

1. Instrument Panel **AIRBAG**

A: REMOVAL

Airbag system wiring harness is routed near combination meter.

CAUTION:

- All airbag system wiring harness and connectors are yellow. Do not use electrical test equipment on these circuits.
- Be careful not to damage airbag system wiring harness when servicing the instrument panel.

- 1) Disconnect ground cable from battery.
- 2) Remove shift knob. (MT model)
- 3) Remove console cover (A) and front cover (B).

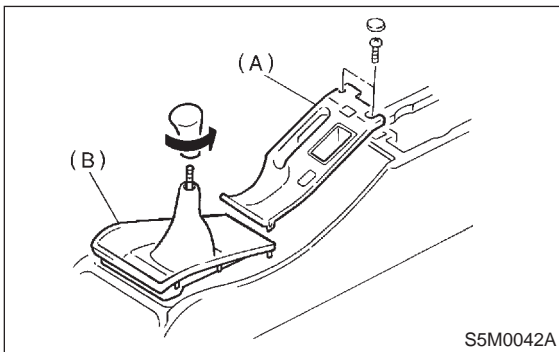

- 4) Remove console box.

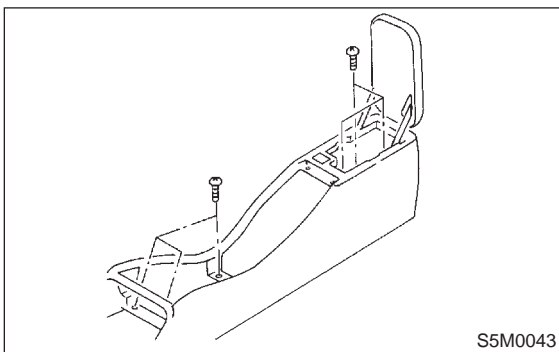

- 5) Remove lower cover and then disconnect connector.

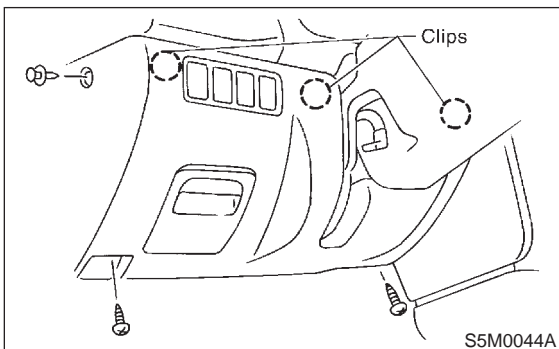

- 6) Disconnect data link connector (A) from lower cover.

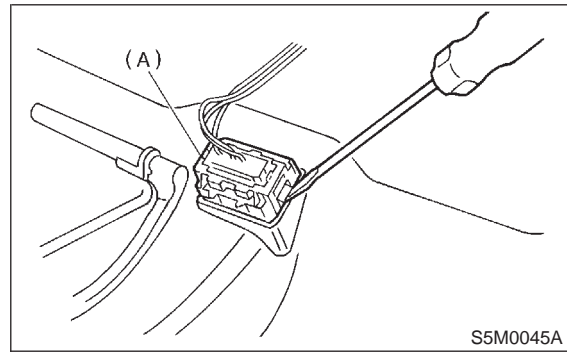

- 7) Remove knee panel.

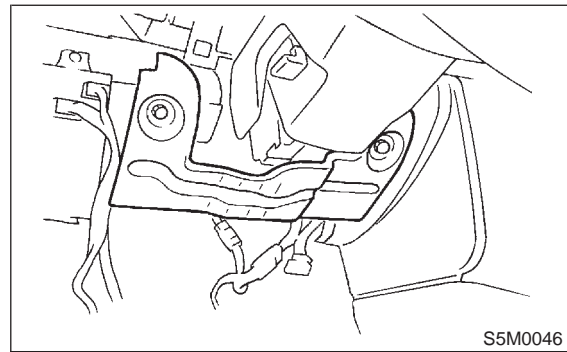

- 8) Remove glove box.

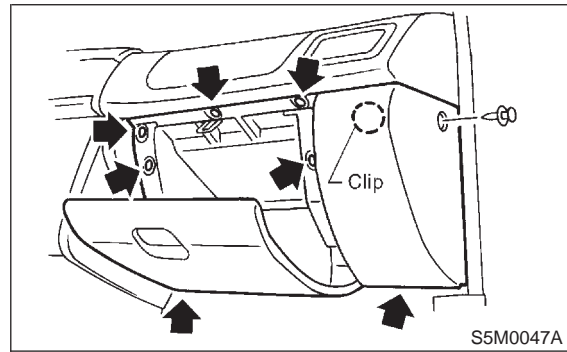

- 9) Remove center panel and disconnect connector.
- 10) Remove audio.

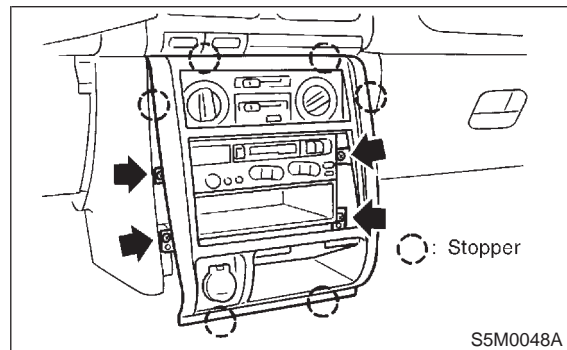

11) Remove the two bolts and lower steering column.

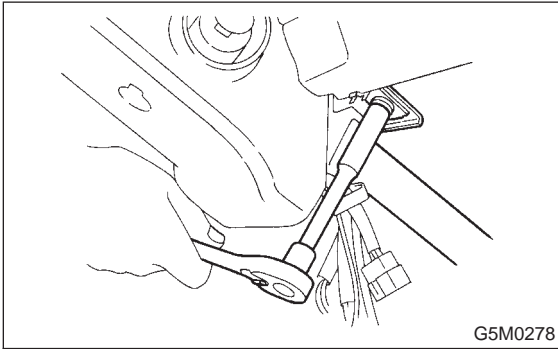

12) Set temperature control switch to "FULL HOT", mode selector switch to "DEF" position and recirc switch to "FRESH" position.

13) Disconnect temperature control cable and mode control cable from heater unit then disconnect recirc control cable from intake unit.

NOTE:

Do not move switch and link when installing.

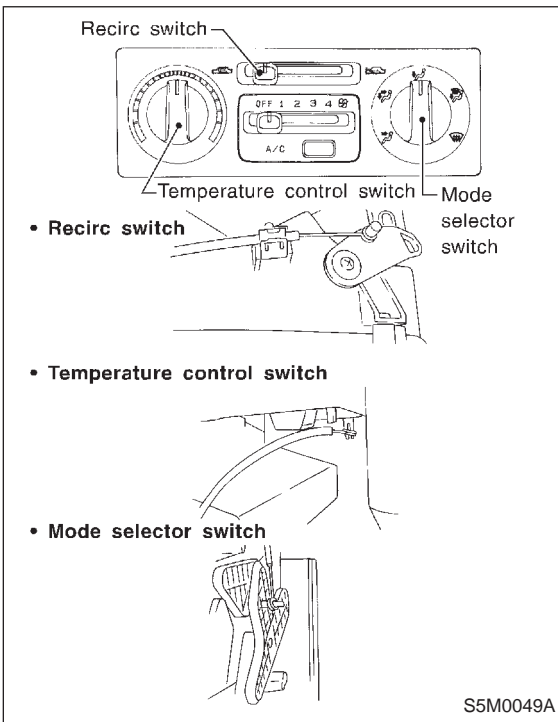

14) Disconnect harness connectors and then remove the installing bolts and nuts.

CAUTION:

Be sure to hold socket section and not harness when disconnecting.

NOTE:

Put matching mark, if necessary, for easy reassembly.

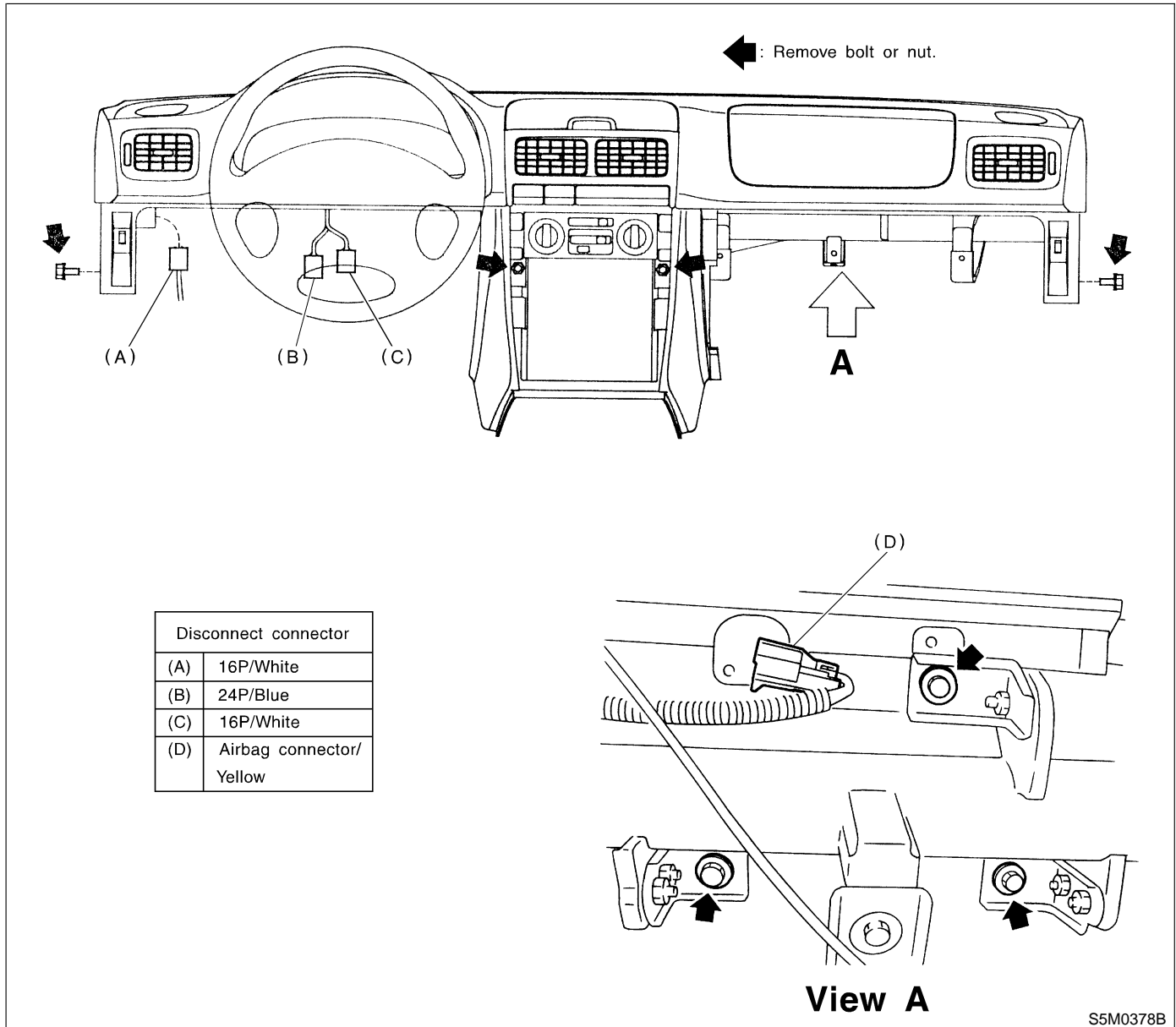

15) Remove front defroster grille and the two bolts.

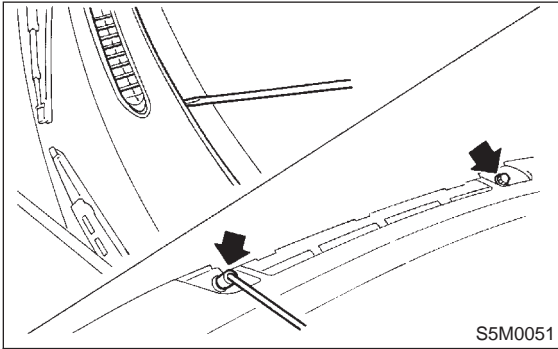

16) Remove instrument panel carefully from the body.

CAUTION:

- Take care not to scratch the instrument panel and related parts.
- When storing removed instrument panel with passenger airbag module, place it standing up on the floor.

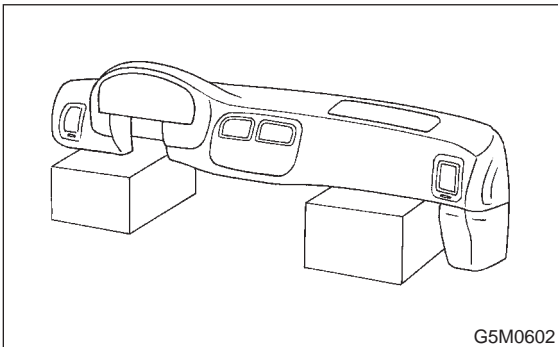
**B: INSTALLATION**

Install in the reverse order of removal.

CAUTION:

- Be careful not to snag the harness.
- Make sure to connect harness connectors.
- Take care not to scratch the instrument panel and related parts.

NOTE:

When setting instrument panel into position, push two pins (A) into grommet (B) on body panel.

