

2) Remove nut which holds fan itself onto fan motor and shroud assembly.

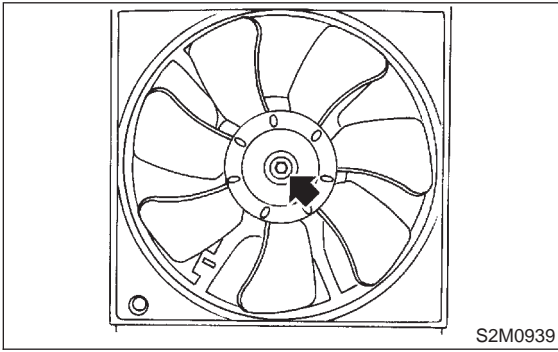

3) Remove bolts which install fan motor onto shroud.

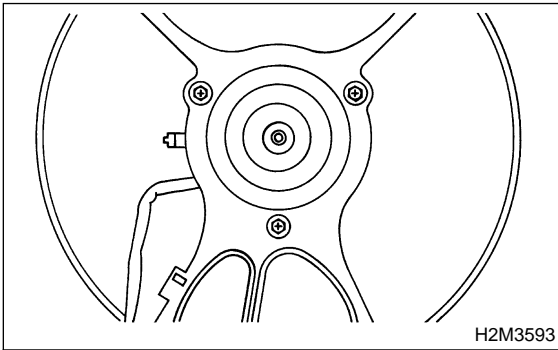

4) Install in the reverse order of removal.

Tightening torque:

$4.4 \pm 0.5 \text{ N}\cdot\text{m}$ ($0.45 \pm 0.05 \text{ kg}\cdot\text{m}$, $3.3 \pm 0.4 \text{ ft}\cdot\text{lb}$)

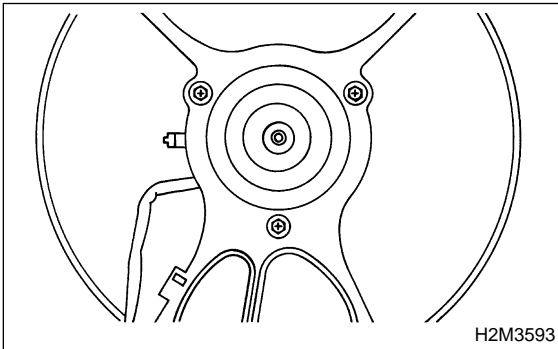

Tightening torque:

$3.4 \pm 0.5 \text{ N}\cdot\text{m}$ ($0.35 \pm 0.05 \text{ kg}\cdot\text{m}$, $2.5 \pm 0.4 \text{ ft}\cdot\text{lb}$)

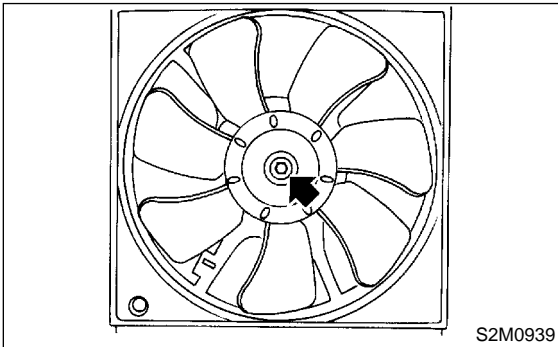

7. Water Pipe

A: REMOVAL

WARNING:

The radiator is pressurized. Wait until engine cools down before working on the radiator.

- 1) Set the vehicle on the lift.
- 2) Release fuel pressure.
<Ref. to 2-8 [W1A0].>
- 3) Disconnect ground cable from the battery.

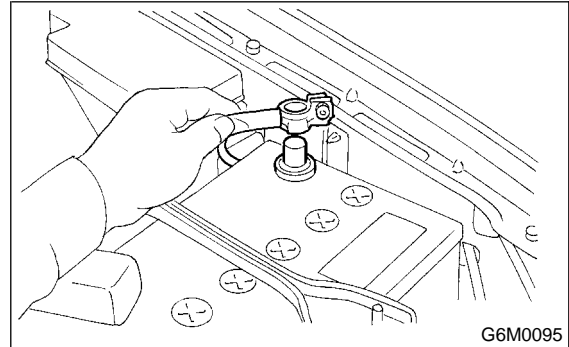

- 4) Drain engine coolant completely.
<Ref. to 2-5 [W9A0].>

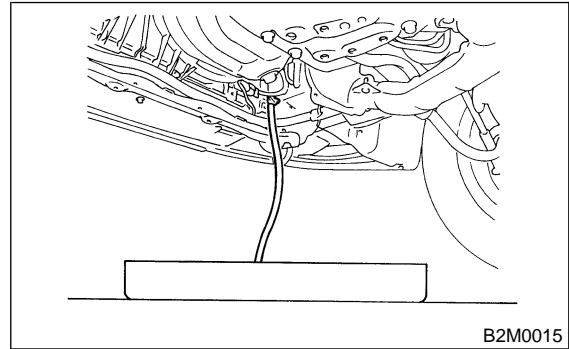

- 5) Lower the vehicle.
- 6) Remove intake manifold.
<Ref. to 2-7 [W3A0].>

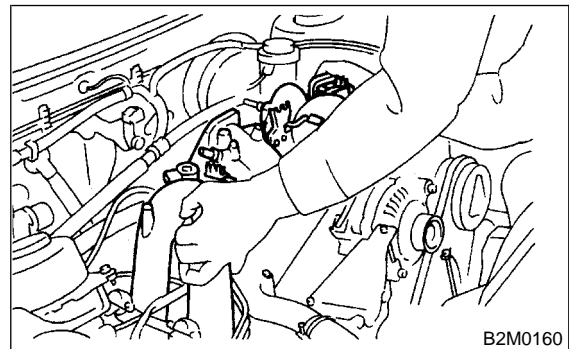

7) Disconnect heater inlet hose.

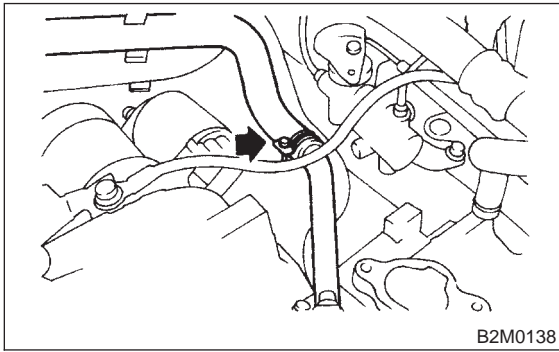

8) Disconnect radiator inlet hose from water pipe.

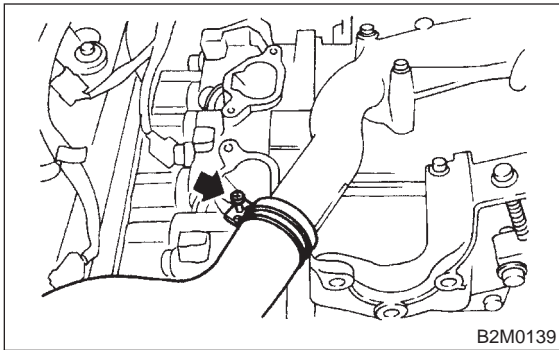

9) Remove bolts which install water pipe on cylinder block.

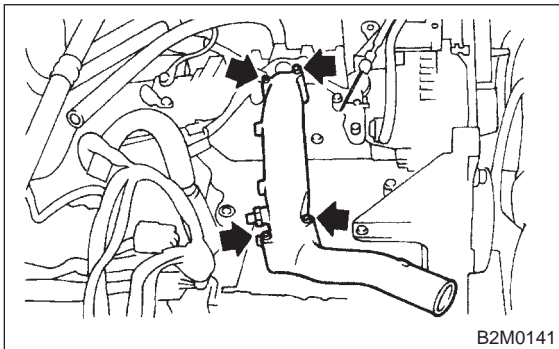

B: INSTALLATION

1) Install water pipe on cylinder block.

Tightening torque:

$6.4 \pm 0.5 \text{ N}\cdot\text{m}$ ($0.65 \pm 0.05 \text{ kg}\cdot\text{m}$, $4.7 \pm 0.4 \text{ ft}\cdot\text{lb}$)

CAUTION:

Use a new O-ring.

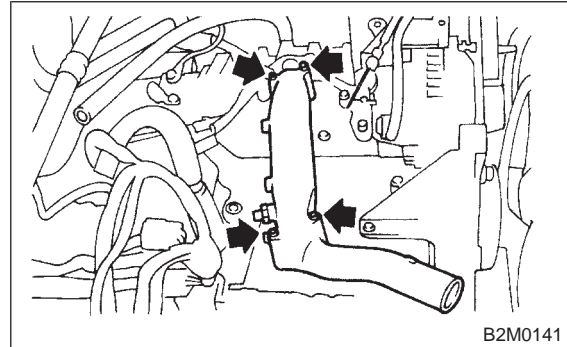

2) Connect radiator inlet hose.

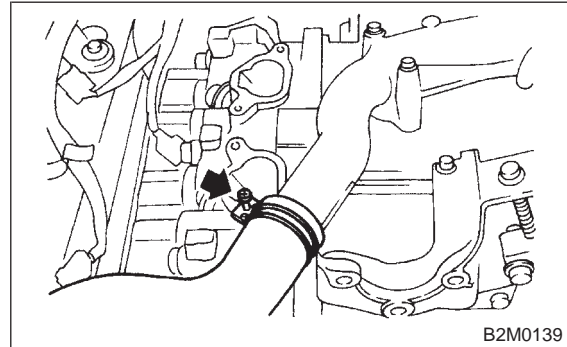

3) Connect heater inlet hose.

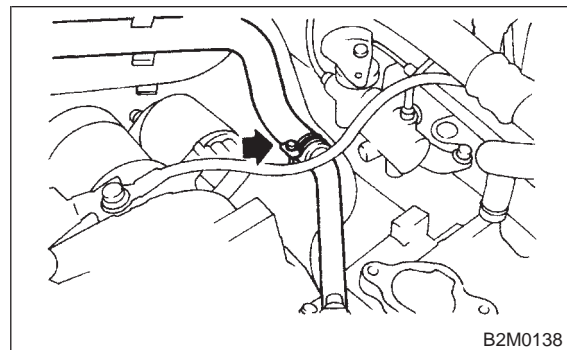

- 4) Install intake manifold.
<Ref. to 2-7 [W3D0].>

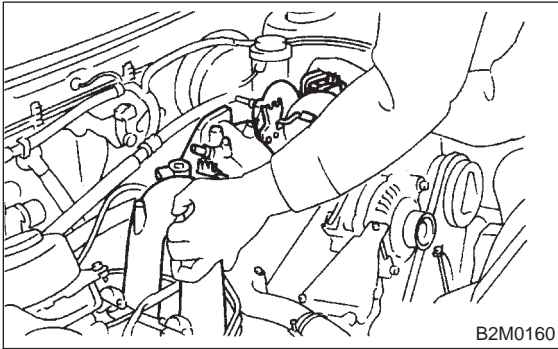

- 5) Connect connector to fuel pump relay.

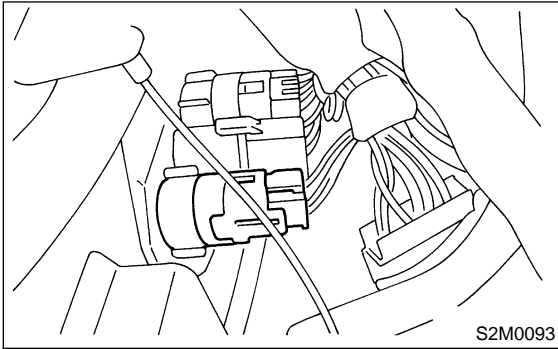

- 6) Connect ground cable to battery.

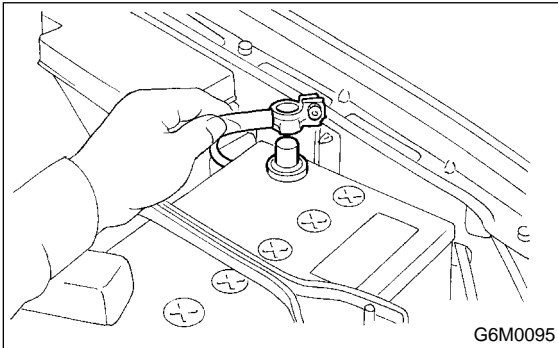

- 7) Lift-up the vehicle.
8) Install under cover.
9) Lower the vehicle.
10) Fill coolant.
<Ref. to 2-5 [W9B0].>

8. Reservoir Tank

A: REMOVAL AND INSTALLATION

- 1) Disconnect over flow hose from radiator filler neck position.

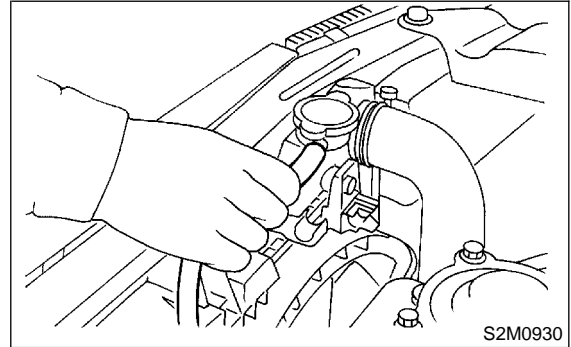

- 2) Remove bolts which install reservoir tank onto radiator main fan shroud.

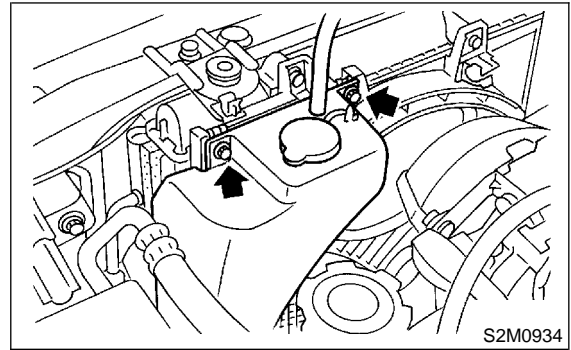

- 3) Remove reservoir tank.

