

1. General Precautions

- 1) All parts should be thoroughly cleaned, paying special attention to the engine oil passages, pistons and bearings.
- 2) Rotating parts and sliding parts such as piston, bearing and gear should be coated with oil prior to assembly.
- 3) Be careful not to let oil, grease or coolant contact the timing belt, clutch disc and flywheel.
- 4) All removed parts, if to be reused, should be reinstalled in the original positions and directions.
- 5) Bolts, nuts and washers should be replaced with new ones as required.
- 6) Even if necessary inspections have been made in advance, proceed with assembly work while making rechecks.

2. General Procedure

- 1) For the procedure of removing the engine from the vehicle, refer to 2-11 ENGINE AND TRANSMISSION MOUNTING SYSTEM. <Ref. to 2-11 [W2A0].> However, before going into the procedure, it is necessary to do the following.

- Before disassembling engine, place it on ST3.
- | | | |
|-----|-----------|----------------------------|
| ST1 | 498457000 | ENGINE STAND ADAPTER
RH |
| ST2 | 498457100 | ENGINE STAND ADAPTER
LH |
| ST3 | 499817000 | ENGINE STAND |

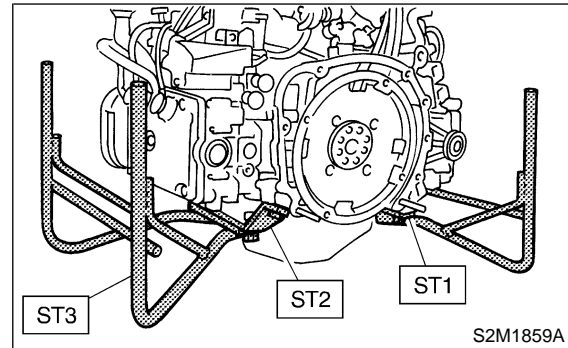

- 2) It is possible to conduct the following service procedures with engine on the vehicle, however, the procedures described in this section are based on the condition that the engine is removed from the vehicle.

- Timing Belt
- Valve Rocker Assembly
- Camshaft
- Cylinder Head

- 3) In this section the procedures described under each index are all connected and stated in order. It will be the complete procedure for over hauling of the engine it-self when you go through all steps in the process.

Therefore, in this section, to conduct the particular procedure within the flow of a section, you need to go back and conduct the procedure described previously in order to do that particular procedure.