

1. Front and Center Exhaust Pipe Assembly

A: REMOVAL

- 1) Set the vehicle on the lift.
- 2) Disconnect battery ground cable.

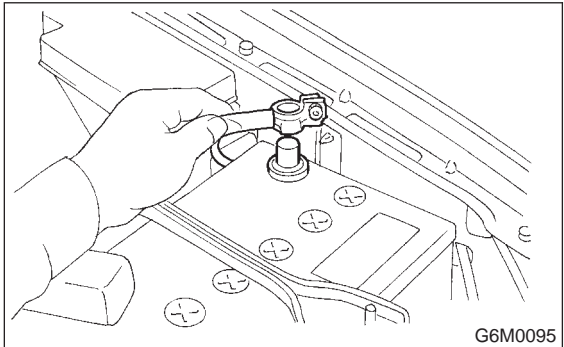

- 3) Disconnect front oxygen (A/F) sensor connector.

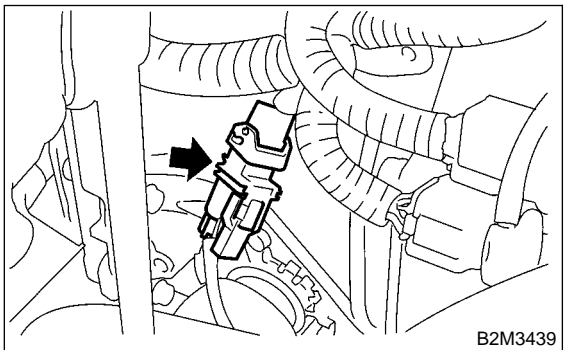

- 4) Lift-up the vehicle.
- 5) Remove under cover.
- 6) Disconnect rear oxygen sensor connector.

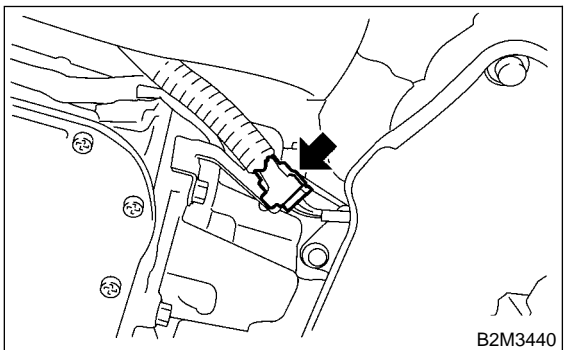

- 7) Separate front and center exhaust pipe assembly from rear exhaust pipe.

WARNING:

Be careful, exhaust pipe is hot.

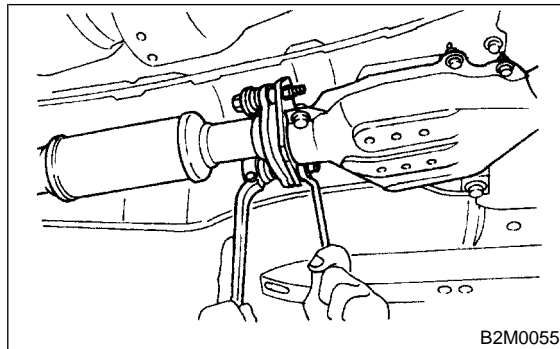

- 8) Remove bolts which hold front exhaust pipe onto cylinder heads.

CAUTION:

Be careful not to pull down front and center exhaust pipe assembly.

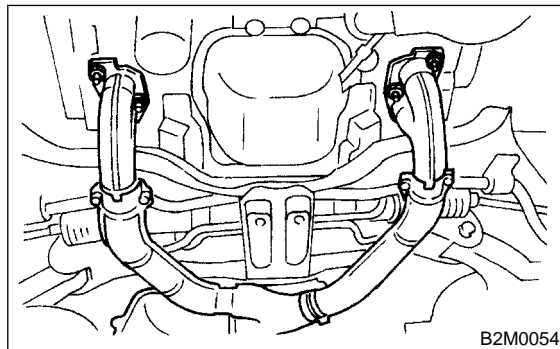

- 9) Remove bolt which installs front and center exhaust pipe assembly to hanger bracket.

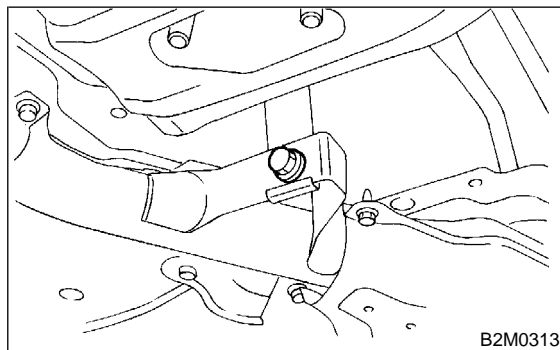

- 10) Remove front and center exhaust pipe assembly from the vehicle.

CAUTION:

- Be careful not to let front and center exhaust pipe assembly fall off when removing as it is quite heavy.
- After removing front and center exhaust assembly, do not apply excessive pulling force on rear exhaust pipe.

1. Front and Center Exhaust Pipe Assembly

11) Separate front exhaust pipe from front catalytic converter and center exhaust pipe assembly.

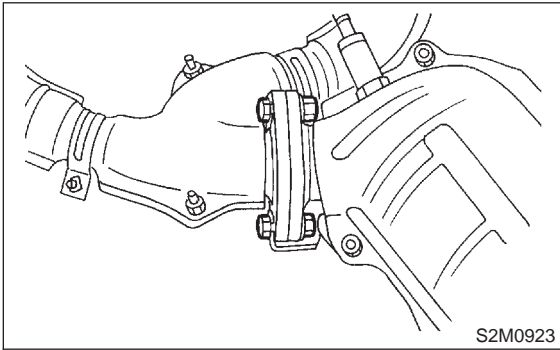
**B: INSTALLATION**

1) Install front exhaust pipe to front catalytic converter and center exhaust pipe assembly.

CAUTION:

Replace gaskets with new ones.

Tightening torque:

30 ± 5 N·m (3.1 ± 0.5 kg·m, 22.4 ± 3.6 ft·lb)

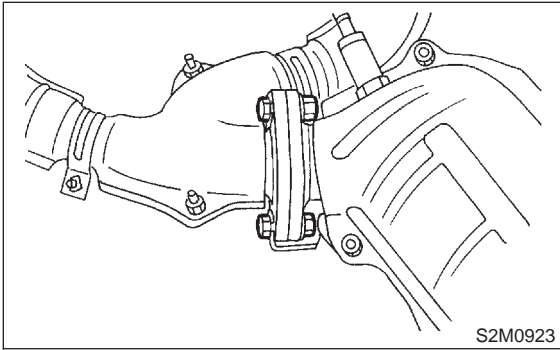

2) Install front and center exhaust pipe assembly to the vehicle.

3) Temporarily tighten bolt which installs front and center exhaust pipe assembly to hanger bracket.

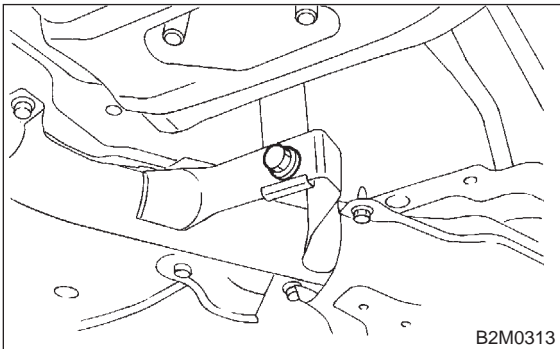

4) Tighten bolts which hold front exhaust pipe onto cylinder heads.

Tightening torque:

30 ± 5 N·m (3.1 ± 0.5 kg·m, 22.4 ± 3.6 ft·lb)

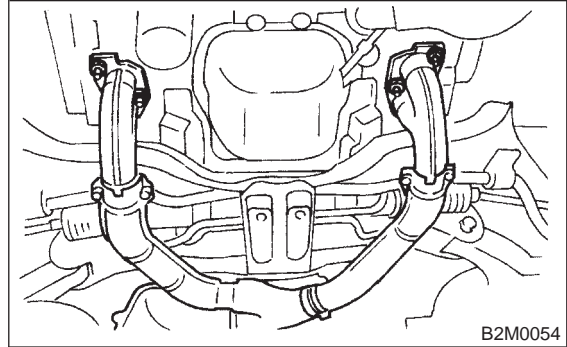

5) Tighten bolts which install front and center exhaust pipe assembly to rear exhaust pipe.

Tightening torque:

18 ± 5 N·m (1.8 ± 0.5 kg·m, 13.0 ± 3.6 ft·lb)

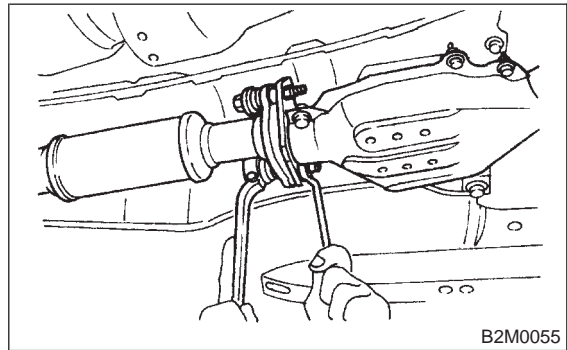

6) Tighten bolt which holds front and center exhaust pipe assembly to hanger bracket.

Tightening torque:

35 ± 5 N·m (3.6 ± 0.5 kg·m, 26.0 ± 3.6 ft·lb)

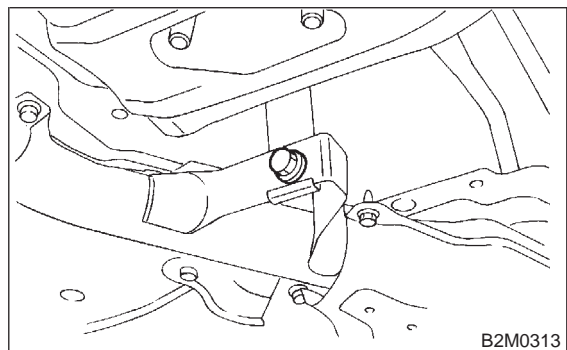

7) Connect rear oxygen sensor connector.

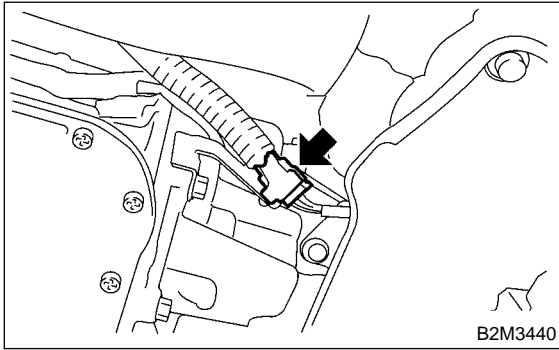

- 8) Install under cover.
- 9) Lower the vehicle.
- 10) Connect front oxygen (A/F) sensor connector.

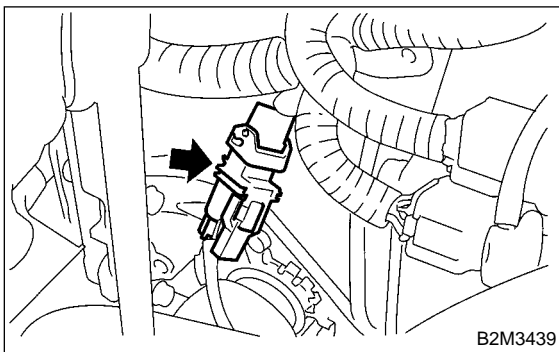

11) Connect battery ground cable.

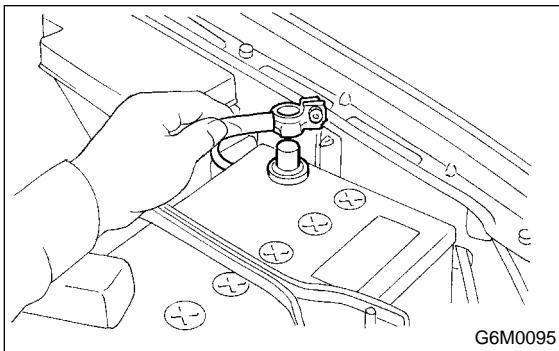

2. Rear Exhaust Pipe

A: REMOVAL

- 1) Lift-up the vehicle.
- 2) Separate rear exhaust pipe from center exhaust pipe.

WARNING:
Be careful, exhaust pipe is hot.

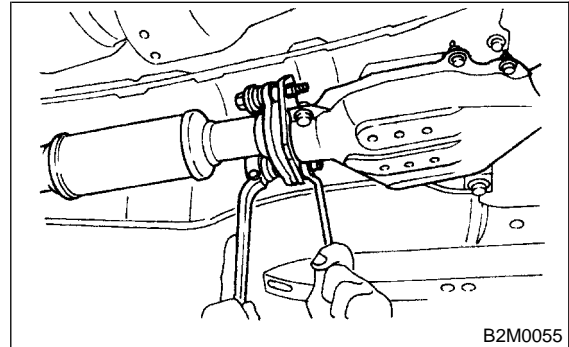

- 3) Separate rear exhaust pipe from muffler.

CAUTION:
Be careful not to pull down rear exhaust pipe.

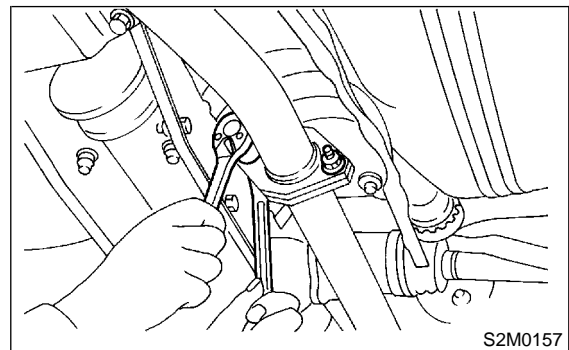

- 4) Remove rear exhaust pipe bracket from rubber cushion.

NOTE:
To facilitate removal, apply a coat of SUBARU CRC or equivalent to pipe bracket in advance.

SUBARU CRC (Part No. 004301003)

