

7) Connect rear oxygen sensor connector.

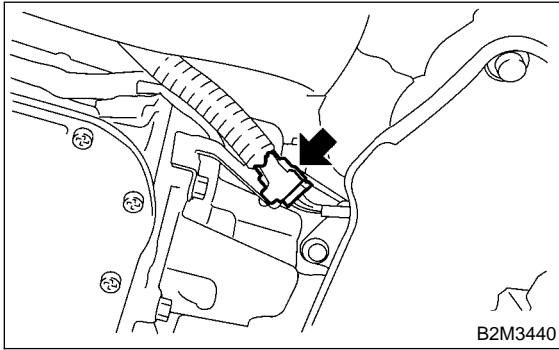

- 8) Install under cover.
- 9) Lower the vehicle.
- 10) Connect front oxygen (A/F) sensor connector.

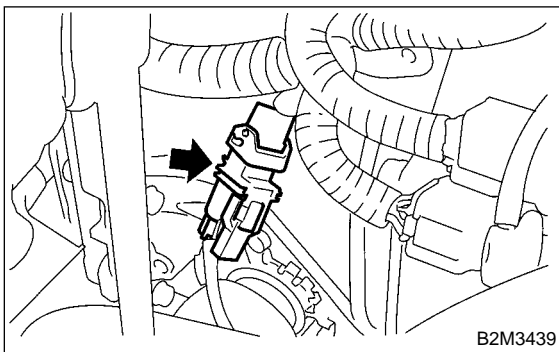

11) Connect battery ground cable.

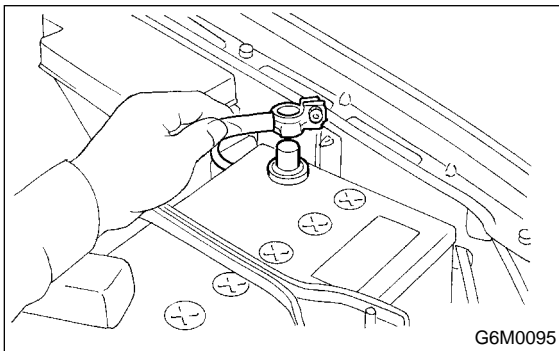

2. Rear Exhaust Pipe

A: REMOVAL

- 1) Lift-up the vehicle.
- 2) Separate rear exhaust pipe from center exhaust pipe.

WARNING:
Be careful, exhaust pipe is hot.

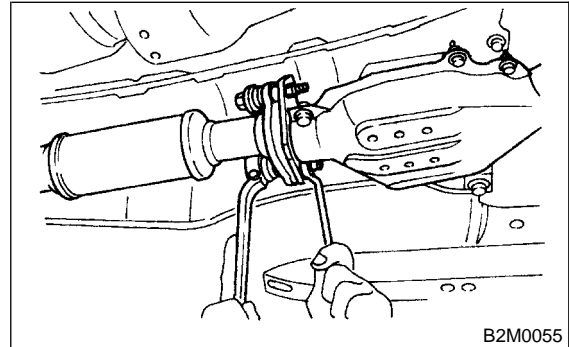

- 3) Separate rear exhaust pipe from muffler.

CAUTION:
Be careful not to pull down rear exhaust pipe.

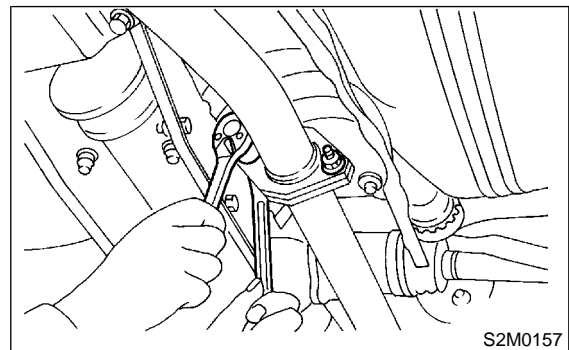

- 4) Remove rear exhaust pipe bracket from rubber cushion.

NOTE:
To facilitate removal, apply a coat of SUBARU CRC or equivalent to pipe bracket in advance.

SUBARU CRC (Part No. 004301003)

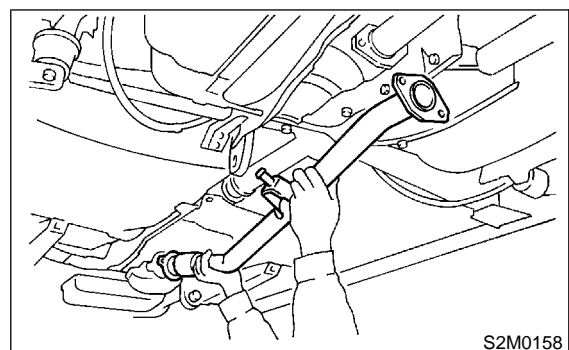

B: INSTALLATION**CAUTION:**

Replace gaskets with new ones.

- 1) Install rear exhaust pipe bracket to rubber cushion.

NOTE:

To facilitate installation, apply a coat of SUBARU CRC or equivalent to mating area of rubber cushion in advance.

SUBARU CRC (Part No. 004301003)

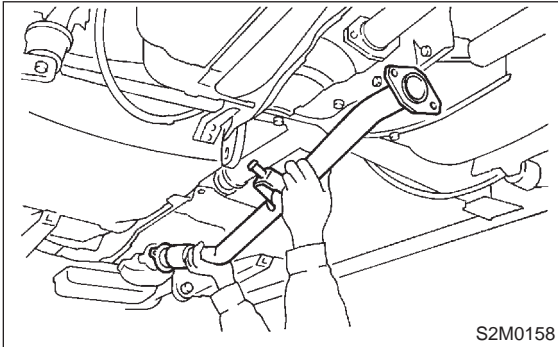

- 2) Install rear exhaust pipe to muffler.

Tightening torque:

$48 \pm 5 \text{ N}\cdot\text{m}$ ($4.9 \pm 0.5 \text{ kg}\cdot\text{m}$, $35.4 \pm 3.6 \text{ ft}\cdot\text{lb}$)

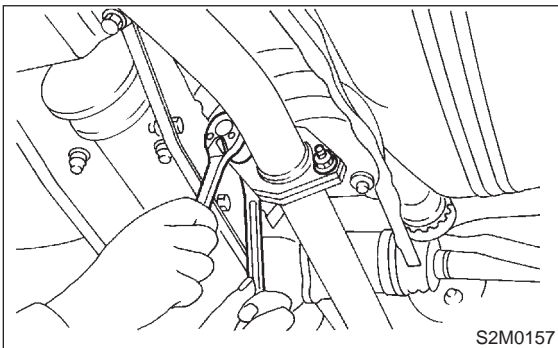

- 3) Install rear exhaust pipe to center exhaust pipe.

Tightening torque:

$18 \pm 5 \text{ N}\cdot\text{m}$ ($1.8 \pm 0.5 \text{ kg}\cdot\text{m}$, $13.0 \pm 3.6 \text{ ft}\cdot\text{lb}$)

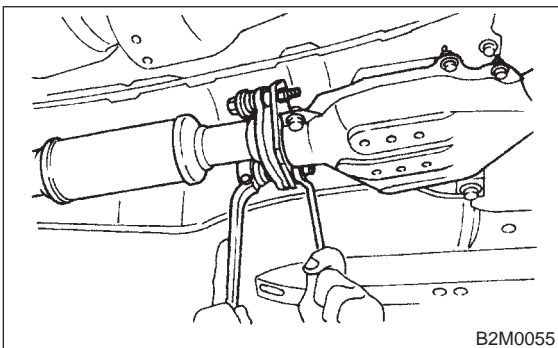
**3. Muffler****A: REMOVAL AND INSTALLATION****WARNING:**

Be careful, exhaust pipe is hot.

- 1) Lift-up the vehicle.
- 2) Separate muffler from rear exhaust pipe.

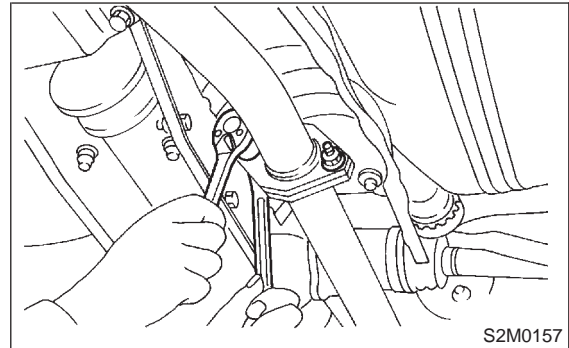

- 3) Remove left and right rubber cushions.

CAUTION:

Be careful not to pull down muffler.

NOTE:

To facilitate removal, apply a coat of SUBARU CRC or equivalent to mating area of rubber cushions in advance.

SUBARU CRC (Part No. 004301003)

