

8. Valve Clearance

A: INSPECTION

CAUTION:

Inspection and adjustment of valve clearance should be performed while engine is cold.

- 1) Set the vehicle onto the lift.
- 2) Disconnect battery ground cable.

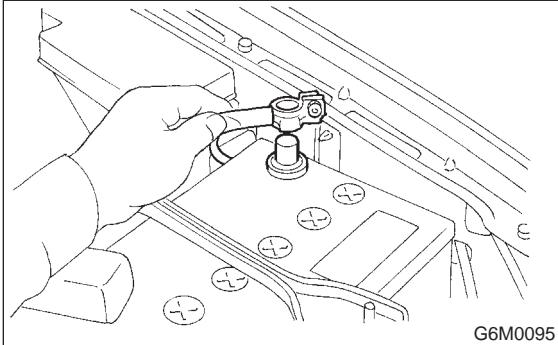

- 3) Remove engine coolant reservoir tank.
<Ref. to 2-5 [W8A0].>

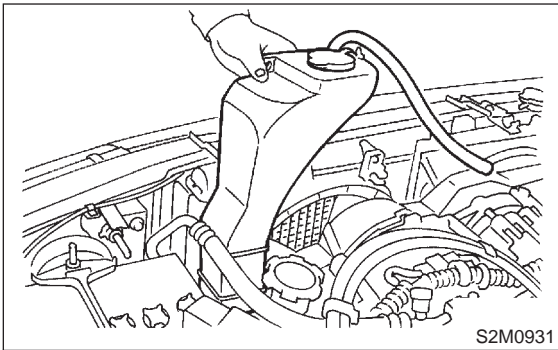

- 4) Remove timing belt cover (LH).

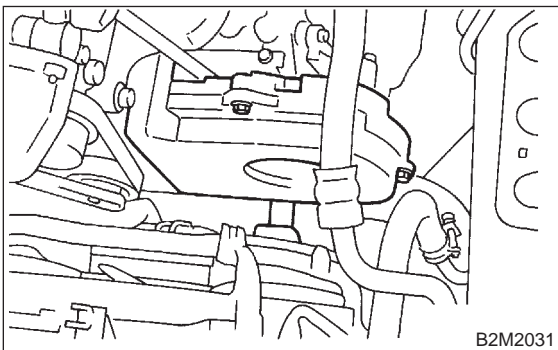

- 5) Remove rocker cover.
- 6) When inspecting #1 and #3 cylinders:
 - (1) Remove air intake duct as a unit.

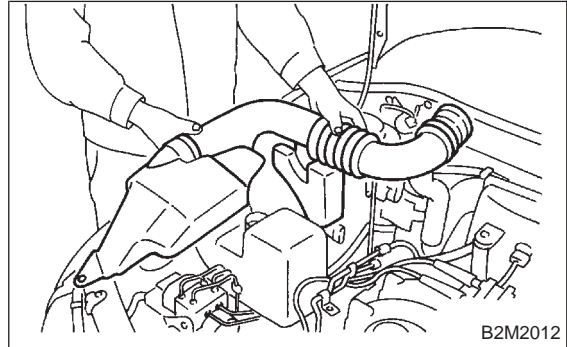

- (2) Remove resonator chamber.

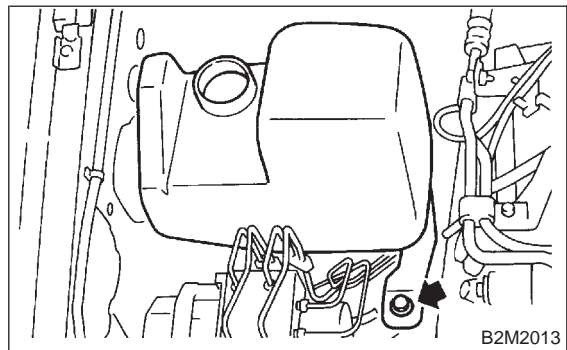

- (3) Disconnect spark plug cords from spark plugs (#1 and #3 cylinders).

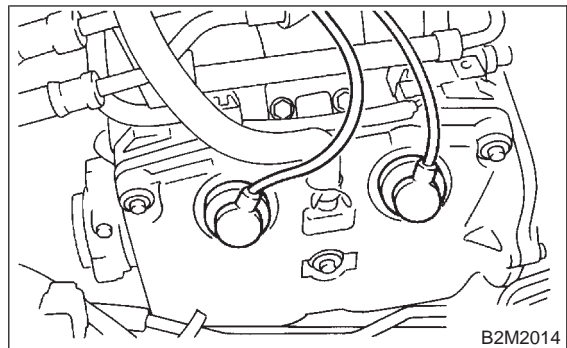

- (4) Disconnect blow-by hose from rocker cover (RH).

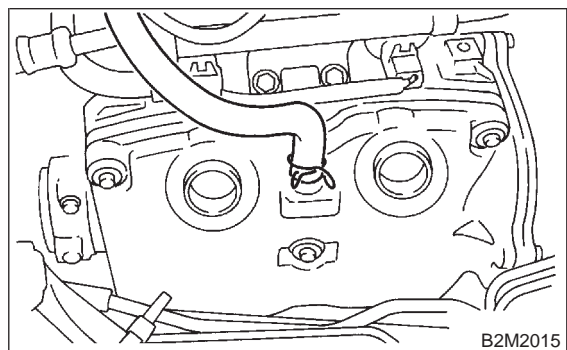

- (5) Lift-up the vehicle.
- (6) Remove under cover.

- (7) Place suitable container under the vehicle.
- (8) Lower the vehicle.
- (9) Remove the timing belt cover (RH) bolt.

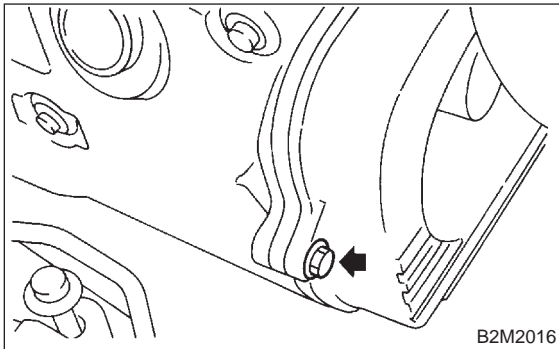

- (10) Remove rocker cover bolts, then remove rocker cover (RH).

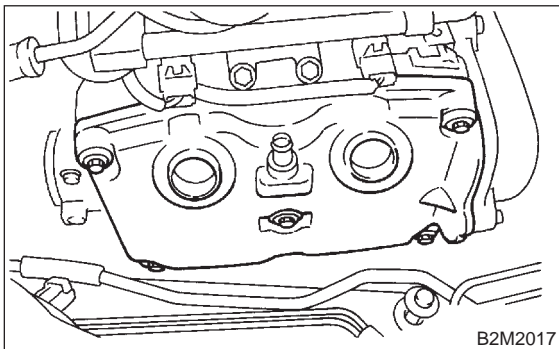

- 7) When inspecting #2 and #4 cylinders:
 - (1) Disconnect battery cables, and then remove battery and battery carrier.
 - (2) Disconnect front window washer motor connector.
 - (3) Disconnect rear gate glass washer motor connector.

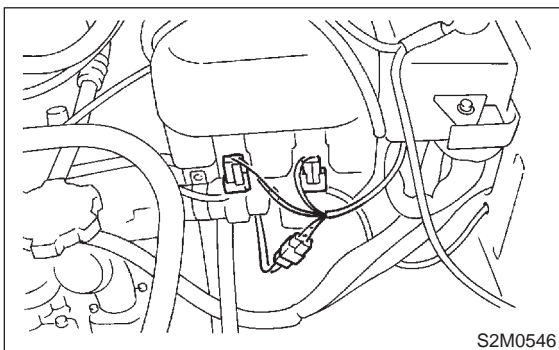

- (4) Disconnect rear gate glass washer hose from washer motor, then plug connection with a suitable cap.

- (5) Remove the two bolts which hold washer tank, then secure the tank away from working area.

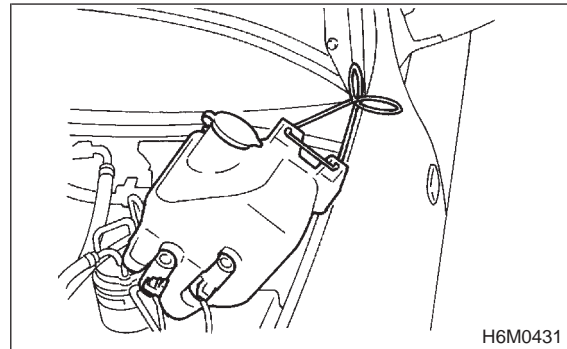

- (6) Disconnect spark plug cords from spark plugs (#2 and #4 cylinders).

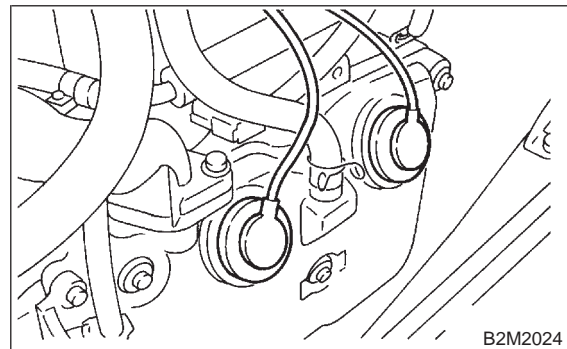

- (7) Disconnect blow-by hose form rocker cover.

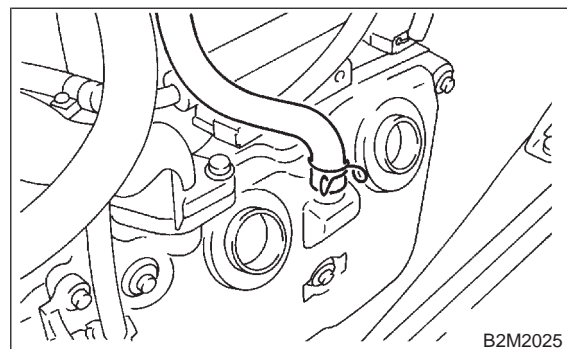

- (8) Lift-up the vehicle.
- (9) Remove under cover.
- (10) Place suitable container under the vehicle.

(11) Remove rocker cover bolts, then remove rocker cover (LH).

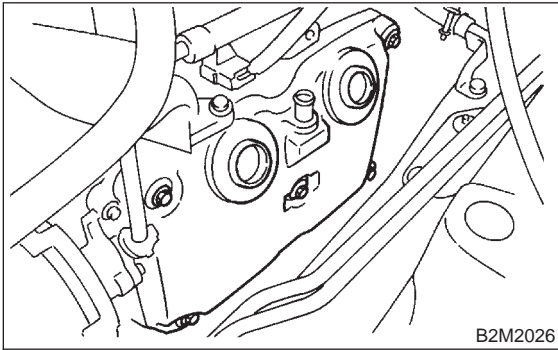

8) Set #1 cylinder piston to top dead center of compression stroke by rotating crankshaft pulley clockwise.

NOTE:

When arrow mark (A) on camshaft sprocket (LH) comes exactly to the top, #1 cylinder piston is brought to the top dead center of the compression stroke.

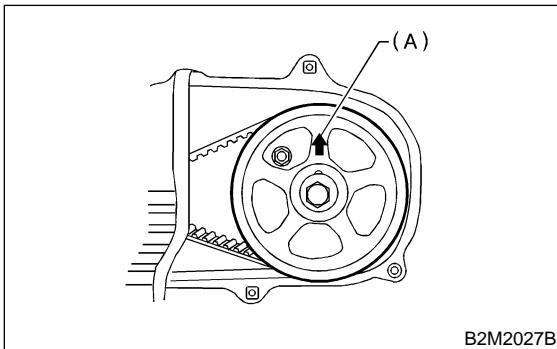

9) Measure #1 cylinder valve clearance by using thickness gauge (A).

CAUTION:

- Insert the thickness gauge (A) in at as horizontal a direction as a possible with respect to the valve stem end face.
- Measure exhaust valve clearances while lifting-up the vehicle.

Valve clearance:

Intake: 0.20 ± 0.02 mm (0.0079 ± 0.0008 in)

Exhaust: 0.25 ± 0.02 mm (0.0098 ± 0.0008 in)

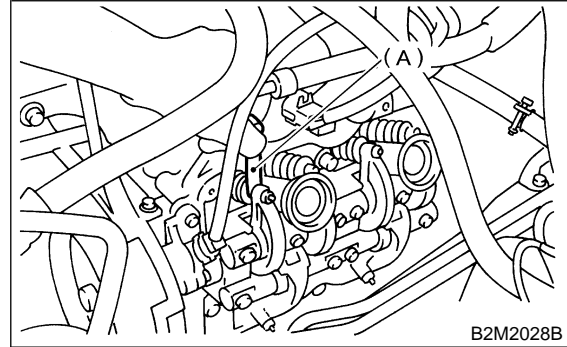

10) If necessary, adjust the valve clearance. <Ref. to 2-2 [W7B0].>

11) Similar to measurement procedures used for #1 cylinder, measure #2, #3 and #4 cylinder valve clearances.

NOTE:

- Be sure to set cylinder pistons to their respective top dead centers on the compression stroke before measuring valve clearances.
- To set #3, #2 and #4 cylinder pistons to their top dead centers on the compression stroke, turn crankshaft pulley clockwise 90° at a time starting with arrow mark on left-hand camshaft sprocket facing up.

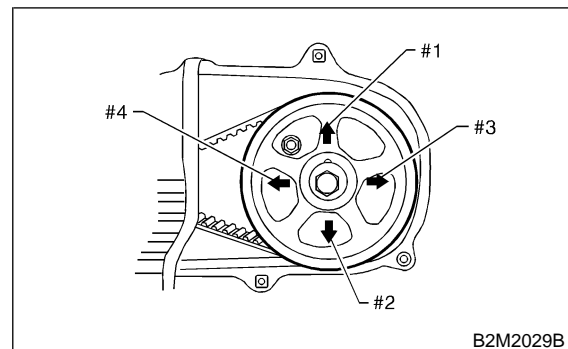

12) After inspection, install the related parts in the reverse order of removal.

Tightening torque:

$33 \pm 10 \text{ N}\cdot\text{m}$ ($3.4 \pm 1.0 \text{ kg}\cdot\text{m}$, $25 \pm 7 \text{ ft}\cdot\text{lb}$)

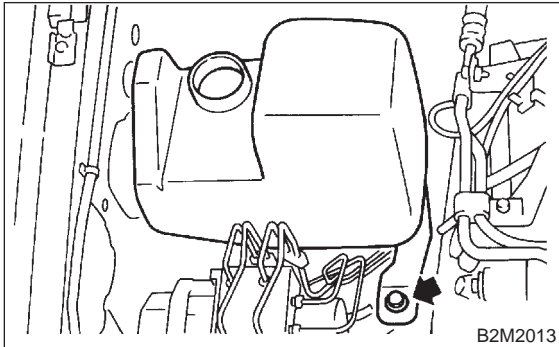

B: ADJUSTMENT

CAUTION:

Adjustment of valve clearance should be performed while engine is cold.

1) Set #1 cylinder piston to top dead center of compression stroke by rotating crankshaft pulley clockwise.

NOTE:

When arrow mark (A) on camshaft sprocket (LH) comes exactly to the top, #1 cylinder piston is brought to the top dead center of the compression stroke.

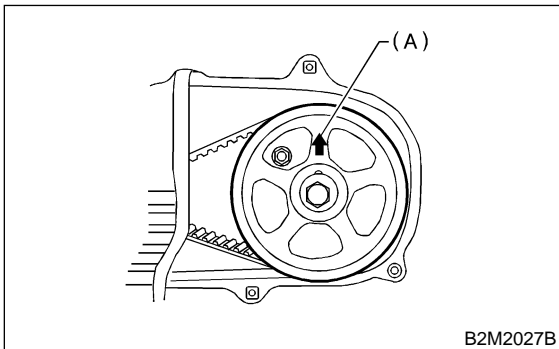

2) Adjust the #1 cylinder valve clearance.

- (1) Loosen the valve rocker nut and screw.
- (2) Place suitable thickness gauge.
- (3) While noting valve clearance, tighten valve rocker adjust screw.
- (4) When specified valve clearance is obtained, tighten valve rocker nut.

Tightening torque:

$10 \pm 1 \text{ N}\cdot\text{m}$ ($1.0 \pm 0.1 \text{ kg}\cdot\text{m}$, $7.2 \pm 0.7 \text{ ft}\cdot\text{lb}$)

CAUTION:

- Insert the thickness gauge in at as horizontal a direction as possible with respect to the valve stem end face.
- Adjust exhaust valve clearances while lifting-up the vehicle.

Valve clearance:

Intake: $0.20 \pm 0.02 \text{ mm}$ ($0.0079 \pm 0.0008 \text{ in}$)

Exhaust: $0.25 \pm 0.02 \text{ mm}$ ($0.0098 \pm 0.0008 \text{ in}$)

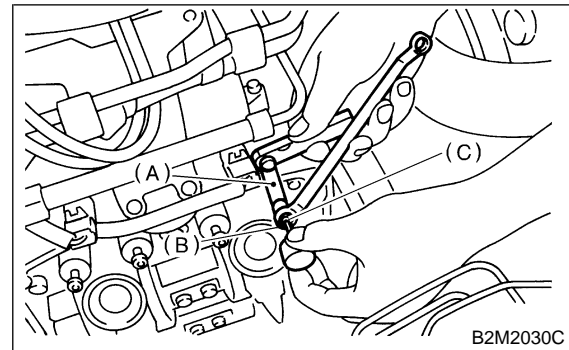

- (A) Thickness gauge
- (B) Valve rocker nut
- (C) Valve rocker screw

3) Ensure that valve clearances are within specifications.

4) Turn crankshaft two complete rotations until #1 cylinder piston is again set to top dead center on compression stroke.

5) Ensure that valve clearances are within specifications. If necessary, re-adjust valve clearances.

8. Valve Clearance

6) Similar to adjustment procedures used for #1 cylinder, adjust #2, #3 and #4 cylinder valve clearances.

NOTE:

- Be sure to set cylinder pistons to their respective top dead centers on the compression stroke before adjusting valve clearances.
- To set #3, #2 and #4 cylinder pistons to their top dead centers on the compression stroke, turn crankshaft pulley clockwise 90° at a time starting with arrow mark on left-hand camshaft sprocket facing up.

