

## 10. Diagnostics Chart with Trouble Code

### A: DIAGNOSTIC TROUBLE CODE (DTC) LIST

DTC No.	Item	Index
P0106	Pressure sensor circuit range/performance problem	<Ref. to 2-7 [T10B0].>
P0107	Pressure sensor circuit low input	<Ref. to 2-7 [T10C0].>
P0108	Pressure sensor circuit high input	<Ref. to 2-7 [T10D0].>
P0111	Intake air temperature sensor circuit range/performance problem	<Ref. to 2-7 [T10E0].>
P0112	Intake air temperature sensor circuit low input	<Ref. to 2-7 [T10F0].>
P0113	Intake air temperature sensor circuit high input	<Ref. to 2-7 [T10G0].>
P0116	Engine coolant temperature sensor circuit low input	<Ref. to 2-7 [T10H0].>
P0117	Engine coolant temperature sensor circuit high input	<Ref. to 2-7 [T10I0].>
P0121	Throttle position sensor circuit range/performance problem (high input)	<Ref. to 2-7 [T10J0].>
P0122	Throttle position sensor circuit low input	<Ref. to 2-7 [T10K0].>
P0123	Throttle position sensor circuit high input	<Ref. to 2-7 [T10L0].>
P0125	Insufficient coolant temperature for closed loop fuel control	<Ref. to 2-7 [T10M0].>
P0130	Front oxygen (A/F) sensor circuit range/performance problem	<Ref. to 2-7 [T10N0].>
P0133	Front oxygen (A/F) sensor circuit slow response	<Ref. to 2-7 [T10O0].>
P0136	Rear oxygen sensor circuit malfunction	<Ref. to 2-7 [T10P0].>
P0139	Rear oxygen sensor circuit slow response	<Ref. to 2-7 [T10Q0].>
P0141	Rear oxygen sensor heater circuit malfunction	<Ref. to 2-7 [T10R0].>
P0170	Fuel trim malfunction	<Ref. to 2-7 [T10S0].>
P0181	Fuel temperature sensor A circuit range/performance problem	<Ref. to 2-7 [T10T0].>
P0182	Fuel temperature sensor A circuit low input	<Ref. to 2-7 [T10U0].>
P0183	Fuel temperature sensor A circuit high input	<Ref. to 2-7 [T10V0].>
P0301	Cylinder 1 misfire detected	<Ref. to 2-7 [T10W0].>
P0302	Cylinder 2 misfire detected	<Ref. to 2-7 [T10X0].>
P0303	Cylinder 3 misfire detected	<Ref. to 2-7 [T10Y0].>
P0304	Cylinder 4 misfire detected	<Ref. to 2-7 [T10Z0].>

DTC No.	Item	Index
P0325	Knock sensor circuit high input	<Ref. to 2-7 [T10AA0].>
P0335	Crankshaft position sensor circuit malfunction	<Ref. to 2-7 [T10AB0].>
P0336	Crankshaft position sensor circuit range/performance problem	<Ref. to 2-7 [T10AC0].>
P0340	Camshaft position sensor circuit malfunction	<Ref. to 2-7 [T10AD0].>
P0341	Camshaft position sensor circuit range/performance problem	<Ref. to 2-7 [T10AE0].>
P0420	Catalyst system efficiency below threshold	<Ref. to 2-7 [T10AF0].>
P0440	Evaporative emission control system malfunction	<Ref. to 2-7 [T10AG0].>
P0442	Evaporative emission control system malfunction	<Ref. to 2-7 [T10AH0].>
P0443	Evaporative emission control system purge control valve circuit low input	<Ref. to 2-7 [T10AI0].>
P0446	Evaporative emission control system vent control low input	<Ref. to 2-7 [T10AJ0].>
P0451	Evaporative emission control system pressure sensor range/performance problem	<Ref. to 2-7 [T10AK0].>
P0452	Evaporative emission control system pressure sensor low input	<Ref. to 2-7 [T10AL0].>
P0453	Evaporative emission control system pressure sensor high input	<Ref. to 2-7 [T10AM0].>
P0461	Fuel level sensor circuit range/performance problem	<Ref. to 2-7 [T10AN0].>
P0462	Fuel level sensor circuit low input	<Ref. to 2-7 [T10AO0].>
P0463	Fuel level sensor circuit high input	<Ref. to 2-7 [T10AP0].>
P0480	Cooling fan relay 1 circuit low input	<Ref. to 2-7 [T10AQ0].>
P0483	Cooling fan function problem	<Ref. to 2-7 [T10AR0].>
P0500	Vehicle speed sensor malfunction	<Ref. to 2-7 [T10AS0].>
P0506	Idle control system RPM lower than expected	<Ref. to 2-7 [T10AT0].>
P0507	Idle control system RPM higher than expected	<Ref. to 2-7 [T10AU0].>
P0601	Internal control module memory check sum error	<Ref. to 2-7 [T10AV0].>
P0703	Brake switch input malfunction	<Ref. to 2-7 [T10AW0].>
P0705	Transmission range sensor circuit malfunction	<Ref. to 2-7 [T10AX0].>
P0710	Transmission fluid temperature sensor circuit malfunction	<Ref. to 2-7 [T10AY0].>
P0715	Torque converter turbine speed sensor circuit malfunction	<Ref. to 2-7 [T10AZ0].>
P0720	Output speed sensor (vehicle speed sensor 2) circuit malfunction	<Ref. to 2-7 [T10BA0].>

DTC No.	Item	Index
P0725	Engine speed input circuit malfunction	<Ref. to 2-7 [T10BB0].>
P0731	Gear 1 incorrect ratio	<Ref. to 2-7 [T10BC0].>
P0732	Gear 2 incorrect ratio	<Ref. to 2-7 [T10BD0].>
P0733	Gear 3 incorrect ratio	<Ref. to 2-7 [T10BE0].>
P0734	Gear 4 incorrect ratio	<Ref. to 2-7 [T10BF0].>
P0740	Torque converter clutch system malfunction	<Ref. to 2-7 [T10BG0].>
P0743	Torque converter clutch system (Lock-up duty solenoid) electrical	<Ref. to 2-7 [T10BH0].>
P0748	Pressure control solenoid (Line pressure duty solenoid) electrical	<Ref. to 2-7 [T10BI0].>
P0753	Shift solenoid A (Shift solenoid 1) electrical	<Ref. to 2-7 [T10BJ0].>
P0758	Shift solenoid B (Shift solenoid 2) electrical	<Ref. to 2-7 [T10BK0].>
P1100	Starter switch circuit low input	<Ref. to 2-7 [T10BL0].>
P1101	Neutral position switch circuit low input [MT vehicles] or Neutral position switch circuit high input [AT vehicles]	<Ref. to 2-7 [T10BM0].>
P1103	Engine torque control signal 1 circuit malfunction	<Ref. to 2-7 [T10BN0].>
P1106	Engine torque control signal 2 circuit malfunction	<Ref. to 2-7 [T10BO0].>
P1110	Atmospheric pressure sensor circuit low input	<Ref. to 2-7 [T10BP0].>
P1111	Atmospheric pressure sensor circuit high input	<Ref. to 2-7 [T10BQ0].>
P1112	Atmospheric pressure sensor range/performance problem	<Ref. to 2-7 [T10BR0].>
P1115	Engine torque control cut signal circuit high input	<Ref. to 2-7 [T10BS0].>
P1116	Engine torque control cut signal circuit low input	<Ref. to 2-7 [T10BT0].>
P1120	Starter switch circuit high input	<Ref. to 2-7 [T10BU0].>
P1121	Neutral position switch circuit high input [MT vehicles] or Neutral position switch circuit low input [AT vehicles]	<Ref. to 2-7 [T10BV0].>
P1130	Front oxygen (A/F) sensor circuit malfunction (open circuit)	<Ref. to 2-7 [T10BW0].>
P1131	Front oxygen (A/F) sensor circuit malfunction (short circuit)	<Ref. to 2-7 [T10BX0].>
P1132	Front oxygen (A/F) sensor heater circuit low input	<Ref. to 2-7 [T10BY0].>
P1133	Front oxygen (A/F) sensor heater circuit high input	<Ref. to 2-7 [T10BZ0].>
P1142	Throttle position sensor circuit range/performance problem (low input)	<Ref. to 2-7 [T10CA0].>
P1151	Rear oxygen sensor heater circuit high input	<Ref. to 2-7 [T10CB0].>

DTC No.	Item	Index
P1207	Air assist injector solenoid valve circuit low input	<Ref. to 2-7 [T10CC0].>
P1208	Air assist injector solenoid valve circuit high input	<Ref. to 2-7 [T10CD0].>
P1325	Knock sensor circuit low input	<Ref. to 2-7 [T10CE0].>
P1400	Fuel tank pressure control solenoid valve circuit low input	<Ref. to 2-7 [T10CF0].>
P1420	Fuel tank pressure control solenoid valve circuit high input	<Ref. to 2-7 [T10CG0].>
P1422	Evaporative emission control system purge control valve circuit high input	<Ref. to 2-7 [T10CH0].>
P1423	Evaporative emission control system vent control high input	<Ref. to 2-7 [T10CI0].>
P1442	Fuel level sensor circuit range/performance problem 2	<Ref. to 2-7 [T10CJ0].>
P1443	Evaporative emission control system vent control function problem	<Ref. to 2-7 [T10CK0].>
P1445	Air assist injector solenoid valve malfunction	<Ref. to 2-7 [T10CL0].>
P1490	Thermostat malfunction	<Ref. to 2-7 [T10CM0].>
P1507	Idle control system malfunction (fail-safe)	<Ref. to 2-7 [T10CN0].>
P1510	Idle air control solenoid valve signal 1 circuit low input	<Ref. to 2-7 [T10CO0].>
P1511	Idle air control solenoid valve signal 1 circuit high input	<Ref. to 2-7 [T10CP0].>
P1512	Idle air control solenoid valve signal 2 circuit low input	<Ref. to 2-7 [T10CQ0].>
P1513	Idle air control solenoid valve signal 2 circuit high input	<Ref. to 2-7 [T10CR0].>
P1514	Idle air control solenoid valve signal 3 circuit low input	<Ref. to 2-7 [T10CS0].>
P1515	Idle air control solenoid valve signal 3 circuit high input	<Ref. to 2-7 [T10CT0].>
P1516	Idle air control solenoid valve signal 4 circuit low input	<Ref. to 2-7 [T10CU0].>
P1517	Idle air control solenoid valve signal 4 circuit high input	<Ref. to 2-7 [T10CV0].>
P1520	Cooling fan relay 1 circuit high input	<Ref. to 2-7 [T10CW0].>
P1540	Vehicle speed sensor malfunction 2	<Ref. to 2-7 [T10CX0].>
P1560	Back-up voltage circuit malfunction	<Ref. to 2-7 [T10CY0].>
P1700	Throttle position sensor circuit malfunction for automatic transmission	<Ref. to 2-7 [T10CZ0].>
P1701	Cruise control set signal circuit malfunction for automatic transmission	<Ref. to 2-7 [T10DA0].>
P1702	Automatic transmission diagnosis input signal circuit low input	<Ref. to 2-7 [T10DB0].>
P1703	Low clutch timing control solenoid valve circuit malfunction	<Ref. to 2-7 [T10DC0].>

DTC No.	Item	Index
P1704	2-4 brake timing control solenoid valve circuit malfunction	<Ref. to 2-7 [T10DD0].>
P1705	2-4 brake pressure control solenoid valve (2-4 brake duty solenoid) circuit malfunction	<Ref. to 2-7 [T10DE0].>
P1722	Automatic transmission diagnosis input signal circuit high input	<Ref. to 2-7 [T10DF0].>
P1742	Automatic transmission diagnosis input signal circuit malfunction	<Ref. to 2-7 [T10DG0].>

**MEMO:**

**B: DTC P0106 — PRESSURE SENSOR CIRCUIT RANGE/PERFORMANCE PROBLEM —**

- **DTC DETECTING CONDITION:**
  - Two consecutive driving cycles with fault

**CAUTION:**

After repair or replacement of faulty parts, conduct CLEAR MEMORY MODE <Ref. to 2-7 [T3D0].> and INSPECTION MODE <Ref. to 2-7 [T3E0].>

● **WIRING DIAGRAM:**

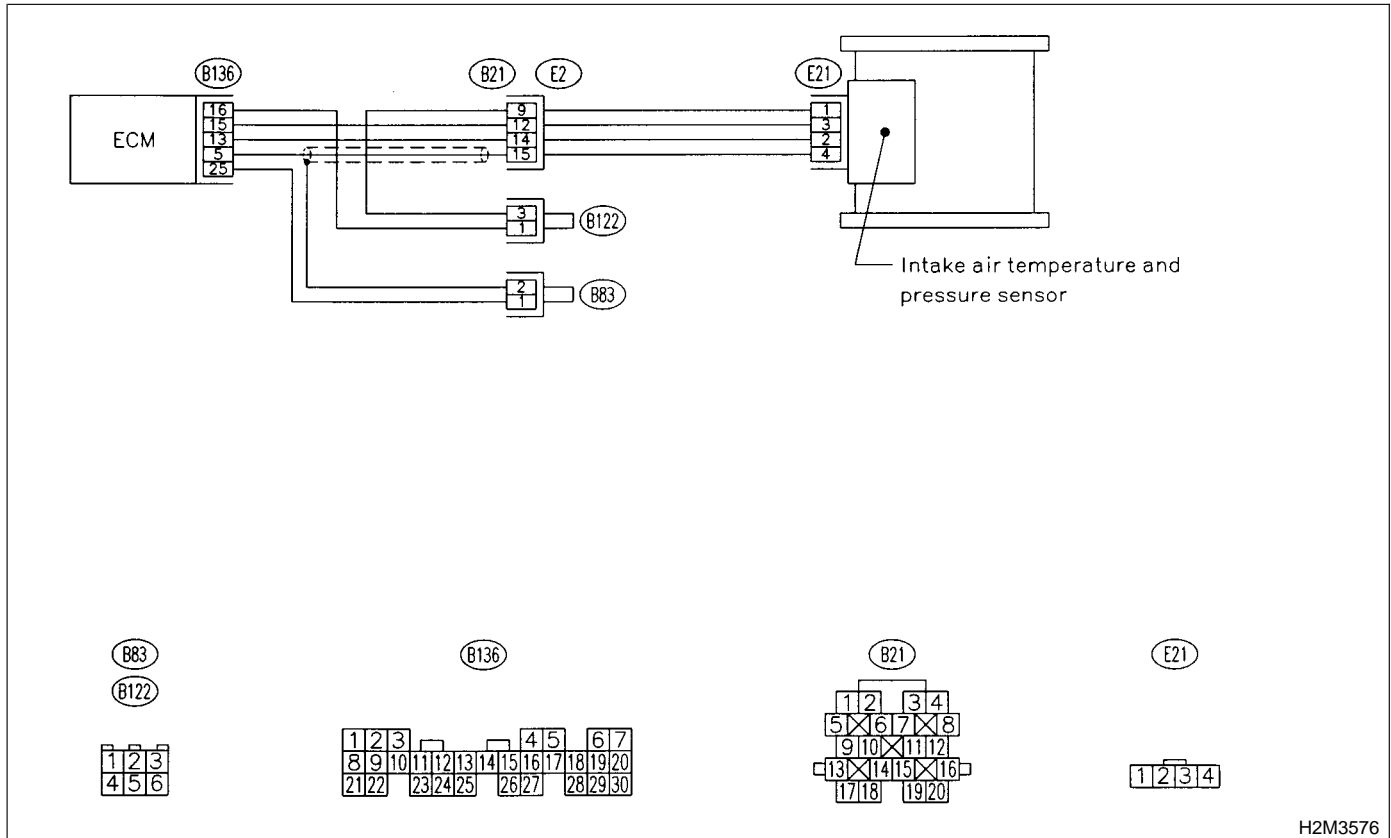

H2M3576

**10B1 : CHECK ANY OTHER DTC ON DISPLAY.**

**NOTE:**

In this case, it is not necessary to inspect DTC P0106.

- CHECK** : Does the Subaru Select Monitor or OBD-II general scan tool indicate DTC P0107, P0108 or P1112?
- YES** : Inspect DTC P0107, P0108 or P1112 using "10. Diagnostics Chart with Trouble Code". <Ref. to 2-7 [T10A0].>
- NO** : Go to step **10B2**.

**10B2 : CHECK AIR INTAKE SYSTEM.**

- CHECK** : Are there holes, loose bolts or disconnection of hose on air intake system?
- YES** : Repair air intake system.
- NO** : Go to step **10B3**.

**10B3 : CHECK PRESSURE SENSOR.**

- 1) Start the engine and warm-up engine until coolant temperature is greater than 60°C (140°F).
- 2) Place the shift lever in the select lever in "N" or "P" position.
- 3) Turn A/C switch to OFF.
- 4) Turn all accessory switches to OFF.
- 5) Read data of intake manifold pressure sensor signal using Subaru Select Monitor or OBD-II general scan tool.

## NOTE:

- Subaru Select Monitor

For detailed operation procedure, refer to the "READ CURRENT DATA SHOWN ON DISPLAY FOR ENGINE". <Ref. to 2-7 [T3C4].>

- OBD-II general scan tool

For detailed operation procedure, refer to the OBD-II General Scan Tool Instruction Manual.

## Specification:

- Intake manifold absolute pressure

Engine speed	Specified value
Ignition ON	73.3 — 106.6 kPa (550 — 800 mmHg, 21.65 — 31.50 inHg)
Idling	20.0 — 46.7 kPa (150 — 350 mmHg, 5.91 — 13.78 inHg)

**CHECK** : *Is the value within the specifications?*

**YES** : Go to step **10B4**.

**NO** : Replace intake air temperature sensor and pressure sensor. <Ref. to 2-7 [W13A0].>

**10B4 : CHECK THROTTLE POSITION.**

Read data of throttle position signal using Subaru Select Monitor or OBD-II general scan tool.

## NOTE:

- Subaru Select Monitor

For detailed operation procedure, refer to the "READ CURRENT DATA SHOWN ON DISPLAY FOR ENGINE". <Ref. to 2-7 [T3C4].>

- OBD-II general scan tool

For detailed operation procedure, refer to the OBD-II General Scan Tool Instruction Manual.

**CHECK** : *Is throttle positioning ratio equal to or less than 5% when throttle is fully closed?*

**YES** : Go to step **10B5**.

**NO** : Adjust or replace throttle position sensor. <Ref. to 2-7 [W10A0].>

**10B5 : CHECK THROTTLE POSITION.**

**CHECK** : *Is throttle positioning ratio equal to or more than 85% when throttle is fully open?*

**YES** : Replace intake air temperature and pressure sensor. <Ref. to 2-7 [W11A0].>

**NO** : Replace throttle position sensor. <Ref. to 2-7 [W10A0].>



**C: DTC P0107 — PRESSURE SENSOR CIRCUIT LOW INPUT —**

**● DTC DETECTING CONDITION:**

- Immediately at fault recognition

**CAUTION:**

After repair or replacement of faulty parts, conduct CLEAR MEMORY MODE <Ref. to 2-7 [T3D0].> and INSPECTION MODE <Ref. to 2-7 [T3E0].>

**● WIRING DIAGRAM:**

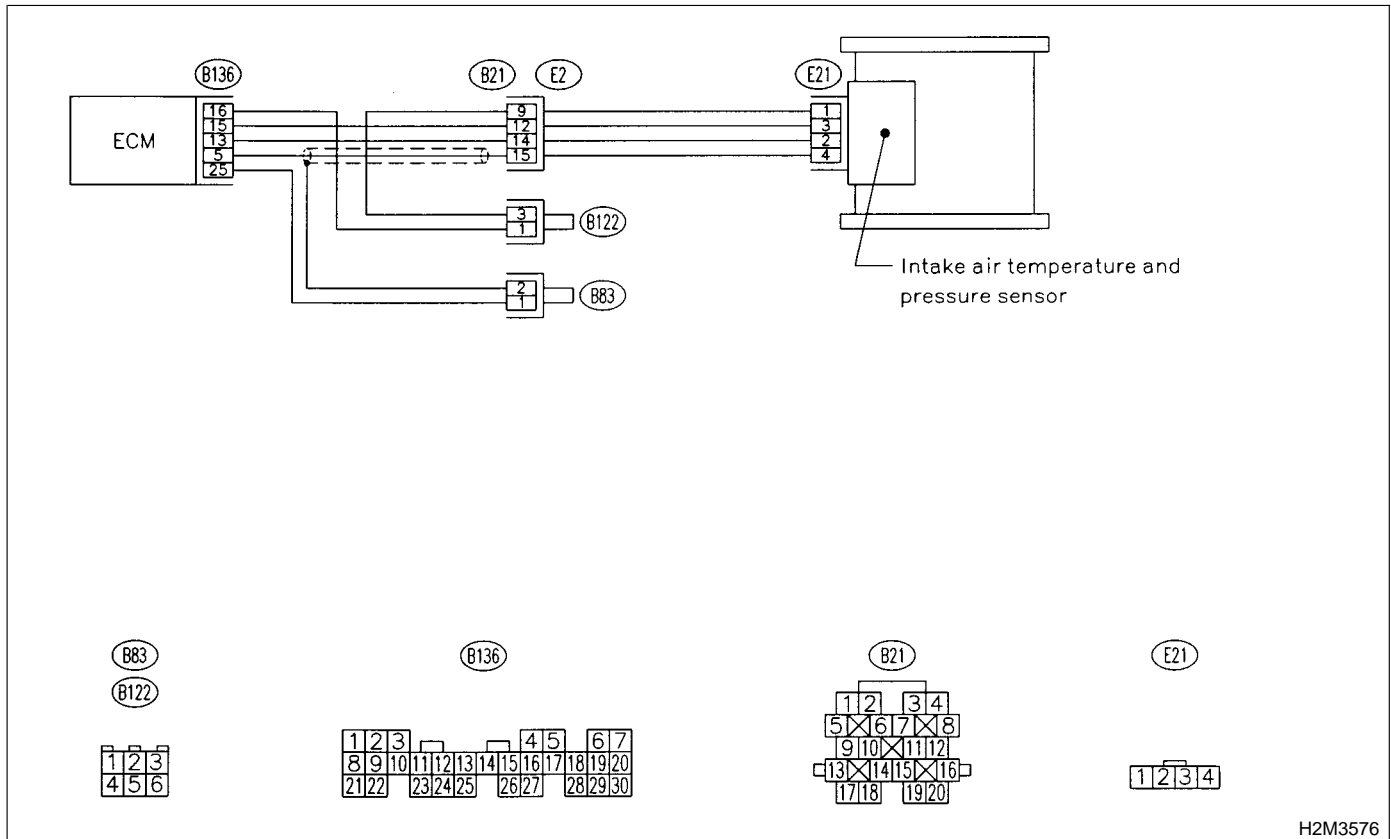

H2M3576

**10C1 : CHECK CURRENT DATA.**

- 1) Start engine.
- 2) Read the data of intake manifold absolute pressure signal using Subaru Select Monitor or OBD-II general scan tool.

NOTE:

- Subaru Select Monitor  
For detailed operation procedure, refer to the "READ CURRENT DATA SHOWN ON DISPLAY FOR ENGINE". <Ref. to 2-7 [T3C4].>
- OBD-II general scan tool  
For detailed operation procedures, refer to the OBD-II General Scan Tool Instruction Manual.

**CHECK** : *Is the value less than 13.3 kPa (100 mmHg, 3.94 inHg)?*

**YES** : Go to step 10C3.

**NO** : Go to step 10C2.

**10C2 : CHECK POOR CONTACT.**

Check poor contact in ECM and pressure sensor connector. <Ref. to 2-7 [T3C8].>

**CHECK** : *Is there poor contact in ECM or pressure sensor connector?*

**YES** : Repair poor contact in ECM or pressure sensor connector.

**NO** : Even if MIL lights up, the circuit has returned to a normal condition at this time.

**10C3 : CHECK INPUT SIGNAL FOR ECM.**

Measure voltage between ECM connector and chassis ground.

**Connector & terminal**  
*(B136) No. 15 (+) — Chassis ground (-):*

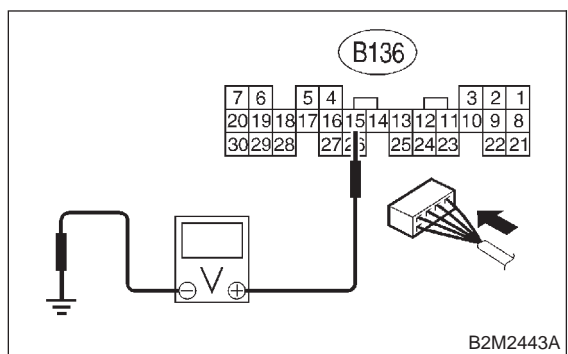

**CHECK** : *Is the voltage more than 4.5 V?*

**YES** : Go to step 10C5.

**NO** : Go to step 10C4.

**10C4 : CHECK INPUT SIGNAL FOR ECM.**

Measure voltage between ECM connector and chassis ground.

**Connector & terminal**  
*(B136) No. 15 (+) — Chassis ground (-):*

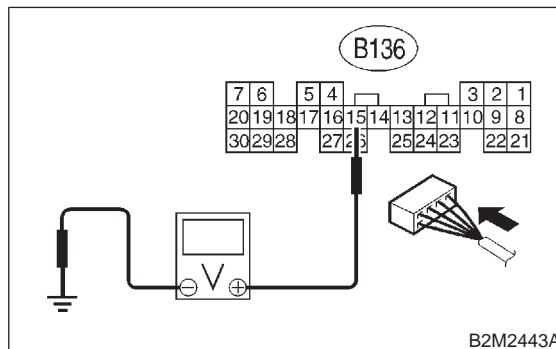

**CHECK** : *Does the voltage change more than 4.5 V by shaking harness and connector of ECM while monitoring the value with voltage meter?*

**YES** : Repair poor contact in ECM connector.

**NO** : Contact with SOA service.

NOTE:

Inspection by DTM is required, because probable cause is deterioration of multiple parts.

**10C5 : CHECK INPUT SIGNAL FOR ECM.**

Measure voltage between ECM and chassis ground.

**Connector & terminal**  
*(B136) No. 5 (+) — Chassis ground (-):*

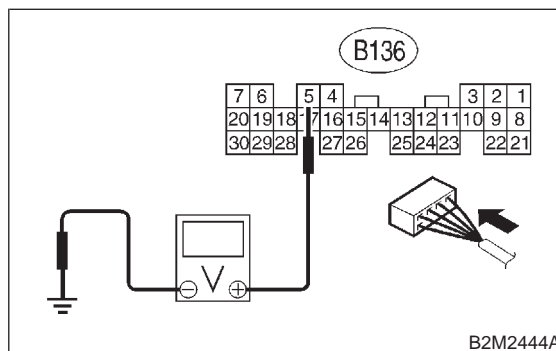

**CHECK** : *Is the voltage less than 0.2 V?*

**YES** : Go to step 10C7.

**NO** : Go to step 10C6.

**10C6 : CHECK INPUT SIGNAL FOR ECM.  
(USING SUBARU SELECT MONI-  
TOR.)**

Read data of atmospheric absolute pressure signal using Subaru Select Monitor.

NOTE:

- Subaru Select Monitor

For detailed operation procedure, refer to the "READ CURRENT DATA SHOWN ON DISPLAY FOR ENGINE". <Ref. to 2-7 [T3C4].>

**CHECK** : *Does the value change more than 13.3 kPa (100 mmHg, 3.94 inHg) by shaking harness and connector of ECM while monitoring the value with Subaru Select Monitor?*

- YES** : Repair poor contact in ECM connector.  
**NO** : Go to step 10C7.

**10C7 : CHECK HARNESS BETWEEN ECM  
AND INTAKE AIR TEMPERATURE  
AND PRESSURE SENSOR CON-  
NECTOR.**

- 1) Turn ignition switch to OFF.
- 2) Disconnect connector from intake air temperature and pressure sensor.
- 3) Turn ignition switch to ON.
- 4) Measure voltage between intake air temperature sensor and pressure sensor connector and engine ground.

**Connector & terminal**

**(E21) No. 3 (+) — Engine ground (-):**

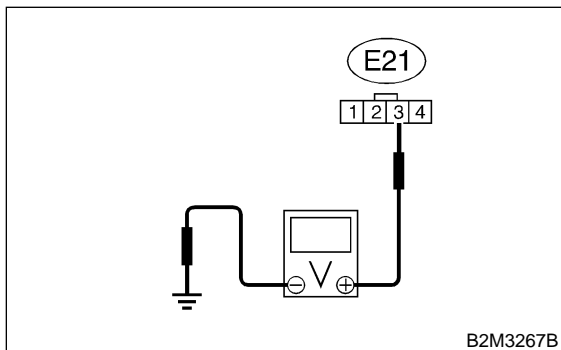

- CHECK** : *Is the voltage more than 4.5 V?*  
**YES** : Go to step 10C8.  
**NO** : Repair open circuit in harness between ECM and intake air temperature and pressure sensor connector.

**10C8 : CHECK HARNESS BETWEEN ECM  
AND INTAKE AIR TEMPERATURE  
AND PRESSURE SENSOR CON-  
NECTOR.**

- 1) Turn ignition switch to OFF.
- 2) Disconnect connector from ECM.
- 3) Measure resistance of harness between ECM and intake air temperature and pressure sensor connector.

**Connector & terminal**

**(B136) No. 16 — (E21) No. 1:**

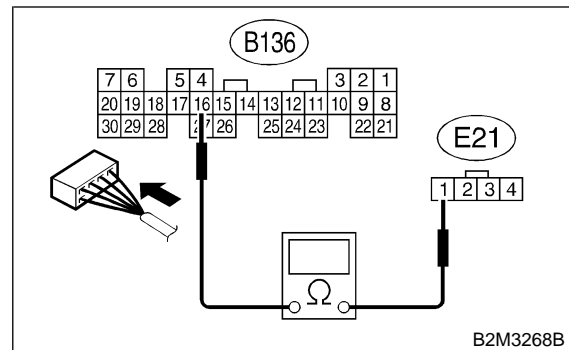

- CHECK** : *Is the resistance less than 1 Ω?*  
**YES** : Go to step 10C9.  
**NO** : Repair open circuit in harness between ECM and intake air temperature and pressure sensor connector.

**10C9 : CHECK HARNESS BETWEEN ECM AND INTAKE AIR TEMPERATURE AND PRESSURE SENSOR CONNECTOR.**

Measure resistance of harness between intake air temperature and pressure sensor connector and engine ground.

**Connector & terminal**

**(E21) No. 4 — Engine ground:**

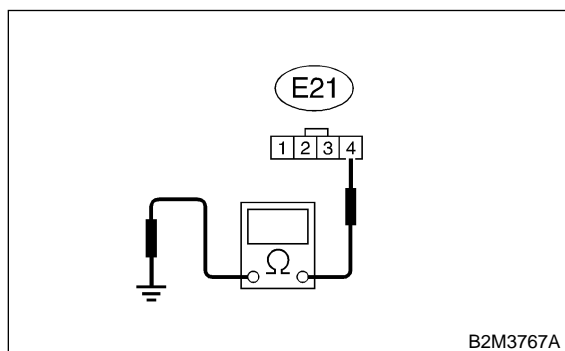

- CHECK** : **Is the resistance more than 500 k $\Omega$ ?**
- YES** : Go to step **10C10**.
- NO** : Repair ground short circuit in harness between ECM and intake air temperature and pressure sensor connector.

**10C10 : CHECK POOR CONTACT.**

Check poor contact in intake manifold pressure sensor connector. <Ref. to FOREWORD [T3C1].>

- CHECK** : **Is there poor contact in intake manifold pressure sensor connector?**
- YES** : Repair poor contact in intake air temperature and pressure sensor connector.
- NO** : Replace intake air temperature and pressure sensor. <Ref. to 2-7 [W11A0].>

**D: DTC P0108 — PRESSURE SENSOR CIRCUIT HIGH INPUT —**

**• DTC DETECTING CONDITION:**

- Immediately at fault recognition

**CAUTION:**

After repair or replacement of faulty parts, conduct CLEAR MEMORY MODE <Ref. to 2-7 [T3D0].> and INSPECTION MODE <Ref. to 2-7 [T3E0].>

**• WIRING DIAGRAM:**

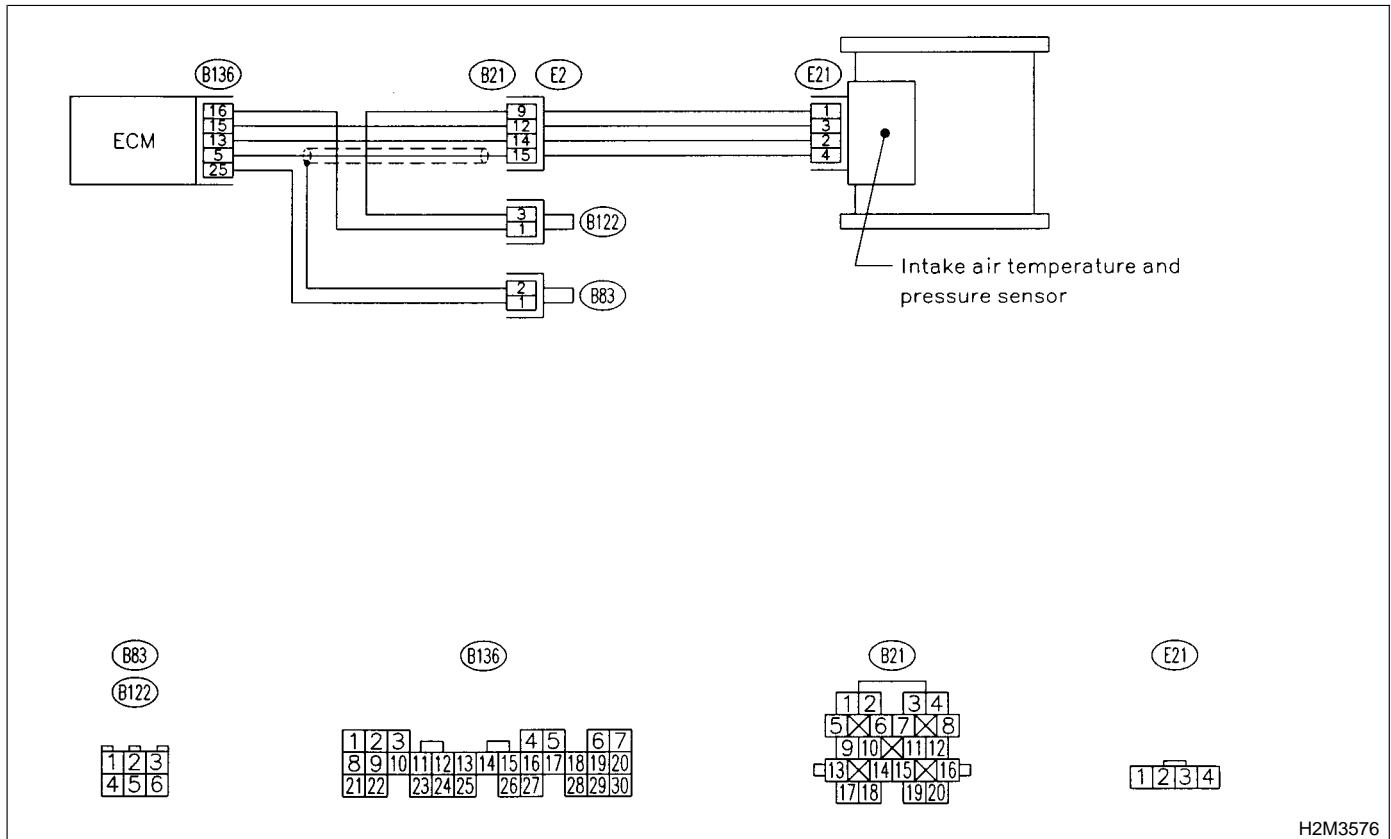

H2M3576

**10D1 : CHECK CURRENT DATA.**

- 1) Start engine.
- 2) Read the data of intake manifold absolute pressure signal using Subaru Select Monitor or OBD-II general scan tool.

NOTE:

- Subaru Select Monitor  
For detailed operation procedure, refer to the "READ CURRENT DATA SHOWN ON DISPLAY FOR ENGINE". <Ref. to 2-7 [T3C4].>
- OBD-II general scan tool  
For detailed operation procedures, refer to the OBD-II General Scan Tool Instruction Manual.

**CHECK** : Is the value more than 119.5 kPa (896.5 mmHg, 35.29 inHg)?

**YES** : Go to step 10D9.

**NO** : Go to step 10D2.

**10D2 : CHECK INPUT SIGNAL FOR ECM.**

Measure voltage between ECM connector and chassis ground.

**Connector & terminal**  
(B136) No. 15 (+) — Chassis ground (-):

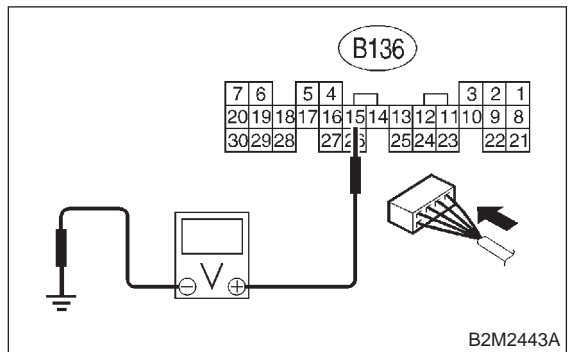

**CHECK** : Is the voltage more than 4.5 V?

**YES** : Go to step 10D4.

**NO** : Go to step 10D3.

**10D3 : CHECK INPUT SIGNAL FOR ECM.**

Measure voltage between ECM connector and chassis ground.

**Connector & terminal**  
(B136) No. 15 (+) — Chassis ground (-):

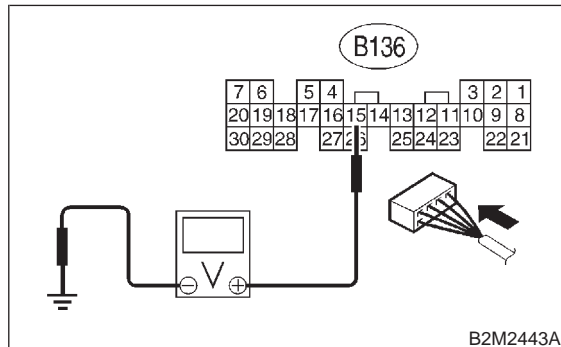

**CHECK** : Does the voltage change more than 4.5 V by shaking harness and connector of ECM while monitoring the value with voltage meter?

**YES** : Repair poor contact in ECM connector.

**NO** : Contact with SOA service.

NOTE:

Inspection by DTM is required, because probable cause is deterioration of multiple parts.

**10D4 : CHECK INPUT SIGNAL FOR ECM.**

Measure voltage between ECM connector and chassis ground.

**Connector & terminal**  
(B136) No. 5 (+) — Chassis ground (-):

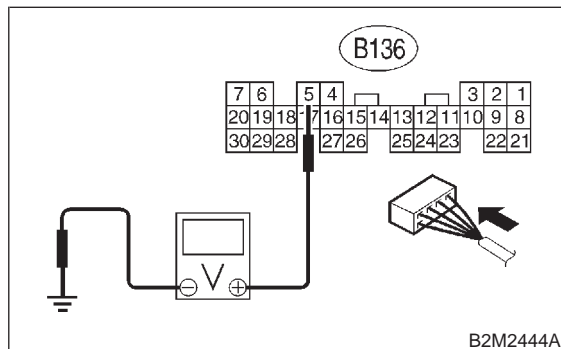

**CHECK** : Is the voltage less than 0.2 V?

**YES** : Go to step 10D6.

**NO** : Go to step 10D5.

**10D5 : CHECK INPUT SIGNAL FOR ECM. (USING SUBARU SELECT MONITOR.)**

Read data of atmospheric absolute pressure signal using Subaru Select Monitor.

NOTE:

- Subaru Select Monitor

For detailed operation procedure, refer to the "READ CURRENT DATA SHOWN ON DISPLAY FOR ENGINE". <Ref. to 2-7 [T3C4].>

**CHECK** : Does the value change more than 13.3 kPa (100 mmHg, 3.94 inHg) by shaking harness and connector of ECM while monitoring the value with Subaru Select Monitor?

- YES** : Repair poor contact in ECM connector.
- NO** : Go to step 10D6.

**10D6 : CHECK HARNESS BETWEEN ECM AND INTAKE AIR TEMPERATURE AND PRESSURE SENSOR CONNECTOR.**

- 1) Turn ignition switch to OFF.
- 2) Disconnect connector from intake air temperature and pressure sensor.
- 3) Turn ignition switch to ON.
- 4) Measure voltage between intake air temperature and pressure sensor connector and engine ground.

**Connector & terminal**

(E21) No. 3 (+) — Engine ground (-):

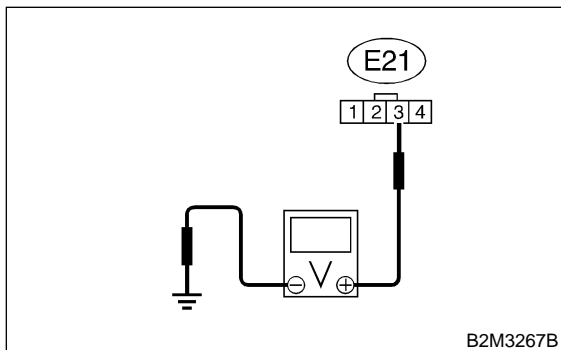

- CHECK** : Is the voltage more than 4.5 V?
- YES** : Go to step 10D7.
- NO** : Repair open circuit in harness between ECM and intake air temperature and pressure sensor connector.

**10D7 : CHECK HARNESS BETWEEN ECM AND INTAKE AIR TEMPERATURE AND PRESSURE SENSOR CONNECTOR.**

- 1) Turn ignition switch to OFF.
- 2) Disconnect connector from ECM.
- 3) Measure resistance of harness between ECM and intake air temperature and pressure sensor connector.

**Connector & terminal**

(B136) No. 5 — (E21) No. 4:

(B136) No. 16 — (E21) No. 1:

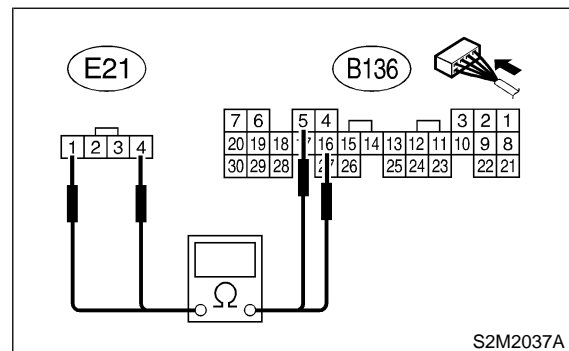

- CHECK** : Is the resistance less than 1 Ω?
- YES** : Go to step 10D8.
- NO** : Repair open circuit in harness between ECM and intake air temperature and pressure sensor connector.

**10D8 : CHECK POOR CONTACT.**

Check poor contact in intake air temperature and pressure sensor connector. <Ref. to FOREWORD [T3C1].>

- CHECK** : Is there poor contact in intake manifold pressure sensor connector?
- YES** : Repair poor contact in intake air temperature and pressure sensor connector.
- NO** : Replace intake air temperature and pressure sensor. <Ref. to 2-7 [W11A0].>

**10D9 : CHECK HARNESS BETWEEN ECM AND INTAKE AIR TEMPERATURE AND PRESSURE SENSOR CONNECTOR.**

- 1) Turn ignition switch to OFF and Subaru Select Monitor or the OBD-II general scan tool switch to OFF.
- 2) Disconnect connector from intake air temperature and pressure sensor.
- 3) Turn ignition switch to ON and Subaru Select Monitor or the OBD-II general scan tool switch to ON.
- 4) Read data of intake manifold absolute pressure signal using Subaru Select Monitor or OBD-II general scan tool.

## NOTE:

- Subaru Select Monitor

For detailed operation procedure, refer to the "READ CURRENT DATA SHOWN ON DISPLAY FOR ENGINE". <Ref. to 2-7 [T3C4].>

- OBD-II general scan tool

For detailed operation procedures, refer to the OBD-II General Scan Tool Instruction Manual.

**CHECK** : *Is the value more than 119.5 kPa (896.5 mmHg, 35.29 inHg)?*

**YES** : Repair battery short circuit in harness between ECM and intake air temperature and pressure sensor connector.

**NO** : Replace intake air temperature and pressure sensor. <Ref. to 2-7 [W11A0].>



**E: DTC P0111 — INTAKE AIR TEMPERATURE SENSOR CIRCUIT RANGE/ PERFORMANCE PROBLEM —**

- **DTC DETECTING CONDITION:**
  - Immediately at fault recognition
- **TROUBLE SYMPTOM:**
  - Erroneous idling
  - Poor driving performance

**CAUTION:**

After repair or replacement of faulty parts, conduct CLEAR MEMORY MODE <Ref. to 2-7 [T3D0].> and INSPECTION MODE <Ref. to 2-7 [T3E0].>

● **WIRING DIAGRAM:**

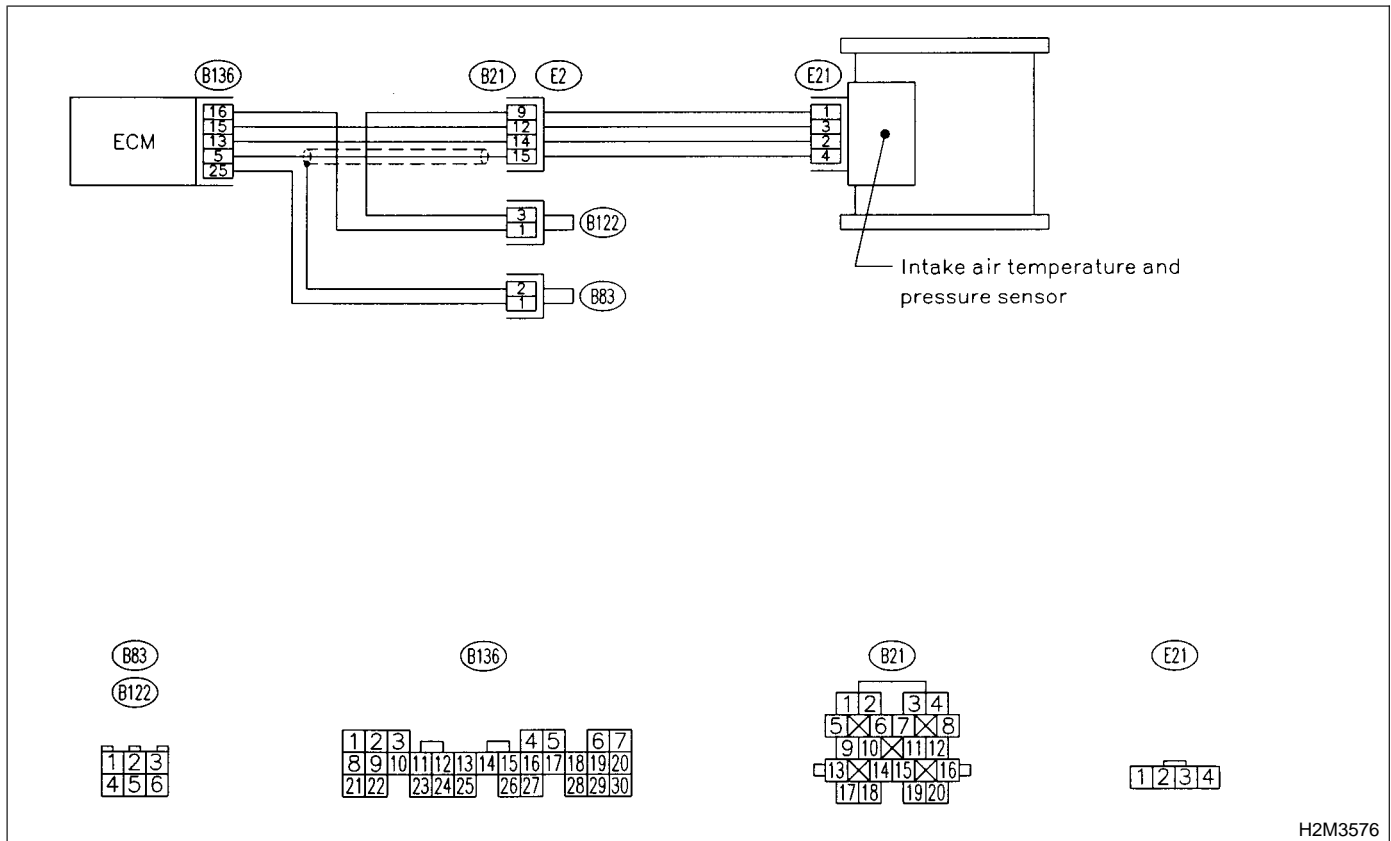

H2M3576

**10E1 : CHECK ANY OTHER DTC ON DISPLAY.**

**CHECK** : *Does the Subaru Select Monitor or OBD-II general scan tool indicate DTC P0112, P0113, P0116, P0117 or P0125?*

**YES** : Inspect DTC P0112, P0113, P0116, P0117 or P0125 using "10. Diagnostics Chart with Trouble Code". <Ref. to 2-7 [T10A0].>

NOTE:

In this case, it is not necessary to inspect DTC P0111.

**NO** : Go to step **10E2**.

**10E2 : CHECK ENGINE COOLANT TEMPERATURE.**

- 1) Start the engine and warm it up completely.
- 2) Measure engine coolant temperature using Subaru Select Monitor or OBD-II general scan tool.

NOTE:

- Subaru Select Monitor

For detailed operation procedure, refer to the "READ CURRENT DATA SHOWN ON DISPLAY FOR ENGINE". <Ref. to 2-7 [T3C4].>

- OBD-II general scan tool

For detailed operation procedures, refer to the OBD-II General Scan Tool Instruction Manual.

**CHECK** : *Is the engine coolant temperature between 75°C (167°F) and 95°C (203°F)?*

**YES** : Replace intake air temperature and pressure sensor. <Ref. to 2-7 [W11A0].>

**NO** : Inspect DTC P0125 using "10. Diagnostics Chart with Trouble Code". <Ref. to 2-7 [T10A0].>

**F: DTC P0112 — INTAKE AIR TEMPERATURE SENSOR CIRCUIT LOW INPUT**

- **DTC DETECTING CONDITION:**
  - Immediately at fault recognition
- **TROUBLE SYMPTOM:**
  - Erroneous idling
  - Poor driving performance

**CAUTION:**

After repair or replacement of faulty parts, conduct CLEAR MEMORY MODE <Ref. to 2-7 [T3D0].> and INSPECTION MODE <Ref. to 2-7 [T3E0].>

● **WIRING DIAGRAM:**

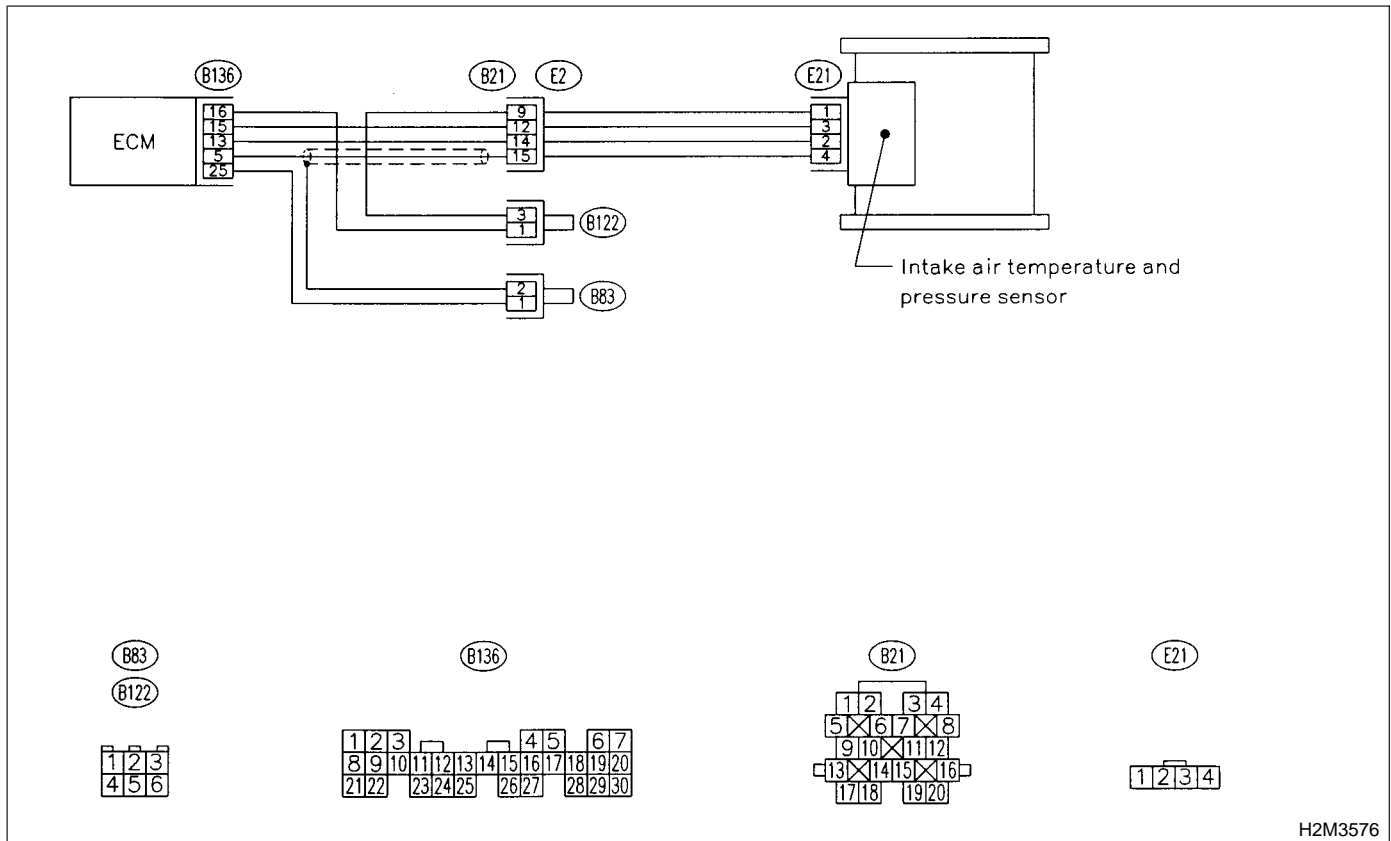

H2M3576

**10F1 : CHECK CURRENT DATA.**

- 1) Start engine.
- 2) Read data of intake air temperature sensor signal using Subaru Select Monitor or the OBD-II general scan tool.

## NOTE:

- Subaru Select Monitor

For detailed operation procedure, refer to the "READ CURRENT DATA SHOWN ON DISPLAY FOR ENGINE". <Ref. to 2-7 [T3C4].>

- OBD-II general scan tool

For detailed operation procedure, refer to the OBD-II General Scan Tool Instruction Manual.

**CHECK** : *Is the value greater than 120°C (248°F)?*

**YES** : Go to step **10F2**.

**NO** : Repair poor contact.

## NOTE:

In this case, repair the following:

- Poor contact in intake air temperature and pressure sensor
- Poor contact in ECM
- Poor contact in coupling connector (B21)
- Poor contact in joint connector (B83 and B122)

**10F2 : CHECK HARNESS BETWEEN INTAKE AIR TEMPERATURE AND PRESSURE SENSOR AND ECM CONNECTOR.**

- 1) Turn ignition switch to OFF.
- 2) Disconnect connector from intake air temperature and pressure sensor.
- 3) Turn ignition switch to ON.
- 4) Read data of intake air temperature sensor signal using Subaru Select Monitor or the OBD-II general scan tool.

## NOTE:

- Subaru Select Monitor

For detailed operation procedure, refer to the "READ CURRENT DATA SHOWN ON DISPLAY FOR ENGINE". <Ref. to 2-7 [T3C4].>

- OBD-II general scan tool

For detailed operation procedure, refer to the OBD-II General Scan Tool Instruction Manual.

**CHECK** : *Is the value less than -40°C (-40°F)?*

**YES** : Replace intake air temperature and pressure sensor. <Ref. to 2-7 [W11A0].>

**NO** : Repair ground short circuit in harness between intake air temperature sensor and ECM connector.

## G: DTC P0113 — INTAKE AIR TEMPERATURE SENSOR CIRCUIT HIGH INPUT —

- **DTC DETECTING CONDITION:**
  - Immediately at fault recognition
- **TROUBLE SYMPTOM:**
  - Erroneous idling
  - Poor driving performance

**CAUTION:**

After repair or replacement of faulty parts, conduct CLEAR MEMORY MODE <Ref. to 2-7 [T3D0].> and INSPECTION MODE <Ref. to 2-7 [T3E0].>

● **WIRING DIAGRAM:**

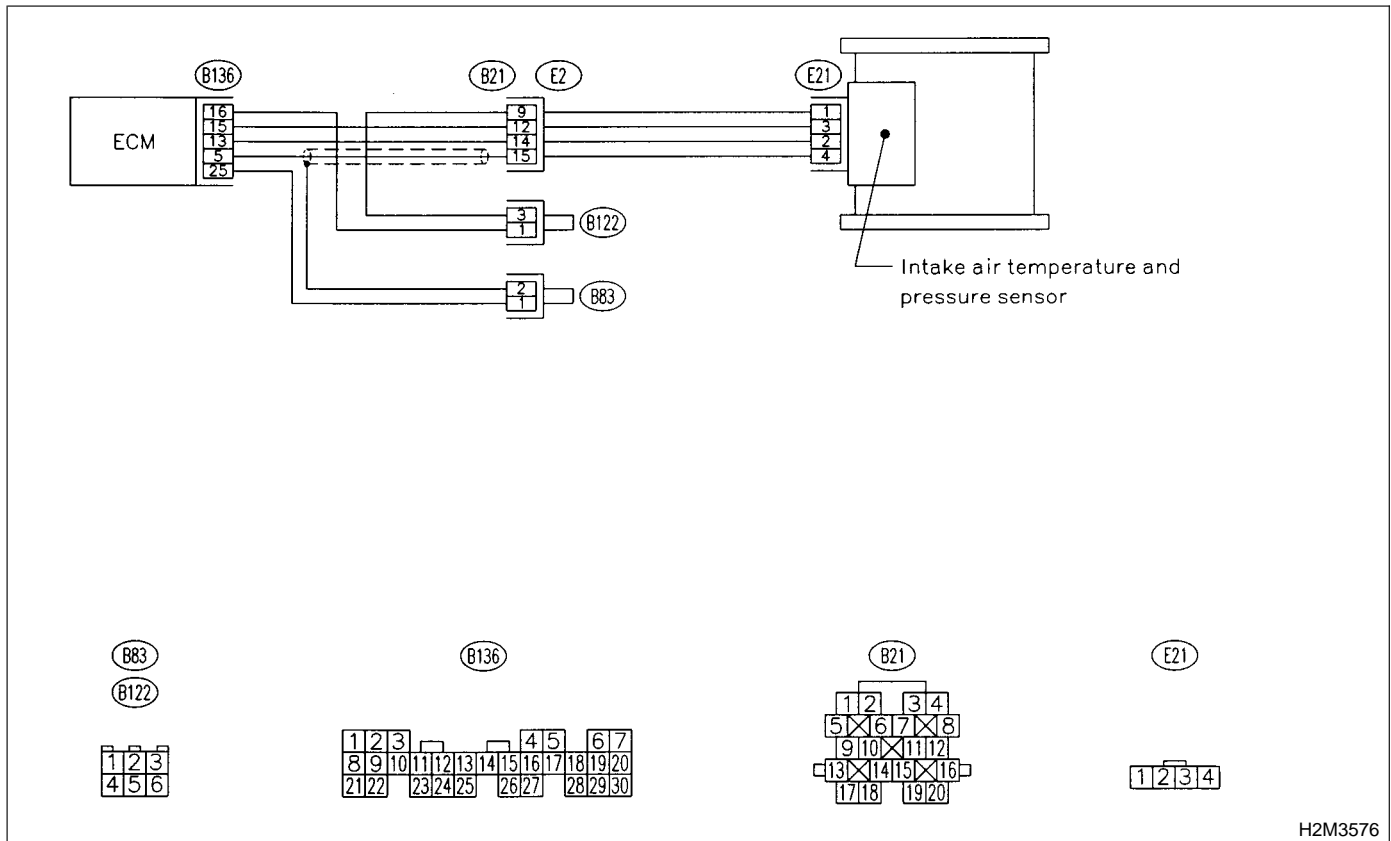

H2M3576

**10G1 : CHECK CURRENT DATA.**

- 1) Start engine.
- 2) Read data of intake air temperature sensor signal using Subaru Select Monitor or the OBD-II general scan tool.

**NOTE:**

- Subaru Select Monitor

For detailed operation procedure, refer to the "READ CURRENT DATA SHOWN ON DISPLAY FOR ENGINE". <Ref. to 2-7 [T3C4].>

- OBD-II general scan tool

For detailed operation procedure, refer to the OBD-II General Scan Tool Instruction Manual.

**CHECK** : **Is the value less than  $-40^{\circ}\text{C}$  ( $-40^{\circ}\text{F}$ )?**

**YES** : Go to step **10G2**.

**NO** : Repair poor contact.

**NOTE:**

In this case, repair the following:

- Poor contact in intake air temperature and pressure sensor
- Poor contact in ECM
- Poor contact in coupling connector (B21)
- Poor contact in joint connector (B83 and B122)

**10G2 : CHECK HARNESS BETWEEN INTAKE AIR TEMPERATURE AND PRESSURE SENSOR AND ECM CONNECTOR.**

- 1) Turn ignition switch to OFF.
- 2) Disconnect connector from intake air temperature and pressure sensor.
- 3) Measure voltage between intake air temperature and pressure sensor connector and engine ground.

**Connector & terminal**

**(E21) No. 2 (+) — Engine ground (-):**

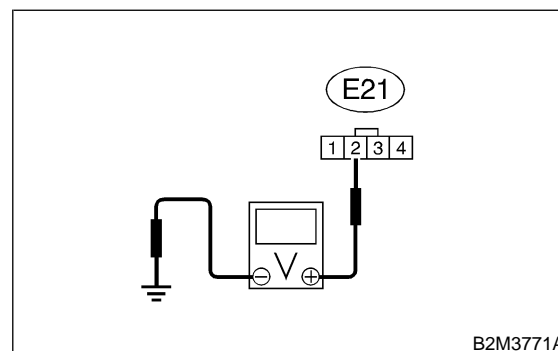

**CHECK** : **Is the voltage more than 10 V?**

**YES** : Repair battery short circuit in harness between intake air temperature and pressure sensor and ECM connector.

**NO** : Go to step **10G3**.

**10G3 : CHECK HARNESS BETWEEN INTAKE AIR TEMPERATURE AND PRESSURE SENSOR AND ECM CONNECTOR.**

- 1) Turn ignition switch to ON.
- 2) Measure voltage between intake air temperature and pressure sensor connector and engine ground.

**Connector & terminal**

**(E21) No. 2 (+) — Engine ground (-):**

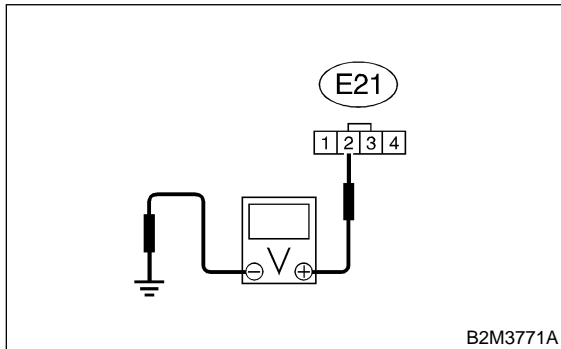

- CHECK** : **Is the voltage more than 10 V?**
- YES** : Repair battery short circuit in harness between intake air temperature and pressure sensor and ECM connector.
- NO** : Go to step **10G4**.

**10G4 : CHECK HARNESS BETWEEN INTAKE AIR TEMPERATURE AND PRESSURE SENSOR AND ECM CONNECTOR.**

Measure voltage between intake air temperature and pressure sensor connector and engine ground.

**Connector & terminal**

**(E21) No. 2 (+) — Engine ground (-):**

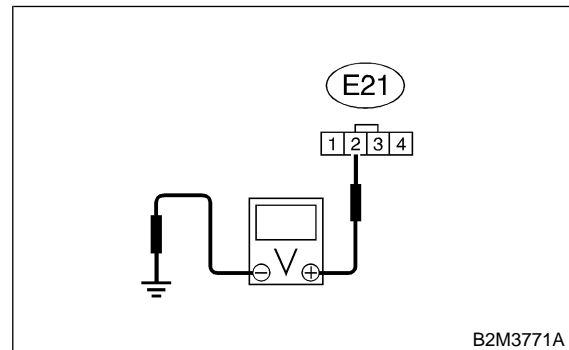

- CHECK** : **Is the voltage more than 3 V?**
- YES** : Go to step **10G5**.
- NO** : Repair harness and connector.

**NOTE:**

In this case, repair the following:

- Open circuit in harness between intake air temperature and pressure sensor and ECM connector
- Poor contact in intake air temperature and pressure sensor
- Poor contact in ECM
- Poor contact in coupling connector (B21)
- Poor contact in joint connector (B83 and B122)

**10G5 : CHECK HARNESS BETWEEN INTAKE AIR TEMPERATURE AND PRESSURE SENSOR AND ECM CONNECTOR.**

- 1) Turn ignition switch to OFF.
- 2) Measure resistance of harness between intake air temperature and pressure sensor connector and engine ground.

**Connector & terminal**

**(E21) No. 1 — Engine ground:**

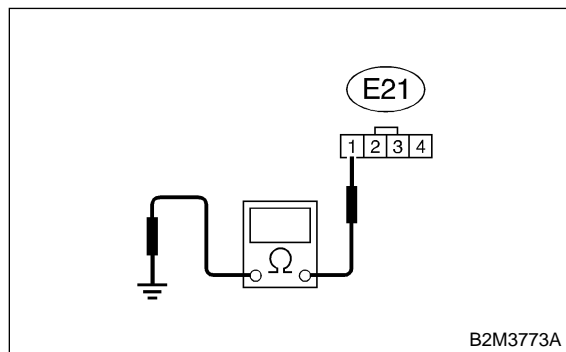

**CHECK** : **Is the resistance less than 5  $\Omega$ ?**

**YES** : Replace intake air temperature and pressure sensor. <Ref. to 2-7 [W13A0].>

**NO** : Repair harness and connector.

**NOTE:**

In this case, repair the following:

- Open circuit in harness between intake air temperature and pressure sensor and ECM connector
- Poor contact in intake air temperature and pressure sensor
- Poor contact in ECM
- Poor contact in coupling connector (B21)
- Poor contact in joint connector (B83 and B122)



**H: DTC P0116 — ENGINE COOLANT TEMPERATURE SENSOR CIRCUIT LOW INPUT —**

- **DTC DETECTING CONDITION:**
  - Immediately at fault recognition
- **TROUBLE SYMPTOM:**
  - Hard to start
  - Erroneous idling
  - Poor driving performance

**CAUTION:**

After repair or replacement of faulty parts, conduct CLEAR MEMORY MODE <Ref. to 2-7 [T3D0].> and INSPECTION MODE <Ref. to 2-7 [T3E0].>

● **WIRING DIAGRAM:**

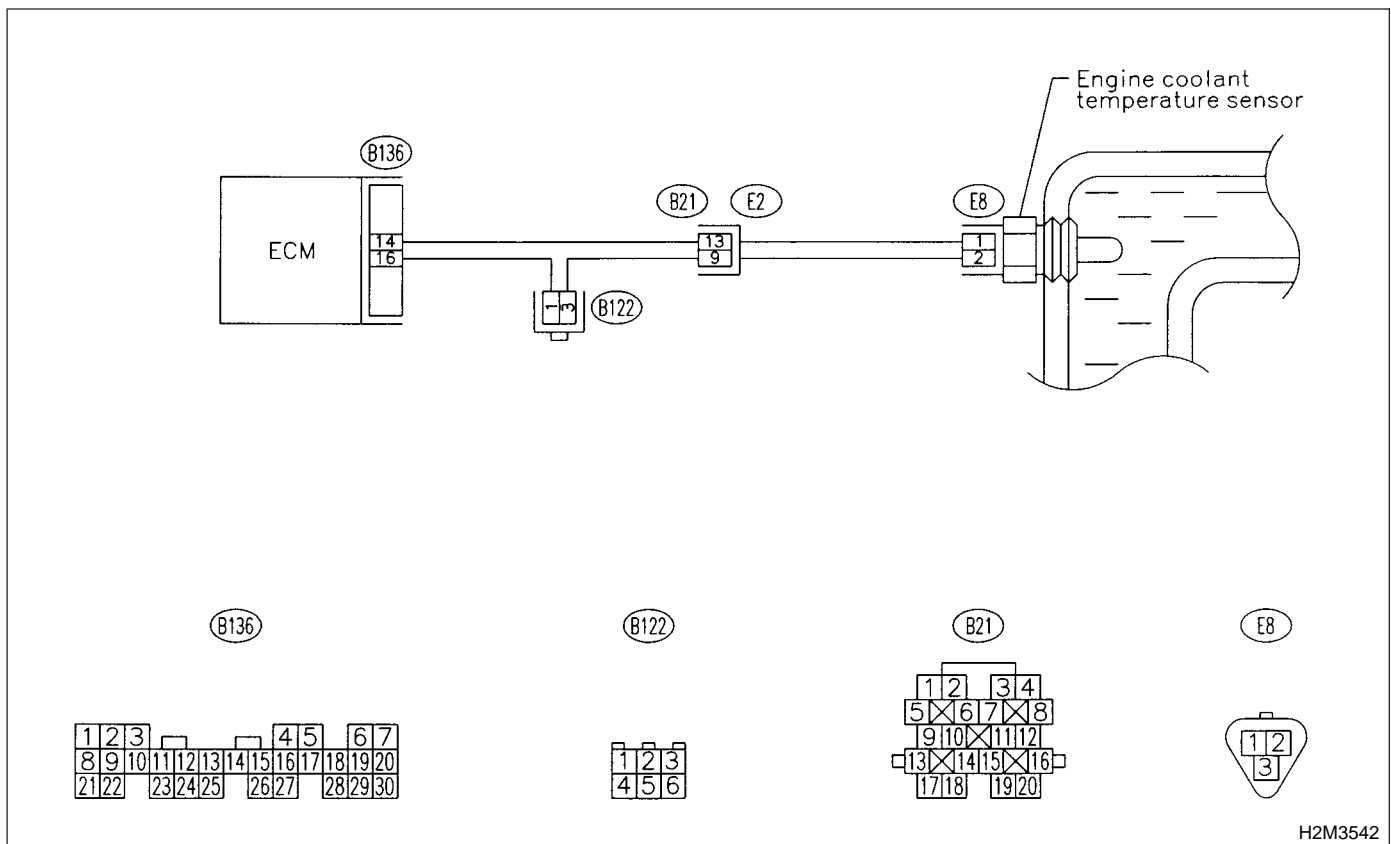

H2M3542

**10H1 : CHECK CURRENT DATA.**

- 1) Start engine.
- 2) Read data of engine coolant temperature sensor signal using Subaru Select Monitor or OBD-II general scan tool.

## NOTE:

- Subaru Select Monitor

For detailed operation procedure, refer to the "READ CURRENT DATA SHOWN ON DISPLAY FOR ENGINE". <Ref. to 2-7 [T3C4].>

- OBD-II general scan tool

For detailed operation procedures, refer to the OBD-II General Scan Tool Instruction Manual.

**CHECK** : ***Is the value greater than 150°C (302°F)?***

**YES** : Go to step **10H2**.

**NO** : Repair poor contact.

## NOTE:

In this case, repair the following:

- Poor contact in engine coolant temperature sensor
- Poor contact in ECM
- Poor contact in coupling connector (B21)
- Poor contact in joint connector (B122)

**10H2 : CHECK HARNESS BETWEEN ENGINE COOLANT TEMPERATURE SENSOR AND ECM CONNECTOR.**

- 1) Turn ignition switch to OFF.
- 2) Disconnect connector from engine coolant temperature sensor.
- 3) Turn ignition switch to ON.
- 4) Read data of engine coolant temperature sensor signal using Subaru Select Monitor or OBD-II general scan tool.

## NOTE:

- Subaru Select Monitor

For detailed operation procedure, refer to the "READ CURRENT DATA SHOWN ON DISPLAY FOR ENGINE". <Ref. to 2-7 [T3C4].>

- OBD-II general scan tool

For detailed operation procedures, refer to the OBD-II General Scan Tool Instruction Manual.

**CHECK** : ***Is the value less than -40°C (-40°F)?***

**YES** : Replace engine coolant temperature sensor. <Ref. to 2-7 [W4A0].>

**NO** : Repair ground short circuit in harness between engine coolant temperature sensor and ECM connector.

**I: DTC P0117 — ENGINE COOLANT TEMPERATURE SENSOR CIRCUIT HIGH INPUT —**

- **DTC DETECTING CONDITION:**
  - Immediately at fault recognition
- **TROUBLE SYMPTOM:**
  - Hard to start
  - Erroneous idling
  - Poor driving performance

**CAUTION:**

After repair or replacement of faulty parts, conduct CLEAR MEMORY MODE <Ref. to 2-7 [T3D0].> and INSPECTION MODE <Ref. to 2-7 [T3E0].>

● **WIRING DIAGRAM:**

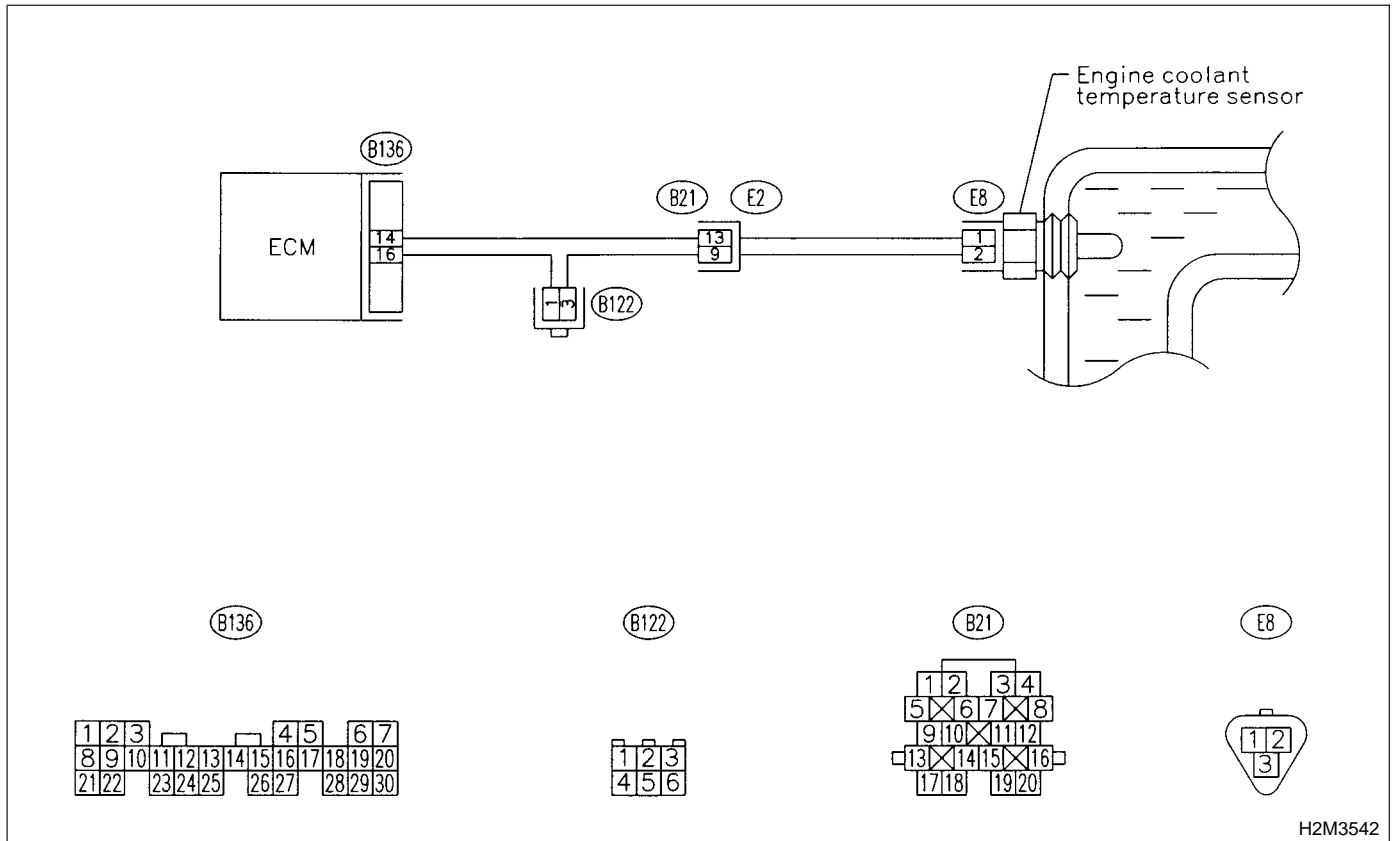

**1011 : CHECK CURRENT DATA.**

- 1) Start engine.
- 2) Read data of engine coolant temperature sensor signal using Subaru Select Monitor or OBD-II general scan tool.

## NOTE:

- Subaru Select Monitor

For detailed operation procedure, refer to the "READ CURRENT DATA SHOWN ON DISPLAY FOR ENGINE". <Ref. to 2-7 [T3C4].>

- OBD-II general scan tool

For detailed operation procedures, refer to the OBD-II General Scan Tool Instruction Manual.

**CHECK** : **Is the value less than  $-40^{\circ}\text{C}$  ( $-40^{\circ}\text{F}$ )?**

**YES** : Go to step **1012**.

**NO** : Repair poor contact.

## NOTE:

In this case, repair the following:

- Poor contact in engine coolant temperature sensor
- Poor contact in ECM
- Poor contact in coupling connector (B21)
- Poor contact in joint connector (B122)

**1012 : CHECK HARNESS BETWEEN ENGINE COOLANT TEMPERATURE SENSOR AND ECM CONNECTOR.**

- 1) Turn ignition switch to OFF.
- 2) Disconnect connector from engine coolant temperature sensor.
- 3) Measure voltage between engine coolant temperature sensor connector and engine ground.

**Connector & terminal**

**(E8) No. 1 (+) — Engine ground (-):**

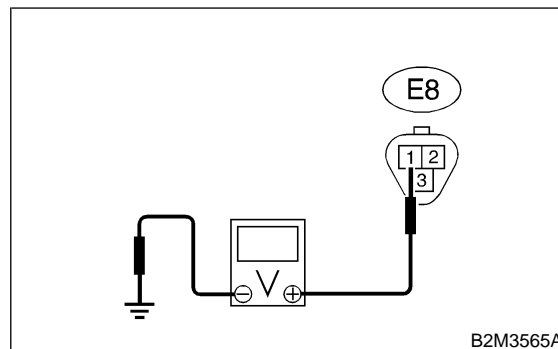

**CHECK** : **Is the voltage more than 10 V?**

**YES** : Repair battery short circuit in harness between ECM and engine coolant temperature sensor connector.

**NO** : Go to step **1013**.

**1013 : CHECK HARNESS BETWEEN ENGINE COOLANT TEMPERATURE SENSOR AND ECM CONNECTOR.**

- 1) Turn ignition switch to ON.
- 2) Measure voltage between engine coolant temperature sensor connector and engine ground.

**Connector & terminal**

**(E8) No. 1 (+) — Engine ground (-):**

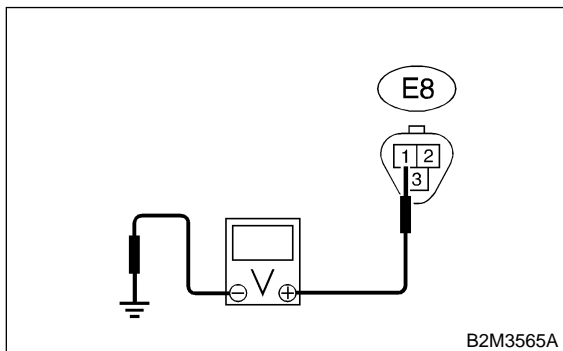

- CHECK** : **Is the voltage more than 10 V?**
- YES** : Repair battery short circuit in harness between ECM and engine coolant temperature sensor connector.
- NO** : Go to step **1014**.

**1014 : CHECK HARNESS BETWEEN ENGINE COOLANT TEMPERATURE SENSOR AND ECM CONNECTOR.**

Measure voltage between engine coolant temperature sensor connector and engine ground.

**Connector & terminal**

**(E8) No. 1 (+) — Engine ground (-):**

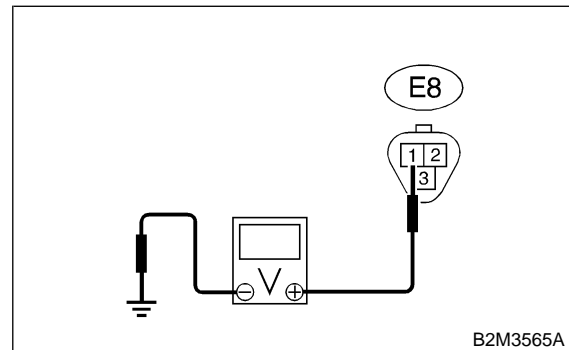

- CHECK** : **Is the voltage more than 4 V?**
- YES** : Go to step **1015**.
- NO** : Repair harness and connector.

**NOTE:**

In this case, repair the following:

- Open circuit in harness between ECM and engine coolant temperature sensor connector
- Poor contact in engine coolant temperature sensor connector
- Poor contact in ECM connector
- Poor contact in coupling connector (B21)
- Poor contact in joint connector (B122)

**1015 : CHECK HARNESS BETWEEN ENGINE COOLANT TEMPERATURE SENSOR AND ECM CONNECTOR.**

- 1) Turn ignition switch to OFF.
- 2) Measure resistance of harness between engine coolant temperature sensor connector and engine ground.

**Connector & terminal**

**(E8) No. 2 — Engine ground:**

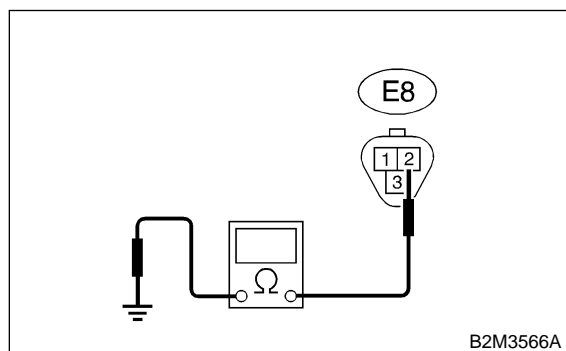

**CHECK** : **Is the resistance less than 5  $\Omega$ ?**

**YES** : Replace engine coolant temperature sensor. <Ref. to 2-7 [W4A0].>

**NO** : Repair harness and connector.

**NOTE:**

In this case, repair the following:

- Open circuit in harness between ECM and engine coolant temperature sensor connector
- Poor contact in engine coolant temperature sensor connector
- Poor contact in ECM connector
- Poor contact in coupling connector (B21)
- Poor contact in joint connector (B122)

**J: DTC P0121 — THROTTLE POSITION SENSOR CIRCUIT RANGE/PERFORMANCE PROBLEM (HIGH INPUT) —**

- **DTC DETECTING CONDITION:**
  - Two consecutive driving cycles with fault
- **TROUBLE SYMPTOM:**
  - Erroneous idling
  - Engine stalls.
  - Poor driving performance

**CAUTION:**

After repair or replacement of faulty parts, conduct CLEAR MEMORY MODE <Ref. to 2-7 [T3D0].> and INSPECTION MODE <Ref. to 2-7 [T3E0].>

● **WIRING DIAGRAM:**

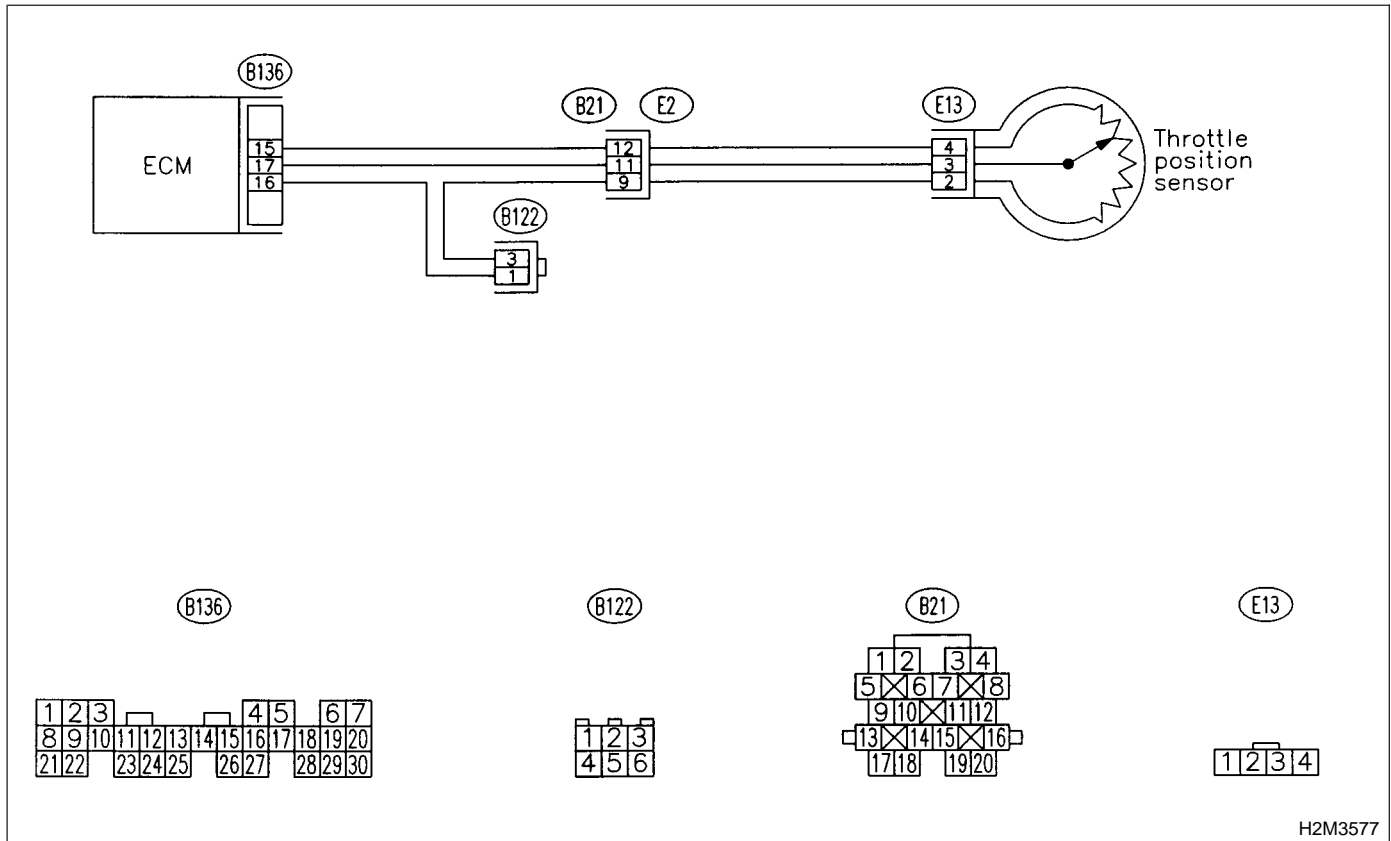

H2M3577

**10J1 : CHECK ANY OTHER DTC ON DISPLAY.**

- CHECK** : Does the Subaru Select Monitor or OBD-II general scan tool indicate DTC P0122 or P0123?
- YES** : Inspect DTC P0122 or P0123 using "10. Diagnostics Chart with Trouble Code". <Ref. to 2-7 [T10A0].>

**NOTE:**

In this case, it is not necessary to inspect DTC P0121.

- NO** : Replace throttle position sensor. <Ref. to 2-7 [W10A0].>

MEMO:



**K: DTC P0122 — THROTTLE POSITION SENSOR CIRCUIT LOW INPUT —**

- **DTC DETECTING CONDITION:**
  - Immediately at fault recognition
- **TROUBLE SYMPTOM:**
  - Erroneous idling
  - Engine stalls.
  - Poor driving performance

**CAUTION:**

After repair or replacement of faulty parts, conduct CLEAR MEMORY MODE <Ref. to 2-7 [T3D0].> and INSPECTION MODE <Ref. to 2-7 [T3E0].>

● **WIRING DIAGRAM:**

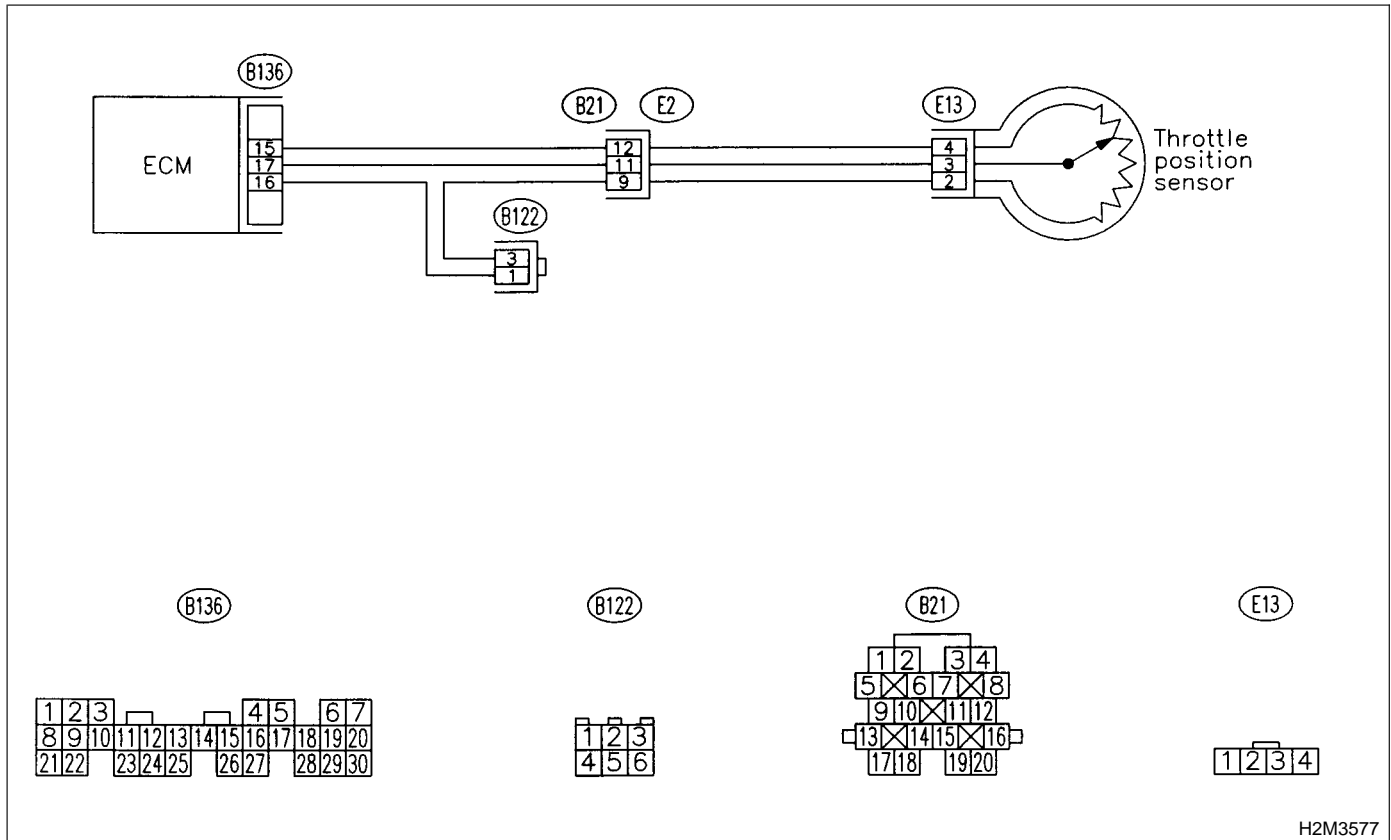

H2M3577

**10K1 : CHECK CURRENT DATA.**

- 1) Start engine.
- 2) Read data of throttle position sensor signal using Subaru Select Monitor or OBD-II general scan tool.

NOTE:

- Subaru Select Monitor  
For detailed operation procedure, refer to the "READ CURRENT DATA SHOWN ON DISPLAY FOR ENGINE". <Ref. to 2-7 [T3C4].>
- OBD-II general scan tool  
For detailed operation procedures, refer to the OBD-II General Scan Tool Instruction Manual.

- CHECK** : *Is the value less than 0.1 V?*
- YES** : Go to step **10K2**.
- NO** : Even if MIL lights up, the circuit has returned to a normal condition at this time. A temporary poor contact of the connector may be the cause.

NOTE:

- In this case, repair the following:
- Poor contact in throttle position sensor connector
  - Poor contact in ECM connector
  - Poor contact in coupling connector (B122)

**10K2 : CHECK INPUT SIGNAL FOR ECM.**

Measure voltage between ECM connector and chassis ground while throttle valve is fully closed.

**Connector & terminal**  
**(B136) No. 15 (+) — Chassis ground (-):**

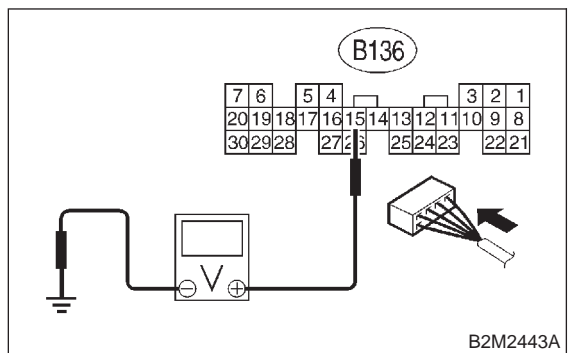

- CHECK** : *Is the voltage more than 4.5 V?*
- YES** : Go to step **10K4**.
- NO** : Go to step **10K3**.

**10K3 : CHECK INPUT SIGNAL FOR ECM.**

Measure voltage between ECM connector and chassis ground.

**Connector & terminal**  
**(B136) No. 15 (+) — Chassis ground (-):**

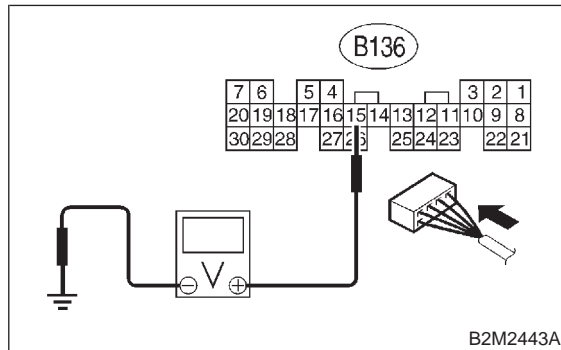

- CHECK** : *Does the voltage change more than 4.5 V by shaking harness and connector of ECM while monitoring the value with voltage meter?*
- YES** : Repair poor contact in ECM connector.
- NO** : Contact with SOA service.

NOTE:

Inspection by DTM is required, because probable cause is deterioration of multiple parts.

**10K4 : CHECK INPUT SIGNAL FOR ECM.**

Measure voltage between ECM connector and chassis ground.

**Connector & terminal**  
**(B136) No. 17 (+) — Chassis ground (-):**

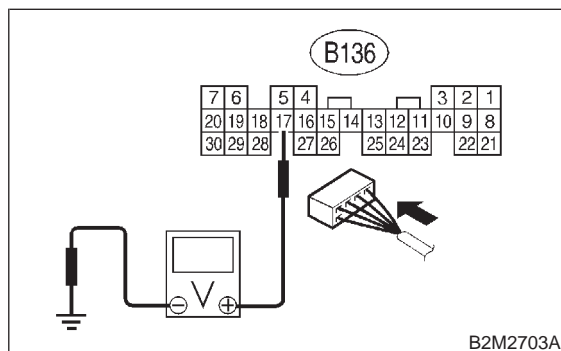

- CHECK** : *Is the voltage less than 0.1 V?*
- YES** : Go to step **10K6**.
- NO** : Go to step **10K5**.

**10K5 : CHECK INPUT SIGNAL FOR ECM.  
(USING SUBARU SELECT MONI-  
TOR.)**

Measure voltage between ECM connector and chassis ground.

**CHECK** : *Does the voltage change more than 0.1 V by shaking harness and connector of ECM while monitoring the value with Subaru Select Monitor?*

**YES** : Repair poor contact in ECM connector.

**NO** : Go to step 10K6.

**10K6 : CHECK HARNESS BETWEEN ECM  
AND THROTTLE POSITION SEN-  
SOR CONNECTOR.**

- 1) Turn ignition switch to OFF.
- 2) Disconnect connectors from throttle position sensor.
- 3) Turn ignition switch to ON.
- 4) Measure voltage between throttle position sensor connector and engine ground.

**Connector & terminal**

**(E13) No. 4 (+) — Engine ground (-):**

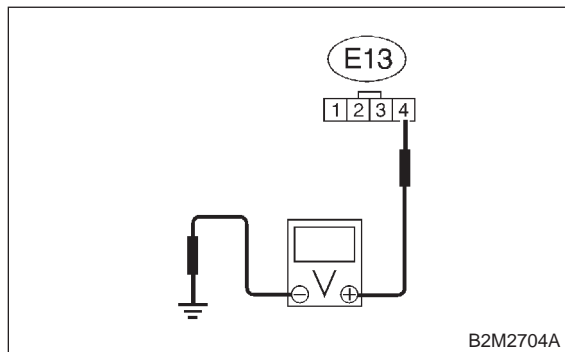

**CHECK** : *Is the voltage more than 4.5 V?*

**YES** : Go to step 10K7.

**NO** : Repair harness and connector.

**NOTE:**

In this case, repair the following:

- Open circuit in harness between throttle position sensor and ECM connector
- Poor contact in throttle position sensor connector
- Poor contact in ECM connector
- Poor contact in coupling connector (B21)
- Poor contact in joint connector (B122)

**10K7 : CHECK HARNESS BETWEEN ECM  
AND THROTTLE POSITION SEN-  
SOR CONNECTOR.**

- 1) Turn ignition switch to OFF.
- 2) Measure resistance of harness between ECM connector and throttle position sensor connector.

**Connector & terminal**

**(B136) No. 17 — (E13) No. 3:**

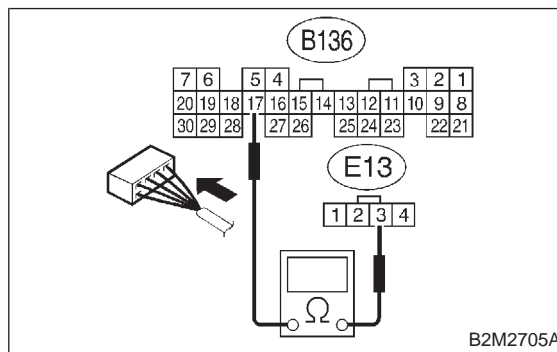

**CHECK** : *Is the resistance less than 1 Ω?*

**YES** : Go to step 10K8.

**NO** : Repair harness and connector.

**NOTE:**

In this case, repair the following:

- Open circuit in harness between throttle position sensor and ECM connector
- Poor contact in ECM connector
- Poor contact in throttle position sensor connector
- Poor contact in coupling connector (B21)

**10K8 : CHECK HARNESS BETWEEN ECM AND THROTTLE POSITION SENSOR CONNECTOR.**

Measure resistance of harness between throttle position sensor connector and engine ground.

**Connector & terminal**

**(E13) No. 3 — Engine ground:**

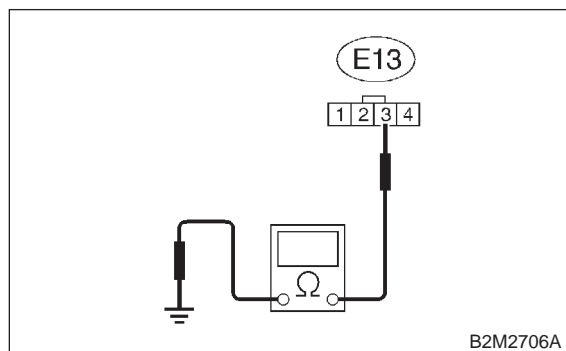

- CHECK** : **Is the resistance less than 10 Ω?**
- YES** : Repair ground short circuit in harness between throttle position sensor and ECM connector.
- NO** : Go to step **10K9**.

**10K9 : CHECK POOR CONTACT.**

Check poor contact in throttle position sensor connector. <Ref. to FOREWORD [T3C1].>

- CHECK** : **Is there poor contact in throttle position sensor connector?**
- YES** : Repair poor contact in throttle position sensor connector.
- NO** : Replace throttle position sensor. <Ref. to 2-7 [W10A0].>

**L: DTC P0123 — THROTTLE POSITION SENSOR CIRCUIT HIGH INPUT —**

- **DTC DETECTING CONDITION:**
  - Immediately at fault recognition
- **TROUBLE SYMPTOM:**
  - Erroneous idling
  - Engine stalls.
  - Poor driving performance

**CAUTION:**

After repair or replacement of faulty parts, conduct CLEAR MEMORY MODE <Ref. to 2-7 [T3D0].> and INSPECTION MODE <Ref. to 2-7 [T3E0].>

● **WIRING DIAGRAM:**

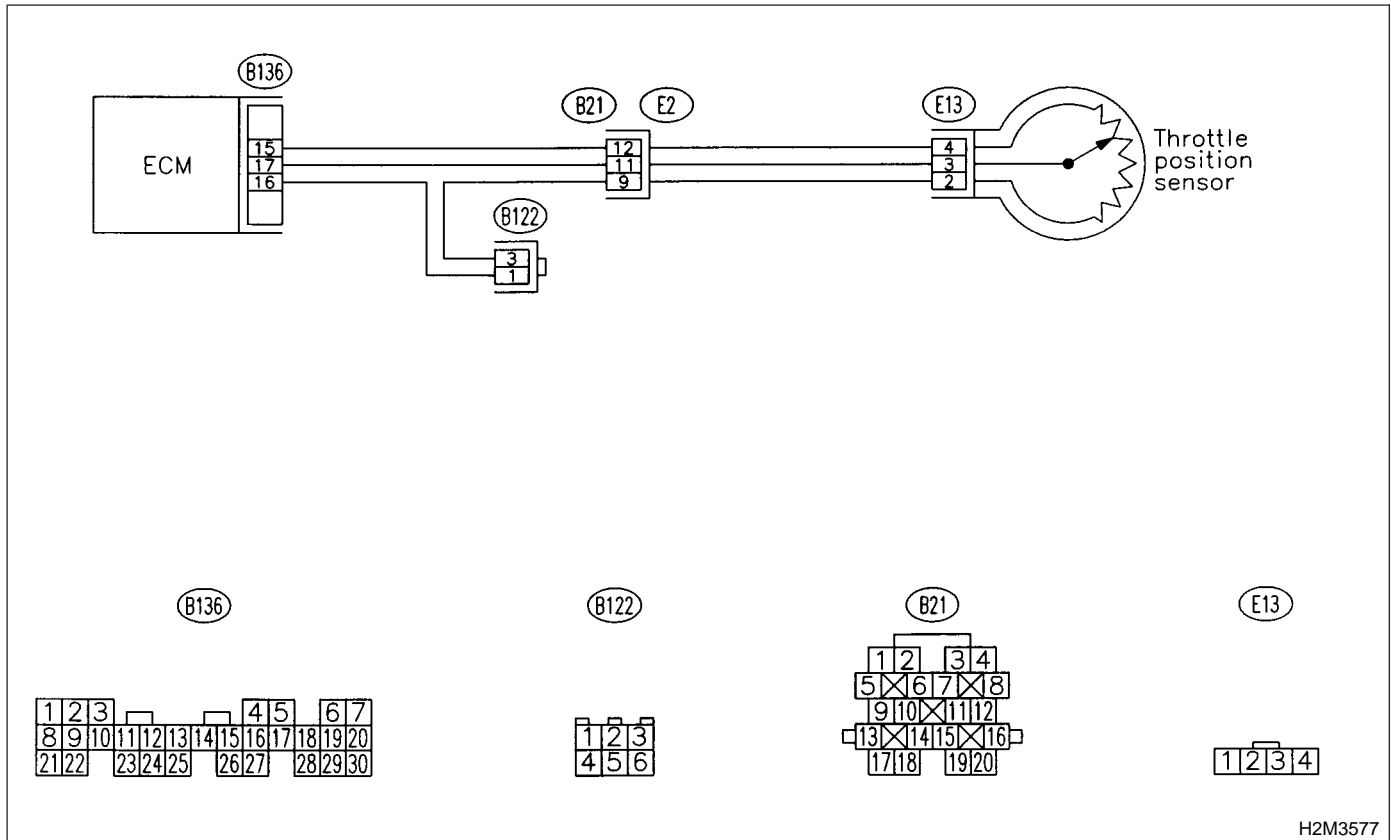

H2M3577

**10L1 : CHECK CURRENT DATA.**

- 1) Start engine.
- 2) Read data of throttle position sensor signal using Subaru Select Monitor or OBD-II general scan tool.

**NOTE:**

- Subaru Select Monitor

For detailed operation procedure, refer to the "READ CURRENT DATA SHOWN ON DISPLAY FOR ENGINE". <Ref. to 2-7 [T3C4].>

- OBD-II general scan tool

For detailed operation procedures, refer to the OBD-II General Scan Tool Instruction Manual.

**CHECK** : *Is the value more than 4.9 V?*

**YES** : Go to step **10L2**.

**NO** : Even if MIL lights up, the circuit has returned to a normal condition at this time. A temporary poor contact of the connector may be the cause.

**NOTE:**

In this case, repair the following:

- Poor contact in throttle position sensor connector
- Poor contact in ECM connector
- Poor contact in coupling connector (B21)

**10L2 : CHECK HARNESS BETWEEN THROTTLE POSITION SENSOR AND ECM CONNECTOR.**

- 1) Turn ignition switch to OFF.
- 2) Disconnect connector from throttle position sensor.
- 3) Measure resistance of harness between throttle position sensor connector and engine ground.

**Connector & terminal**

**(E13) No. 2 — Engine ground:**

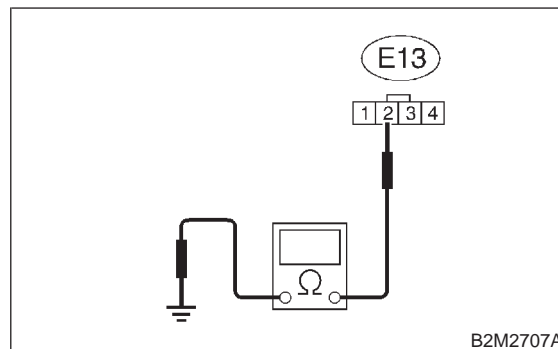

**CHECK** : *Is the resistance less than 5 Ω?*

**YES** : Go to step **10L3**.

**NO** : Repair harness and connector.

**NOTE:**

In this case, repair the following:

- Open circuit in harness between throttle position sensor and ECM connector
- Poor contact in coupling connector (B21)
- Poor contact in joint connector (B122)

**10L3 : CHECK HARNESS BETWEEN THROTTLE POSITION SENSOR AND ECM CONNECTOR.**

- 1) Turn ignition switch to ON.
- 2) Measure voltage between throttle position sensor connector and engine ground.

**Connector & terminal**

**(E13) No. 3 (+) — Engine ground (-):**

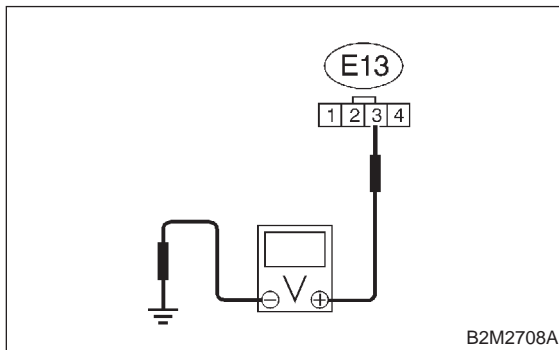

- CHECK** : **Is the voltage more than 4.9 V?**
- YES** : Repair battery short circuit in harness between throttle position sensor and ECM connector. After repair, replace ECM. <Ref. to 2-7 [W17A0].>
- NO** : Replace throttle position sensor. <Ref. to 2-7 [W10A0].>

**M: DTC P0125 — INSUFFICIENT COOLANT TEMPERATURE FOR CLOSED LOOP FUEL CONTROL —**

- **DTC DETECTING CONDITION:**
  - Two consecutive driving cycles with fault
- **TROUBLE SYMPTOM:**
  - Engine would not return to idling.

**CAUTION:**

After repair or replacement of faulty parts, conduct **CLEAR MEMORY MODE** <Ref. to 2-7 [T3D0].> and **INSPECTION MODE** <Ref. to 2-7 [T3E0].>

● **WIRING DIAGRAM:**

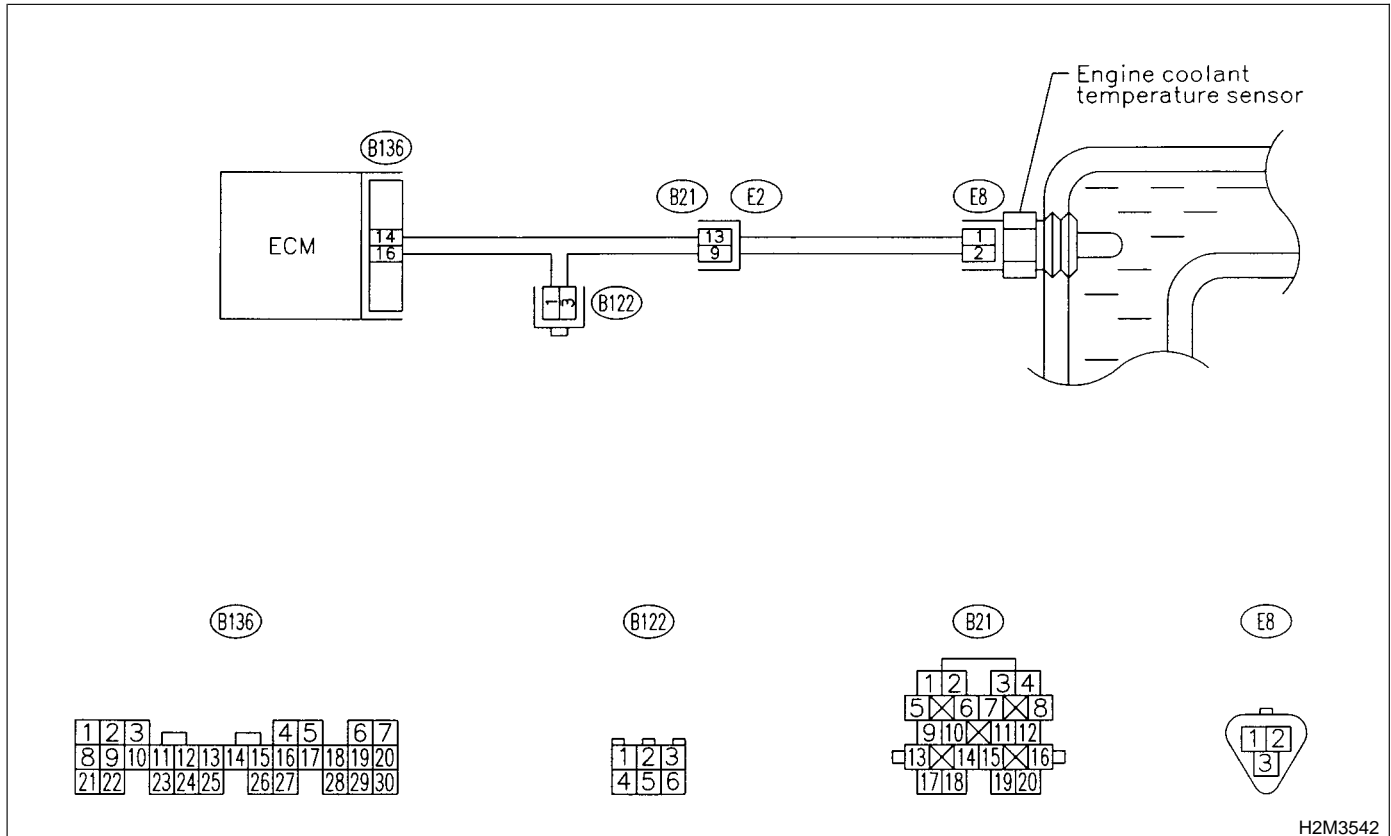

H2M3542

**10M1 : CHECK ANY OTHER DTC ON DISPLAY.**

- CHECK** : Does the Subaru Select Monitor or OBD-II general scan tool indicate DTC P0116 or P0117?
- YES** : Inspect DTC P0116 or P0117 using "10. Diagnostics Chart with Trouble Code". <Ref. to 2-7 [T10A0].>

**NOTE:**

In this case, it is not necessary to inspect DTC P0125.

- NO** : Go to step **10M2**.

**10M2 : CHECK THERMOSTAT.**

- CHECK** : Does thermostat remain opened?
- YES** : Replace thermostat. <Ref. to 2-5 [W2A0].>
- NO** : Replace engine coolant temperature sensor. <Ref. to 2-7 [W4A0].>



**N: DTC P0130 — FRONT OXYGEN (A/F) SENSOR CIRCUIT RANGE/PERFORMANCE PROBLEM —**

- **DTC DETECTING CONDITION:**
  - Two consecutive driving cycles with fault

**CAUTION:**

After repair or replacement of faulty parts, conduct **CLEAR MEMORY MODE** <Ref. to 2-7 [T3D0].> and **INSPECTION MODE** <Ref. to 2-7 [T3E0].>

● **WIRING DIAGRAM:**

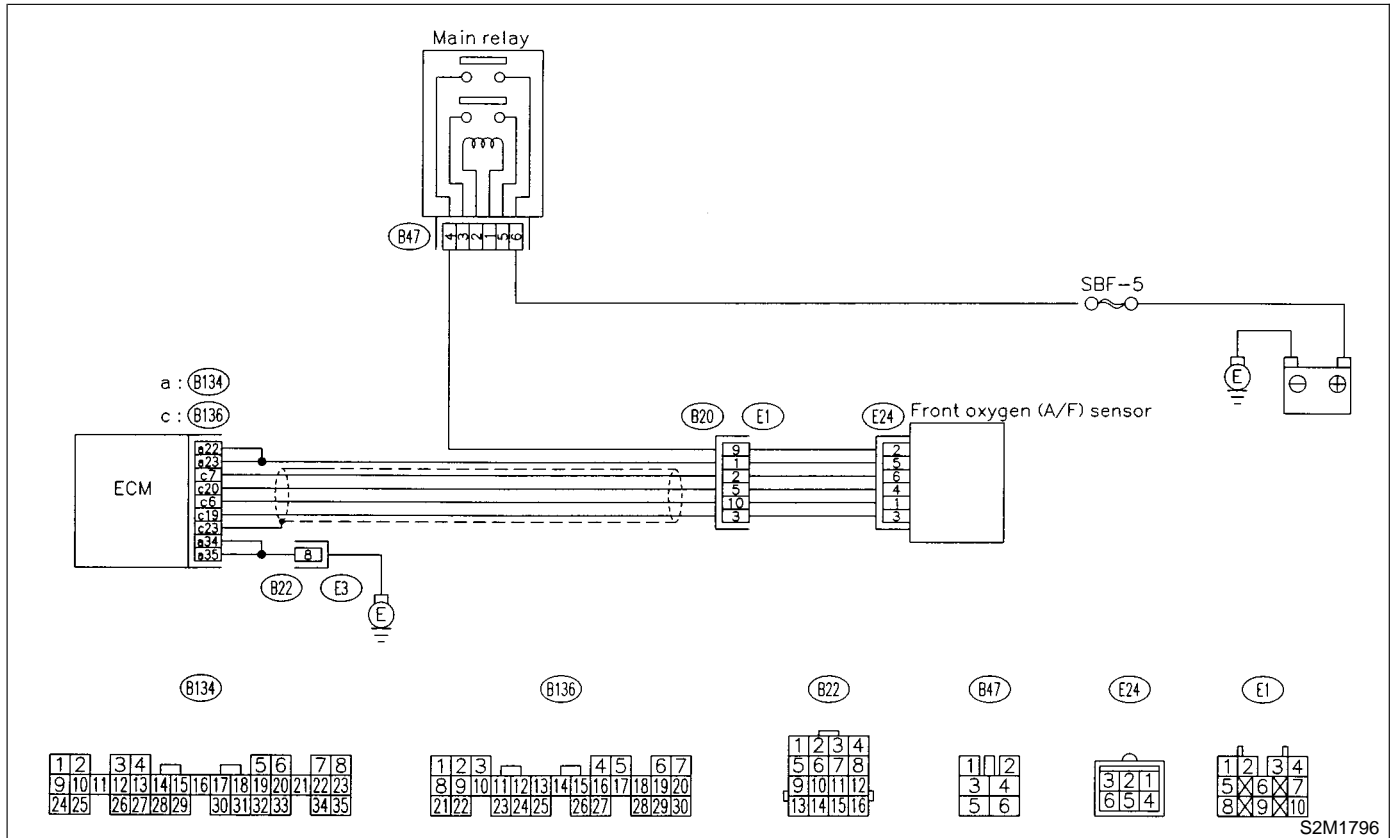

**10N1 : CHECK ANY OTHER DTC ON DISPLAY.**

- CHECK** : Does the Subaru Select Monitor or OBD-II general scan tool indicate DTC P1130, P1131, P1132 or P1133?
- YES** : Inspect DTC P1130, P1131, P1132 or P1133 using "10. Diagnostics Chart with Trouble Code". <Ref. to 2-7 [T10A0].>
- NO** : Go to step **10N2**.

**10N2 : CHECK FRONT OXYGEN (A/F) SENSOR DATA.**

- 1) Start engine.
- 2) While observing the Subaru Select Monitor or OBD-II general scan tool screen, warm-up the engine until coolant temperature is above 70°C (160°F).  
If the engine is already warmed-up, operate at idle speed for at least 1 minute.
- 3) Read data of front oxygen (A/F) sensor signal using Subaru Select Monitor or OBD-II general scan tool.

**NOTE:**

- Subaru Select Monitor

For detailed operation procedure, refer to the "READ CURRENT DATA SHOWN ON DISPLAY FOR ENGINE". <Ref. to 2-7 [T3C4].>

- OBD-II general scan tool

For detailed operation procedures, refer to the OBD-II General Scan Tool Instruction Manual.

**CHECK** : *Is the value equal to or more than 0.85 and equal to less than 1.15 in idling?*

**YES** : Go to step **10N3**.

**NO** : Go to step **10N4**.

**10N3 : CHECK FRONT OXYGEN (A/F) SENSOR DATA.**

Race engine at speeds from idling to 5,000 rpm for a total of 5 cycles.

**NOTE:**

To increase engine speed to 5,000 rpm, slowly depress accelerator pedal, taking approximately 5 seconds, and quickly release accelerator pedal to decrease engine speed.

**CHECK** : *Is the value more than 1.1 for a moment?*

**YES** : Go to step **10N6**.

**NO** : Go to step **10N4**.

**10N4 : CHECK HARNESS BETWEEN ECM AND FRONT OXYGEN (A/F) SENSOR.**

- 1) Turn ignition switch to OFF.
- 2) Disconnect connector from ECM and front oxygen (A/F) sensor connector.
- 3) Measure resistance between ECM and front oxygen (A/F) sensor.

**Connector & terminals**

**(B136) No. 6 — (E24) No. 1:**

**(B136) No. 7 — (E24) No. 6:**

**(B136) No. 19 — (E24) No. 3:**

**(B136) No. 20 — (E24) No. 4:**

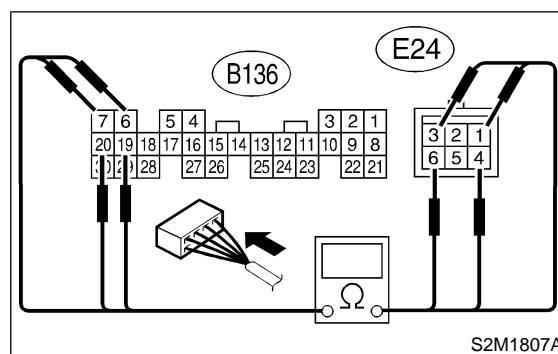

**CHECK** : *Is the resistance less than 5 Ω?*

**YES** : Go to step **10N5**.

**NO** : Repair open circuit between ECM and front oxygen (A/F) sensor.

**10N5 : CHECK HARNESS BETWEEN ECM AND FRONT OXYGEN (A/F) SENSOR.**

Measure resistance between ECM and chassis ground.

**Connector & terminals**

**(B136) No. 6 — Chassis ground:**

**(B136) No. 7 — Chassis ground:**

**(B136) No. 19 — Chassis ground:**

**(B136) No. 20 — Chassis ground:**

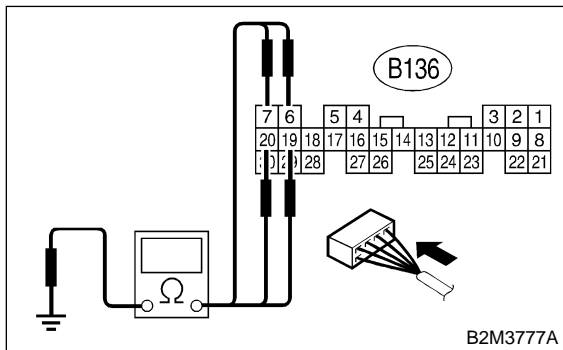

**CHECK** : **Is the resistance more than 1 MΩ?**

**YES** : Go to step **10N6**.

**NO** : Repair ground short circuit between ECM and front oxygen (A/F) sensor.

**10N6 : CHECK EXHAUST SYSTEM.**

Check exhaust system parts.

**NOTE:**

Check the following items.

- Loose installation of portions
- Damage (crack, hole etc.) of parts
- Looseness of front oxygen (A/F) sensor
- Looseness and ill fitting of parts between front oxygen (A/F) sensor and rear oxygen sensor

**CHECK** : **Is there a fault in exhaust system?**

**YES** : Repair or replace faulty parts.

**NO** : Replace front oxygen (A/F) sensor.  
<Ref. to 2-7 [W8A0].>

**O: DTC P0133 — FRONT OXYGEN (A/F) SENSOR CIRCUIT SLOW RESPONSE —**

**• DTC DETECTING CONDITION:**

- Two consecutive driving cycles with fault

**CAUTION:**

After repair or replacement of faulty parts, conduct CLEAR MEMORY MODE <Ref. to 2-7 [T3D0].> and INSPECTION MODE <Ref. to 2-7 [T3E0].>

**• WIRING DIAGRAM:**

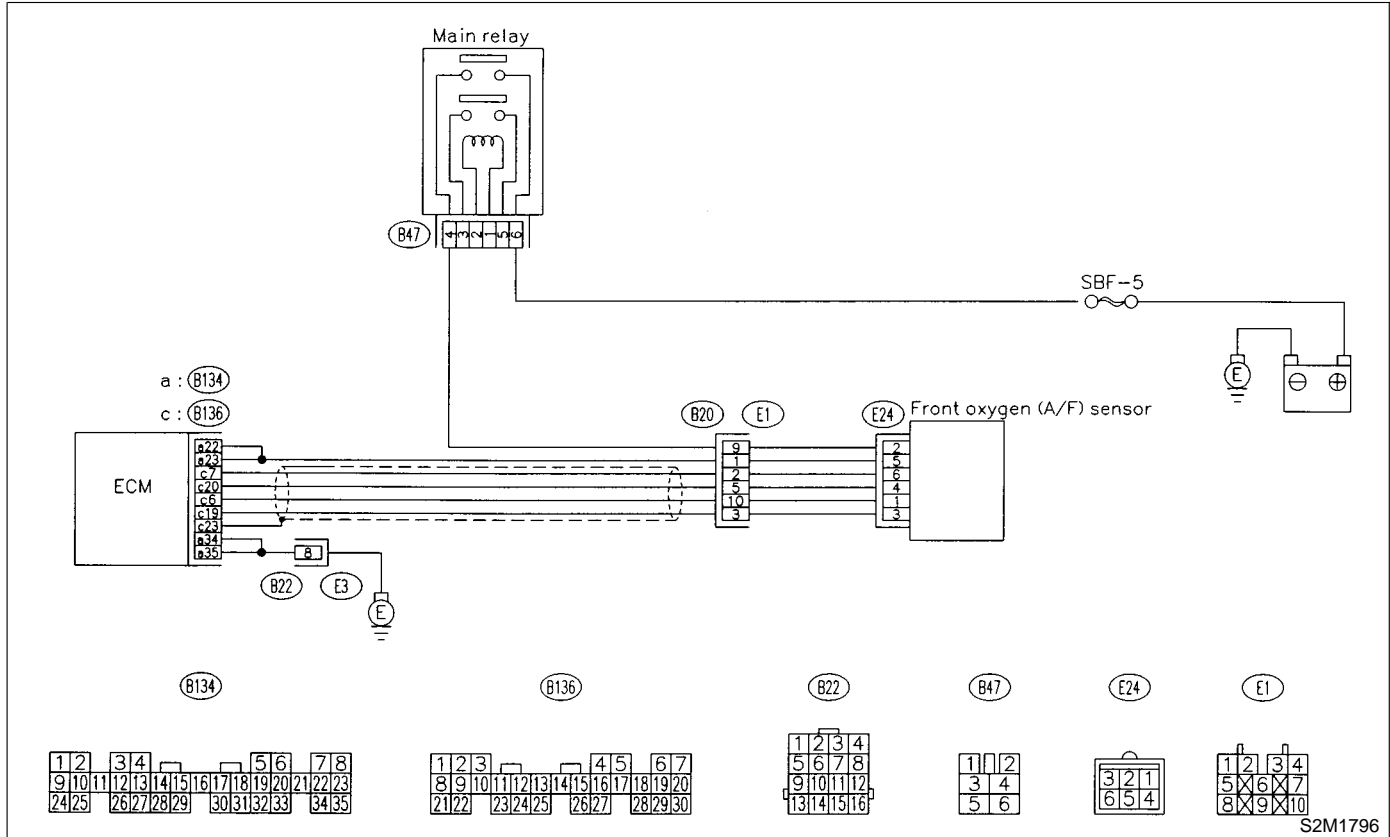

**1001 : CHECK ANY OTHER DTC ON DISPLAY.**

**CHECK** : Does the Subaru Select Monitor or OBD-II general scan tool indicate DTC P1130, P1131, P1132 or P1133?

**YES** : Inspect DTC P1130, P1131, P1132 or P1133 using "10. Diagnostics Chart with Trouble Code". <Ref. to 2-7 [T10A0].>

**NOTE:**  
In this case, it is not necessary to inspect DTC P0133.

**NO** : Go to step **1002**.

**1002 : CHECK EXHAUST SYSTEM.**

**NOTE:**

- Check the following items.
- Loose installation of front portion of exhaust pipe onto cylinder heads
  - Loose connection between front exhaust pipe and front catalytic converter
  - Damage of exhaust pipe resulting in a hole

**CHECK** : Is there a fault in exhaust system?

**YES** : Repair exhaust system.

**NO** : Replace front oxygen (A/F) sensor. <Ref. to 2-7 [W8A0].>

**P: DTC P0136 — REAR OXYGEN SENSOR CIRCUIT MALFUNCTION —**

**• DTC DETECTING CONDITION:**

- Two consecutive driving cycles with fault

**CAUTION:**

After repair or replacement of faulty parts, conduct CLEAR MEMORY MODE <Ref. to 2-7 [T3D0].> and INSPECTION MODE <Ref. to 2-7 [T3E0].>

**• WIRING DIAGRAM:**

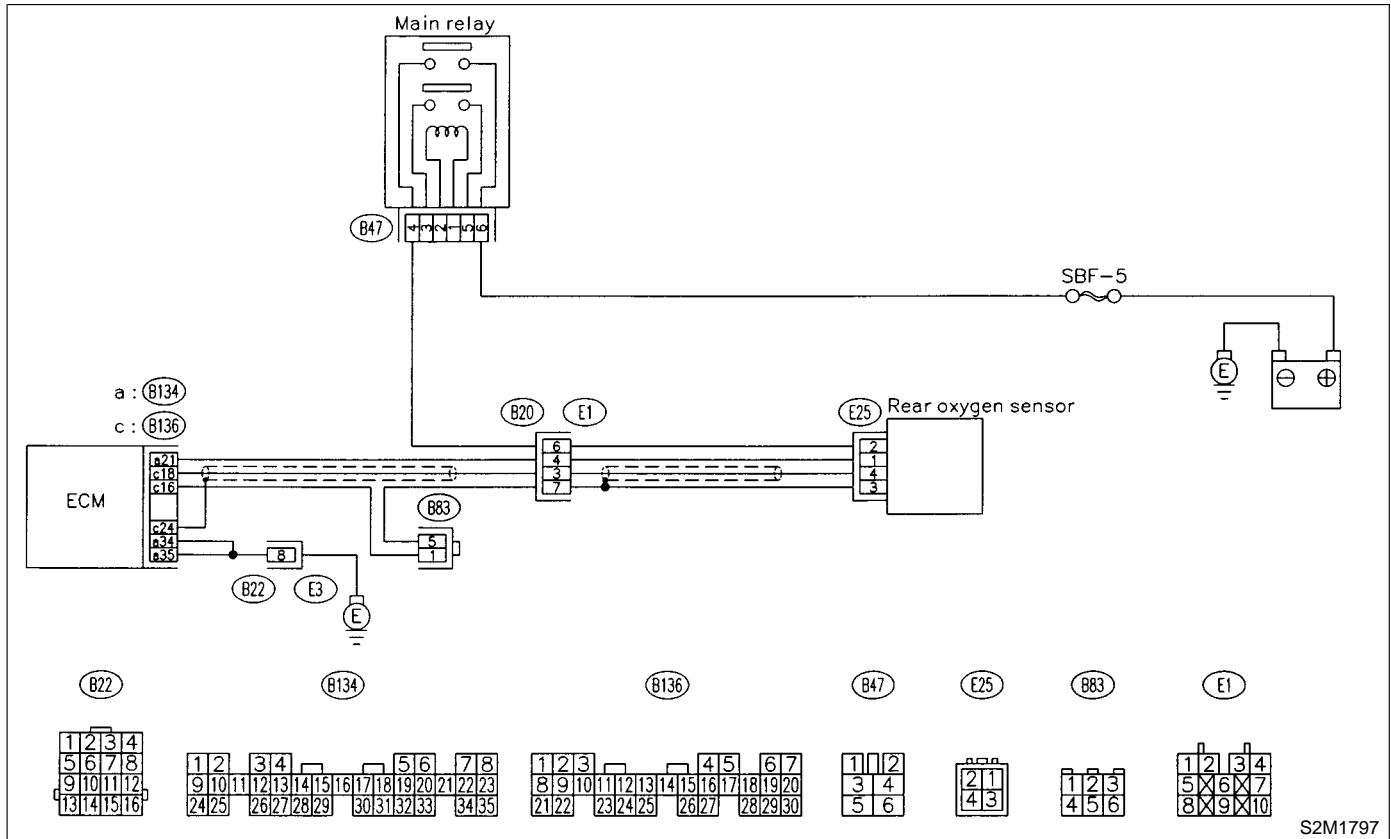

S2M1797

**10P1 : CHECK ANY OTHER DTC ON DISPLAY.**

- CHECK** : Does the Subaru Select Monitor or OBD-II general scan tool indicate DTC P1130 or P1131?
- YES** : Go to step 10P2.
- NO** : Go to step 10P3.

**10P2 : CHECK FAILURE CAUSE OF P0130.**

Inspect DTC P1130 or P1131 using "10. Diagnostics Chart with Trouble Code". <Ref. to 2-7 [T10A0].>

- CHECK** : Is the failure cause of P1130 or P1131 in the fuel system?
- YES** : Check fuel system.

**NOTE:**

In this case, it is not necessary to inspect DTC P0136.

- NO** : Go to step 10P3.



**10P6 : CHECK HARNESS BETWEEN REAR OXYGEN SENSOR AND ECM CONNECTOR.**

- 1) Turn ignition switch to OFF.
- 2) Disconnect connector from rear oxygen sensor.
- 3) Turn ignition switch to ON.
- 4) Measure voltage between rear oxygen sensor harness connector and engine ground or chassis ground.

**Connector & terminal**

**(E24) No. 4 (+) — Engine ground (-):**

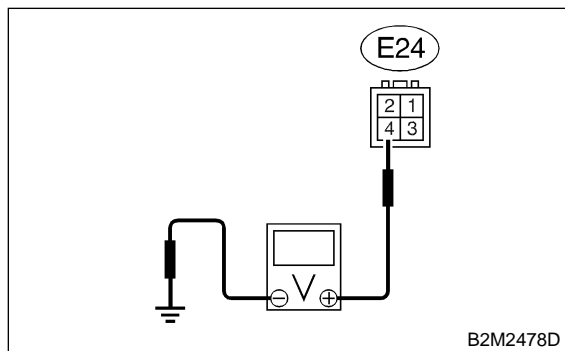

- CHECK** : **Is the voltage more than 0.2 V?**
- YES** : Replace rear oxygen sensor. <Ref. to 2-7 [W9A0].>
- NO** : Repair harness and connector.

**NOTE:**

In this case, repair the following:

- Open circuit in harness between rear oxygen sensor and ECM connector
- Poor contact in rear oxygen sensor connector
- Poor contact in ECM connector

**10P7 : CHECK EXHAUST SYSTEM.**

Check exhaust system parts.

**NOTE:**

Check the following items.

- Loose installation of portions
- Damage (crack, hole etc.) of parts
- Looseness and ill fitting of parts between front oxygen (A/F) sensor and rear oxygen sensor

- CHECK** : **Is there a fault in exhaust system?**
- YES** : Repair or replace faulty parts.
- NO** : Replace rear oxygen sensor. <Ref. to 2-7 [W9A0].>

**Q: DTC P0139 — REAR OXYGEN SENSOR CIRCUIT SLOW RESPONSE —**

**• DTC DETECTING CONDITION:**

- Two consecutive driving cycles with fault

**CAUTION:**

After repair or replacement of faulty parts, conduct CLEAR MEMORY MODE <Ref. to 2-7 [T3D0].> and INSPECTION MODE <Ref. to 2-7 [T3E0].>

**• WIRING DIAGRAM:**

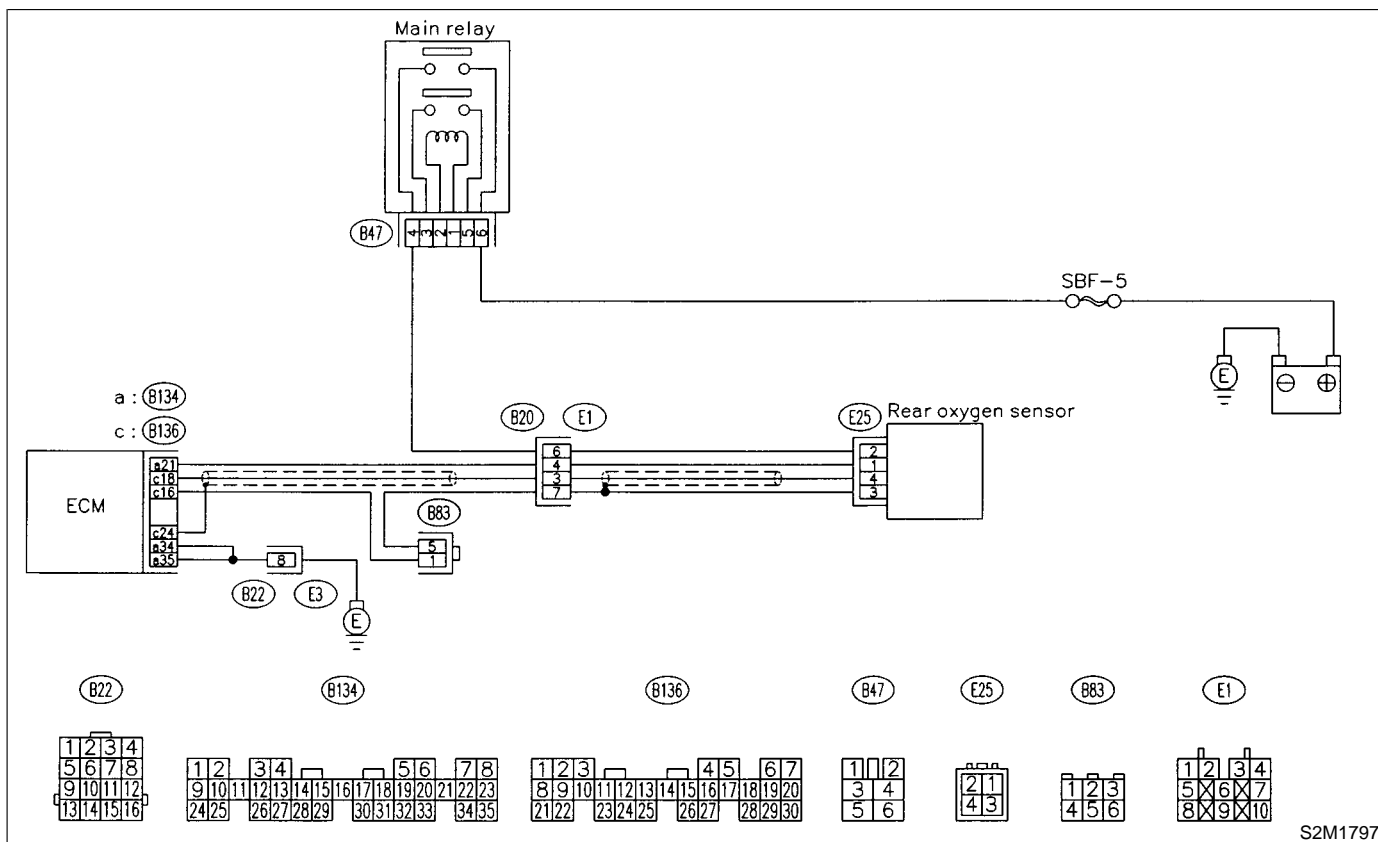

**10Q1 : CHECK ANY OTHER DTC ON DISPLAY.**

**CHECK :** Does the Subaru Select Monitor or OBD-II general scan tool indicate DTC P0136?

**YES :** Inspect DTC P0136 using "10. Diagnostics Chart with Trouble Code". <Ref. to 2-7 [T10A0].>

**NOTE:**  
In this case, it is not necessary to inspect DTC P0139.

**NO :** Replace rear oxygen sensor. <Ref. to 2-7 [W9A0].>



**R: DTC P0141 — REAR OXYGEN SENSOR HEATER CIRCUIT MALFUNCTION**

**• DTC DETECTING CONDITION:**

- Two consecutive driving cycles with fault

**CAUTION:**

After repair or replacement of faulty parts, conduct CLEAR MEMORY MODE <Ref. to 2-7 [T3D0].> and INSPECTION MODE <Ref. to 2-7 [T3E0].>

**• WIRING DIAGRAM:**

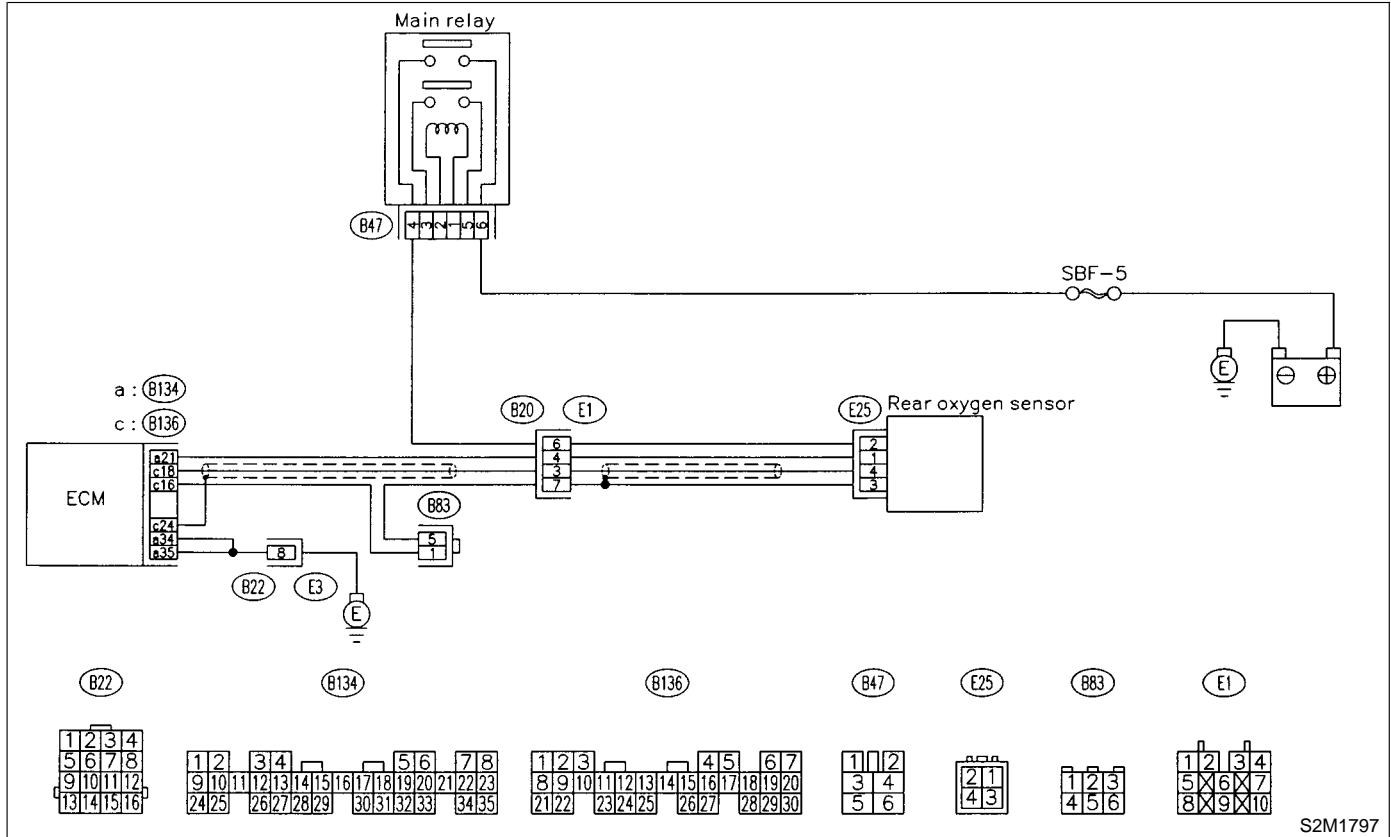

S2M1797

**10R1 : CHECK GROUND CIRCUIT OF ECM.**

- 1) Turn ignition switch to OFF.
- 2) Disconnect connector from ECM.
- 3) Measure resistance of harness between ECM connector and chassis ground.

**Connector & terminal**

**(B134) No. 35 — Chassis ground:**

**(B134) No. 34 — Chassis ground:**

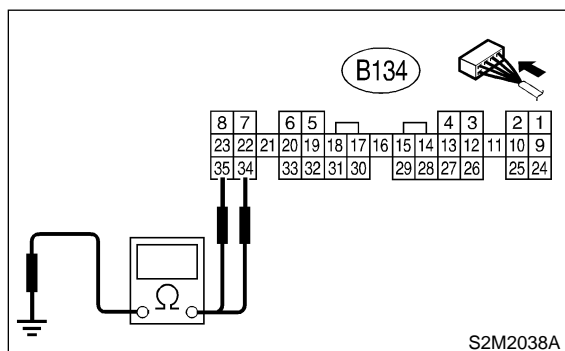

**CHECK** : *Is the resistance less than 5 Ω?*

**YES** : Go to step 10R2.

**NO** : Repair harness and connector.

**NOTE:**

In this case, repair the following:

- Open circuit in harness between ECM and engine ground terminal
- Poor contact in ECM connector
- Poor contact in coupling connector (B22)

**10R2 : CHECK CURRENT DATA.**

- 1) Start engine.
- 2) Read data of rear oxygen sensor heater current using Subaru Select Monitor or OBD-II general scan tool.

**NOTE:**

- Subaru Select Monitor

For detailed operation procedure, refer to the "READ CURRENT DATA SHOWN ON DISPLAY FOR ENGINE". <Ref. to 2-7 [T3C4].>

- OBD-II scan tool

For detailed operation procedures, refer to the OBD-II General Scan Tool Instruction Manual.

**CHECK** : *Is the value more than 0.2 A?*

**YES** : Repair connector.

**NOTE:**

In this case, repair the following:

- Poor contact in rear oxygen sensor connector
- Poor contact in rear oxygen sensor connecting harness connector
- Poor contact in ECM connector

**NO** : Go to step 10R3.

**10R3 : CHECK OUTPUT SIGNAL FROM ECM.**

- 1) Start and idle the engine.
- 2) Measure voltage between ECM connector and chassis ground.

**Connector & terminal**

**(B134) No. 21 (+) — Chassis ground (-):**

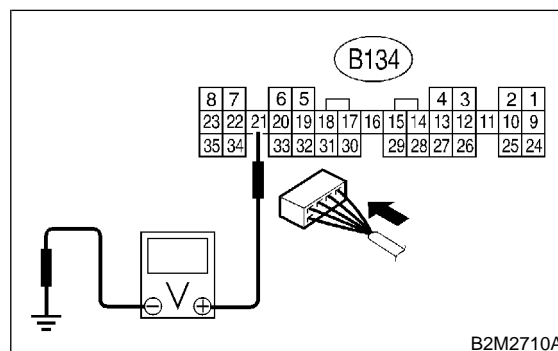

**CHECK** : *Is the voltage less than 1.0 V?*

**YES** : Go to step 10R6.

**NO** : Go to step 10R4.

**10R4 : CHECK OUTPUT SIGNAL FROM ECM.**

Measure voltage between ECM connector and chassis ground.

**Connector & terminal**

**(B134) No. 21 (+) — Chassis ground (-):**

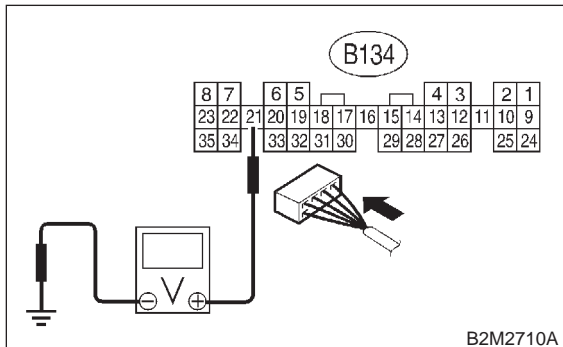

**CHECK** : Does the voltage change less than 1.0 V by shaking harness and connector of ECM while monitoring the value with voltage meter?

**YES** : Repair poor contact in ECM connector.

**NO** : Go to step 10R5.

**10R5 : CHECK OUTPUT SIGNAL FROM ECM.**

1) Disconnect connector from rear oxygen sensor.  
2) Measure voltage between ECM connector and chassis ground.

**Connector & terminal**

**(B134) No. 21 (+) — Chassis ground (-):**

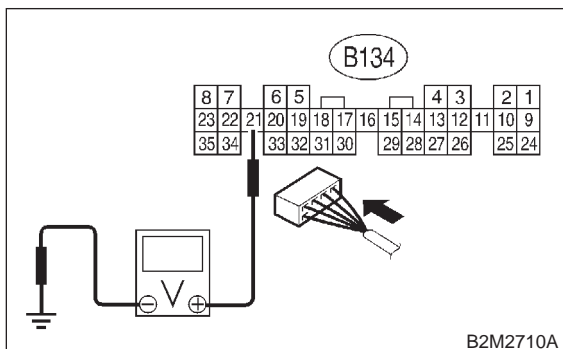

**CHECK** : Is the voltage less than 1.0 V?

**YES** : Replace ECM. <Ref. to 2-7 [W17A0].>

**NO** : Repair battery short circuit in harness between ECM and rear oxygen sensor connector. After repair, replace ECM. <Ref. to 2-7 [W17A0].>

**10R6 : CHECK MAIN RELAY.**

- 1) Turn the ignition switch to OFF.
- 2) Remove main relay.
- 3) Connect battery to main relay terminals No. 1 and No. 2.
- 4) Measure resistance between main relay terminals.

**Terminals**

**No. 4 — No. 6:**

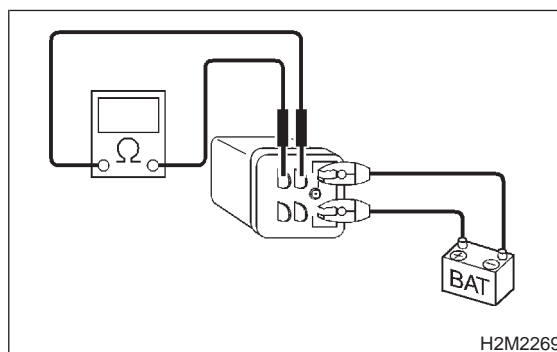

**CHECK** : Is the resistance less than 10 Ω?

**YES** : Go to step 10R7.

**NO** : Replace main relay.

**10R7 : CHECK POWER SUPPLY TO REAR OXYGEN SENSOR.**

- 1) Turn ignition switch to OFF.
- 2) Disconnect connector from rear oxygen sensor.
- 3) Turn ignition switch to ON.
- 4) Measure voltage between rear oxygen sensor connector and engine ground or chassis ground.

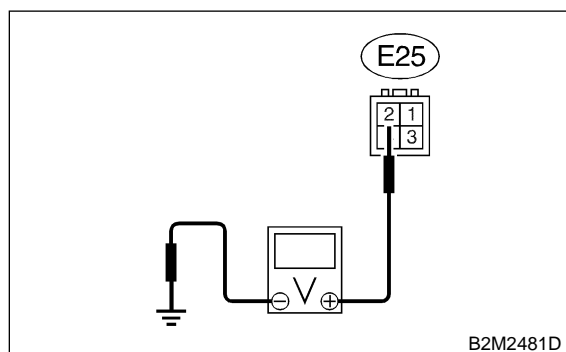
**Connector & terminal****(E25) No. 2 (+) — Chassis ground (-):****CHECK** : **Is the voltage more than 10 V?****YES** : Go to step **10R8**.**NO** : Repair power supply line.**NOTE:**

In this case, repair the following:

- Open circuit in harness between battery and rear oxygen sensor connector
- Poor contact in rear oxygen sensor connector
- Poor contact in coupling connector (E1)

**10R8 : CHECK REAR OXYGEN SENSOR.**

- 1) Turn ignition switch to OFF.
- 2) Measure resistance between rear oxygen sensor connector terminals.

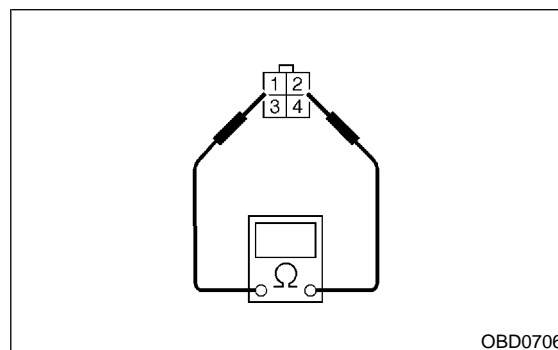
**Terminals****No. 1 — No. 2:****CHECK** : **Is the resistance less than 30 Ω?****YES** : Repair harness and connector.**NOTE:**

In this case, repair the following:

- Open circuit in harness between rear oxygen sensor and ECM connector
- Poor contact in rear oxygen sensor connector
- Poor contact in ECM connector
- Poor contact in coupling connector (E1)

**NO** : Replace rear oxygen sensor. <Ref. to 2-7 [W9A0].>

**S: DTC P0170 — FUEL TRIM MALFUNCTION —****● DTC DETECTING CONDITION:**

- Two consecutive driving cycles with fault

**● TROUBLE SYMPTOM:**

- Erroneous idling
- Engine stalls.
- Poor driving performance

**CAUTION:**

After repair or replacement of faulty parts, conduct **CLEAR MEMORY MODE** <Ref. to 2-7 [T3D0].> and **INSPECTION MODE** <Ref. to 2-7 [T3E0].>.

**10S1 : CHECK EXHAUST SYSTEM.**

**CHECK** : *Are there holes or loose bolts on exhaust system?*

**YES** : Repair exhaust system.

**NO** : Go to step **10S2**.

**10S2 : CHECK AIR INTAKE SYSTEM.**

**CHECK** : *Are there holes, loose bolts or disconnection of hose on air intake system?*

**YES** : Repair air intake system.

**NO** : Go to step **10S3**.

**10S3 : CHECK FUEL PRESSURE.****WARNING:**

- Place “NO FIRE” signs near the working area.
- Be careful not to spill fuel on the floor.

1) Release fuel pressure.

(1) Disconnect connector from fuel pump relay.

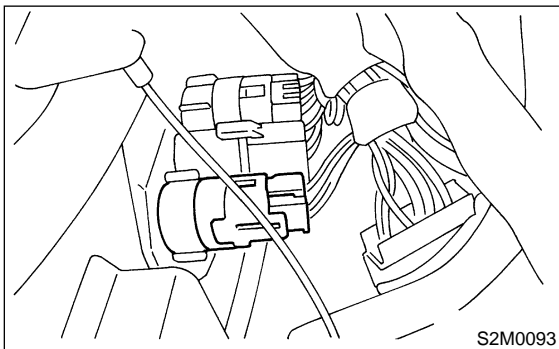

- (2) Start the engine and run it until it stalls.  
 (3) After the engine stalls, crank it for five more seconds.  
 (4) Turn ignition switch to OFF.  
 2) Connect connector to fuel pump relay.  
 3) Disconnect fuel delivery hose from fuel filter, and connect fuel pressure gauge.

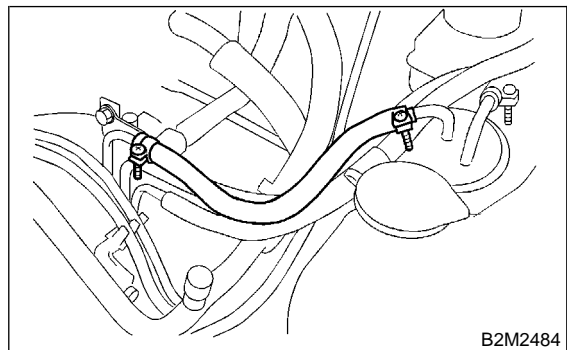

- 4) Install fuel filler cap.
- 5) Start the engine and idle while gear position is neutral.
- 6) Measure fuel pressure while disconnecting pressure regulator vacuum hose from intake manifold.

**WARNING:**  
**Before removing fuel pressure gauge, release fuel pressure.**

**NOTE:**  
 If fuel pressure does not increase, squeeze fuel return hose 2 to 3 times, then measure fuel pressure again.

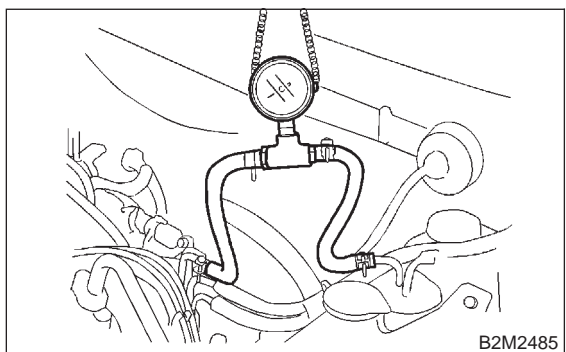

**CHECK** : **Is fuel pressure between 284 and 314 kPa (2.9 — 3.2 kg/cm<sup>2</sup>, 41 — 46 psi)?**

- YES** : Go to step 10S4.
- NO** : Repair the following items.

Fuel pressure too high	<ul style="list-style-type: none"> <li>● Clogged fuel return line or bent hose</li> </ul>
Fuel pressure too low	<ul style="list-style-type: none"> <li>● Improper fuel pump discharge</li> <li>● Clogged fuel supply line</li> </ul>

**10S4 : CHECK FUEL PRESSURE.**

After connecting pressure regulator vacuum hose, measure fuel pressure.

**WARNING:**  
**Before removing fuel pressure gauge, release fuel pressure.**

**NOTE:**

- If fuel pressure does not increase, squeeze fuel return hose 2 to 3 times, then measure fuel pressure again.
- If out of specification as measured at this step, check or replace pressure regulator and pressure regulator vacuum hose.

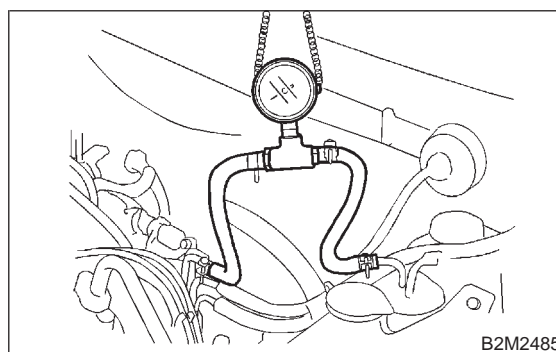

**CHECK** : **Is fuel pressure between 206 and 235 kPa (2.1 — 2.4 kg/cm<sup>2</sup>, 30 — 34 psi)?**

- YES** : Go to step 10S5.
- NO** : Repair the following items.

Fuel pressure too high	<ul style="list-style-type: none"> <li>● Faulty pressure regulator</li> <li>● Clogged fuel return line or bent hose</li> </ul>
Fuel pressure too low	<ul style="list-style-type: none"> <li>● Faulty pressure regulator</li> <li>● Improper fuel pump discharge</li> <li>● Clogged fuel supply line</li> </ul>

**10S5 : CHECK ENGINE COOLANT TEMPERATURE SENSOR.**

- 1) Start the engine and warm-up completely.
- 2) Read data of engine coolant temperature sensor signal using Subaru Select Monitor or OBD-II general scan tool.

**NOTE:**

- Subaru Select Monitor

For detailed operation procedure, refer to the "READ CURRENT DATA SHOWN ON DISPLAY FOR ENGINE". <Ref. to 2-7 [T3C4].>

- OBD-II general scan tool

For detailed operation procedures, refer to the OBD-II General Scan Tool Instruction Manual.

**CHECK** : ***Is temperature between 70°C (158°F) and 100°C (212°F)?***

**YES** : Go to step **10S6**.

**NO** : Replace engine coolant temperature sensor. <Ref. to 2-7 [W4A0].>

**10S6 : CHECK INTAKE MANIFOLD PRESSURE SENSOR SIGNAL.**

- 1) Start the engine and warm-up engine until coolant temperature is greater than 60°C (140°F).
- 2) Place the select lever in "N" or "P" position.
- 3) Turn A/C switch to OFF.
- 4) Turn all accessory switches to OFF.
- 5) Read data of intake manifold pressure sensor signal using Subaru Select Monitor or OBD-II general scan tool.

**NOTE:**

- Subaru Select Monitor

For detailed operation procedure, refer to the "READ CURRENT DATA SHOWN ON DISPLAY FOR ENGINE". <Ref. to 2-7 [T3C4].>

- OBD-II general scan tool

For detailed operation procedures, refer to the OBD-II General Scan Tool Instruction Manual.

**Specification:**

Engine speed	Specified value
Idling	24.0 — 41.3 kPa (180 — 310 mmHg, 7.09 — 41.3 inHg)
Ignition ON	73.3 — 106.6 kPa (550 — 800 mmHg, 21.65 — 31.50 inHg)

**CHECK** : ***Is the voltage within the specifications?***

**YES** : Contact with SOA service.

**NOTE:**

Inspection by DTM is required, because probable cause is deterioration of multiple parts.

**NO** : Replace intake air temperature and pressure sensor. <Ref. to 2-7 [W11A0].>

**T: DTC P0181 — FUEL TEMPERATURE SENSOR A CIRCUIT RANGE/PERFORMANCE PROBLEM —**

- **DTC DETECTING CONDITION:**
  - Two consecutive driving cycles with fault

**CAUTION:**

After repair or replacement of faulty parts, conduct CLEAR MEMORY MODE <Ref. to 2-7 [T3D0].> and INSPECTION MODE <Ref. to 2-7 [T3E0].>

● **WIRING DIAGRAM:**

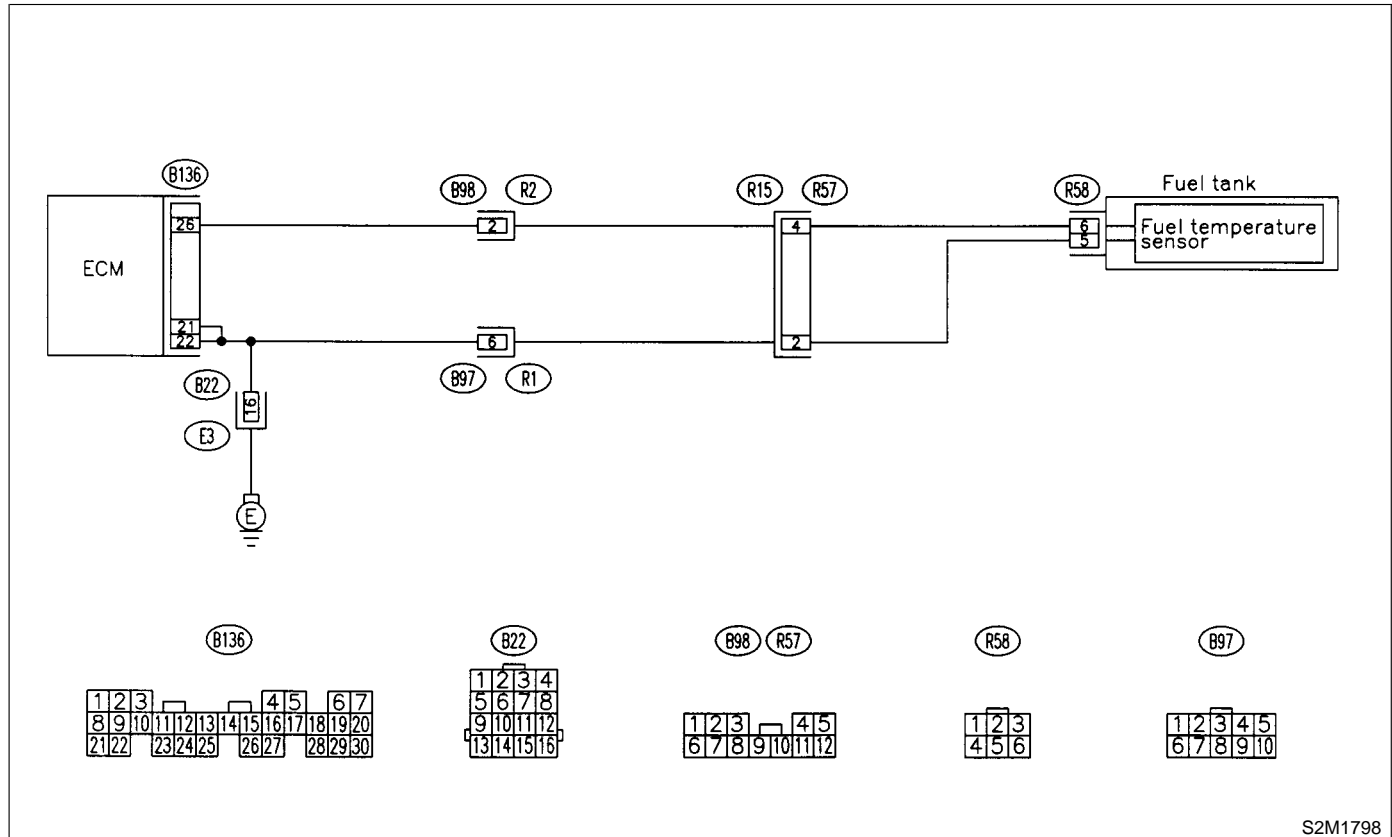

S2M1798

**10T1 : CHECK ANY OTHER DTC ON DISPLAY.**

**CHECK** : Does the Subaru Select Monitor or OBD-II general scan tool indicate DTC P0182 or P0183?

**YES** : Inspect DTC P0182 or P0183 using "10. Diagnostics Chart with Trouble Code". <Ref. to 2-7 [T10A0].>

**NOTE:**  
In this case, it is not necessary to inspect DTC P0181.

**NO** : Replace fuel temperature sensor. <Ref. to 2-1 [W6A0].>



**U: DTC P0182 — FUEL TEMPERATURE SENSOR A CIRCUIT LOW INPUT —**

**● DTC DETECTING CONDITION:**

- Immediately at fault recognition

**CAUTION:**

After repair or replacement of faulty parts, conduct CLEAR MEMORY MODE <Ref. to 2-7 [T3D0].> and INSPECTION MODE <Ref. to 2-7 [T3E0].>

**● WIRING DIAGRAM:**

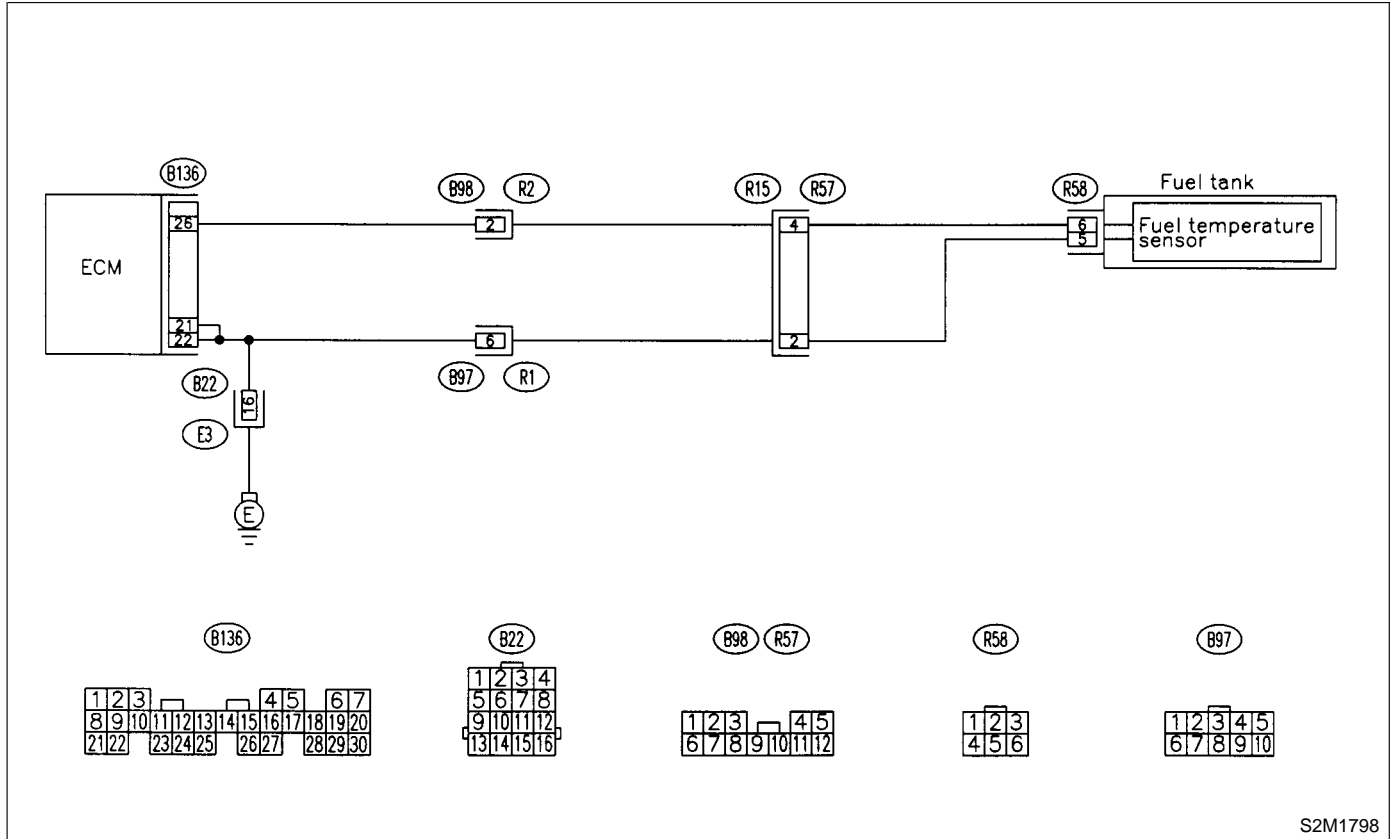

S2M1798

**10U1 : CHECK CURRENT DATA.**

- 1) Start engine.
- 2) Read data of fuel temperature sensor signal using Subaru Select Monitor or OBD-II general scan tool.

**NOTE:**

- Subaru Select Monitor

For detailed operation procedure, refer to the "READ CURRENT DATA SHOWN ON DISPLAY FOR ENGINE". <Ref. to 2-7 [T3C4].>

- OBD-II general scan tool

For detailed operation procedures, refer to the OBD-II General Scan Tool Instruction Manual.

**CHECK** : **Is the value greater than 150°C (302°F)?**

**YES** : Go to step **10U2**.

**NO** : Even if MIL lights up, the circuit has returned to a normal condition at this time.

**10U2 : CHECK CURRENT DATA.**

- 1) Turn ignition switch to OFF.
- 2) Remove access hole lid.

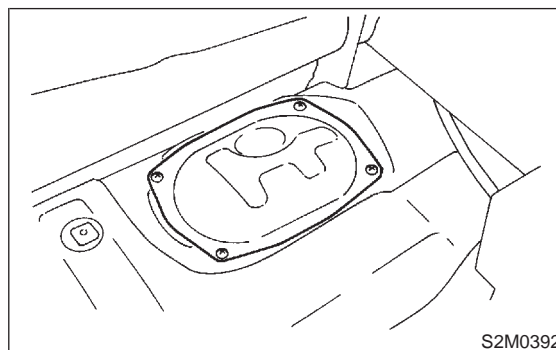

- 3) Disconnect connector from fuel pump.
- 4) Turn ignition switch to ON.
- 5) Read data of fuel temperature sensor signal using Subaru Select Monitor or the OBD-II general scan tool.

**NOTE:**

- Subaru Select Monitor

For detailed operation procedure, refer to the "READ CURRENT DATA SHOWN ON DISPLAY FOR ENGINE". <Ref. to 2-7 [T3C4].>

- OBD-II general scan tool

For detailed operation procedures, refer to the OBD-II General Scan Tool Instruction Manual.

**CHECK** : **Is the value less than -40°C (-40°F)?**

**YES** : Replace fuel temperature sensor. <Ref. to 2-1 [W6A0].>

**NO** : Repair ground short circuit in harness between fuel pump and ECM connector.



**10V1 : CHECK CURRENT DATA.**

- 1) Start engine.
- 2) Read data of fuel temperature sensor signal using Subaru Select Monitor or OBD-II general scan tool.

**NOTE:**

- Subaru Select Monitor

For detailed operation procedure, refer to the "READ CURRENT DATA SHOWN ON DISPLAY FOR ENGINE". <Ref. to 2-7 [T3C4].>

- OBD-II general scan tool

For detailed operation procedures, refer to the OBD-II General Scan Tool Instruction Manual.

**CHECK** : *Is the value less than  $-40^{\circ}\text{C}$  ( $-40^{\circ}\text{F}$ )?*

**YES** : Go to step **10V2**.

**NO** : Repair poor contact.

**NOTE:**

In this case, repair the following:

- Poor contact in fuel pump connector
- Poor contact in ECM connector
- Poor contact in coupling connectors (B22, B99, B98 and R57)

**10V2 : CHECK HARNESS BETWEEN FUEL TEMPERATURE SENSOR AND ECM CONNECTOR.**

- 1) Turn ignition switch to OFF.
- 2) Remove access hole lid.

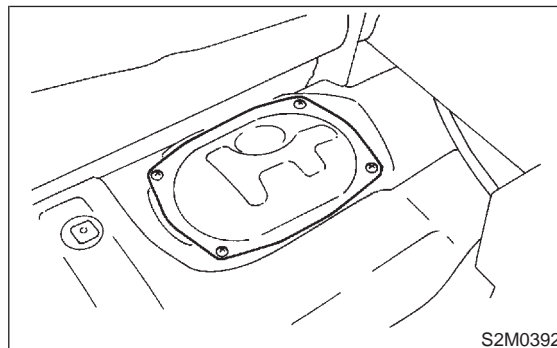

- 3) Disconnect connector from fuel pump.
- 4) Measure voltage between fuel pump connector and chassis ground.

**Connector & terminal**

**(R58) No. 6 (+) — Chassis ground (-):**

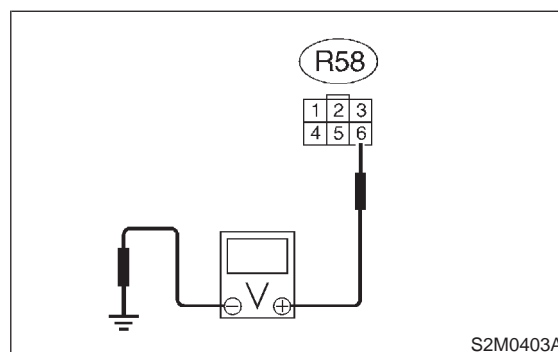

**CHECK** : *Is the voltage more than **10 V**?*

**YES** : Repair battery short circuit in harness between ECM and fuel pump connector.

**NO** : Go to step **10V3**.

**10V3 : CHECK HARNESS BETWEEN FUEL TEMPERATURE SENSOR AND ECM CONNECTOR.**

- 1) Turn ignition switch to ON.
- 2) Measure voltage between fuel pump connector and chassis ground.

**Connector & terminal**

**(R58) No. 6 (+) — Chassis ground (-):**

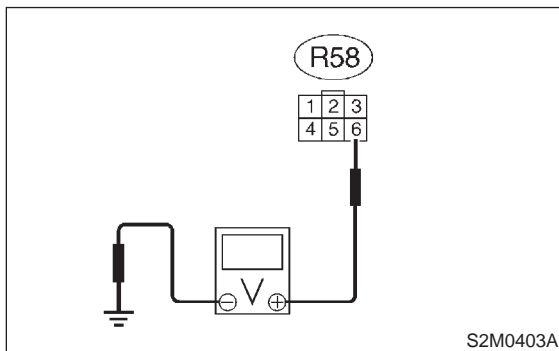

- CHECK** : **Is the voltage more than 10 V?**
- YES** : Repair battery short circuit in harness between ECM and fuel pump connector.
- NO** : Go to step **10V4**.

**10V4 : CHECK HARNESS BETWEEN FUEL TEMPERATURE SENSOR AND ECM CONNECTOR.**

Measure voltage between fuel pump connector and chassis ground.

**Connector & terminal**

**(R58) No. 6 (+) — Chassis ground (-):**

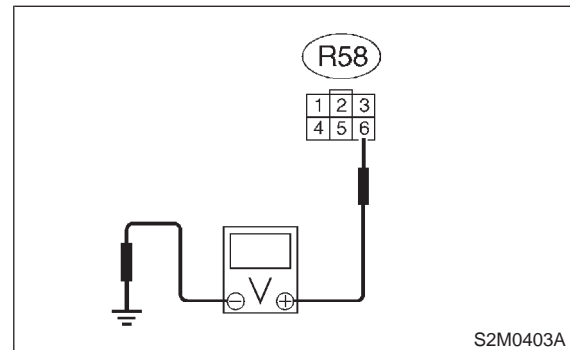

- CHECK** : **Is the voltage more than 4 V?**
- YES** : Go to step **10V5**.
- NO** : Repair harness and connector.

**NOTE:**

In this case, repair the following:

- Open circuit in harness between ECM and fuel pump connector
- Poor contact in fuel pump connector
- Poor contact in ECM connector
- Poor contact in coupling connectors (B98 and R57)

**10V5 : CHECK HARNESS BETWEEN FUEL TEMPERATURE SENSOR AND ECM CONNECTOR.**

- 1) Turn ignition switch to OFF.
- 2) Measure resistance of harness between fuel pump connector and chassis ground.

**Connector & terminal**

**(R58) No. 5 — Chassis ground:**

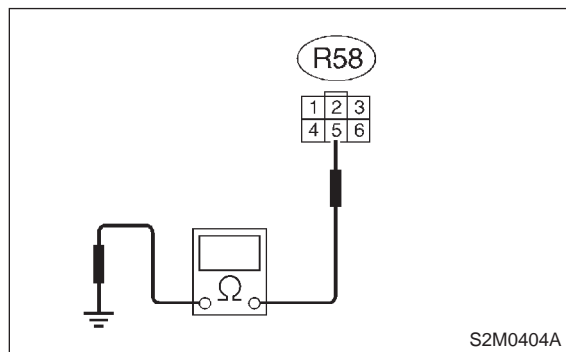

- CHECK** : **Is the resistance less than 5  $\Omega$ ?**
- YES** : Replace fuel temperature sensor. <Ref. to 2-1 [W6A0].>
- NO** : Repair harness and connector.

**NOTE:**

In this case, repair the following:

- Open circuit in harness between ECM and fuel pump connector
- Poor contact in fuel pump connector
- Poor contact in ECM connector
- Poor contact in coupling connectors (B22, B97 and R57)

**W: DTC P0301 — CYLINDER 1 MISFIRE DETECTED —**

NOTE:

For the diagnostic procedure, refer to DTC P0304. <Ref. to 2-7 [T11Z0].>

**X: DTC P0302 — CYLINDER 2 MISFIRE DETECTED —**

NOTE:

For the diagnostic procedure, refer to DTC P0304. <Ref. to 2-7 [T11Z0].>

**Y: DTC P0303 — CYLINDER 3 MISFIRE DETECTED —**

NOTE:

For the diagnostic procedure, refer to DTC P0304. <Ref. to 2-7 [T11Z0].>

**Z: DTC P0304 — CYLINDER 4 MISFIRE DETECTED —**

**• DTC DETECTING CONDITION:**

- Two consecutive driving cycles with fault
- Immediately at fault recognition (A misfire which could damage catalyst occurs.)

**• TROUBLE SYMPTOM:**

- Engine stalls.
- Erroneous idling
- Rough driving

**CAUTION:**

After repair or replacement of faulty parts, conduct CLEAR MEMORY MODE <Ref. to 2-7 [T3D0].> and INSPECTION MODE <Ref. to 2-7 [T3E0].>

**• WIRING DIAGRAM:**

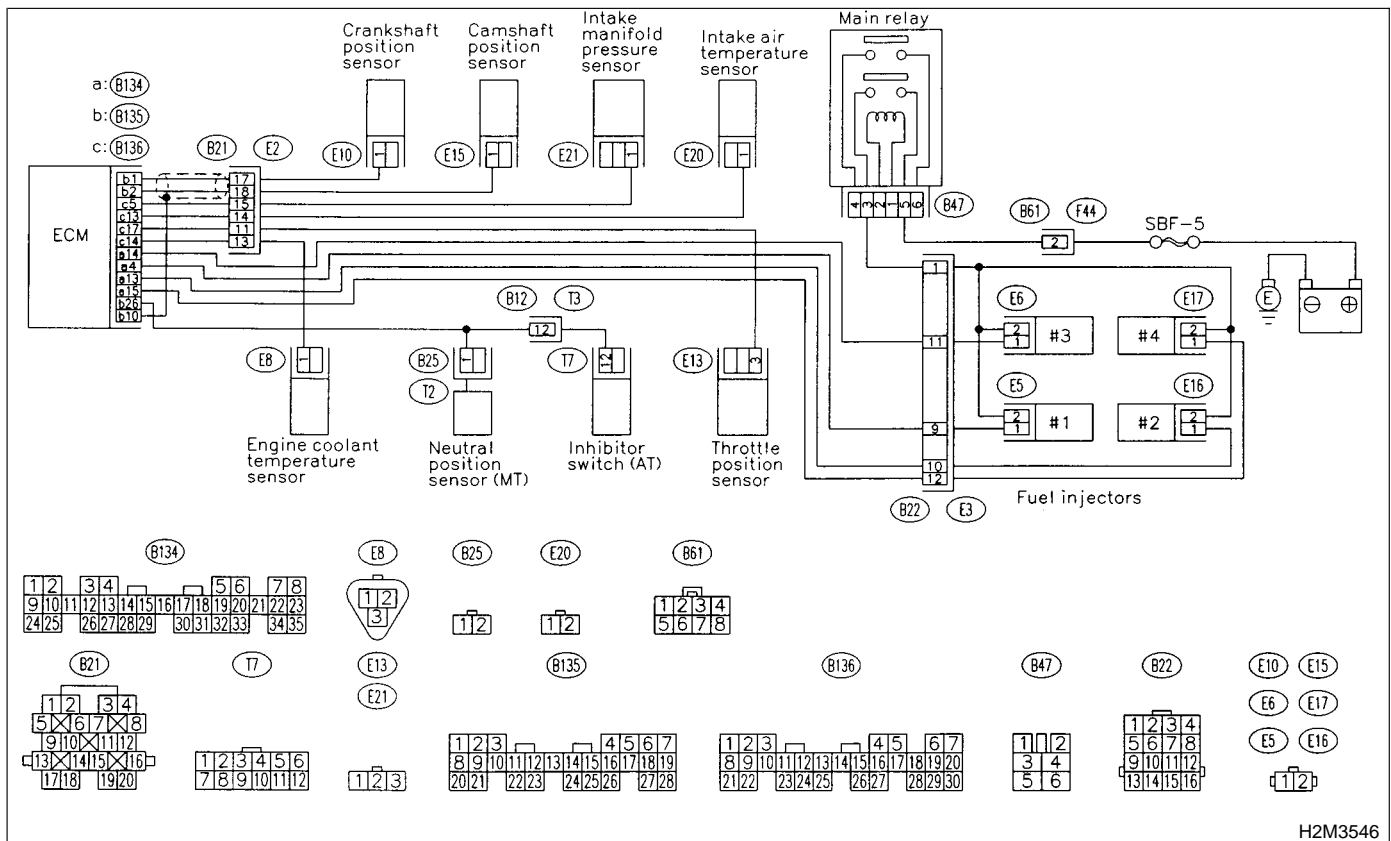

H2M3546

**10Z1 : CHECK ANY OTHER DTC ON DISPLAY.**

**CHECK** : Does the Subaru Select Monitor or OBD-II general scan tool indicate DTC P0106, P0107, P0108, P0116, P0117 or P0125?

**YES** : Inspect DTC P0106, P0107, P0108, P0116, P0117 or P0125 using "10. Diagnostics Chart with Trouble Code". <Ref. to 2-7 [T10A0].>

**NOTE:**

In this case, it is not necessary to inspect DTC P0301, P0302, P0303 and P0304.

**NO** : Go to step 10Z2.

**10Z2 : CHECK OUTPUT SIGNAL FROM ECM.**

- 1) Turn ignition switch to ON.
- 2) Measure voltage between ECM connector and chassis ground on faulty cylinders.

**Connector & terminal**

- #1 (B134) No. 4 (+) — Chassis ground (-):
- #2 (B134) No. 13 (+) — Chassis ground (-):
- #3 (B134) No. 14 (+) — Chassis ground (-):
- #4 (B134) No. 15 (+) — Chassis ground (-):

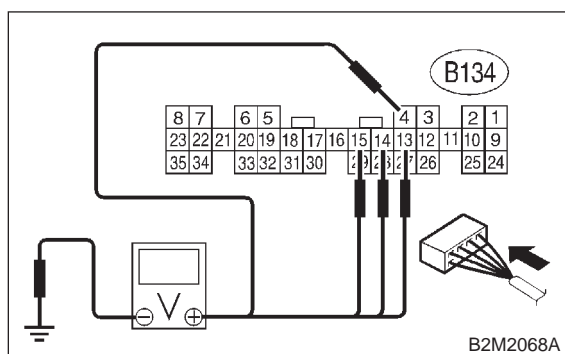

**CHECK** : Is the voltage more than 10 V?

**YES** : Go to step 10Z8.

**NO** : Go to step 10Z3.

**10Z3 : CHECK HARNESS BETWEEN FUEL INJECTOR AND ECM CONNECTOR.**

- 1) Turn ignition switch to OFF.
- 2) Disconnect connector from fuel injector on faulty cylinders.
- 3) Measure voltage between ECM connector and engine ground on faulty cylinders.

**Connector & terminal**

- #1 (E5) No. 1 — Engine ground:
- #2 (E16) No. 1 — Engine ground:
- #3 (E6) No. 1 — Engine ground:
- #4 (E17) No. 1 — Engine ground:

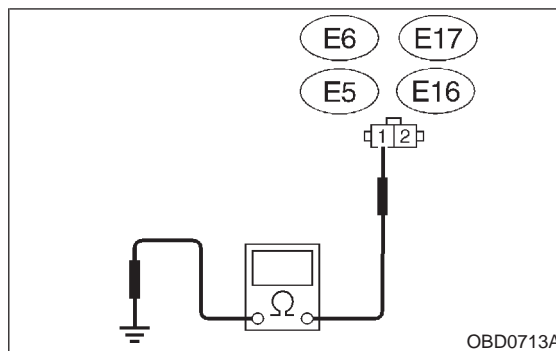

**CHECK** : Is the resistance less than 10 Ω?

**YES** : Repair ground short circuit in harness between fuel injector and ECM connector.

**NO** : Go to step 10Z4.



**10Z4 : CHECK HARNESS BETWEEN FUEL INJECTOR AND ECM CONNECTOR.**

Measure resistance of harness connector between ECM connector and fuel injector on faulty cylinders.

**Connector & terminal**

- #1 (B134) No. 4 — (E5) No. 1:
- #2 (B134) No. 13 — (E16) No. 1:
- #3 (B134) No. 14 — (E6) No. 1:
- #4 (B134) No. 15 — (E17) No. 1:

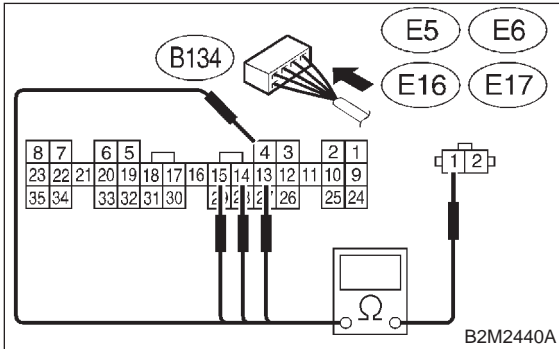

- CHECK** : Is the resistance less than 1 Ω?
- YES** : Go to step 10Z5.
- NO** : Repair harness and connector.

**NOTE:**

In this case, repair the following:

- Open circuit in harness between ECM and fuel injector connector
- Poor contact in coupling connector (B22)

**10Z5 : CHECK FUEL INJECTOR.**

Measure resistance between fuel injector terminals on faulty cylinder.

**Terminals**

**No. 1 — No. 2:**

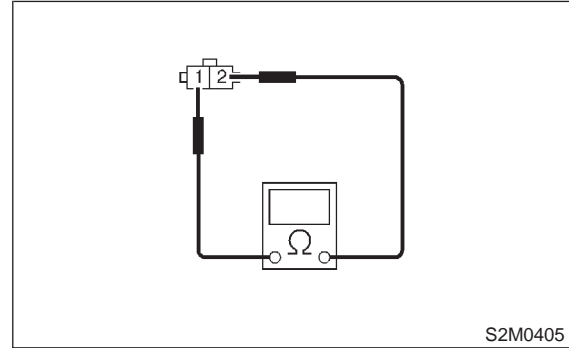

- CHECK** : Is the resistance between 5 and 20 Ω?
- YES** : Go to step 10Z6.
- NO** : Replace faulty fuel injector. <Ref. to 2-7 [W16A0].>

**10Z6 : CHECK MAIN RELAY.**

- 1) Turn the ignition switch to OFF.
- 2) Remove main relay.
- 3) Connect battery to main relay terminals No. 1 and No. 2.
- 4) Measure resistance between main relay terminals.

**Terminals**

**No. 4 — No. 6:**

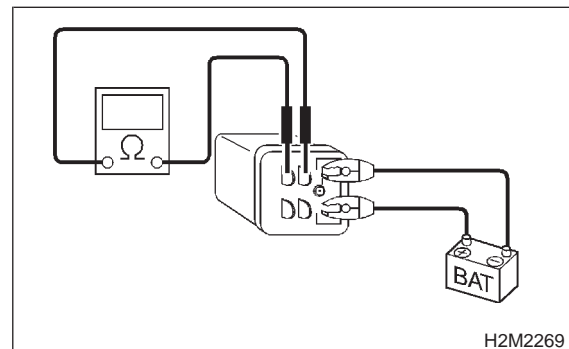

- CHECK** : Is the resistance less than 10 Ω?
- YES** : Go to step 10Z7.
- NO** : Replace main relay.

**10Z7 : CHECK POWER SUPPLY LINE.**

- 1) Turn ignition switch to ON.
- 2) Measure voltage between fuel injector and engine ground on faulty cylinders.

**Connector & terminal**

- #1 (E5) No. 2 (+) — Engine ground (-):
- #2 (E16) No. 2 (+) — Engine ground (-):
- #3 (E6) No. 2 (+) — Engine ground (-):
- #4 (E17) No. 2 (+) — Engine ground (-):

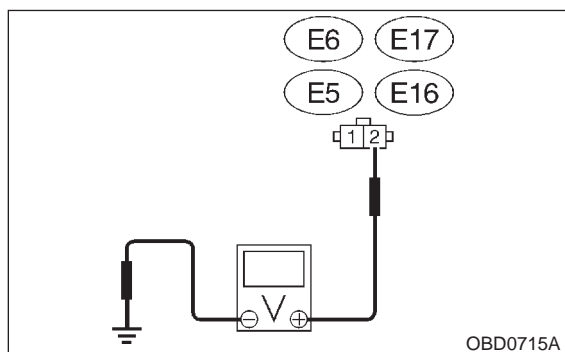

- CHECK** : *Is the voltage more than 10 V?*
- YES** : Repair poor contact in all connectors in fuel injector circuit.
- NO** : Repair harness and connector.

**NOTE:**

In this case, repair the following:

- Open circuit in harness between battery and fuel injector connector on faulty cylinders
- Poor contact in coupling connector (B22)
- Poor contact in main relay connector
- Poor contact in fuel injector connector on faulty cylinders

**10Z8 : CHECK HARNESS BETWEEN FUEL INJECTOR AND ECM CONNECTOR.**

- 1) Turn ignition switch to OFF.
- 2) Disconnect connector from fuel injector on faulty cylinder.
- 3) Turn ignition switch to ON.
- 4) Measure voltage between ECM connector and chassis ground on faulty cylinders.

**Connector & terminal**

- #1 (B134) No. 4 (+) — Chassis ground (-):
- #2 (B134) No. 13 (+) — Chassis ground (-):
- #3 (B134) No. 14 (+) — Chassis ground (-):
- #4 (B134) No. 15 (+) — Chassis ground (-):

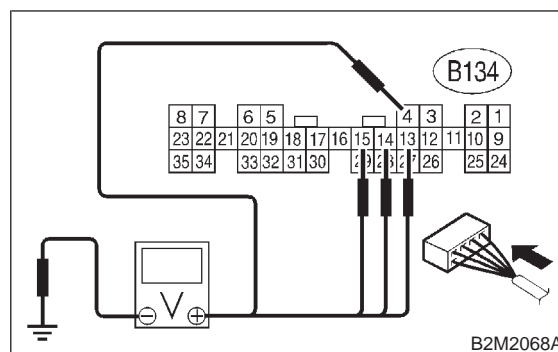

- CHECK** : *Is the voltage more than 10 V?*
- YES** : Repair battery short circuit in harness between ECM and fuel injector. After repair, replace ECM. <Ref. to 2-7 [W17A0].>
- NO** : Go to step **10Z9**.

**10Z9 : CHECK FUEL INJECTOR.**

- 1) Turn ignition switch to OFF.
- 2) Measure resistance between fuel injector terminals on faulty cylinder.

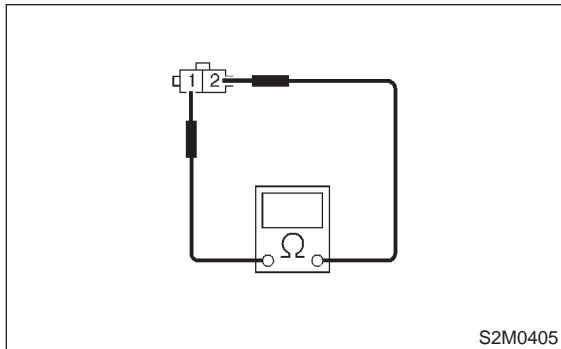
**Terminals****No. 1 — No. 2:**

- CHECK** : **Is the resistance less than 1 Ω?**
- YES** : Replace faulty fuel injector <Ref. to 2-7 [W16A0].> and ECM <Ref. to 2-7 [W17A0].>
- NO** : Go to step **10Z10**.

**10Z10 : CHECK INSTALLATION OF CAMSHAFT POSITION SENSOR/ CRANKSHAFT POSITION SENSOR.**

- CHECK** : **Is camshaft position sensor or crankshaft position sensor loosely installed?**
- YES** : Tighten camshaft position sensor or crankshaft position sensor.
- NO** : Go to step **10Z11**.

**10Z11 : CHECK CRANKSHAFT SPROCKET.**

Remove timing belt cover.

- CHECK** : **Is crankshaft sprocket rusted or does it have broken teeth?**
- YES** : Replace crankshaft sprocket. <Ref. to 2-3 [W3A4].>
- NO** : Go to step **10Z12**.

**10Z12 : CHECK INSTALLATION CONDITION OF TIMING BELT.**

Turn crankshaft using ST. Align mark (a) of sprocket to cylinder block notch (b) and ensure that right side cam sprocket mark (c), cam cap and cylinder head matching surface (d) and/or left side cam sprocket mark (e) and belt cover notch (f) are properly adjusted.

ST 499987500 CRANKSHAFT SOCKET

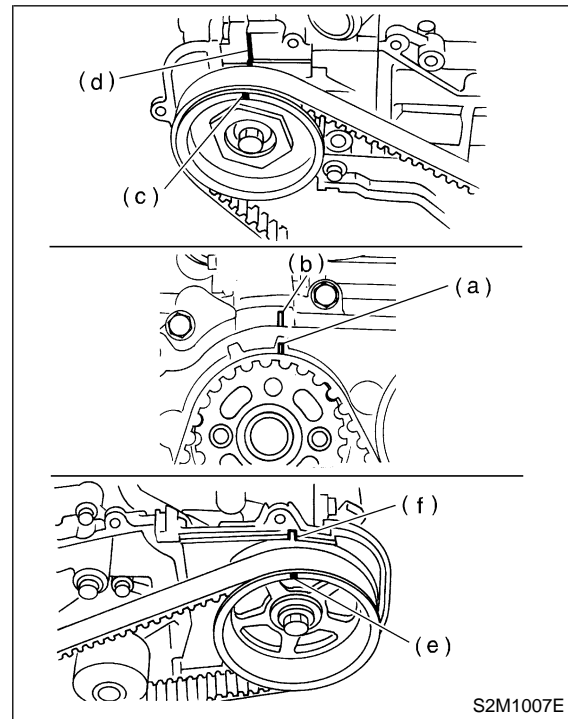

- CHECK** : **Is timing belt dislocated from its proper position?**
- YES** : Repair installation condition of timing belt. <Ref. to 2-3 [W3A0].>
- NO** : Go to step **10Z13**.

**10Z13 : CHECK FUEL LEVEL.**

- CHECK** : **Is the fuel meter indication higher than the "Lower" level?**
- YES** : Go to step **10Z14**.
- NO** : Replenish fuel so fuel meter indication is higher than the "Lower" level. After replenishing fuel, Go to step **10Z14**.

**10Z14 : CHECK STATUS OF CHECK ENGINE MALFUNCTION INDICATOR LAMP (MIL).**

- 1) Clear memory using Subaru Select Monitor.  
<Ref. to 2-7 [T3D0].>
- 2) Start engine, and drive the vehicle more than 10 minutes.

**CHECK** : *Is the MIL coming on or blinking?*

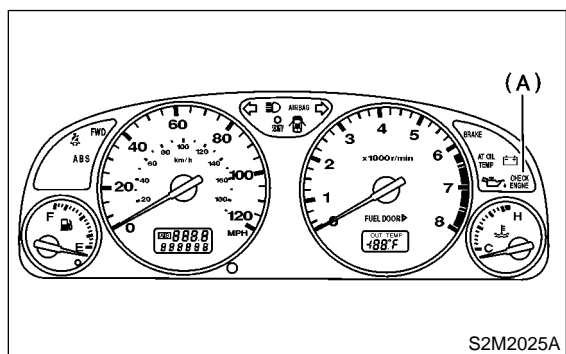

(A) Malfunction indicator lamp (MIL)

**YES** : Go to step **10Z16**.

**NO** : Go to step **10Z15**.

**10Z15 : CHECK CAUSE OF MISFIRE DIAGNOSED.**

**CHECK** : *Was the cause of misfire diagnosed when the engine is running?*

**YES** : Finish diagnostics operation, if the engine has no abnormality.

**NOTE:**

Ex. Remove spark plug cord, etc.

**NO** : Repair poor contact.

**NOTE:**

In this case, repair the following:

- Poor contact in ignitor connector
- Poor contact in ignition coil connector
- Poor contact in fuel injector connector on faulty cylinders
- Poor contact in ECM connector
- Poor contact in coupling connector (B22)

**10Z16 : CHECK AIR INTAKE SYSTEM.**

**CHECK** : *Is there a fault in air intake system?*

**YES** : Repair air intake system.

**NOTE:**

Check the following items:

- Are there air leaks or air suction caused by loose or dislocated nuts and bolts?
- Are there cracks or any disconnection of hoses?

**NO** : Go to step **10Z17**.

**10Z17 : CHECK MISFIRE SYMPTOM.**

- 1) Turn ignition switch to ON.
- 2) Read diagnostic trouble code (DTC).
  - Subaru Select Monitor  
<Ref. to 2-7 [T3C2].>
  - OBD-II general scan tool

For detailed operation procedures, refer to the OBD-II General Scan Tool Operation Manual.

**NOTE:**

Perform diagnosis according to the items listed below.

**CHECK** : *Does the Subaru Select Monitor or OBD-II general scan tool indicate only one DTC?*

**YES** : Go to step **10Z22**.

**NO** : Go to step **10Z18**.

**10Z18 : CHECK DIAGNOSTIC TROUBLE CODE (DTC) ON DISPLAY.**

**CHECK** : *Does the Subaru Select Monitor or OBD-II general scan tool indicate DTC P0301 and P0302?*

**YES** : Go to step **10Z23**.

**NO** : Go to step **10Z19**.

**10Z19 : CHECK DIAGNOSTIC TROUBLE CODE (DTC) ON DISPLAY.**

**CHECK** : *Does the Subaru Select Monitor or OBD-II general scan tool indicate DTC P0303 and P0304?*

**YES** : Go to step **10Z24**.

**NO** : Go to step **10Z20**.

**10Z20 : CHECK DIAGNOSTIC TROUBLE CODE (DTC) ON DISPLAY.**

**CHECK** : *Does the Subaru Select Monitor or OBD-II general scan tool indicate DTC P0301 and P0303?*

**YES** : Go to step 10Z25.

**NO** : Go to step 10Z21.

**10Z21 : CHECK DIAGNOSTIC TROUBLE CODE (DTC) ON DISPLAY.**

**CHECK** : *Does the Subaru Select Monitor or OBD-II general scan tool indicate DTC P0302 and P0304?*

**YES** : Go to step 10Z26.

**NO** : Go to step 10Z27.

**10Z22 : ONLY ONE CYLINDER**

**CHECK** : *Is there a fault in that cylinder?*

**YES** : Repair or replace faulty parts.

NOTE:

Check the following items.

- Spark plug
- Spark plug cord
- Fuel injector
- Compression ratio

**NO** : Go to DTC P0170. <Ref. to 2-7 [T10S0].>

**10Z23 : GROUP OF #1 AND #2 CYLINDERS**

**CHECK** : *Are there faults in #1 and #2 cylinders?*

**YES** : Repair or replace faulty parts.

NOTE:

- Check the following items.

- Spark plugs
- Fuel injectors
- Ignition coil
- Compression ratio

- If no abnormal is discovered, check for "8. D: IGNITION CONTROL SYSTEM" of #1 and #2 cylinders side. <Ref. to 2-7 [T8D0].>

**NO** : Go to DTC P0170. <Ref. to 2-7 [T10S0].>

**10Z24 : GROUP OF #3 AND #4 CYLINDERS**

**CHECK** : *Are there faults in #3 and #4 cylinders?*

**YES** : Repair or replace faulty parts.

NOTE:

- Check the following items.

- Spark plugs
- Fuel injectors
- Ignition coil

- If no abnormal is discovered, check for "8. D: IGNITION CONTROL SYSTEM" of #3 and #4 cylinders side. <Ref. to 2-7 [T8D0].>

**NO** : Go to DTC P0170. <Ref. to 2-7 [T10S0].>

**10Z25 : GROUP OF #1 AND #3 CYLINDERS**

**CHECK** : *Are there faults in #1 and #3 cylinders?*

**YES** : Repair or replace faulty parts.

NOTE:

Check the following items.

- Spark plugs
- Fuel injectors
- Skipping timing belt teeth

**NO** : Go to DTC P0170. <Ref. to 2-7 [T10S0].>

**10Z26 : GROUP OF #2 AND #4 CYLINDERS**

**CHECK** : *Are there faults in #2 and #4 cylinders?*

**YES** : Repair or replace faulty parts.

NOTE:

Check the following items.

- Spark plugs
- Fuel injectors
- Compression ratio
- Skipping timing belt teeth

**NO** : Go to DTC P0170. <Ref. to 2-7 [T10S0].>

**10Z27 : CYLINDER AT RANDOM**

**CHECK** : *Is the engine idle rough?*

**YES** : Go to DTC P0170. <Ref. to 2-7 [T10S0].>

**NO** : Repair or replace faulty parts.

**NOTE:**

Check the following items.

- Spark plugs
- Fuel injectors
- Compression ratio

**AA: DTC P0325 — KNOCK SENSOR CIRCUIT HIGH INPUT —**

- **DTC DETECTING CONDITION:**
  - Immediately at fault recognition
- **TROUBLE SYMPTOM:**
  - Poor driving performance
  - Knocking occurs.

**CAUTION:**

After repair or replacement of faulty parts, conduct CLEAR MEMORY MODE <Ref. to 2-7 [T3D0].> and INSPECTION MODE <Ref. to 2-7 [T3E0].>

● **WIRING DIAGRAM:**

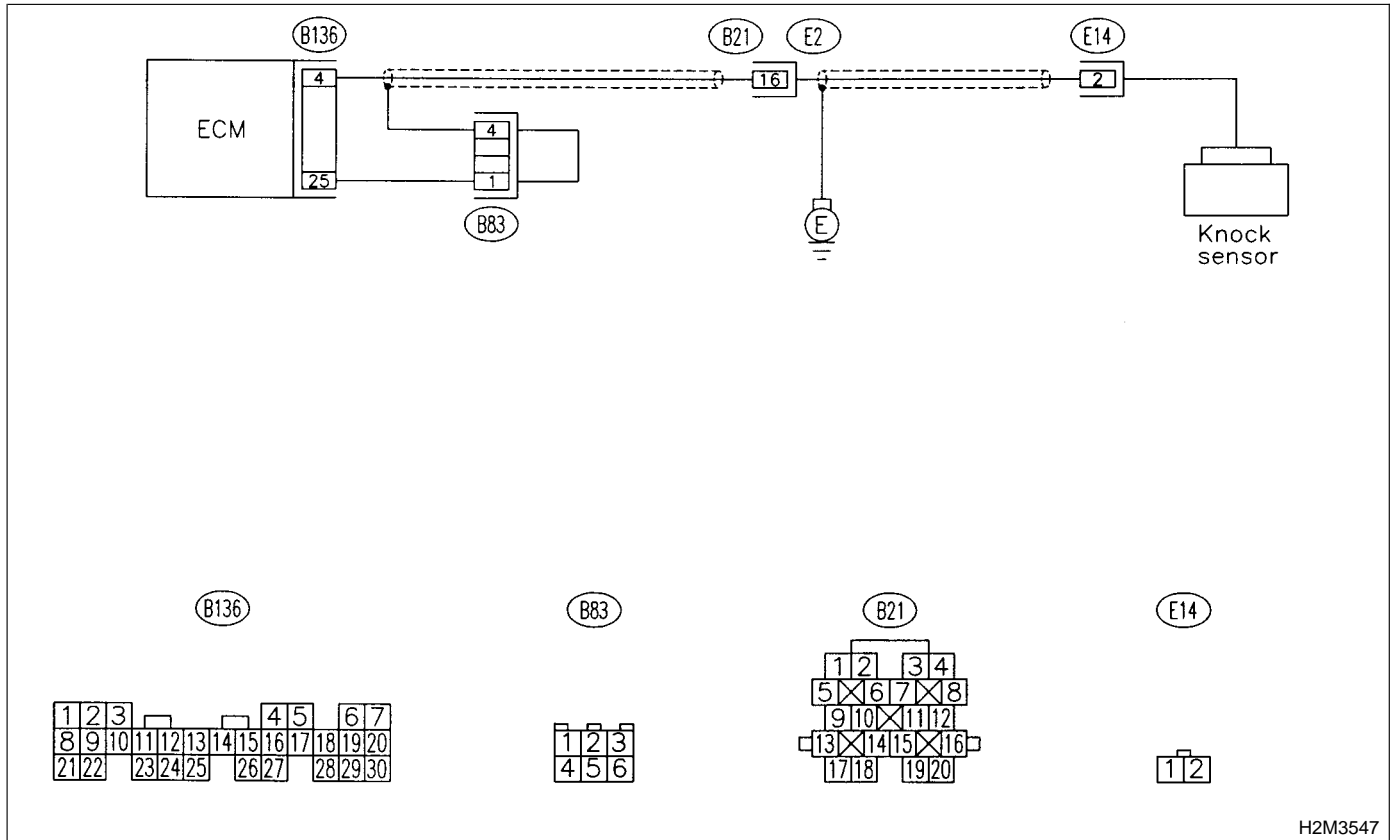

H2M3547

**10AA1 : CHECK HARNESS BETWEEN KNOCK SENSOR AND ECM CONNECTOR.**

- 1) Turn ignition switch to OFF.
- 2) Disconnect connector from ECM.
- 3) Measure resistance between ECM harness connector and chassis ground.

**Connector & terminal**  
**(B136) No. 4 — Chassis ground:**

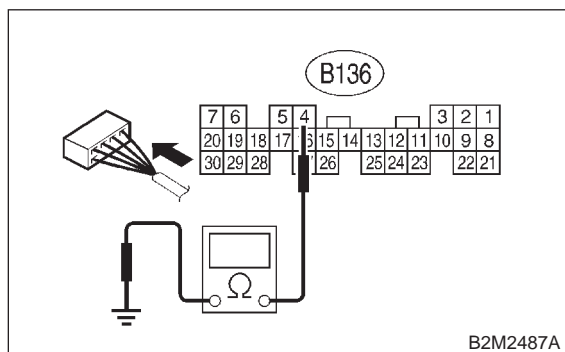

- CHECK** : *Is the resistance more than 700 kΩ?*
- YES** : Go to step 10AA3.
- NO** : Go to step 10AA2.

**10AA2 : CHECK HARNESS BETWEEN KNOCK SENSOR AND ECM CONNECTOR.**

Measure resistance of harness between ECM connector and chassis ground.

**Connector & terminal**  
**(B136) No. 4 — Chassis ground:**

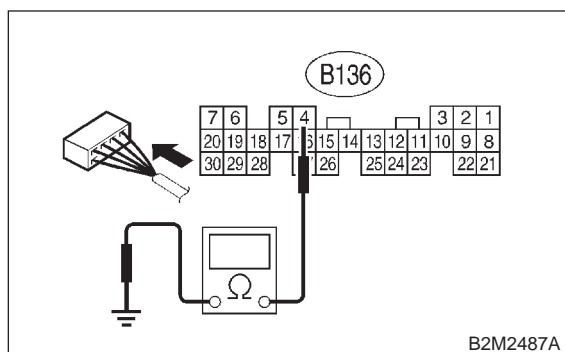

- CHECK** : *Is the resistance less than 400 kΩ?*
- YES** : Go to step 10AA5.
- NO** : Go to step 10AA6.

**10AA3 : CHECK KNOCK SENSOR.**

- 1) Disconnect connector from knock sensor.
- 2) Measure resistance between knock sensor connector terminal and engine ground.

**Terminal**  
**No. 2 — Engine ground:**

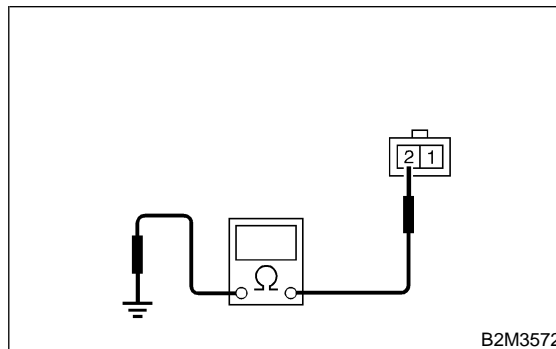

- CHECK** : *Is the resistance more than 700 kΩ?*
- YES** : Go to step 10AA4.
- NO** : Repair harness and connector.

**NOTE:**

In this case, repair the following:

- Open circuit in harness between knock sensor and ECM connector
- Poor contact in knock sensor connector
- Poor contact in coupling connector (B21)

**10AA4 : CHECK CONDITION OF KNOCK SENSOR INSTALLATION.**

- CHECK** : *Is the knock sensor installation bolt tightened securely?*
- YES** : Replace knock sensor. <Ref. to 2-7 [W7A0].>
- NO** : Tighten knock sensor installation bolt securely.



**10AA5 : CHECK KNOCK SENSOR.**

- 1) Disconnect connector from knock sensor.
- 2) Measure resistance between knock sensor connector terminal and engine ground.

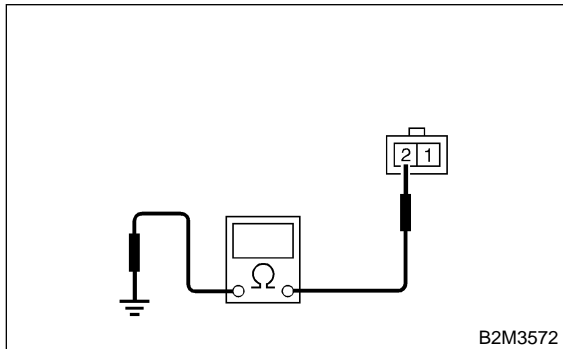
**Terminal****No. 2 — Engine ground:**

- CHECK** : **Is the resistance less than 400 kΩ?**
- YES** : Replace knock sensor. <Ref. to 2-7 [W7A0].>
- NO** : Repair ground short circuit in harness between knock sensor connector and ECM connector.

**NOTE:**

The harness between both connectors is shielded. Repair short circuit of harness together with shield.

**10AA6 : CHECK INPUT SIGNAL FOR ECM.**

- 1) Connect connectors to ECM and knock sensor.
- 2) Turn ignition switch to ON.
- 3) Measure voltage between ECM and chassis ground.

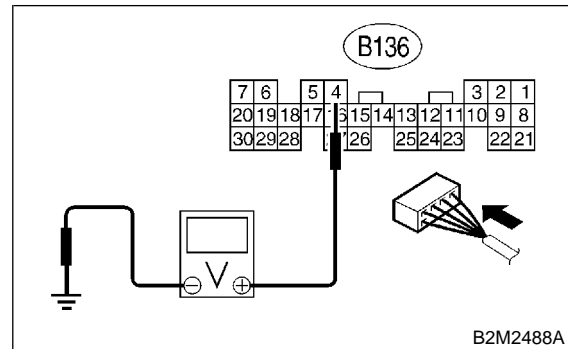
**Connector & terminal****(B136) No. 4 (+) — Chassis ground (-):**

- CHECK** : **Is the voltage more than 2 V?**
- YES** : Even if MIL lights up, the circuit has returned to a normal condition at this time. (However, the possibility of poor contact still remains.)

**NOTE:**

In this case, repair the following:

- Poor contact in knock sensor connector
  - Poor contact in ECM connector
  - Poor contact in coupling connector (B21)
- NO** : Repair poor contact in ECM connector.

**MEMO:**

**AB: DTC P0335 — CRANKSHAFT POSITION SENSOR CIRCUIT MALFUNCTION —**

- **DTC DETECTING CONDITION:**
  - Immediately at fault recognition
- **TROUBLE SYMPTOM:**
  - Engine stalls.
  - Failure of engine to start

**CAUTION:**

After repair or replacement of faulty parts, conduct CLEAR MEMORY MODE <Ref. to 2-7 [T3D0].> and INSPECTION MODE <Ref. to 2-7 [T3E0].>.

● **WIRING DIAGRAM:**

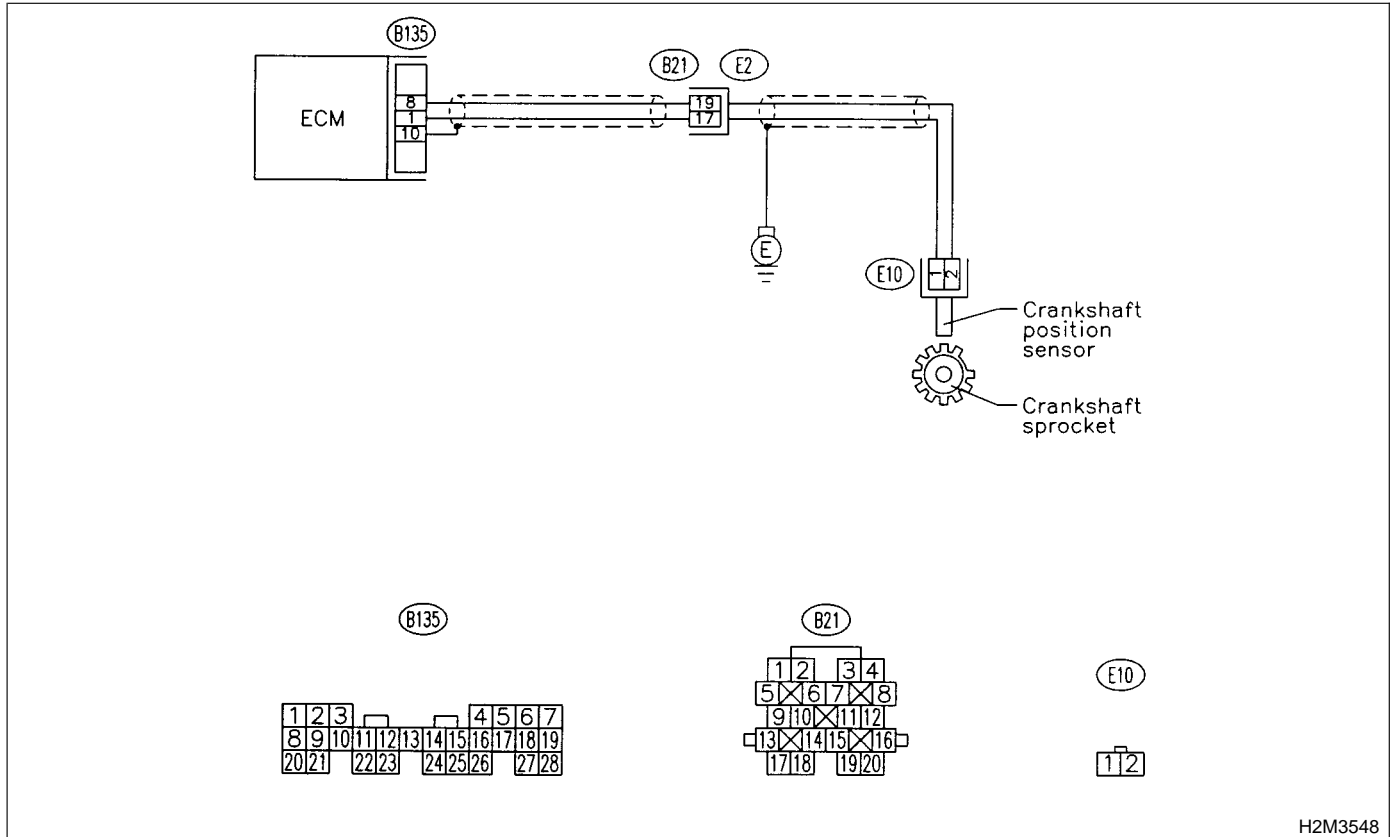

H2M3548

**10AB1 : CHECK HARNESS BETWEEN CRANKSHAFT POSITION SENSOR AND ECM CONNECTOR.**

- 1) Turn ignition switch to OFF.
- 2) Disconnect connector from crankshaft position sensor.
- 3) Measure resistance of harness between crankshaft position sensor connector and engine ground.

**Connector & terminal**  
**(E10) No. 1 — Engine ground:**

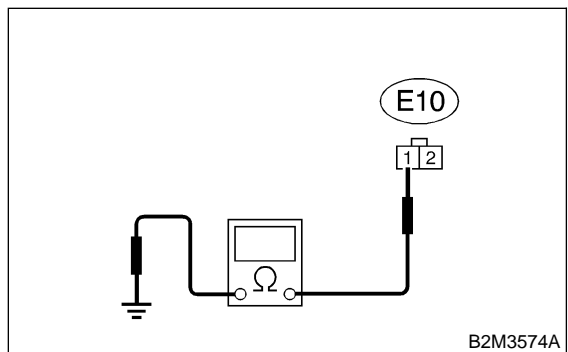

- CHECK** : *Is the resistance more than 100 kΩ?*
- YES** : Repair harness and connector.

**NOTE:**

In this case, repair the following:

- Open circuit in harness between crankshaft position sensor and ECM connector
- Poor contact in ECM connector
- Poor contact in coupling connector (B21)

- NO** : Go to step **10AB2**.

**10AB2 : CHECK HARNESS BETWEEN CRANKSHAFT POSITION SENSOR AND ECM CONNECTOR.**

Measure resistance of harness between crankshaft position sensor connector and engine ground.

**Connector & terminal**  
**(E10) No. 1 — Engine ground:**

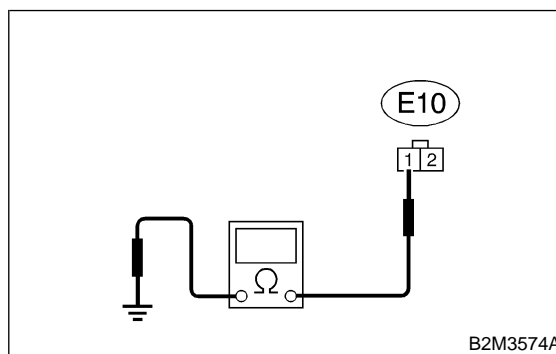

- CHECK** : *Is the resistance less than 10 Ω?*
- YES** : Repair ground short circuit in harness between crankshaft position sensor and ECM connector.

**NOTE:**

The harness between both connectors are shielded. Repair ground short circuit in harness together with shield.

- NO** : Go to step **10AB3**.

**10AB3 : CHECK HARNESS BETWEEN CRANKSHAFT POSITION SENSOR AND ECM CONNECTOR.**

Measure resistance of harness between crankshaft position sensor connector and engine ground.

**Connector & terminal**

**(E10) No. 2 — Engine ground:**

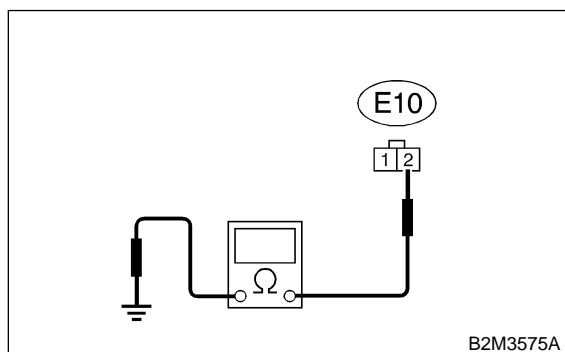

**CHECK** : **Is the resistance less than 5 Ω?**

**YES** : Go to step **10AB4**.

**NO** : Repair harness and connector.

**NOTE:**

In this case, repair the following:

- Open circuit in harness between crankshaft position sensor and ECM connector
- Poor contact in ECM connector
- Poor contact in coupling connector (B21)

**10AB4 : CHECK CONDITION OF CRANKSHAFT POSITION SENSOR.**

**CHECK** : **Is the crankshaft position sensor installation bolt tightened securely?**

**YES** : Go to step **10AB5**.

**NO** : Tighten crankshaft position sensor installation bolt securely.

**10AB5 : CHECK CRANKSHAFT POSITION SENSOR.**

- 1) Remove crankshaft position sensor.
- 2) Measure resistance between connector terminals of crankshaft position sensor.

**Terminals**

**No. 1 — No. 2:**

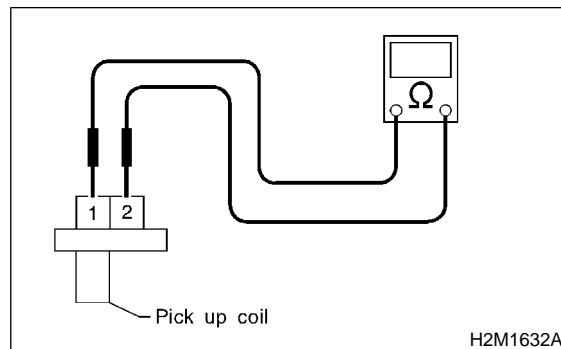

**CHECK** : **Is the resistance between 1 and 4 kΩ?**

**YES** : Repair poor contact in crankshaft position sensor connector.

**NO** : Replace crankshaft position sensor. <Ref. to 2-7 [W5A0].>

MEMO:

**AC: DTC P0336 — CRANKSHAFT POSITION SENSOR CIRCUIT RANGE/PERFORMANCE PROBLEM —**

- **DTC DETECTING CONDITION:**
  - Immediately at fault recognition
- **TROUBLE SYMPTOM:**
  - Engine stalls.
  - Failure of engine to start

**CAUTION:**

After repair or replacement of faulty parts, conduct CLEAR MEMORY MODE <Ref. to 2-7 [T3D0].> and INSPECTION MODE <Ref. to 2-7 [T3E0].>

● **WIRING DIAGRAM:**

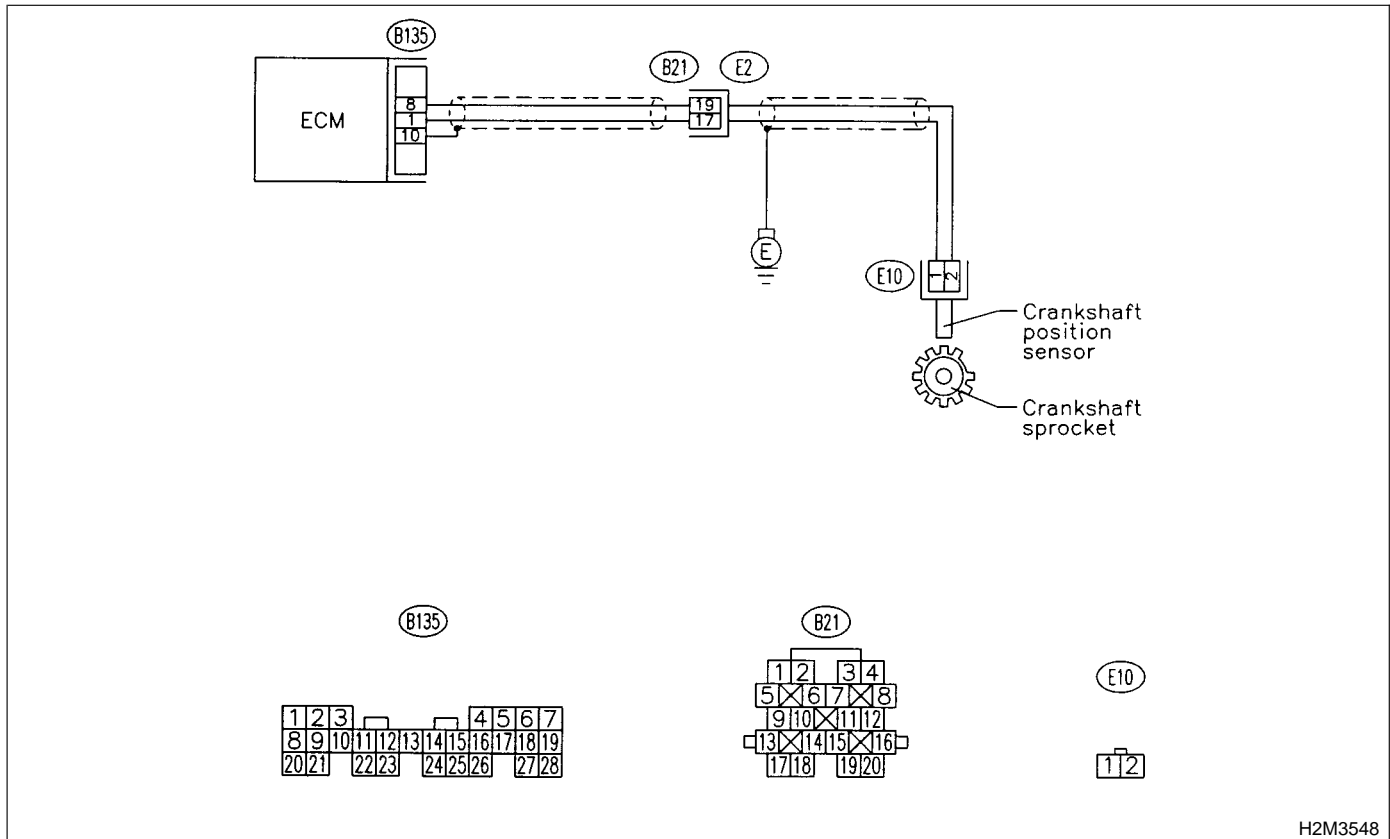

H2M3548

**10AC1 : CHECK ANY OTHER DTC ON DISPLAY.**

- CHECK** : Does the Subaru Select Monitor or OBD-II general scan tool indicate DTC P0335?
- YES** : Inspect DTC P0335 using "10. Diagnostics Chart with Trouble Code". <Ref. to 2-7 [T10A0].>
- NO** : Go to step **10AC2**.

**10AC2 : CHECK CONDITION OF CRANKSHAFT POSITION SENSOR.**

- Turn ignition switch to OFF.
- CHECK** : Is the crankshaft position sensor installation bolt tightened securely?
- YES** : Go to step **10AC3**.
- NO** : Tighten crankshaft position sensor installation bolt securely.

**10AC3 : CHECK CRANKSHAFT SPROCKET.**

Remove front belt cover.

**CHECK** : **Are crankshaft sprocket teeth cracked or damaged?**

**YES** : Replace crankshaft sprocket. <Ref. to 2-3 [W3A0].>

**NO** : Go to step **10AC4**.

**10AC4 : CHECK INSTALLATION CONDITION OF TIMING BELT.**

Turn crankshaft using ST. Align mark (a) of sprocket to cylinder block notch (b) and ensure that right side cam sprocket mark (c), cam cap and cylinder head matching surface (d) and/or left side cam sprocket mark (e) and belt cover notch (f) are properly adjusted.

ST 499987500 CRANKSHAFT SOCKET

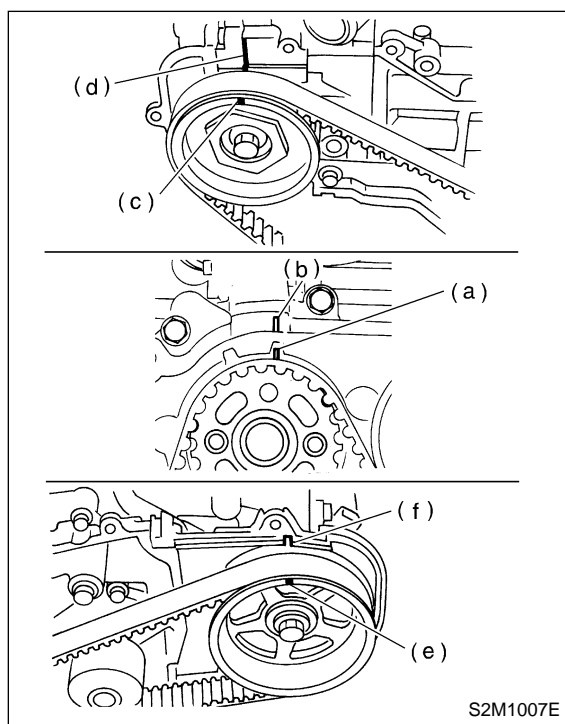

**CHECK** : **Is timing belt dislocated from its proper position?**

**YES** : Repair installation condition of timing belt. <Ref. to 2-3 [W3A0].>

**NO** : Replace crankshaft position sensor. <Ref. to 2-7 [W5A0].>



**AD: DTC P0340 — CAMSHAFT POSITION SENSOR CIRCUIT MALFUNCTION**

- **DTC DETECTING CONDITION:**
  - Immediately at fault recognition
- **TROUBLE SYMPTOM:**
  - Engine stalls.
  - Failure of engine to start

**CAUTION:**

After repair or replacement of faulty parts, conduct CLEAR MEMORY MODE <Ref. to 2-7 [T3D0].> and INSPECTION MODE <Ref. to 2-7 [T3E0].>

● **WIRING DIAGRAM:**

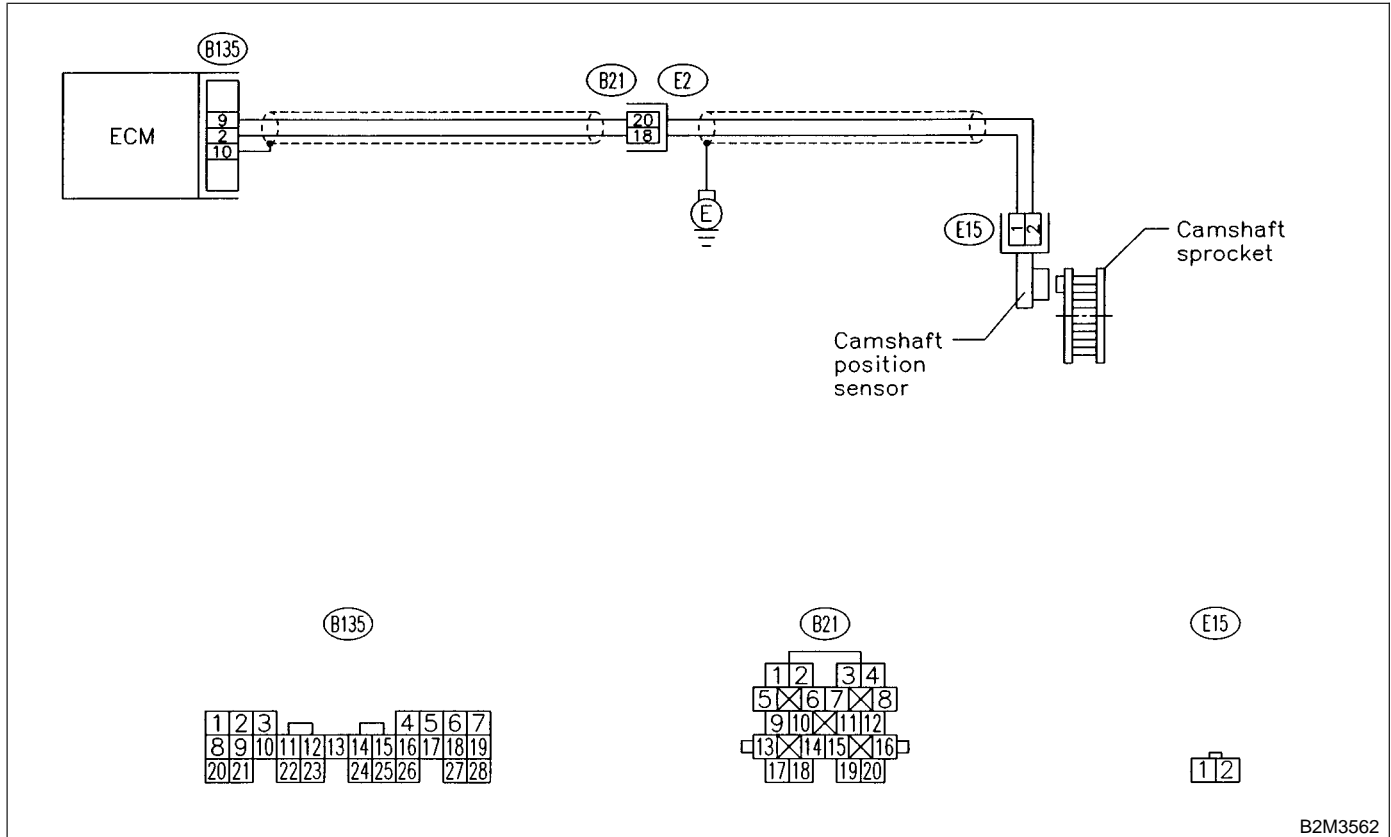

B2M3562

**10AD1 : CHECK HARNESS BETWEEN CAMSHAFT POSITION SENSOR AND ECM CONNECTOR.**

- 1) Turn ignition switch to OFF.
- 2) Disconnect connector from camshaft position sensor.
- 3) Measure resistance of harness between camshaft position sensor connector and engine ground.

**Connector & terminal**  
**(E15) No. 1 — Engine ground:**

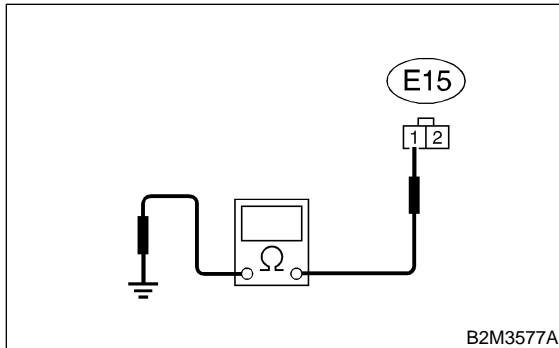

- CHECK** : **Is the resistance more than 100 kΩ?**  
**YES** : Repair harness and connector.

**NOTE:**

In this case, repair the following:

- Open circuit in harness between camshaft position sensor and ECM connector
- Poor contact in ECM connector
- Poor contact in coupling connector (B21)

- NO** : Go to step **10AD2**.

**10AD2 : CHECK HARNESS BETWEEN CAMSHAFT POSITION SENSOR AND ECM CONNECTOR.**

Measure resistance of harness between camshaft position sensor connector and engine ground.

**Connector & terminal**  
**(E15) No. 1 — Engine ground:**

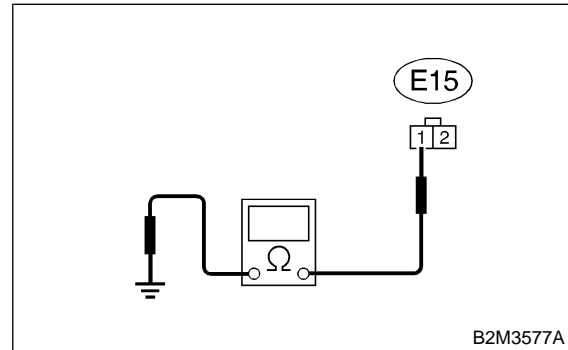

- CHECK** : **Is the resistance less than 10 Ω?**  
**YES** : Repair ground short circuit in harness between camshaft position sensor and ECM connector.

**NOTE:**

The harness between both connectors are shielded. Repair ground short circuit in harness together with shield.

- NO** : Go to step **10AD3**.

**10AD3 : CHECK HARNESS BETWEEN CAMSHAFT POSITION SENSOR AND ECM CONNECTOR.**

Measure resistance of harness between camshaft position sensor connector and engine ground.

**Connector & terminal**

**(E15) No. 2 — Engine ground:**

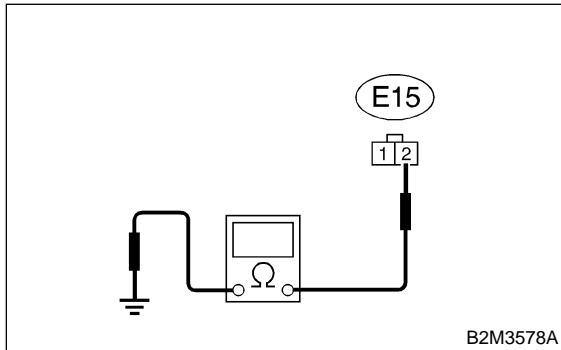

- CHECK** : **Is the resistance less than 5 Ω?**  
**YES** : Go to step **10AD4**.  
**NO** : Repair harness and connector.

**NOTE:**

In this case, repair the following:

- Open circuit in harness between camshaft position sensor and ECM connector
- Poor contact in ECM connector
- Poor contact in coupling connector (B21)

**10AD4 : CHECK CONDITION OF CAMSHAFT POSITION SENSOR.**

- CHECK** : **Is the camshaft position sensor installation bolt tightened securely?**  
**YES** : Go to step **10AD5**.  
**NO** : Tighten camshaft position sensor installation bolt securely.

**10AD5 : CHECK CAMSHAFT POSITION SENSOR.**

- 1) Remove camshaft position sensor.
- 2) Measure resistance between connector terminals of camshaft position sensor.

**Terminals**

**No. 1 — No. 2:**

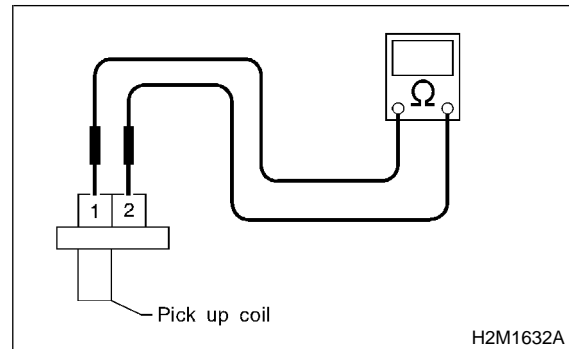

- CHECK** : **Is the resistance between 1 and 4 kΩ?**  
**YES** : Repair poor contact in camshaft position sensor connector.  
**NO** : Replace camshaft position sensor. <Ref. to 2-7 [W6A0].>

MEMO:

**AE: DTC P0341 — CAMSHAFT POSITION SENSOR CIRCUIT RANGE/PERFORMANCE PROBLEM —**

- **DTC DETECTING CONDITION:**
  - Immediately at fault recognition
- **TROUBLE SYMPTOM:**
  - Engine stalls.
  - Failure of engine to start

**CAUTION:**

After repair or replacement of faulty parts, conduct CLEAR MEMORY MODE <Ref. to 2-7 [T3D0].> and INSPECTION MODE <Ref. to 2-7 [T3E0].>

● **WIRING DIAGRAM:**

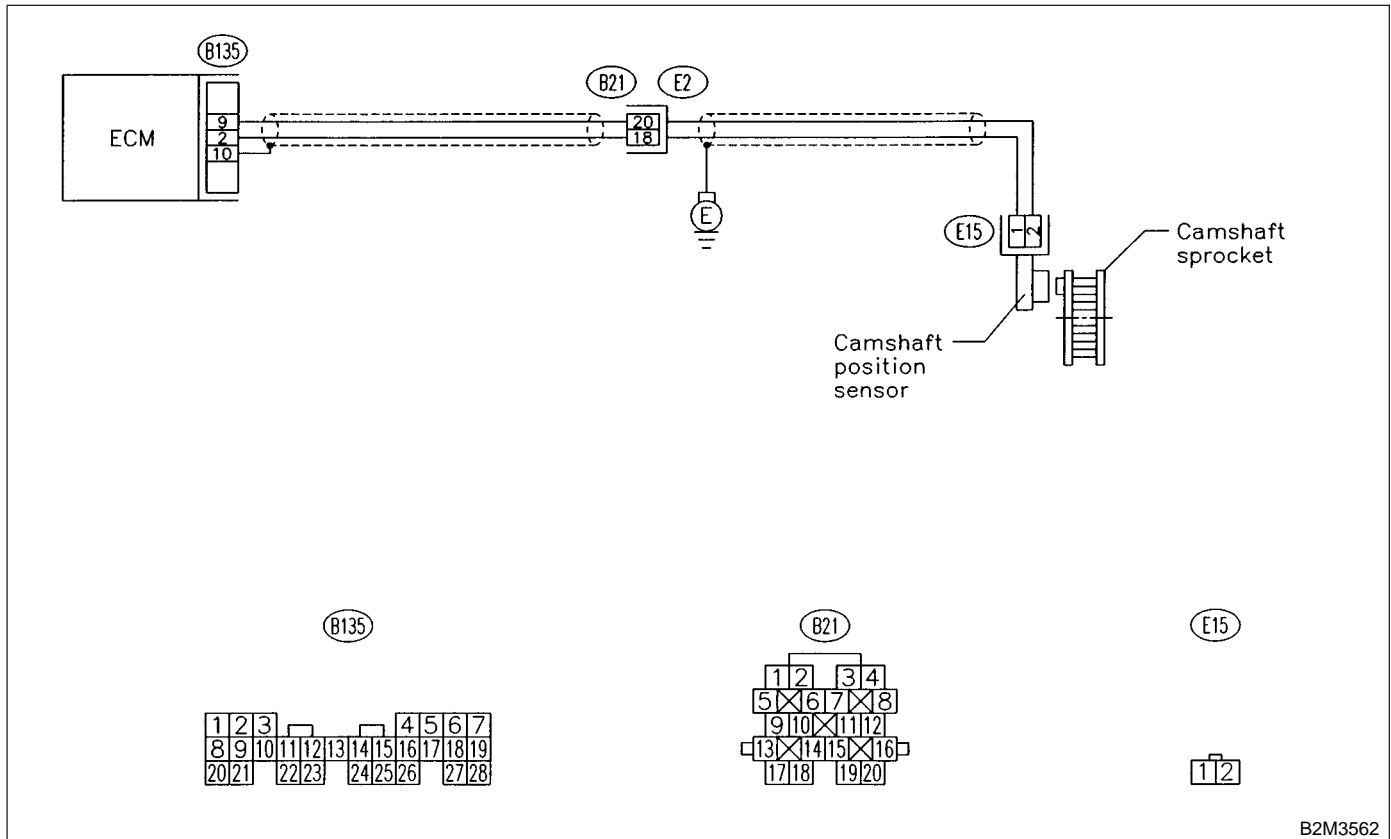

B2M3562

**10AE1 : CHECK ANY OTHER DTC ON DISPLAY.**

- CHECK** : Does the Subaru Select Monitor or OBD-II general scan tool indicate DTC P0340?
- YES** : Inspect DTC P0340 using "10. Diagnostics Chart with Trouble Code". <Ref. to 2-7 [T10A0].>
- NO** : Go to step **10AE2**.

**10AE2 : CHECK HARNESS BETWEEN CAMSHAFT POSITION SENSOR AND ECM CONNECTOR.**

- 1) Turn ignition switch to OFF.
- 2) Disconnect connector from camshaft position sensor.
- 3) Measure resistance of harness between camshaft position sensor connector and engine ground.

**Connector & terminal**

**(E15) No. 1 — Engine ground:**

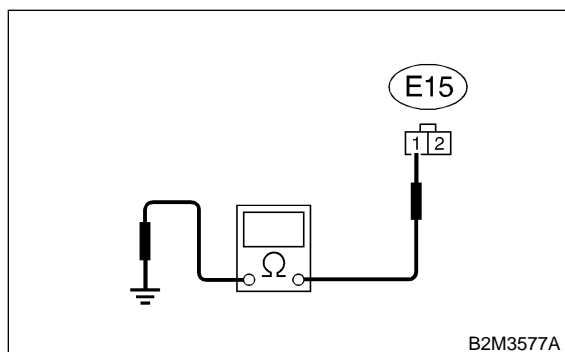

**CHECK** : **Is the resistance more than 100 kΩ?**

**YES** : Repair harness and connector.

**NOTE:**

In this case, repair the following:

- Open circuit in harness between camshaft position sensor and ECM connector
- Poor contact in ECM connector
- Poor contact in coupling connector (B21)

**NO** : Go to step **10AE3**.

**10AE3 : CHECK HARNESS BETWEEN CAMSHAFT POSITION SENSOR AND ECM CONNECTOR.**

Measure resistance of harness between camshaft position sensor connector and engine ground.

**Connector & terminal**

**(E15) No. 1 — Engine ground:**

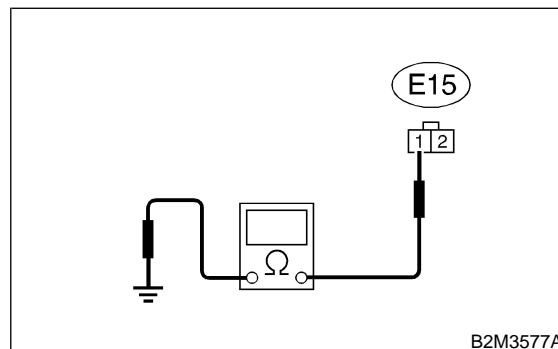

**CHECK** : **Is the resistance less than 10 Ω?**

**YES** : Repair ground short circuit in harness between camshaft position sensor and ECM connector.

**NOTE:**

The harness between both connectors are shielded. Repair ground short circuit in harness together with shield.

**NO** : Go to step **10AE4**.

**10AE4 : CHECK HARNESS BETWEEN CAMSHAFT POSITION SENSOR AND ECM CONNECTOR.**

Measure resistance of harness between camshaft position sensor connector and engine ground.

**Connector & terminal**

**(E15) No. 2 — Engine ground:**

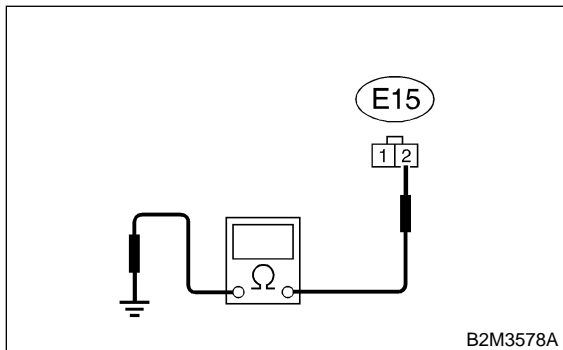

**CHECK** : **Is the resistance less than 5  $\Omega$ ?**

**YES** : Go to step **10AE5**.

**NO** : Repair harness and connector.

**NOTE:**

In this case, repair the following:

- Open circuit in harness between camshaft position sensor and ECM connector
- Poor contact in ECM connector
- Poor contact in coupling connector (B21)

**10AE5 : CHECK CONDITION OF CAMSHAFT POSITION SENSOR.**

**CHECK** : **Is the camshaft position sensor installation bolt tightened securely?**

**YES** : Go to step **10AE6**.

**NO** : Tighten camshaft position sensor installation bolt securely.

**10AE6 : CHECK CAMSHAFT POSITION SENSOR.**

- 1) Remove camshaft position sensor.
- 2) Measure resistance between connector terminals of camshaft position sensor.

**Terminals**

**No. 1 — No. 2:**

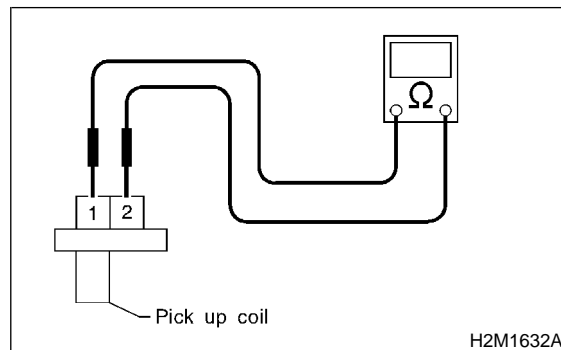

**CHECK** : **Is the resistance between 1 and 4  $k\Omega$ ?**

**YES** : Go to step **10AE7**.

**NO** : Replace camshaft position sensor. <Ref. to 2-7 [W6A0].>

**10AE7 : CHECK CONDITION OF CAMSHAFT POSITION SENSOR.**

Turn ignition switch to OFF.

**CHECK** : **Is the camshaft position sensor installation bolt tightened securely?**

**YES** : Go to step **10AE8**.

**NO** : Tighten camshaft position sensor installation bolt securely.

**10AE8 : CHECK CAMSHAFT SPROCKET.**

Remove front belt cover. <Ref. to 2-3 [W3A0].>

**CHECK** : **Are camshaft sprocket teeth cracked or damaged?**

**YES** : Replace camshaft sprocket. <Ref. to 2-3 [W3A0].>

**NO** : Go to step **10AE9**.

**10AE9 : CHECK INSTALLATION CONDITION OF TIMING BELT.**

Turn crankshaft using ST. Align mark (a) of sprocket to cylinder block notch (b) and ensure that right side cam sprocket mark (c), cam cap and cylinder head matching surface (d) and/or left side cam sprocket mark (e) and belt cover notch (f) are properly adjusted.

ST 499987500 CRANKSHAFT SOCKET

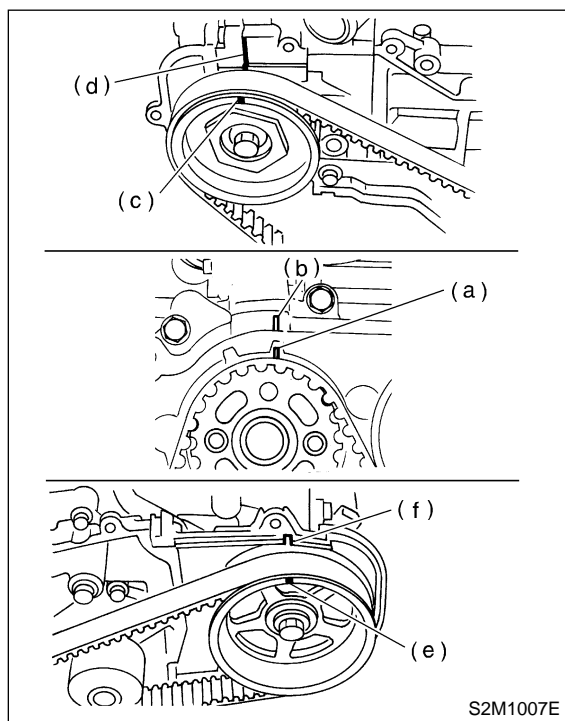

**CHECK** : ***Is timing belt dislocated from its proper position?***

**YES** : Repair installation condition of timing belt. <Ref. to 2-3 [W3A0].>

**NO** : Replace camshaft position sensor. <Ref. to 2-7 [W6A0].>



**AF: DTC P0420 — CATALYST SYSTEM EFFICIENCY BELOW THRESHOLD**

- **DTC DETECTING CONDITION:**
  - Two consecutive driving cycles with fault
- **TROUBLE SYMPTOM:**
  - Engine stalls.
  - Idle mixture is out of specifications.

**CAUTION:**

After repair or replacement of faulty parts, conduct CLEAR MEMORY MODE <Ref. to 2-7 [T3D0].> and INSPECTION MODE <Ref. to 2-7 [T3E0].>

● **WIRING DIAGRAM:**

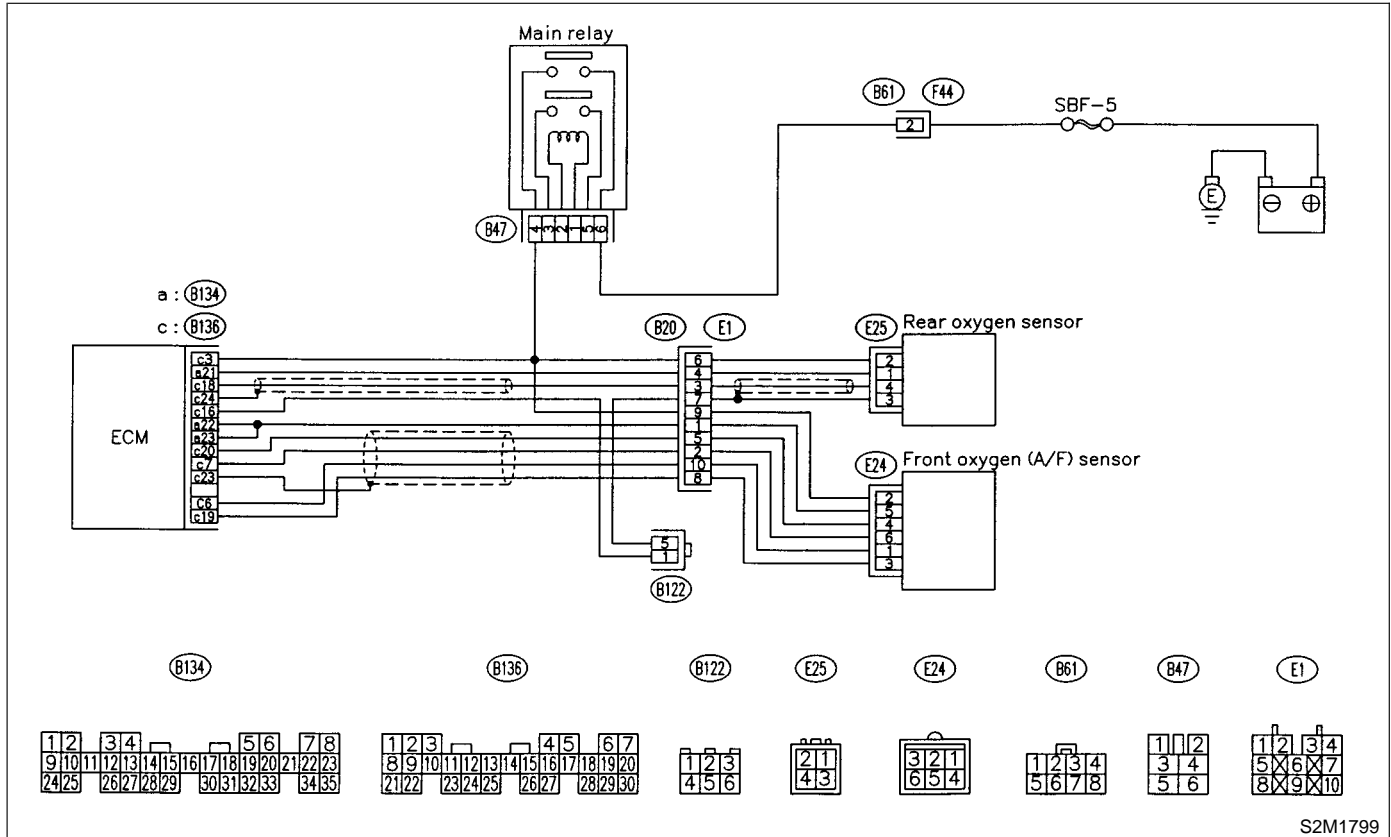

S2M1799

**10AF1 : CHECK ANY OTHER DTC ON DISPLAY.**

**CHECK** : *Does the Subaru Select Monitor or OBD-II general scan tool indicate DTC P0130, P0133, P0136, P0139, P0141, P0301, P0302, P0303, P0304, P1130, P1131, P1132, P1133 and P1151?*

**YES** : Inspect the relevant DTC using "10. Diagnostics Chart with Trouble Code". <Ref. to 2-7 [T10A0].>

NOTE:

In this case, it is not necessary to inspect DTC P0420.

**NO** : Go to step **10AF2**.

**10AF2 : CHECK EXHAUST SYSTEM.**

Check for gas leaks or air suction caused by loose or dislocated nuts and bolts, and open hole at exhaust pipes.

NOTE:

Check the following positions.

- Between cylinder head and front exhaust pipe
- Between front exhaust pipe and front catalytic converter
- Between front catalytic converter and rear catalytic converter

**CHECK** : *Is there a fault in exhaust system?*

**YES** : Repair or replace exhaust system. <Ref. to 2-9 [W1A0].>

**NO** : Go to step **10AF3**.

**10AF3 : CHECK REAR CATALYTIC CONVERTER.**

Separate rear catalytic converter from rear exhaust pipe.

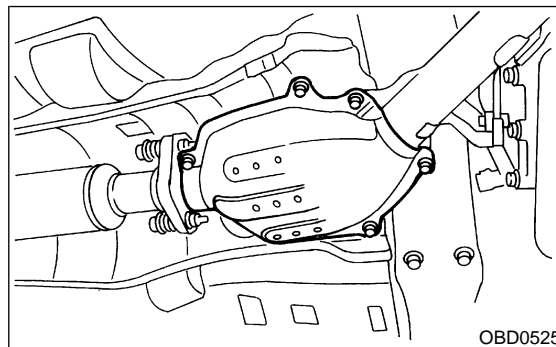

**CHECK** : *Is there damage at rear face of rear catalyst?*

**YES** : Replace front catalytic converter <Ref. to 2-1 [W1A0].> and rear catalytic converter <Ref. to 2-1 [W2A0].>

**NO** : Go to step **10AF4**.

**10AF4 : CHECK FRONT CATALYTIC CONVERTER.**

Remove front catalytic converter.

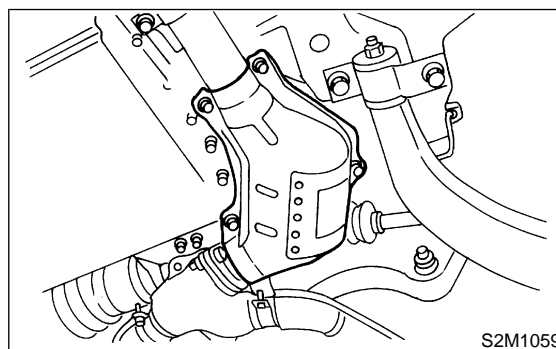

**CHECK** : *Is there damage at rear face or front face of front catalyst?*

**YES** : Replace front catalytic converter. <Ref. to 2-1 [W1A0].>

**NO** : Contact with SOA service.

NOTE:

Inspection by DTM is required, because probable cause is deterioration of multiple parts.

**AG: DTC P0440 — EVAPORATIVE EMISSION CONTROL SYSTEM MALFUNCTION —**

**• DTC DETECTING CONDITION:**

- Two consecutive driving cycles with fault

**• TROUBLE SYMPTOM:**

- Gasoline smell
- There is a hole of more than 1.0 mm (0.04 in) dia. in evaporation system or fuel tank.

**CAUTION:**

After repair or replacement of faulty parts, conduct CLEAR MEMORY MODE <Ref. to 2-7 [T3D0].> and INSPECTION MODE <Ref. to 2-7 [T3E0].>

**• WIRING DIAGRAM:**

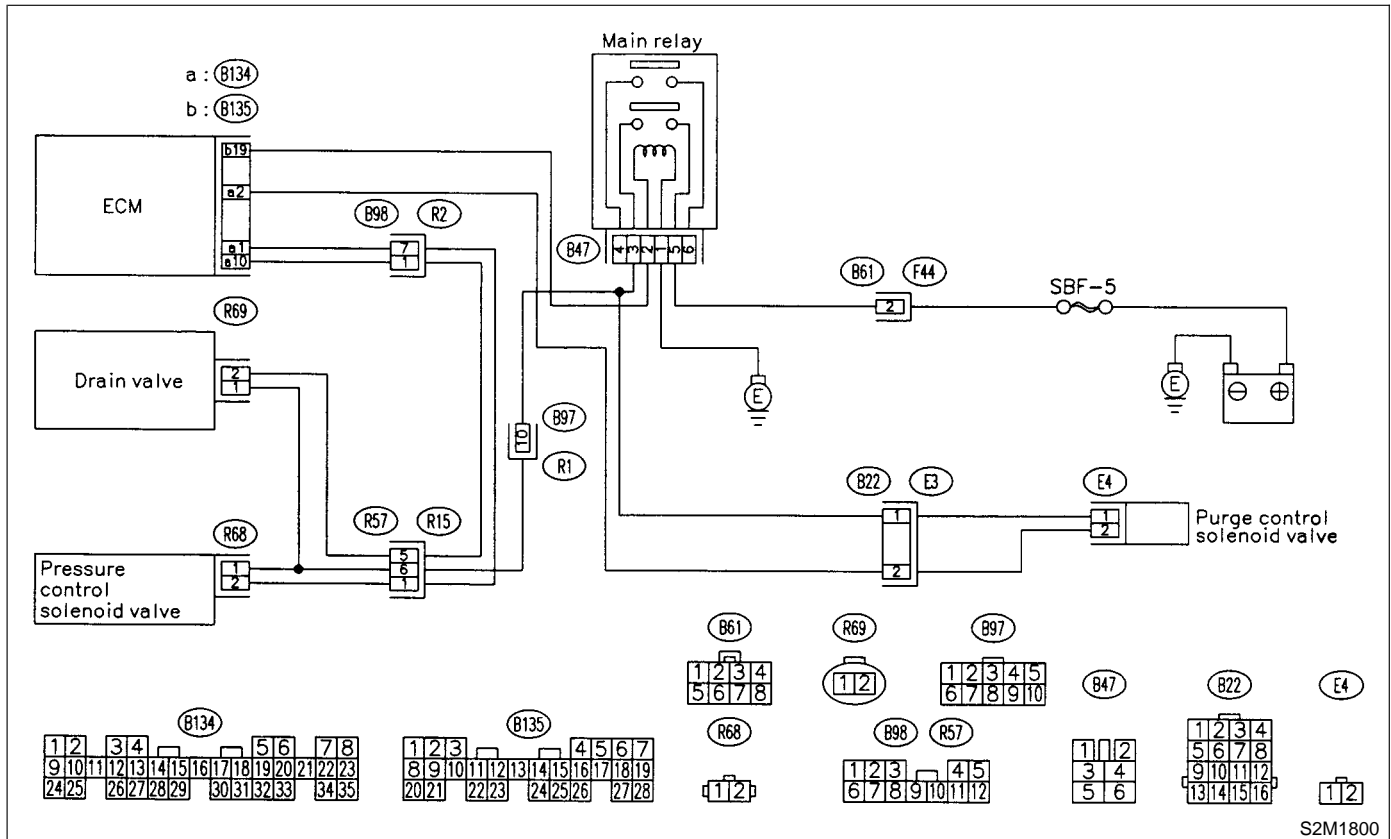

S2M1800

**10AG1 : CHECK ANY OTHER DTC ON DISPLAY.**

- CHECK** : *Is there any other DTC on display?*
- YES** : Inspect the relevant DTC using "10. Diagnostics Chart with Trouble Code". <Ref. to 2-7 [T10A0].>
- NO** : Go to step **10AG2**.

**10AG2 : CHECK FUEL FILLER CAP.**

- 1) Turn ignition switch to OFF.
- 2) Check the fuel filler cap.

**NOTE:**  
The DTC code is stored in memory if fuel filler cap is or was loose or if the cap chain was caught while tightening.

- CHECK** : *Is the fuel filler cap tightened securely?*
- YES** : Go to step **10AG3**.
- NO** : Tighten fuel filler cap securely.

**10AG3 : CHECK FUEL FILLER PIPE PACKING.**

- CHECK** : *Is there any damage to the seal between fuel filler cap and fuel filler pipe?*
- YES** : Repair or replace fuel filler cap and fuel filler pipe. <Ref. to 2-8 [W2A0].>
- NO** : Go to step **10AG4**.

**10AG4 : CHECK DRAIN VALVE.**

1) Connect test mode connector.

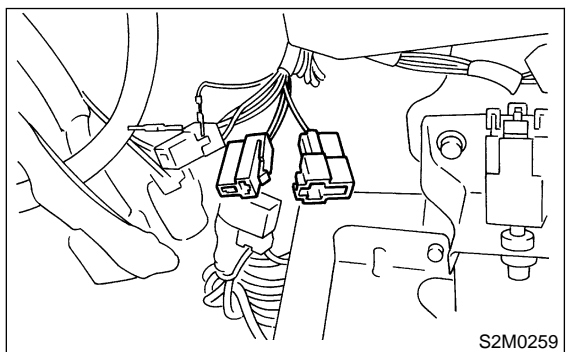

- 2) Turn ignition switch to ON.
- 3) Operate drain valve.

**NOTE:**

Drain valve operation can also be executed using Subaru Select Monitor. For the procedure, refer to "COMPULSORY VALVE OPERATION CHECK MODE". <Ref. to 2-7 [T3F0].>

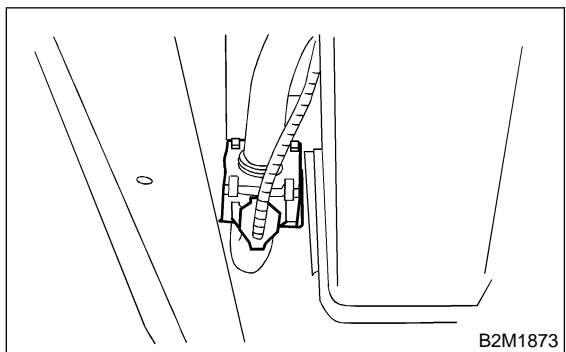

- CHECK** : *Does drain valve produce operating sound?*
- YES** : Go to step **10AG5**.
- NO** : Replace drain valve. <Ref. to 2-1 [W13A0].>

**10AG5 : CHECK PURGE CONTROL SOLENOID VALVE.**

Operate purge control solenoid valve.

**NOTE:**

Purge control solenoid valve operation can also be executed using Subaru Select Monitor. For the procedure, refer to "COMPULSORY VALVE OPERATION CHECK MODE". <Ref. to 2-7 [T3F0].>

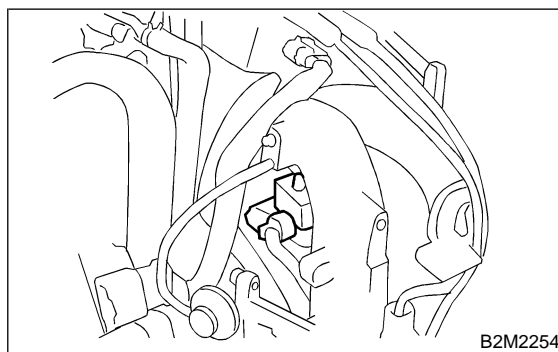

- CHECK** : *Does purge control solenoid valve produce operating sound?*
- YES** : Go to step **10AG6**.
- NO** : Replace purge control solenoid valve. <Ref. to 2-1 [W4A0].>

**10AG6 : CHECK PRESSURE CONTROL SOLENOID VALVE.**

Operate pressure control solenoid valve.

**NOTE:**

Pressure control solenoid valve operation can also be executed using Subaru Select Monitor. For the procedure, refer to "COMPULSORY VALVE OPERATION CHECK MODE". <Ref. to 2-7 [T3F0].>

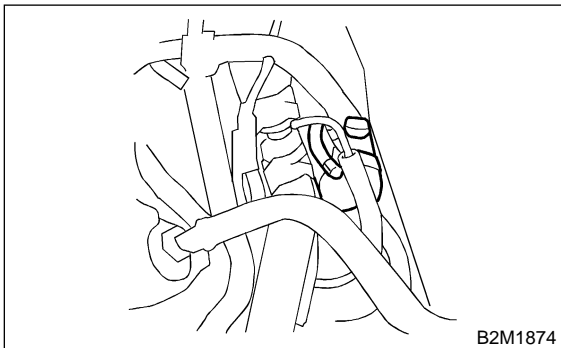

- CHECK** : **Does pressure control solenoid valve produce operating sound?**
- YES** : Go to step **10AG7**.
- NO** : Replace pressure control solenoid valve. <Ref. to 2-1 [W9A0].>

**10AG7 : CHECK EVAPORATIVE EMISSION CONTROL SYSTEM LINE.**

Turn ignition switch to OFF.

- CHECK** : **Is there a hole of more than 1.0 mm (0.04 in) dia. on fuel line?**
- YES** : Repair or replace fuel line. <Ref. to 2-8 [W8A0].>
- NO** : Go to step **10AG8**.

**10AG8 : CHECK CANISTER.**

- CHECK** : **Is canister damaged or is there a hole of more than 1.0 mm (0.04 in) dia. in it?**
- YES** : Repair or replace canister. <Ref. to 2-1 [W3A0].>
- NO** : Go to step **10AG9**.

**10AG9 : CHECK FUEL TANK.**

Remove fuel tank. <Ref. to 2-8 [W1C0].>

- CHECK** : **Is fuel tank damaged or is there a hole of more than 1.0 mm (0.04 in) dia. in it?**
- YES** : Repair or replace fuel tank. <Ref. to 2-8 [W1C0].>
- NO** : Go to step **10AG10**.

**10AG10 : CHECK ANY OTHER MECHANICAL TROUBLE IN EVAPORATIVE EMISSION CONTROL SYSTEM.**

- CHECK** : **Are there holes of more than 1.0 mm (0.04 in) dia., cracks, clogging or disconnections of hoses or pipes in evaporative emission control system?**
- YES** : Repair or replace hoses or pipes.
- NO** : Contact with SOA service.

**NOTE:**

Inspection by DTM is required, because probable cause is deterioration of multiple parts.

**MEMO:**

**AH: DTC P0442 — EVAPORATIVE EMISSION CONTROL SYSTEM MALFUNCTION —**

**• DTC DETECTING CONDITION:**

- Two consecutive driving cycles with fault

**• TROUBLE SYMPTOM:**

- Gasoline smell
- There is a hole of more than 0.5 mm (0.020 in) dia. in evaporation system or fuel tank.

**CAUTION:**

After repair or replacement of faulty parts, conduct CLEAR MEMORY MODE <Ref. to 2-7 [T3D0].> and INSPECTION MODE <Ref. to 2-7 [T3E0].>

**• WIRING DIAGRAM:**

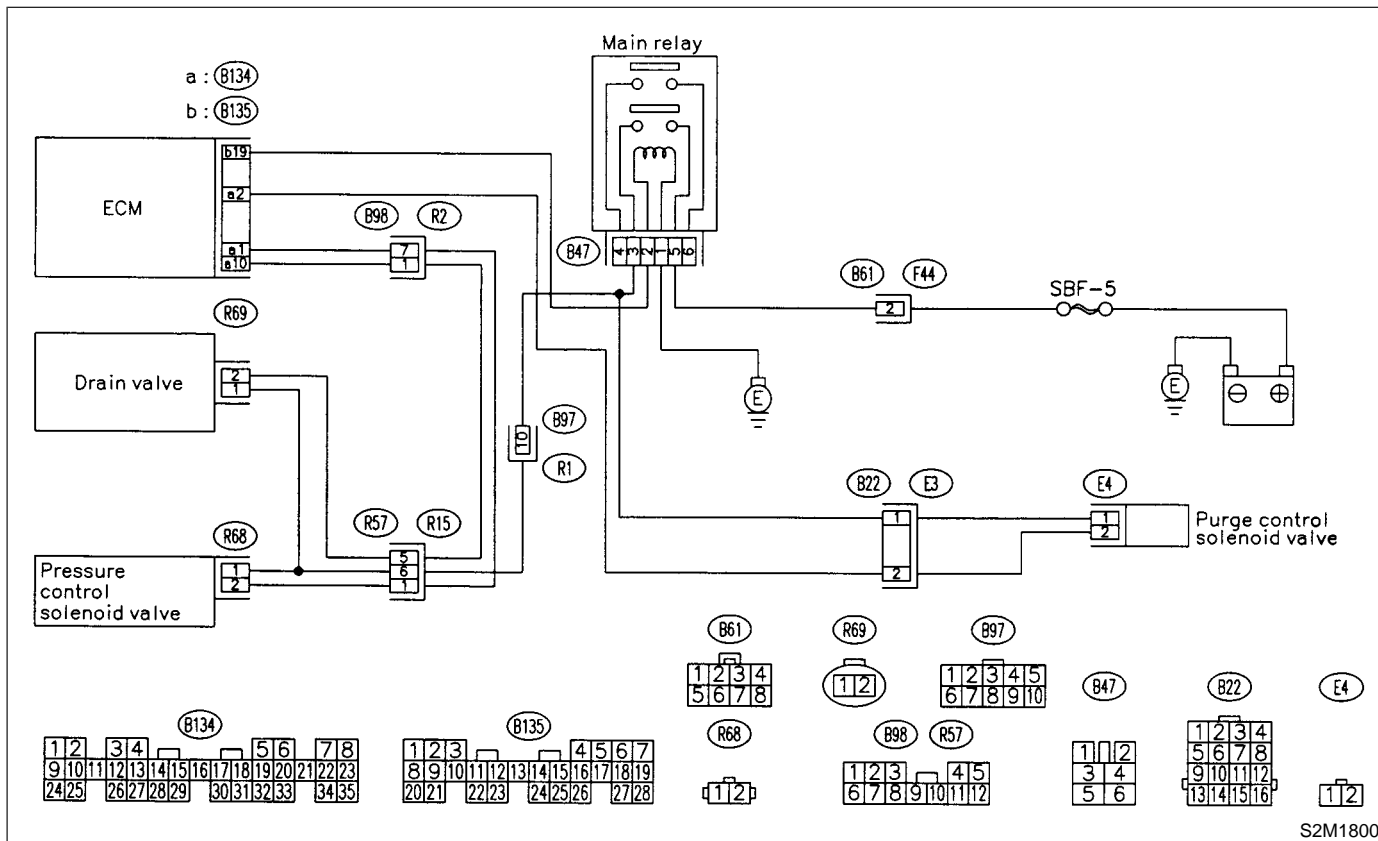

**10AH1 : CHECK ANY OTHER DTC ON DISPLAY.**

- CHECK** : *Is there any other DTC on display?*
- YES** : Inspect the relevant DTC using "10. Diagnostics Chart with Trouble Code". <Ref. to 2-7 [T10A0].>
- NO** : Go to step **10AH2**.

**10AH2 : CHECK FUEL FILLER CAP.**

- 1) Turn ignition switch to OFF.
- 2) Check the fuel filler cap.

**NOTE:**  
The DTC code is stored in memory if fuel filler cap is or was loose or if the cap chain was caught while tightening.

- CHECK** : *Is the fuel filler cap tightened securely?*
- YES** : Go to step **10AH3**.
- NO** : Tighten fuel filler cap securely.

**10AH3 : CHECK FUEL FILLER PIPE PACKING.**

- CHECK** : *Is there any damage to the seal between fuel filler cap and fuel filler pipe?*
- YES** : Repair or replace fuel filler cap and fuel filler pipe. <Ref. to 2-8 [W2A0].>
- NO** : Go to step **10AH4**.

**10AH4 : CHECK DRAIN VALVE.**

1) Connect test mode connector.

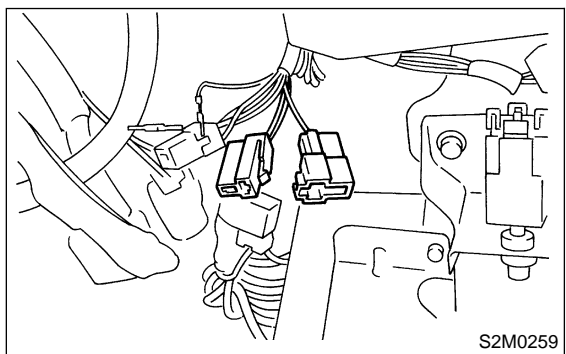

- 2) Turn ignition switch to ON.
- 3) Operate drain valve.

**NOTE:**  
 Drain valve operation can also be executed using Subaru Select Monitor. For the procedure, refer to "COMPULSORY VALVE OPERATION CHECK MODE". <Ref. to 2-7 [T3F0].>

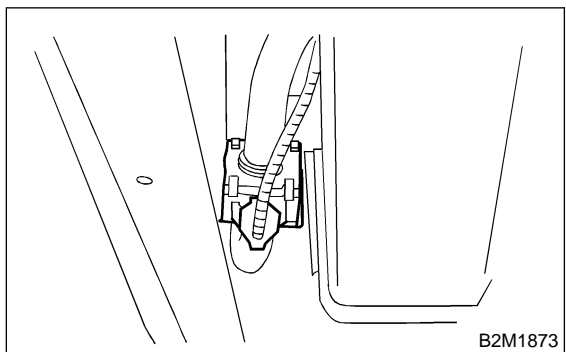

- CHECK** : *Does drain valve produce operating sound?*
- YES** : Go to step **10AH5**.
- NO** : Replace drain valve. <Ref. to 2-1 [W13A0].>

**10AH5 : CHECK PURGE CONTROL SOLENOID VALVE.**

Operate purge control solenoid valve.

**NOTE:**  
 Purge control solenoid valve operation can also be executed using Subaru Select Monitor. For the procedure, refer to "COMPULSORY VALVE OPERATION CHECK MODE". <Ref. to 2-7 [T3F0].>

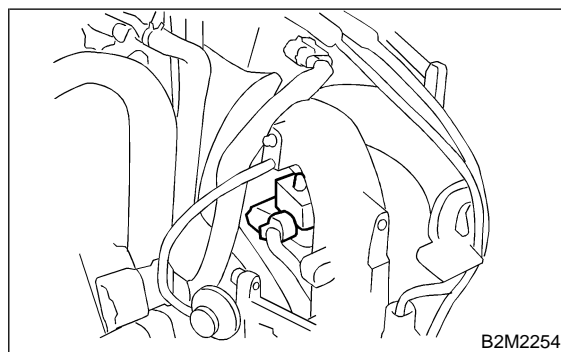

- CHECK** : *Does purge control solenoid valve produce operating sound?*
- YES** : Go to step **10AH6**.
- NO** : Replace purge control solenoid valve. <Ref. to 2-1 [W4A0].>



**10AH6 : CHECK PRESSURE CONTROL SOLENOID VALVE.**

Operate pressure control solenoid valve.

**NOTE:**

Pressure control solenoid valve operation can also be executed using Subaru Select Monitor. For the procedure, refer to "COMPULSORY VALVE OPERATION CHECK MODE". <Ref. to 2-7 [T3F0].>

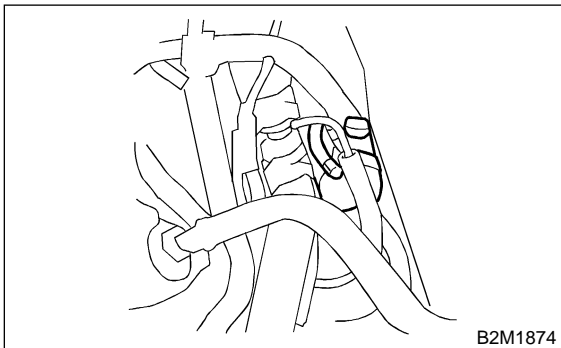

- CHECK** : **Does pressure control solenoid valve produce operating sound?**
- YES** : Go to step **10AH7**.
- NO** : Replace pressure control solenoid valve. <Ref. to 2-1 [W9A0].>

**10AH7 : CHECK EVAPORATIVE EMISSION CONTROL SYSTEM LINE.**

Turn ignition switch to OFF.

- CHECK** : **Is there a hole of more than 0.5 mm (0.020 in) dia. on fuel line?**
- YES** : Repair or replace fuel line. <Ref. to 2-8 [W8A0].>
- NO** : Go to step **10AH8**.

**10AH8 : CHECK CANISTER.**

- CHECK** : **Is canister damaged or is there a hole of more than 0.5 mm (0.020 in) dia. in it?**
- YES** : Repair or replace canister. <Ref. to 2-1 [W3A0].>
- NO** : Go to step **10AH9**.

**10AH9 : CHECK FUEL TANK.**

Remove fuel tank. <Ref. to 2-8 [W1C0].>

- CHECK** : **Is fuel tank damaged or is there a hole of more than 0.5 mm (0.020 in) dia. in it?**
- YES** : Repair or replace fuel tank. <Ref. to 2-8 [W1C0].>
- NO** : Go to step **10AH10**.

**10AH10 : CHECK ANY OTHER MECHANICAL TROUBLE IN EVAPORATIVE EMISSION CONTROL SYSTEM.**

- CHECK** : **Are there holes of more than 0.5 mm (0.020 in) dia., cracks, clogging or disconnections of hoses or pipes in evaporative emission control system?**
- YES** : Repair or replace hoses or pipes.
- NO** : Contact with SOA service.

**NOTE:**

Inspection by DTM is required, because probable cause is deterioration of multiple parts.

**MEMO:**

**AI: DTC P0443 — EVAPORATIVE EMISSION CONTROL SYSTEM PURGE CONTROL VALVE CIRCUIT LOW INPUT —**

- **DTC DETECTING CONDITION:**
  - Two consecutive driving cycles with fault
- **TROUBLE SYMPTOM:**
  - Erroneous idling

**CAUTION:**

After repair or replacement of faulty parts, conduct CLEAR MEMORY MODE <Ref. to 2-7 [T3D0].> and INSPECTION MODE <Ref. to 2-7 [T3E0].>

● **WIRING DIAGRAM:**

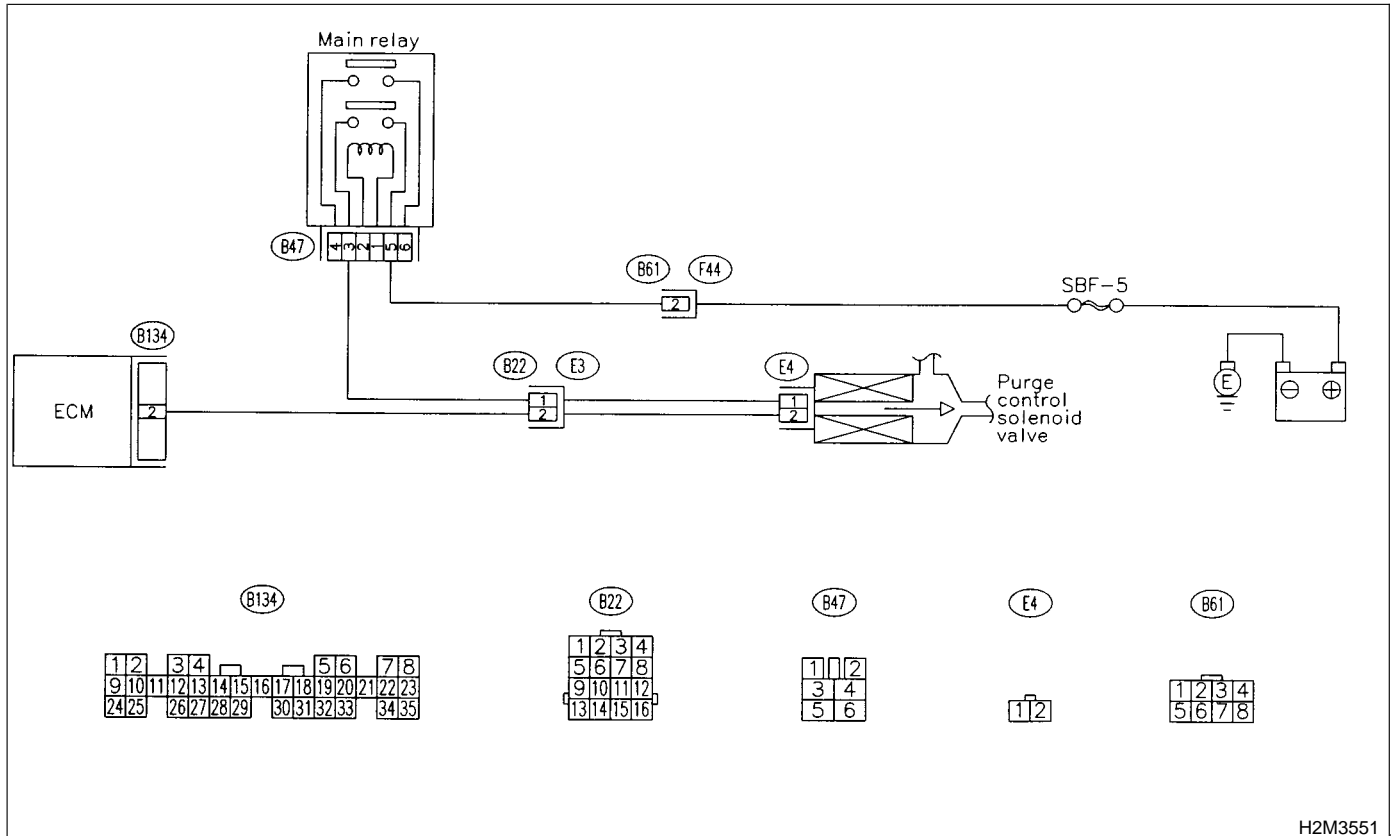

H2M3551

**10A11 : CHECK OUTPUT SIGNAL FROM ECM.**

- 1) Turn ignition switch to ON.
- 2) Measure voltage between ECM and chassis ground.

**Connector & terminal**

**(B134) No. 2 (+) — Chassis ground (-):**

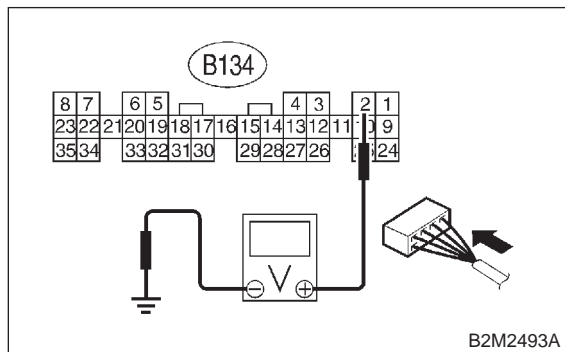

- CHECK** : **Is the voltage more than 10 V?**
- YES** : Even if MIL lights up, the circuit has returned to a normal condition at this time. Contact with SOA service.

**NOTE:**

Inspection by DTM is required, because probable cause is deterioration of multiple parts.

- NO** : Go to step **10A12**.

**10A12 : CHECK HARNESS BETWEEN PURGE CONTROL SOLENOID VALVE AND ECM CONNECTOR.**

- 1) Turn ignition switch to OFF.
- 2) Disconnect connectors from purge control solenoid valve and ECM.
- 3) Measure resistance of harness between purge control solenoid valve connector and engine ground.

**Connector & terminal**

**(E4) No. 2 — Engine ground:**

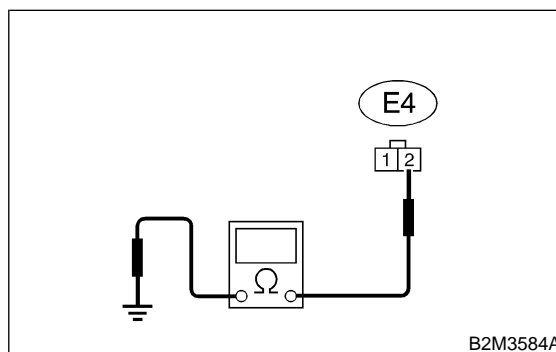

- CHECK** : **Is the resistance less than 10 Ω?**
- YES** : Repair ground short circuit in harness between ECM and purge control solenoid valve connector.
- NO** : Go to step **10A13**.

**10AI3 : CHECK HARNESS BETWEEN PURGE CONTROL SOLENOID VALVE AND ECM CONNECTOR.**

Measure resistance of harness between ECM and purge control solenoid valve of harness connector.

**Connector & terminal**

**(B134) No. 2 — (E4) No. 2:**

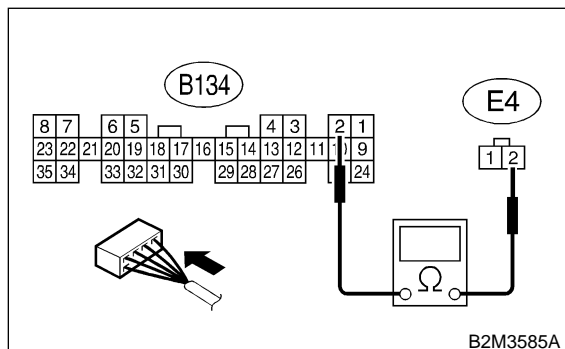

**CHECK** : **Is the resistance less than 1 Ω?**

**YES** : Go to step **10AI4**.

**NO** : Repair open circuit in harness between ECM and purge control solenoid valve connector.

**NOTE:**

In this case, repair the following:

- Open circuit in harness between ECM and purge control solenoid valve connector
- Poor contact in coupling connector (B22)

**10AI4 : CHECK PURGE CONTROL SOLENOID VALVE.**

- 1) Remove purge control solenoid valve.
- 2) Measure resistance between purge control solenoid valve terminals.

**Terminals**

**No. 1 — No. 2:**

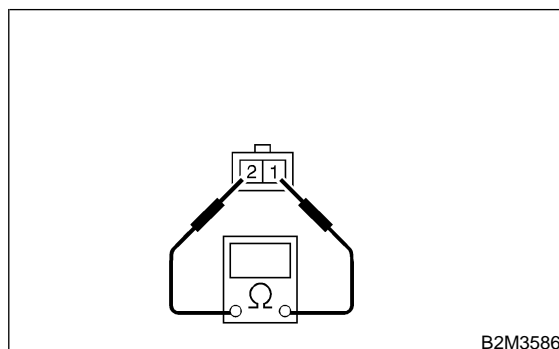

**CHECK** : **Is the resistance between 10 and 100 Ω?**

**YES** : Go to step **10AI5**.

**NO** : Replace purge control solenoid valve. <Ref. to 2-1 [W4A0].>

**10AI5 : CHECK MAIN RELAY.**

- 1) Turn the ignition switch to OFF.
- 2) Remove main relay.
- 3) Connect battery to main relay terminals No. 1 and No. 2.
- 4) Measure resistance between main relay terminals.

**Terminals**

**No. 3 — No. 5:**

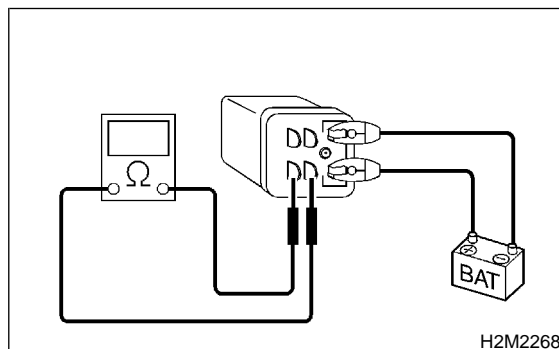

**CHECK** : **Is the resistance less than 10 Ω?**

**YES** : Go to step **10AI6**.

**NO** : Replace main relay.

**10A16 : CHECK POWER SUPPLY TO PURGE CONTROL SOLENOID VALVE.**

- 1) Turn ignition switch to ON.
- 2) Measure voltage between purge control solenoid valve and engine ground.

**Connector & terminal**

**(E4) No. 1 (+) — Engine ground (-):**

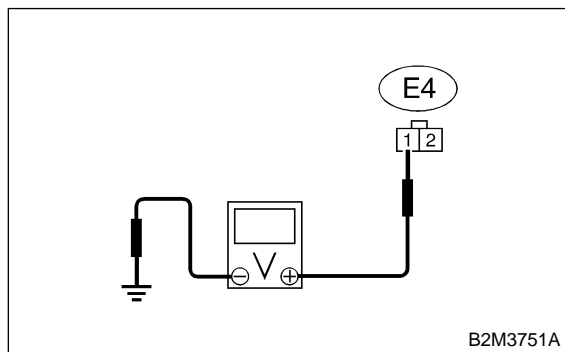

- CHECK** : **Is the voltage more than 10 V?**
- YES** : Go to step **10A17**.
- NO** : Repair open circuit in harness between battery and purge control solenoid valve connector.

**10A17 : CHECK POOR CONTACT.**

Check poor contact in purge control solenoid valve connector. <Ref. to FOREWORD [T3C1].>

- CHECK** : **Is there poor contact in purge control solenoid valve connector?**
- YES** : Repair poor contact in purge control solenoid valve connector.
- NO** : Contact with SOA service.

**NOTE:**

Inspection by DTM is required, because probable cause is deterioration of multiple parts.

### AJ: DTC P0446 — EVAPORATIVE EMISSION CONTROL SYSTEM VENT CONTROL LOW INPUT —

● DTC DETECTING CONDITION:

- Two consecutive driving cycles with fault

**CAUTION:**

After repair or replacement of faulty parts, conduct CLEAR MEMORY MODE <Ref. to 2-7 [T3D0].> and INSPECTION MODE <Ref. to 2-7 [T3E0].>

● WIRING DIAGRAM:

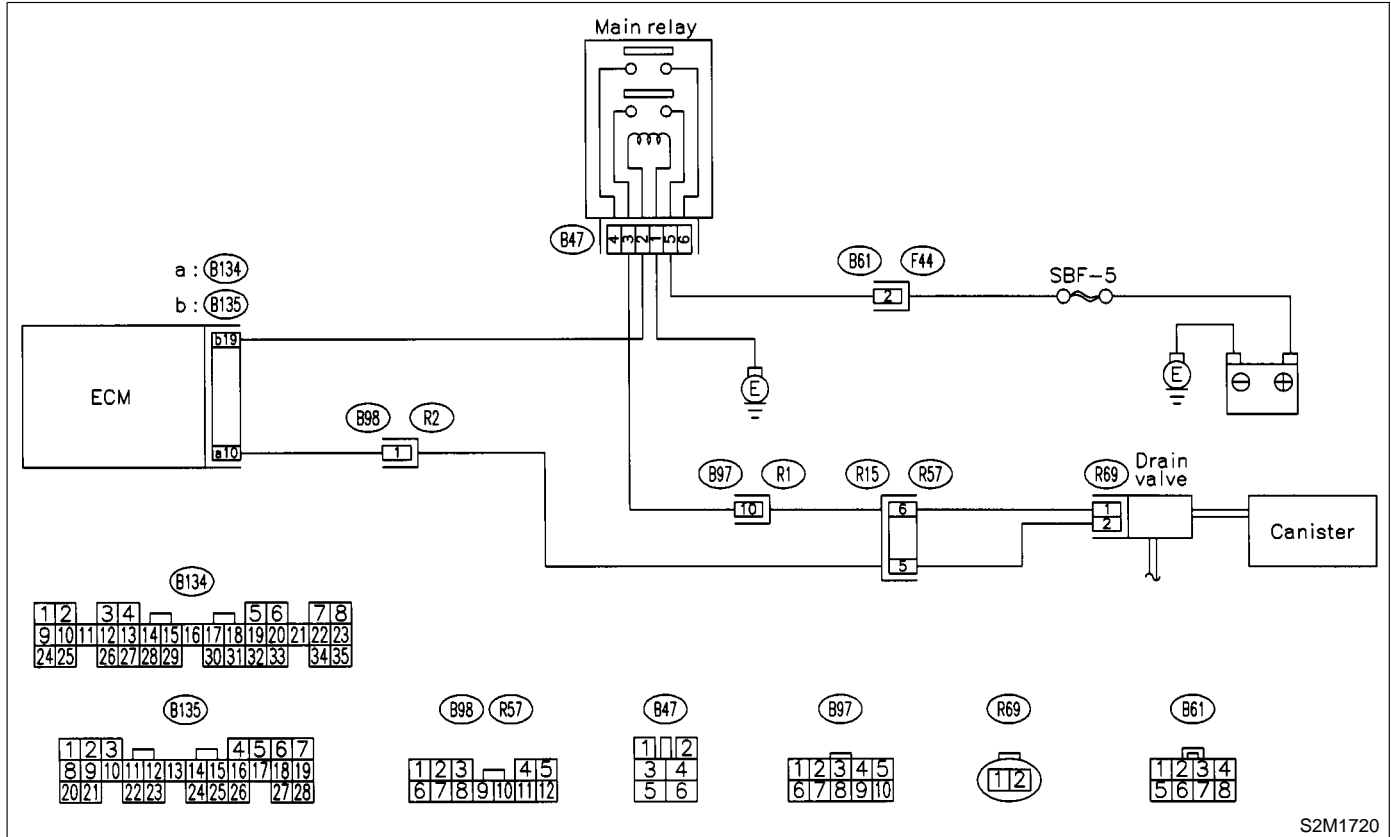

S2M1720

**10AJ1 : CHECK OUTPUT SIGNAL FROM ECM.**

- 1) Turn ignition switch to ON.
- 2) Measure voltage between ECM and chassis ground.

**Connector & terminal**

**(B134) No. 10 (+) — Chassis ground (-):**

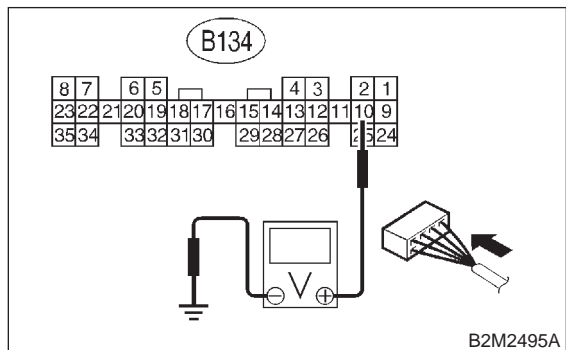

- CHECK** : *Is the voltage more than 10 V?*
- YES** : Go to step **10AJ2**.
- NO** : Go to step **10AJ3**.

**10AJ2 : CHECK POOR CONTACT.**

Check poor contact in ECM connector. <Ref. to FOREWORD [T3C1].>

- CHECK** : *Is there poor contact in ECM connector?*
- YES** : Repair poor contact in ECM connector.
- NO** : Even if MIL lights up, the circuit has returned to a normal condition at this time. (However, the possibility of poor contact still remains.)

**NOTE:**

In this case, repair the following:

- Poor contact in drain valve connector
- Poor contact in ECM connector
- Poor contact in coupling connectors (B98 and R57)

**10AJ3 : CHECK HARNESS BETWEEN DRAIN VALVE AND ECM CONNECTOR.**

- 1) Turn ignition switch to OFF.
- 2) Disconnect connectors from drain valve and ECM.
- 3) Measure resistance of harness between drain valve connector and chassis ground.

**Connector & terminal**

**(R69) No. 2 — Chassis ground:**

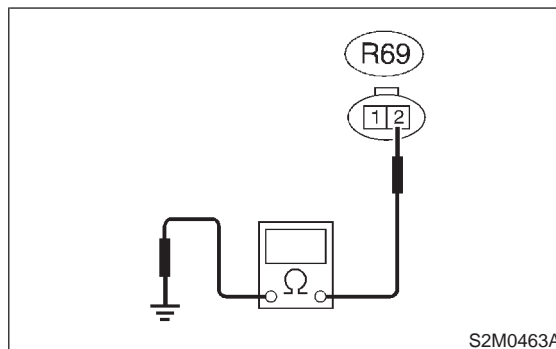

- CHECK** : *Is the resistance less than 10 Ω?*
- YES** : Repair ground short circuit in harness between ECM and drain valve connector.
- NO** : Go to step **10AJ4**.



**10AJ4 : CHECK HARNESS BETWEEN DRAIN VALVE AND ECM CONNECTOR.**

Measure resistance of harness between ECM and drain valve connector.

**Connector & terminal**

**(B134) No. 10 — (R69) No. 2:**

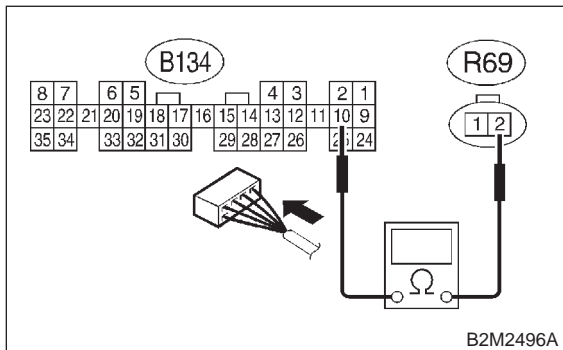

**CHECK** : *Is the voltage less than 1 Ω?*

**YES** : Go to step **10AJ5**.

**NO** : Repair harness and connector.

**NOTE:**

In this case, repair the following:

- Open circuit in harness between ECM and drain valve connector
- Poor contact in coupling connectors (B98 and R57)

**10AJ5 : CHECK DRAIN VALVE.**

Measure resistance between drain valve terminals.

**Terminals**

**No. 1 — No. 2:**

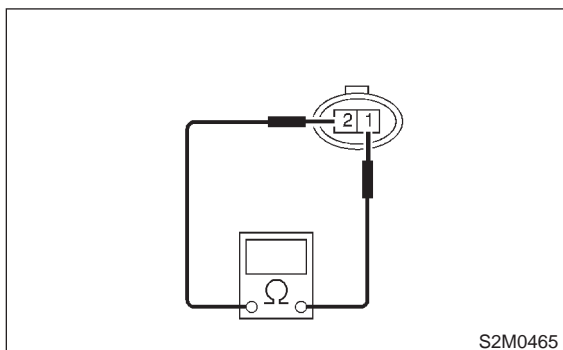

**CHECK** : *Is the resistance between 10 and 100 Ω?*

**YES** : Go to step **10AJ6**.

**NO** : Replace drain valve. <Ref. to 2-1 [W13A0].>

**10AJ6 : CHECK MAIN RELAY.**

- 1) Turn the ignition switch to OFF.
- 2) Remove main relay.
- 3) Connect battery to main relay terminals No. 1 and No. 2.
- 4) Measure resistance between main relay terminals.

**Terminals**

**No. 3 — No. 5:**

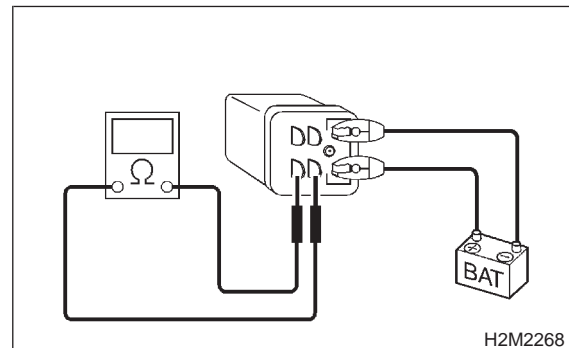

**CHECK** : *Is the resistance less than 10 Ω?*

**YES** : Go to step **10AJ7**.

**NO** : Replace main relay.

**10AJ7 : CHECK POWER SUPPLY TO DRAIN VALVE.**

- 1) Turn ignition switch to ON.
- 2) Measure voltage between drain valve and chassis ground.

**Connector & terminal**

**(R69) No. 1 (+) — Chassis ground (-):**

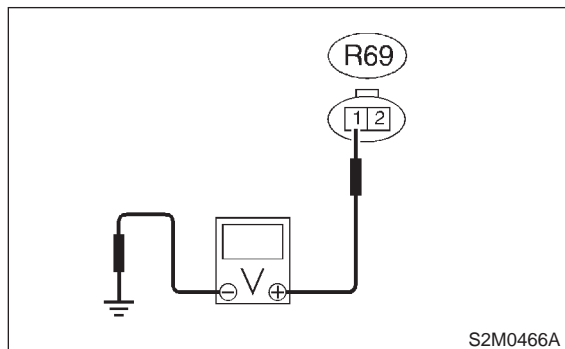

**CHECK** : **Is the voltage more than 10 V?**

**YES** : Go to step **10AJ8**.

**NO** : Repair harness and connector.

**NOTE:**

In this case, repair the following:

- Open circuit in harness between battery and drain valve
- Poor contact in coupling connectors (B97 and R57)
- Poor contact in main relay connector

**10AJ8 : CHECK POOR CONTACT.**

Check poor contact in drain valve connector. <Ref. to FOREWORD [T3C1].>

**CHECK** : **Is there poor contact in drain valve connector?**

**YES** : Repair poor contact in drain valve connector.

**NO** : Contact with SOA service.

**NOTE:**

Inspection by DTM is required, because probable cause is deterioration of multiple parts.

**AK: DTC P0451 — EVAPORATIVE EMISSION CONTROL SYSTEM PRESSURE SENSOR RANGE/PERFORMANCE PROBLEM —**

**● DTC DETECTING CONDITION:**

- Two consecutive driving cycles with fault

**CAUTION:**

After repair or replacement of faulty parts, conduct CLEAR MEMORY MODE <Ref. to 2-7 [T3D0].> and INSPECTION MODE <Ref. to 2-7 [T3E0].>

**● WIRING DIAGRAM:**

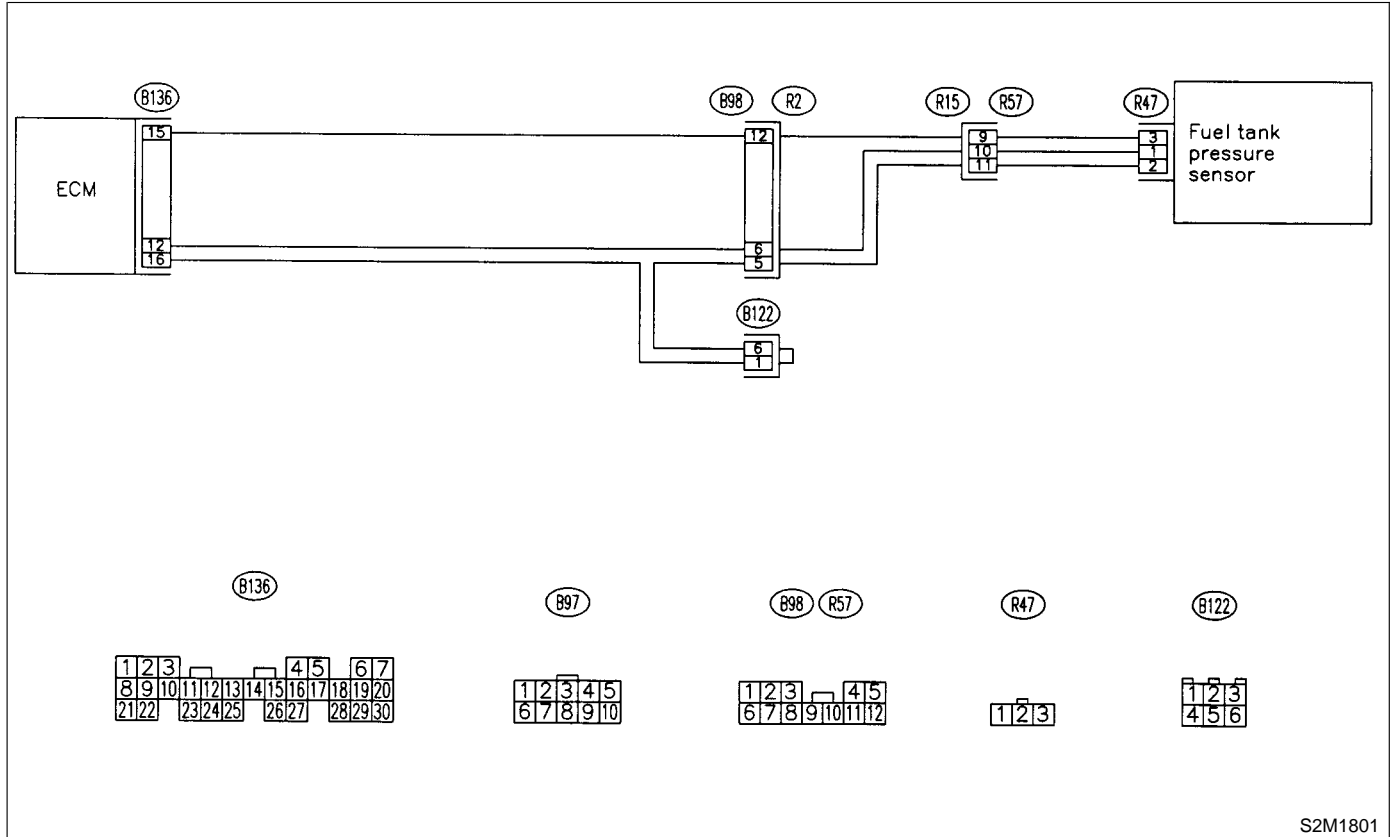

S2M1801

**10AK1 : CHECK ANY OTHER DTC ON DISPLAY.**

- CHECK** : *Is there any DTC on display?*
- YES** : Inspect the relevant DTC using "10. Diagnostics Chart with Trouble Code". <Ref. to 2-7 [T10A0].>
- NO** : Go to step **10AK2**.

**10AK2 : CHECK FUEL FILLER CAP.**

- 1) Turn ignition switch to OFF.
  - 2) Open the fuel flap.
- CHECK** : *Is the fuel filler cap tightened securely?*
  - YES** : Go to step **10AK3**.
  - NO** : Tighten fuel filler cap securely.

**10AK3 : CHECK PRESSURE/VACUUM LINE.**

- NOTE:**  
Check the following items.
- Disconnection, leakage and clogging of the vacuum hoses and pipes between fuel tank pressure sensor and fuel tank
  - Disconnection, leakage and clogging of air ventilation hoses and pipes between fuel filler pipe and fuel tank
- CHECK** : *Is there a fault in pressure/vacuum line?*
  - YES** : Repair or replace hoses and pipes.
  - NO** : Replace fuel tank pressure sensor. <Ref. to 2-1 [W8A0].>

MEMO:

**AL: DTC P0452 — EVAPORATIVE EMISSION CONTROL SYSTEM PRESSURE SENSOR LOW INPUT —**

- **DTC DETECTING CONDITION:**
  - Immediately at fault recognition

**CAUTION:**

After repair or replacement of faulty parts, conduct CLEAR MEMORY MODE <Ref. to 2-7 [T3D0].> and INSPECTION MODE <Ref. to 2-7 [T3E0].>

- **WIRING DIAGRAM:**

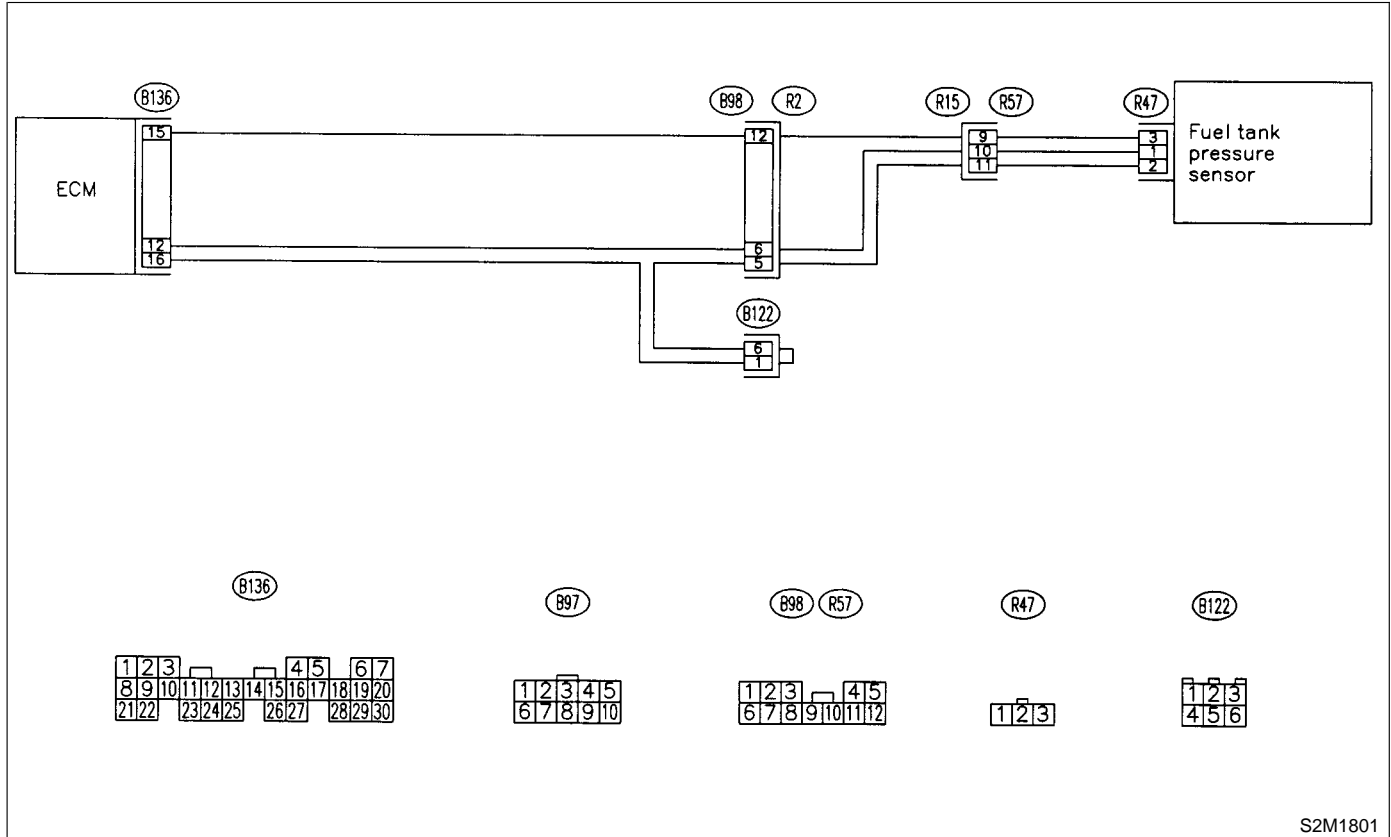

S2M1801

**10AL1 : CHECK CURRENT DATA.**

- 1) Turn ignition switch to OFF.
- 2) Remove fuel filler cap.
- 3) Install fuel filler cap.
- 4) Turn ignition switch to ON.
- 5) Read the data of fuel tank pressure sensor signal using Subaru Select Monitor or the OBD-II general scan tool.

**NOTE:**

- Subaru Select Monitor  
For detailed operation procedure, refer to the "READ CURRENT DATA SHOWN ON DISPLAY FOR ENGINE". <Ref. to 2-7 [T3C4].>
- OBD-II general scan tool  
For detailed operation procedures, refer to the OBD-II General Scan Tool Instruction Manual.

- CHECK** : *Is the value less than -2.8 kPa (-21.0 mmHg, -0.827 inHg)?*
- YES** : Go to step **10AL2**.
- NO** : Even if MIL lights up, the circuit has returned to a normal condition at this time.

**10AL2 : CHECK POWER SUPPLY TO FUEL TANK PRESSURE SENSOR.**

Measure voltage between ECM connector and chassis ground.

**Connector & terminal**  
**(B136) No. 15 (+) — Chassis ground (-):**

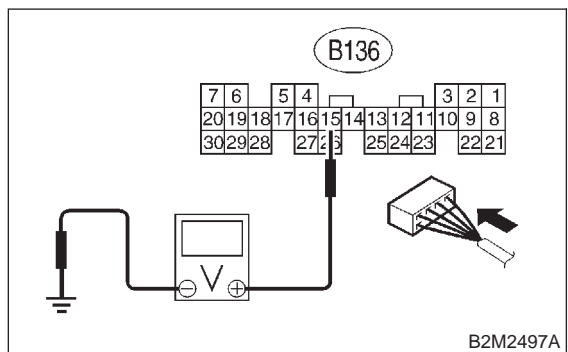

- CHECK** : *Is the voltage more than 4.5 V?*
- YES** : Go to step **10AL4**.
- NO** : Go to step **10AL3**.

**10AL3 : CHECK POWER SUPPLY TO FUEL TANK PRESSURE SENSOR.**

Measure voltage between ECM connector and chassis ground.

**Connector & terminal**  
**(B136) No. 15 (+) — Chassis ground (-):**

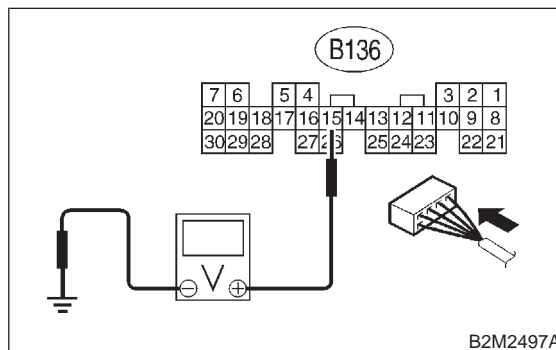

- CHECK** : *Does the voltage change more than 4.5 V by shaking harness and connector of ECM while monitoring the value with voltage meter?*
- YES** : Repair poor contact in ECM connector.
- NO** : Contact with SOA service.

**NOTE:**

Inspection by DTM is required, because probable cause is deterioration of multiple parts.

**10AL4 : CHECK INPUT SIGNAL FOR ECM.**

Measure voltage between ECM and chassis ground.

**Connector & terminal**  
**(B136) No. 12 (+) — Chassis ground (-):**

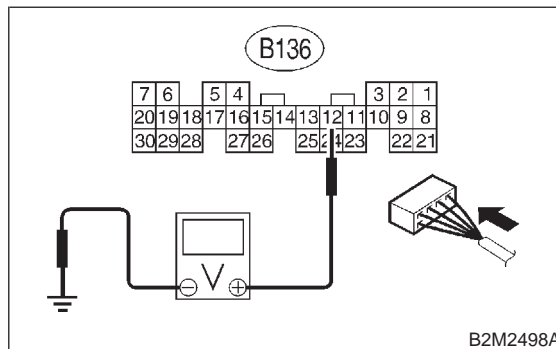

- CHECK** : *Is the voltage less than 0.2 V?*
- YES** : Go to step **10AL6**.
- NO** : Go to step **10AL5**.

**10AL5 : CHECK INPUT SIGNAL FOR ECM. (USING SUBARU SELECT MONITOR.)**

Read data of fuel tank pressure sensor signal using Subaru Select Monitor.

**NOTE:**

- Subaru Select Monitor

For detailed operation procedure, refer to the "READ CURRENT DATA SHOWN ON DISPLAY FOR ENGINE". <Ref. to 2-7 [T3C4].>

**CHECK** : Does the value change more than **-2.8 kPa (-21.0 mmHg, -0.827 inHg)** by shaking harness and connector of ECM while monitoring the value with Subaru Select Monitor?

- YES** : Repair poor contact in ECM connector.
- NO** : Go to step **10AL6**.

**10AL6 : CHECK HARNESS BETWEEN ECM AND COUPLING CONNECTOR IN REAR WIRING HARNESS.**

- 1) Turn ignition switch to OFF.
- 2) Remove rear seat cushion (Wagon).
- 3) Separate rear wiring harness and fuel tank cord.
- 4) Turn ignition switch to ON.
- 5) Measure voltage between rear wiring harness connector and chassis ground.

**Connector & terminal**

**(R15) No. 9 (+) — Chassis ground (-):**

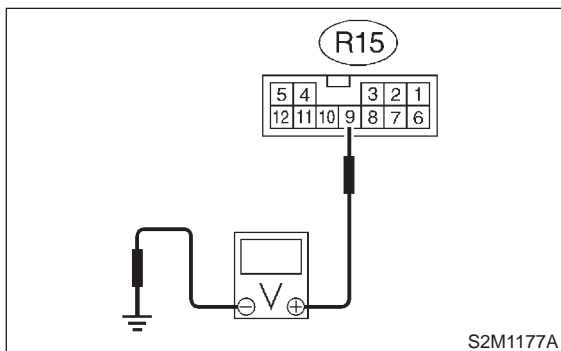

- CHECK** : Is the voltage more than **4.5 V**?
- YES** : Go to step **10AL7**.
- NO** : Repair harness and connector.

**NOTE:**

In this case, repair the following:

- Open circuit in harness between ECM and rear wiring harness connector (R15)
- Poor contact in coupling connector (B98)

**10AL7 : CHECK HARNESS BETWEEN ECM AND COUPLING CONNECTOR IN REAR WIRING HARNESS.**

- 1) Turn ignition switch to OFF.
- 2) Disconnect connector from ECM.
- 3) Measure resistance of harness between ECM and rear wiring harness connector.

**Connector & terminal**

**(B136) No. 16 — (R15) No. 11:**

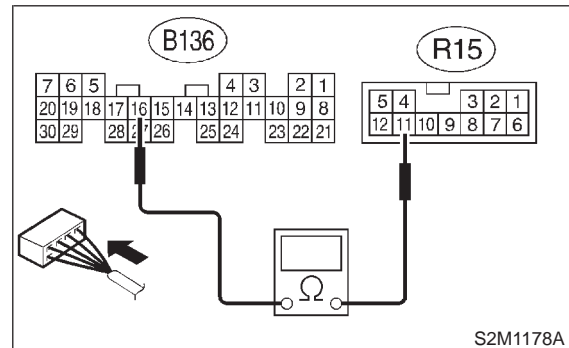

- CHECK** : Is the resistance less than **1 Ω**?
- YES** : Go to step **10AL8**.
- NO** : Repair harness and connector.

**NOTE:**

In this case, repair the following:

- Open circuit in harness between ECM and rear wiring harness connector (R15)
- Poor contact in coupling connector (B98)
- Poor contact in joint connector (B122)

**10AL8 : CHECK HARNESS BETWEEN ECM AND COUPLING CONNECTOR IN REAR WIRING HARNESS.**

Measure resistance of harness between rear wiring harness connector and chassis ground.

**Connector & terminal**

**(R15) No. 11 — Chassis ground:**

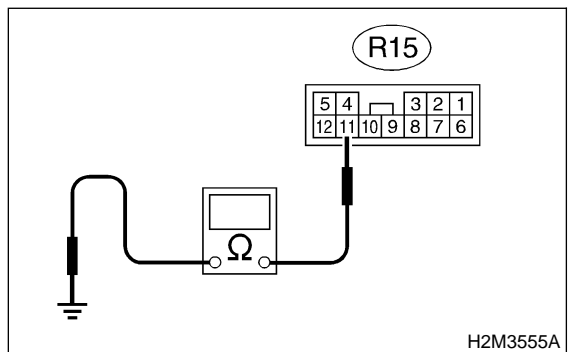

- CHECK** : **Is the resistance more than 500 kΩ?**
- YES** : Go to step **10AL9**.
- NO** : Repair ground short circuit in harness between ECM and rear wiring harness connector (R15).

**10AL9 : CHECK FUEL TANK CORD.**

- 1) Disconnect connector from fuel tank pressure sensor.
- 2) Measure resistance of fuel tank cord.

**Connector & terminal**

**(R57) No. 9 — (R47) No. 3:**

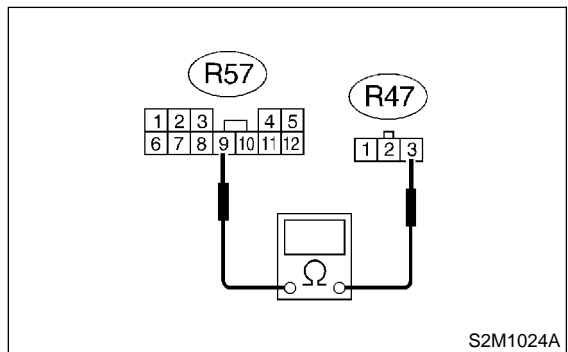

- CHECK** : **Is the resistance less than 1 Ω?**
- YES** : Go to step **10AL10**.
- NO** : Repair open circuit in fuel tank cord.

**10AL10 : CHECK FUEL TANK CORD.**

Measure resistance of fuel tank cord.

**Connector & terminal**

**(R57) No. 10 — (R47) No. 1:**

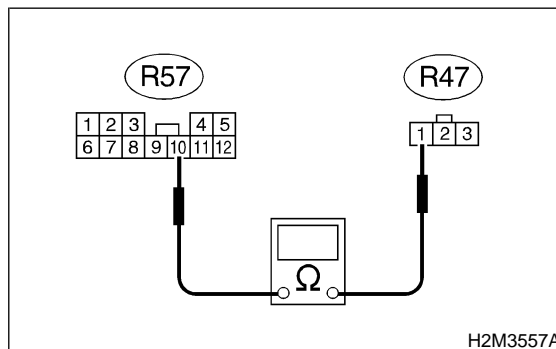

- CHECK** : **Is the resistance less than 1 Ω?**
- YES** : Go to step **10AL11**.
- NO** : Repair open circuit in fuel tank cord.

**10AL11 : CHECK FUEL TANK CORD.**

Measure resistance of harness between fuel tank pressure sensor connector and chassis ground.

**Connector & terminal**

**(R47) No. 2 — Chassis ground:**

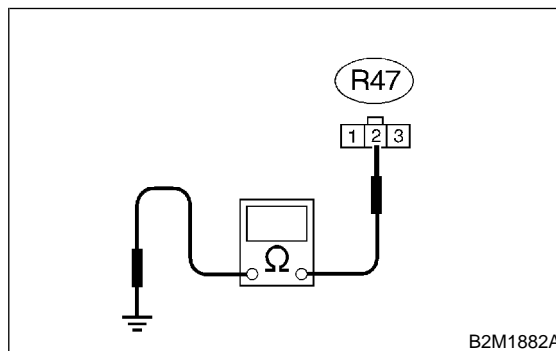

- CHECK** : **Is the resistance more than 500 kΩ?**
- YES** : Go to step **10AL12**.
- NO** : Repair ground short circuit in fuel tank cord.



**10AL12 : CHECK POOR CONTACT.**

Check poor contact in fuel tank pressure sensor connector. <Ref. to FOREWORD [T3C1].>

- CHECK** : *Is there poor contact in fuel tank pressure sensor connector?*
- YES** : Repair poor contact in fuel tank pressure sensor connector.
- NO** : Replace fuel tank pressure sensor. <Ref. to 2-1 [W8A0].>

**MEMO:**

**AM: DTC P0453 — EVAPORATIVE EMISSION CONTROL SYSTEM PRESSURE SENSOR HIGH INPUT —**

- **DTC DETECTING CONDITION:**
  - Immediately at fault recognition

**CAUTION:**

After repair or replacement of faulty parts, conduct CLEAR MEMORY MODE <Ref. to 2-7 [T3D0].> and INSPECTION MODE <Ref. to 2-7 [T3E0].>

- **WIRING DIAGRAM:**

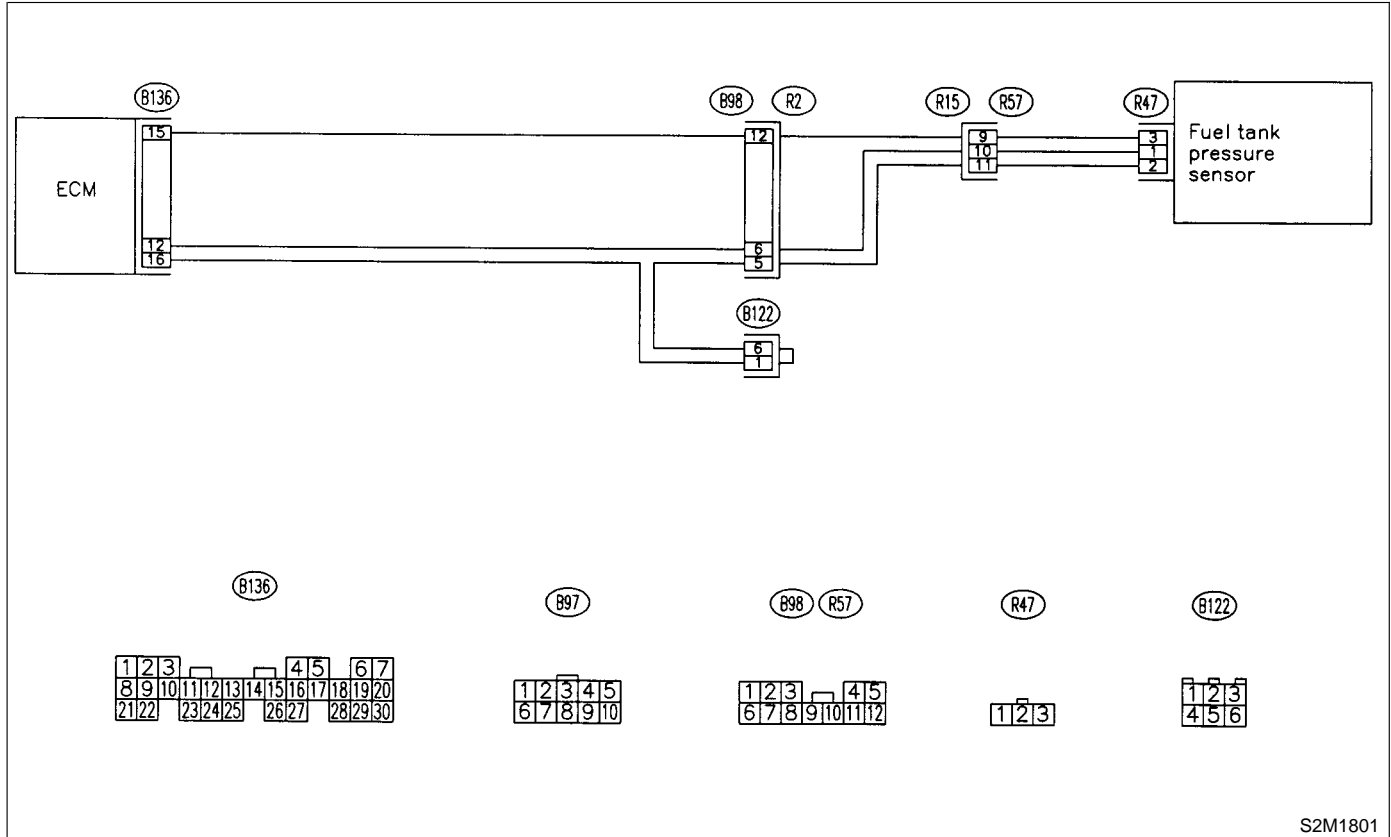

S2M1801

**10AM1 : CHECK CURRENT DATA.**

- 1) Turn ignition switch to OFF.
- 2) Remove fuel filler cap.
- 3) Install fuel filler cap.
- 4) Turn ignition switch to ON.
- 5) Read data of fuel tank pressure sensor signal using Subaru Select Monitor or OBD-II general scan tool.

**NOTE:**

- Subaru Select Monitor  
For detailed operation procedure, refer to the "READ CURRENT DATA SHOWN ON DISPLAY FOR ENGINE". <Ref. to 2-7 [T3C4].>
- OBD-II general scan tool  
For detailed operation procedures, refer to the OBD-II General Scan Tool Instruction Manual.

- CHECK** : *Is the value more than 2.8 kPa (21.0 mmHg, 0.827 inHg)?*
- YES** : Go to step **10AM12**.
- NO** : Go to step **10AM2**.

**10AM2 : CHECK POWER SUPPLY TO FUEL TANK PRESSURE SENSOR.**

Measure voltage between ECM connector and chassis ground.

**Connector & terminal**  
**(B136) No. 15 (+) — Chassis ground (-):**

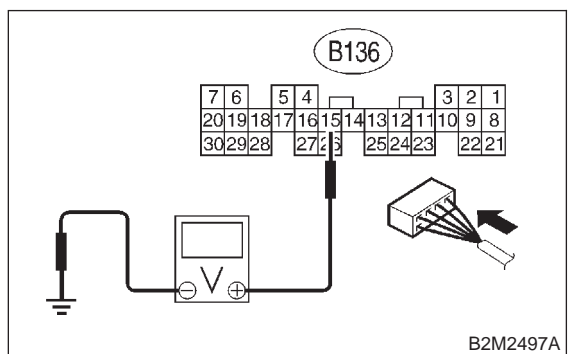

- CHECK** : *Is the voltage more than 4.5 V?*
- YES** : Go to step **10AM4**.
- NO** : Go to step **10AM3**.

**10AM3 : CHECK POWER SUPPLY TO FUEL TANK PRESSURE SENSOR.**

Measure voltage between ECM connector and chassis ground.

**Connector & terminal**  
**(B136) No. 15 (+) — Chassis ground (-):**

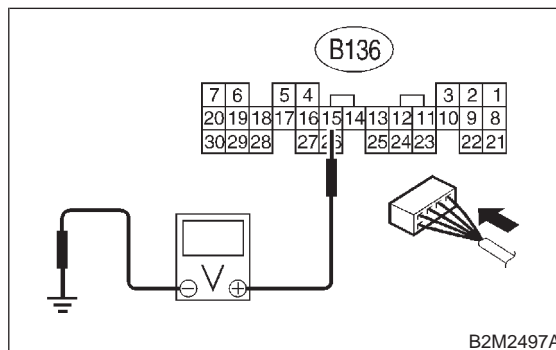

- CHECK** : *Does the voltage change more than 4.5 V by shaking harness and connector of ECM while monitoring the value with voltage meter?*
- YES** : Repair poor contact in ECM connector.
- NO** : Replace ECM. <Ref. to 2-7 [W17A0].>

**10AM4 : CHECK INPUT SIGNAL FOR ECM.**

Measure voltage between ECM and chassis ground.

**Connector & terminal**  
**(B136) No. 12 (+) — Chassis ground (-):**

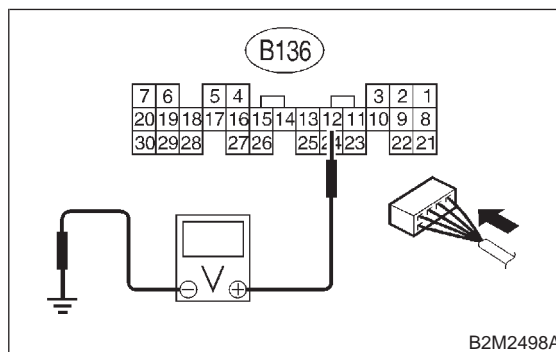

- CHECK** : *Is the voltage less than 0.2 V?*
- YES** : Go to step **10AM6**.
- NO** : Go to step **10AM5**.

**10AM5 : CHECK INPUT SIGNAL FOR ECM.  
(USING SUBARU SELECT MONI-  
TOR.)**

Read data of fuel tank pressure sensor signal using Subaru Select Monitor.

**NOTE:**

- Subaru Select Monitor

For detailed operation procedure, refer to the "READ CURRENT DATA SHOWN ON DISPLAY FOR ENGINE". <Ref. to 2-7 [T3C4].>

**CHECK** : *Does the value change more than  $-2.8$  kPa ( $-21.0$  mmHg,  $-0.827$  inHg) by shaking harness and connector of ECM while monitoring the value with Subaru Select Monitor?*

**YES** : Repair poor contact in ECM connector.

**NO** : Go to step 10AM6.

**10AM6 : CHECK HARNESS BETWEEN  
ECM AND COUPLING CONNec-  
TOR IN REAR WIRING HARNESS.**

- 1) Turn ignition switch to OFF.
- 2) Remove rear seat cushion (Sedan) or move rear seat cushion (Wagon).
- 3) Separate rear wiring harness and fuel tank cord.
- 4) Turn ignition switch to ON.
- 5) Measure voltage between rear wiring harness connector and chassis ground.

**Connector & terminal**

**(R15) No. 9 (+) — Chassis ground (-):**

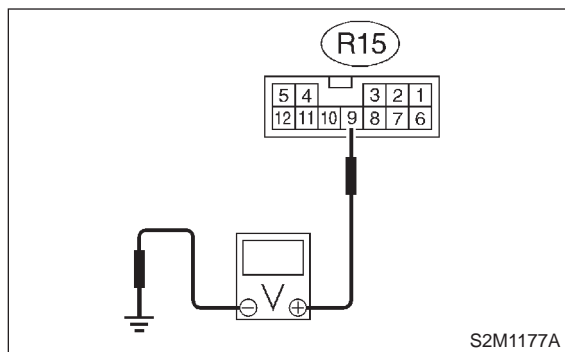

**CHECK** : *Is the voltage more than 4.5 V?*

**YES** : Go to step 10AM7.

**NO** : Repair harness and connector.

**NOTE:**

In this case, repair the following:

- Open circuit in harness between ECM and rear wiring harness connector (R15)
- Poor contact in coupling connector (B98)

**10AM7 : CHECK HARNESS BETWEEN  
ECM AND COUPLING CONNec-  
TOR IN REAR WIRING HARNESS.**

- 1) Turn ignition switch to OFF.
- 2) Disconnect connector from ECM.
- 3) Measure resistance of harness between ECM and rear wiring harness connector.

**Connector & terminal**

**(B136) No. 12 — (R15) No. 10:**

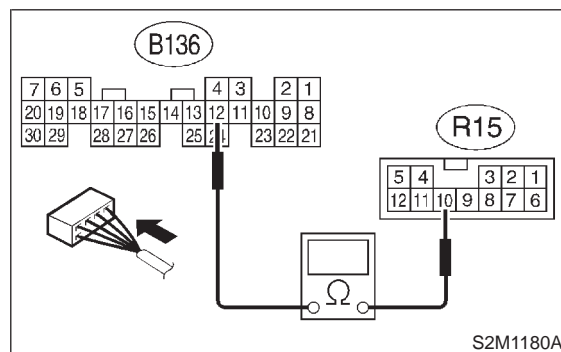

**CHECK** : *Is the resistance less than 1  $\Omega$ ?*

**YES** : Go to step 10AM8.

**NO** : Repair harness and connector.

**NOTE:**

In this case, repair the following:

- Open circuit in harness between ECM and rear wiring harness connector (R15)
- Poor contact in coupling connector (B98)

**10AM8 : CHECK HARNESS BETWEEN ECM AND COUPLING CONNECTOR IN REAR WIRING HARNESS.**

Measure resistance of harness between rear wiring harness connector and chassis ground.

**Connector & terminal**

**(B136) No. 16 — (R15) No. 11:**

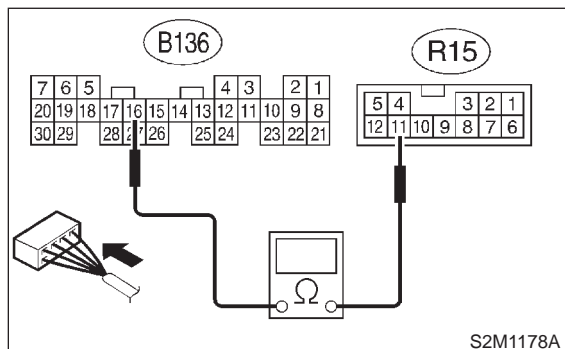

- CHECK** : *Is the resistance less than 1 Ω?*
- YES** : Go to step **10AM9**.
- NO** : Repair ground short circuit in harness between ECM and rear wiring harness connector (R15).

**10AM9 : CHECK FUEL TANK CORD.**

- 1) Disconnect connector from fuel tank pressure sensor.
- 2) Measure resistance of fuel tank cord.

**Connector & terminal**

**(R57) No. 11 — (R47) No. 2:**

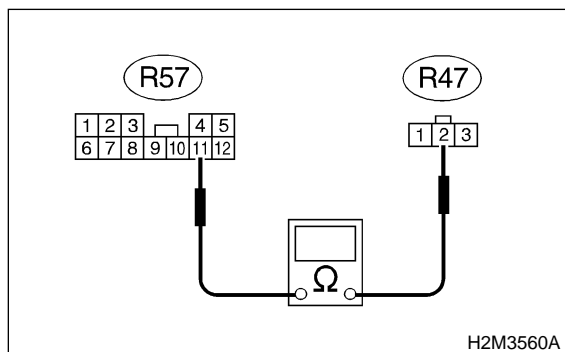

- CHECK** : *Is the resistance less than 1 Ω?*
- YES** : Go to step **10AM10**.
- NO** : Repair open circuit in fuel tank cord.

**10AM10 : CHECK FUEL TANK CORD.**

Measure resistance of fuel tank cord.

**Connector & terminal**

**(R57) No. 10 — (R47) No. 1:**

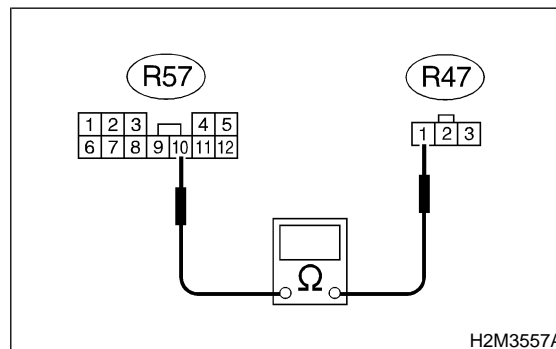

- CHECK** : *Is the resistance less than 1 Ω?*
- YES** : Go to step **10AM11**.
- NO** : Repair open circuit in fuel tank cord.

**10AM11 : CHECK POOR CONTACT.**

Check poor contact in fuel tank pressure sensor connector. <Ref. to FOREWORD [T3C1].>

- CHECK** : *Is there poor contact in fuel tank pressure sensor connector?*
- YES** : Repair poor contact in fuel tank pressure sensor connector.
- NO** : Replace fuel tank pressure sensor. <Ref. to 2-1 [W8A0].>

**10AM12 : CHECK HARNESS BETWEEN ECM AND FUEL TANK PRESSURE SENSOR CONNECTOR.**

- 1) Turn ignition switch to OFF.
- 2) Disconnect connector from fuel tank pressure sensor.
- 3) Turn ignition switch to ON.
- 4) Read data of fuel tank pressure sensor signal using Subaru Select Monitor or the OBD-II general scan tool.

## NOTE:

- Subaru Select Monitor

For detailed operation procedure, refer to the "READ CURRENT DATA SHOWN ON DISPLAY FOR ENGINE". <Ref. to 2-7 [T3C4].>

- OBD-II general scan tool

For detailed operation procedures, refer to the OBD-II General Scan Tool Instruction Manual.

**CHECK** : ***Is the value more than 2.8 kPa (21.0 mmHg, 0.827 inHg)?***

**YES** : Repair battery short circuit in harness between ECM and fuel tank pressure sensor connector.

**NO** : Replace fuel tank pressure sensor. <Ref. to 2-1 [W8A0].>

**AN: DTC P0461 — FUEL LEVEL SENSOR CIRCUIT RANGE/PERFORMANCE PROBLEM —**

- **DTC DETECTING CONDITION:**
  - Two consecutive driving cycles with fault

**CAUTION:**

After repair or replacement of faulty parts, conduct CLEAR MEMORY MODE <Ref. to 2-7 [T3D0].> and INSPECTION MODE <Ref. to 2-7 [T3E0].>

● **WIRING DIAGRAM:**

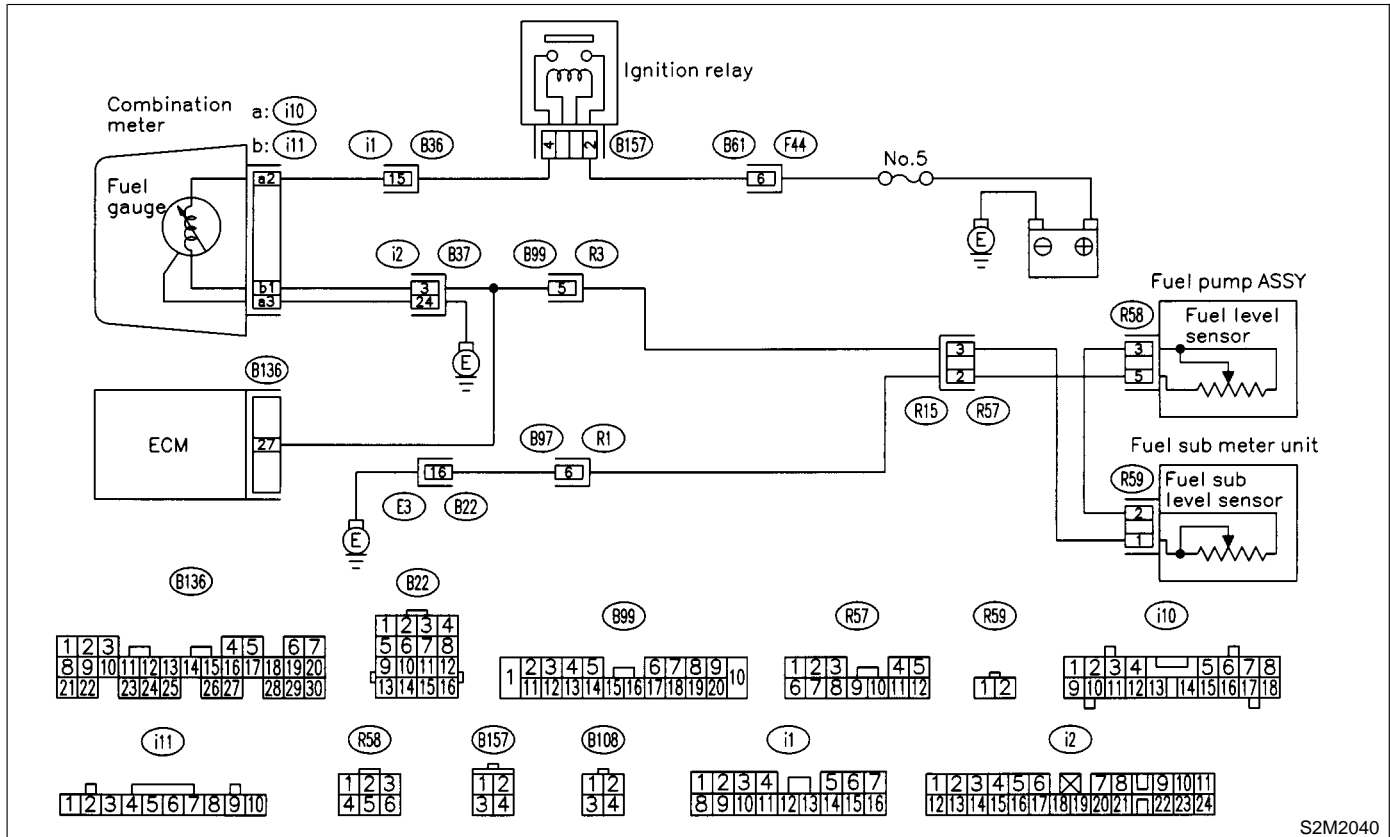

S2M2040

**10AN1 : CHECK ANY OTHER DTC ON DISPLAY.**

- CHECK :** Does the Subaru Select Monitor or OBD-II general scan tool indicate DTC P0462 or P0463?
- YES :** Inspect DTC P0462 or P0463 using "10. Diagnostics Chart with Trouble Code". <Ref. to 2-7 [T10A0].>

**NOTE:**

In this case, it is not necessary to inspect this trouble.

- NO :** Replace fuel sending unit <Ref. to 2-1 [W5A0].> and fuel sub level sensor <Ref. to 2-1 [W7A0].>



**AO: DTC P0462 — FUEL LEVEL SENSOR CIRCUIT LOW INPUT —**

**DTC DETECTING CONDITION:**

- Two consecutive driving cycles with fault

**CAUTION:**

After repair or replacement of faulty parts, conduct CLEAR MEMORY MODE <Ref. to 2-7 [T3D0].> and INSPECTION MODE <Ref. to 2-7 [T3E0].>

**WIRING DIAGRAM:**

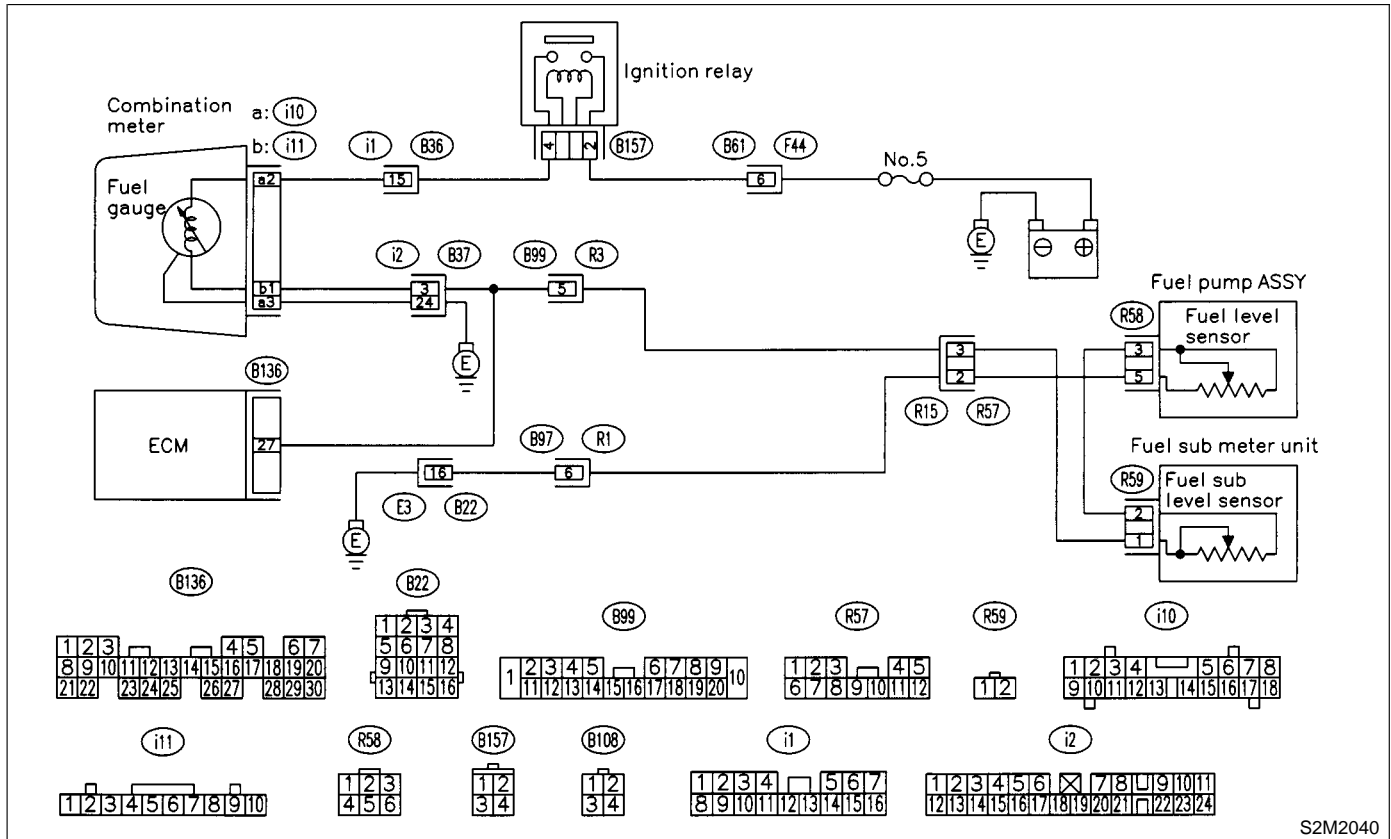

S2M2040

**10A01 : CHECK SPEEDOMETER AND TACHOMETER OPERATION IN COMBINATION METER.**

- CHECK** : Does speedometer and tachometer operate normally?
- YES** : Go to step 10A02.
- NO** : Repair or replace combination meter.

**10AO2 : CHECK INPUT SIGNAL FOR ECM.**

- 1) Turn ignition switch to ON. (Engine OFF)
- 2) Measure voltage between ECM connector and chassis ground.

**Connector & terminal**

**(B136) No. 27 (+) — Chassis ground (-):**

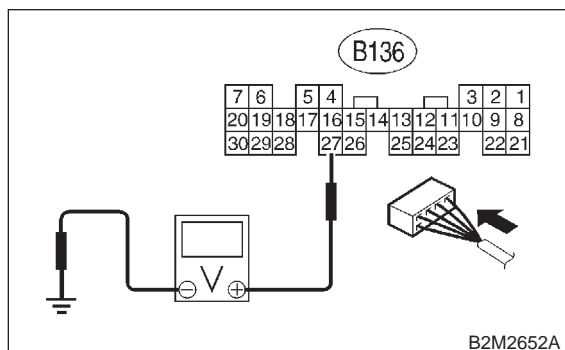

- CHECK** : *Is the voltage less than 0.12 V?*
- YES** : Go to step 10AO6.
- NO** : Go to step 10AO3.

**10AO3 : CHECK INPUT SIGNAL FOR ECM. (USING SUBARU SELECT MONITOR.)**

Read data of fuel level sensor signal using Subaru Select Monitor.

**NOTE:**

- Subaru Select Monitor
- For detailed operation procedure, refer to the "READ CURRENT DATA SHOWN ON DISPLAY FOR ENGINE". <Ref. to 2-7 [T3C4].>

- CHECK** : *Does the value change less than 0.12 V by shaking harness and connector of ECM while monitoring the value with Subaru Select Monitor?*
- YES** : Repair poor contact in ECM connector.
- NO** : Even if MIL lights up, the circuit has returned to a normal condition at this time. A temporary poor contact of the connector may be the cause.

**NOTE:**

- In this case, repair the following:
- Poor contact in combination meter connector
  - Poor contact in ECM connector
  - Poor contact in coupling connectors (B99 and R57)

**10AO4 : CHECK INPUT VOLTAGE OF ECM.**

- 1) Turn ignition switch to OFF.
- 2) Separate fuel tank cord connector (R57) and rear wiring harness connector (R15).
- 3) Turn ignition switch to ON.
- 4) Measure voltage of harness between ECM connector and chassis ground.

**Connector & terminal**

**(B136) No. 27 (+) — Chassis ground (-):**

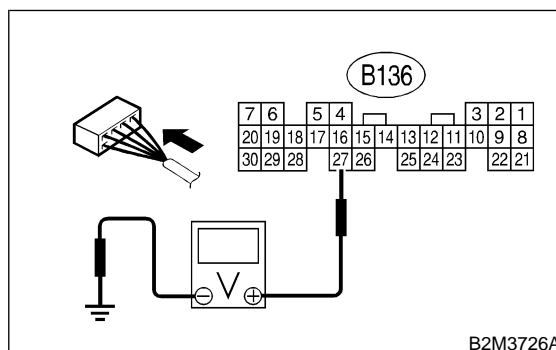

- CHECK** : *Is the voltage more than 0.12 V?*
- YES** : Go to step 10AO4.
- NO** : Go to step 10AO7.

**10AO5 : CHECK HARNESS BETWEEN ECM AND COMBINATION METER.**

- 1) Turn ignition switch to OFF.
- 2) Disconnect connector from connector (i10) and ECM connector.
- 3) Measure resistance between ECM and chassis ground.

**Connector & terminal**

**(B136) No. 27 — Chassis ground:**

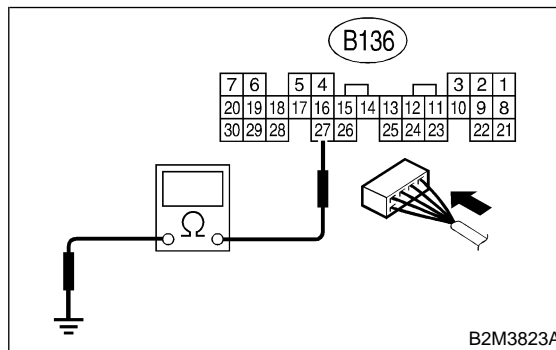

- CHECK** : *Is the resistance more than 1 MΩ?*
- YES** : Go to step 10AO6.
- NO** : Repair ground short circuit in harness between ECM and combination meter connector.

**10A06 : CHECK HARNESS BETWEEN ECM AND COMBINATION METER.**

Measure resistance between ECM and combination meter connector.

**Connector & terminal**

**(B136) No. 27 — (i11) No. 1:**

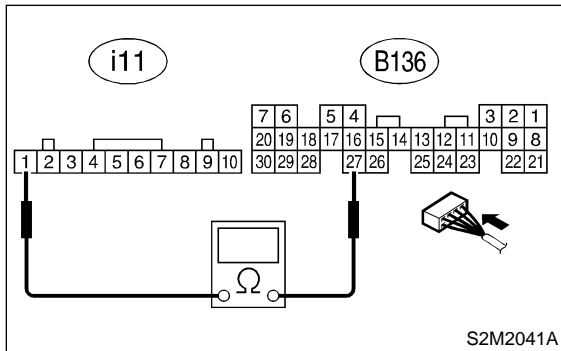

- CHECK** : **Is the resistance less than 10 Ω?**
- YES** : Repair or replace combination meter. <Ref. to 6-2 [W8A0].>
- NO** : Repair open circuit between ECM and combination meter connector.

**NOTE:**

In this case, repair the following:  
Poor contact in coupling connector (R98)

**10A07 : CHECK FUEL TANK CORD.**

- 1) Turn ignition switch to OFF.
- 2) Disconnect connector from fuel sub level sensor.
- 3) Measure resistance between fuel sub level sensor and chassis ground.

**Connector & terminal**

**(R59) No. 1 — Chassis ground:**

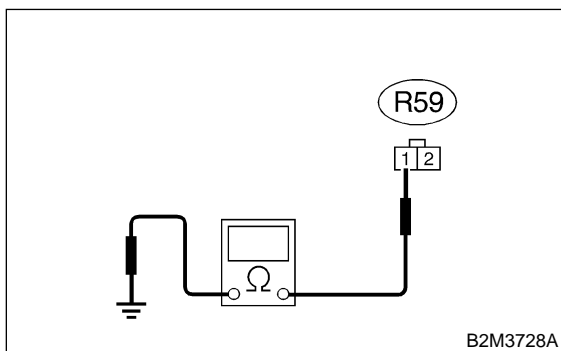

- CHECK** : **Is the resistance more than 1 MΩ?**
- YES** : Go to step 10A08.
- NO** : Repair ground short circuit in fuel tank cord.

**10A08 : CHECK FUEL TANK CORD.**

- 1) Disconnect connector from fuel pump assembly.
- 2) Measure resistance between fuel pump assembly and chassis ground.

**Connector & terminal**

**(R59) No. 2 — Chassis ground:**

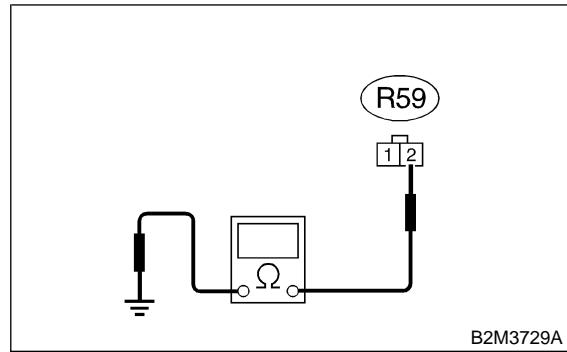

- CHECK** : **Is the resistance more than 1 MΩ?**
- YES** : Go to step 10A09.
- NO** : Repair ground short circuit in fuel tank cord.

**10A09 : CHECK FUEL LEVEL SENSOR.**

**WARNING:**

During work procedures, if fuel tank is more than 3/4 full, be careful because fuel may spill.

- 1) Remove fuel pump assembly. <Ref. to 2-8 [W3A0].>
- 2) Measure resistance between fuel level sensor and terminals with its float set to the full position.

**Terminals**

**No. 3 — No. 6:**

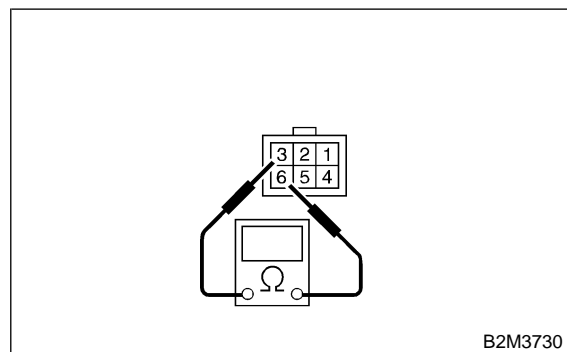

- CHECK** : **Is the resistance between 0.5 and 2.5 Ω?**
- YES** : Go to step 10A010.
- NO** : Replace fuel level sensor.

**10A010 : CHECK FUEL SUB LEVEL SENSOR.****WARNING:**

During work procedures, if fuel tank is more than 3/4 full, be careful because fuel may spill.

- 1) Remove fuel sub level sensor. <Ref. to 2-8 [W6A0].>
- 2) Measure resistance between fuel sub level sensor and terminals with its float set to the full position.

**Terminals**

**No. 1 — No. 2:**

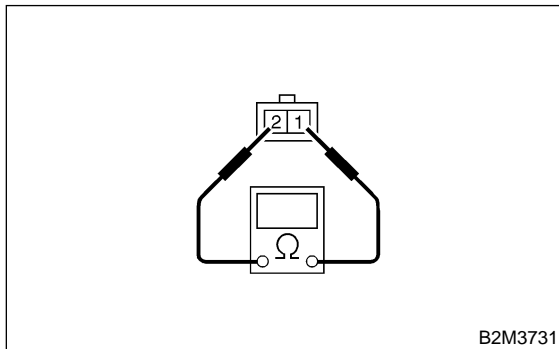

- CHECK** : **Is the resistance between 0.5 and 2.5 Ω?**
- YES** : Repair poor contact in harness between ECM and combination meter connector.
- NO** : Replace fuel sub level sensor.

**AP: DTC P0463 — FUEL LEVEL SENSOR CIRCUIT HIGH INPUT —**

**DTC DETECTING CONDITION:**

- Two consecutive driving cycles with fault

**CAUTION:**

After repair or replacement of faulty parts, conduct CLEAR MEMORY MODE <Ref. to 2-7 [T3D0].> and INSPECTION MODE <Ref. to 2-7 [T3E0].>

**WIRING DIAGRAM:**

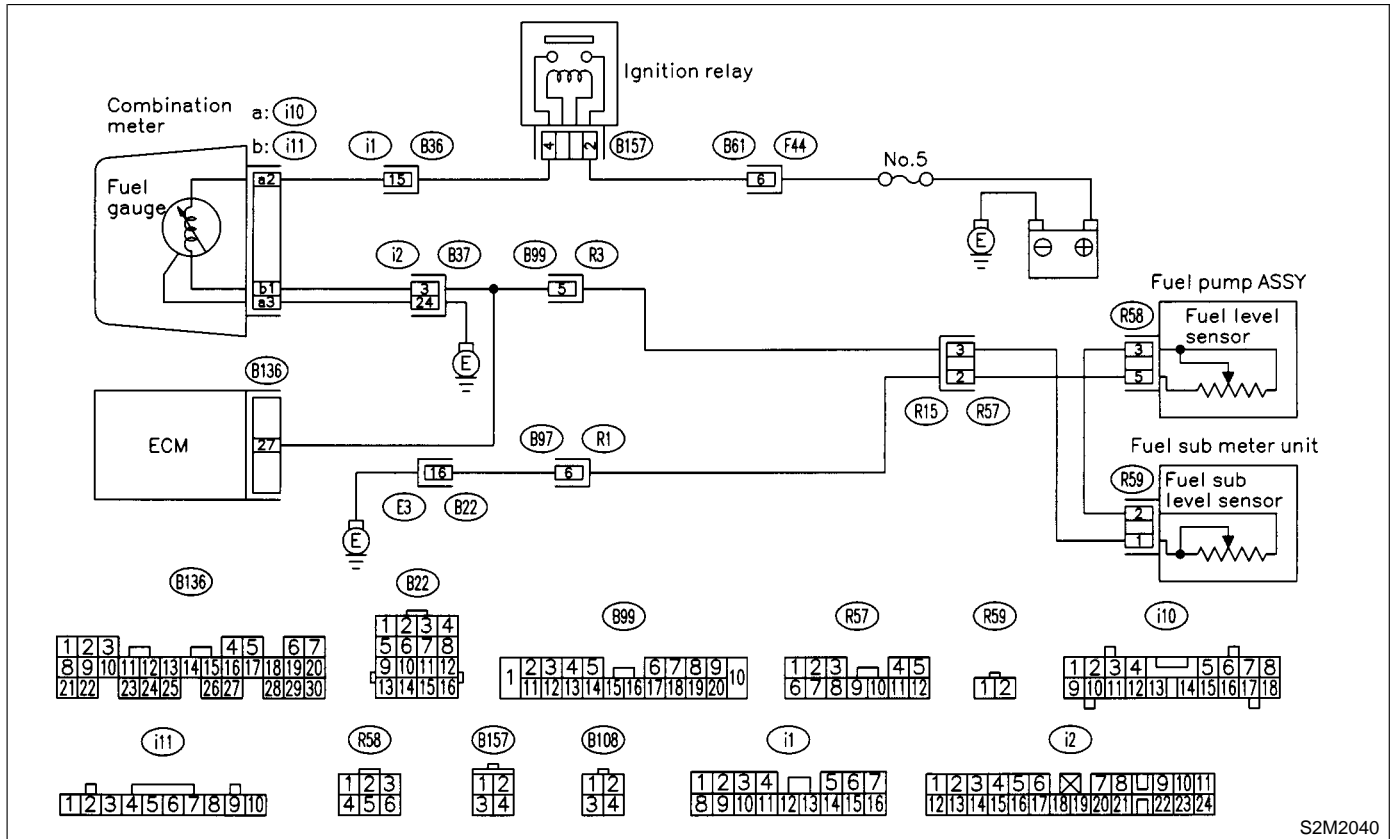

S2M2040

**10AP1 : CHECK SPEEDOMETER AND TACHOMETER OPERATION IN COMBINATION METER.**

- CHECK** : Does speedometer and tachometer operate normally?
- YES** : Go to step 10AP2.
- NO** : Repair or replace combination meter. <Ref. to 6-2 [W8A0].>

**10AP2 : CHECK INPUT SIGNAL FOR ECM.**

- 1) Turn ignition switch to ON. (Engine OFF)
- 2) Measure voltage between ECM connector and chassis ground.

**Connector & terminal**

**(B136) No. 27 (+) — Chassis ground (-):**

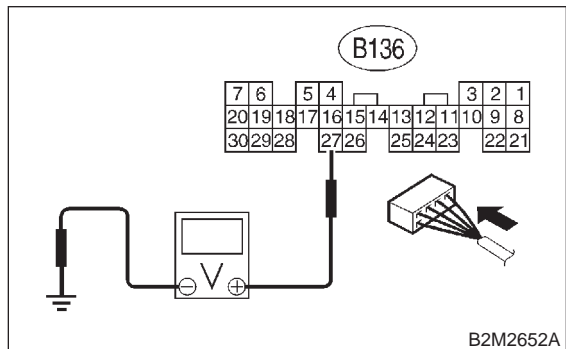

- CHECK** : **Is the voltage more than 4.75 V?**
- YES** : Go to step **10AP3**.
- NO** : Even if MIL lights up, the circuit has returned to a normal condition at this time. A temporary poor contact of the connector may be the cause.

**NOTE:**

In this case, repair the following:

- Poor contact in fuel pump connector
- Poor contact in coupling connector (B22, R97, B99 and R57)

**10AP3 : CHECK INPUT VOLTAGE OF ECM.**

- 1) Turn ignition switch to OFF.
- 2) Disconnect combination meter connector (i10) and ECM connector.
- 3) Turn ignition switch to ON.
- 4) Measure voltage of harness between ECM and chassis ground.

**Connector & terminal**

**(B136) No. 27 (+) — Chassis ground (-):**

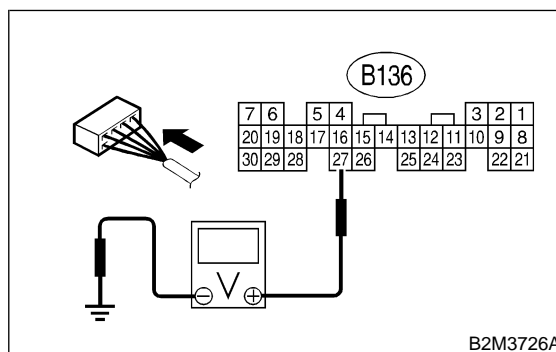

- CHECK** : **Is the voltage more than 4.75 V?**
- YES** : Go to step **10AP4**.
- NO** : Repair battery short circuit between ECM and combination meter connector.

**10AP4 : CHECK HARNESS BETWEEN ECM AND FUEL TANK CORD.**

- 1) Turn ignition switch to OFF.
- 2) Separate fuel tank cord connector (R57) and rear wiring harness connector (R15).
- 3) Measure resistance between ECM and fuel tank cord.

**Connector & terminal**

**(B136) No. 27 — (R15) No. 3:**

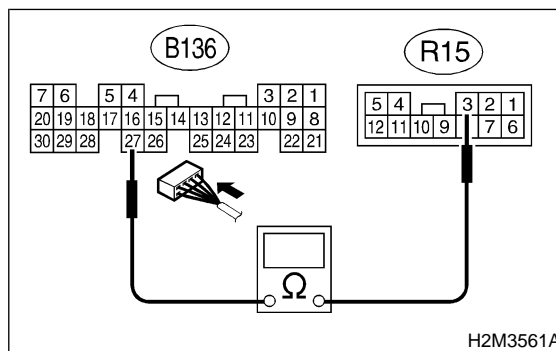

- CHECK** : **Is the resistance less than 5 Ω?**
- YES** : Go to step **10AP5**.
- NO** : Repair open circuit between ECM and fuel tank cord.

**10AP5 : CHECK HARNESS BETWEEN FUEL TANK CORD AND CHASSIS GROUND.**

Measure resistance between fuel tank cord and chassis ground.

**Connector & terminal**  
**(R15) No. 2 — Chassis ground:**

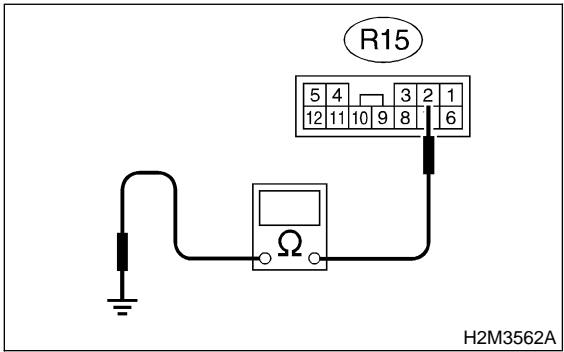

- CHECK** : **Is the resistance less than 5 Ω?**
- YES** : Go to step **10AP6**.
- NO** : Repair open circuit between fuel tank cord and chassis ground.

**NOTE:**

In this case, repair the following:  
Poor contact in coupling connectors (B22 and B99)

**10AP6 : CHECK FUEL TANK CORD.**

- 1) Disconnect connector from fuel level sensor.
- 2) Measure resistance between fuel level sensor and coupling connector.

**Connector & terminal**  
**(R57) No. 2 — (R58) No. 5:**

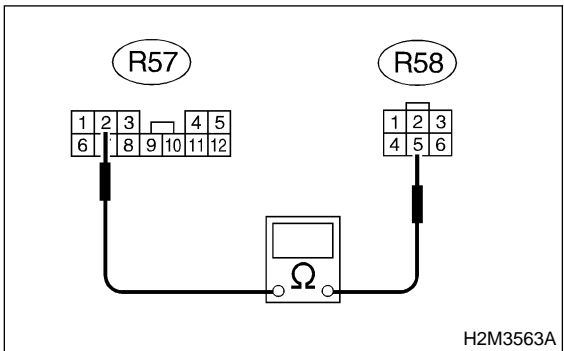

- CHECK** : **Is the resistance less than 10 Ω?**
- YES** : Go to step **10AP7**.
- NO** : Repair open circuit between coupling connector and fuel level sensor.

**10AP7 : CHECK FUEL TANK CORD.**

- 1) Disconnect connector from fuel sub level sensor.
- 2) Measure resistance between fuel level sensor and fuel sub level sensor.

**Connector & terminal**  
**(R58) No. 3 — (R59) No. 2:**

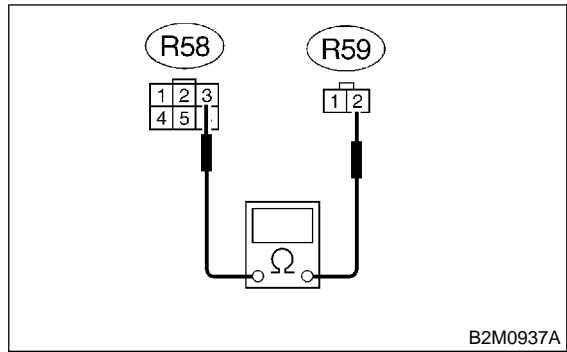

- CHECK** : **Is the resistance less than 10 Ω?**
- YES** : Go to step **10AP8**.
- NO** : Repair open circuit between fuel level sensor and fuel sub level sensor.

**10AP8 : CHECK FUEL TANK CORD.**

Measure resistance between fuel sub level sensor and coupling connector.

**Connector & terminal**  
**(R57) No. 3 — (R59) No. 1:**

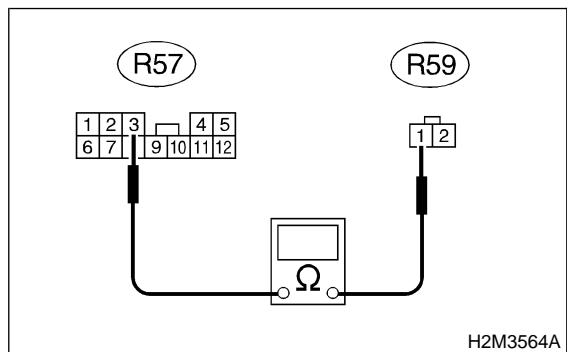

- CHECK** : **Is the resistance less than 10 Ω?**
- YES** : Go to step **10AP9**.
- NO** : Repair open circuit between coupling connector and fuel sub level sensor.

**10AP9 : CHECK FUEL LEVEL SENSOR.**

**WARNING:**

During work procedures, if fuel tank is more than 3/4 full, be careful because fuel may spill.

- 1) Remove fuel pump assembly. <Ref. to 2-8 [W3A0].>
- 2) While moving fuel level sensor float up and down, measure resistance between fuel level sensor terminals.

**Terminals**

**No. 3 — No. 6:**

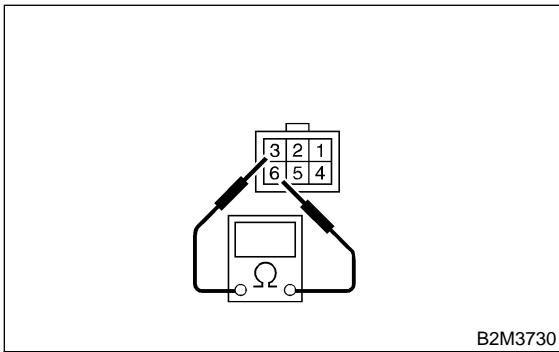

- CHECK** : **Is the resistance more than 54.5 Ω?**
- YES** : Replace fuel level sensor. <Ref. to 2-8 [W3A0].>
- NO** : Go to step **10AP10**.

**10AP10 : CHECK FUEL SUB LEVEL SENSOR.**

**WARNING:**

During work procedures, if fuel tank is more than 3/4 full, be careful because fuel may spill.

- 1) Remove fuel sub level sensor. <Ref. to 2-8 [W6A0].>
- 2) While moving fuel sub level sensor float up and down, measure resistance between fuel sub level sensor terminals.

**Terminals**

**No. 1 — No. 2:**

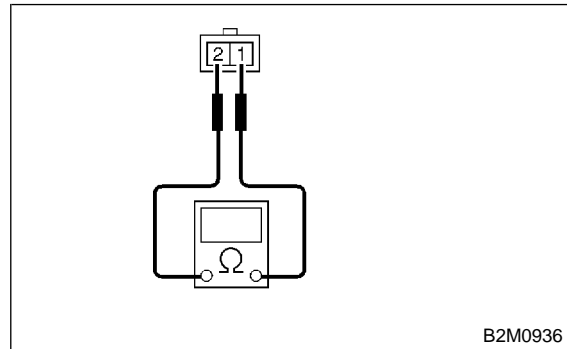

- CHECK** : **Is the resistance more than 41.5 Ω?**
- YES** : Replace fuel sub level sensor. <Ref. to 2-8 [W6A0].>
- NO** : Replace combination meter. <Ref. to 6-2 [W13A1].>



**AQ: DTC P0480 — COOLING FAN RELAY 1 CIRCUIT LOW INPUT —**

- **DTC DETECTING CONDITION:**
  - Two consecutive driving cycles with fault
- **TROUBLE SYMPTOM:**
  - Radiator fan does not operate properly.
  - Overheating

**CAUTION:**

After repair or replacement of faulty parts, conduct CLEAR MEMORY MODE <Ref. to 2-7 [T3D0].> and INSPECTION MODE <Ref. to 2-7 [T3E0].>

● **WIRING DIAGRAM:**

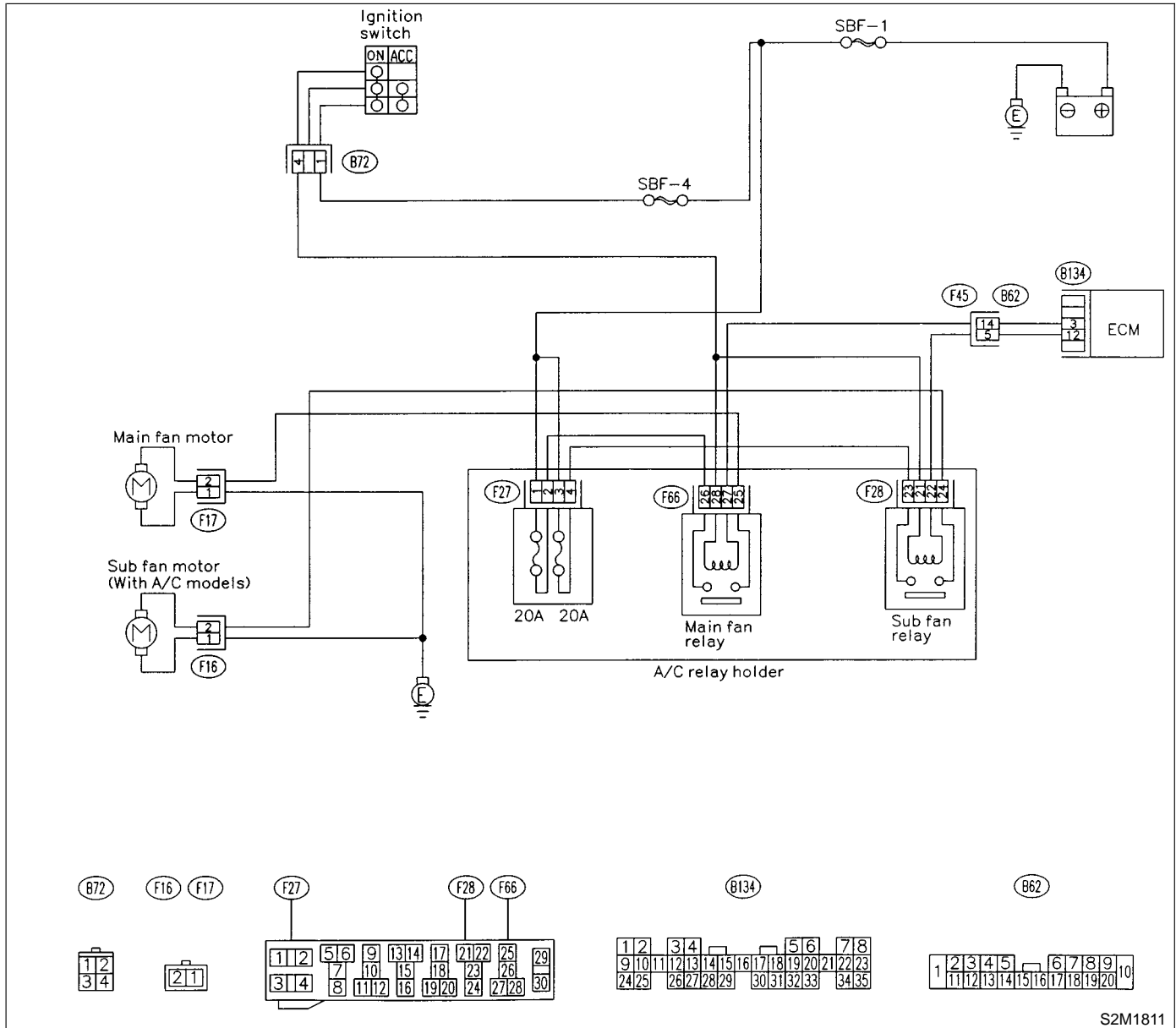

S2M1811

**10AQ1 : CHECK OUTPUT SIGNAL FROM ECM.**

- 1) Turn ignition switch to OFF.
- 2) Connect test mode connector at the lower portion of instrument panel (on the driver's side), to the side of the center console box.

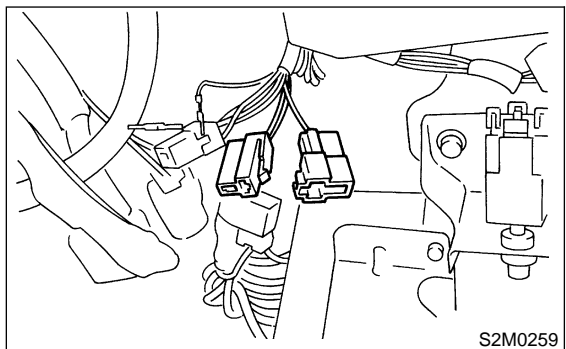

- 3) Turn ignition switch to ON.
- 4) While operating radiator fan relay, measure voltage between ECM terminal and ground.

**NOTE:**

Radiator fan relay operation can be executed using Subaru Select Monitor. For procedure, refer to "COMPULSORY VALVE OPERATION CHECK MODE". <Ref. to 2-7 [T3F0].>

**Connector & terminal**

**(B134) No. 3 (+) — Chassis ground (-):**

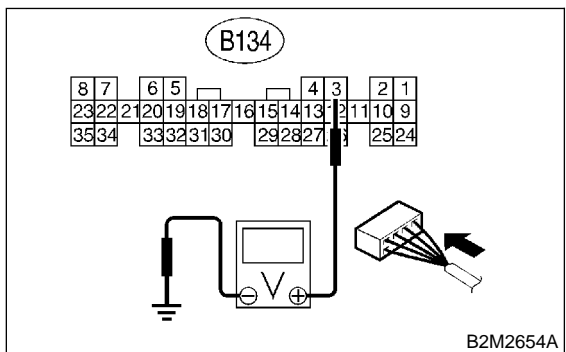

- CHECK** : Does voltage change between 0 and 10 V?
- YES** : Repair poor contact in ECM connector.
- NO** : Go to step **10AQ2**.

**10AQ2 : CHECK GROUND SHORT CIRCUIT IN RADIATOR FAN RELAY 1 CONTROL CIRCUIT.**

- 1) Turn ignition switch to OFF.
- 2) Disconnect connectors from ECM.
- 3) Measure resistance of harness between ECM connector and chassis ground.

**Connector & terminal**

**(B134) No. 3 — Chassis ground:**

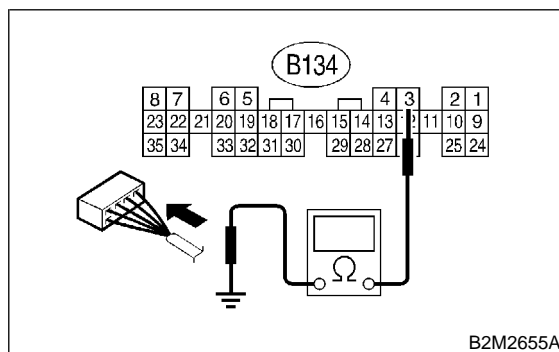

- CHECK** : Is the resistance less than 10 Ω?
- YES** : Repair ground short circuit in radiator fan relay 1 control circuit.
- NO** : Go to step **10AQ3**.

**10AQ3 : CHECK POWER SUPPLY FOR RELAY.**

- 1) Remove main fan relay from A/C relay holder.
- 2) Turn ignition switch to ON.
- 3) Measure voltage between fuse and relay box (F/B) connector and chassis ground.

**Connector & terminal**

**(F66) No. 28 (+) — Chassis ground (-):**

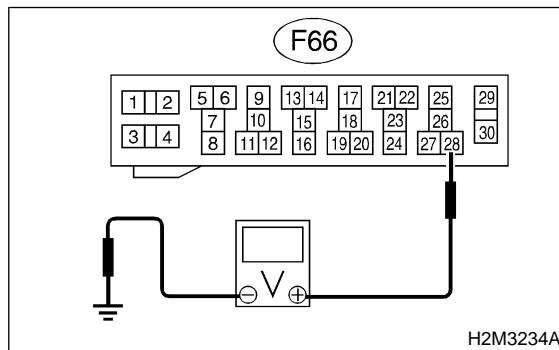

- CHECK** : Is the voltage more than 10 V?
- YES** : Go to step **10AQ4**.
- NO** : Repair open circuit in harness between ignition switch and fuse and relay box (F/B) connector.

**10AQ4 : CHECK MAIN FAN RELAY.**

- 1) Turn ignition switch to OFF.
- 2) Measure resistance between main fan relay terminals.

**Terminal**

**No. 5 — No. 6:**

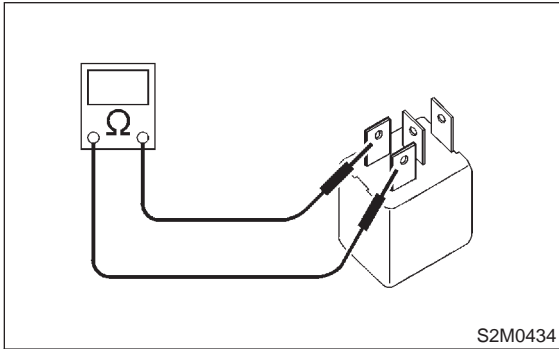

- CHECK** : *Is the resistance between 87 and 107  $\Omega$ ?*
- YES** : Go to step **10AQ5**.
- NO** : Replace main fan relay.

**10AQ5 : CHECK OPEN CIRCUIT IN MAIN FAN RELAY CONTROL CIRCUIT.**

Measure resistance of harness between ECM and main fan relay connector.

**Connector & terminal**

**(B134) No. 3 — (F66) No. 27:**

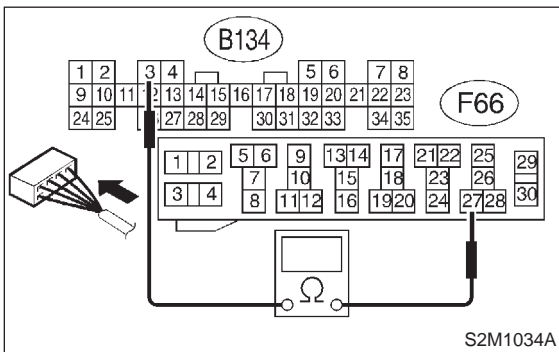

- CHECK** : *Is the resistance less than 1  $\Omega$ ?*
- YES** : Go to step **10AQ6**.
- NO** : Repair harness and connector.

**NOTE:**

In this case, repair the following:

- Open circuit in harness between ECM and main fan relay connector
- Poor contact in coupling connector (F45)

**10AQ6 : CHECK POOR CONTACT.**

Check poor contact in ECM or main fan relay connector. <Ref. to FOREWORD [T3C1].>

- CHECK** : *Is there poor contact in ECM or main fan relay connector?*
- YES** : Repair poor contact in ECM or main fan relay connector.
- NO** : Contact with SOA service.

**MEMO:**

**AR: DTC P0483 — COOLING FAN FUNCTION PROBLEM —**

- **DTC DETECTING CONDITION:**
  - Two consecutive driving cycles with fault
- **TROUBLE SYMPTOM:**
  - Occurrence of noise
  - Overheating

**CAUTION:**

After repair or replacement of faulty parts, conduct CLEAR MEMORY MODE <Ref. to 2-7 [T3D0].> and INSPECTION MODE <Ref. to 2-7 [T3E0].>

**NOTE:**

If the vehicle, with the engine idling, is placed very close to a wall or another vehicle, preventing normal cooling function, the OBD system may detect malfunction.

● **WIRING DIAGRAM:**

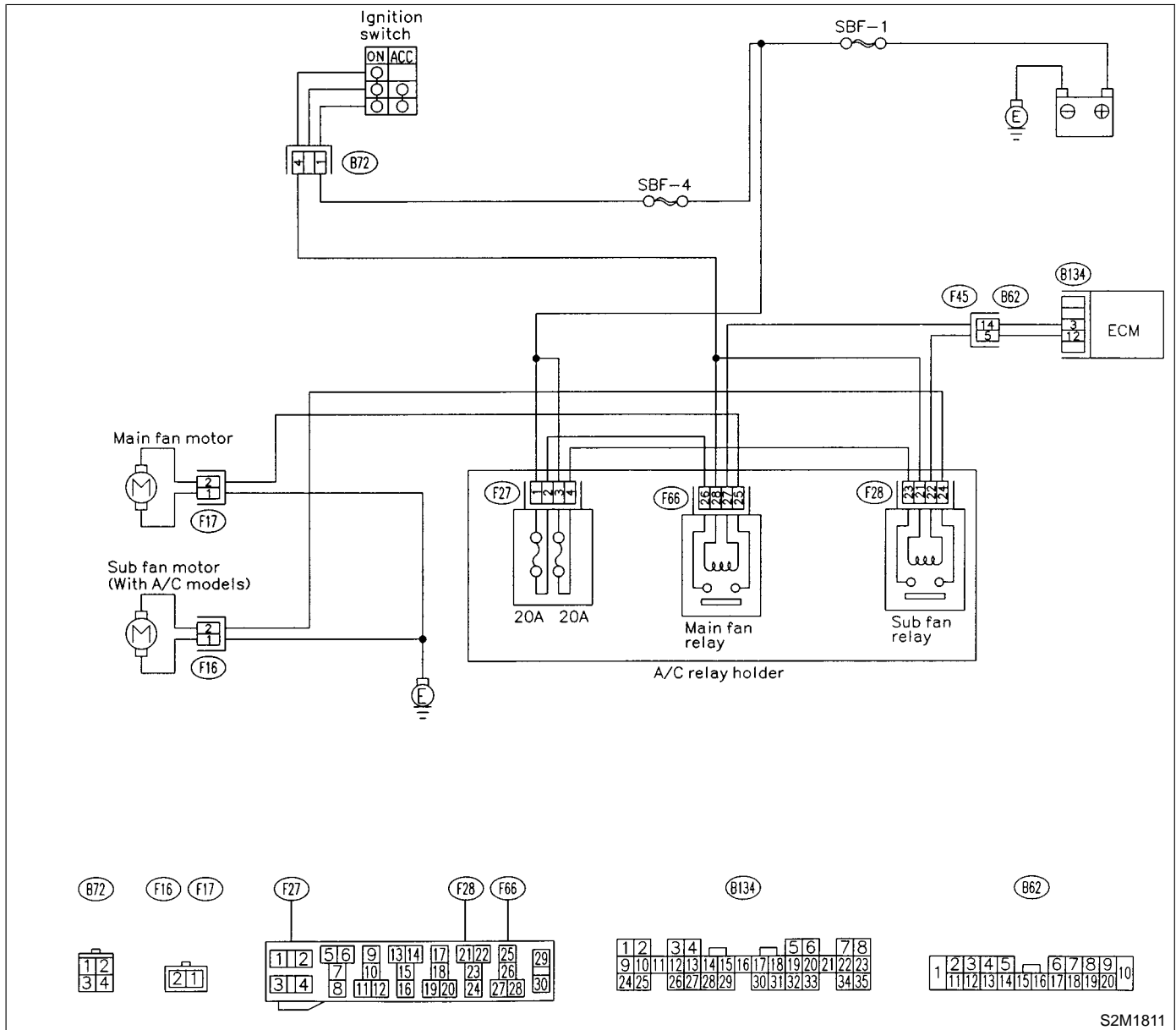

S2M1811

**10AR1 : CHECK ANY OTHER DTC ON DISPLAY.**

- CHECK** : *Is there any other DTC on display?*
- YES** : Inspect the relevant DTC using "10. Diagnostics Chart with Trouble Code".  
<Ref. to 2-7 [T10A0].>
- NO** : Check engine cooling system. <Ref. to 2-5 [T100].>

**AS: DTC P0500 — VEHICLE SPEED SENSOR MALFUNCTION —**

- **DTC DETECTING CONDITION:**
  - Immediately at fault recognition

**CAUTION:**

After repair or replacement of faulty parts, conduct **CLEAR MEMORY MODE** <Ref. to 2-7 [T3D0].> and **INSPECTION MODE** <Ref. to 2-7 [T3E0].>

● **WIRING DIAGRAM:**

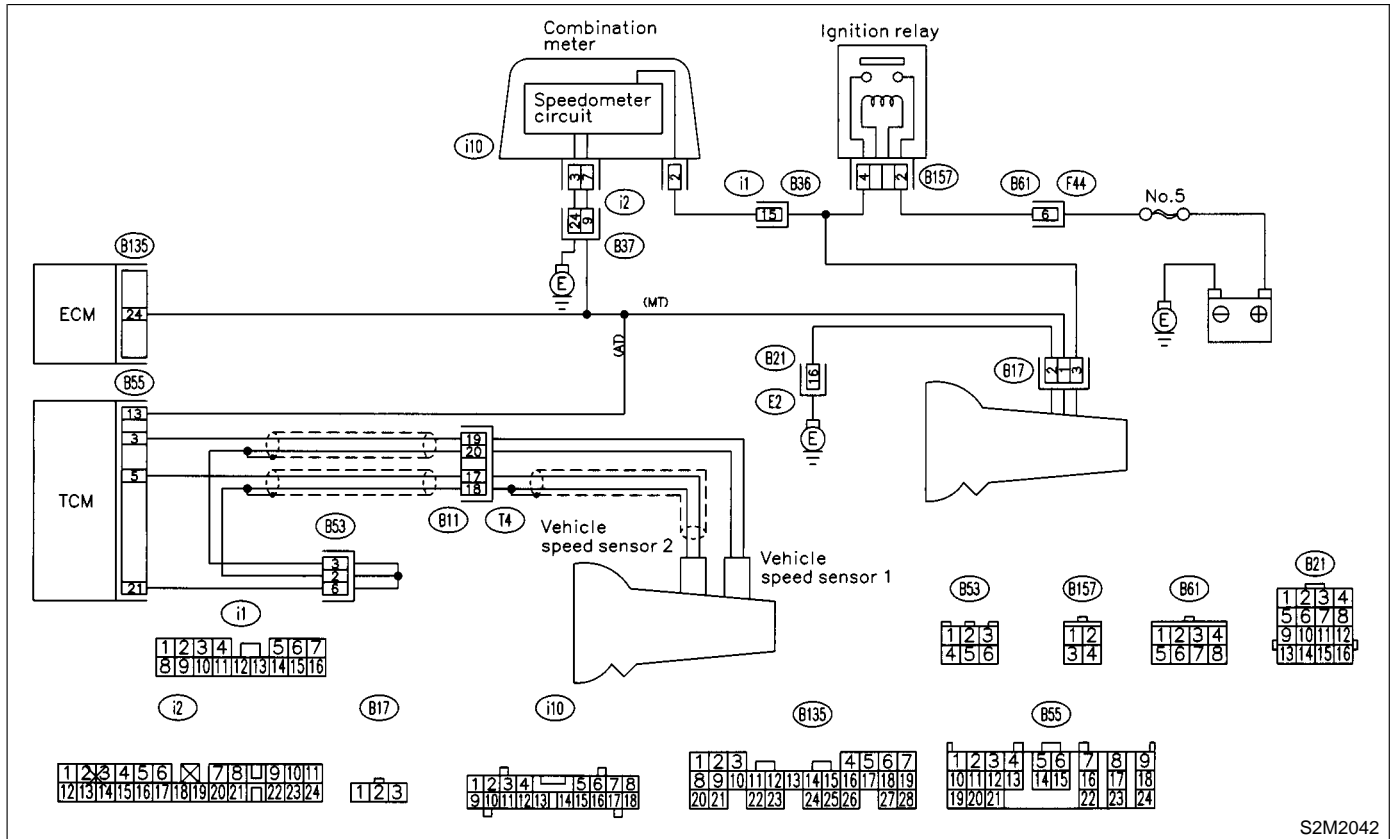

S2M2042

**10AS1 : CHECK TRANSMISSION TYPE.**

- CHECK : *Is transmission type AT?*
- YES : Go to step 10AS2.
- NO : Go to step 10AS3.

**10AS2 : CHECK DTC P0720 ON DISPLAY.**

- CHECK : *Does the Subaru Select Monitor or OBD-II general scan tool indicate DTC P0720?*
- YES : Check vehicle speed sensor 2 signal circuit. <Ref. to 3-2 [T8F0].>
- NO : Go to step 10AS3.

**10AS3 : CHECK SPEEDOMETER OPERATION IN COMBINATION METER.**

- CHECK : *Does speedometer operate normally?*
- YES : Go to step 10AS4.
- NO : Check speedometer and vehicle speed sensor. <Ref. to 6-2 [T1A0].>

**10AS4 : CHECK HARNESS BETWEEN ECM AND COMBINATION METER CONNECTOR.**

- 1) Turn ignition switch to OFF.
- 2) Disconnect connector from combination meter.
- 3) Measure resistance between ECM and combination meter.

**Connector & terminal**

**(B135) No. 24 — (i10) No. 7:**

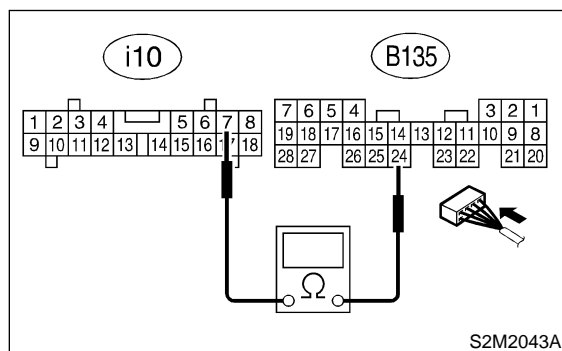

**CHECK** : **Is the resistance less than 10 Ω?**

**YES** : Repair poor contact in ECM connector.

**NO** : Repair harness and connector.

**NOTE:**

In this case, repair the following:

- Open circuit in harness between ECM and combination meter connector
- Poor contact in ECM connector
- Poor contact in combination meter connector



**AT: DTC P0506 — IDLE CONTROL SYSTEM RPM LOWER THAN EXPECTED**

- **DTC DETECTING CONDITION:**
  - Two consecutive driving cycles with fault
- **TROUBLE SYMPTOM:**
  - Engine is difficult to start.
  - Engine does not start.
  - Erroneous idling
  - Engine stalls.

**CAUTION:**

After repair or replacement of faulty parts, conduct CLEAR MEMORY MODE <Ref. to 2-7 [T3D0].> and INSPECTION MODE <Ref. to 2-7 [T3E0].>

● **WIRING DIAGRAM:**

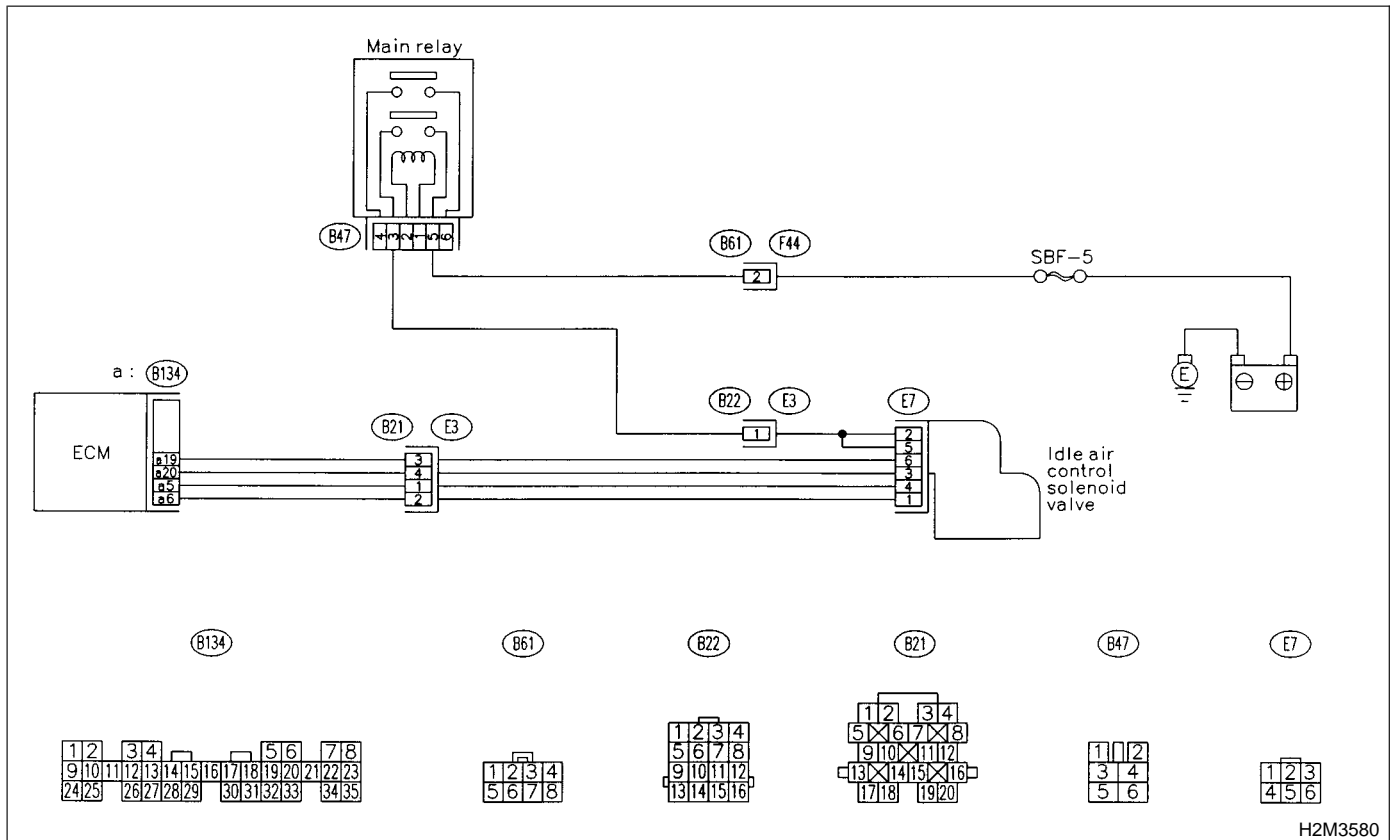

**10AT1 : CHECK ANY OTHER DTC ON DISPLAY.**

**CHECK** : *Does the Subaru Select Monitor or OBD-II general scan tool indicate DTC P1510, P1511, P1512, P1513, P1514, P1515, P1516 or P1517?*

**YES** : Inspect DTC P1510, P1511, P1512, P1513, P1514, P1515, P1516 or P1517 using "10. Diagnostics Chart with Trouble Code". <Ref. to 2-7 [T10A0].>

**NOTE:**

In this case, it is not necessary to inspect DTC P0506.

**NO** : Go to step **10AT2**.

**10AT2 : CHECK AIR BY-PASS LINE.**

- 1) Turn ignition switch to OFF.
- 2) Remove idle air control solenoid valve from throttle body. <Ref. to 2-7 [W13A0].>
- 3) Remove throttle body from intake manifold. <Ref. to 2-7 [W2A0].>
- 4) Using an air gun, force air into idle air control solenoid valve installation area. Confirm that forced air subsequently escapes from throttle body interior.

**CHECK** : *Does air flow out?*

**YES** : Replace idle air control solenoid valve. <Ref. to 2-7 [W13A0].>

**NO** : Replace throttle body. <Ref. to 2-7 [W2A0].>

**AU: DTC P0507 — IDLE CONTROL SYSTEM RPM HIGHER THAN EXPECTED**

**DTC DETECTING CONDITION:**

- Two consecutive driving cycles with fault

**TROUBLE SYMPTOM:**

- Engine keeps running at higher revolution than specified idling revolution.

**CAUTION:**

After repair or replacement of faulty parts, conduct CLEAR MEMORY MODE <Ref. to 2-7 [T3D0].> and INSPECTION MODE <Ref. to 2-7 [T3E0].>

**WIRING DIAGRAM:**

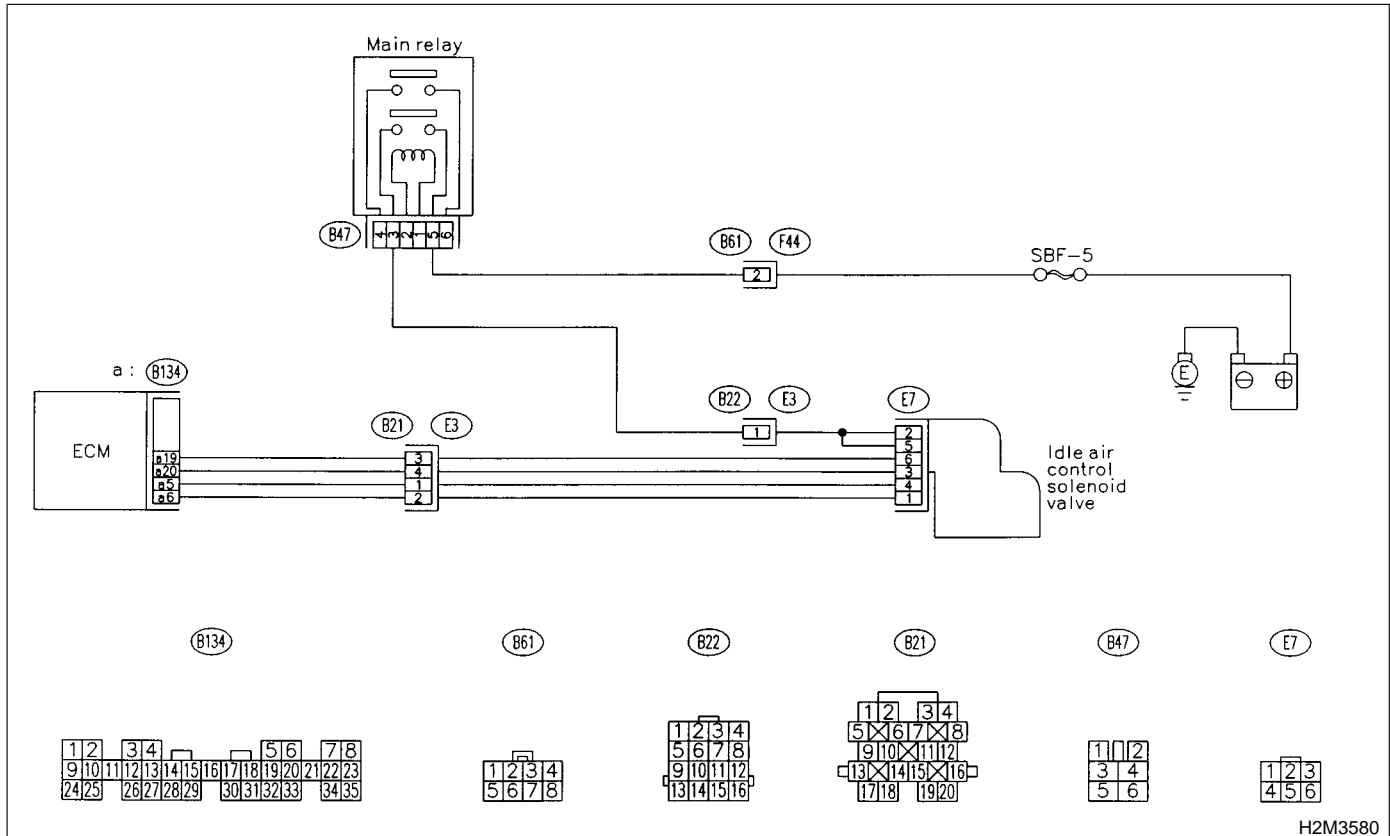

H2M3580

**10AU1 : CHECK ANY OTHER DTC ON DISPLAY.**

**CHECK** : Does the Subaru Select Monitor or OBD-II general scan tool indicate DTC P1510, P1511, P1512, P1513, P1514, P1515, P1516 or P1517?

**YES** : Inspect DTC P1510, P1511, P1512, P1513, P1514, P1515, P1516 or P1517 using "10. Diagnostics Chart with Trouble Code". <Ref. to 2-7 [T10A0].>

**NOTE:**  
In this case, it is not necessary to inspect DTC P0507.

**NO** : Go to step 10AU2.

**10AU2 : CHECK AIR INTAKE SYSTEM.**

- 1) Turn ignition switch to ON.
- 2) Start engine, and idle it.
- 3) Check the following items.
  - Loose installation of intake manifold, idle air control solenoid valve and throttle body
  - Cracks of intake manifold gasket, idle air control solenoid valve gasket and throttle body gasket
  - Disconnections of vacuum hoses

**CHECK** : Is there a fault in air intake system?

**YES** : Repair air suction and leaks.

**NO** : Go to step 10AU3.

**10AU3 : CHECK THROTTLE CABLE.**

- CHECK** : *Does throttle cable have play for adjustment?*
- YES** : Go to step **10AU4**.
- NO** : Adjust throttle cable. <Ref. to 4-5 [W1A3].>

**10AU4 : CHECK AIR BY-PASS LINE.**

- 1) Turn ignition switch to OFF.
- 2) Remove idle air control solenoid valve from throttle body. <Ref. to 2-7 [W13A0].>
- 3) Confirm that there are no foreign particles in by-pass air line.

- CHECK** : *Are foreign particles in by-pass air line?*
- YES** : Remove foreign particles from by-pass air line.
- NO** : Replace idle air control solenoid valve. <Ref. to 2-7 [W13A0].>

**AV: DTC P0601 — INTERNAL CONTROL MODULE MEMORY CHECK SUM ERROR —**

- **DTC DETECTING CONDITION:**
  - Two consecutive driving cycles with fault
- **TROUBLE SYMPTOM:**
  - Engine does not start.
  - Engine stalls.

**CAUTION:**

After repair or replacement of faulty parts, conduct CLEAR MEMORY MODE <Ref. to 2-7 [T3D0].> and INSPECTION MODE <Ref. to 2-7 [T3E0].>

● **WIRING DIAGRAM:**

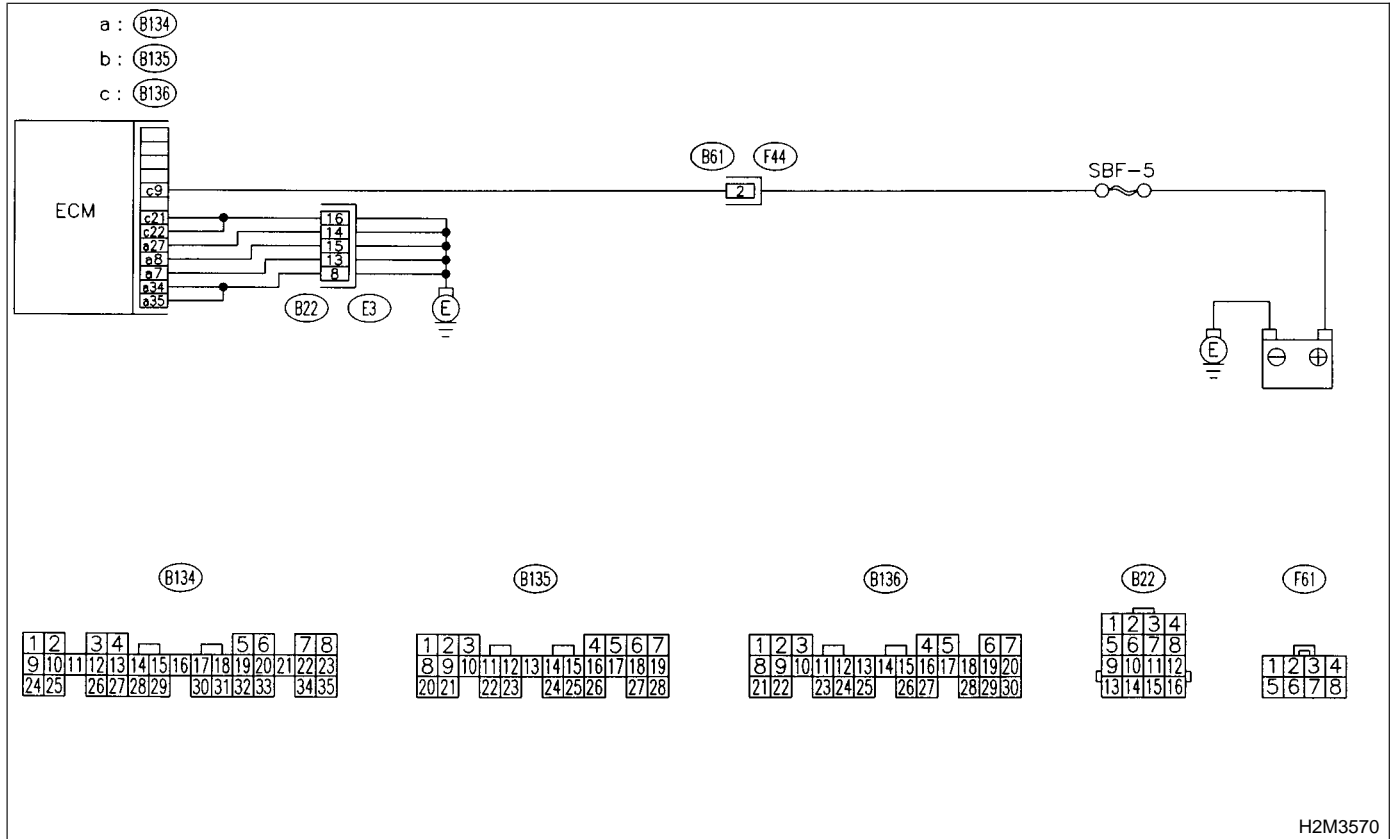

**10AV1 : CHECK ANY OTHER DTC ON DISPLAY.**

- CHECK** : Does the Subaru Select Monitor or OBD-II general scan tool indicate DTC P0601?
- YES** : Replace ECM. <Ref. to 2-7 [W17A0].>
- NO** : It is not necessary to inspect DTC P0601.

**MEMO:**

**AW: DTC P0703 — BRAKE SWITCH INPUT MALFUNCTION —**

**● DTC DETECTING CONDITION:**

- Two consecutive driving cycles with fault

**CAUTION:**

After repair or replacement of faulty parts, conduct CLEAR MEMORY MODE <Ref. to 2-7 [T3D0].> and INSPECTION MODE <Ref. to 2-7 [T3E0].>.

**● WIRING DIAGRAM:**

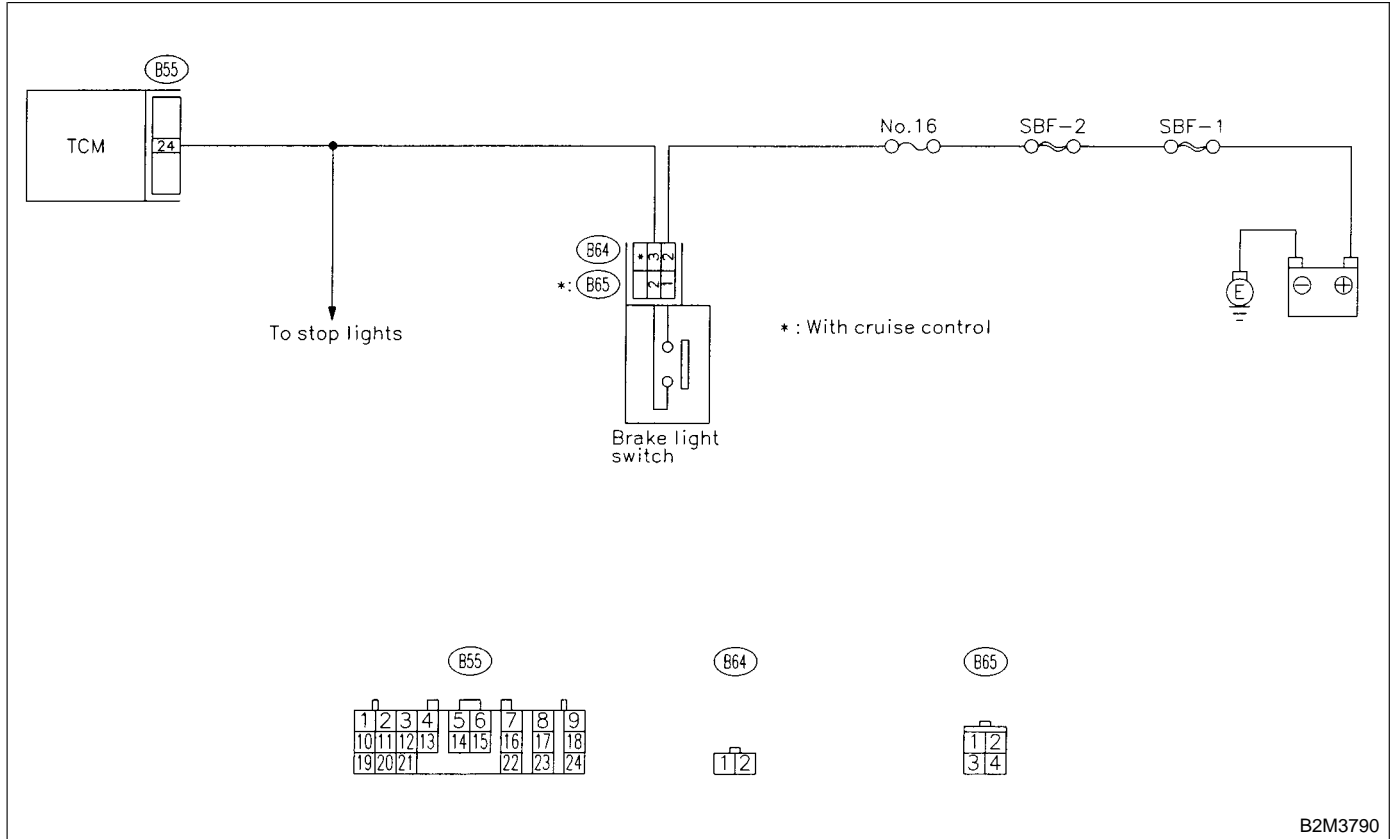

B2M3790

**10AW1 : CHECK OPERATION OF BRAKE LIGHT.**

- CHECK** : Does brake light come on when depressing the brake pedal?
- YES** : Go to step 10AW2.
- NO** : Repair or replace brake light circuit.

**10AW2 : CHECK HARNESS BETWEEN TCM AND BRAKE LIGHT SWITCH CONNECTOR.**

- 1) Disconnect connectors from TCM and brake light switch.
- 2) Measure resistance of harness between TCM and brake light switch connector.

**Connector & terminal**

**(B55) No. 24 — (B64) No. 2:**

**(B55) No. 24 — (B65) No. 3 (With cruise control):**

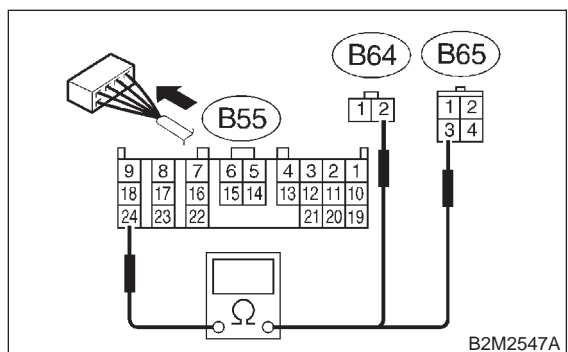

- CHECK** : *Is the resistance less than 1 Ω?*
- YES** : Go to step **10AW3**.
- NO** : Repair or replace harness and connector.

**NOTE:**

In this case, repair the following:

- Open circuit in harness between TCM and brake light switch connector
- Poor contact in TCM connector
- Poor contact in brake light switch connector

**10AW3 : CHECK HARNESS BETWEEN TCM AND BRAKE LIGHT SWITCH CONNECTOR.**

Measure resistance of harness between TCM and chassis ground.

**Connector & terminal**

**(B55) No. 24 — Chassis ground:**

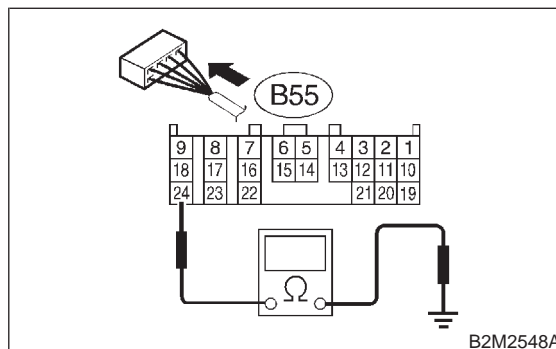

- CHECK** : *Is the resistance more than 1 MΩ?*
- YES** : Go to step **10AW4**.
- NO** : Repair ground short circuit in harness between TCM and brake light switch connector.

**10AW4 : CHECK INPUT SIGNAL FOR TCM.**

- 1) Connect connectors to TCM and brake light switch.
- 2) Measure voltage between TCM and chassis ground.

**Connector & terminal**

**(B55) No. 24 (+) — Chassis ground (-):**

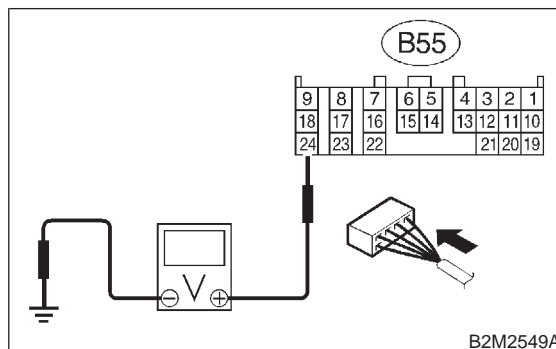

- CHECK** : *Is the voltage less than 1 V when releasing the brake pedal?*
- YES** : Go to step **10AW5**.
- NO** : Adjust or replace brake light switch. <Ref. to 4-5 [W1A1].>



**10AW5 : CHECK INPUT SIGNAL FOR TCM.**

Measure voltage between TCM and chassis ground.

**Connector & terminal**

**(B55) No. 24 (+) — Chassis ground (-):**

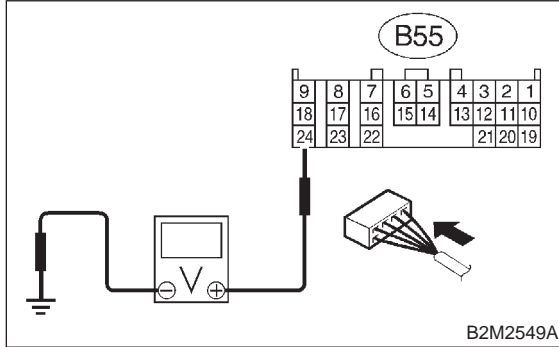

- CHECK** : *Is the voltage more than 10 V when depressing the brake pedal?*
- YES** : Go to step **10AW6**.
- NO** : Adjust or replace brake light switch. <Ref. to 4-5 [W1A1].>

**10AW6 : CHECK POOR CONTACT.**

Check poor contact in TCM connector. <Ref. to FOREWORD [T3C1].>

- CHECK** : *Is there poor contact in TCM connector?*
- YES** : Repair poor contact in TCM connector.
- NO** : Replace TCM. <Ref. to 3-2 [W23A0].>

**AX: DTC P0705 — TRANSMISSION RANGE SENSOR CIRCUIT MALFUNCTION —****● DTC DETECTING CONDITION:**

- Two consecutive driving cycles with fault

**● TROUBLE SYMPTOM:**

- Starter does not rotate when select lever is in “P” or “N” range.
- Starter rotates when select lever is in “R”, “D”, “3”, “2” or “1” range.
- Engine brake is not effected when select lever is in “3” range.
- Shift characteristics are erroneous.

**CAUTION:**

After repair or replacement of faulty parts, conduct CLEAR MEMORY MODE <Ref. to 2-7 [T3D0].> and INSPECTION MODE <Ref. to 2-7 [T3E0].>.

**NOTE:**

Check inhibitor switch circuit. <Ref. to 3-2 [T9T0].>

**AY: DTC P0710 — TRANSMISSION FLUID TEMPERATURE SENSOR CIRCUIT MALFUNCTION —****● DTC DETECTING CONDITION:**

- Two consecutive driving cycles with fault

**● TROUBLE SYMPTOM:**

- No shift up to 4th speed (after engine warm-up)
- No lock-up (after engine warm-up)
- Excessive shift shock

**CAUTION:**

After repair or replacement of faulty parts, conduct CLEAR MEMORY MODE <Ref. to 2-7 [T3D0].> and INSPECTION MODE <Ref. to 2-7 [T3E0].>.

**NOTE:**

Check ATF temperature sensor circuit. <Ref. to 3-2 [T8D0].>

**AZ: DTC P0715 — TORQUE CONVERTER TURBINE SPEED SENSOR CIRCUIT MALFUNCTION —****● DTC DETECTING CONDITION:**

- Two consecutive driving cycles with fault

**CAUTION:**

After repair or replacement of faulty parts, conduct CLEAR MEMORY MODE <Ref. to 2-7 [T3D0].> and INSPECTION MODE <Ref. to 2-7 [T3E0].>.

**NOTE:**

Check torque converter turbine speed sensor circuit. <Ref. to 3-2 [T8G0].>

**BA: DTC P0720 — OUTPUT SPEED SENSOR (VEHICLE SPEED SENSOR 2) CIRCUIT MALFUNCTION —****● DTC DETECTING CONDITION:**

- Two consecutive driving cycles with fault

**● TROUBLE SYMPTOM:**

- No shift or excessive tight corner “braking”

**CAUTION:**

After repair or replacement of faulty parts, conduct CLEAR MEMORY MODE <Ref. to 2-7 [T3D0].> and INSPECTION MODE <Ref. to 2-7 [T3E0].>.

**NOTE:**

Check vehicle speed sensor 2 circuit. <Ref. to 3-2 [T8F0].>

**BB: DTC P0725 — ENGINE SPEED INPUT CIRCUIT MALFUNCTION —****● DTC DETECTING CONDITION:**

- Two consecutive driving cycles with fault

**● TROUBLE SYMPTOM:**

- No lock-up (after engine warm-up)
- AT diagnostic indicator light (AT OIL TEMP indicator light) remains on when vehicle speed is “0”.

**CAUTION:**

**After repair or replacement of faulty parts, conduct CLEAR MEMORY MODE <Ref. to 2-7 [T3D0].> and INSPECTION MODE <Ref. to 2-7 [T3E0].>.**

**NOTE:**

Check engine speed input signal circuit. <Ref. to 3-2 [T8C0].>

**BC: DTC P0731 — GEAR 1 INCORRECT RATIO —****NOTE:**

For the diagnostic procedure, refer to DTC P0734. <Ref. to 2-7 [T10BF0].>

**BD: DTC P0732 — GEAR 2 INCORRECT RATIO —****NOTE:**

For the diagnostic procedure, refer to DTC P0734. <Ref. to 2-7 [T10BF0].>

**BE: DTC P0733 — GEAR 3 INCORRECT RATIO —****NOTE:**

For the diagnostic procedure, refer to DTC P0734. <Ref. to 2-7 [T10BF0].>

**BF: DTC P0734 — GEAR 4 INCORRECT RATIO —****● DTC DETECTING CONDITION:**

- Two consecutive driving cycles with fault

**● TROUBLE SYMPTOM:**

- Shift point too high or too low; engine brake not effected in “3” range; excessive shift shock; excessive tight corner “braking”

**CAUTION:**

After repair or replacement of faulty parts, conduct CLEAR MEMORY MODE <Ref. to 2-7 [T3D0].> and INSPECTION MODE <Ref. to 2-7 [T3E0].>.

**10BF1 : CHECK ANY OTHER DTC ON DISPLAY.**

**CHECK** : *Is there any other DTC on display?*

**YES** : Inspect relevant DTC using “10. Diagnostics Chart with Trouble Code”. <Ref. to 2-7 [T10A0].>

**NO** : Go to step **10BF2**.

**10BF2 : CHECK THROTTLE POSITION SENSOR CIRCUIT.**

Check throttle position sensor circuit. <Ref. to 3-2 [T8E0].>

**CHECK** : *Is there any trouble in throttle position sensor circuit?*

**YES** : Repair or replace throttle position sensor circuit.

**NO** : Go to step **10BF3**.

**10BF3 : CHECK VEHICLE SPEED SENSOR 2 CIRCUIT.**

Check vehicle speed sensor 2 circuit. <Ref. to 3-2 [T8F0].>

**CHECK** : *Is there any trouble in vehicle speed sensor 2 circuit?*

**YES** : Repair or replace vehicle speed sensor 2 circuit.

**NO** : Go to step **10BF4**.

**10BF4 : CHECK TORQUE CONVERTER TURBINE SPEED SENSOR CIRCUIT.**

Check torque converter turbine speed sensor circuit. <Ref. to 3-2 [T8G0].>

**CHECK** : *Is there any trouble in torque converter turbine speed sensor circuit?*

**YES** : Repair or replace torque converter turbine speed sensor circuit.

**NO** : Go to step **10BF5**.

**10BF5 : CHECK POOR CONTACT.**

Check poor contact in TCM connector. <Ref. to FOREWORD [T3C1].>

**CHECK** : *Is there poor contact in TCM connector?*

**YES** : Repair poor contact in TCM connector.

**NO** : Go to step **10BF6**.

**10BF6 : CHECK MECHANICAL TROUBLE.**

Check mechanical trouble in automatic transmission.

**CHECK** : *Is there any mechanical trouble in automatic transmission?*

**YES** : Repair or replace automatic transmission. <Ref. to 3-2 [W100].>

**NO** : Replace TCM. <Ref. to 3-2 [W23A0].>

**BG: DTC P0740 — TORQUE CONVERTER CLUTCH SYSTEM MALFUNCTION****• DTC DETECTING CONDITION:**

- Two consecutive driving cycles with fault

**• TROUBLE SYMPTOM:**

- No lock-up (after engine warm-up)
- No shift or excessive tight corner “braking”

**CAUTION:**

After repair or replacement of faulty parts, conduct CLEAR MEMORY MODE <Ref. to 2-7 [T3D0].> and INSPECTION MODE <Ref. to 2-7 [T3E0].>.

**10BG1 : CHECK ANY OTHER DTC ON DISPLAY.**

**CHECK** : *Is there any other DTC on display?*

**YES** : Inspect the relevant DTC using “10. Diagnostics Chart with Trouble Code”. <Ref. to 2-7 [T10A0].>

**NO** : Go to step **10BG2**.

**10BG2 : CHECK DUTY SOLENOID B CIRCUIT.**

Check duty solenoid B circuit. <Ref. to 3-2 [T8P0].>

**CHECK** : *Is there any trouble in duty solenoid B circuit?*

**YES** : Repair or replace duty solenoid B circuit.

**NO** : Go to step **10BG3**.

**10BG3 : CHECK THROTTLE POSITION SENSOR CIRCUIT.**

Check throttle position sensor circuit. <Ref. to 3-2 [T8E0].>

**CHECK** : *Is there any trouble in throttle position sensor circuit?*

**YES** : Repair or replace throttle position sensor circuit.

**NO** : Go to step **10BG4**.

**10BG4 : CHECK TORQUE CONVERTER TURBINE SPEED SENSOR CIRCUIT.**

Check torque converter turbine speed sensor circuit. <Ref. to 3-2 [T8G0].>

**CHECK** : *Is there any trouble in torque converter turbine speed sensor circuit?*

**YES** : Repair or replace torque converter turbine speed sensor circuit.

**NO** : Go to step **10BG5**.

**10BG5 : CHECK ENGINE SPEED INPUT CIRCUIT.**

Check engine speed input circuit. <Ref. to 3-2 [T8C0].>

**CHECK** : *Is there any trouble in engine speed input circuit?*

**YES** : Repair or replace engine speed input circuit.

**NO** : Go to step **10BG6**.

**10BG6 : CHECK INHIBITOR SWITCH CIRCUIT.**

Check inhibitor switch circuit. <Ref. to 3-2 [T9T0].>

**CHECK** : *Is there any trouble in inhibitor switch circuit?*

**YES** : Repair or replace inhibitor switch circuit.

**NO** : Go to step **10BG7**.

**10BG7 : CHECK BRAKE LIGHT SWITCH CIRCUIT.**

Check brake light switch circuit. <Ref. to 2-7 [T10AW0].>

**CHECK** : *Is there any trouble in brake light switch circuit?*

**YES** : Repair or replace brake light switch circuit.

**NO** : Go to step **10BG8**.

**10BG8 : CHECK ATF TEMPERATURE SENSOR CIRCUIT.**

Check ATF temperature sensor circuit. <Ref. to 3-2 [T8D0].>

**CHECK** : *Is there any trouble in ATF temperature sensor circuit?*

**YES** : Repair or replace ATF temperature sensor circuit.

**NO** : Go to step **10BG9**.

**10BG9 : CHECK POOR CONTACT.**

Check poor contact in TCM connector. <Ref. to FOREWORD [T3C1].>

**CHECK** : *Is there poor contact in TCM connector?*

**YES** : Repair poor contact in TCM connector.

**NO** : Go to step **10BG10**.

**10BG10 : CHECK MECHANICAL TROUBLE.**

Check mechanical trouble in automatic transmission.

**CHECK** : *Is there any mechanical trouble in automatic transmission?*

**YES** : Repair or replace automatic transmission. <Ref. to 3-2 [W100].>

**NO** : Replace TCM. <Ref. to 3-2 [W23A0].>

**BH: DTC P0743 — TORQUE CONVERTER CLUTCH SYSTEM (LOCK-UP DUTY SOLENOID) ELECTRICAL —**

- **DTC DETECTING CONDITION:**
  - Two consecutive driving cycles with fault
- **TROUBLE SYMPTOM:**
  - No lock-up (after engine warm-up)

**CAUTION:**

After repair or replacement of faulty parts, conduct CLEAR MEMORY MODE <Ref. to 2-7 [T3D0].> and INSPECTION MODE <Ref. to 2-7 [T3E0].>.

**NOTE:**

Check lock-up duty solenoid circuit. <Ref. to 3-2 [T8R0].>

**BI: DTC P0748 — PRESSURE CONTROL SOLENOID (LINE PRESSURE DUTY SOLENOID) ELECTRICAL —**

- **DTC DETECTING CONDITION:**
  - Two consecutive driving cycles with fault
- **TROUBLE SYMPTOM:**
  - Excessive shift shock

**CAUTION:**

After repair or replacement of faulty parts, conduct CLEAR MEMORY MODE <Ref. to 2-7 [T3D0].> and INSPECTION MODE <Ref. to 2-7 [T3E0].>.

**NOTE:**

Check line pressure duty solenoid circuit. <Ref. to 3-2 [T8N0].>

**BJ: DTC P0753 — SHIFT SOLENOID A (SHIFT SOLENOID 1) ELECTRICAL —**

- **DTC DETECTING CONDITION:**
  - Two consecutive driving cycles with fault
- **TROUBLE SYMPTOM:**
  - No shift

**CAUTION:**

After repair or replacement of faulty parts, conduct CLEAR MEMORY MODE <Ref. to 2-7 [T3D0].> and INSPECTION MODE <Ref. to 2-7 [T3E0].>.

**NOTE:**

Check shift solenoid 1 circuit. <Ref. to 3-2 [T8J0].>

**BK: DTC P0758 — SHIFT SOLENOID B (SHIFT SOLENOID 2) ELECTRICAL —**

- **DTC DETECTING CONDITION:**
  - Two consecutive driving cycles with fault
- **TROUBLE SYMPTOM:**
  - No shift

**CAUTION:**

After repair or replacement of faulty parts, conduct CLEAR MEMORY MODE <Ref. to 2-7 [T3D0].> and INSPECTION MODE <Ref. to 2-7 [T3E0].>.

**NOTE:**

Check shift solenoid 2 circuit. <Ref. to 3-2 [T8K0].>

**BL: DTC P1100 — STARTER SWITCH CIRCUIT LOW INPUT —**

- **DTC DETECTING CONDITION:**
  - Two consecutive driving cycles with fault
- **TROUBLE SYMPTOM:**
  - Failure of engine to start

**CAUTION:**

After repair or replacement of faulty parts, conduct CLEAR MEMORY MODE <Ref. to 2-7 [T3D0].> and INSPECTION MODE <Ref. to 2-7 [T3E0].>

● **WIRING DIAGRAM:**

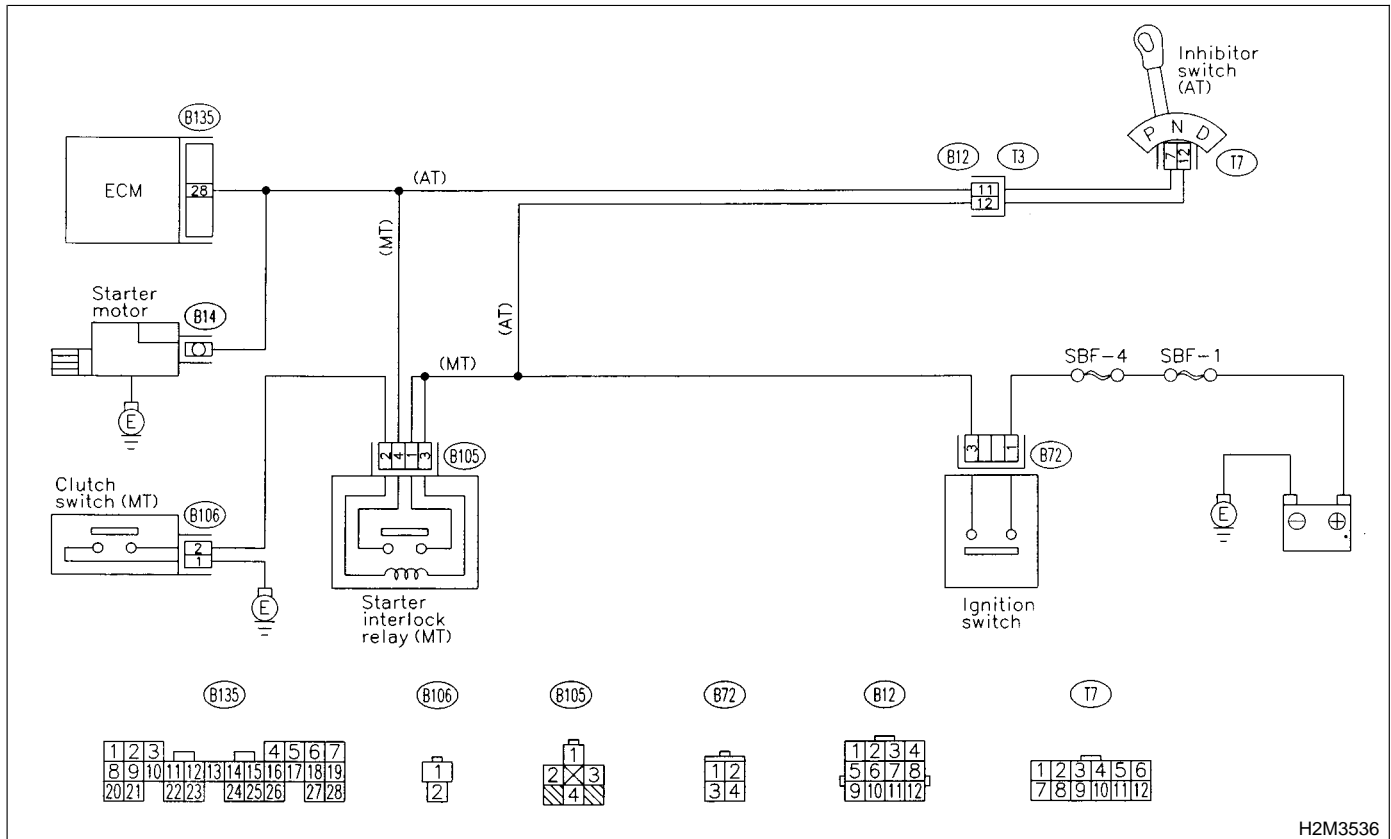

H2M3536

**10BL1 : CHECK OPERATION OF STARTER MOTOR.**

**NOTE:**

- On AT vehicles, place the inhibitor switch in the "P" or "N" position.
- On MT vehicles, depress the clutch pedal.

**CHECK** : *Does starter motor operate when ignition switch to "ST"?*

**YES** : Repair harness and connector.

**NOTE:**

In this case, repair the following:

- Open or ground short circuit in harness between ECM and starter motor connector.
- Poor contact in ECM connector.

**NO** : Check starter motor circuit. <Ref. to 2-7 [T8B0].>



**BM: DTC P1101 — NEUTRAL POSITION SWITCH CIRCUIT LOW INPUT [MT VEHICLES] OR NEUTRAL POSITION SWITCH CIRCUIT HIGH INPUT [AT VEHICLES] —**

- **DTC DETECTING CONDITION:**
  - Two consecutive driving cycles with fault
- **TROUBLE SYMPTOM:**
  - Erroneous idling

**CAUTION:**

After repair or replacement of faulty parts, conduct CLEAR MEMORY MODE <Ref. to 2-7 [T3D0].> and INSPECTION MODE <Ref. to 2-7 [T3E0].>

● **WIRING DIAGRAM:**

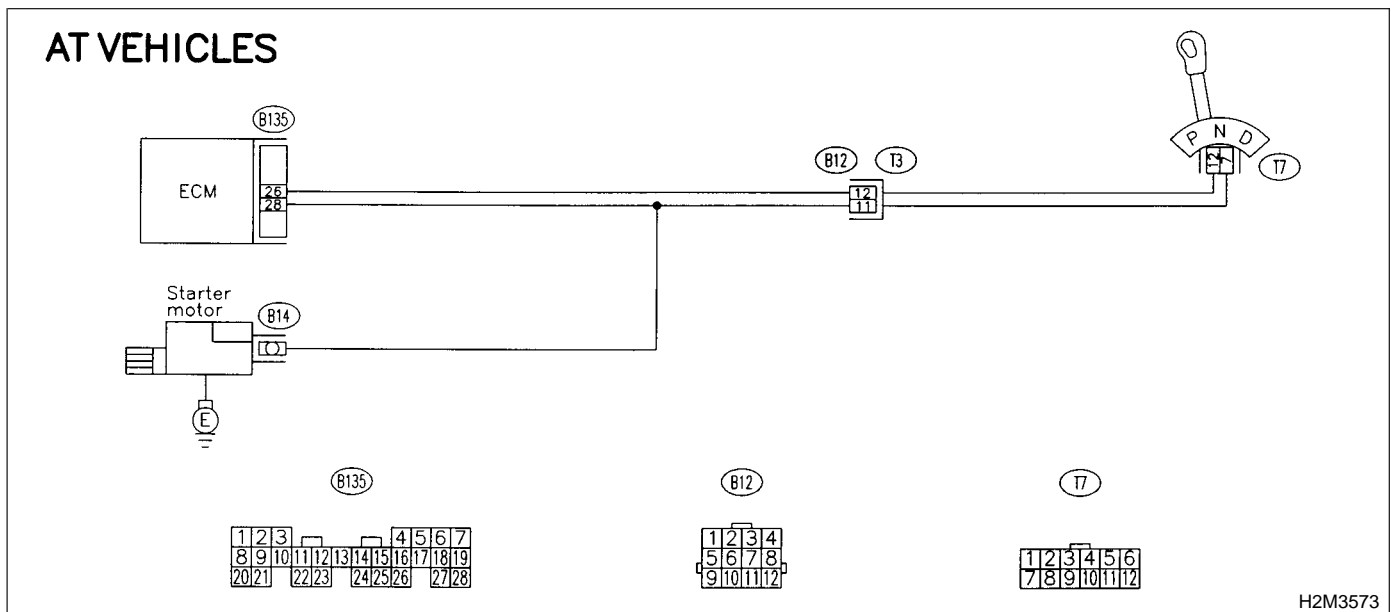
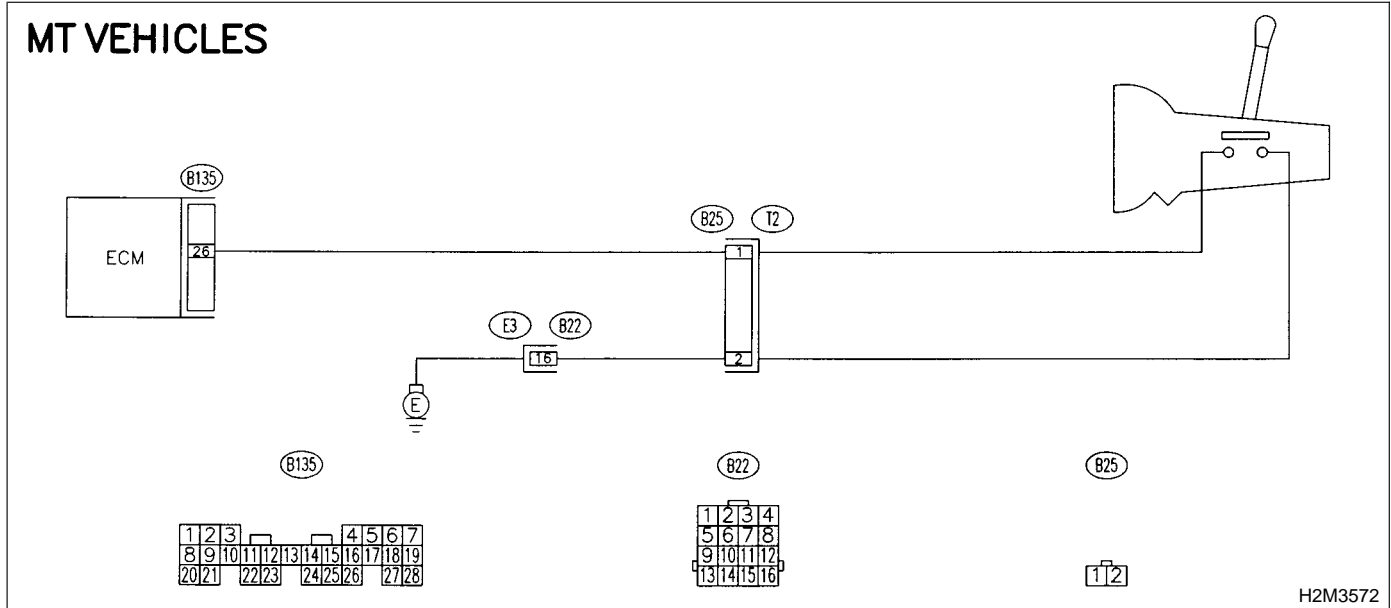

**10BM1 : CHECK TRANSMISSION TYPE.**

- CHECK** : *Is transmission type MT?*
- YES** : Go to step **10BM2**.
- NO** : Go to step **10BM8**.

**10BM2 : CHECK INPUT SIGNAL FOR ECM.**

- 1) Turn ignition switch to ON.
- 2) Measure voltage between ECM and chassis ground.

**Connector & terminal**  
**(B135) No. 26 (+) — Chassis ground (-):**

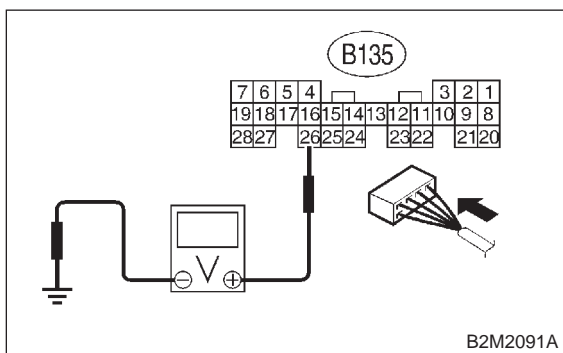

- CHECK** : *Is the voltage more than 10 V in neutral position?*
- YES** : Go to step **10BM3**.
- NO** : Go to step **10BM5**.

**10BM3 : CHECK INPUT SIGNAL FOR ECM.**

Measure voltage between ECM and chassis ground.

**Connector & terminal**  
**(B135) No. 26 (+) — Chassis ground (-):**

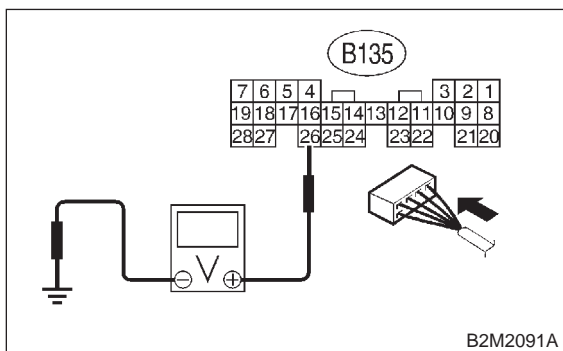

- CHECK** : *Is the voltage less than 1 V in other positions?*
- YES** : Go to step **10BM4**.
- NO** : Go to step **10BM5**.

**10BM4 : CHECK POOR CONTACT.**

Check poor contact in ECM connector. <Ref. to FOREWORD [T3C1].>

- CHECK** : *Is there poor contact in ECM connector?*
- YES** : Repair poor contact in ECM connector.
- NO** : Contact with SOA service.

**NOTE:**

Inspection by DTM is required, because probable cause is deterioration of multiple parts.

**10BM5 : CHECK NEUTRAL POSITION SWITCH.**

- 1) Turn ignition switch to OFF.
- 2) Disconnect connector from transmission harness.
- 3) Measure resistance between transmission harness and connector terminals.

**Connector & terminal**  
**(T2) No. 1 — No. 2:**

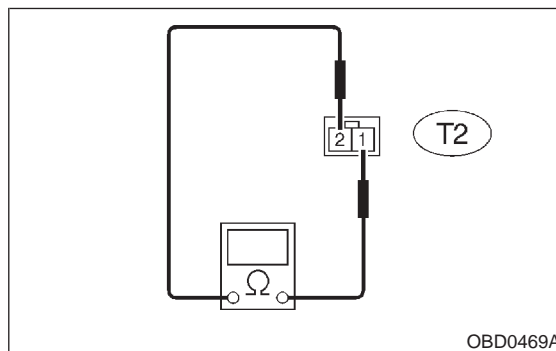

- CHECK** : *Is the resistance more than 1 MΩ in neutral position?*
- YES** : Go to step **10BM6**.
- NO** : Repair short circuit in transmission harness or replace neutral position switch.

**10BM6 : CHECK HARNESS BETWEEN ECM AND NEUTRAL POSITION SWITCH CONNECTOR.**

Measure resistance between ECM and chassis ground.

**Connector & terminal**  
(B135) No. 26 (+) — Chassis ground (-):

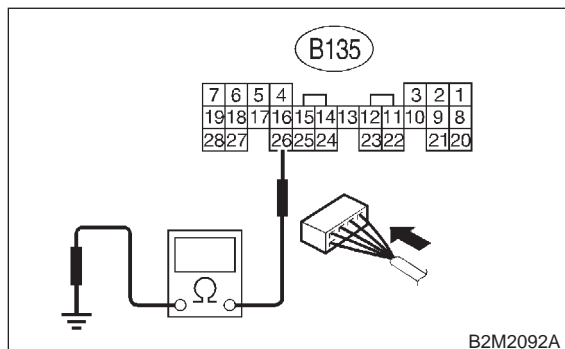

- CHECK** : Is the resistance less than 10 Ω?
- YES** : Repair ground short circuit in harness between ECM and transmission harness connector.
- NO** : Go to step 10BM7.

**10BM7 : CHECK POOR CONTACT.**

Check poor contact in transmission harness connector. <Ref. to FOREWORD [T3C1].>

- CHECK** : Is there poor contact in transmission harness connector?
- YES** : Repair poor contact in transmission harness connector.
- NO** : Contact with SOA service.

**NOTE:**

Inspection by DTM is required, because probable cause is deterioration of multiple parts.

**10BM8 : CHECK DTC P0705 ON DISPLAY.**

- CHECK** : Does the Subaru Select Monitor or OBD-II general scan tool indicate DTC P0705?
- YES** : Inspect DTC P0705 using "10. Diagnostics Chart with Trouble Code". <Ref. to 2-7 [T10A0].>
- NO** : Go to step 10BM9.

**10BM9 : CHECK INPUT SIGNAL FOR ECM.**

- 1) Turn ignition switch to ON.
- 2) Measure voltage between ECM and chassis ground in select lever "N" and "P" positions.

**Connector & terminal**  
(B135) No. 26 (+) — Chassis ground (-):

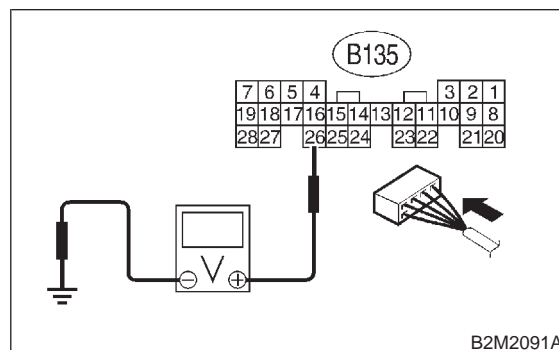

- CHECK** : Is the voltage less than 1 V?
- YES** : Go to step 10BM10.
- NO** : Go to step 10BM12.

**10BM10 : CHECK INPUT SIGNAL FOR ECM.**

Measure voltage between ECM and chassis ground in select lever except for "N" and "P" positions.

**Connector & terminal**  
(B135) No. 26 (+) — Chassis ground (-):

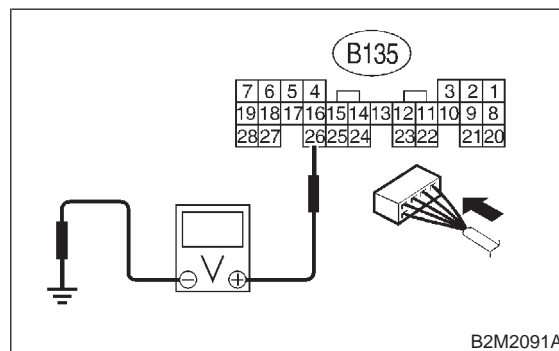

- CHECK** : Is the voltage between 4.5 and 5.5 V?
- YES** : Go to step 10BM11.
- NO** : Go to step 10BM12.

**10BM11 : CHECK POOR CONTACT.**

Check poor contact in ECM connector. <Ref. to FOREWORD [T3C1].>

- CHECK** : *Is there poor contact in ECM connector?*
- YES** : Repair poor contact in ECM connector.
- NO** : Contact with SOA service.

**NOTE:**  
Inspection by DTM is required, because probable cause is deterioration of multiple parts.

**10BM12 : CHECK INPUT SIGNAL FOR ECM.**

Measure voltage between ECM and chassis ground.

**Connector & terminal**  
**(B135) No. 26 (+) — Chassis ground (-):**

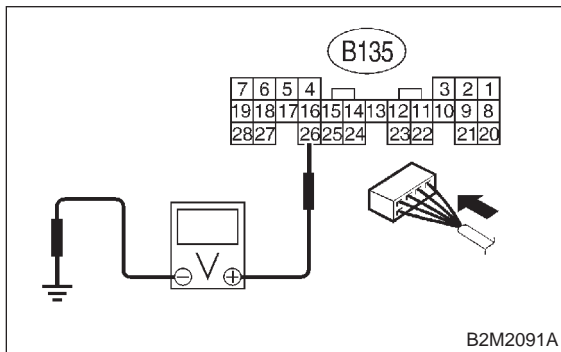

- CHECK** : *Is the voltage more than 10 V?*
- YES** : Repair battery short circuit in harness between ECM and inhibitor switch connector.
- NO** : Go to step **10BM13**.

**10BM13 : CHECK HARNESS BETWEEN ECM AND INHIBITOR SWITCH CONNECTOR.**

- 1) Turn ignition switch to OFF.
- 2) Disconnect connectors from ECM and inhibitor switch.
- 3) Measure resistance of harness between ECM and inhibitor switch connector.

**Connector & terminal**  
**(B135) No. 26 — (T7) No. 12:**

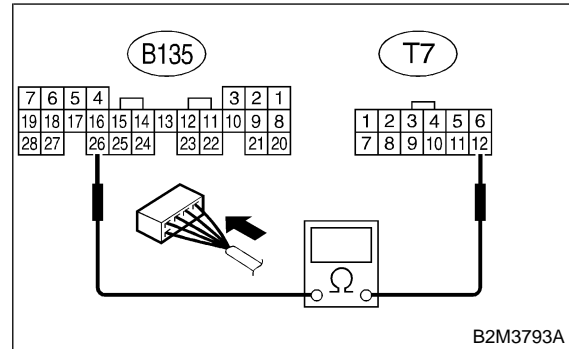

- CHECK** : *Is the resistance less than 1 Ω?*
- YES** : Go to step **10BM14**.
- NO** : Repair harness and connector.

**NOTE:**  
In this case, repair the following:

- Open circuit in harness between ECM and inhibitor switch connector
- Poor contact in coupling connector (B12)
- Poor contact in inhibitor switch connector
- Poor contact in ECM connector

**10BM14 : CHECK INHIBITOR SWITCH GROUND LINE.**

Measure resistance of harness between inhibitor switch connector and engine ground.

**Connector & terminal**

**(T7) No. 7 — Engine ground:**

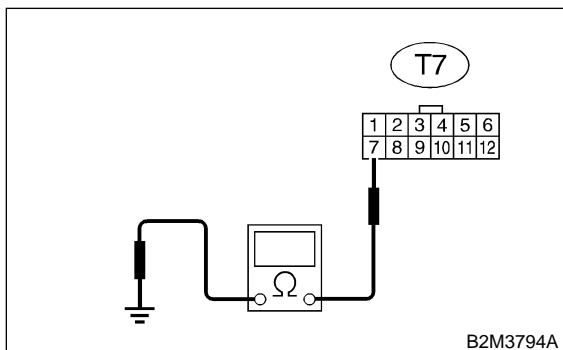

- CHECK** : *Is the resistance less than 5 Ω?*
- YES** : Go to step **10BM15**.
- NO** : Repair open circuit in harness between inhibitor switch connector and starter motor ground line.

**NOTE:**

In this case, repair the following:

- Open circuit in harness between inhibitor switch connector and starter motor ground line
- Poor contact in starter motor connector
- Poor contact in starter motor ground
- Starter motor

**10BM15 : CHECK INHIBITOR SWITCH.**

Measure resistance between inhibitor switch connector receptacle's terminals in select lever "N" and "P" positions.

**Terminals**

**No. 7 — No. 12:**

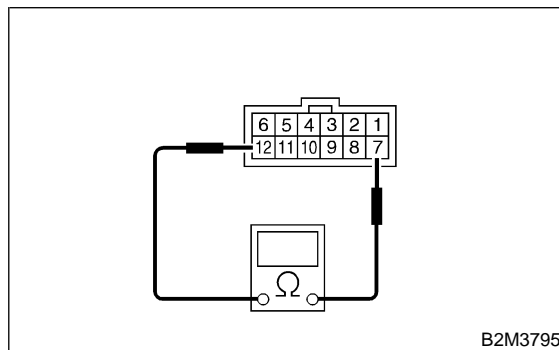

- CHECK** : *Is the resistance less than 1 Ω?*
- YES** : Go to step **10BM16**.
- NO** : Replace inhibitor switch. <Ref. to 3-2 [W2C0].>

**10BM16 : CHECK SELECTOR CABLE CONNECTION.**

- CHECK** : *Is there any fault in selector cable connection to inhibitor switch?*
- YES** : Repair selector cable connection. <Ref. to 3-2 [W2A0].>
- NO** : Contact with SOA service.

**NOTE:**

Inspection by DTM is required, because probable cause is deterioration of multiple parts.

**MEMO:**

**BN: DTC P1103 — ENGINE TORQUE CONTROL SIGNAL 1 CIRCUIT MALFUNCTION —**

- **DTC DETECTING CONDITION:**
  - Two consecutive driving cycles with fault
- **TROUBLE SYMPTOM:**
  - Excessive shift shock

**CAUTION:**

After repair or replacement of faulty parts, conduct CLEAR MEMORY MODE <Ref. to 2-7 [T3D0].> and INSPECTION MODE <Ref. to 2-7 [T3E0].>

● **WIRING DIAGRAM:**

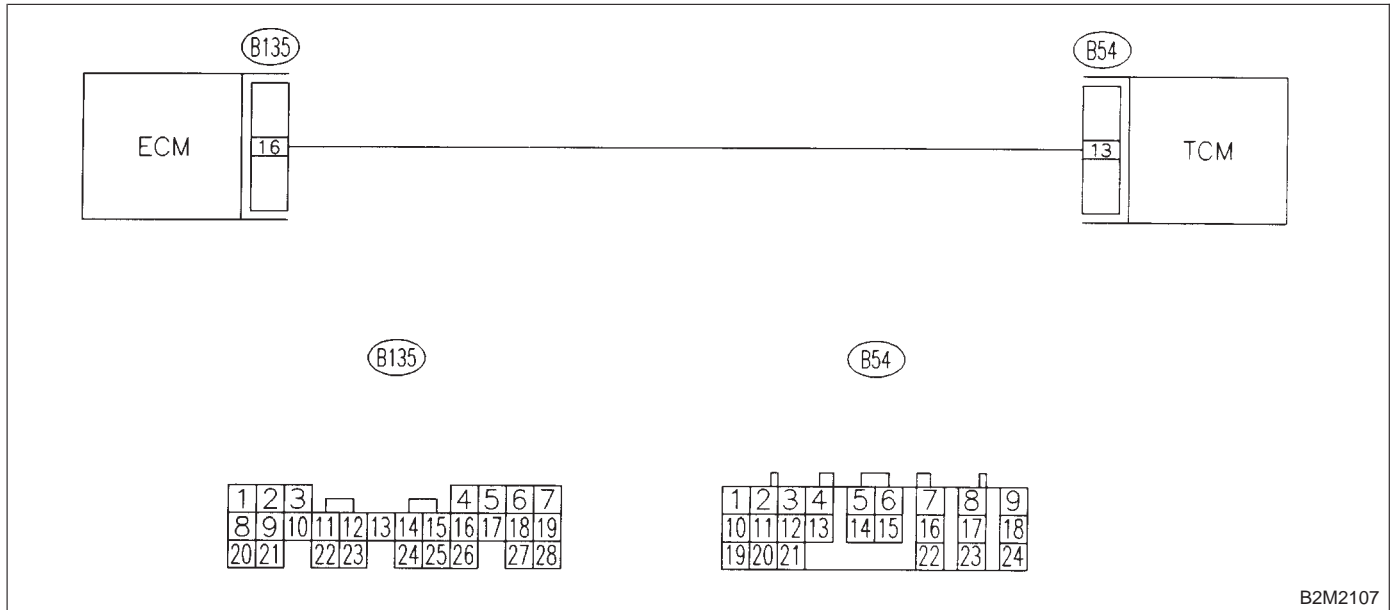

B2M2107

**10BN1 : CHECK INPUT SIGNAL FOR ECM.**

- 1) Turn ignition switch to ON.
- 2) Measure voltage between ECM and chassis ground.

**Connector & terminal**  
**(B135) No. 16 (+) — Chassis ground (-):**

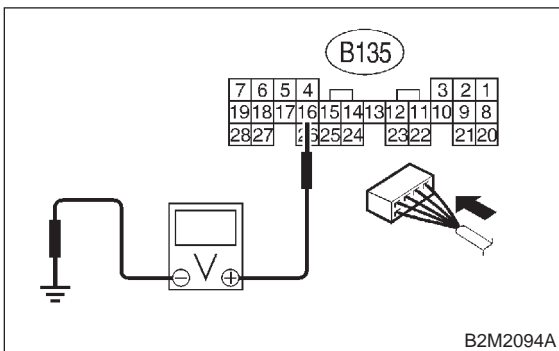

B2M2094A

- CHECK** : Is the voltage more than 4.5 V?
- YES** : Go to step 10BN2.
- NO** : Go to step 10BN4.

**10BN2 : CHECK INPUT SIGNAL FOR ECM.**

Measure voltage between ECM and chassis ground.

**Connector & terminal**  
**(B135) No. 16 (+) — Chassis ground (-):**

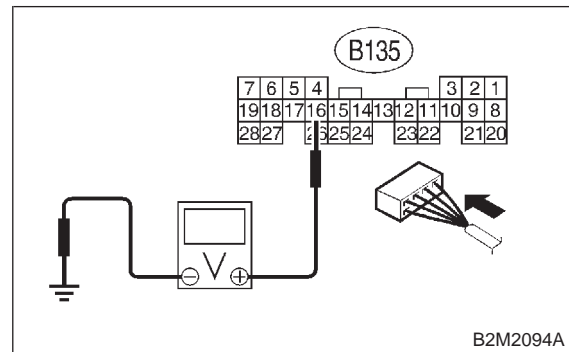

B2M2094A

- CHECK** : Is the voltage more than 10 V?
- YES** : Repair battery short circuit in harness between ECM and TCM connector.
- NO** : Go to step 10BN3.

**10BN3 : CHECK POOR CONTACT.**

Check poor contact in ECM connector. <Ref. to FOREWORD [T3C1].>

- CHECK** : *Is there poor contact in ECM connector?*
- YES** : Repair poor contact in ECM connector.
- NO** : Replace ECM. <Ref. to 2-7 [W17A0].>

**10BN4 : CHECK HARNESS BETWEEN ECM AND TCM CONNECTOR.**

- 1) Turn ignition switch to OFF.
- 2) Disconnect connectors from ECM and TCM.
- 3) Measure resistance of harness between ECM and TCM connector.

**Connector & terminal**  
(B135) No. 16 — (B54) No. 13:

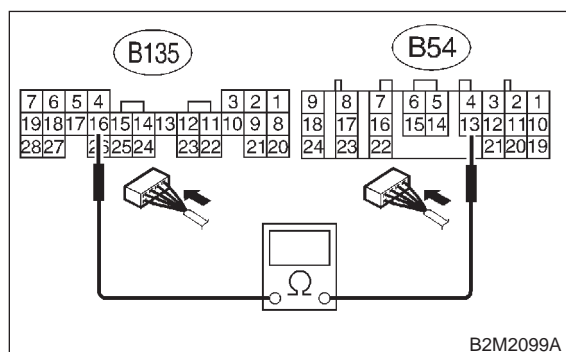

- CHECK** : *Is the resistance less than 1 Ω?*
- YES** : Go to step 10BN5.
- NO** : Repair open circuit in harness between ECM and TCM connector.

**10BN5 : CHECK HARNESS BETWEEN ECM AND TCM CONNECTOR.**

Measure resistance of harness between ECM and chassis ground.

**Connector & terminal**  
(B135) No. 16 — Chassis ground:

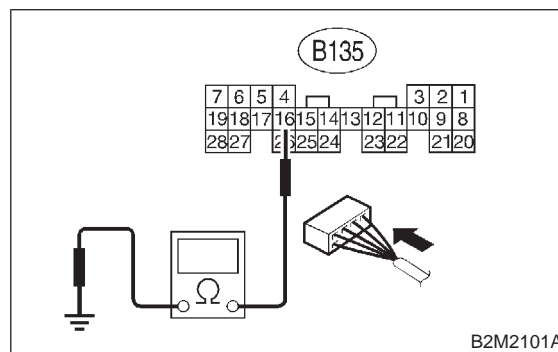

- CHECK** : *Is the resistance less than 10 Ω?*
- YES** : Repair ground short circuit in harness between ECM and TCM connector.
- NO** : Go to step 10BN6.

**10BN6 : CHECK POOR CONTACT.**

Check poor contact in TCM connector. <Ref. to FOREWORD [T3C1].>

- CHECK** : *Is there poor contact in TCM connector?*
- YES** : Repair poor contact in TCM connector.
- NO** : Replace TCM. <Ref. to 3-2 [W23A0].>



**BO: DTC P1106 — ENGINE TORQUE CONTROL SIGNAL 2 CIRCUIT MALFUNCTION —**

- **DTC DETECTING CONDITION:**
  - Two consecutive driving cycles with fault
- **TROUBLE SYMPTOM:**
  - Excessive shift shock

**CAUTION:**

After repair or replacement of faulty parts, conduct CLEAR MEMORY MODE <Ref. to 2-7 [T3D0].> and INSPECTION MODE <Ref. to 2-7 [T3E0].>.

● **WIRING DIAGRAM:**

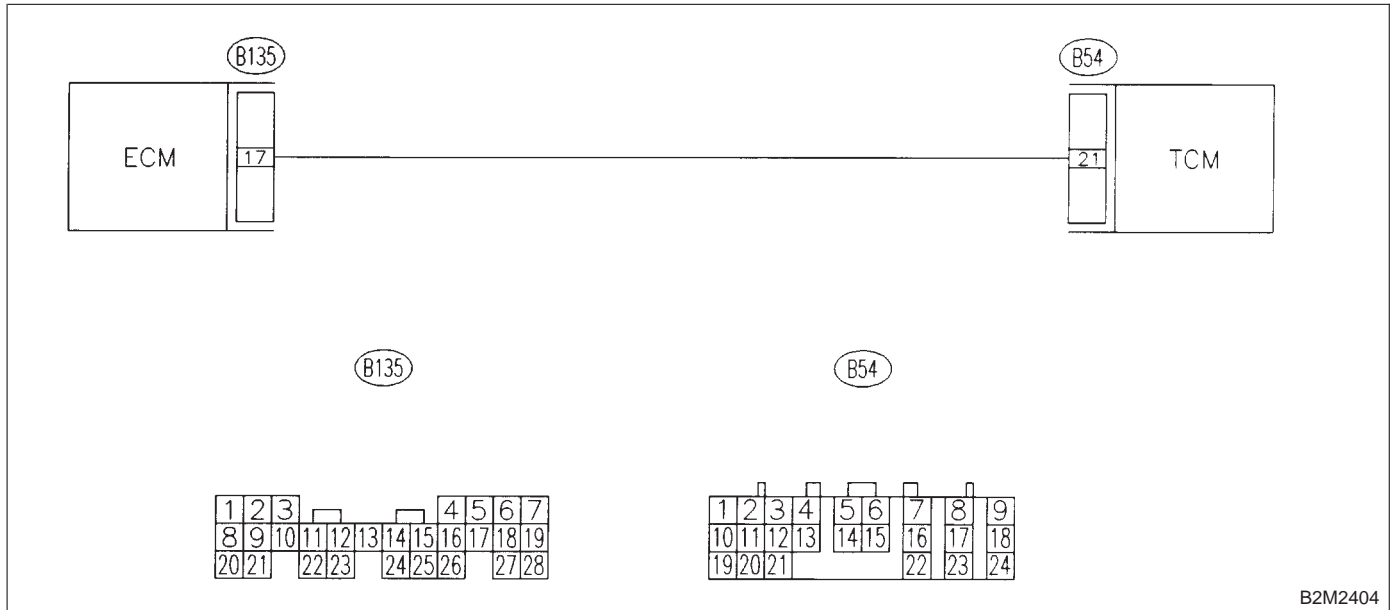

**10BO1 : CHECK INPUT SIGNAL FOR ECM.**

- 1) Turn ignition switch to ON.
- 2) Measure voltage between ECM and chassis ground.

**Connector & terminal**  
**(B135) No. 17 (+) — Chassis ground (-):**

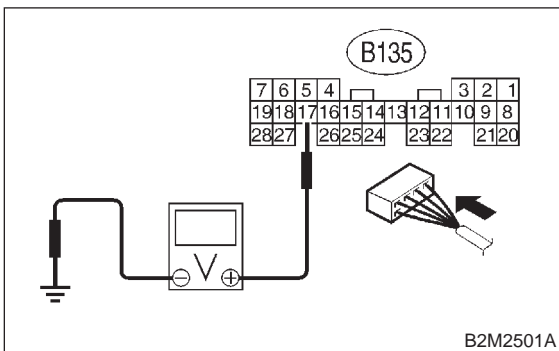

- CHECK** : Is the voltage more than 4.5 V?
- YES** : Go to step 10BO2.
- NO** : Go to step 10BO4.

**10BO2 : CHECK INPUT SIGNAL FOR ECM.**

Measure voltage between ECM and chassis ground.

**Connector & terminal**  
**(B135) No. 17 (+) — Chassis ground (-):**

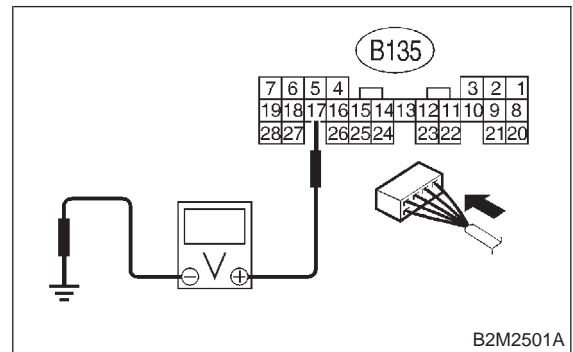

- CHECK** : Is the voltage more than 10 V?
- YES** : Repair battery short circuit in harness between ECM and TCM connector.
- NO** : Go to step 10BO3.

**10B03 : CHECK POOR CONTACT.**

Check poor contact in ECM connector. <Ref. to FOREWORD [T3C1].>

- CHECK** : *Is there poor contact in ECM connector?*
- YES** : Repair poor contact in ECM connector.
- NO** : Replace ECM. <Ref. to 2-7 [W17A0].>

**10B04 : CHECK HARNESS BETWEEN ECM AND TCM CONNECTOR.**

- 1) Turn ignition switch to OFF.
- 2) Disconnect connectors from ECM and TCM.
- 3) Measure resistance of harness between ECM and TCM connector.

**Connector & terminal**  
(B135) No. 17 — (B54) No. 21:

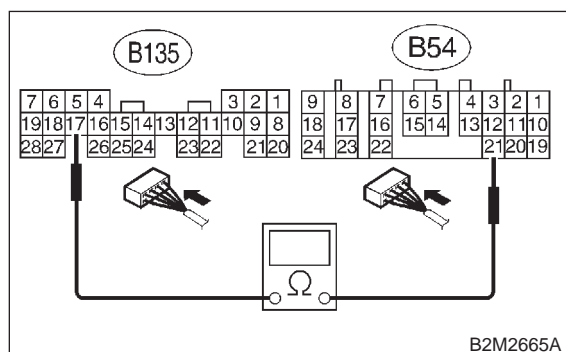

- CHECK** : *Is the resistance less than 1 Ω?*
- YES** : Go to step 10B05.
- NO** : Repair open circuit in harness between ECM and TCM connector.

**10B05 : CHECK HARNESS BETWEEN ECM AND TCM CONNECTOR.**

Measure resistance of harness between ECM and chassis ground.

**Connector & terminal**  
(B135) No. 17 — Chassis ground:

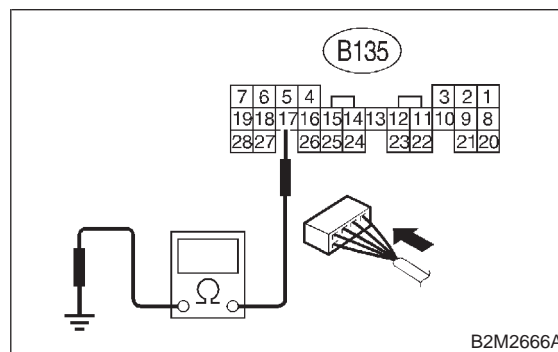

- CHECK** : *Is the resistance less than 10 Ω?*
- YES** : Repair ground short circuit in harness between ECM and TCM connector.
- NO** : Go to step 10B06.

**10B06 : CHECK POOR CONTACT.**

Check poor contact in TCM connector. <Ref. to FOREWORD [T3C1].>

- CHECK** : *Is there poor contact in TCM connector?*
- YES** : Repair poor contact in TCM connector.
- NO** : Replace TCM. <Ref. to 3-2 [W23A0].>

**BP: DTC P1110 — ATMOSPHERIC PRESSURE SENSOR CIRCUIT LOW INPUT —**

- **DTC DETECTING CONDITION:**
  - Immediately at fault recognition

**CAUTION:**

After repair or replacement of faulty parts, conduct CLEAR MEMORY MODE <Ref. to 2-7 [T3D0].> and INSPECTION MODE <Ref. to 2-7 [T3E0].>.

● **WIRING DIAGRAM:**

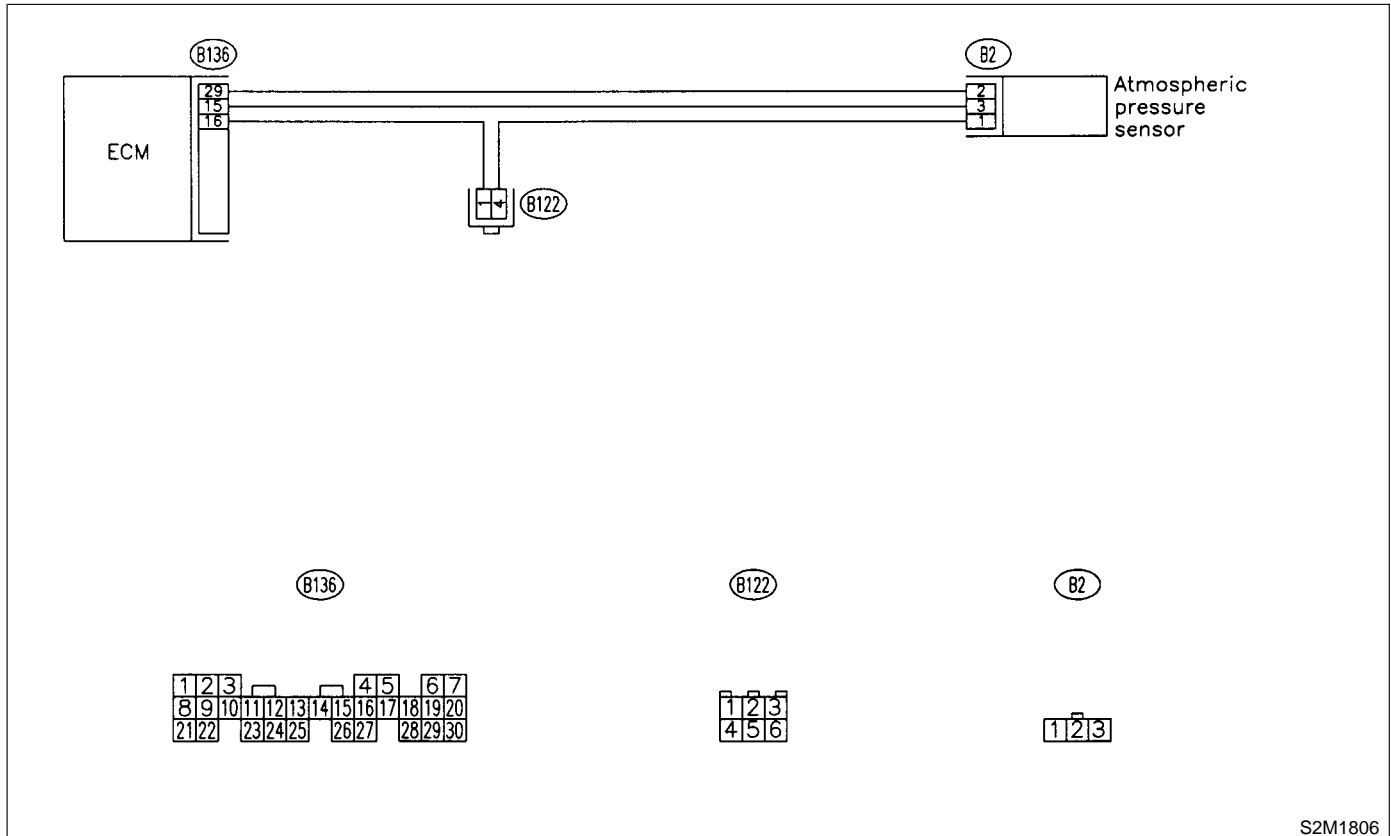

S2M1806

**10BP1 : CHECK CURRENT DATA.**

- 1) Start engine.
- 2) Read the data of intake manifold absolute pressure signal using Subaru Select Monitor or OBD-II general scan tool.

NOTE:

- Subaru Select Monitor  
For detailed operation procedure, refer to the "READ CURRENT DATA SHOWN ON DISPLAY FOR ENGINE". <Ref. to 2-7 [T3C4].>
- OBD-II general scan tool  
For detailed operation procedures, refer to the OBD-II General Scan Tool Instruction Manual.

**CHECK** : *Is the value less than 0 kPa (0 mmHg, 0 inHg)?*

**YES** : Go to step 10BP3.

**NO** : Go to step 10BP2.

**10BP2 : CHECK POOR CONTACT.**

Check poor contact in ECM and pressure sensor connector. <Ref. to 2-7 [T3C8].>

**CHECK** : *Is there poor contact in ECM or pressure sensor connector?*

**YES** : Repair poor contact in ECM or atmospheric pressure sensor connector.

**NO** : Even if MIL lights up, the circuit has returned to a normal condition at this time.

**10BP3 : CHECK INPUT SIGNAL FOR ECM.**

Measure voltage between ECM connector and chassis ground.

**Connector & terminal**  
*(B136) No. 15 (+) — Chassis ground (-):*

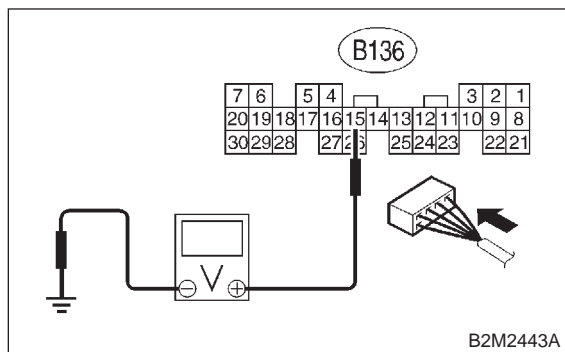

**CHECK** : *Is the voltage more than 4.5 V?*

**YES** : Go to step 10BP5.

**NO** : Go to step 10BP4.

**10BP4 : CHECK INPUT SIGNAL FOR ECM.**

Measure voltage between ECM connector and chassis ground.

**Connector & terminal**  
*(B136) No. 15 (+) — Chassis ground (-):*

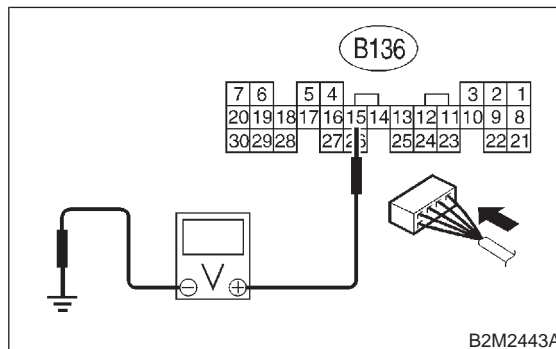

**CHECK** : *Does the voltage change more than 4.5 V by shaking harness and connector of ECM while monitoring the value with voltage meter?*

**YES** : Repair poor contact in ECM connector.

**NO** : Contact with SOA service.

NOTE:

Inspection by DTM is required, because probable cause is deterioration of multiple parts.

**10BP5 : CHECK INPUT SIGNAL FOR ECM.**

Measure voltage between ECM and chassis ground.

**Connector & terminal**  
*(B136) No. 29 (+) — Chassis ground (-):*

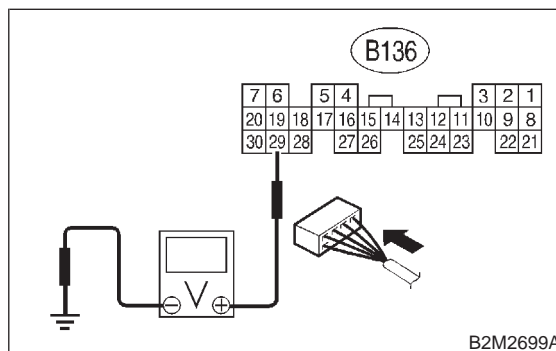

**CHECK** : *Is the voltage less than 0.2 V?*

**YES** : Go to step 10BP7.

**NO** : Go to step 10BP6.

**10BP6 : CHECK INPUT SIGNAL FOR ECM.  
(USING SUBARU SELECT MONI-  
TOR.)**

Read data of atmospheric absolute pressure signal using Subaru Select Monitor.

NOTE:

- Subaru Select Monitor

For detailed operation procedure, refer to the "READ CURRENT DATA SHOWN ON DISPLAY FOR ENGINE". <Ref. to 2-7 [T3C4].>

**CHECK** : *Does the value change more than 0 kPa (0 mmHg, 0 inHg) by shaking harness and connector of ECM while monitoring the value with Subaru select monitor?*

- YES** : Repair poor contact in ECM connector.  
**NO** : Go to step **10BP7**.

**10BP7 : CHECK HARNESS BETWEEN ECM  
AND ATMOSPHERIC PRESSURE  
SENSOR CONNECTOR.**

- 1) Turn ignition switch to OFF.
- 2) Disconnect connector from atmospheric pressure sensor.
- 3) Turn ignition switch to ON.
- 4) Measure voltage between atmospheric pressure sensor connector and engine ground.

**Connector & terminal**

**(B2) No. 3 (+) — Engine ground (-):**

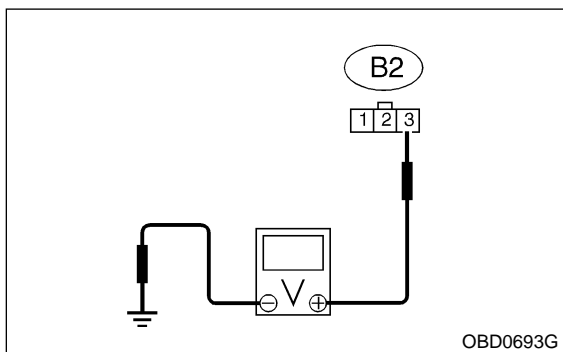

- CHECK** : *Is the voltage more than 4.5 V?*  
**YES** : Go to step **10BP8**.  
**NO** : Repair harness and connector.

NOTE:

In this case, repair the following:

- Open circuit in harness between ECM and atmospheric pressure sensor connector
- Poor contact in joint connector (B122)

**10BP8 : CHECK HARNESS BETWEEN ECM  
AND ATMOSPHERIC PRESSURE  
SENSOR CONNECTOR.**

- 1) Turn ignition switch to OFF.
- 2) Disconnect connector from ECM.
- 3) Measure resistance of harness between ECM and pressure sensor connector.

**Connector & terminal**

**(B136) No. 16 — (B2) No. 1:**

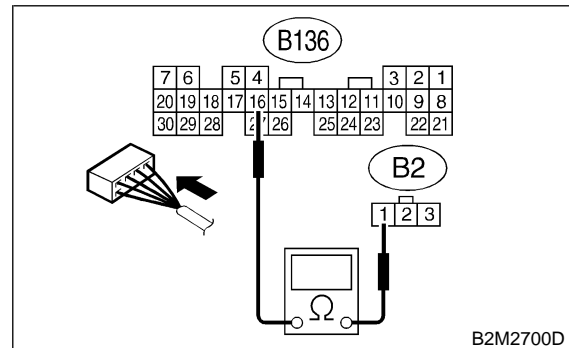

- CHECK** : *Is the resistance less than 1 Ω?*  
**YES** : Go to step **10BP9**.  
**NO** : Repair harness and connector.

NOTE:

In this case, repair the following:

- Open circuit in harness between ECM and pressure sensor connector

**10BP9 : CHECK HARNESS BETWEEN ECM AND ATMOSPHERIC PRESSURE SENSOR CONNECTOR.**

Measure resistance of harness between pressure sensor connector and engine ground.

**Connector & terminal**

**(B2) No. 2 — Engine ground:**

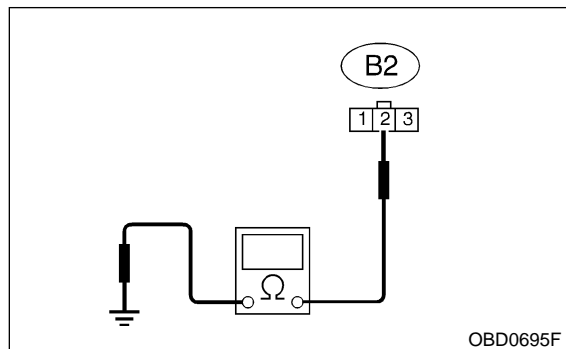

- CHECK** : **Is the resistance more than 500 kΩ?**
- YES** : Go to step **10BP10**.
- NO** : Repair ground short circuit in harness between ECM and pressure sensor connector.

**10BP10 : CHECK POOR CONTACT.**

Check poor contact in pressure sensor connector.  
<Ref. to FOREWORD [T3C1].>

- CHECK** : **Is there poor contact in pressure sensor connector?**
- YES** : Repair poor contact in atmospheric pressure sensor connector.
- NO** : Replace atmospheric pressure sensor.  
<Ref. to 2-7 [W12A0].>

**BQ: DTC P1111 — ATMOSPHERIC PRESSURE SENSOR CIRCUIT HIGH INPUT —**

- **DTC DETECTING CONDITION:**
  - Immediately at fault recognition

**CAUTION:**

After repair or replacement of faulty parts, conduct CLEAR MEMORY MODE <Ref. to 2-7 [T3D0].> and INSPECTION MODE <Ref. to 2-7 [T3E0].>.

● **WIRING DIAGRAM:**

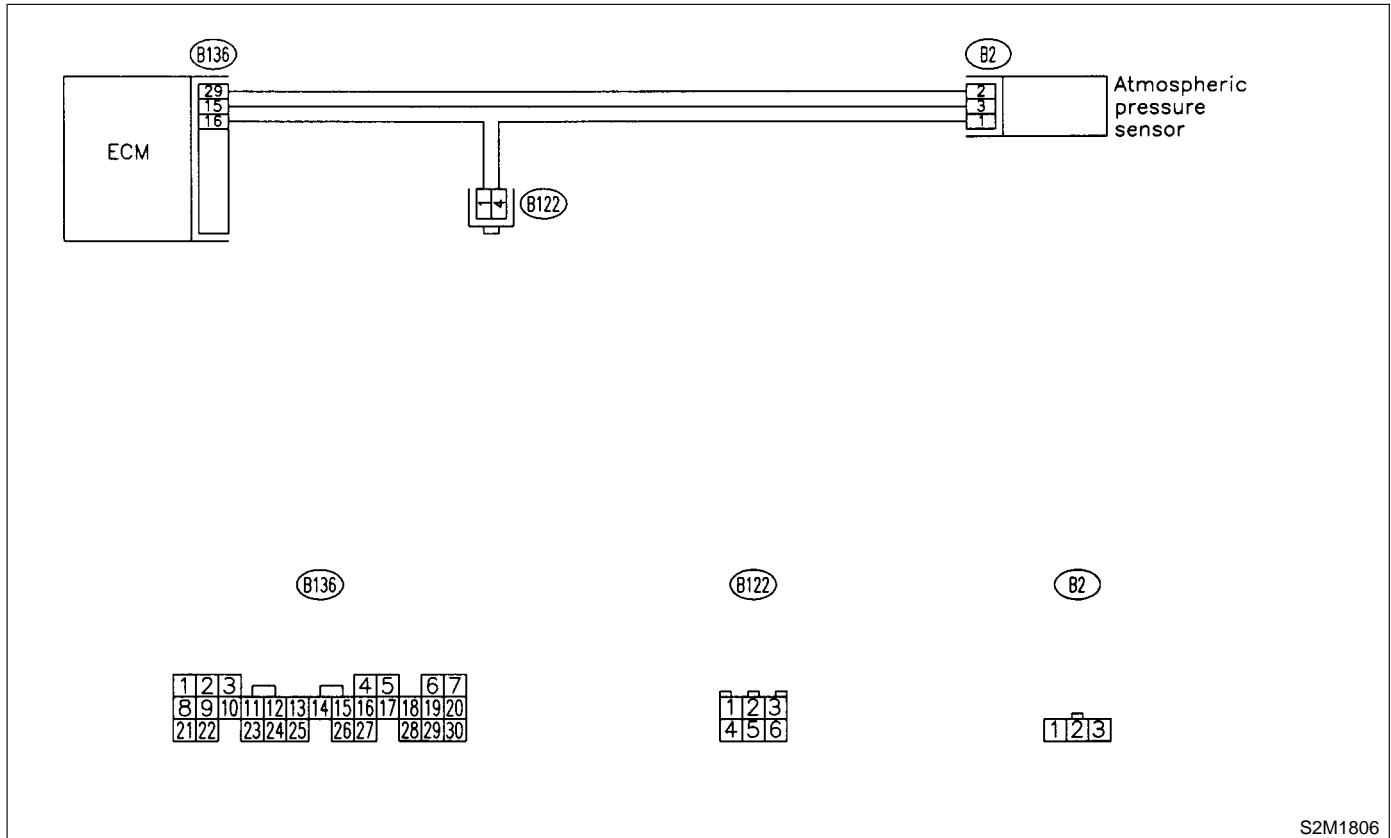

S2M1806

**10BQ1 : CHECK CURRENT DATA.**

- 1) Start engine.
- 2) Read the data of intake manifold absolute pressure signal using Subaru Select Monitor or OBD-II general scan tool.

NOTE:

- Subaru Select Monitor  
For detailed operation procedure, refer to the "READ CURRENT DATA SHOWN ON DISPLAY FOR ENGINE". <Ref. to 2-7 [T3C4].>
- OBD-II general scan tool  
For detailed operation procedures, refer to the OBD-II General Scan Tool Instruction Manual.

**CHECK** : *Is the value more than 140 kPa (1,050 mmHg, 41.34 inHg)?*

**YES** : Go to step 10BQ9.

**NO** : Go to step 10BQ2.

**10BQ2 : CHECK INPUT SIGNAL FOR ECM.**

Measure voltage between ECM connector and chassis ground.

**Connector & terminal**  
*(B136) No. 15 (+) — Chassis ground (-):*

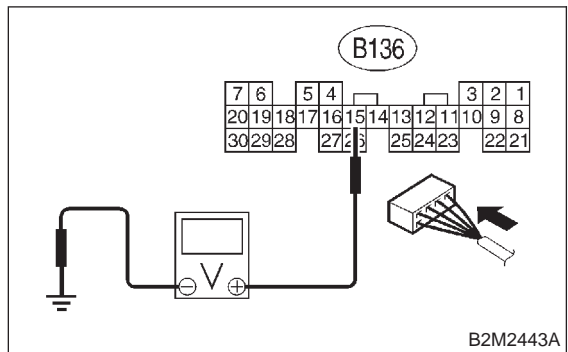

**CHECK** : *Is the voltage more than 4.5 V?*

**YES** : Go to step 10BQ4.

**NO** : Go to step 10BQ3.

**10BQ3 : CHECK INPUT SIGNAL FOR ECM.**

Measure voltage between ECM connector and chassis ground.

**Connector & terminal**  
*(B136) No. 15 (+) — Chassis ground (-):*

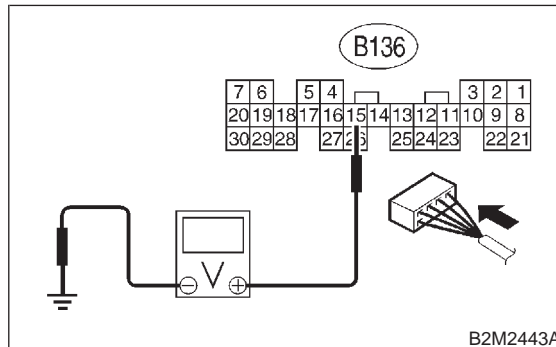

**CHECK** : *Does the voltage change more than 4.5 V by shaking harness and connector of ECM while monitoring the value with voltage meter?*

**YES** : Repair poor contact in ECM connector.

**NO** : Contact with SOA service.

NOTE:

Inspection by DTM is required, because probable cause is deterioration of multiple parts.

**10BQ4 : CHECK INPUT SIGNAL FOR ECM.**

Measure voltage between ECM connector and chassis ground.

**Connector & terminal**  
*(B136) No. 29 (+) — Chassis ground (-):*

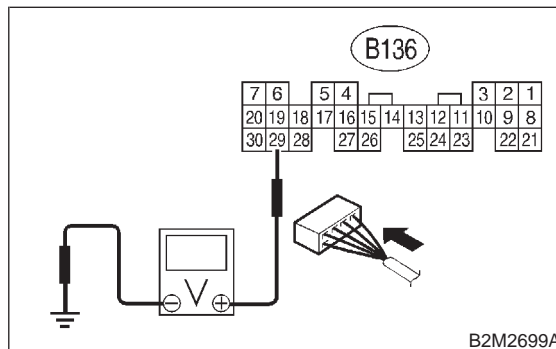

**CHECK** : *Is the voltage less than 0.2 V?*

**YES** : Go to step 10BQ6.

**NO** : Go to step 10BQ5.



**10BQ5 : CHECK INPUT SIGNAL FOR ECM.  
(USING SUBARU SELECT MONI-  
TOR.)**

Read data of atmospheric absolute pressure signal using Subaru Select Monitor.

**NOTE:**

- Subaru Select Monitor

For detailed operation procedure, refer to the "READ CURRENT DATA SHOWN ON DISPLAY FOR ENGINE". <Ref. to 2-7 [T3C4].>

**CHECK** : *Does the value change more than 0 kPa (0 mmHg, 0 inHg) by shaking harness and connector of ECM while monitoring the value with Subaru select monitor?*

- YES** : Repair poor contact in ECM connector.  
**NO** : Go to step **10BQ6**.

**10BQ6 : CHECK HARNESS BETWEEN ECM  
AND ATMOSPHERIC PRESSURE  
SENSOR CONNECTOR.**

- 1) Turn ignition switch to OFF.
- 2) Disconnect connector from atmospheric pressure sensor.
- 3) Turn ignition switch to ON.
- 4) Measure voltage between atmospheric pressure sensor connector and engine ground.

**Connector & terminal**

**(B2) No. 3 (+) — Engine ground (-):**

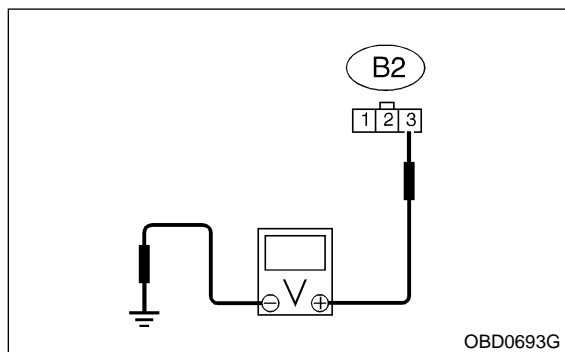

- CHECK** : *Is the voltage more than 4.5 V?*  
**YES** : Go to step **10BQ7**.  
**NO** : Repair harness and connector.

**NOTE:**

In this case, repair the following:

- Open circuit in harness between ECM and atmospheric pressure sensor connector
- Poor contact in joint connector (B122)

**10BQ7 : CHECK HARNESS BETWEEN ECM  
AND ATMOSPHERIC PRESSURE  
SENSOR CONNECTOR.**

- 1) Turn ignition switch to OFF.
- 2) Disconnect connector from ECM.
- 3) Measure resistance of harness between ECM and atmospheric pressure sensor connector.

**Connector & terminal**

**(B136) No. 29 — (B2) No. 2:**

**(B136) No. 16 — (B2) No. 1:**

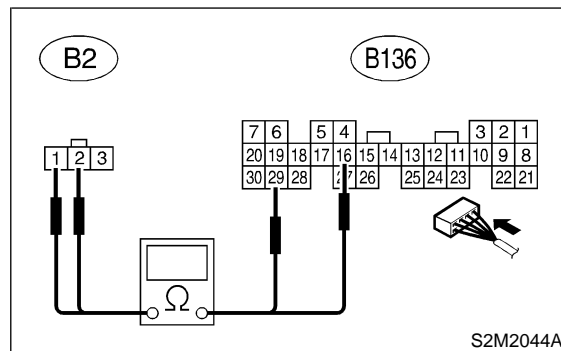

- CHECK** : *Is the resistance less than 1 Ω?*  
**YES** : Go to step **10BQ8**.  
**NO** : Repair harness and connector.

**NOTE:**

In this case, repair the following:

- Open circuit in harness between ECM and pressure sensor connector
- Poor contact in joint connector (B122)

**10BQ8 : CHECK POOR CONTACT.**

Check poor contact in pressure sensor connector.  
<Ref. to FOREWORD [T3C1].>

- CHECK** : *Is there poor contact in pressure sensor connector?*  
**YES** : Repair poor contact in atmospheric pressure sensor connector.  
**NO** : Replace atmospheric pressure sensor.  
<Ref. to 2-7 [W12A0].>

**10BQ9 : CHECK CURRENT DATA.**

- 1) Turn ignition switch to OFF.
- 2) Disconnect connector from atmospheric pressure sensor.
- 3) Turn ignition switch to ON.
- 4) Read data of intake manifold absolute pressure signal using Subaru select monitor or OBD-II general scan tool.

## NOTE:

- Subaru Select Monitor

For detailed operation procedure, refer to the "READ CURRENT DATA SHOWN ON DISPLAY FOR ENGINE". <Ref. to 2-7 [T3C4].>

- OBD-II general scan tool

For detailed operation procedures, refer to the OBD-II General Scan Tool Instruction Manual.

- CHECK** : ***Is the value more than 140 kPa (1,050 mmHg, 41.34 inHg)?***
- YES** : Repair battery short circuit in harness between ECM and atmospheric pressure sensor connector.
- NO** : Replace atmospheric pressure sensor. <Ref. to 2-7 [W12A0].>

## BR: DTC P1112 — ATMOSPHERIC PRESSURE SENSOR CIRCUIT RANGE/ PERFORMANCE PROBLEM —

### ● DTC DETECTING CONDITION:

- Two consecutive driving cycles with fault

### CAUTION:

After repair or replacement of faulty parts, conduct CLEAR MEMORY MODE <Ref. to 2-7 [T3D0].> and INSPECTION MODE <Ref. to 2-7 [T3E0].>.

### ● WIRING DIAGRAM:

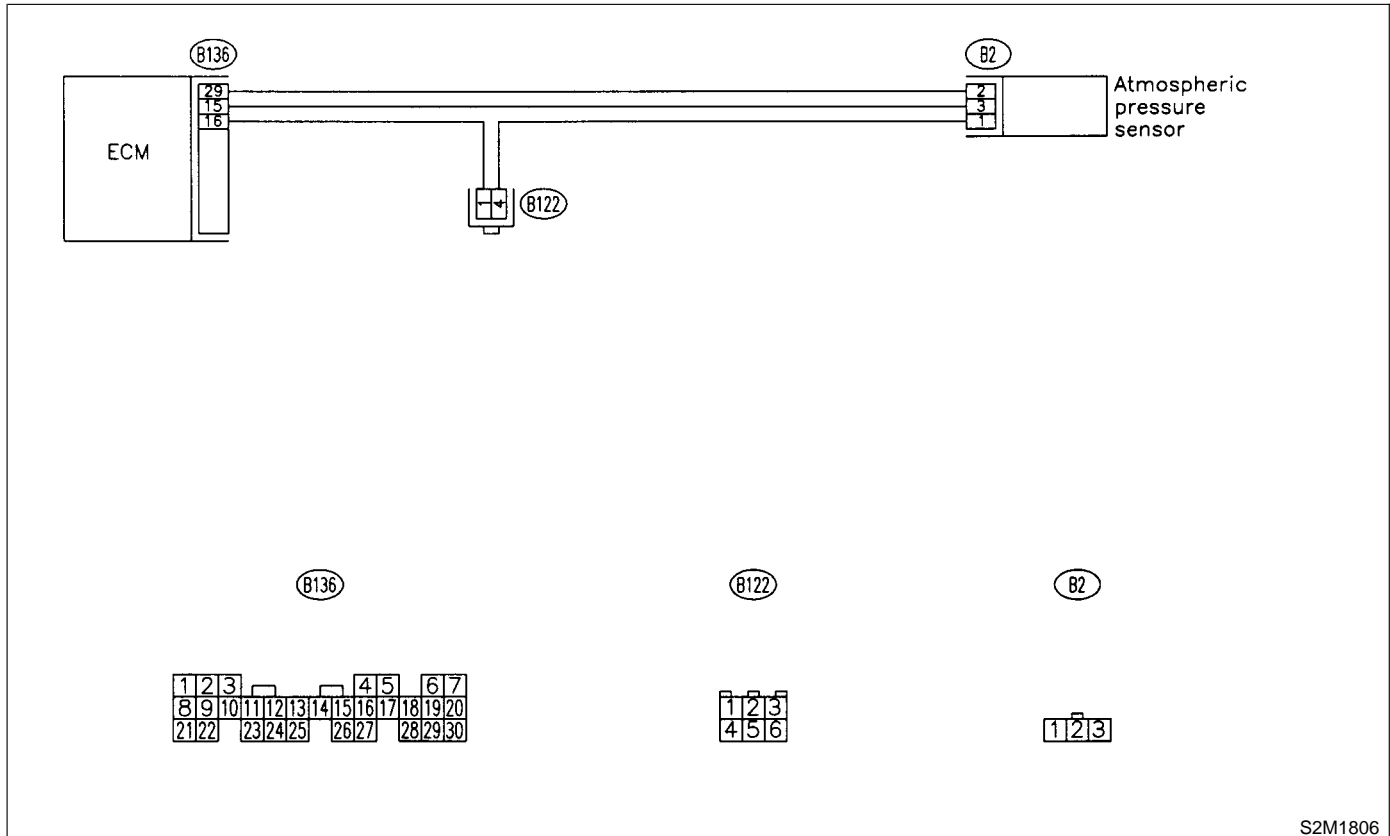

**10BR1 : CHECK ANY OTHER DTC ON DISPLAY.**

**10BR2 : CHECK ATMOSPHERIC PRESSURE SENSOR FILTER.**

### NOTE:

In this case, it is not necessary to inspect DTC P0106.

**CHECK** : *Does the Subaru Select Monitor or OBD-II general scan tool indicate DTC P0106, P0107, P0108, P1110 or P1111?*

**YES** : Inspect DTC P0106, P0107, P0108, P1110 or P1111 using "10. Diagnostics Chart with Trouble Code". <Ref. to 2-7 [T10A0].>

**NO** : Go to step **10BR2**.

- 1) Turn ignition switch to OFF.
- 2) Disconnect connector from atmospheric pressure sensor.
- 3) Remove atmospheric pressure sensor.
- 4) Check atmospheric pressure sensor filter.

**CHECK** : *Is atmospheric pressure sensor filter non-functional? (Check for contamination, damage, water leakage, etc.)*

**YES** : Replace atmospheric pressure sensor filter.

**NO** : Go to step **10BR3**.

**10BR3 : CHECK CURRENT DATA.**

- 1) Turn ignition switch to ON.
- 2) Read data of intake manifold absolute pressure signal using Subaru Select Monitor or OBD-II general scan tool.

## NOTE:

- Subaru Select Monitor

For detailed operation procedure, refer to the "READ CURRENT DATA SHOWN ON DISPLAY FOR ENGINE". <Ref. to 2-7 [T3C4].>

- OBD-II general scan tool

For detailed operation procedures, refer to the OBD-II General Scan Tool Instruction Manual.

**CHECK** : *Is the value between 73.3 kPa (550 mmHg, 21.65 inHg) and 106.6 kPa (800 mmHg, 31.50 inHg)?*

**YES** : Replace atmospheric pressure sensor. <Ref. to 2-7 [W12A0].>

**NO** : Replace intake air temperature and pressure. <Ref. to 2-7 [W11A0].>

**BS: DTC P1115 — ENGINE TORQUE CONTROL CUT SIGNAL CIRCUIT HIGH INPUT —**

● **DTC DETECTING CONDITION:**

- Two consecutive driving cycles with fault

**CAUTION:**

After repair or replacement of faulty parts, conduct CLEAR MEMORY MODE <Ref. to 2-7 [T3D0].> and INSPECTION MODE <Ref. to 2-7 [T3E0].>.

● **WIRING DIAGRAM:**

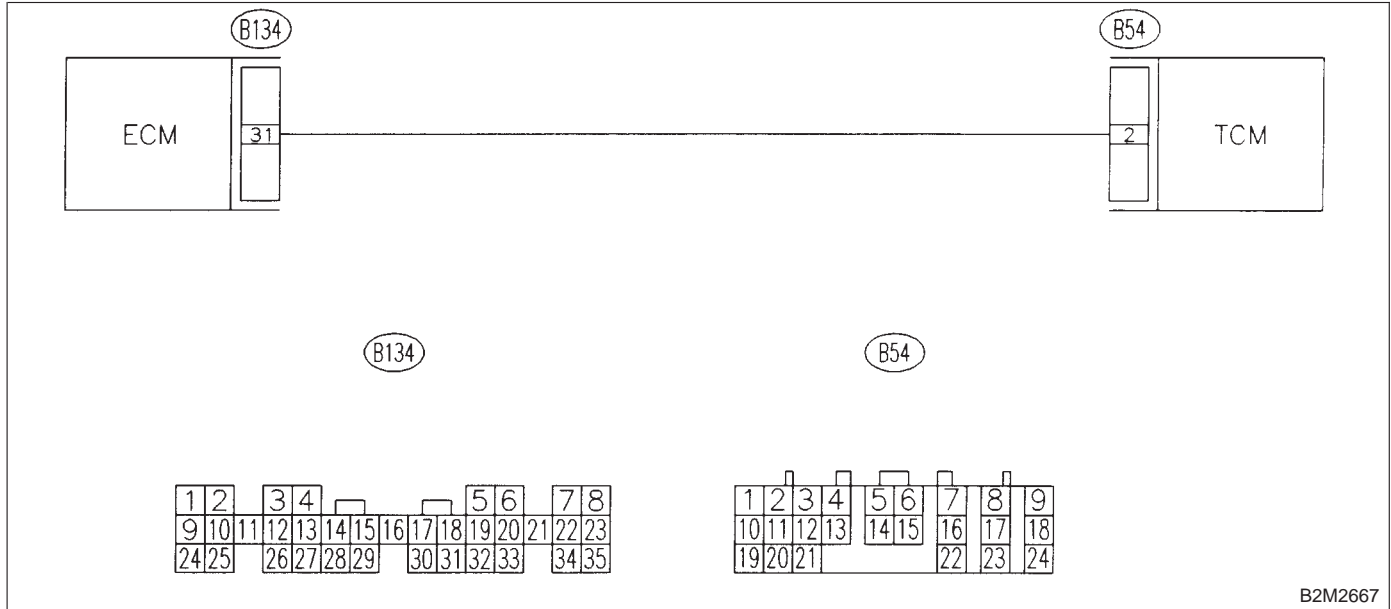

B2M2667

**10BS1 : CHECK OUTPUT SIGNAL FROM ECM.**

- 1) Start engine, and warm-up the engine.
- 2) Turn ignition switch to OFF.
- 3) Disconnect connector from TCM.
- 4) Turn ignition switch to ON.
- 5) Measure voltage between ECM and chassis ground.

**Connector & terminal**

**(B134) No. 31 (+) — Chassis ground (-):**

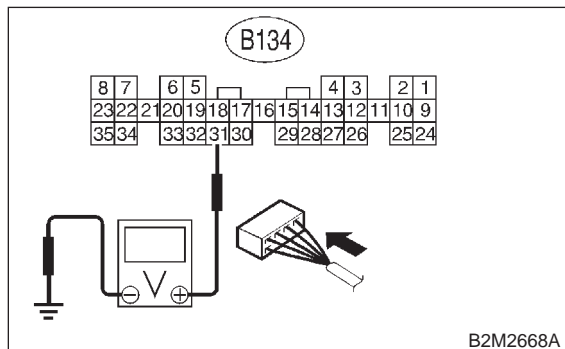

- CHECK** : Is the voltage less than 3 V?
- YES** : Go to step 10BS2.
- NO** : Repair battery short circuit in harness between ECM and TCM connector. After repair, replace ECM. <Ref. to 2-7 [W17A0].>

**10BS2 : CHECK HARNESS BETWEEN ECM AND TCM CONNECTOR.**

- 1) Turn ignition switch to OFF.
- 2) Measure voltage between ECM and chassis ground.

**Connector & terminal**

**(B134) No. 31 (+) — Chassis ground (-):**

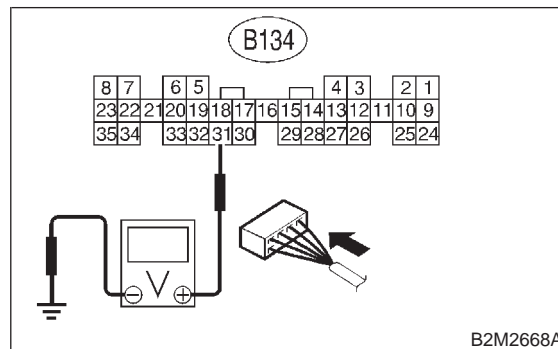

- CHECK** : Does the voltage change more than 10 V by shaking harness and connector of ECM while monitoring the value with voltage meter?
- YES** : Repair battery short circuit in harness between ECM and TCM connector. After repair, replace ECM. <Ref. to 2-7 [W17A0].>
- NO** : Contact with SOA service.

**NOTE:**

Inspection by DTM is required, because probable cause is deterioration of multiple parts.

**BT: DTC P1116 — ENGINE TORQUE CONTROL CUT SIGNAL CIRCUIT LOW INPUT —**

**● DTC DETECTING CONDITION:**

- Two consecutive driving cycles with fault

**CAUTION:**

After repair or replacement of faulty parts, conduct CLEAR MEMORY MODE <Ref. to 2-7 [T3D0].> and INSPECTION MODE <Ref. to 2-7 [T3E0].>

**● WIRING DIAGRAM:**

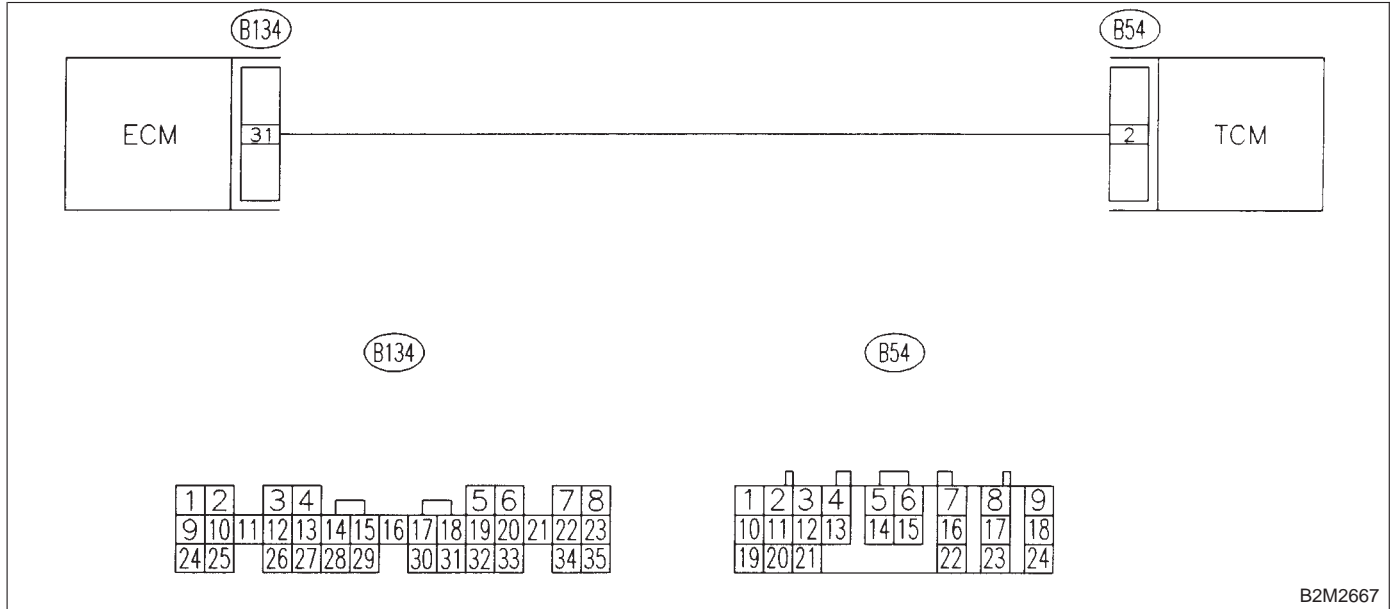

B2M2667

**10BT1 : CHECK OUTPUT SIGNAL FROM ECM.**

- 1) Start engine, and warm-up the engine.
- 2) Turn ignition switch to OFF.
- 3) Turn ignition switch to ON.
- 4) Measure voltage between ECM and chassis ground.

**Connector & terminal**

**(B134) No. 31 (+) — Chassis ground (-):**

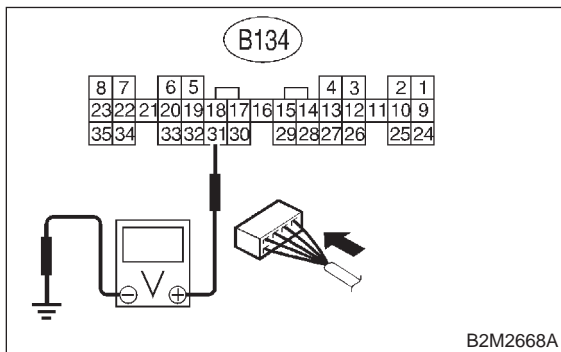

B2M2668A

- CHECK** : Is the voltage more than 3 V?
- YES** : Repair poor contact in ECM connector.
- NO** : Go to step 10BT2.

**10BT2 : CHECK HARNESS BETWEEN ECM AND TCM CONNECTOR.**

- 1) Turn ignition switch to OFF.
- 2) Disconnect connectors from ECM and TCM.
- 3) Measure resistance of harness between ECM and chassis ground.

**Connector & terminal**

**(B134) No. 31 — Chassis ground:**

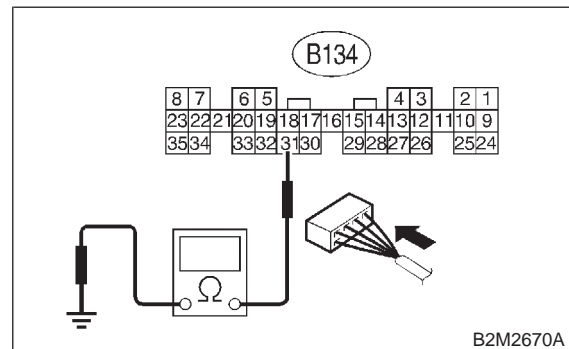

B2M2670A

- CHECK** : Is the resistance less than 10 Ω?
- YES** : Repair ground short circuit in harness between ECM and TCM connector.
- NO** : Go to step 10BT3.

**10BT3 : CHECK HARNESS BETWEEN ECM AND TCM CONNECTOR.**

Measure resistance of harness between ECM and TCM connector.

**Connector & terminal**

**(B134) No. 31 — (B54) No. 2:**

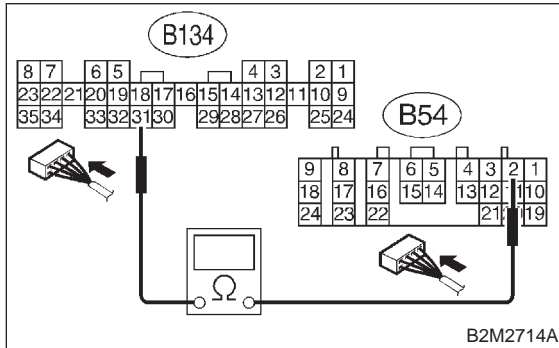

- CHECK** : **Is the resistance less than 1 Ω?**
- YES** : Repair poor contact in ECM or TCM connector.
- NO** : Repair open circuit in harness between ECM and TCM connector.



**BU: DTC P1120 — STARTER SWITCH CIRCUIT HIGH INPUT —**

- **DTC DETECTING CONDITION:**
  - Two consecutive driving cycles with fault
- **TROUBLE SYMPTOM:**
  - Failure of engine to start

**CAUTION:**

After repair or replacement of faulty parts, conduct CLEAR MEMORY MODE <Ref. to 2-7 [T3D0].> and INSPECTION MODE <Ref. to 2-7 [T3E0].>

● **WIRING DIAGRAM:**

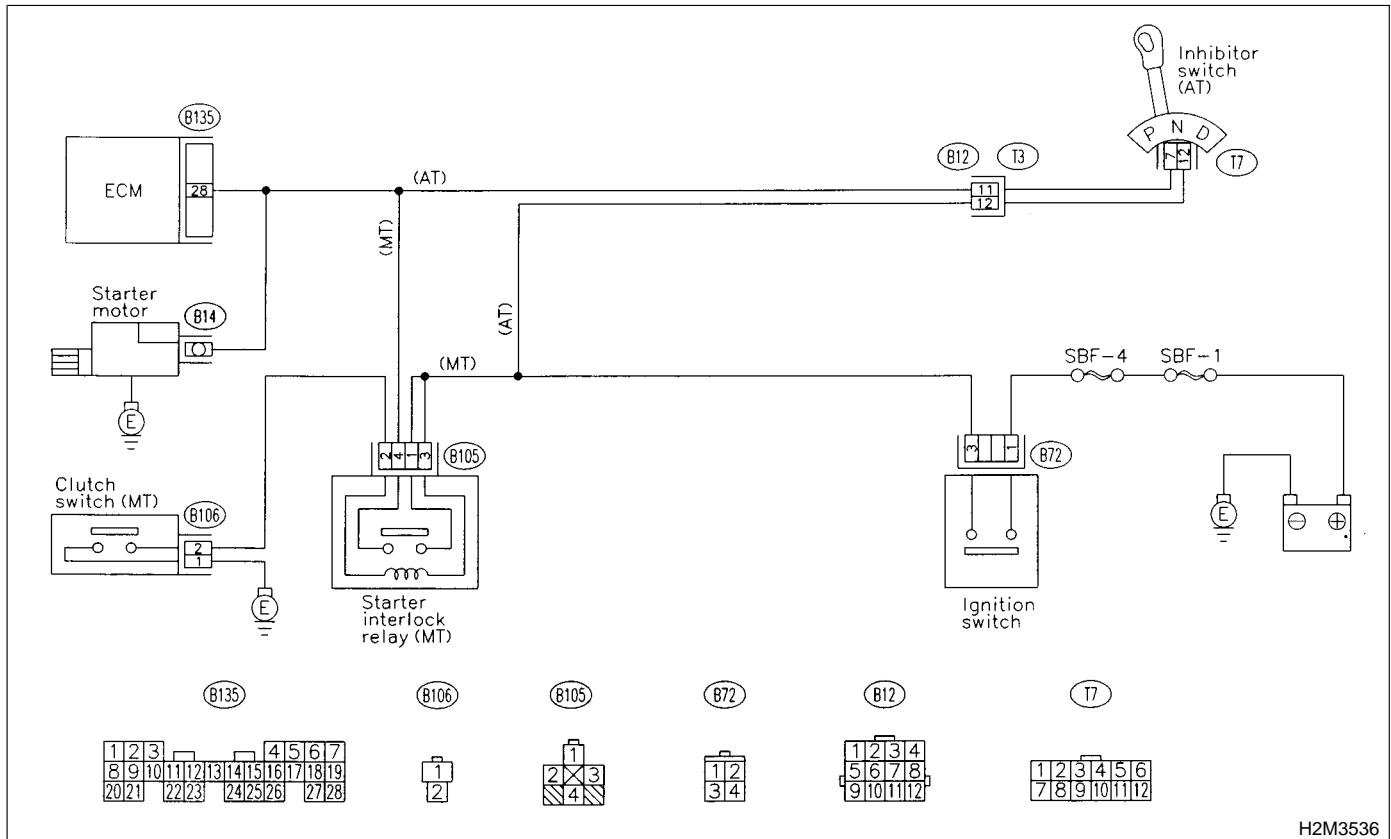

H2M3536

**10BU1 : CHECK OPERATION OF STARTER MOTOR.**

**NOTE:**

- ON AT vehicles, place the inhibitor switch in each position.
- On MT vehicles, depress or release the clutch pedal.

- CHECK** : **Does starter motor operate when ignition switch to "ON"?**
- YES** : Repair battery short circuit in starter motor circuit. After repair, replace ECM. <Ref. to 2-7 [W17A0].>
- NO** : Check starter motor circuit. <Ref. to 2-7 [T8B0].>

**MEMO:**

**BV: DTC P1121 — NEUTRAL POSITION SWITCH CIRCUIT HIGH INPUT [MT VEHICLES] OR NEUTRAL POSITION SWITCH CIRCUIT LOW INPUT [AT VEHICLES] —**

- **DTC DETECTING CONDITION:**
  - Two consecutive driving cycles with fault
- **TROUBLE SYMPTOM:**
  - Erroneous idling

**CAUTION:**

After repair or replacement of faulty parts, conduct CLEAR MEMORY MODE <Ref. to 2-7 [T3D0].> and INSPECTION MODE <Ref. to 2-7 [T3E0].>

● **WIRING DIAGRAM:**

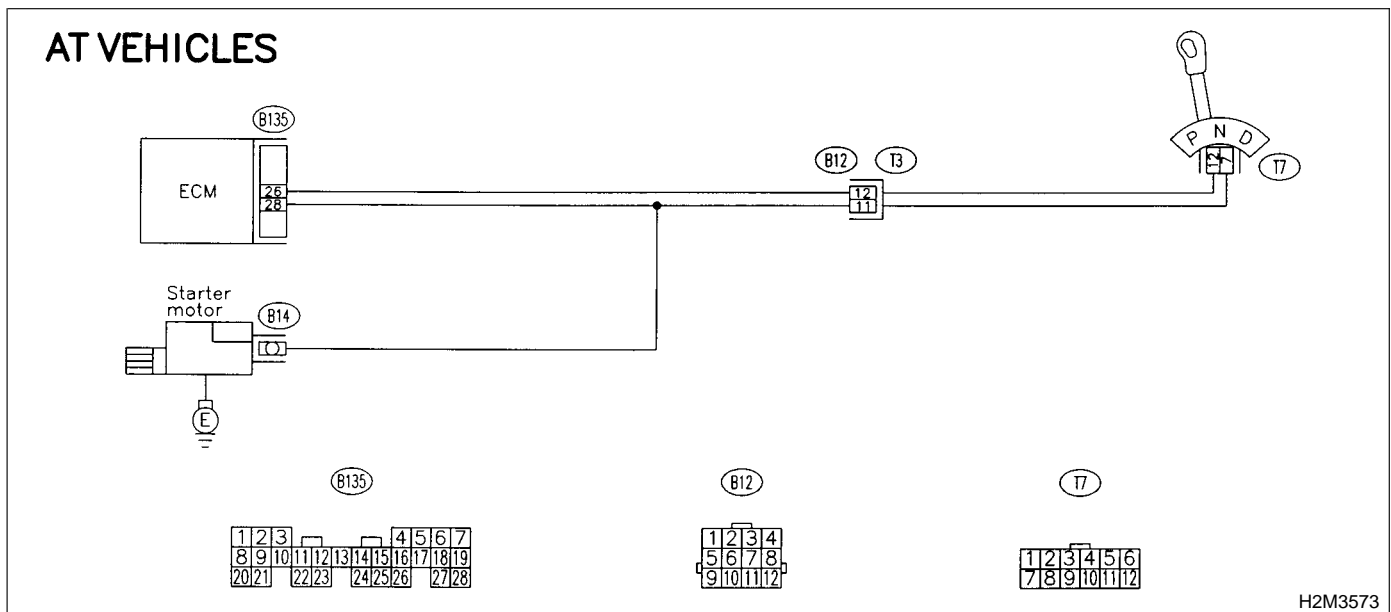
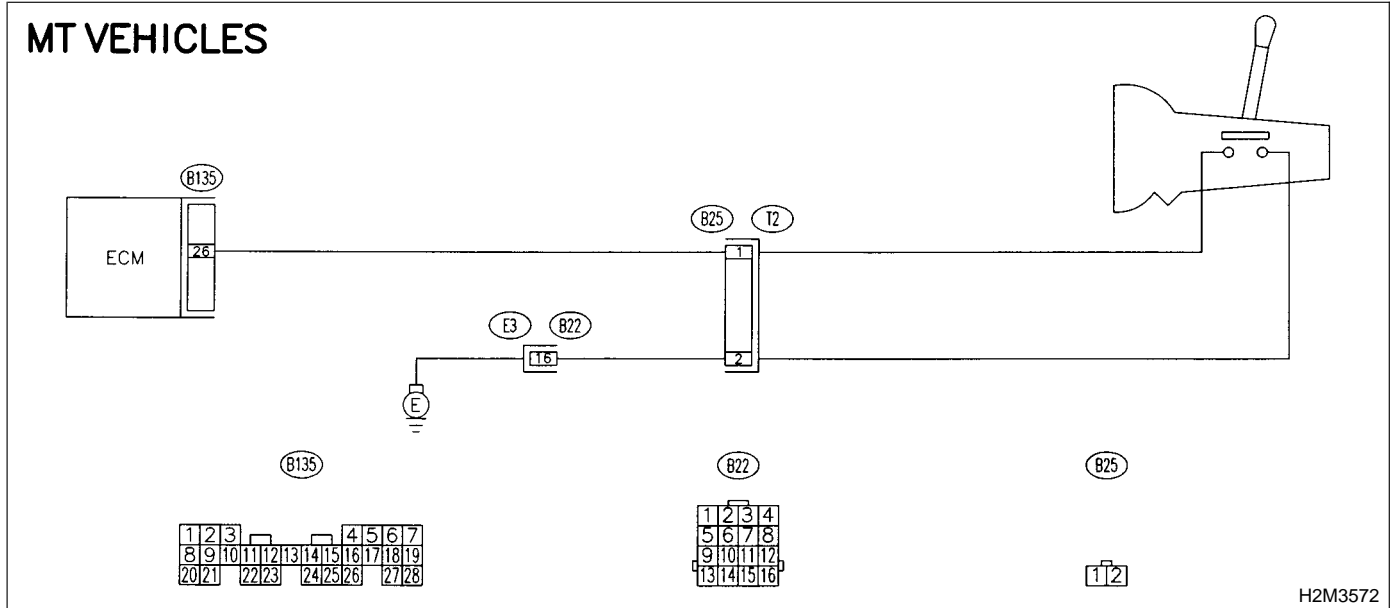

**10BV1 : CHECK TRANSMISSION TYPE.**

- CHECK** : *Is transmission type MT?*
- YES** : Go to step **10BV2**.
- NO** : Go to step **10BV9**.

**10BV2 : CHECK INPUT SIGNAL FOR ECM.**

- 1) Turn ignition switch to ON.
- 2) Measure voltage between ECM and chassis ground.

**Connector & terminal**  
**(B135) No. 26 (+) — Chassis ground (-):**

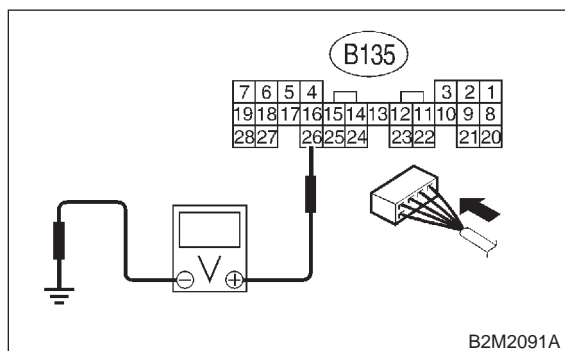

- CHECK** : *Is the voltage more than 10 V in neutral position?*
- YES** : Go to step **10BV3**.
- NO** : Go to step **10BV5**.

**10BV3 : CHECK INPUT SIGNAL FOR ECM.**

Measure voltage between ECM and chassis ground.

**Connector & terminal**  
**(B135) No. 26 (+) — Chassis ground (-):**

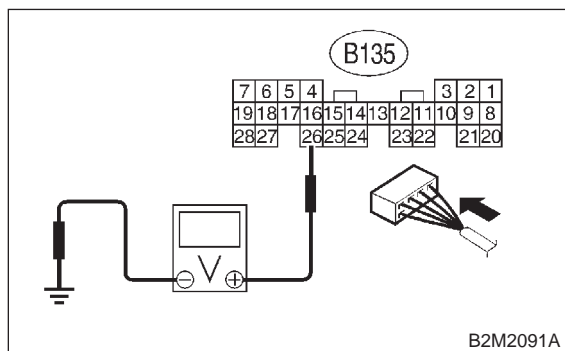

- CHECK** : *Is the voltage less than 1 V in other positions?*
- YES** : Go to step **10BV4**.
- NO** : Go to step **10BV6**.

**10BV4 : CHECK POOR CONTACT.**

Check poor contact in ECM connector. <Ref. to FOREWORD [T3C1].>

- CHECK** : *Is there poor contact in ECM connector?*
- YES** : Repair poor contact in ECM connector.
- NO** : Contact with SOA service.

**NOTE:**  
 Inspection by DTM is required, because probable cause is deterioration of multiple parts.

**10BV5 : CHECK NEUTRAL POSITION SWITCH.**

Measure resistance between transmission harness connector terminals.

**Connector & terminal**  
**(T2) No. 1 — No. 2:**

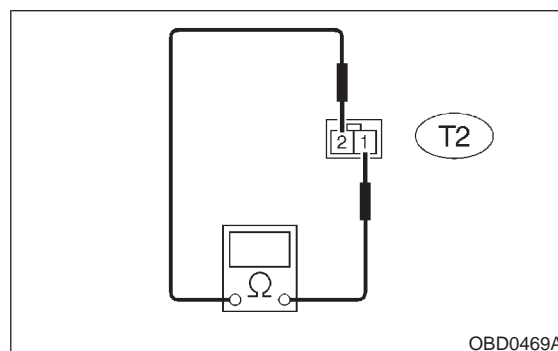

- CHECK** : *Is the resistance less than 1 Ω in other positions?*
- YES** : Go to step **10BV6**.
- NO** : Repair open circuit in transmission harness or replace neutral position switch.

**10BV6 : CHECK HARNESS BETWEEN ECM AND NEUTRAL POSITION SWITCH CONNECTOR.**

- 1) Disconnect connector from ECM.
- 2) Measure resistance of harness between ECM and transmission harness connector.

**Connector & terminal**

**(B135) No. 26 — (B25) No. 1:**

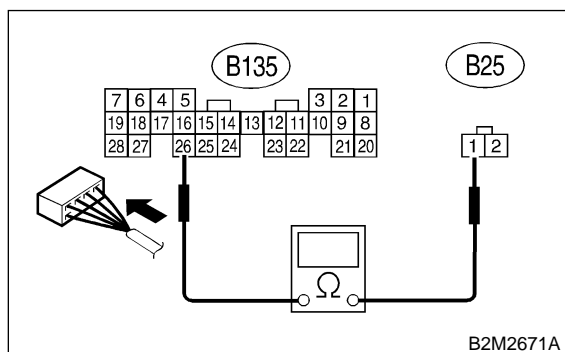

- CHECK** : **Is the resistance less than 1 Ω?**
- YES** : Go to step **10BV7**.
- NO** : Repair open circuit in harness between ECM and transmission harness connector.

**10BV7 : CHECK HARNESS BETWEEN ECM AND NEUTRAL POSITION SWITCH CONNECTOR.**

Measure resistance of harness between transmission harness connector and engine ground.

**Connector & terminal**

**(B25) No. 2 — Engine ground:**

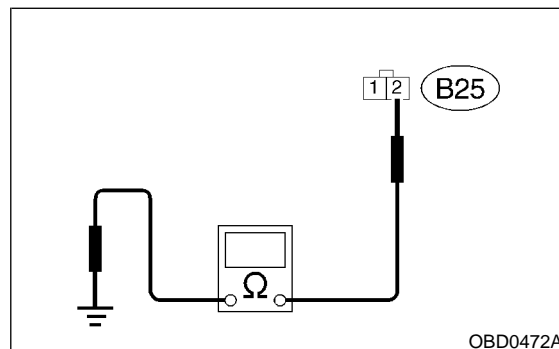

- CHECK** : **Is the resistance less than 5 Ω?**
- YES** : Go to step **10BV8**.
- NO** : Repair harness and connector.

**NOTE:**

In this case, repair the following:

- Open circuit in harness between transmission harness connector and engine grounding terminal
- Poor contact in coupling connector (B22)

**10BV8 : CHECK POOR CONTACT.**

Check poor contact in transmission harness connector. <Ref. to FOREWORD [T3C1].>

- CHECK** : **Is there poor contact in transmission harness connector?**
- YES** : Repair poor contact in transmission harness connector.
- NO** : Contact with SOA service.

**NOTE:**

Inspection by DTM is required, because probable cause is deterioration of multiple parts.

**10BV9 : CHECK DTC P0705 ON DISPLAY.**

- CHECK** : **Does the Subaru Select Monitor or OBD-II general scan tool indicate DTC P0705?**
- YES** : Inspect DTC P0705 using "10. Diagnostics Chart with Trouble Code". <Ref. to 2-7 [T10A0].>
- NO** : Go to step **10BV10**.

**10BV10 : CHECK INPUT SIGNAL FOR ECM.**

- 1) Turn ignition switch to ON.
- 2) Measure voltage between ECM and chassis ground.

**Connector & terminal**  
**(B135) No. 26 (+) — Chassis ground (-):**

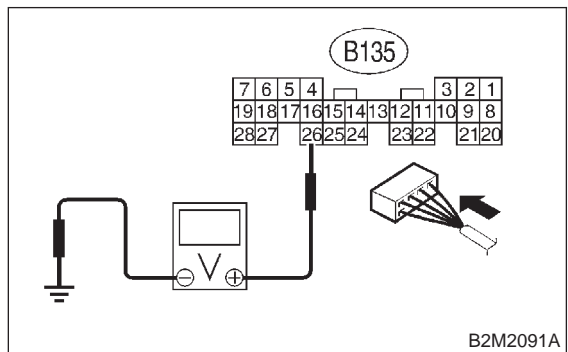

- CHECK** : **Is the voltage between 4.5 and 5.5 V at except "N" and "P" positions?**
- YES** : Even if MIL lights up, the circuit has returned to a normal condition at this time.
- NO** : Go to step **10BV11**.

**10BV11 : CHECK HARNESS BETWEEN ECM AND TRANSMISSION HARNESS CONNECTOR.**

- 1) Turn ignition switch to OFF.
- 2) Disconnect connectors from ECM and transmission harness connector (T3).
- 3) Measure resistance of harness between ECM connector and chassis ground.

**Connector & terminal**  
**(B135) No. 26 — Chassis ground:**

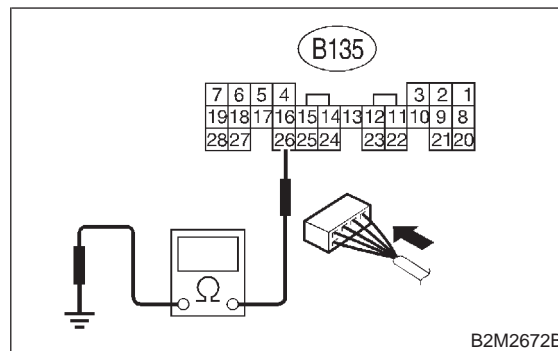

- CHECK** : **Is the resistance less than 10 Ω?**
- YES** : Repair ground short circuit in harness between ECM and transmission harness connector.
- NO** : Go to step **10BV12**.

**10BV12 : CHECK TRANSMISSION HARNESS CONNECTOR.**

- 1) Disconnect connector from inhibitor switch.
- 2) Measure resistance of harness between transmission harness connector and engine ground.

**Connector & terminal**

**(T3) No. 12 — Engine ground:**

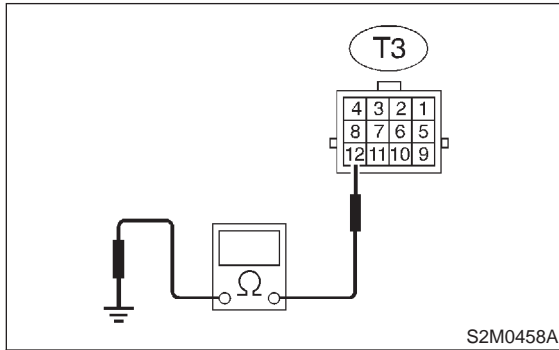

- CHECK** : **Is the resistance less than 10  $\Omega$ ?**
- YES** : Repair ground short circuit in harness between transmission harness and inhibitor switch connector.
- NO** : Go to step **10BV13**.

**10BV13 : CHECK INHIBITOR SWITCH.**

Measure resistance between inhibitor switch connector receptacle's terminals in select lever except for "N" position.

**Terminals**

**No. 7 — No. 12:**

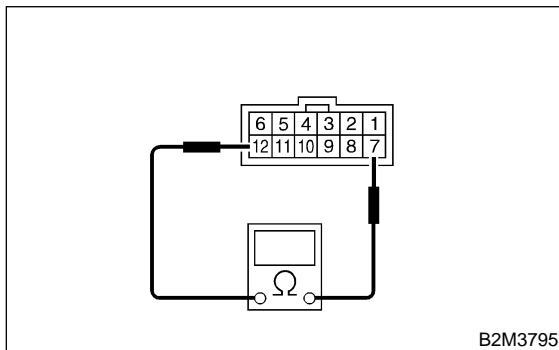

- CHECK** : **Is the resistance more than 1 M $\Omega$  at except "N" and "P" positions?**
- YES** : Go to step **10BV14**.
- NO** : Replace inhibitor switch. <Ref. to 3-2 [W2C0].>

**10BV14 : CHECK SELECTOR CABLE CONNECTION.**

- CHECK** : **Is there any fault in selector cable connection to inhibitor switch?**
- YES** : Repair selector cable connection. <Ref. to 3-2 [W2A0].>
- NO** : Contact with SOA service.

**NOTE:**

Inspection by DTM is required, because probable cause is deterioration of multiple parts.

**MEMO:**



**BW: DTC P1130 — FRONT OXYGEN (A/F) SENSOR CIRCUIT MALFUNCTION (OPEN CIRCUIT) —**

● **DTC DETECTING CONDITION:**

- Two consecutive driving cycles with fault

**CAUTION:**

After repair or replacement of faulty parts, conduct CLEAR MEMORY MODE <Ref. to 2-7 [T3D0].> and INSPECTION MODE <Ref. to 2-7 [T3E0].>.

● **WIRING DIAGRAM:**

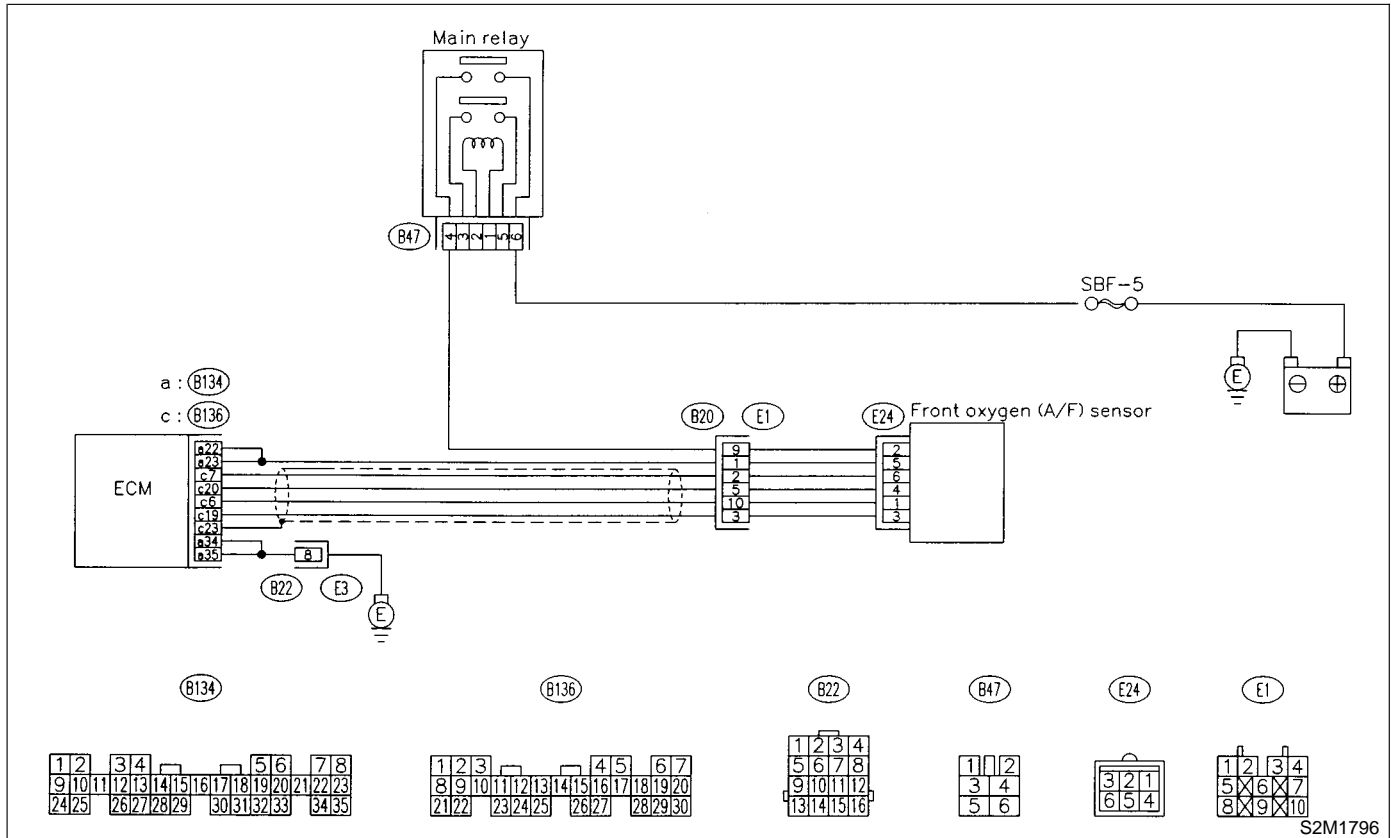

S2M1796

**10BW1 : CHECK HARNESS BETWEEN ECM AND FRONT OXYGEN (A/F) SENSOR CONNECTOR.**

- 1) Turn ignition switch to OFF.
- 2) Disconnect connectors from ECM and front oxygen (A/F) sensor connector.
- 3) Measure resistance of harness between ECM and front oxygen (A/F) sensor connector.

**Connector & terminal**

(B136) No. 6 — (E24) No. 1:

(B136) No. 7 — (E24) No. 6:

(B136) No. 19 — (E24) No. 3:

(B136) No. 20 — (E24) No. 4:

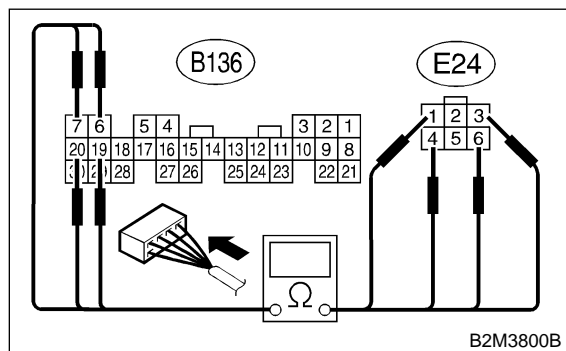

**CHECK** : **Is the resistance less than 1  $\Omega$ ?**

**YES** : Go to step **10BW2**.

**NO** : Repair harness and connector.

**NOTE:**

In this case, repair the following:

- Open circuit in harness between ECM and front oxygen (A/F) sensor connector
- Poor contact in front oxygen (A/F) sensor connector
- Poor contact in ECM connector

**10BW2 : CHECK POOR CONTACT.**

Check poor contact in front oxygen (A/F) sensor connector. <Ref. to FOREWORD [T3C1].>

**CHECK** : **Is there poor contact in front oxygen (A/F) sensor connector?**

**YES** : Repair poor contact in front oxygen (A/F) sensor connector.

**NO** : Replace front oxygen (A/F) sensor. <Ref. to 2-7 [W8A0].>

**BX: DTC P1131 — FRONT OXYGEN (A/F) SENSOR CIRCUIT MALFUNCTION (SHORT CIRCUIT) —**

- **DTC DETECTING CONDITION:**
  - Two consecutive driving cycles with fault

**CAUTION:**

After repair or replacement of faulty parts, conduct CLEAR MEMORY MODE <Ref. to 2-7 [T3D0].> and INSPECTION MODE <Ref. to 2-7 [T3E0].>.

● **WIRING DIAGRAM:**

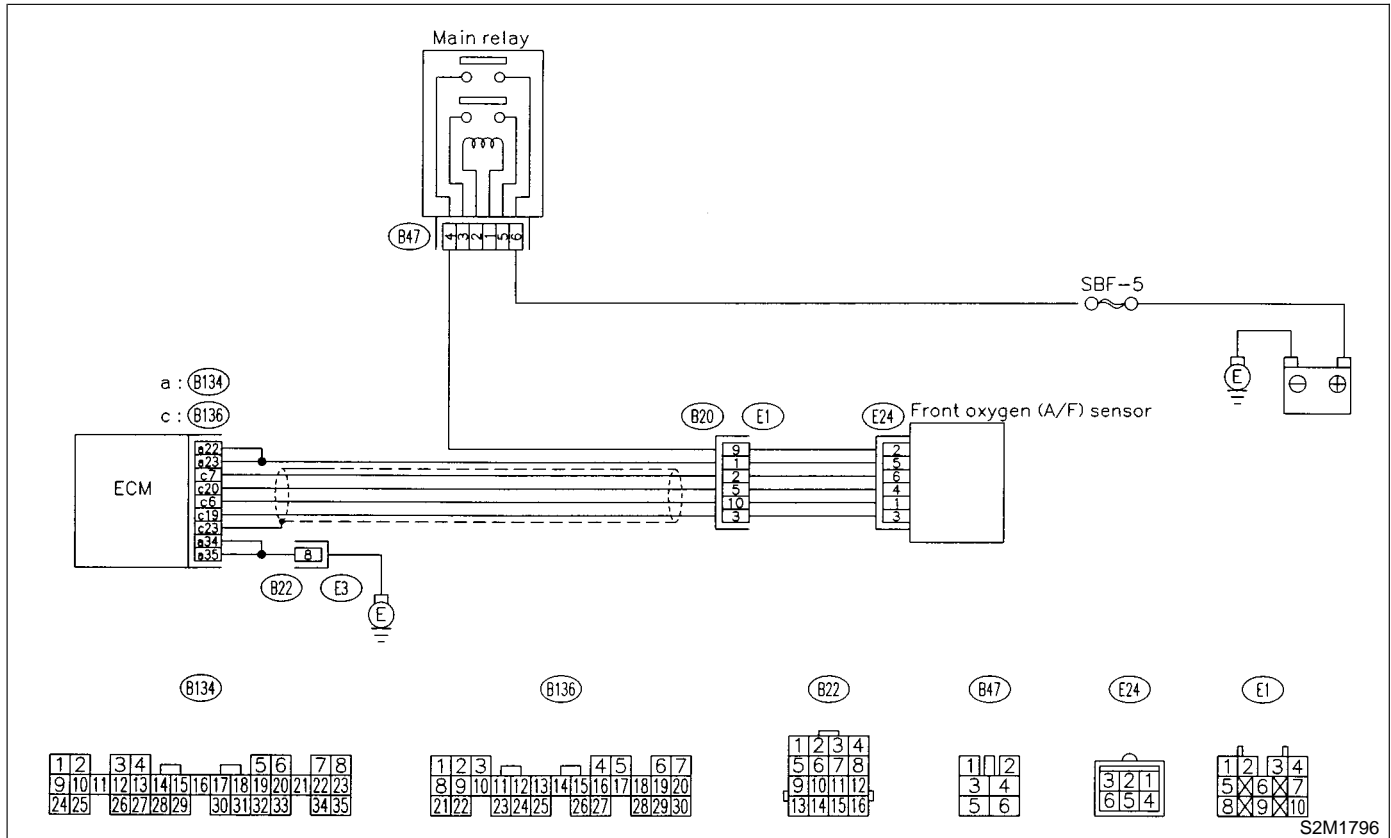

**10BX1 : CHECK HARNESS BETWEEN ECM AND FRONT OXYGEN (A/F) SENSOR CONNECTOR.**

- 1) Turn ignition switch to OFF.
- 2) Disconnect connector from ECM.
- 3) Measure resistance of harness between ECM connector and chassis ground.

**Connector & terminal**

**(B136) No. 6 — Chassis ground:**

**(B136) No. 7 — Chassis ground:**

**(B136) No. 19 — Chassis ground:**

**(B136) No. 20 — Chassis ground:**

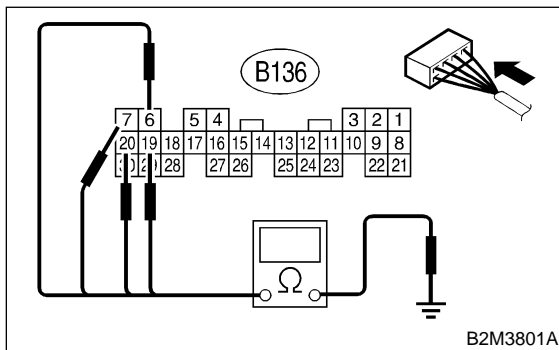

- CHECK** : **Is the resistance more than 10 Ω?**
- YES** : Replace front oxygen (A/F) sensor.  
<Ref. to 2-7 [W8A0].>
- NO** : Repair ground short circuit in harness between ECM and front oxygen (A/F) sensor connector.

**BY: DTC P1132 — FRONT OXYGEN (A/F) SENSOR HEATER CIRCUIT LOW INPUT —**

**• DTC DETECTING CONDITION:**

- Two consecutive driving cycles with fault

**CAUTION:**

After repair or replacement of faulty parts, conduct CLEAR MEMORY MODE <Ref. to 2-7 [T3D0].> and INSPECTION MODE <Ref. to 2-7 [T3E0].>.

**• WIRING DIAGRAM:**

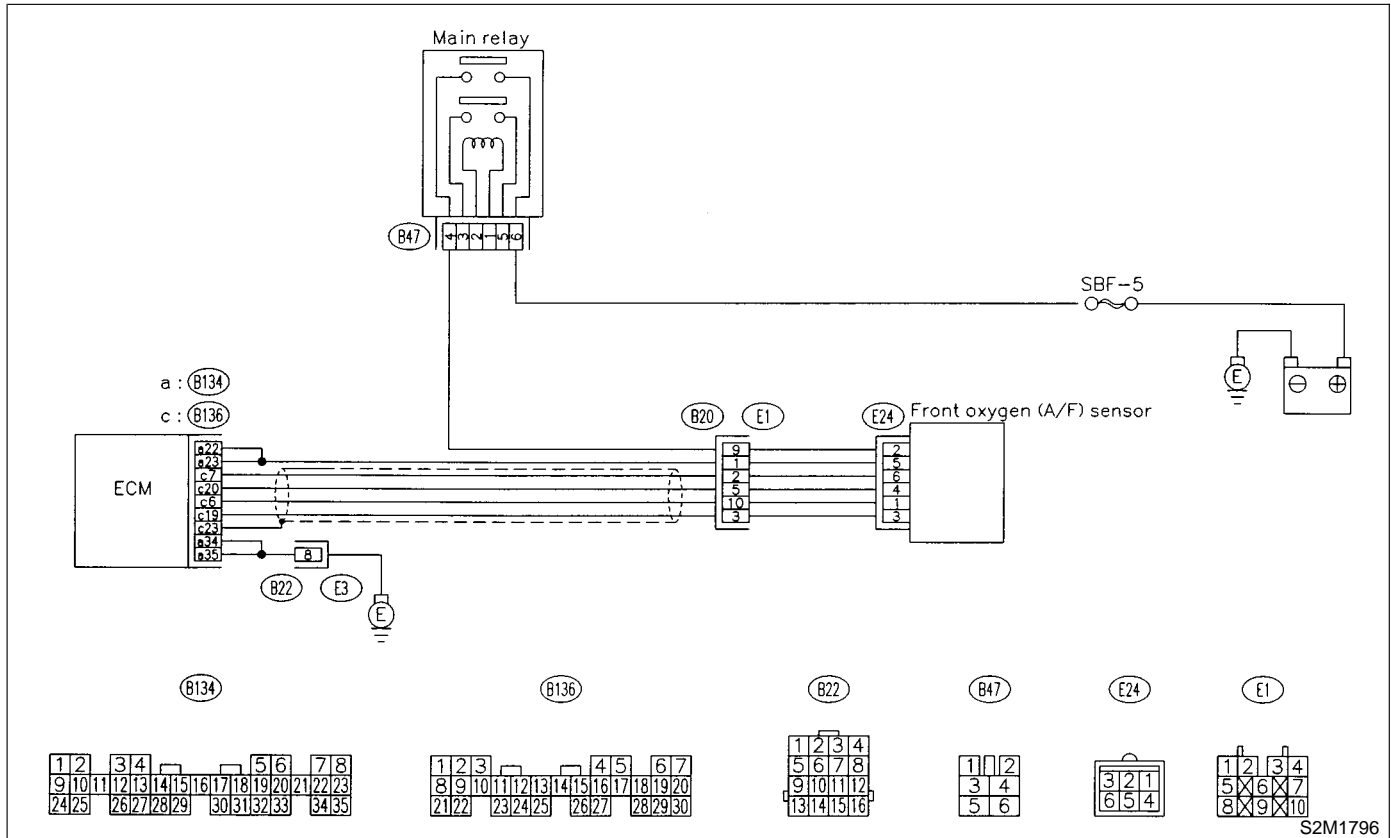

S2M1796

**10BY1 : CHECK ANY OTHER DTC ON DISPLAY.**

- CHECK** : Does the Subaru Select Monitor or OBD-II general scan tool indicate DTC P1132 and P0141 at the same time?
- YES** : Go to step 10BY2.
- NO** : Go to step 10BY6.

**10BY2 : CHECK MAIN RELAY.**

- 1) Turn the ignition switch to OFF.
- 2) Remove main relay.
- 3) Connect battery to main relay terminals No. 1 and No. 2.
- 4) Measure resistance between main relay terminals.

**Terminals**

**No. 4 — No. 6:**

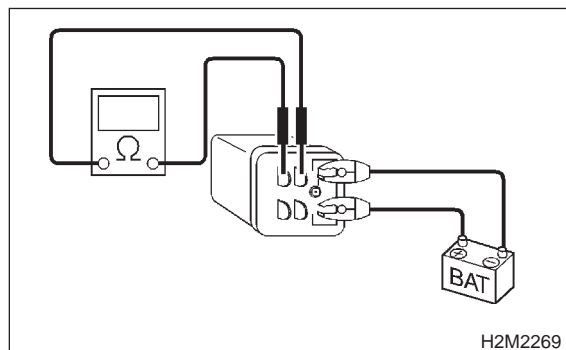

- CHECK** : *Is the resistance less than 10 Ω?*
- YES** : Go to step 10BY3.
- NO** : Replace main relay.

**10BY3 : CHECK POWER SUPPLY TO FRONT OXYGEN (A/F) SENSOR.**

- 1) Turn ignition switch to OFF.
- 2) Disconnect connector from front oxygen (A/F) sensor.
- 3) Turn ignition switch to ON.
- 4) Measure voltage between front oxygen (A/F) sensor connector and engine ground.

**Connector & terminal**

**(E24) No. 2 (+) — Engine ground (-):**

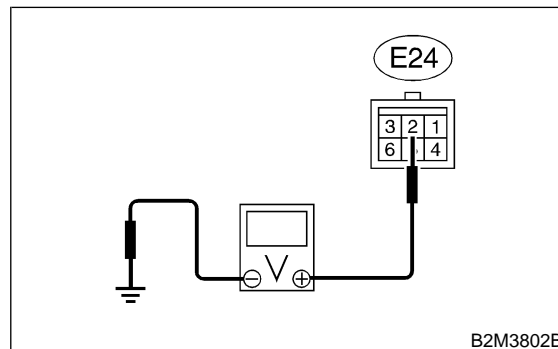

- CHECK** : *Is the voltage more than 10 V?*
- YES** : Go to step 10BY4.
- NO** : Repair power supply line.

**NOTE:**

In this case, repair the following:

- Open circuit in harness between battery and front oxygen (A/F) sensor connector
- Poor contact in front oxygen (A/F) sensor connector
- Poor contact in main relay connector

**10BY4 : CHECK GROUND CIRCUIT OF ECM.**

Measure resistance of harness between ECM connector and chassis ground.

**Connector & terminal**

**(B134) No. 35 — Chassis ground:**

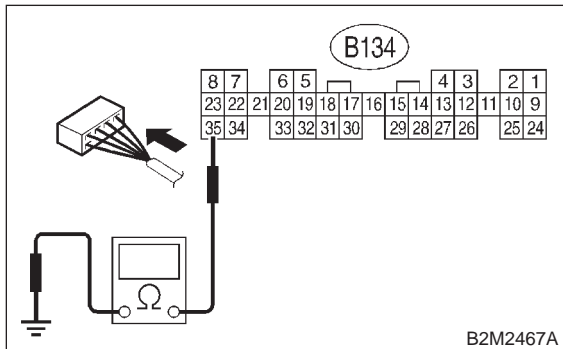

**CHECK** : **Is the resistance less than 5 Ω?**

**YES** : Go to step **10BY5**.

**NO** : Repair harness and connector.

**NOTE:**

In this case, repair the following:

- Open circuit in harness between ECM and engine ground terminal
- Poor contact in ECM connector
- Poor contact in coupling connector (B22)

**10BY5 : CHECK GROUND CIRCUIT OF ECM.**

1) Measure resistance of harness between ECM connector and chassis ground.

**Connector & terminal**

**(B134) No. 34 — Chassis ground:**

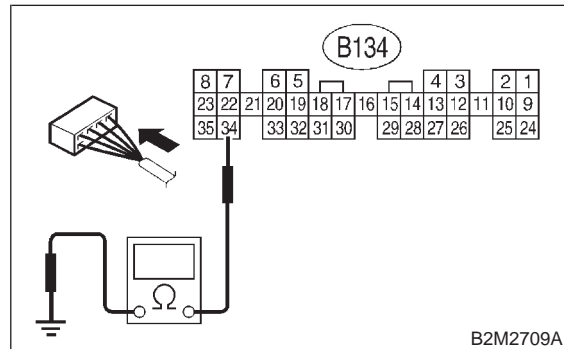

**CHECK** : **Is there resistance less than 5 Ω?**

**YES** : Go to step **10BY6**.

**NO** : Repair harness and connector.

**NOTE:**

In this case, repair the following:

- Open circuit in harness between ECM and engine ground terminal
- Poor contact in ECM connector
- Poor contact in coupling connector (B22)

**10BY6 : CHECK CURRENT DATA.**

- 1) Start the engine.
- 2) Read data of front oxygen (A/F) sensor heater current using Subaru Select Monitor or OBD-II general scan tool.

**NOTE:**

- Subaru Select Monitor

For detailed operation procedure, refer to the "READ CURRENT DATA SHOWN ON DISPLAY FOR ENGINE". <Ref. to 2-7 [T3C4].>

- OBD-II scan tool

For detailed operation procedures, refer to the OBD-II General Scan Tool Instruction Manual.

**CHECK** : **Is the value more than 0.2 A?**

**YES** : Repair poor contact in connector.

**NOTE:**

In this case, repair the following:

- Poor contact in front oxygen (A/F) sensor connector
- Poor contact in ECM connector

**NO** : Go to step **10BY7**.

**10BY7 : CHECK OUTPUT SIGNAL FROM ECM.**

- 1) Start and idle the engine.
- 2) Measure voltage between ECM connector and chassis ground.

**Connector & terminal**  
**(B134) No. 22 (+) — Chassis ground (-):**

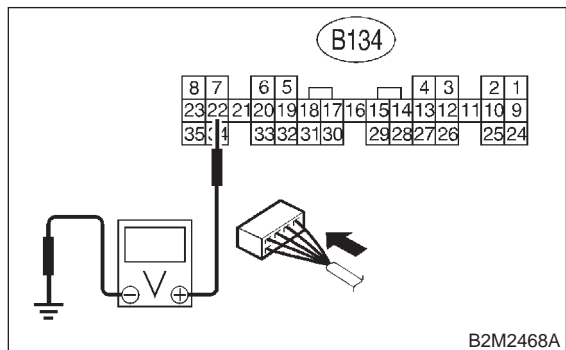

- CHECK** : Is the voltage less than 1.0 V?
- YES** : Go to step 10BY9.
- NO** : Go to step 10BY8.

**10BY8 : CHECK OUTPUT SIGNAL FROM ECM.**

Measure voltage between ECM connector and chassis ground.

**Connector & terminal**  
**(B134) No. 22 (+) — Chassis ground (-):**

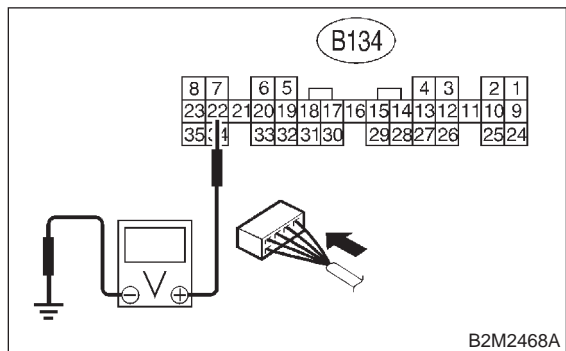

- CHECK** : Does the voltage change less than 1.0 V by shaking harness and connector of ECM while monitoring the value with voltage meter?
- YES** : Repair poor contact in ECM connector.
- NO** : Go to step 10BY9.

**10BY9 : CHECK OUTPUT SIGNAL FROM ECM.**

Measure voltage between ECM connector and chassis ground.

**Connector & terminal**  
**(B134) No. 23 (+) — Chassis ground (-):**

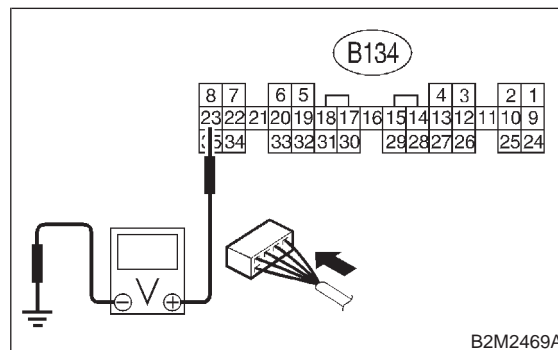

- CHECK** : Is the voltage less than 1.0 V?
- YES** : Go to step 10BY11.
- NO** : Go to step 10BY10.

**10BY10 : CHECK OUTPUT SIGNAL FROM ECM.**

Measure voltage between ECM connector and chassis ground.

**Connector & terminal**  
**(B134) No. 23 (+) — Chassis ground (-):**

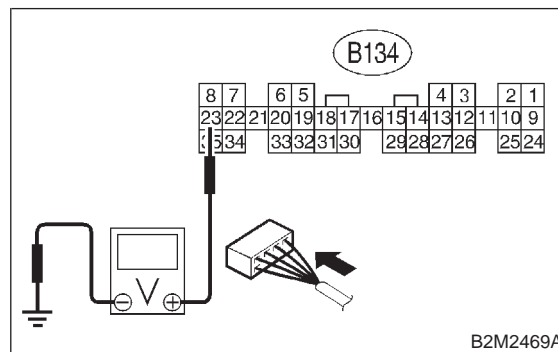

- CHECK** : Does the voltage change less than 1.0 V by shaking harness and connector of ECM while monitoring the value with voltage meter?
- YES** : Repair poor contact in ECM connector.
- NO** : Go to step 10BY11.



**10BY11 : CHECK FRONT OXYGEN (A/F) SENSOR.**

- 1) Turn ignition switch to OFF.
- 2) Measure resistance between front oxygen (A/F) sensor connector terminals.

**Terminals**

**No. 2 — No. 5:**

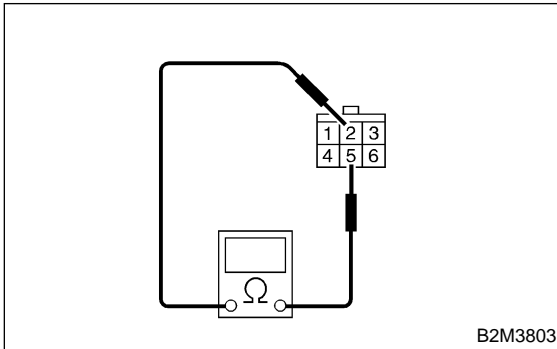

**CHECK** : **Is the resistance less than 10 Ω?**

**YES** : Repair harness and connector.

**NOTE:**

In this case, repair the following:

- Open or ground short circuit in harness between front oxygen (A/F) sensor and ECM connector
- Poor contact in front oxygen (A/F) sensor connector
- Poor contact in ECM connector

**NO** : Replace front oxygen (A/F) sensor.  
<Ref. to 2-7 [W8A0].>

**MEMO:**

**BZ: DTC P1133 — FRONT OXYGEN (A/F) SENSOR HEATER CIRCUIT HIGH INPUT —**

- **DTC DETECTING CONDITION:**
  - Two consecutive driving cycles with fault

**CAUTION:**

After repair or replacement of faulty parts, conduct CLEAR MEMORY MODE <Ref. to 2-7 [T3D0].> and INSPECTION MODE <Ref. to 2-7 [T3E0].>

● **WIRING DIAGRAM:**

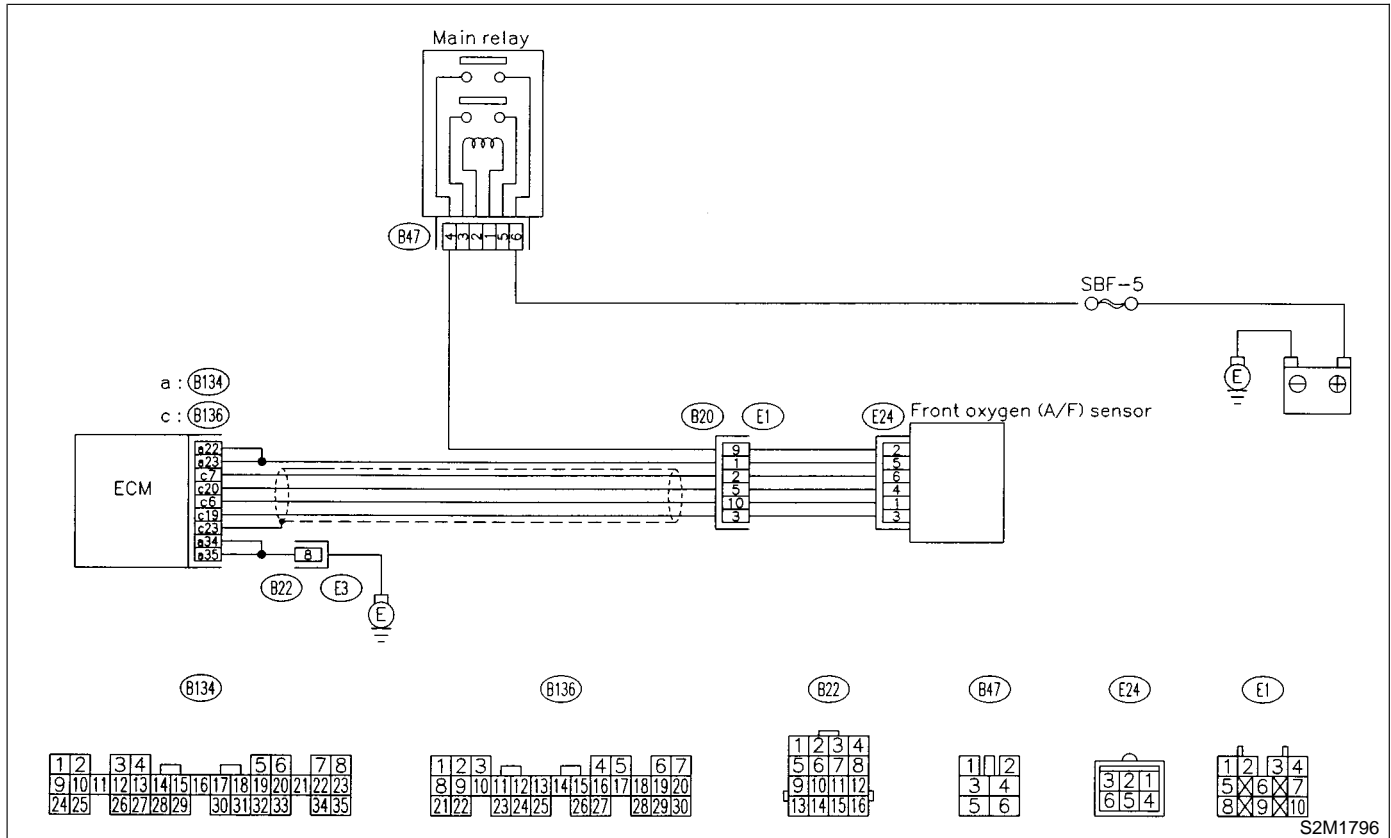

S2M1796

**10BZ1 : CHECK OUTPUT SIGNAL FROM ECM.**

- 1) Turn ignition switch to ON.
- 2) Measure voltage between ECM connector and chassis ground.

**Connector & terminal**

**(B134) No. 23 (+) — Chassis ground (-):**

**(B134) No. 22 (+) — Chassis ground (-):**

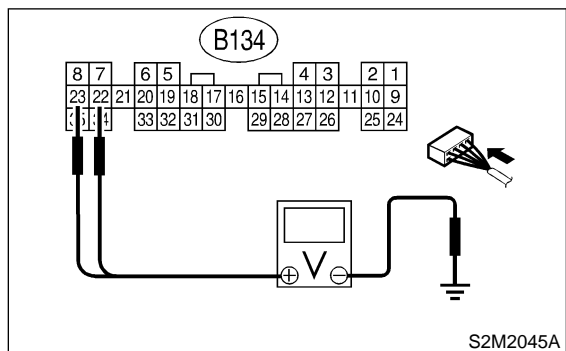

- CHECK** : Is the voltage more than 8 V?
- YES** : Go to step **10BZ3**.
- NO** : Go to step **10BZ2**.

**10BZ2 : CHECK FRONT OXYGEN (A/F) SENSOR HEATER CURRENT.**

- 1) Turn ignition switch to OFF.
- 2) Repair battery short circuit in harness between ECM and front oxygen (A/F) sensor connector.
- 3) Turn ignition switch to ON.
- 4) Read data of front oxygen (A/F) sensor heater current using Subaru Select Monitor or the OBD-II general scan tool.

**NOTE:**

- Subaru Select Monitor  
For detailed operation procedure, refer to the "READ CURRENT DATA SHOWN ON DISPLAY FOR ENGINE". <Ref. to 2-7 [T3C4].>
- OBD-II general scan tool  
For detailed operation procedure, refer to the OBD-II General Scan Tool Instruction Manual.

- CHECK** : Is the value more than 2.3 A?
- YES** : Replace ECM. <Ref. to 2-7 [W17A0].>
- NO** : END

**10BZ3 : CHECK OUTPUT SIGNAL FROM ECM.**

Measure voltage between ECM connector and chassis ground.

**Connector & terminal**

**(B134) No. 23 (+) — Chassis ground (-):**

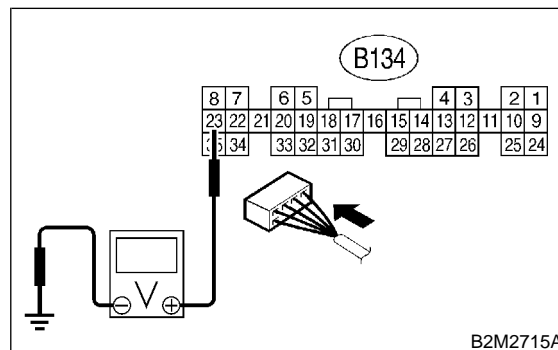

- CHECK** : Does the voltage change more than 8 V by shaking harness and connector of ECM while monitoring the value with voltage meter?
- YES** : Repair battery short circuit in harness between ECM and front oxygen (A/F) sensor connector.
- NO** : Go to step **10BZ4**.

<b>10BZ4 : CHECK OUTPUT SIGNAL FROM ECM.</b>
--

Measure voltage between ECM connector and chassis ground.

**Connector & terminal**

**(B134) No. 22 (+) — Chassis ground (-):**

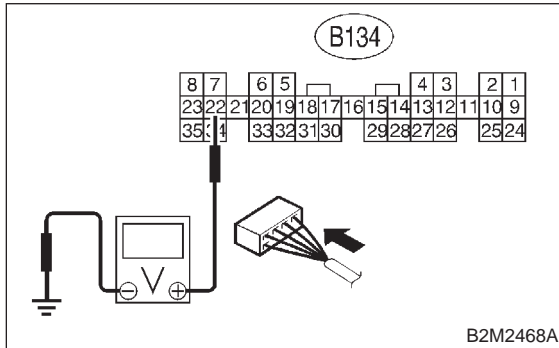

- CHECK** : **Does the voltage change more than 8 V by shaking harness and connector of ECM while monitoring the value with voltage meter?**
- YES** : Repair battery short circuit in harness between ECM and front oxygen (A/F) sensor connector.
- NO** : END

**CA: DTC P1142 — THROTTLE POSITION SENSOR CIRCUIT RANGE/PERFORMANCE PROBLEM (LOW INPUT) —**

- **DTC DETECTING CONDITION:**
  - Two consecutive driving cycles with fault
- **TROUBLE SYMPTOM:**
  - Erroneous idling
  - Engine stalls.
  - Poor driving performance

**CAUTION:**

After repair or replacement of faulty parts, conduct CLEAR MEMORY MODE <Ref. to 2-7 [T3D0].> and INSPECTION MODE <Ref. to 2-7 [T3E0].>

● **WIRING DIAGRAM:**

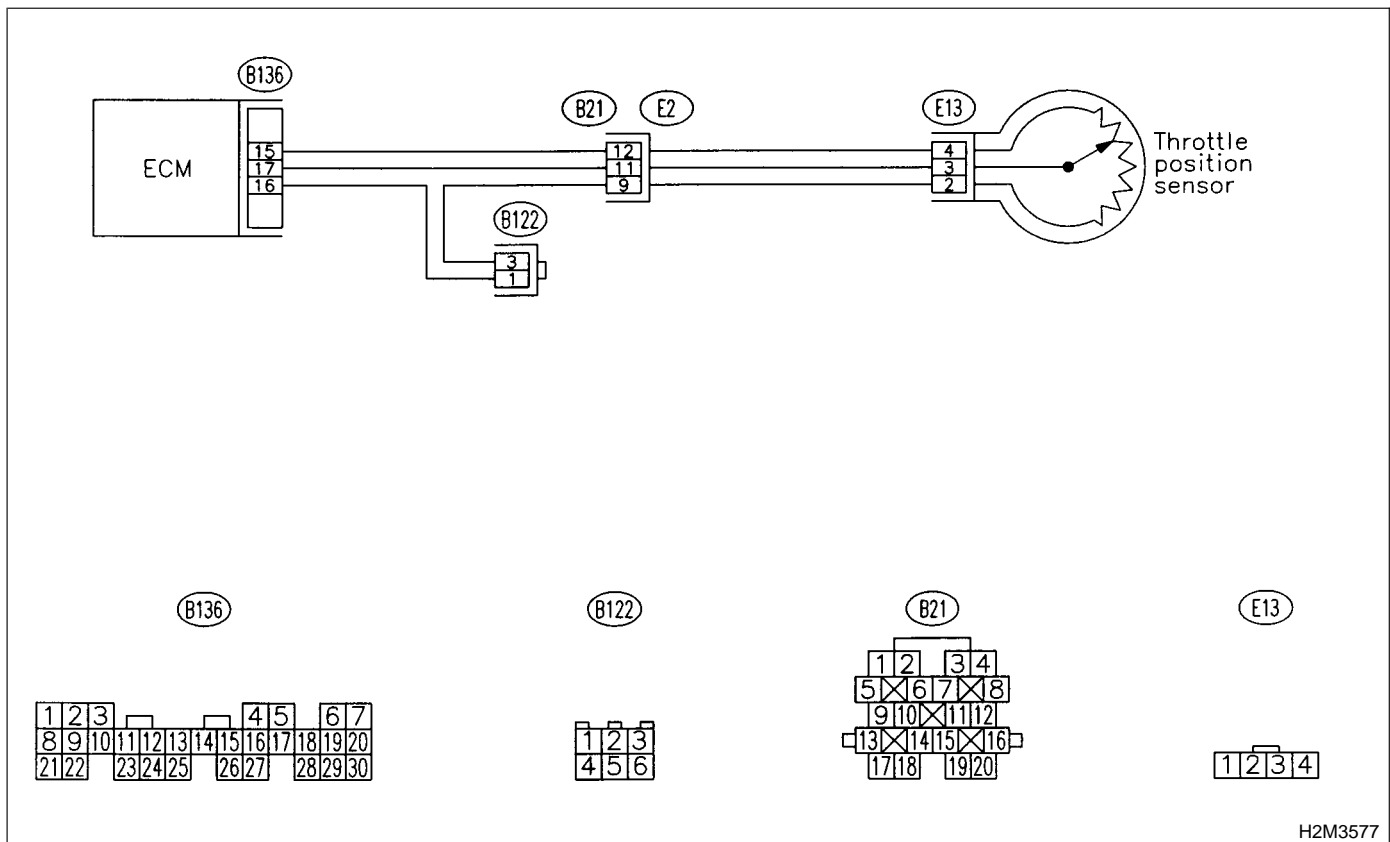

**10CA1 : CHECK ANY OTHER DTC ON DISPLAY.**

- CHECK** : Does the Subaru Select Monitor or OBD-II general scan tool indicate DTC P0122 or P0123?
- YES** : Inspect DTC P0122 or P0123 using "10. Diagnostics Chart with Trouble Code". <Ref. to 2-7 [T10A0].>

**NOTE:**

In this case, it is not necessary to inspect DTC P1142.

- NO** : Replace throttle position sensor. <Ref. to 2-7 [W10A0].>

**CB: DTC P1151 — REAR OXYGEN SENSOR HEATER CIRCUIT HIGH INPUT**

**DTC DETECTING CONDITION:**

- Two consecutive driving cycles with fault

**CAUTION:**

After repair or replacement of faulty parts, conduct CLEAR MEMORY MODE <Ref. to 2-7 [T3D0].> and INSPECTION MODE <Ref. to 2-7 [T3E0].>

**WIRING DIAGRAM:**

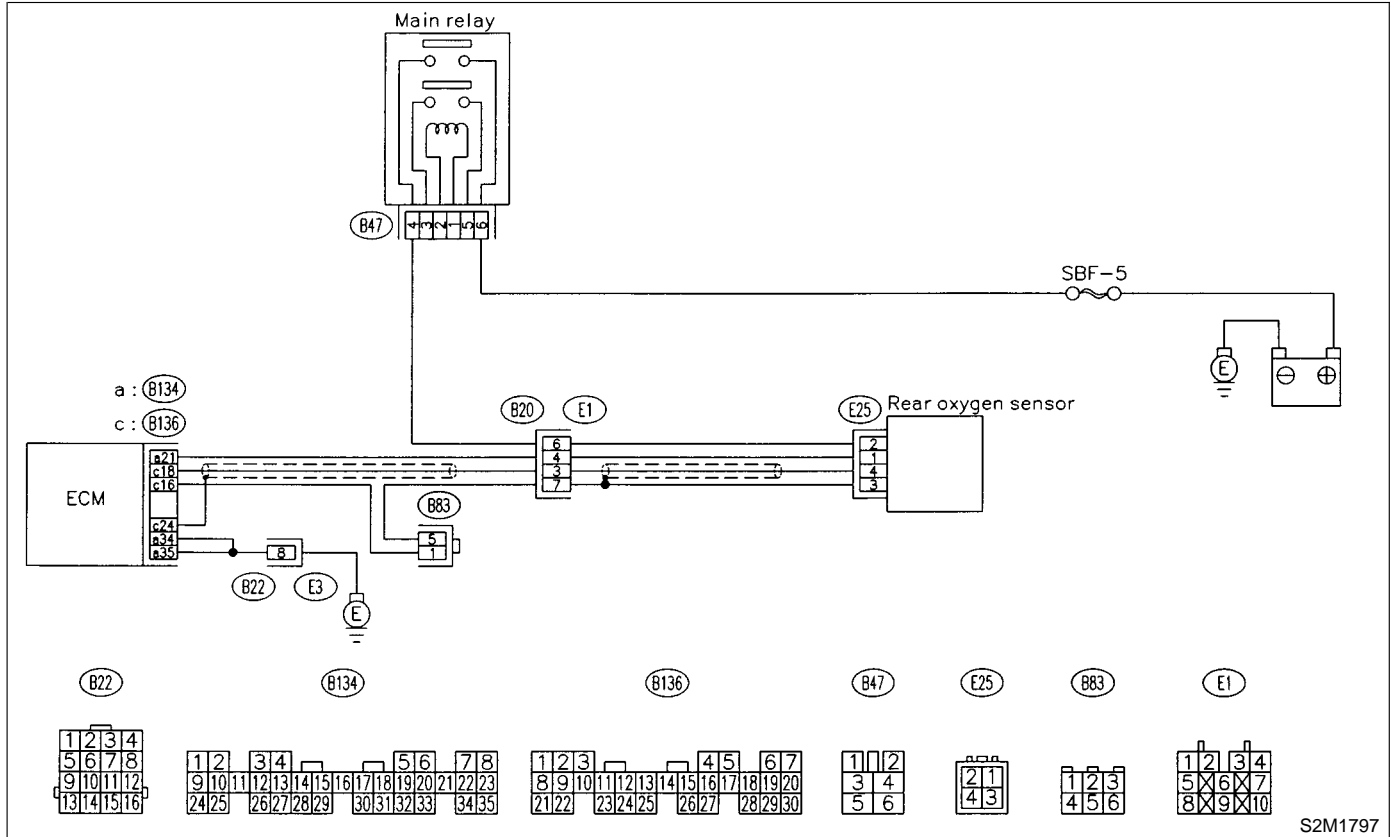

S2M1797

**10CB1 : CHECK INPUT SIGNAL FOR ECM.**

Measure voltage between ECM connector and chassis ground.

**Connector & terminal**

**(B134) No. 21 (+) — Chassis ground (-):**

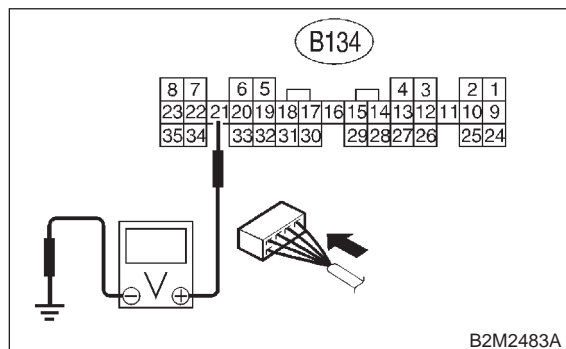

**CHECK** : **Is the voltage more than 8 V?**

**YES** : Go to step **10CB2**.

**NO** : Go to step **10CB3**.

**10CB2 : CHECK CURRENT DATA.**

- 1) Turn ignition switch to OFF.
- 2) Repair battery short circuit in harness between ECM and rear oxygen sensor connector.
- 3) Turn ignition switch to ON.
- 4) Read data of rear oxygen sensor heater current using Subaru Select Monitor or the OBD-II general scan tool.

**NOTE:**

- Subaru Select Monitor

For detailed operation procedure, refer to the "READ CURRENT DATA SHOWN ON DISPLAY FOR ENGINE". <Ref. to 2-7 [T3C4].>

- OBD-II general scan tool

For detailed operation procedure, refer to the OBD-II General Scan Tool Instruction Manual.

**CHECK** : **Is the value more than 7 A?**

**YES** : Replace ECM. <Ref. to 2-7 [W17A0].>

**NO** : END

**10CB3 : CHECK POOR CONTACT.**

Check poor contact in ECM connector. <Ref. to FOREWORD [T3C1].>

**CHECK** : **Is there poor contact in ECM connector?**

**YES** : Repair poor contact in ECM connector.

**NO** : END



**CC: DTC P1207 — AIR ASSIST INJECTOR SOLENOID VALVE CIRCUIT LOW INPUT —**

- **DTC DETECTING CONDITION:**
  - Immediately at fault recognition
- **TROUBLE SYMPTOM:**
  - Erroneous idling
  - Engine stalls.

**CAUTION:**

After repair or replacement of faulty parts, conduct CLEAR MEMORY MODE <Ref. to 2-7 [T3D0].> and INSPECTION MODE <Ref. to 2-7 [T3E0].>

● **WIRING DIAGRAM:**

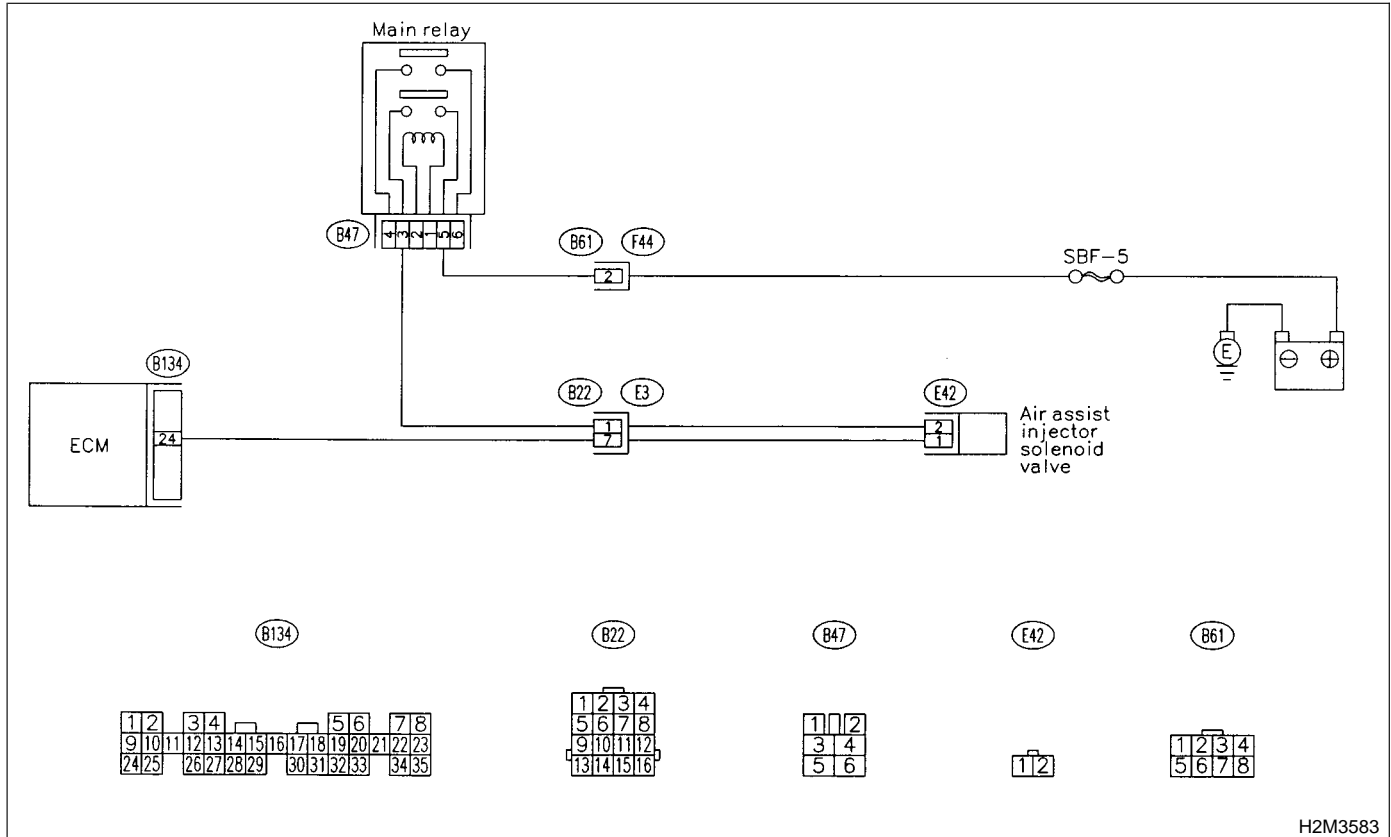

H2M3583

**10CC1 : CHECK OUTPUT SIGNAL FROM ECM.**

- 1) Turn ignition switch to ON.
- 2) Measure voltage between ECM and chassis ground.

**Connector & terminal**

**(B134) No. 24 (+) — Chassis ground (-):**

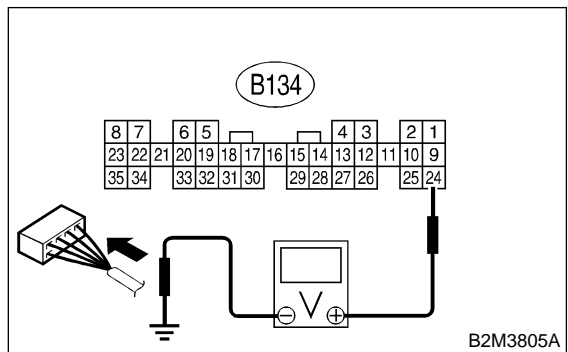

- CHECK** : *Is the voltage more than 10 V?*
- YES** : Repair poor contact in ECM connector.
- NO** : Go to step **10CC2**.

**10CC2 : CHECK MAIN RELAY.**

- 1) Turn the ignition switch to OFF.
- 2) Remove main relay.
- 3) Connect battery to main relay terminals No. 1 and No. 2.
- 4) Measure resistance between main relay terminals.

**Terminals**

**No. 4 — No. 6:**

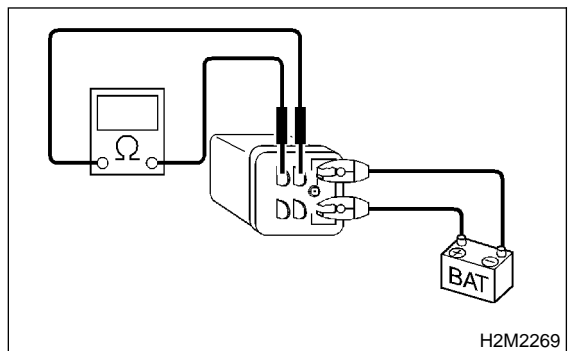

- CHECK** : *Is the resistance less than 10 Ω?*
- YES** : Go to step **10CC3**.
- NO** : Replace main relay.

**10CC3 : CHECK POWER SUPPLY TO AIR ASSIST INJECTOR SOLENOID VALVE.**

- 1) Turn ignition switch to OFF.
- 2) Disconnect connector from air assist injector solenoid valve.
- 3) Turn ignition switch to ON.
- 4) Measure voltage between air assist injector solenoid valve and engine ground.

**Connector & terminal**

**(E42) No. 2 (+) — Engine ground (-):**

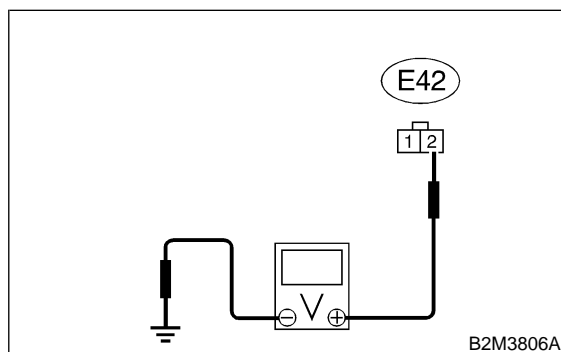

- CHECK** : *Is the voltage more than 10 V?*
- YES** : Go to step **10CC4**.
- NO** : Repair harness and connector.

**NOTE:**

In this case, repair the following:

- Open circuit in harness between battery and air assist injector solenoid valve connector
- Poor contact in coupling connector (B22)

**10CC4 : CHECK HARNESS BETWEEN ECM AND AIR ASSIST INJECTOR SOLENOID VALVE CONNECTOR.**

- 1) Turn ignition switch to OFF.
- 2) Disconnect connector from ECM.
- 3) Measure resistance of harness between ECM and air assist injector solenoid valve connector.

**Connector & terminal**

**(B134) No. 24 — (E42) No. 1:**

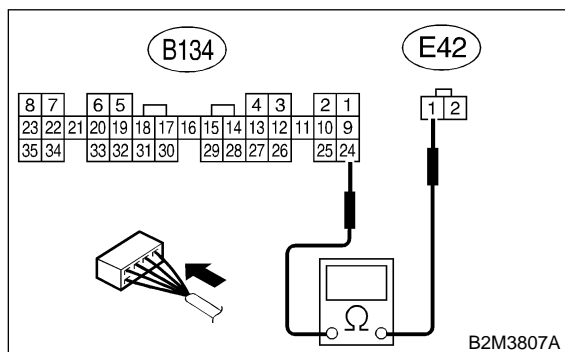

- CHECK** : *Is the resistance less than 1  $\Omega$ ?*
- YES** : Go to step **10CC5**.
- NO** : Repair harness and connector.

**NOTE:**

In this case, repair the following:

- Open circuit in harness between ECM and air assist injector solenoid valve connector
- Poor contact in coupling connector (B22)

**10CC5 : CHECK HARNESS BETWEEN ECM AND AIR ASSIST INJECTOR SOLENOID VALVE CONNECTOR.**

Measure resistance of harness between ECM and chassis ground.

**Connector & terminal**

**(B134) No. 24 — Chassis ground:**

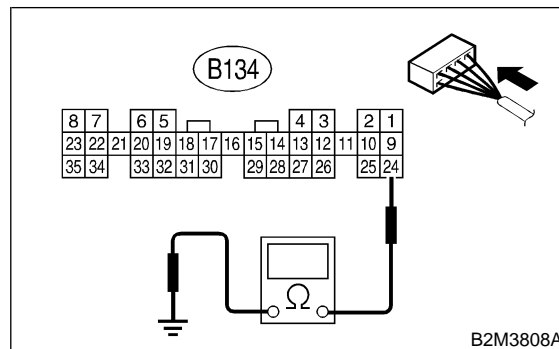

- CHECK** : *Is the resistance less than 10  $\Omega$ ?*
- YES** : Repair ground short circuit in harness between ECM and air assist injector solenoid valve connector.
- NO** : Go to step **10CC6**.

**10CC6 : CHECK POOR CONTACT.**

Check poor contact in ECM and air assist injector solenoid valve connectors. <Ref. to FOREWORD [T3C1].>

- CHECK** : *Is there poor contact in ECM and air assist injector solenoid valve connectors?*
- YES** : Repair poor contact in ECM and air assist injector solenoid valve connectors.
- NO** : Replace air assist injector solenoid valve. <Ref. to 2-7 [W14A0].>

MEMO:

**CD: DTC P1208 — AIR ASSIST INJECTOR SOLENOID VALVE CIRCUIT HIGH INPUT —**

- **DTC DETECTING CONDITION:**
  - Immediately at fault recognition
- **TROUBLE SYMPTOM:**
  - Erroneous idling
  - Engine stalls.

**CAUTION:**

After repair or replacement of faulty parts, conduct CLEAR MEMORY MODE <Ref. to 2-7 [T3D0].> and INSPECTION MODE <Ref. to 2-7 [T3E0].>

● **WIRING DIAGRAM:**

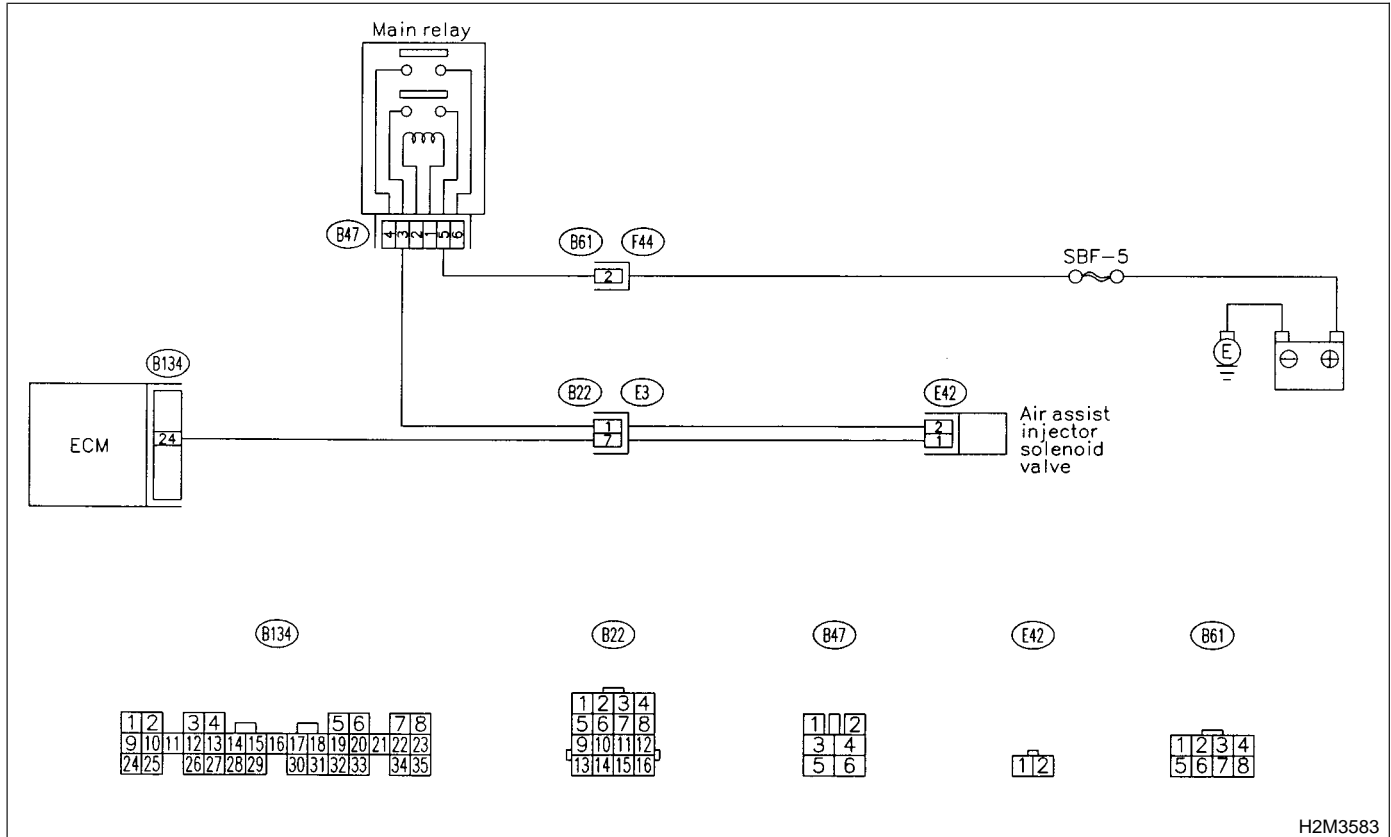

H2M3583

**10CD1 : CHECK OUTPUT SIGNAL FROM ECM.**

- 1) Turn ignition switch to ON.
- 2) Measure voltage between ECM and chassis ground.

**Connector & terminal**

**(B134) No. 24 (+) — Chassis ground (-):**

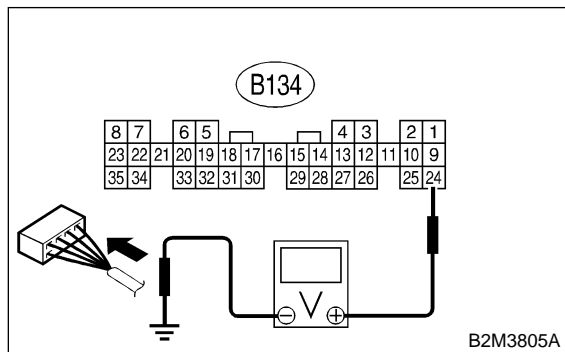

- CHECK** : **Is the voltage more than 10 V?**
- YES** : Go to step **10CD2**.
- NO** : Go to step **10CD3**.

**10CD2 : CHECK OUTPUT SIGNAL FROM ECM.**

- 1) Turn ignition switch to OFF.
- 2) Disconnect connector from air assist injector solenoid valve.
- 3) Turn ignition switch to ON.
- 4) Measure voltage between ECM and chassis ground.

**Connector & terminal**

**(B134) No. 24 (+) — Chassis ground (-):**

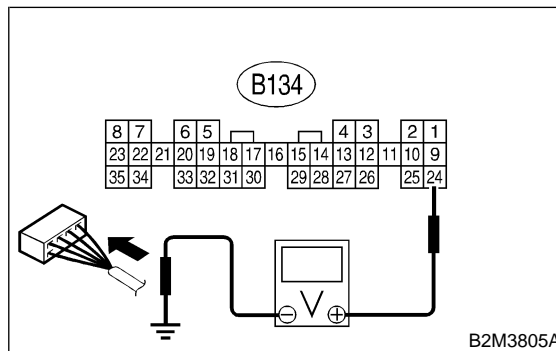

- CHECK** : **Is the voltage more than 10 V?**
- YES** : Repair battery short circuit in harness between ECM and air assist injector solenoid valve connector. After repair, replace ECM. <Ref. to 2-7 [W17A0].>
- NO** : Replace air assist injector solenoid valve <Ref. to 2-7 [W14A0].> and ECM <Ref. to 2-7 [W17A0].>.

**10CD3 : CHECK OUTPUT SIGNAL FROM ECM.**

Measure voltage between ECM and chassis ground.

**Connector & terminal**

**(B134) No. 24 (+) — Chassis ground (-):**

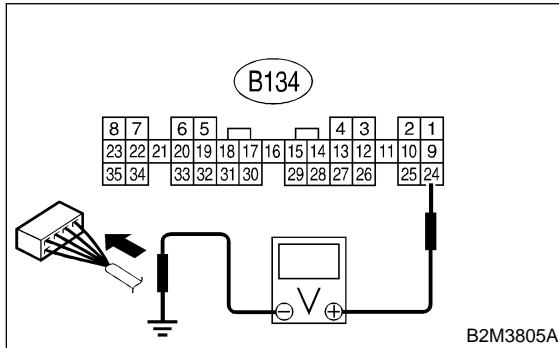

- CHECK** : **Does the voltage change more than 10 V by shaking harness and connector of ECM while monitoring the value with voltage meter?**
- YES** : Repair battery short circuit in harness between ECM and air assist injector solenoid valve connector. After repair, replace ECM. <Ref. to 2-7 [W17A0].>
- NO** : Contact with SOA service.

**NOTE:**

Inspection by DTM is required, because probable cause is deterioration of multiple parts.

**MEMO:**



**CE: DTC P1325 — KNOCK SENSOR CIRCUIT LOW INPUT —**

- **DTC DETECTING CONDITION:**
  - Immediately at fault recognition
- **TROUBLE SYMPTOM:**
  - Poor driving performance
  - Knocking occurs.

**CAUTION:**

After repair or replacement of faulty parts, conduct CLEAR MEMORY MODE <Ref. to 2-7 [T3D0].> and INSPECTION MODE <Ref. to 2-7 [T3E0].>

● **WIRING DIAGRAM:**

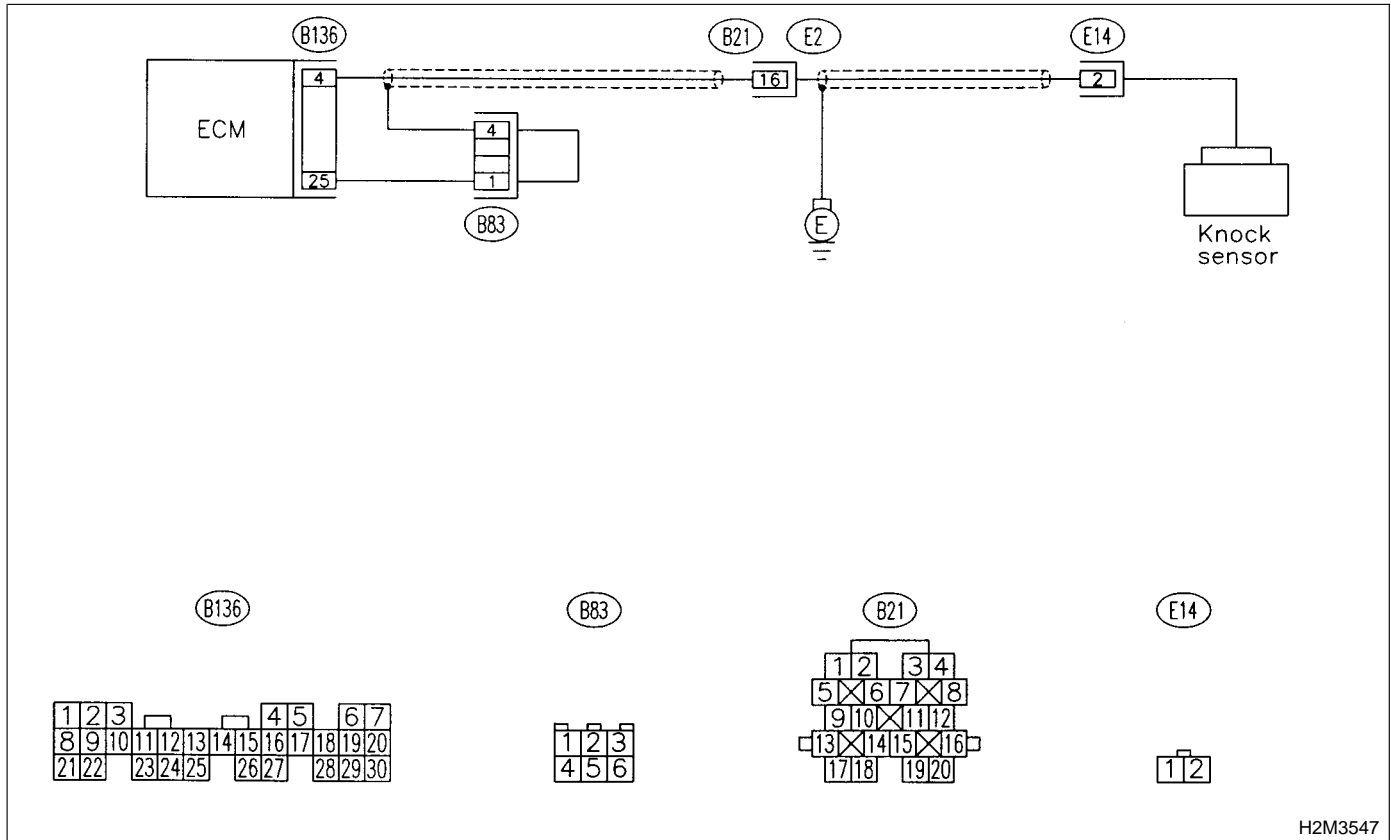

H2M3547

**10CE1 : CHECK HARNESS BETWEEN KNOCK SENSOR AND ECM CONNECTOR.**

- 1) Turn ignition switch to OFF.
- 2) Disconnect connector from ECM.
- 3) Measure resistance between ECM harness connector and chassis ground.

**Connector & terminal**  
**(B136) No. 4 — Chassis ground:**

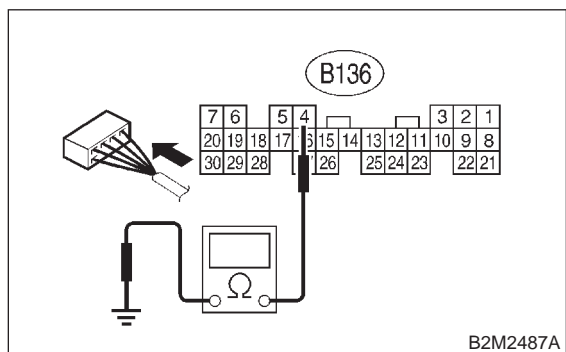

- CHECK** : *Is the resistance more than 700 kΩ?*  
**YES** : Go to step 10CE3.  
**NO** : Go to step 10CE2.

**10CE2 : CHECK HARNESS BETWEEN KNOCK SENSOR AND ECM CONNECTOR.**

Measure resistance of harness between ECM connector and chassis ground.

**Connector & terminal**  
**(B136) No. 4 — Chassis ground:**

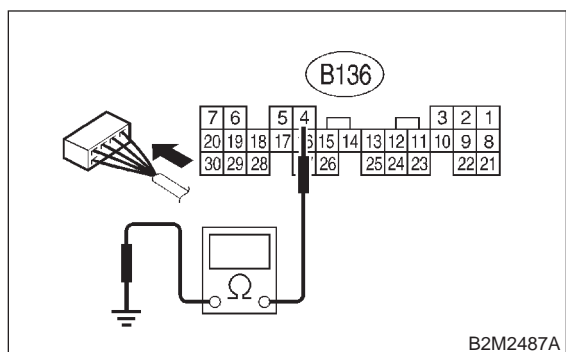

- CHECK** : *Is the resistance less than 400 kΩ?*  
**YES** : Go to step 10CE5.  
**NO** : Go to step 10CE6.

**10CE3 : CHECK KNOCK SENSOR.**

- 1) Disconnect connector from knock sensor.
- 2) Measure resistance between knock sensor connector terminal and engine ground.

**Terminal**  
**No. 2 — Engine ground:**

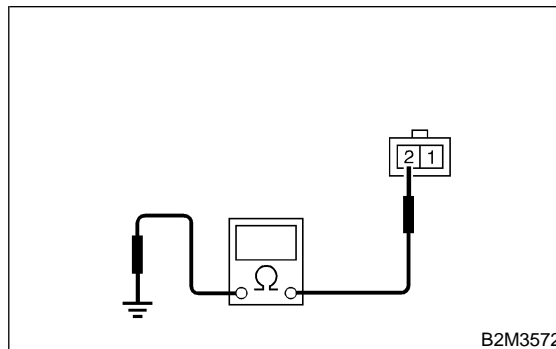

- CHECK** : *Is the resistance more than 700 kΩ?*  
**YES** : Go to step 10CE4.  
**NO** : Repair harness and connector.

**NOTE:**  
In this case, repair the following:

- Open circuit in harness between knock sensor and ECM connector
- Poor contact in knock sensor connector
- Poor contact in coupling connector (B21)

**10CE4 : CHECK CONDITION OF KNOCK SENSOR INSTALLATION.**

- CHECK** : *Is the knock sensor installation bolt tightened securely?*  
**YES** : Replace knock sensor. <Ref. to 2-7 [W7A0].>  
**NO** : Tighten knock sensor installation bolt securely.

**10CE5 : CHECK KNOCK SENSOR.**

- 1) Disconnect connector from knock sensor.
- 2) Measure resistance between knock sensor connector terminal and engine ground.

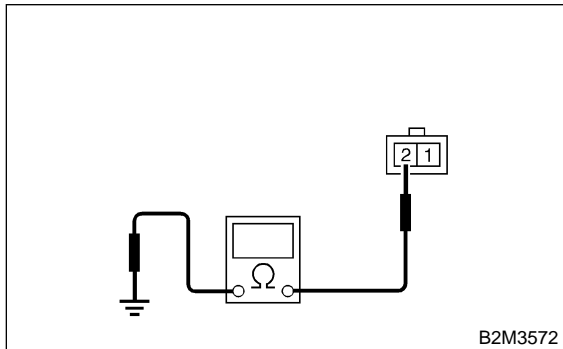
**Terminal****No. 2 — Engine ground:**

- CHECK** : **Is the resistance less than 400 kΩ?**
- YES** : Replace knock sensor. <Ref. to 2-7 [W7A0].>
- NO** : Repair ground short circuit in harness between knock sensor connector and ECM connector.

**NOTE:**

The harness between both connectors is shielded.  
Repair short circuit of harness together with shield.

**10CE6 : CHECK INPUT SIGNAL FOR ECM.**

- 1) Connect connectors to ECM and knock sensor.
- 2) Turn ignition switch to ON.
- 3) Measure voltage between ECM and chassis ground.

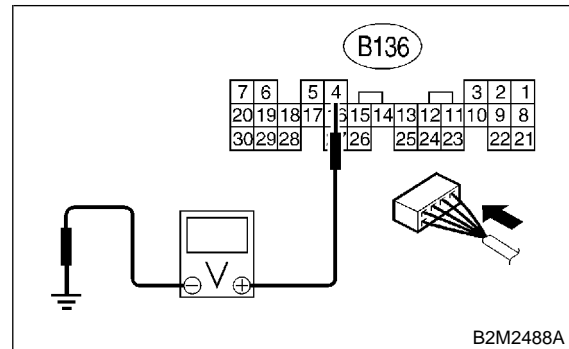
**Connector & terminal****(B136) No. 4 (+) — Chassis ground (-):**

- CHECK** : **Is the voltage more than 2 V?**
- YES** : Even if MIL lights up, the circuit has returned to a normal condition at this time. (However, the possibility of poor contact still remains.)

**NOTE:**

In this case, repair the following:

- Poor contact in knock sensor connector
  - Poor contact in ECM connector
  - Poor contact in coupling connector (B21)
- NO** : Repair poor contact in ECM connector.

**MEMO:**

**CF: DTC P1400 — FUEL TANK PRESSURE CONTROL SOLENOID VALVE CIRCUIT LOW INPUT —**

**• DTC DETECTING CONDITION:**

- Two consecutive driving cycles with fault

**CAUTION:**

After repair or replacement of faulty parts, conduct CLEAR MEMORY MODE <Ref. to 2-7 [T3D0].> and INSPECTION MODE <Ref. to 2-7 [T3E0].>

**• WIRING DIAGRAM:**

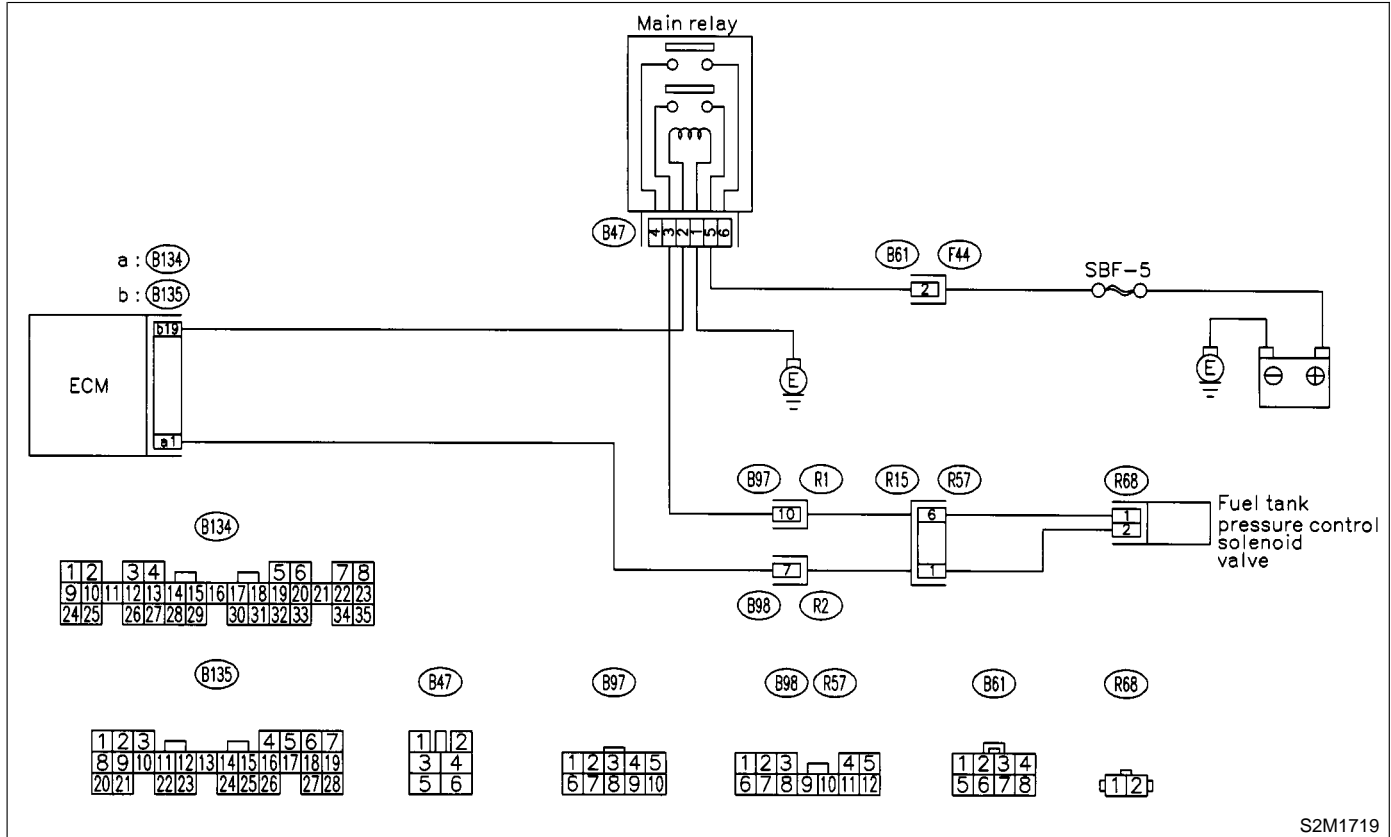

S2M1719

**10CF1 : CHECK OUTPUT SIGNAL FROM ECM.**

- 1) Turn ignition switch to ON.
- 2) Measure voltage between ECM and chassis ground.

**Connector & terminal**

**(B134) No. 1 (+) — Chassis ground (-):**

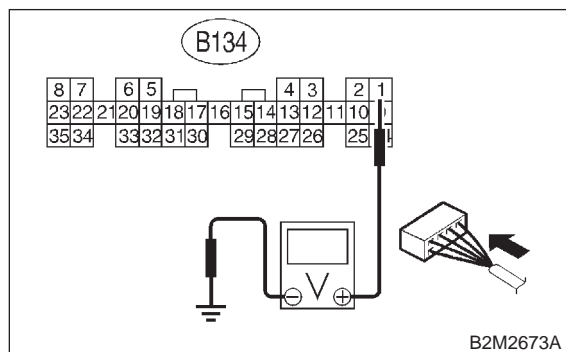

- CHECK** : *Is the voltage more than 10 V?*
- YES** : Go to step **10CF2**.
- NO** : Go to step **10CF3**.

**10CF2 : CHECK POOR CONTACT.**

Check poor contact in ECM connector. <Ref. to FOREWORD [T3C1].>

- CHECK** : *Is there poor contact in ECM connector?*
- YES** : Repair poor contact in ECM connector.
- NO** : Contact with SOA service.

**NOTE:**

Inspection by DTM is required, because probable cause is deterioration of multiple parts.

**10CF3 : CHECK HARNESS BETWEEN FUEL TANK PRESSURE CONTROL SOLENOID VALVE AND ECM CONNECTOR.**

- 1) Turn ignition switch to OFF.
- 2) Disconnect connectors from fuel tank pressure control solenoid valve and ECM.
- 3) Measure resistance of harness between fuel tank pressure control solenoid valve connector and chassis ground.

**Connector & terminal**

**(R68) No. 2 — Chassis ground:**

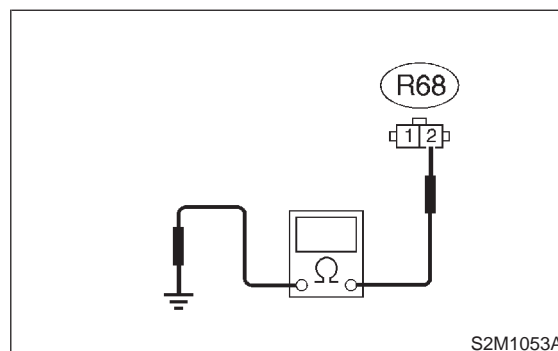

- CHECK** : *Is the resistance less than 10 Ω?*
- YES** : Repair ground short circuit in harness between ECM and fuel tank pressure control solenoid valve connector.
- NO** : Go to step **10CF4**.

**10CF4 : CHECK HARNESS BETWEEN FUEL TANK PRESSURE CONTROL SOLENOID VALVE AND ECM CONNECTOR.**

Measure resistance of harness between ECM and fuel tank pressure control solenoid valve connector.

**Connector & terminal**  
**(B134) No. 1 — (R68) No. 2:**

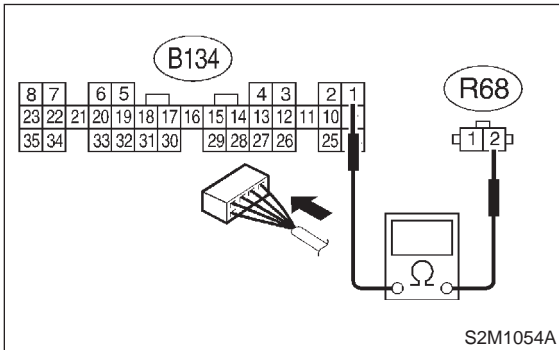

- CHECK** : *Is the voltage less than 1 Ω?*
- YES** : Go to step **10CF5**.
- NO** : Repair harness and connector.

**NOTE:**

In this case, repair the following:

- Open circuit in harness between ECM and fuel tank pressure control solenoid valve connector
- Poor contact in coupling connectors (R57 and B98)

**10CF5 : CHECK FUEL TANK PRESSURE CONTROL SOLENOID VALVE.**

Measure resistance between fuel tank pressure control solenoid valve terminals.

**Terminals**  
**No. 1 — No. 2:**

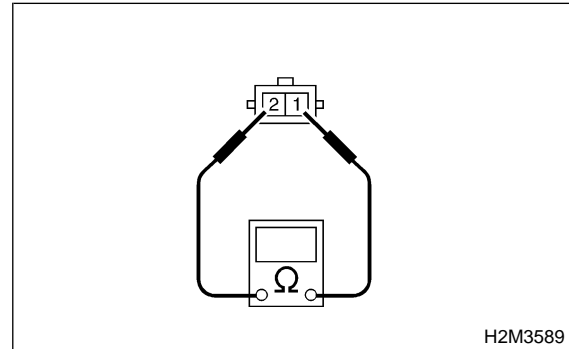

- CHECK** : *Is the resistance between 10 and 100 Ω?*
- YES** : Go to step **10CF6**.
- NO** : Replace fuel tank pressure control solenoid valve. <Ref. to 2-1 [W9A0].>

**10CF6 : CHECK MAIN RELAY.**

- 1) Turn the ignition switch to OFF.
- 2) Remove main relay.
- 3) Connect battery to main relay terminals No. 1 and No. 2.
- 4) Measure resistance between main relay terminals.

**Terminals**  
**No. 3 — No. 5:**

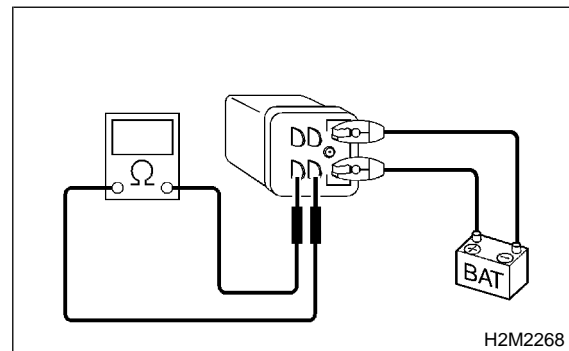

- CHECK** : *Is the resistance less than 10 Ω?*
- YES** : Go to step **10CF7**.
- NO** : Replace main relay.

**10CF7 : CHECK POWER SUPPLY TO FUEL TANK PRESSURE CONTROL SOLENOID VALVE.**

- 1) Turn ignition switch to ON.
- 2) Measure voltage between fuel tank pressure control solenoid valve and chassis ground.

**Connector & terminal**

**(R68) No. 1 (+) — Chassis ground (-):**

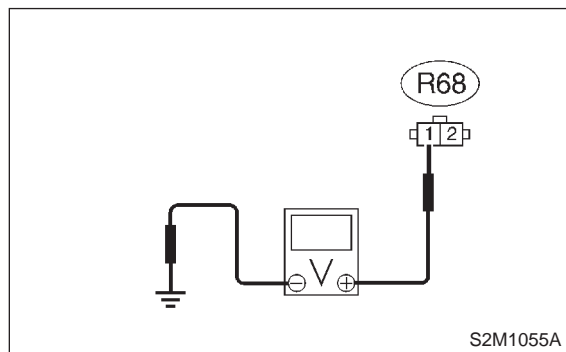

**CHECK** : **Is the voltage more than 10 V?**

**YES** : Go to step **10CF8**.

**NO** : Repair harness and connector.

**NOTE:**

In this case, repair the following:

- Open circuit in harness between battery and fuel tank pressure control solenoid valve connector
- Poor contact in coupling connectors (R57 and B97)
- Poor contact in main relay connector

**10CF8 : CHECK POOR CONTACT.**

Check poor contact in fuel tank pressure control solenoid valve connector. <Ref. to FOREWORD [T3C1].>

**CHECK** : **Is there poor contact in fuel tank pressure control solenoid valve connector?**

**YES** : Repair poor contact in fuel tank pressure control solenoid valve connector.

**NO** : Contact with SOA service.

**NOTE:**

Inspection by DTM is required, because probable cause is deterioration of multiple parts.



**CG: DTC P1420 — FUEL TANK PRESSURE CONTROL SOLENOID VALVE CIRCUIT HIGH INPUT —**

**● DTC DETECTING CONDITION:**

- Two consecutive driving cycles with fault

**CAUTION:**

After repair or replacement of faulty parts, conduct CLEAR MEMORY MODE <Ref. to 2-7 [T3D0].> and INSPECTION MODE <Ref. to 2-7 [T3E0].>

**● WIRING DIAGRAM:**

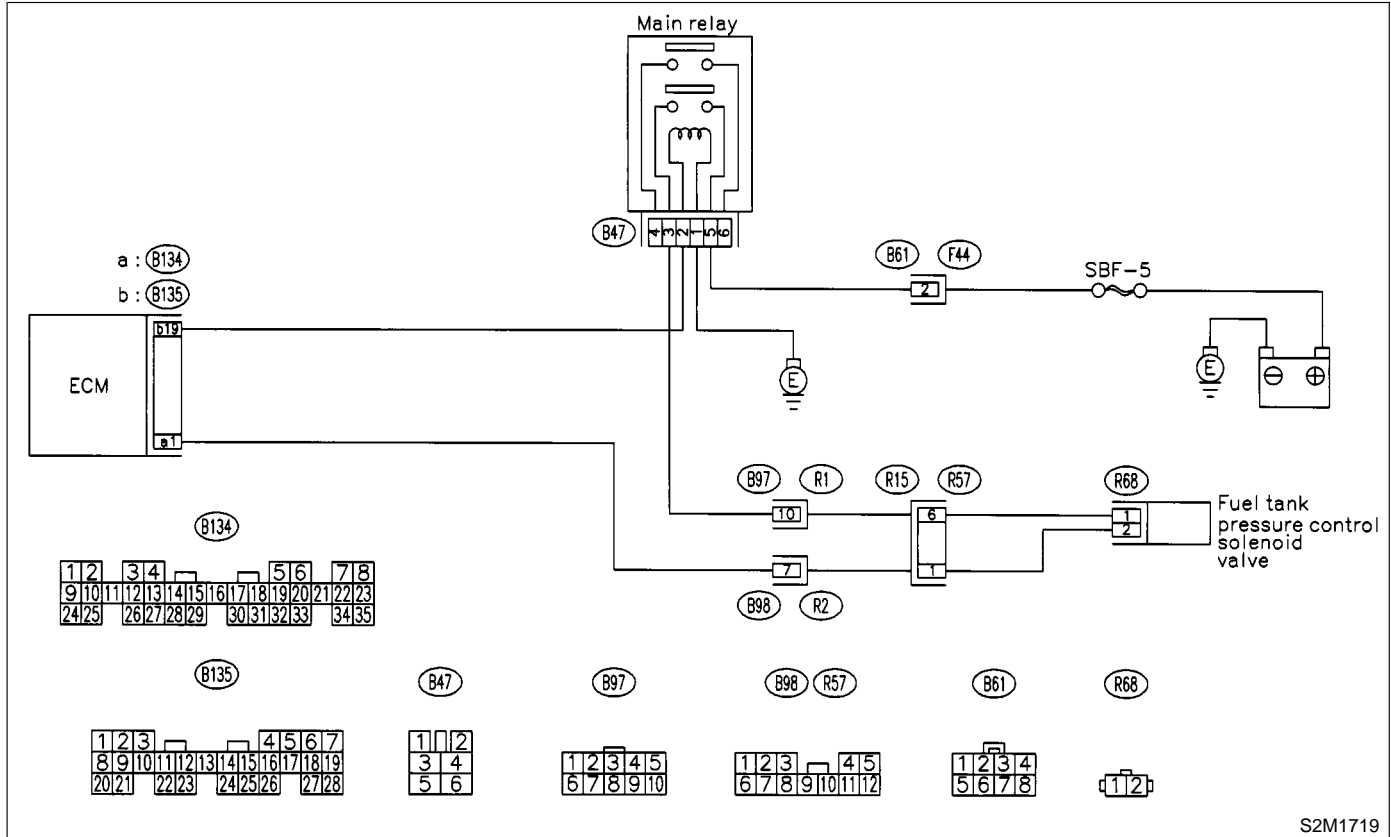

S2M1719

**10CG1 : CHECK OUTPUT SIGNAL FROM ECM.**

- 1) Turn ignition switch to OFF.
- 2) Connect test mode connector at the lower portion of instrument panel (on the driver's side), to the side of the center console box.

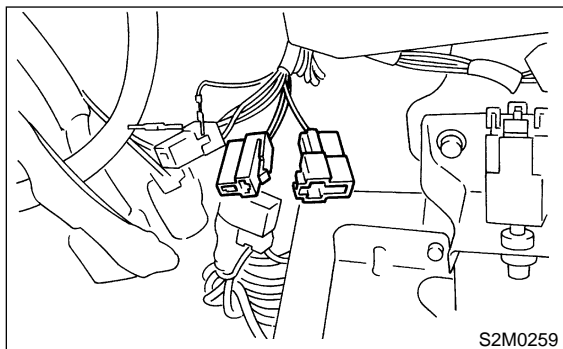

- 3) Turn ignition switch to ON.
- 4) While operating fuel tank pressure control solenoid valve, measure voltage between ECM and chassis ground.

**NOTE:**

Fuel tank pressure control solenoid valve operation can be executed using Subaru Select Monitor. For procedure, refer to "COMPULSORY VALVE OPERATION CHECK MODE". <Ref. to 2-7 [T3F0].>

**Connector & terminal**

**(B134) No. 1 (+) — Chassis ground (-):**

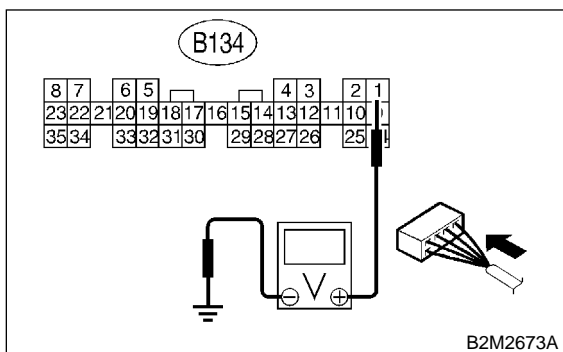

- CHECK** : Does voltage change between 0 and 10 V?
- YES** : Go to step 10CG2.
- NO** : Even if MIL light up, the circuit has returned to a normal condition at this time. In this case, repair poor contact in ECM connector.

**10CG2 : CHECK OUTPUT SIGNAL FROM ECM.**

- 1) Turn ignition switch to ON.
- 2) Measure voltage between ECM and chassis ground.

**Connector & terminal**

**(B134) No. 1 (+) — Chassis ground (-):**

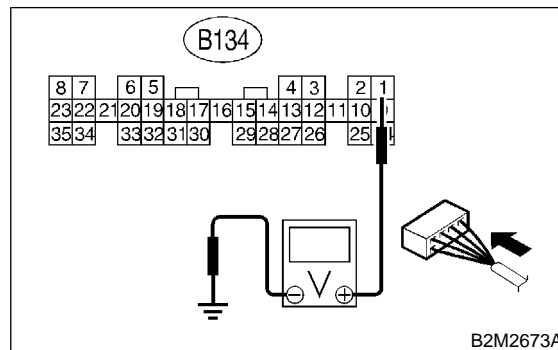

- CHECK** : Is the voltage more than 10 V?
- YES** : Go to step 10CG4.
- NO** : Go to step 10CG3.

**10CG3 : CHECK POOR CONTACT.**

Check poor contact in ECM connector. <Ref. to FOREWORD [T3C1].>

- CHECK** : Is there poor contact in ECM connector?
- YES** : Repair poor contact in ECM connector.
- NO** : Replace ECM. <Ref. to 2-7 [W17A0].>

**10CG4 : CHECK HARNESS BETWEEN FUEL TANK PRESSURE CONTROL SOLENOID VALVE AND ECM CONNECTOR.**

- 1) Turn ignition switch to OFF.
- 2) Disconnect connector from fuel tank pressure control solenoid valve.
- 3) Turn ignition switch to ON.
- 4) Measure voltage between ECM and chassis ground.

**Connector & terminal**

**(B134) No. 1 (+) — Chassis ground (-):**

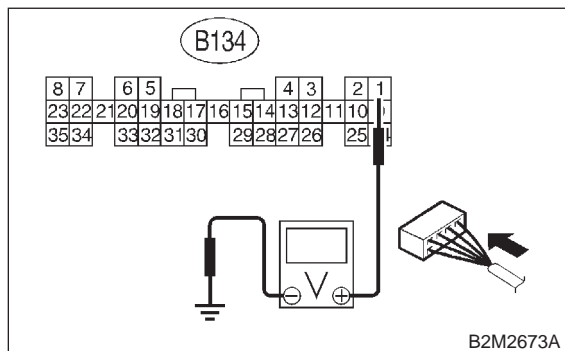

- CHECK** : **Is the voltage more than 10 V?**
- YES** : Repair battery short circuit in harness between ECM and fuel tank pressure control solenoid valve connector. After repair, replace ECM. <Ref. to 2-7 [W17A0].>
- NO** : Go to step **10CG5**.

**10CG5 : CHECK FUEL TANK PRESSURE CONTROL SOLENOID VALVE.**

- 1) Turn ignition switch to OFF.
- 2) Measure resistance between fuel tank pressure control solenoid valve terminals.

**Terminals**

**No. 1 — No. 2:**

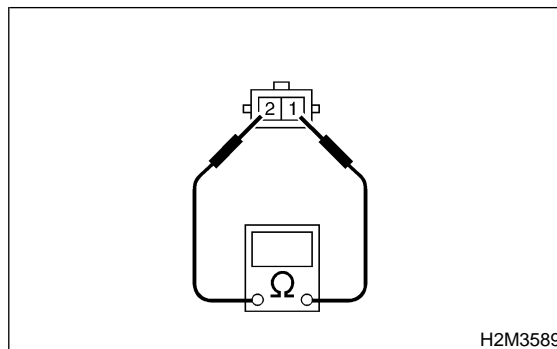

- CHECK** : **Is the resistance less than 1 Ω?**
- YES** : Replace fuel tank pressure control solenoid valve <Ref. to 2-1 [W9A0].> and ECM <Ref. to 2-7 [W17A0].>
- NO** : Go to step **10CG6**.

**10CG6 : CHECK POOR CONTACT.**

Check poor contact in ECM connector. <Ref. to FOREWORD [T3C1].>

- CHECK** : **Is there poor contact in ECM connector?**
- YES** : Repair poor contact in ECM connector.
- NO** : Replace ECM. <Ref. to 2-7 [W17A0].>

**MEMO:**

**CH: DTC P1422 — EVAPORATIVE EMISSION CONTROL SYSTEM PURGE CONTROL VALVE CIRCUIT HIGH INPUT —**

- **DTC DETECTING CONDITION:**
  - Two consecutive driving cycles with fault
- **TROUBLE SYMPTOM:**
  - Erroneous idling

**CAUTION:**

After repair or replacement of faulty parts, conduct CLEAR MEMORY MODE <Ref. to 2-7 [T3D0].> and INSPECTION MODE <Ref. to 2-7 [T3E0].>

● **WIRING DIAGRAM:**

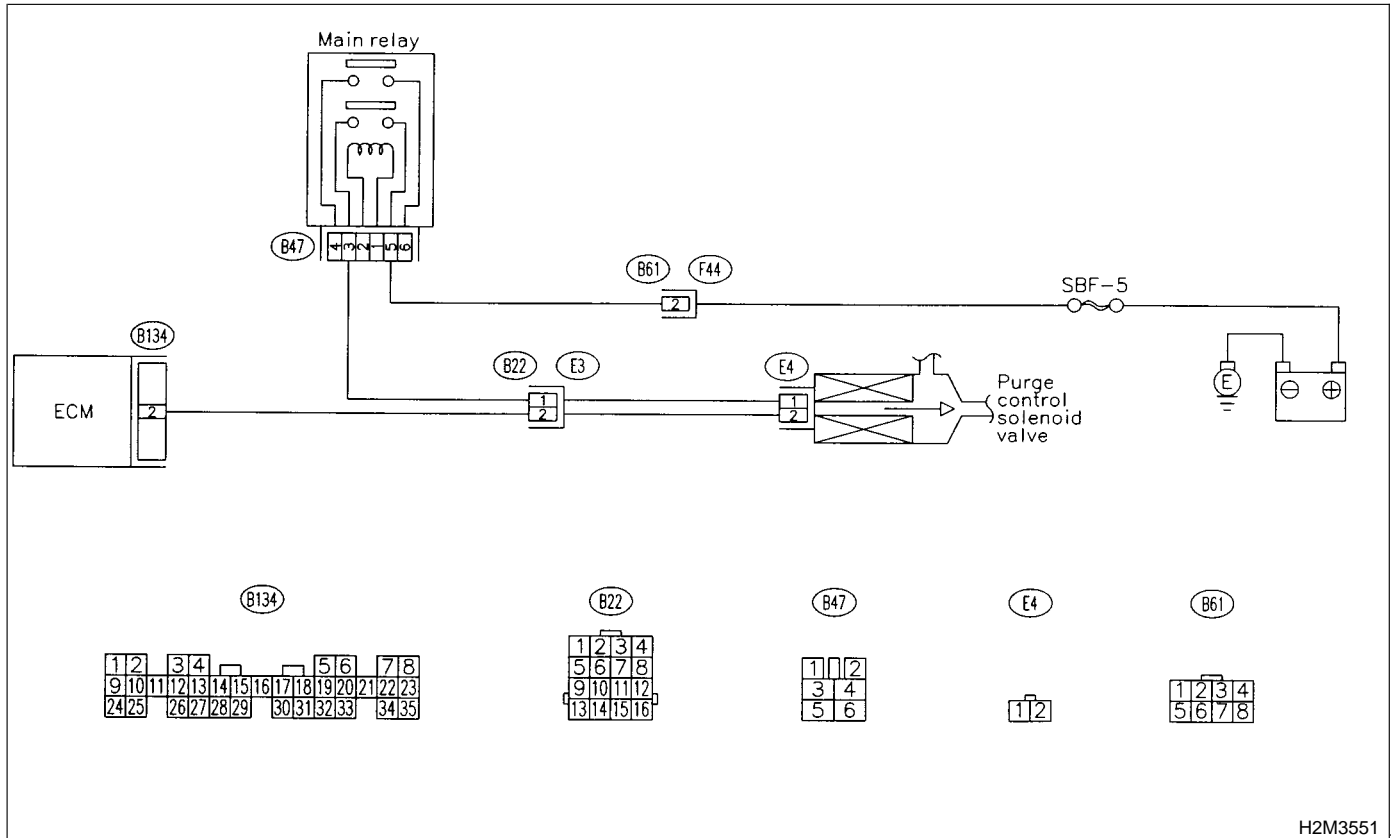

H2M3551

**10CH1 : CHECK OUTPUT SIGNAL FROM ECM.**

- 1) Turn ignition switch to OFF.
- 2) Connect test mode connector at the lower portion of instrument panel (on the driver's side), to the side of the center console box.

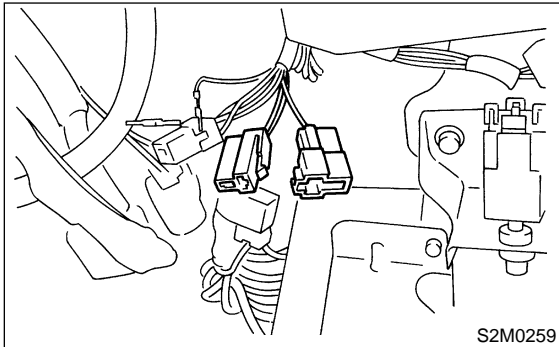

- 3) Turn ignition switch to ON.
- 4) While operating purge control solenoid valve, measure voltage between ECM and chassis ground.

**NOTE:**

Purge control solenoid valve operation can be executed using Subaru Select Monitor. For procedure, refer to "COMPULSORY VALVE OPERATION CHECK MODE". <Ref. to 2-7 [T3F0].>

**Connector & terminal**

**(B134) No. 2 (+) — Chassis ground (-):**

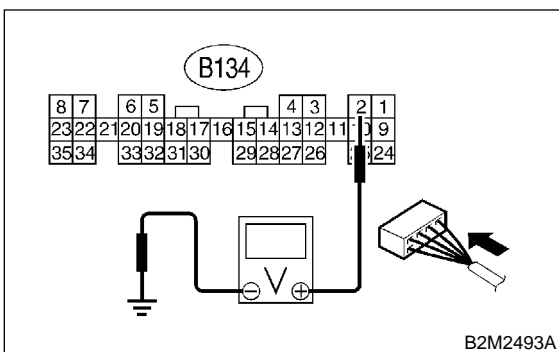

- CHECK** : Does voltage change between 0 and 10 V?
- YES** : Go to step 10CH2.
- NO** : Even if MIL light up, the circuit has returned to a normal condition at this time. In this case, repair poor contact in ECM connector.

**10CH2 : CHECK OUTPUT SIGNAL FROM ECM.**

- 1) Turn ignition switch to ON.
- 2) Measure voltage between ECM and chassis ground.

**Connector & terminal**

**(B134) No. 2 (+) — Chassis ground (-):**

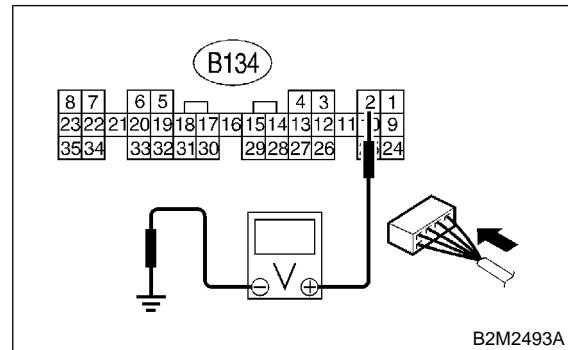

- CHECK** : Is the voltage more than 10 V?
- YES** : Go to step 10CH4.
- NO** : Go to step 10CH3.

**10CH3 : CHECK POOR CONTACT.**

Check poor contact in ECM connector. <Ref. to FOREWORD [T3C1].>

- CHECK** : Is there poor contact in ECM connector?
- YES** : Repair poor contact in ECM connector.
- NO** : Replace ECM. <Ref. to 2-7 [W17A0].>

**10CH4 : CHECK HARNESS BETWEEN PURGE CONTROL SOLENOID VALVE AND ECM CONNECTOR.**

- 1) Turn ignition switch to OFF.
- 2) Disconnect connector from purge control solenoid valve.
- 3) Turn ignition switch to ON.
- 4) Measure voltage between ECM and chassis ground.

**Connector & terminal**

**(B134) No. 2 (+) — Chassis ground (-):**

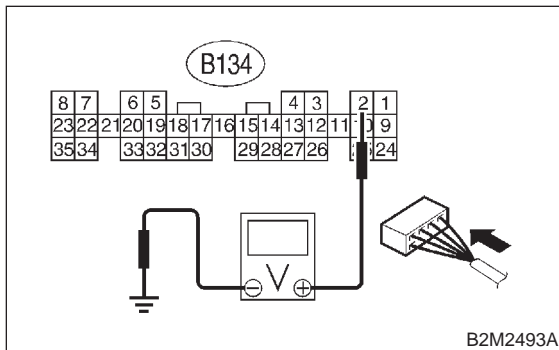

- CHECK** : **Is the voltage more than 10 V?**
- YES** : Repair battery short circuit in harness between ECM and purge control solenoid valve connector. After repair, replace ECM. <Ref. to 2-7 [W17A0].>
- NO** : Go to step **10CH5**.

**10CH5 : CHECK PURGE CONTROL SOLENOID VALVE.**

- 1) Turn ignition switch to OFF.
- 2) Measure resistance between purge control solenoid valve terminals.

**Terminals**

**No. 1 — No. 2:**

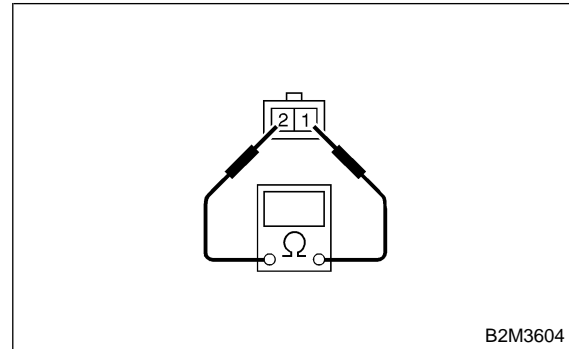

- CHECK** : **Is the resistance less than 1 Ω?**
- YES** : Replace purge control solenoid valve <Ref. to 2-1 [W17A0].> and ECM <Ref. to 2-7 [W17A0].>
- NO** : Go to step **10CH6**.

**10CH6 : CHECK POOR CONTACT.**

Check poor contact in ECM connector. <Ref. to FOREWORD [T3C1].>

- CHECK** : **Is there poor contact in ECM connector?**
- YES** : Repair poor contact in ECM connector.
- NO** : Replace ECM. <Ref. to 2-7 [W17A0].>

**MEMO:**



**CI: DTC P1423 — EVAPORATIVE EMISSION CONTROL SYSTEM VENT CONTROL HIGH INPUT —**

- **DTC DETECTING CONDITION:**
  - Two consecutive driving cycles with fault

**CAUTION:**

After repair or replacement of faulty parts, conduct CLEAR MEMORY MODE <Ref. to 2-7 [T3D0].> and INSPECTION MODE <Ref. to 2-7 [T3E0].>

● **WIRING DIAGRAM:**

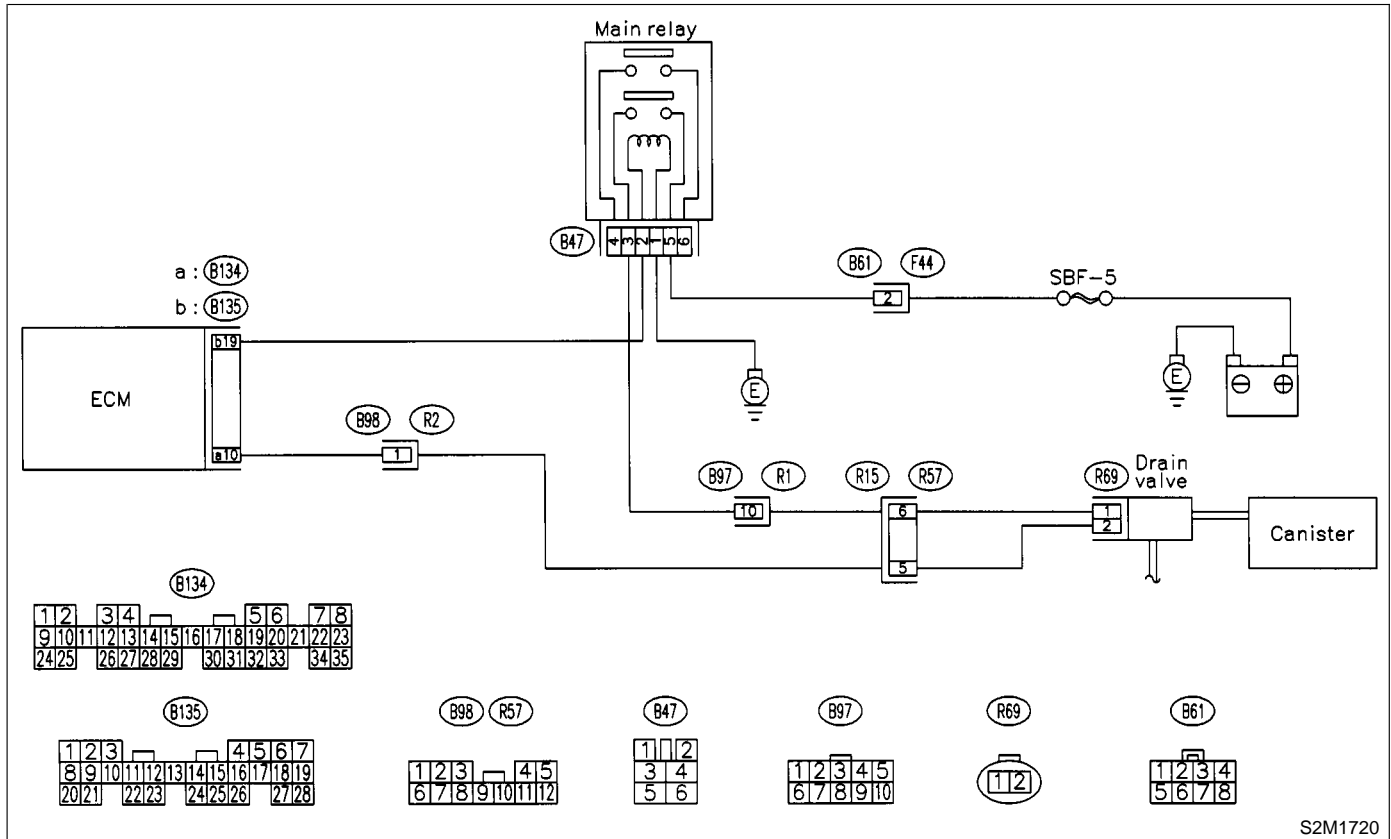

S2M1720

**10C11 : CHECK OUTPUT SIGNAL FROM ECM.**

- 1) Turn ignition switch to OFF.
- 2) Connect test mode connector at the lower portion of instrument panel (on the driver's side), to the side of the center console box.

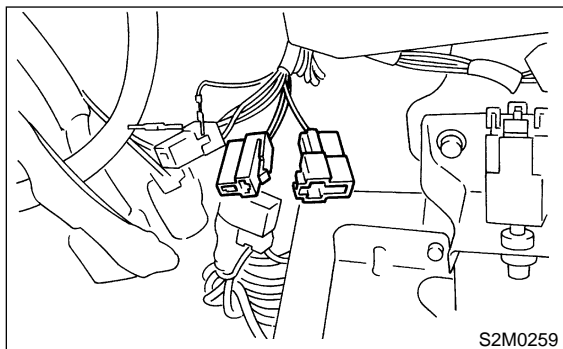

- 3) Turn ignition switch to ON.
- 4) While operating drain valve, measure voltage between ECM and chassis ground.

**NOTE:**

Drain valve operation can be executed using Subaru Select Monitor. For procedure, refer to "COMPULSORY VALVE OPERATION CHECK MODE". <Ref. to 2-7 [T3F0].>

**Connector & terminal**

**(B134) No. 10 (+) — Chassis ground (-):**

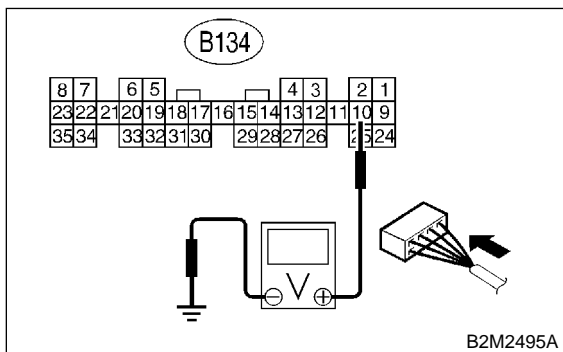

- CHECK** : Does voltage change between 0 and 10 V?
- YES** : Go to step 10C12.
- NO** : Even if MIL light up, the circuit has returned to a normal condition at this time. In this case, repair poor contact in ECM connector.

**10C12 : CHECK OUTPUT SIGNAL FROM ECM.**

- 1) Turn ignition switch to ON.
- 2) Measure voltage between ECM and chassis ground.

**Connector & terminal**

**(B134) No. 10 (+) — Chassis ground (-):**

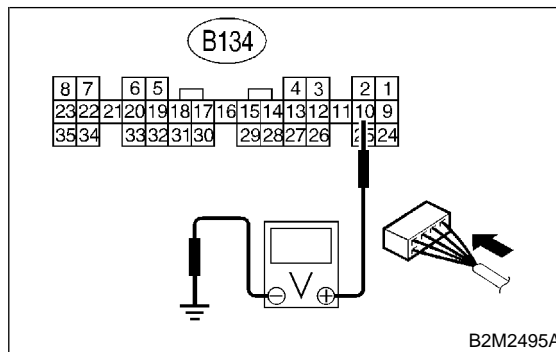

- CHECK** : Is the voltage more than 10 V?
- YES** : Go to step 10C14.
- NO** : Go to step 10C13.

**10C13 : CHECK POOR CONTACT.**

Check poor contact in ECM connector. <Ref. to FOREWORD [T3C1].>

- CHECK** : Is there poor contact in ECM connector?
- YES** : Repair poor contact in ECM connector.
- NO** : Replace ECM. <Ref. to 2-7 [W17A0].>

**10C14 : CHECK HARNESS BETWEEN DRAIN VALVE AND ECM CONNECTOR.**

- 1) Turn ignition switch to OFF.
- 2) Disconnect connector from drain valve.
- 3) Turn ignition switch to ON.
- 4) Measure voltage between ECM and chassis ground.

**Connector & terminal**

**(B134) No. 10 (+) — Chassis ground (-):**

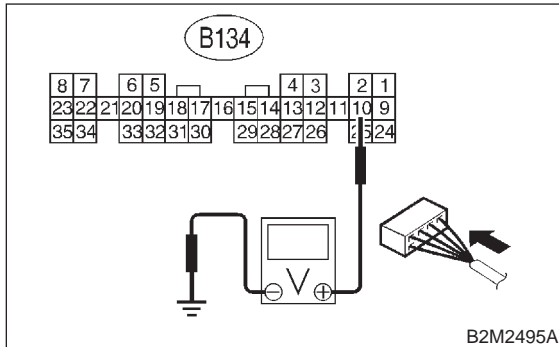

- CHECK** : **Is the voltage more than 10 V?**
- YES** : Repair battery short circuit in harness between ECM and drain valve connector. After repair, replace ECM. <Ref. to 2-7 [W17A0].>
- NO** : Go to step **10C15**.

**10C15 : CHECK DRAIN VALVE.**

- 1) Turn ignition switch to OFF.
- 2) Measure resistance between drain valve terminals.

**Terminals**

**No. 1 — No. 2:**

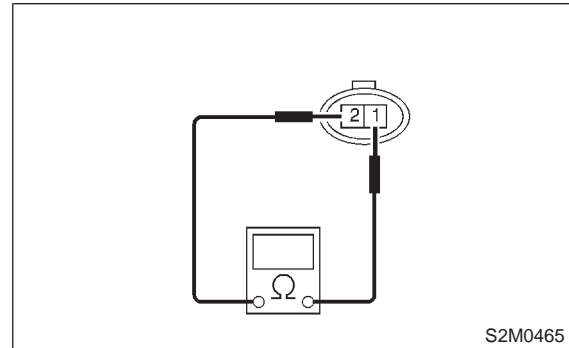

- CHECK** : **Is the resistance less than 1 Ω?**
- YES** : Replace drain valve <Ref. to 2-1 [W13A0].> and ECM <Ref. to 2-7 [W17A0].>
- NO** : Go to step **10C16**.

**10C16 : CHECK POOR CONTACT.**

Check poor contact in ECM connector. <Ref. to FOREWORD [T3C1].>

- CHECK** : **Is there poor contact in ECM connector?**
- YES** : Repair poor contact in ECM connector.
- NO** : Replace ECM. <Ref. to 2-7 [W17A0].>

### CJ: DTC P1442 — FUEL LEVEL SENSOR CIRCUIT RANGE/PERFORMANCE PROBLEM 2 —

- **DTC DETECTING CONDITION:**
  - Two consecutive driving cycles with fault

**CAUTION:**

After repair or replacement of faulty parts, conduct CLEAR MEMORY MODE <Ref. to 2-7 [T3D0].> and INSPECTION MODE <Ref. to 2-7 [T3E0].>

● **WIRING DIAGRAM:**

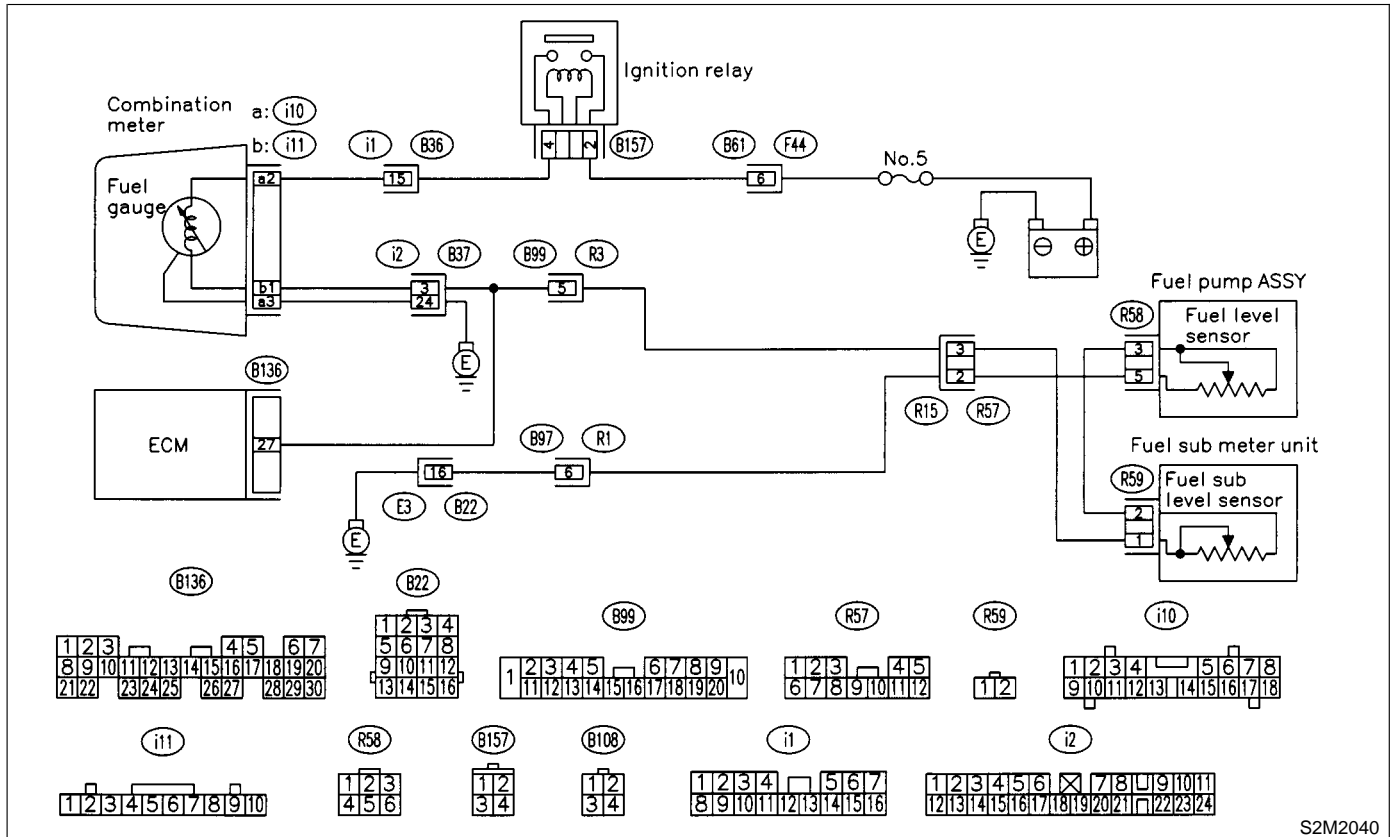

S2M2040

**10CJ1 : CHECK ANY OTHER DTC ON DISPLAY.**

**CHECK** : Does the Subaru Select Monitor or OBD-II general scan tool indicate DTC P0461, P0462 or P0463?

**YES** : Inspect DTC P0461, P0462 or P0463 using "10. Diagnostics Chart with Trouble Code". <Ref. to 2-7 [T10A0].>

**NOTE:**

In this case, it is not necessary to inspect this trouble.

**NO** : Replace fuel level sensor <Ref. to 2-8 [W5A0].> and fuel sub level sensor. <Ref. to 2-8 [W6A0].>

**CK: DTC P1443 — EVAPORATIVE EMISSION CONTROL SYSTEM VENT CONTROL FUNCTION PROBLEM —**

- **DTC DETECTING CONDITION:**
  - Immediately after fault occurrence
- **TROUBLE SYMPTOM:**
  - Improper fuel supply

**CAUTION:**

After repair or replacement of faulty parts, conduct CLEAR MEMORY MODE <Ref. to 2-7 [T3D0].> and INSPECTION MODE <Ref. to 2-7 [T3E0].>

● **WIRING DIAGRAM:**

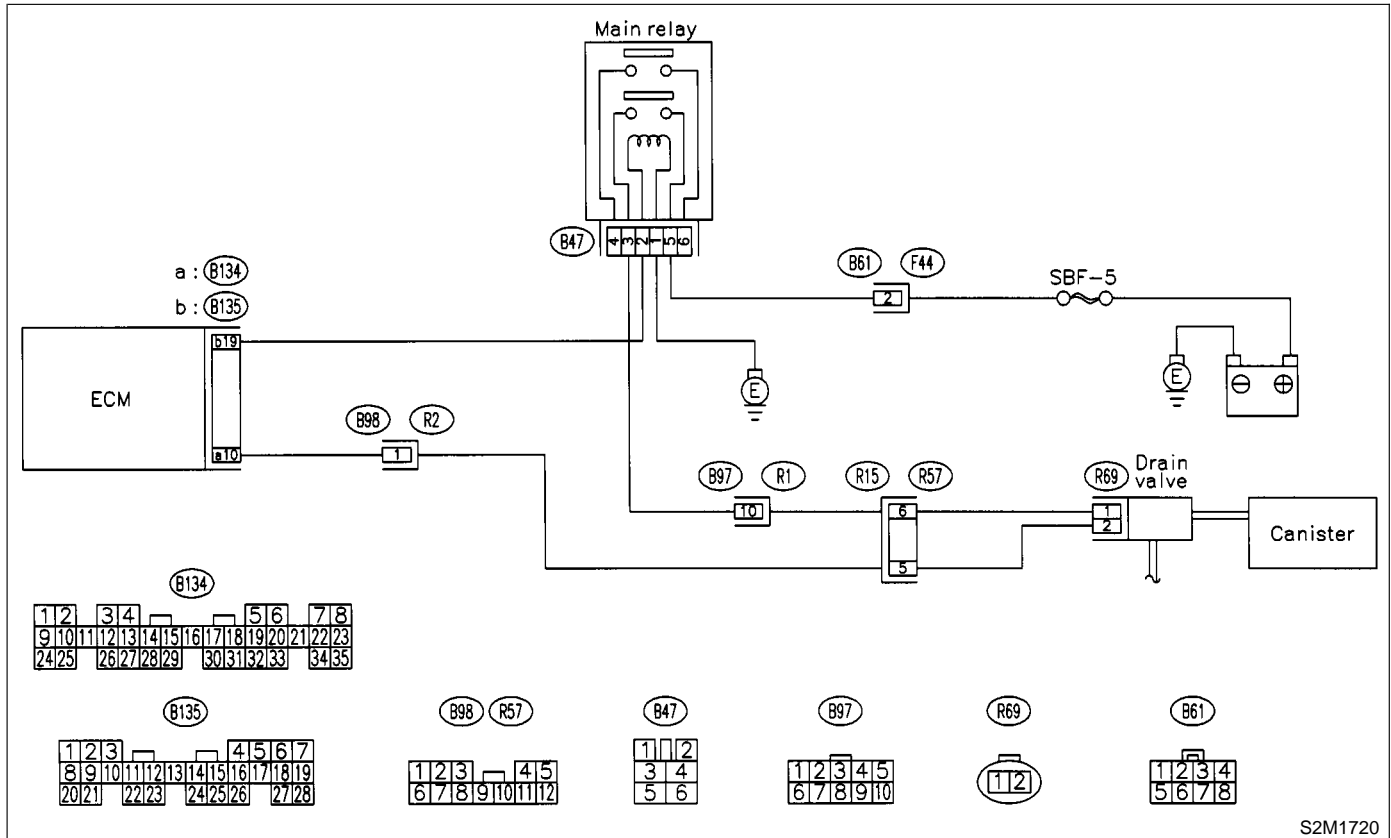

S2M1720

**10CK1 : CHECK ANY OTHER DTC ON DISPLAY.**

- CHECK** : *Is there any other DTC on display?*
- YES** : Inspect the relevant DTC using “10. Diagnostics Chart with Trouble Code”. <Ref. to 2-7 [T10A0].>
- NO** : Go to step **10CK2**.

**10CK2 : CHECK VENT LINE HOSES.**

Check the following items.

- Clogging of vent hoses (A) between canister (B) and drain valve (C)
- Clogging of vent hose (A) between drain valve (C) and drain filter (D)
- Clogging of vent hose (A) between drain filter (D) and junction pipe (E)
- Clogging of junction pipe (E)
- Clogging of drain filter (D)

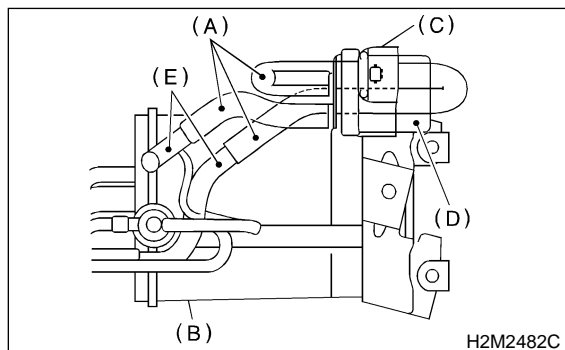

- CHECK** : **Is there a fault in vent line?**
- YES** : Repair or replace the faulty part.
- NO** : Go to step **10CK3**.

**10CK3 : CHECK DRAIN VALVE OPERATION.**

- 1) Turn ignition switch to OFF.
- 2) Connect test mode connector at the lower portion of instrument panel (on the driver's side), to the side of the center console box.

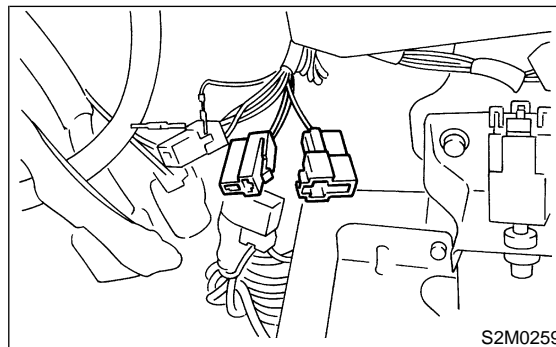

- 3) Turn ignition switch to ON.
- 4) Operate drain valve.

**NOTE:**

Drain valve operation can also be executed using Subaru Select Monitor. For the procedure, refer to the "COMPULSORY VALVE OPERATION CHECK MODE". <Ref. to 2-7 [T3F0].>

- CHECK** : **Does drain valve produce operating sound?**

- YES** : Contact with SOA service.

**NOTE:**

Inspection by DTM is required, because probable cause is deterioration of multiple parts.

- NO** : Replace drain valve. <Ref. to 2-1 [W13A0].>

**CL: DTC P1445 — AIR ASSIST INJECTOR SOLENOID VALVE MALFUNCTION**

- **DTC DETECTING CONDITION:**
  - Immediately after fault occurrence
- **TROUBLE SYMPTOM:**
  - Erroneous idling
  - Engine stalls.

**CAUTION:**

After repair or replacement of faulty parts, conduct CLEAR MEMORY MODE <Ref. to 2-7 [T3D0].> and INSPECTION MODE <Ref. to 2-7 [T3E0].>

● **WIRING DIAGRAM:**

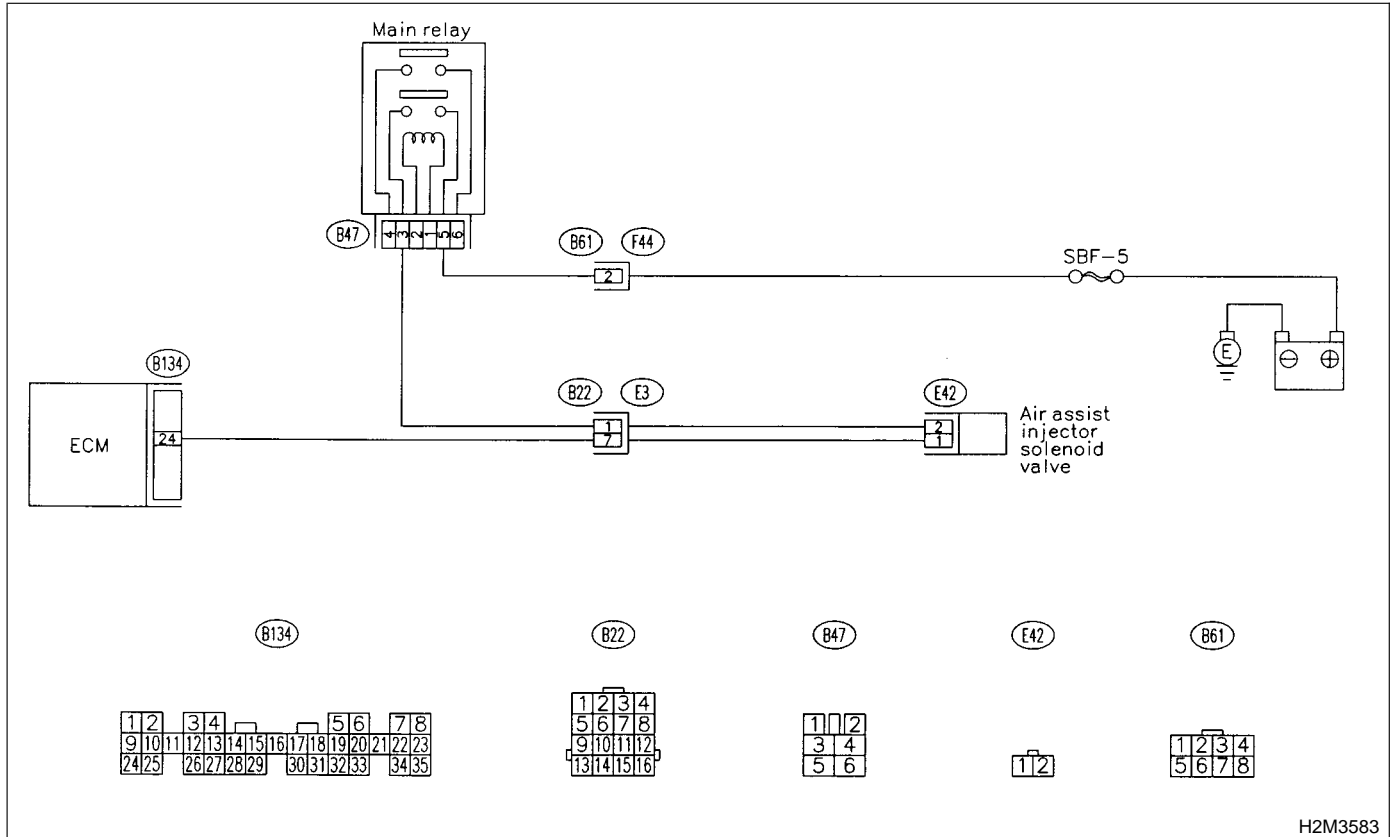

H2M3583

**10CL1 : CHECK ANY OTHER DTC ON DISPLAY.**

- CHECK** : *Is there any other DTC on display?*
- YES** : Inspect the relevant DTC using "10. Diagnostics Chart with Trouble Code". <Ref. to 2-7 [T10A0].>
- NO** : Go to step **10CL2**.

**10CL2 : CHECK AIR ASSIST INJECTOR SOLENOID VALVE OPERATION.**

- 1) Turn ignition switch to OFF.
- 2) Connect test mode connector at the lower portion of instrument panel (on the driver's side), to the side of the center console box.

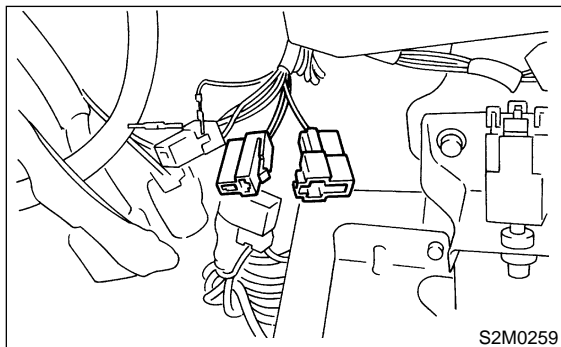

- 3) Turn ignition switch to ON.
- 4) Operate air assist injector solenoid valve.

**NOTE:**

Air assist injector solenoid valve operation can also be executed using Subaru Select Monitor. For the procedure, refer to the "COMPULSORY VALVE OPERATION CHECK MODE". <Ref. to 2-7 [T3F0].>

**CHECK** : ***Does air assist injector solenoid valve operating sound?***

**YES** : Go to step **10CL3**.

**NO** : Replace air assist injector solenoid valve. <Ref. to 2-1 [W14A0].>

**10CL3 : CHECK AIR BY-PASS HOSES.**

Use your mouth to blow through air by-pass hose to make sure that there is a smooth air flow (no clogging).

**CHECK** : ***Is air by-pass hose damaged?***

**YES** : Repair or replace air by-pass hoses.

**NO** : Go to step **10CL4**.

**10CL4 : CHECK FUEL INJECTOR.**

- 1) Turn ignition switch to OFF.
- 2) Remove fuel injector. <Ref. to 2-7 [W16A0].>
- 3) Check for clogged fuel injectors.

**CHECK** : ***Is fuel injector clogged?***

**YES** : Replace fuel injector. <Ref. to 2-7 [W16A0].>

**NO** : Replace air assist injector solenoid valve. <Ref. to 2-7 [W14A0].>



**CM: DTC P1490 — THERMOSTAT MALFUNCTION —**

- **DTC DETECTING CONDITION:**
  - Immediately at fault recognition
- **TROUBLE SYMPTOM:**
  - Thermostat remains open.

**CAUTION:**

After repair or replacement of faulty parts, conduct CLEAR MEMORY MODE <Ref. to 2-7 [T3D0].> and INSPECTION MODE <Ref. to 2-7 [T3E0].>.

**10CM1 : CHECK VEHICLE CONDITION.**

- CHECK** : *Has engine operated at idle or has vehicle been driven with part of engine submerged under water?*
- YES** : In this case, it is not necessary to inspect DTC P1490.
- NO** : Go to step **10CM2**.

**10CM2 : CHECK ANY OTHER DTC ON DISPLAY.**

- CHECK** : *Does the Subaru Select Monitor or OBD-II general scan tool indicate DTC P0125, P0301, P0302, P0303 and P0304 at same time?*
- YES** : Go to step **10CM3**.
- NO** : Inspect DTC P0125, P0301, P0302, P0303 and P0304 using "10. Diagnostics Chart with Trouble Code". <Ref. to 2-7 [T10A0].>

**10CM3 : CHECK ENGINE COOLANT.**

- CHECK** : *Are coolant level and mixture ratio of cooling water to anti-freeze solution correct?*
- YES** : Go to step **10CM4**.
- NO** : Replace engine coolant. <Ref. to 2-5 [W9A0].>

**10CM4 : CHECK RADIATOR FAN.**

- 1) Start the engine.
  - 2) Check radiator fan operation.
- CHECK** : *Does radiator fan continuously rotate for more than 3 minutes during idling?*
- YES** : Repair radiator fan circuit. <Ref. to 2-5 [T100].>
- NO** : Replace thermostat. <Ref. to 2-5 [W2A0].>

**MEMO:**

**CN: DTC P1507 — IDLE CONTROL SYSTEM MALFUNCTION (FAIL-SAFE) —**

**● DTC DETECTING CONDITION:**

- Two consecutive driving cycles with fault

**● TROUBLE SYMPTOM:**

- Engine keeps running at higher revolution than specified idling revolution.

**CAUTION:**

After repair or replacement of faulty parts, conduct CLEAR MEMORY MODE <Ref. to 2-7 [T3D0].> and INSPECTION MODE <Ref. to 2-7 [T3E0].>

**● WIRING DIAGRAM:**

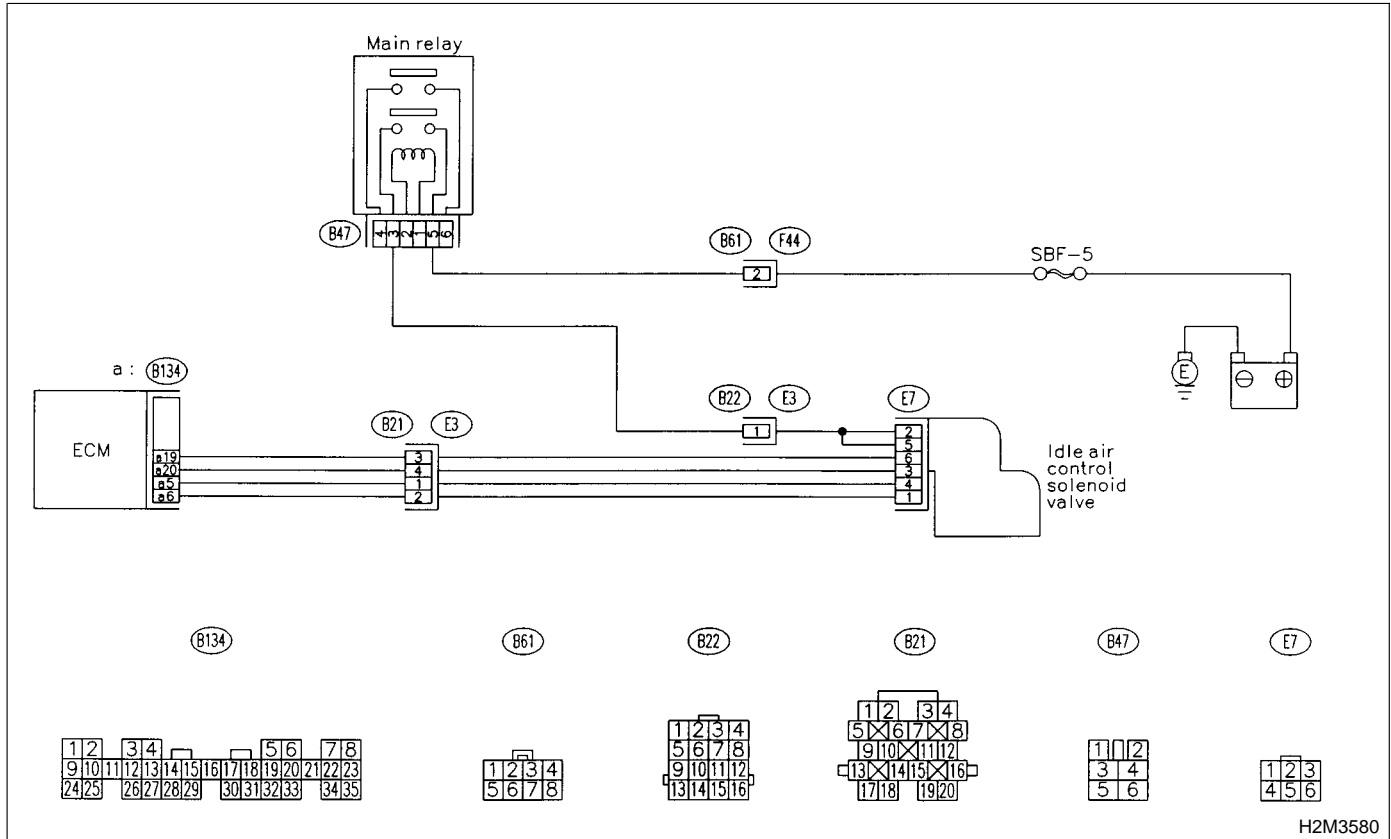

H2M3580

**10CN1 : CHECK ANY OTHER DTC ON DISPLAY.**

**CHECK** : Does the Subaru Select Monitor or OBD-II general scan tool indicate DTC P1510, P1511, P1512, P1513, P1514, P1515, P1516 or P1517?

**YES** : Inspect DTC P1510, P1511, P1512, P1513, P1514, P1515, P1516 or P1517 using "10. Diagnostics Chart with Trouble Code". <Ref. to 2-7 [T10A0].>

**NOTE:**

In this case, it is not necessary to inspect DTC P0507.

**NO** : Go to step 10CN2.

**10CN2 : CHECK AIR INTAKE SYSTEM.**

- 1) Turn ignition switch to ON.
- 2) Start engine, and idle it.
- 3) Check the following items.
  - Loose installation of intake manifold, idle air control solenoid valve and throttle body
  - Cracks of intake manifold gasket, idle air control solenoid valve gasket and throttle body gasket
  - Disconnections of vacuum hoses

**CHECK** : Is there a fault in air intake system?

**YES** : Repair air suction and leaks.

**NO** : Go to step 10CN3.

**10CN3 : CHECK THROTTLE CABLE.**

- CHECK** : *Does throttle cable have play for adjustment?*
- YES** : Go to step **10CN4**.
- NO** : Adjust throttle cable. <Ref. to 4-5 [W1A3].>

**10CN4 : CHECK AIR BY-PASS LINE.**

- 1) Turn ignition switch to OFF.
- 2) Remove idle air control solenoid valve from throttle body. <Ref. to 2-7 [W15A2].>
- 3) Confirm that there are no foreign particles in by-pass air line.

- CHECK** : *Are foreign particles in by-pass air line?*
- YES** : Remove foreign particles from by-pass air line.
- NO** : Replace idle air control solenoid valve. <Ref. to 2-7 [W13A0].>

**MEMO:**

**CO: DTC P1510 — IDLE AIR CONTROL SOLENOID VALVE SIGNAL 1  
CIRCUIT LOW INPUT —****NOTE:**

For the diagnostic procedure, refer to DTC P1516. <Ref. to 2-7 [T10CU0].>

**CP: DTC P1511 — IDLE AIR CONTROL SOLENOID VALVE SIGNAL 1  
CIRCUIT HIGH INPUT —****NOTE:**

For the diagnostic procedure, refer to DTC P1517. <Ref. to 2-7 [T10CV0].>

**CQ: DTC P1512 — IDLE AIR CONTROL SOLENOID VALVE SIGNAL 2  
CIRCUIT LOW INPUT —****NOTE:**

For the diagnostic procedure, refer to DTC P1516. <Ref. to 2-7 [T10CU0].>

**CR: DTC P1513 — IDLE AIR CONTROL SOLENOID VALVE SIGNAL 2  
CIRCUIT HIGH INPUT —****NOTE:**

For the diagnostic procedure, refer to DTC P1517. <Ref. to 2-7 [T11CV0].>

**CS: DTC P1514 — IDLE AIR CONTROL SOLENOID VALVE SIGNAL 3  
CIRCUIT LOW INPUT —****NOTE:**

For the diagnostic procedure, refer to DTC P1516. <Ref. to 2-7 [T11CU0].>

**CT: DTC P1515 — IDLE AIR CONTROL SOLENOID VALVE SIGNAL 3  
CIRCUIT HIGH INPUT —****NOTE:**

For the diagnostic procedure, refer to DTC P1517. <Ref. to 2-7 [T10CV0].>

**CU: DTC P1516 — IDLE AIR CONTROL SOLENOID VALVE SIGNAL 4  
CIRCUIT LOW INPUT —**

- **DTC DETECTING CONDITION:**
  - Immediately at fault recognition
- **TROUBLE SYMPTOM:**
  - Erroneous idling
  - Engine stalls.
  - Engine breathing

**CAUTION:**

After repair or replacement of faulty parts, conduct CLEAR MEMORY MODE <Ref. to 2-7 [T3D0].> and INSPECTION MODE <Ref. to 2-7 [T3E0].>

● **WIRING DIAGRAM:**

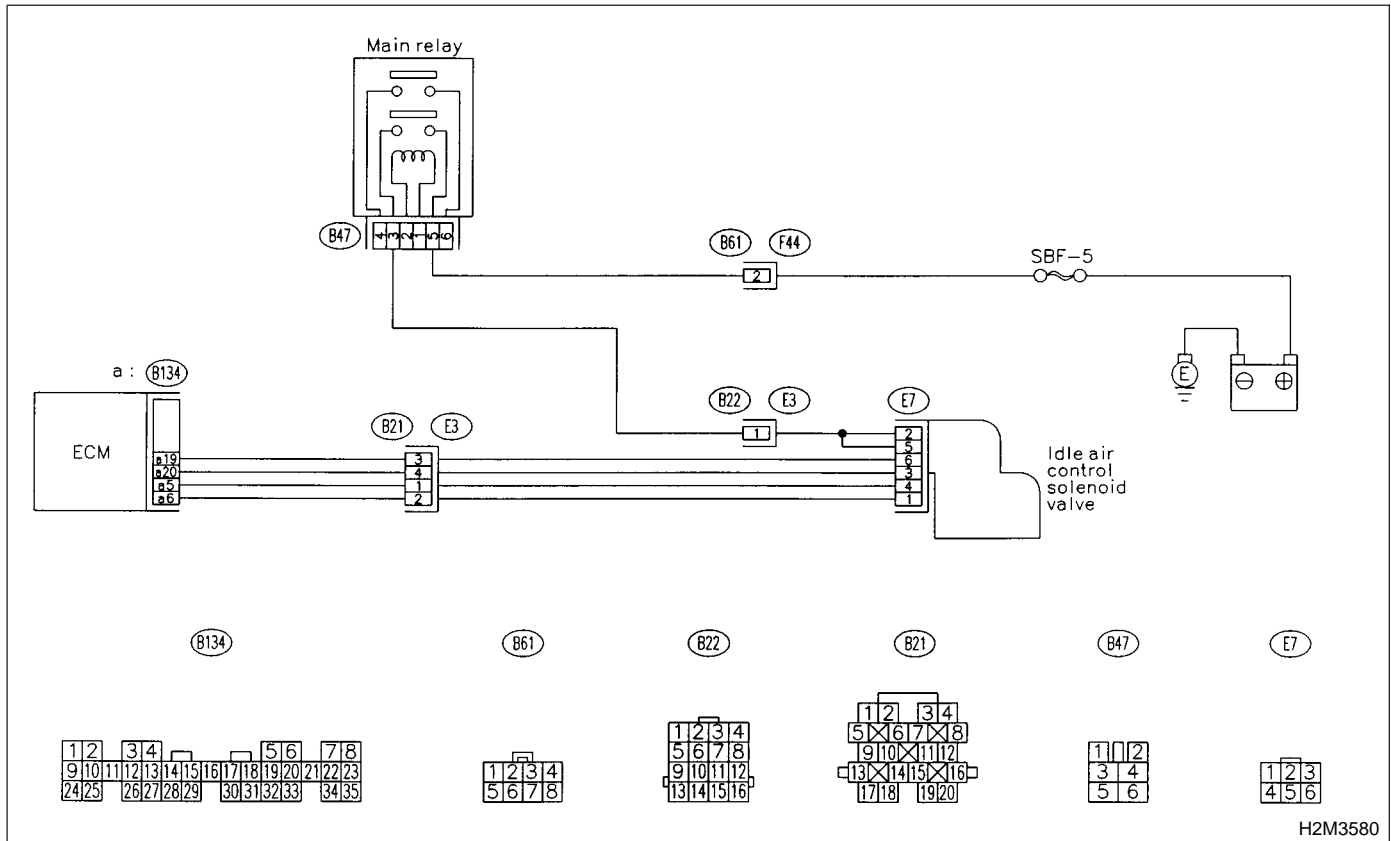

H2M3580

**10CU1 : CHECK POWER SUPPLY TO IDLE AIR CONTROL SOLENOID VALVE.**

- 1) Turn ignition switch to OFF.
- 2) Disconnect connector from idle air control solenoid valve.
- 3) Turn ignition switch to ON.
- 4) Measure voltage between idle air control solenoid valve connector and engine ground.

**Connector & terminal**

- (E7) No. 2 (+) — Engine ground (-):
- (E7) No. 5 (+) — Engine ground (-):

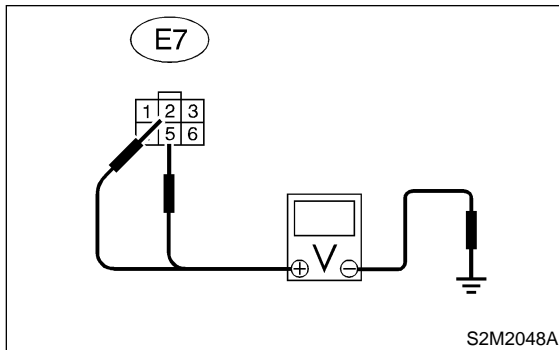

- CHECK** : Is the voltage more than 10 V?
- YES** : Go to step 10CU2.
- NO** : Repair harness and connector.

**NOTE:**

In this case, repair the following:

- Open circuit in harness between idle air control solenoid valve and main relay connector
- Poor contact in coupling connector (B22)

**10CU2 : CHECK HARNESS BETWEEN ECM AND IDLE AIR CONTROL SOLENOID VALVE CONNECTOR.**

- 1) Turn ignition switch to OFF.
- 2) Measure resistance between ECM and idle air control solenoid valve connector.

**Connector & terminal**

- DTC P1510; (B134) No. 5 — (E7) No. 3:
- DTC P1512; (B134) No. 6 — (E7) No. 1:
- DTC P1514; (B134) No. 19 — (E7) No. 6:
- DTC P1516; (B134) No. 20 — (E7) No. 4:

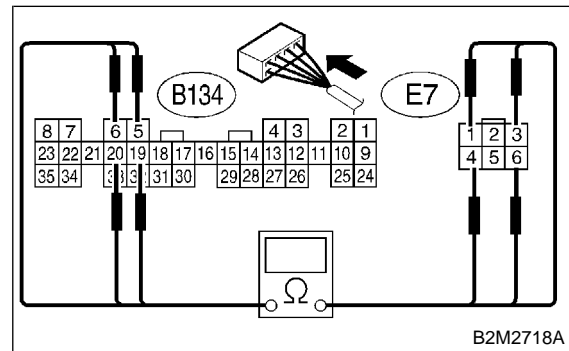

- CHECK** : Is the resistance less than 1 Ω?
- YES** : Go to step 10CU3.
- NO** : Repair harness and connector.

**NOTE:**

In this case, repair the following:

- Open circuit in harness between ECM and idle air control solenoid valve connector
- Poor contact in coupling connector (B21)



**10CU3 : CHECK HARNESS BETWEEN ECM AND IDLE AIR CONTROL SOLENOID VALVE CONNECTOR.**

- 1) Disconnect connector from ECM.
- 2) Measure resistance between ECM connector and chassis ground.

**Connector & terminal**

**DTC P1510; (B134) No. 5 — Chassis ground:**

**DTC P1512; (B134) No. 6 — Chassis ground:**

**DTC P1514; (B134) No. 19 — Chassis ground:**

**DTC P1516; (B134) No. 20 — Chassis ground:**

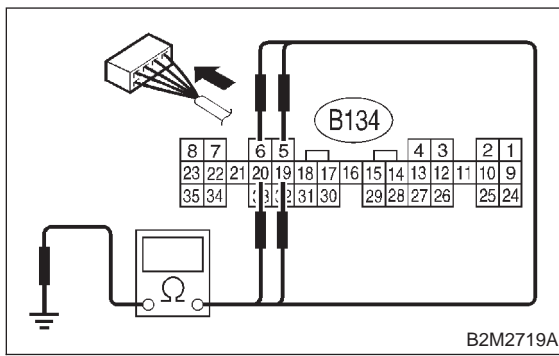

- CHECK** : **Is the resistance less than 10 Ω?**
- YES** : Repair ground short circuit in harness between ECM and idle air control solenoid valve connector.
- NO** : Go to step **10CU4**.

**10CU4 : CHECK POOR CONTACT.**

Check poor contact in ECM connector and idle air control solenoid valve connector. <Ref. to FOREWORD [T3C1].>

- CHECK** : **Is there poor contact in ECM connector or idle air control solenoid valve connector?**
- YES** : Repair poor contact in ECM connector or idle air control solenoid valve connector.
- NO** : Replace idle air control solenoid valve. <Ref. to 2-7 [W13A0].>

MEMO:

**CV: DTC P1517 — IDLE AIR CONTROL SOLENOID VALVE SIGNAL 4 CIRCUIT HIGH INPUT —**

- **DTC DETECTING CONDITION:**
  - Immediately at fault recognition
- **TROUBLE SYMPTOM:**
  - Erroneous idling
  - Engine stalls.
  - Engine breathing

**CAUTION:**

After repair or replacement of faulty parts, conduct CLEAR MEMORY MODE <Ref. to 2-7 [T3D0].> and INSPECTION MODE <Ref. to 2-7 [T3E0].>

● **WIRING DIAGRAM:**

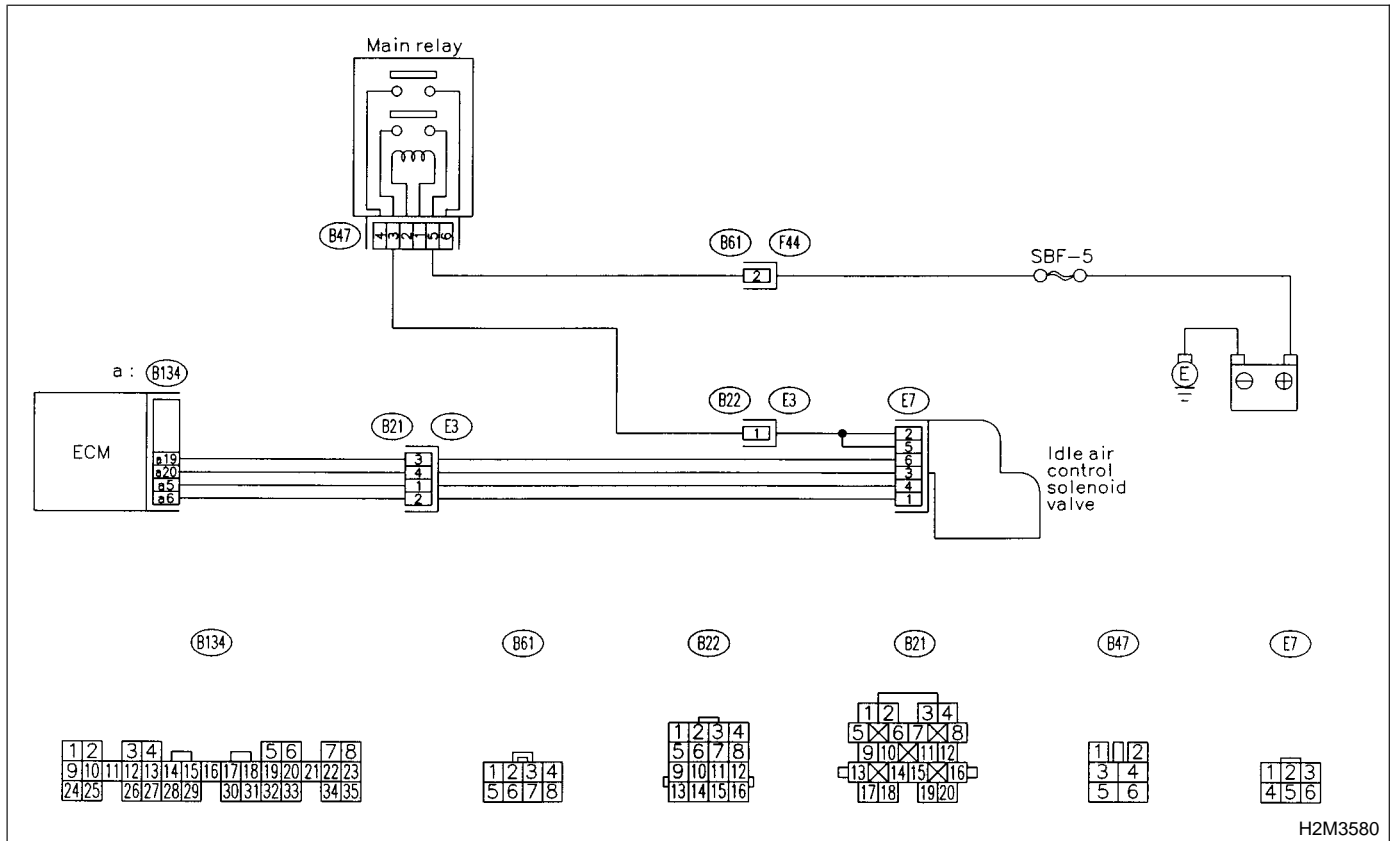

H2M3580

**10CV1 : CHECK ANY OTHER DTC ON DISPLAY.**

- CHECK** : Does the Subaru Select Monitor or OBD-II general scan tool indicate DTC P1511, P1513, P1515 and P1517 at same time?
- YES** : Go to step 10CV2.
- NO** : Go to step 10CV3.

**10CV2 : CHECK GROUND CIRCUIT FOR ECM.**

- 1) Turn ignition switch to OFF.
- 2) Measure resistance between ECM connector and chassis ground.

**Connector & terminal**

**(B134) No. 7 — Chassis ground:**

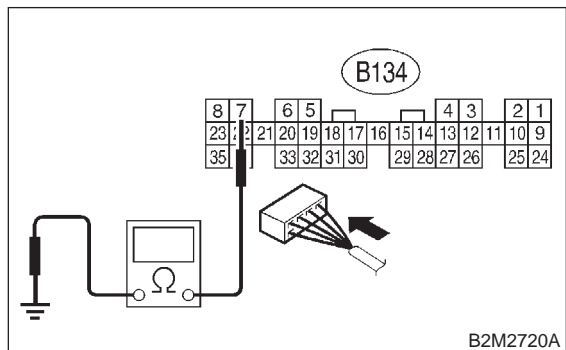

**CHECK** : *Is the resistance less than 5 Ω?*

**YES** : Go to step 10CV3.

**NO** : Repair harness and connector.

**NOTE:**

In this case, repair the following:

- Open circuit in harness between ECM connector and engine ground terminal
- Poor contact in ECM connector
- Poor contact in coupling connector (B22)

**10CV3 : CHECK HARNESS BETWEEN ECM AND IDLE AIR CONTROL SOLENOID VALVE CONNECTOR.**

- 1) Turn ignition switch to OFF.
- 2) Disconnect connector from idle air control solenoid valve.
- 3) Turn ignition switch to ON.
- 4) Measure voltage between ECM connector and chassis ground.

**Connector & terminal**

**DTC P1511; (B134) No. 5 (+) — Chassis**

**ground (-):**

**DTC P1513; (B134) No. 6 (+) — Chassis**

**ground (-):**

**DTC P1515; (B134) No. 19 (+) — Chassis**

**ground (-):**

**DTC P1517; (B134) No. 20 (+) — Chassis**

**ground (-):**

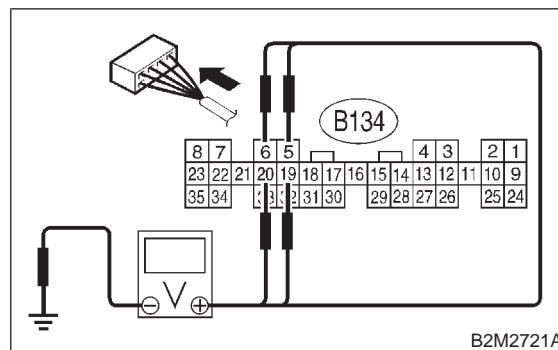

**CHECK** : *Is the voltage more than 10 V?*

**YES** : Repair battery short circuit in harness between ECM and idle air control solenoid valve connector. After repair, replace ECM. <Ref. to 2-7 [W17A0].>

**NO** : Replace ECM. <Ref. to 2-7 [W17A0].>

**CW: DTC P1520 — COOLING FAN RELAY 1 CIRCUIT HIGH INPUT —**

- **DTC DETECTING CONDITION:**
  - Two consecutive driving cycles with fault
- **TROUBLE SYMPTOM:**
  - Radiator fan does not operate properly.
  - Overheating

**CAUTION:**

After repair or replacement of faulty parts, conduct CLEAR MEMORY MODE <Ref. to 2-7 [T3D0].> and INSPECTION MODE <Ref. to 2-7 [T3E0].>

● **WIRING DIAGRAM:**

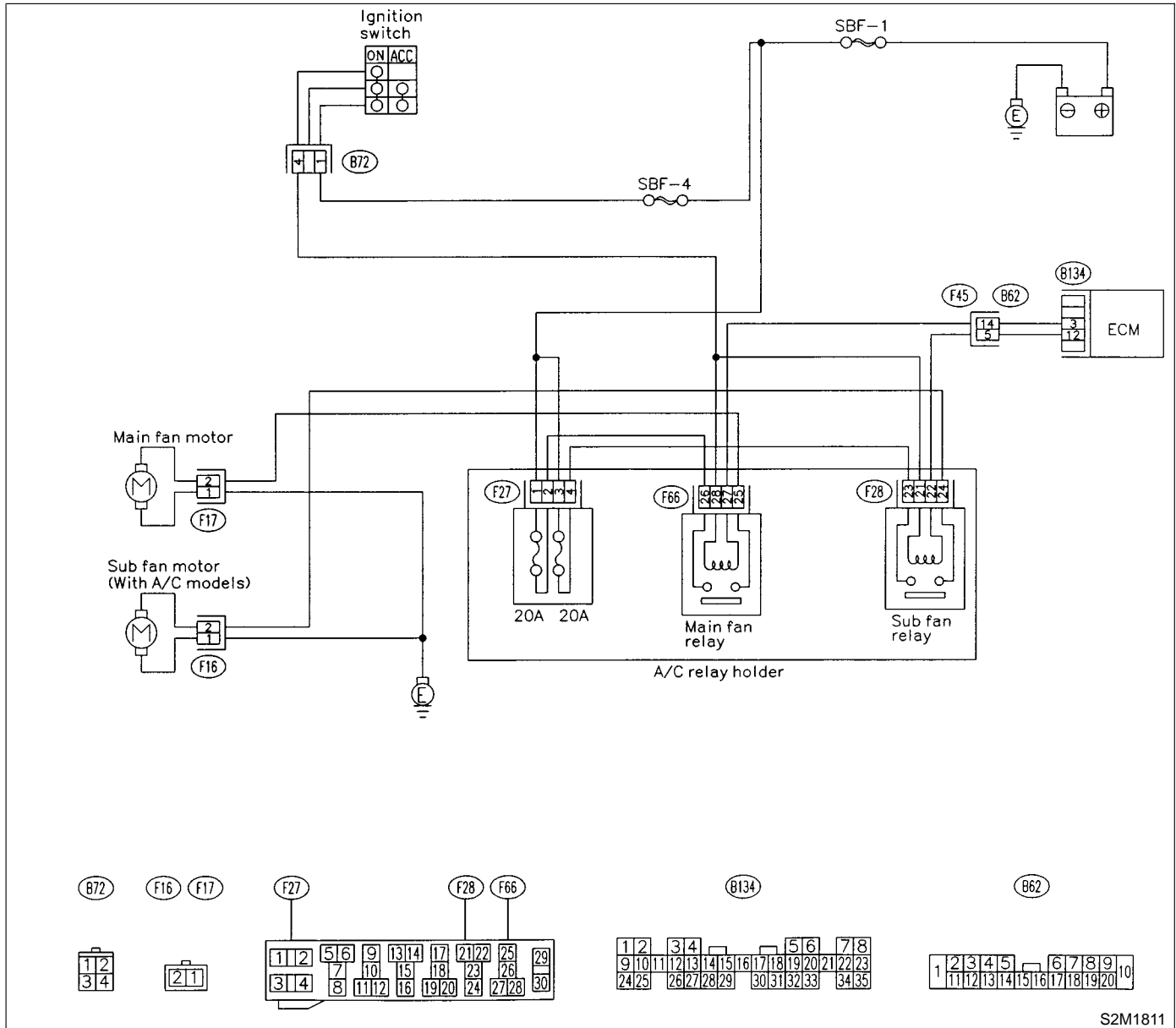

S2M1811

**10CW1 : CHECK OUTPUT SIGNAL FROM ECM.**

- 1) Turn ignition switch to OFF.
- 2) Connect test mode connector at the lower portion of instrument panel (on the driver's side), to the side of the center console box.

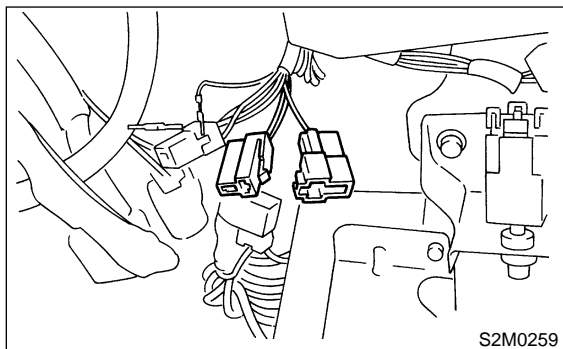

- 3) Turn ignition switch to ON.
- 4) While operating radiator fan relay, measure voltage between ECM and chassis ground.

**NOTE:**

Radiator fan relay operation can be executed using Subaru Select Monitor. For procedure, refer to "COMPULSORY VALVE OPERATION CHECK MODE". <Ref. to 2-7 [T3F0].>

**Connector & terminal**

**(B134) No. 3 (+) — Chassis ground (-):**

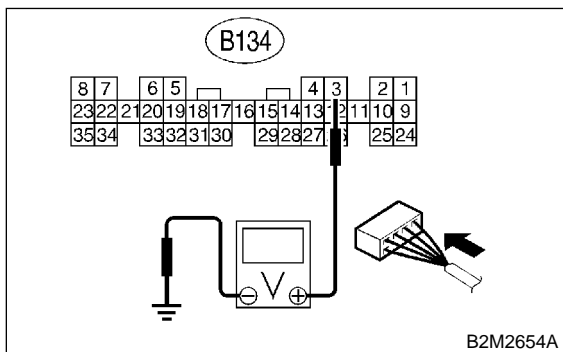

- CHECK** : Does voltage change between 0 and 10 V?
- YES** : Even if MIL lights up, the circuit has returned to a normal condition at this time. In this case, repair poor contact in ECM connector.
- NO** : Go to step **10CW2**.

**10CW2 : CHECK SHORT CIRCUIT IN RADIATOR FAN RELAY CONTROL CIRCUIT.**

- 1) Turn ignition switch to OFF.
- 2) Remove main fan relay and sub fan relay. (with A/C models)
- 3) Disconnect test mode connector.
- 4) Turn ignition switch to ON.
- 5) Measure voltage between ECM and chassis ground.

**Connector & terminal**

**(B134) No. 3 (+) — Chassis ground (-):**

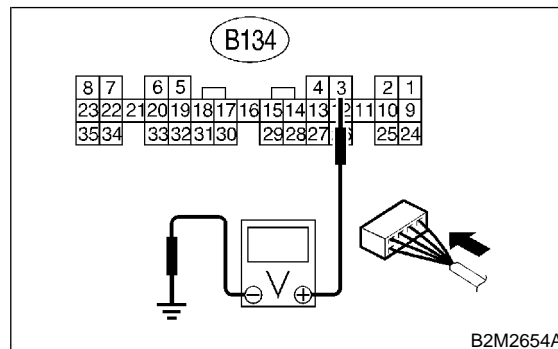

- CHECK** : Is the voltage more than 10 V?
- YES** : Repair battery short circuit in radiator fan relay control circuit. After repair, replace ECM. <Ref. to 2-7 [W17A0].>
- NO** : Go to step **10CW3**.

**10CW3 : CHECK MAIN FAN RELAY.**

- 1) Turn ignition switch to OFF.
- 2) Remove main fan relay.
- 3) Measure resistance between main fan relay terminals.

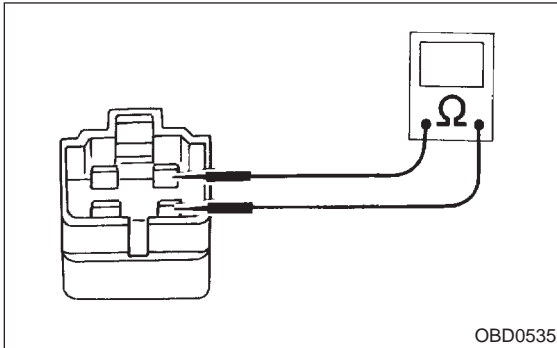
**Terminal****No. 1 — No. 3:**

- CHECK** : **Is the resistance less than 1 Ω?**
- YES** : Replace main fan relay and ECM <Ref. to 2-7 [W17A0].>
- NO** : Go to step **10CW4**.

**10CW4 : CHECK SUB FAN RELAY.**

- 1) Remove sub fan relay.
- 2) Measure resistance between sub fan relay terminals.

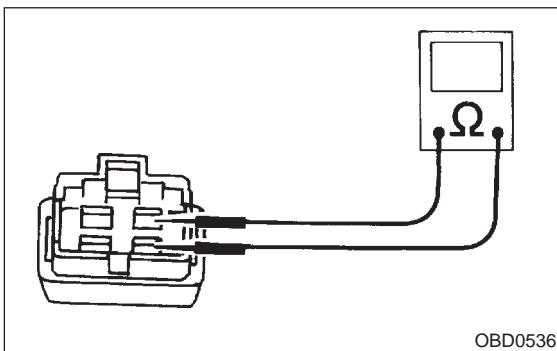
**Terminal****No. 1 — No. 3**

- CHECK** : **Is the resistance less than 1 Ω?**
- YES** : Replace sub fan relay and ECM <Ref. to 2-7 [W17A0].>
- NO** : Go to step **10CW5**.

**10CW5 : CHECK POOR CONTACT.**

Check poor contact in ECM connector. <Ref. to FOREWORD [T3C1].>

- CHECK** : **Is there poor contact in ECM connector?**
- YES** : Repair poor contact in ECM connector.
- NO** : Replace ECM. <Ref. to 2-7 [W17A0].>

**MEMO:**



**CX: DTC P1540 — VEHICLE SPEED SENSOR MALFUNCTION 2 —**

- **DTC DETECTING CONDITION:**
  - Immediately at fault recognition

**CAUTION:**

After repair or replacement of faulty parts, conduct **CLEAR MEMORY MODE** <Ref. to 2-7 [T3D0].> and **INSPECTION MODE** <Ref. to 2-7 [T3E0].>

● **WIRING DIAGRAM:**

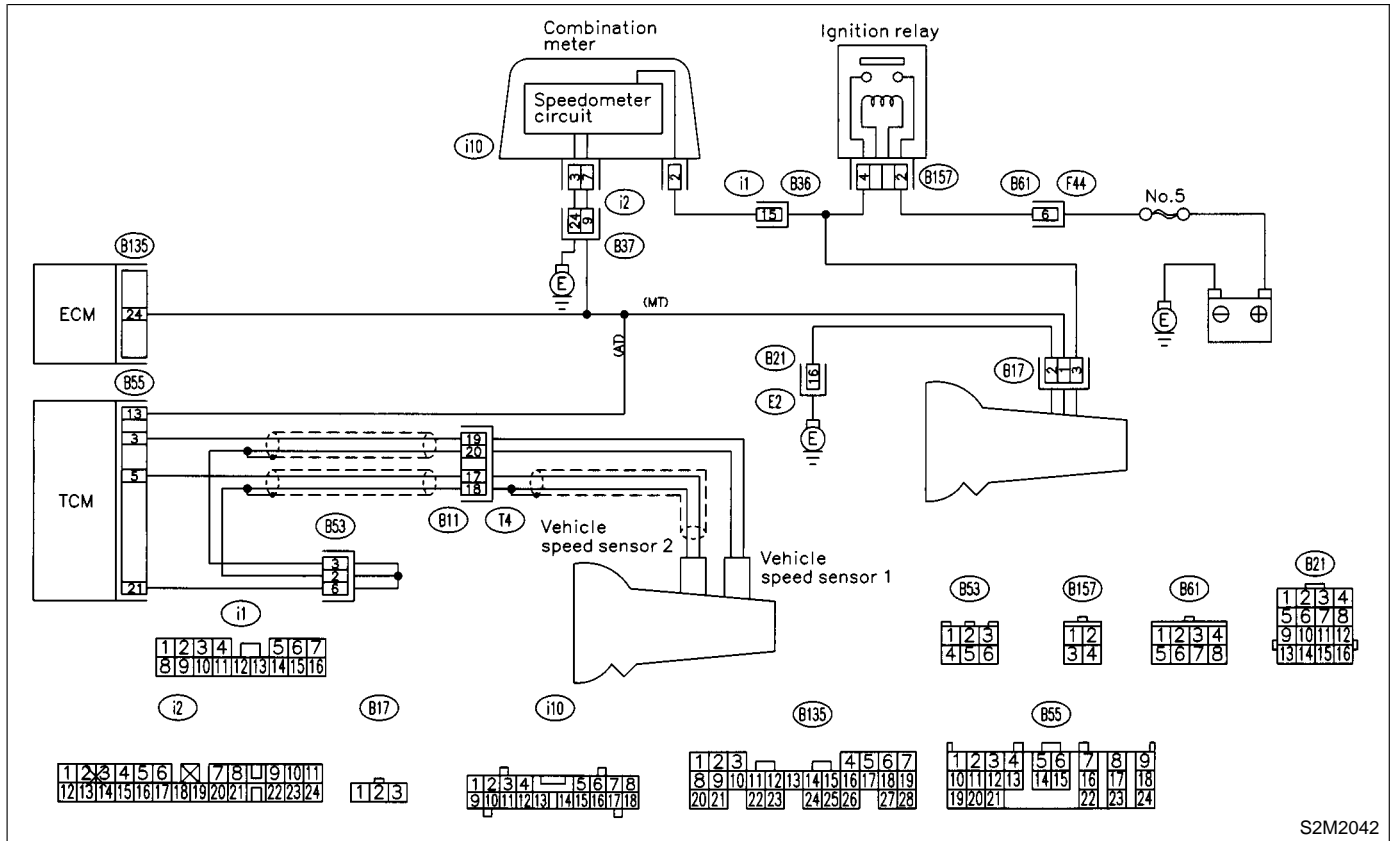

S2M2042

**10CX1 : CHECK TRANSMISSION TYPE.**

- CHECK** : *Is transmission type AT?*
- YES** : Go to step 10CX2.
- NO** : Go to step 10CX3.

**10CX2 : CHECK DTC P0720 ON DISPLAY.**

- CHECK** : *Does the Subaru Select Monitor or OBD-II general scan tool indicate DTC P0720?*
- YES** : Check vehicle speed sensor 2 signal circuit. <Ref. to 3-2 [T8F0].>
- NO** : Go to step 10CX3.

**10CX3 : CHECK SPEEDOMETER OPERATION IN COMBINATION METER.**

- CHECK** : *Does speedometer operate normally?*
- YES** : Go to step 10CX4.
- NO** : Check speedometer and vehicle speed sensor. <Ref. to 6-2 [T1A0].>

**10CX4 : CHECK HARNESS BETWEEN ECM AND COMBINATION METER CONNECTOR.**

- 1) Turn ignition switch to OFF.
- 2) Disconnect connector from combination meter.
- 3) Measure resistance between ECM and combination meter.

**Connector & terminal**

**(B135) No. 24 — (i10) No. 7:**

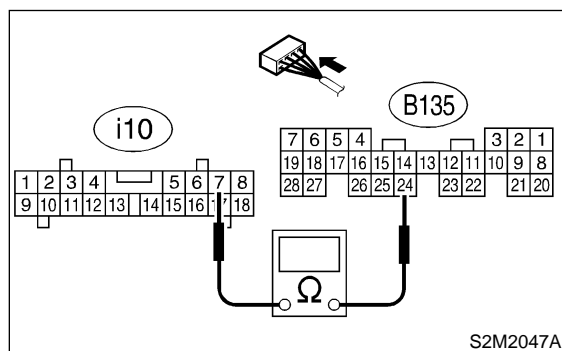

**CHECK** : **Is the resistance less than 10 Ω?**

**YES** : Repair poor contact in ECM connector.

**NO** : Repair harness and connector.

**NOTE:**

In this case, repair the following:

- Open circuit in harness between ECM and combination meter connector
- Poor contact in ECM connector
- Poor contact in combination meter connector
- Poor contact in coupling connector (i2)

**CY: DTC P1560 — BACK-UP VOLTAGE CIRCUIT MALFUNCTION —**

**● DTC DETECTING CONDITION:**

- Two consecutive driving cycles with fault

**CAUTION:**

After repair or replacement of faulty parts, conduct CLEAR MEMORY MODE <Ref. to 2-7 [T3D0].> and INSPECTION MODE <Ref. to 2-7 [T3E0].>

**● WIRING DIAGRAM:**

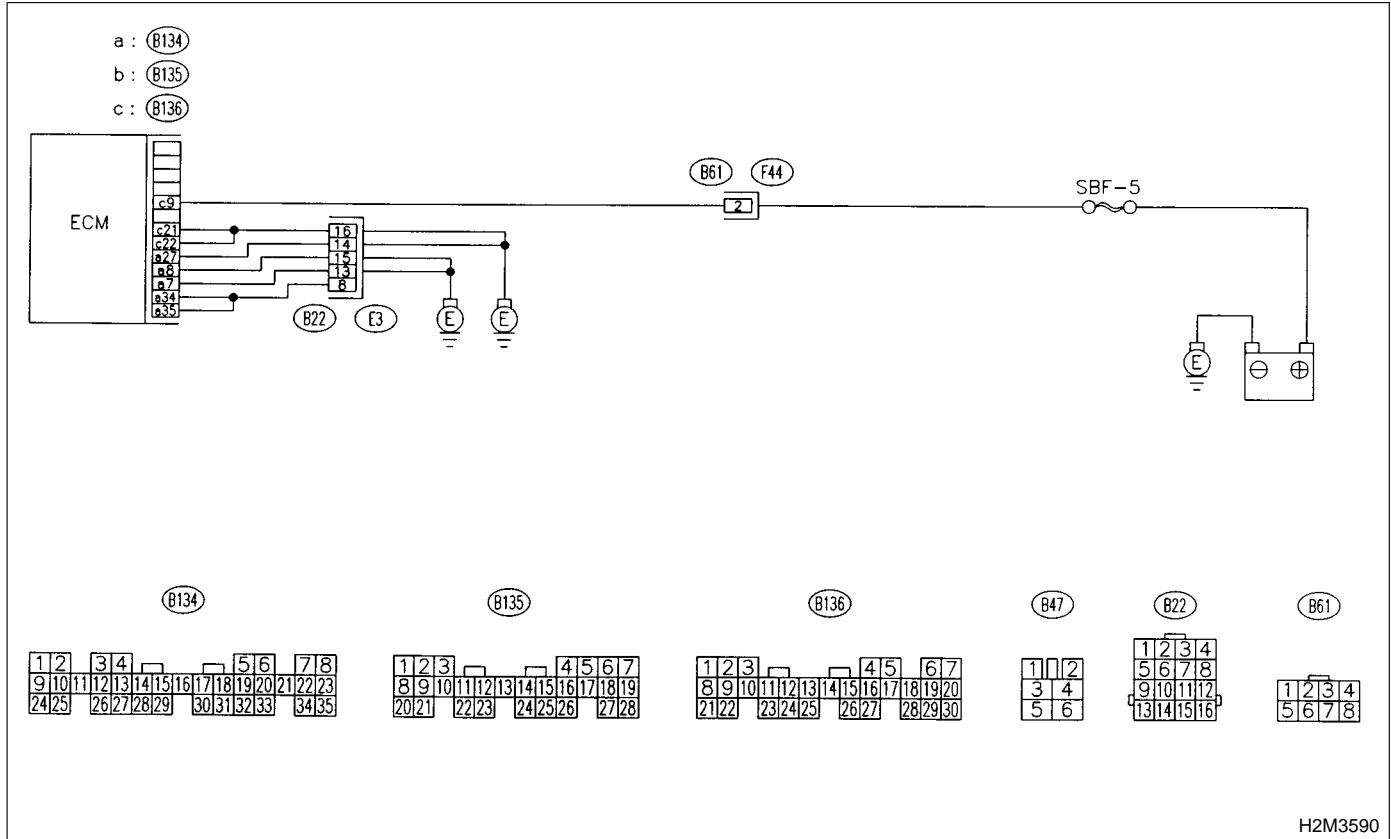

H2M3590

**10CY1 : CHECK INPUT SIGNAL FOR ECM.**

- 1) Turn ignition switch to OFF.
- 2) Measure voltage between ECM and chassis ground.

**Connector & terminal**

**(B136) No. 9 (+) — Chassis ground (-):**

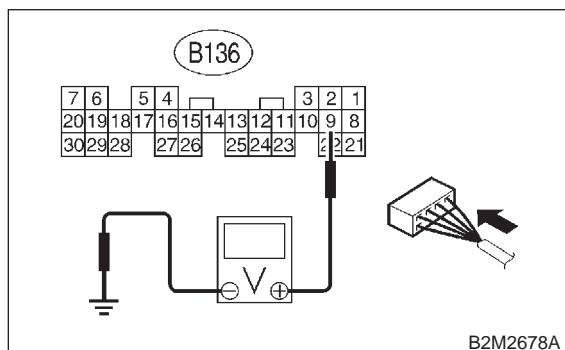

- CHECK** : **Is the voltage more than 10 V?**
- YES** : Repair poor contact in ECM connector.
- NO** : Go to step **10CY2**.

**10CY2 : CHECK HARNESS BETWEEN ECM AND MAIN FUSE BOX CONNECTOR.**

- 1) Disconnect connector from ECM.
- 2) Measure resistance of harness between ECM and chassis ground.

**Connector & terminal**

**(B136) No. 9 — Chassis ground:**

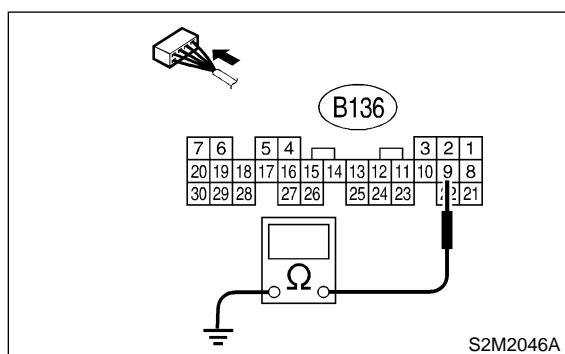

- CHECK** : **Is the resistance less than 10 Ω?**
- YES** : Repair ground short circuit in harness between ECM connector and battery terminal.
- NO** : Go to step **10CY3**.

**10CY3 : CHECK FUSE SBF-5.**

- CHECK** : **Is fuse blown?**
- YES** : Replace fuse. <Ref. to 6-3 [D6A0].>
- NO** : Repair harness and connector.

**NOTE:**

In this case, repair the following:

- Open circuit in harness between ECM and battery
- Poor contact in ECM connector
- Poor contact in battery terminal

**CZ: DTC P1700 — THROTTLE POSITION SENSOR CIRCUIT MALFUNCTION FOR AUTOMATIC TRANSMISSION —****● DTC DETECTING CONDITION:**

- Two consecutive driving cycles with fault

**● TROUBLE SYMPTOM:**

- Shift point too high or too low; engine brake not effected in “3” range; excessive shift shock; excessive tight corner “braking”

**CAUTION:**

After repair or replacement of faulty parts, conduct CLEAR MEMORY MODE <Ref. to 2-7 [T3D0].> and INSPECTION MODE <Ref. to 2-7 [T3E0].>.

**NOTE:**

Check throttle position sensor circuit. <Ref. to 3-2 [T8F0].>

**MEMO:**

**DA: DTC P1701 — CRUISE CONTROL SET SIGNAL CIRCUIT MALFUNCTION FOR AUTOMATIC TRANSMISSION —**

**● DTC DETECTING CONDITION:**

- Two consecutive driving cycles with fault

**CAUTION:**

After repair or replacement of faulty parts, conduct CLEAR MEMORY MODE <Ref. to 2-7 [T3D0].> and INSPECTION MODE <Ref. to 2-7 [T3E0].>

**● WIRING DIAGRAM:**

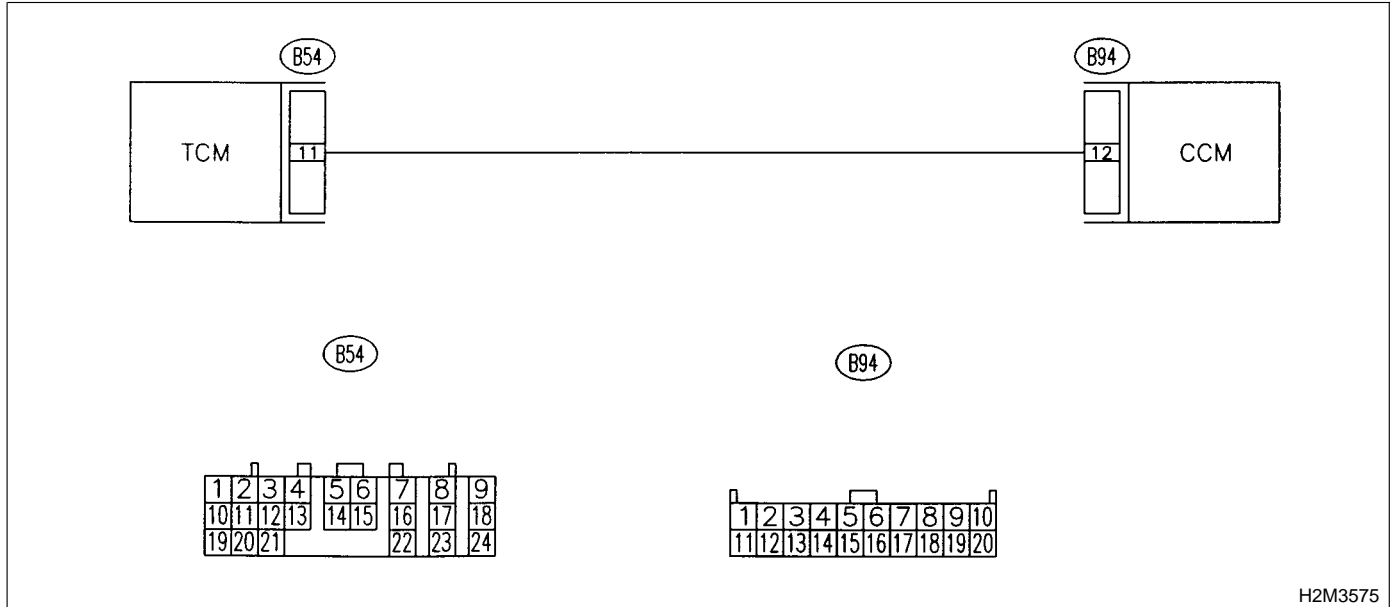

H2M3575

**10DA1 : CHECK HARNESS BETWEEN TCM AND CCM CONNECTOR.**

**10DA2 : CHECK HARNESS BETWEEN TCM AND CCM CONNECTOR.**

- 1) Turn ignition switch to OFF.
- 2) Disconnect connectors from TCM and CCM.
- 3) Measure resistance of harness between TCM and CCM connector.

Measure resistance of harness between TCM and chassis ground.

**Connector & terminal**  
**(B54) No. 11 — Chassis ground:**

**Connector & terminal**  
**(B54) No. 11 — (B94) No. 12:**

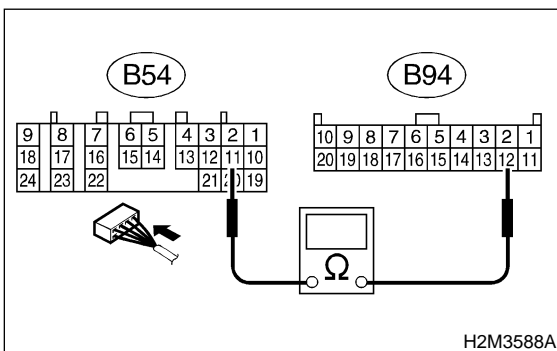

H2M3588A

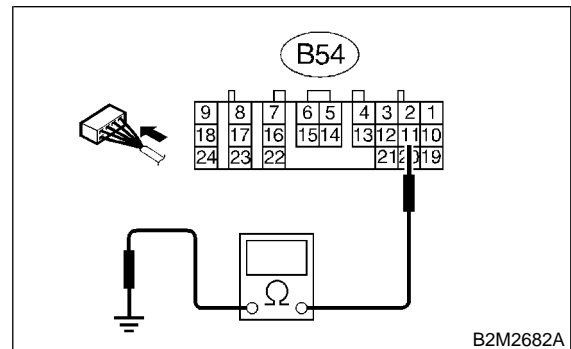

B2M2682A

- CHECK** : Is the resistance less than 1 Ω?
- YES** : Go to step 10DA2.
- NO** : Repair open circuit in harness between TCM and CCM connector.

- CHECK** : Is the resistance less than 10 Ω?
- YES** : Repair short circuit in harness between TCM and CCM connector.
- NO** : Go to step 10DA3.

**10DA3 : CHECK INPUT SIGNAL FOR TCM.**

- 1) Connect connector to TCM and CCM.
- 2) Lift-up the vehicle or set the vehicle on free rollers.

**CAUTION:**

**On AWD models, raise all wheels off ground.**

- 3) Start the engine.
- 4) Cruise control main switch to ON.
- 5) Move select lever to "D" and slowly increase vehicle speed to 50 km/h (31 MPH).
- 6) Cruise control set switch to ON.
- 7) Measure voltage between TCM and chassis ground.

**Connector & terminal**

**(B54) No. 11 (+) — Chassis ground (-):**

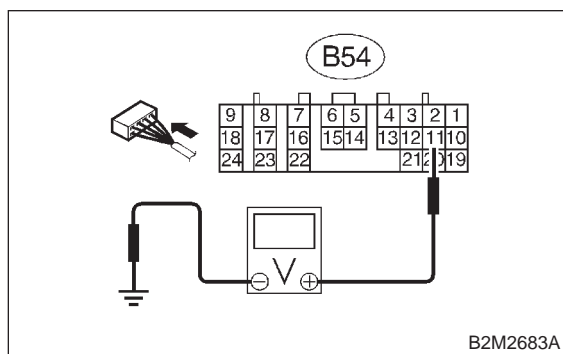

- CHECK** : **Is the resistance less than 1 V?**
- YES** : Go to step **10DA4**.
- NO** : Check cruise control set circuit. <Ref. to 6-2 [T7A0].>

**10DA4 : CHECK POOR CONTACT.**

Check poor contact in TCM connector. <Ref. to FOREWORD [T3C1].>

- CHECK** : **Is there poor contact in TCM connector?**
- YES** : Repair poor contact in TCM connector.
- NO** : Replace TCM. <Ref. to 3-2 [W23A0].>



**DB: DTC P1702 — AUTOMATIC TRANSMISSION DIAGNOSIS INPUT SIGNAL CIRCUIT LOW INPUT —**

- **DTC DETECTING CONDITION:**
  - Two consecutive driving cycles with fault

**CAUTION:**

After repair or replacement of faulty parts, conduct CLEAR MEMORY MODE <Ref. to 2-7 [T3D0].> and INSPECTION MODE <Ref. to 2-7 [T3E0].>

● **WIRING DIAGRAM:**

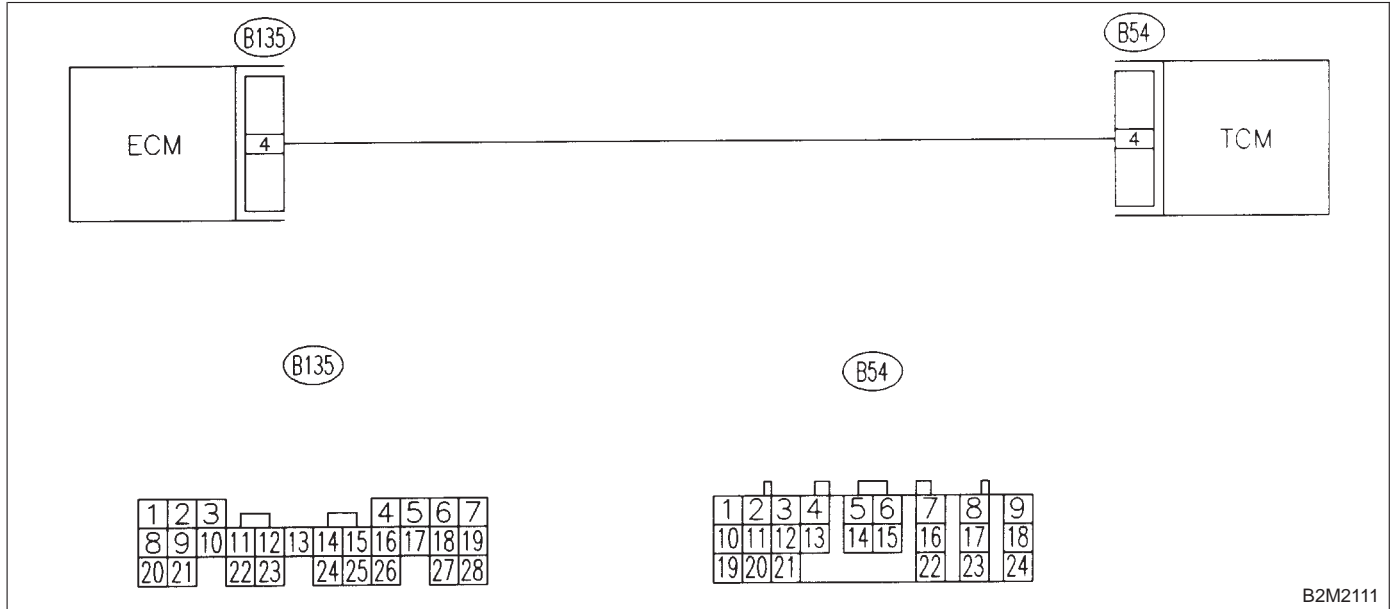

B2M2111

**10DB1 : CHECK TRANSMISSION TYPE.**

- CHECK** : *Is transmission type AT?*
- YES** : Go to step **10DB2**.
- NO** : Check AT/MT identification circuit. <Ref. to 2-7 [T10DH0].>

**10DB2 : CHECK HARNESS BETWEEN ECM AND TCM CONNECTOR.**

- 1) Turn ignition switch to ON.
- 2) Measure voltage between ECM and chassis ground.

**Connector & terminal**

**(B135) No. 4 (+) — Chassis ground (-):**

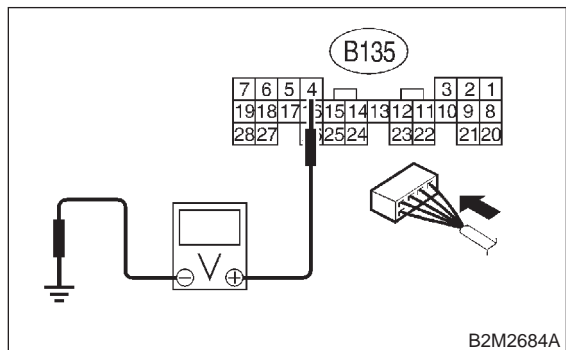

- CHECK** : *Is the voltage less than 1 V?*
- YES** : Go to step **10DB3**.
- NO** : Even if MIL lights up, the circuit has returned to a normal condition at this time.

**NOTE:**

- In this case, repair the following:
- Poor contact in ECM connector
  - Poor contact in TCM connector

**10DB3 : CHECK HARNESS BETWEEN ECM AND TCM CONNECTOR.**

- 1) Turn ignition switch to OFF.
- 2) Disconnect connector from ECM and TCM.
- 3) Measure resistance of harness between ECM and chassis ground.

**Connector & terminal**

**(B135) No. 4 — Chassis ground:**

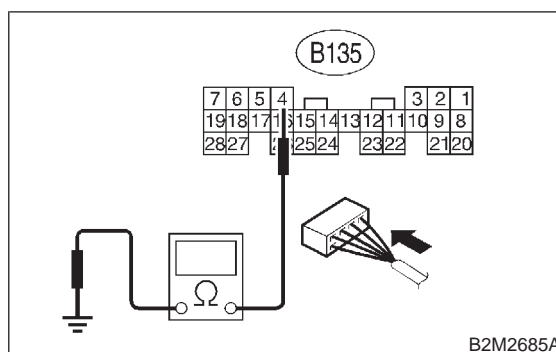

- CHECK** : *Is the resistance less than 10 Ω?*
- YES** : Repair ground short circuit in harness between ECM and TCM connector.
- NO** : Go to step **10DB4**.

**10DB4 : CHECK OUTPUT SIGNAL FOR ECM.**

- 1) Connect connector to ECM.
- 2) Turn ignition switch to ON.
- 3) Measure voltage between ECM and chassis ground.

**Connector & terminal**

**(B135) No. 4 (+) — Chassis ground (-):**

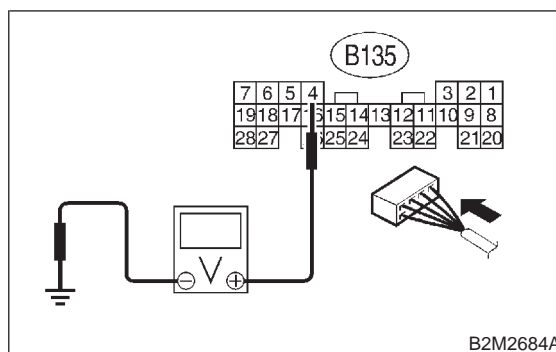

- CHECK** : *Is the voltage more than 5 V?*
- YES** : Go to step **10DB5**.
- NO** : Repair poor contact in ECM connector.

**10DB5 : CHECK TROUBLE CODE FOR  
AUTOMATIC TRANSMISSION.**

Read trouble code for automatic transmission.  
<Ref. to 3-2 [T8A0].>

- CHECK** : *Does trouble code appear for automatic transmission?*
- YES** : Inspect trouble code for automatic transmission. <Ref. to 3-2 [T8A0].>
- NO** : Replace TCM. <Ref. to 3-2 [W23A0].>

**DC: DTC P1703 — LOW CLUTCH TIMING CONTROL SOLENOID VALVE CIRCUIT MALFUNCTION —****● DTC DETECTING CONDITION:**

- Two consecutive driving cycles with fault

**CAUTION:**

After repair or replacement of faulty parts, conduct CLEAR MEMORY MODE <Ref. to 2-7 [T3D0].> and INSPECTION MODE <Ref. to 2-7 [T3E0].>.

**NOTE:**

Check low clutch timing control solenoid valve circuit. <Ref. to 3-2 [T8L0].>

**DD: DTC P1704 — 2-4 BRAKE TIMING CONTROL SOLENOID VALVE CIRCUIT MALFUNCTION —****● DTC DETECTING CONDITION:**

- Two consecutive driving cycles with fault

**CAUTION:**

After repair or replacement of faulty parts, conduct CLEAR MEMORY MODE <Ref. to 2-7 [T3D0].> and INSPECTION MODE <Ref. to 2-7 [T3E0].>.

**NOTE:**

Check 2-4 brake timing control solenoid valve circuit. <Ref. to 3-2 [T8M0].>

**DE: DTC P1705 — 2-4 BRAKE PRESSURE CONTROL SOLENOID VALVE (2-4 BRAKE DUTY SOLENOID) CIRCUIT MALFUNCTION —****● DTC DETECTING CONDITION:**

- Two consecutive driving cycles with fault

**CAUTION:**

After repair or replacement of faulty parts, conduct CLEAR MEMORY MODE <Ref. to 2-7 [T3D0].> and INSPECTION MODE <Ref. to 2-7 [T3E0].>.

**NOTE:**

Check 2-4 brake duty solenoid circuit. <Ref. to 3-2 [T8O0].>

**DF: DTC P1722 — AUTOMATIC TRANSMISSION DIAGNOSIS INPUT SIGNAL CIRCUIT HIGH INPUT —**

- **DTC DETECTING CONDITION:**
  - Two consecutive driving cycles with fault

**CAUTION:**

After repair or replacement of faulty parts, conduct CLEAR MEMORY MODE <Ref. to 2-7 [T3D0].> and INSPECTION MODE <Ref. to 2-7 [T3E0].>

● **WIRING DIAGRAM:**

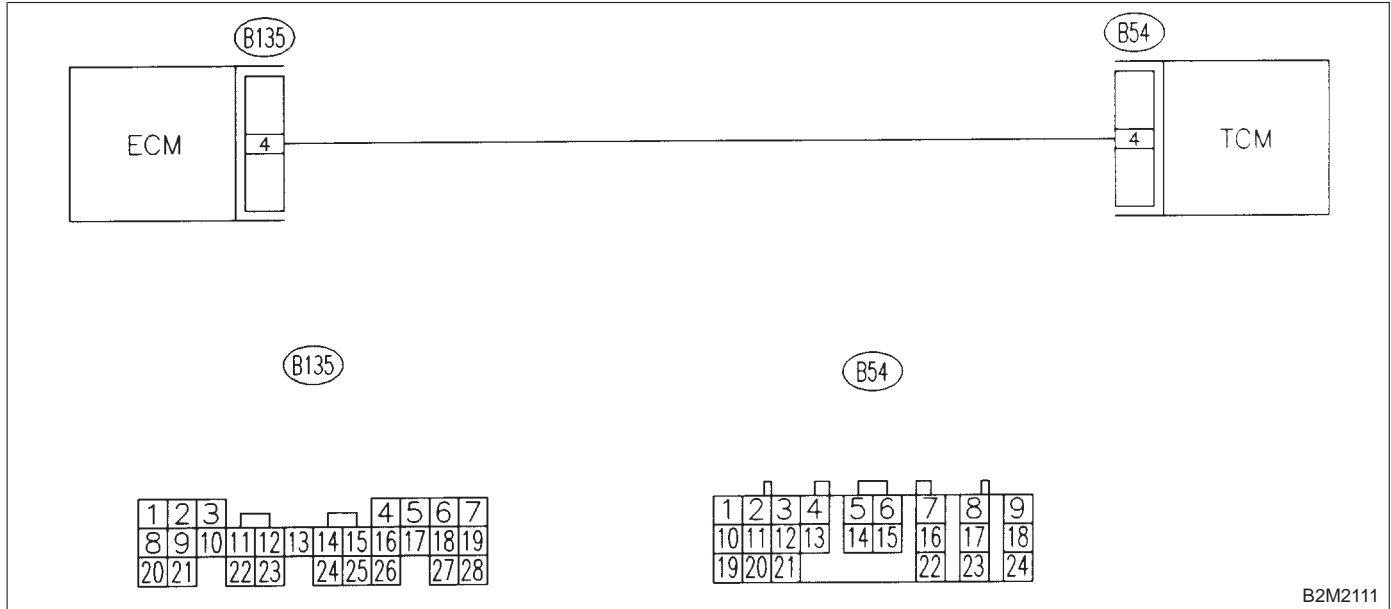

B2M2111

**10DF1 : CHECK TRANSMISSION TYPE.**

- CHECK** : *Is transmission type AT?*
- YES** : Go to step **10DF2**.
- NO** : Check AT/MT identification circuit. <Ref. to [T10DH0].>

**10DF2 : CHECK HARNESS BETWEEN ECM AND TCM CONNECTOR.**

- 1) Turn ignition switch to ON.
- 2) Measure voltage between ECM and chassis ground.

**Connector & terminal**

**(B135) No. 4 (+) — Chassis ground (-):**

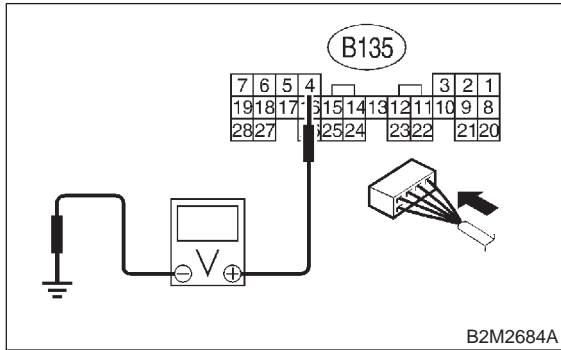

- CHECK** : **Is the voltage more than 10 V?**
- YES** : Repair battery short circuit in harness between ECM and TCM connector. After repair, replace ECM. <Ref. to 2-7 [W17A0].>
- NO** : Go to step **10DF3**.

**10DF3 : CHECK HARNESS BETWEEN ECM AND TCM CONNECTOR.**

Measure voltage between ECM connector and chassis ground.

**Connector & terminal**

**(B135) No. 4 (+) — Chassis ground (-):**

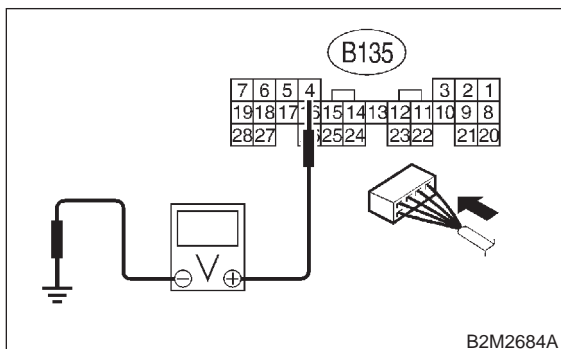

- CHECK** : **Is the voltage more than 4 V?**
- YES** : Go to step **10DF6**.
- NO** : Go to step **10DF4**.

**10DF4 : CHECK HARNESS BETWEEN ECM AND TCM CONNECTOR.**

Measure voltage between ECM connector and chassis ground.

**Connector & terminal**

**(B135) No. 4 (+) — Chassis ground (-):**

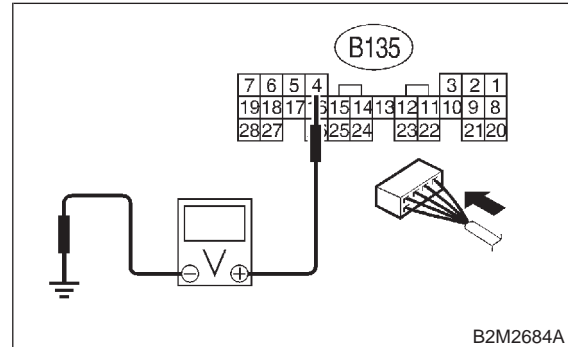

- CHECK** : **Is the voltage less than 1 V?**
- YES** : Repair poor contact in ECM connector.
- NO** : Go to step **10DF5**.



## DG: DTC P1742 — AUTOMATIC TRANSMISSION DIAGNOSIS INPUT SIGNAL CIRCUIT MALFUNCTION —

● **DTC DETECTING CONDITION:**

- Two consecutive driving cycles with fault

**CAUTION:**

After repair or replacement of faulty parts, conduct CLEAR MEMORY MODE <Ref. to 2-7 [T3D0].> and INSPECTION MODE <Ref. to 2-7 [T3E0].>

● **WIRING DIAGRAM:**

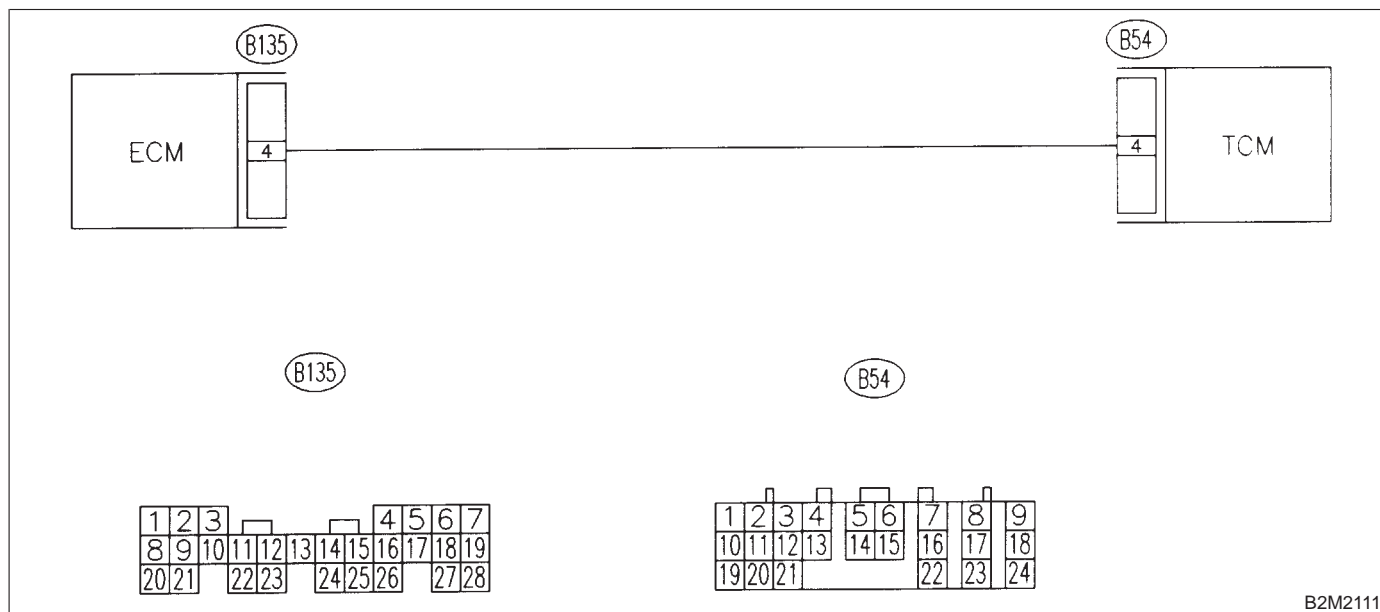

**10DG1 : CHECK TRANSMISSION TYPE.**

- CHECK** : *Is transmission type AT?*
- YES** : Go to step **10DG2**.
- NO** : Check AT/MT identification circuit. <Ref. to 2-7 [T10DH0].>

**10DG2 : CHECK DRIVING CONDITION.**

- 1) Start and warm-up the engine until the radiator fan makes one complete rotation.
- 2) Drive the vehicle.

- CHECK** : *Is AT shift control functioning properly?*
- YES** : Go to step **10DG3**.
- NO** : Replace TCM. <Ref. to 3-2 [W23A0].>

**10DG3 : CHECK ACCESSORY.**

- CHECK** : *Are car phone and/or CB installed on vehicle?*
- YES** : Repair grounding line of car phone or CB system.
- NO** : Replace TCM. <Ref. to 3-2 [W23A0].>



**DH: — AT/MT IDENTIFICATION CIRCUIT MALFUNCTION [MT VEHICLES] —**

**CAUTION:**

After repair or replacement of faulty parts, conduct CLEAR MEMORY MODE <Ref. to 2-7 [T3D0].> and INSPECTION MODE <Ref. to 2-7 [T3E0].>.

● **WIRING DIAGRAM:**

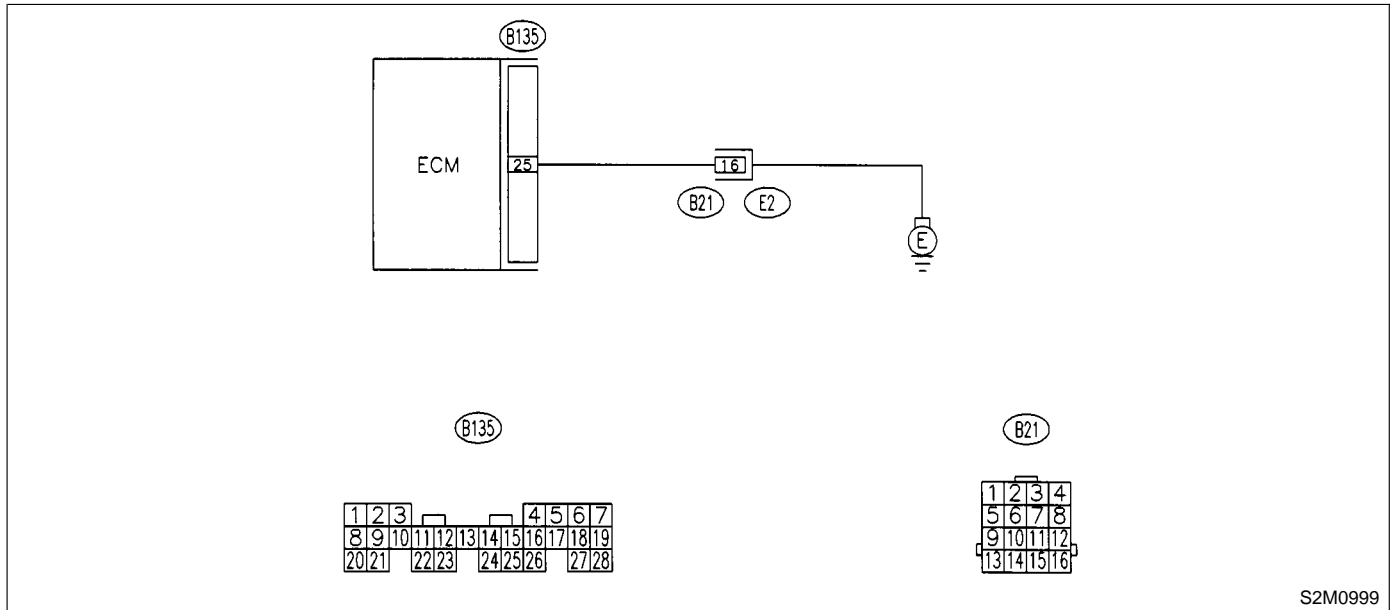

S2M0999

**10DH1 : CHECK HARNESS BETWEEN ECM CONNECTOR AND ENGINE GROUNDING TERMINAL.**

- 1) Turn ignition switch to ON.
- 2) Measure voltage between ECM and chassis ground.

**Connector & terminal**

**(B135) No. 25 (+) — Chassis ground (-):**

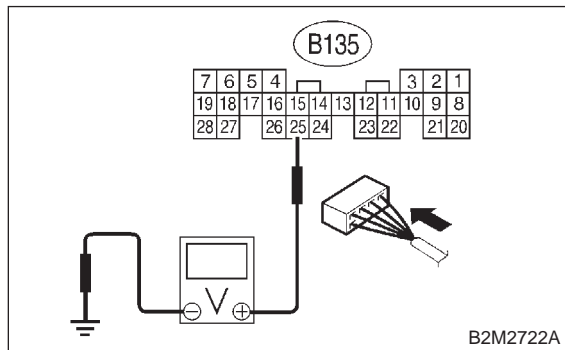

- CHECK** : *Is the voltage more than 2 V?*
- YES** : Repair harness and connector.

**NOTE:**

In this case, repair the following:

- Open circuit in harness between ECM connector and engine grounding terminal
- Poor contact in engine grounding terminal
- Poor contact in coupling connector (B21)

- NO** : Go to step **10DH2**.

**10DH2 : CHECK POOR CONTACT.**

Check poor contact in ECM connector. <Ref. to FOREWORD [W3C1].>

- CHECK** : *Is there poor contact in ECM connector?*
- YES** : Repair poor contact in ECM connector.
- NO** : Contact with SOA service.

**NOTE:**

Inspection by DTM is required, because probable cause is deterioration of multiple parts.

MEMO: