

1-5 [G6A1] PERIODIC MAINTENANCE SERVICES

6. Replace Engine Coolant and Inspect Cooling System, Hoses and Connections

6. Replace Engine Coolant and Inspect Cooling System, Hoses and Connections

MAINTENANCE INTERVAL																	
[Number of months or km (miles), whichever occurs first]																	
Months	3	7.5	15	22.5	30	37.5	45	52.5	60	67.5	75	82.5	90	97.5	105	112.5	120
× 1,000 km	4.8	12	24	36	48	60	72	84	96	108	120	132	144	156	168	180	192
× 1,000 miles	3	7.5	15	22.5	30	37.5	45	52.5	60	67.5	75	82.5	90	97.5	105	112.5	120
					P				P				P				P

A: REPLACEMENT

1. REPLACEMENT OF COOLANT

WARNING:

The radiator is of the pressurized type. Do not attempt to open the radiator cap immediately after the engine has been stopped.

- 1) Lift up the vehicle.
- 2) Remove undercover.
- 3) Fit vinyle tube to drain pipe.

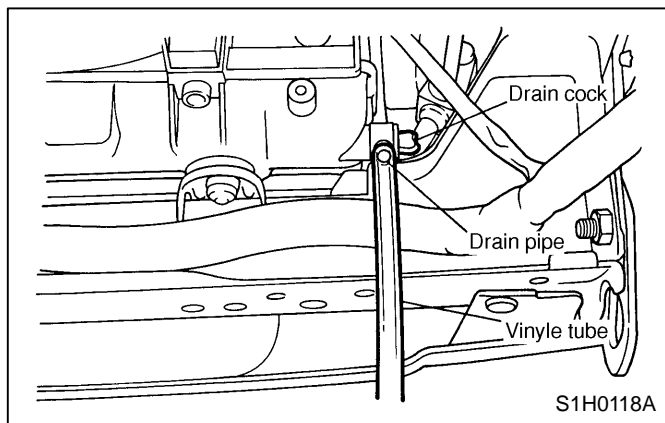

- 4) Place a container under vinyle tube.
- 5) Loosen drain cock to drain engine coolant into container.
- 6) For quick draining, open radiator cap.

CAUTION:

Be careful not to spill coolant on the floor.

- 7) Drain coolant from reservoir tank.
- 8) Tighten radiator drain plug securely after draining coolant. (Drain tube may face downward.)

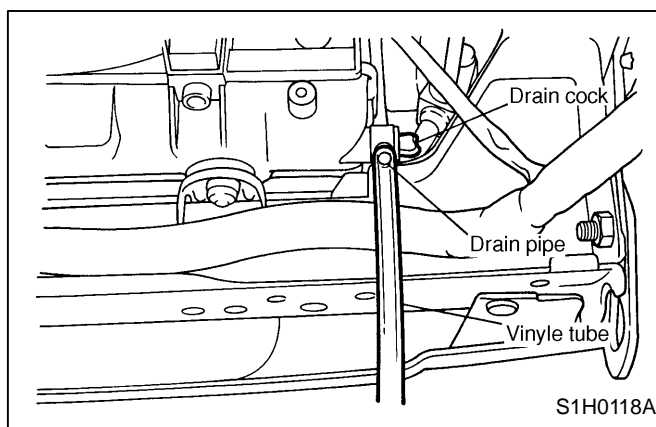

- 9) Fill engine coolant into radiator up to filler neck position.
- 10) Fill engine coolant into reservoir tank up to "FULL" level.

Coolant capacity (fill up to "FULL" level)
Approx. 6.0 ℓ (6.3 US qt, 5.3 Imp qt)

CAUTION:

The SUBARU Genuine Coolant containing anti-freeze and anti-rust agents is especially made for SUBARU engine, which has an aluminum crankcase. Always use SUBARU Genuine Coolant, since other coolant may cause corrosion.

- 11) Securely install radiator cap and reservoir tank cap.
- 12) Run engine for more than five minutes at 2,000 to 3,000 rpm. (Run engine until radiator becomes hot in order to purge air trapped in cooling system.)
- 13) Stop engine and wait until coolant temperature lowers. Then open radiator cap to check coolant level and add coolant up to radiator fill-

PERIODIC MAINTENANCE SERVICES

[G6A3] 1-5

6. Replace Engine Coolant and Inspect Cooling System, Hoses and Connections

er neck. Next, add coolant into reservoir tank up to "FULL" level.

14) Securely install radiator and reservoir tank caps.

2. RELATIONSHIP OF SUBARU COOLANT CONCENTRATION AND FREEZING TEMPERATURE

The concentration and safe operating temperature of the SUBARU coolant is shown in the diagram. Measuring the temperature and specific gravity of the coolant will provide this information.

[Example]

If the coolant temperature is 25°C (77°F) and its specific gravity is 1.054, the concentration is 35% (point A), the safe operating temperature is -14°C (7°F) (point B), and the freezing temperature is -20°C (-4°F) (point C).

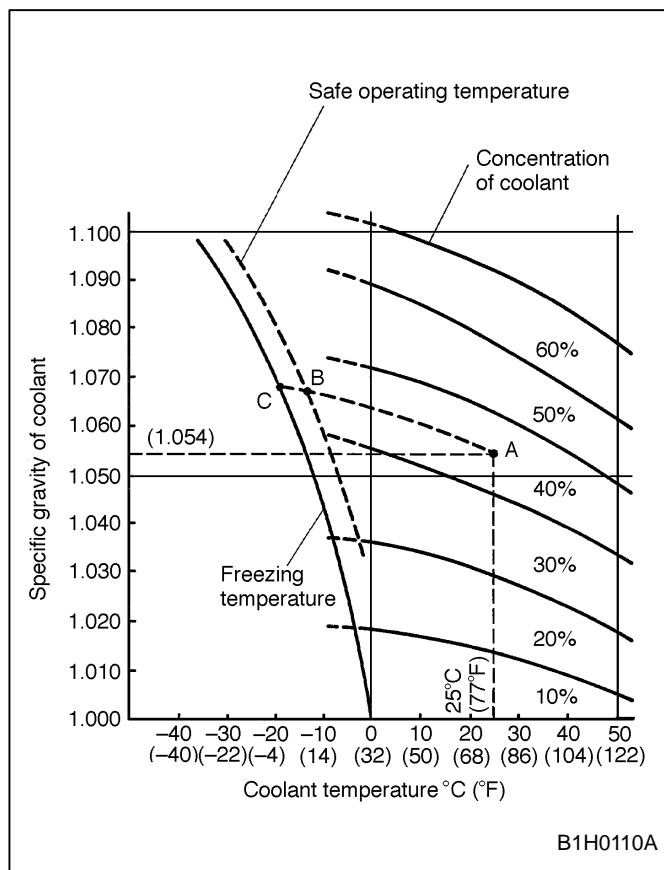

3. PROCEDURE TO ADJUST THE CONCENTRATION OF THE COOLANT

To adjust the concentration of the coolant according to temperature, find the proper fluid concentration in the above diagram and replace the necessary amount of coolant with an undiluted solution of SUBARU genuine coolant (concentration 50).

The amount of coolant that should be replaced can be determined using the diagram.

[Example]

Assume that the coolant concentration must be increased from 25% to 40%. Find point A, where the 25% line of coolant concentration intersects with the 40% curve of the necessary coolant concentration, and read the scale on the vertical axis of the graph at height A. The quantity of coolant to be drained is 2.1 liters (2.2 US qt, 1.8 Imp qt). Drain 2.1 liters (2.2 US qt, 1.8 Imp qt) of coolant from the cooling system and add 2.1 liters (2.2 US qt, 1.8 Imp qt) of the undiluted solution of SUBARU coolant.

If a coolant concentration of 50% is needed, drain all the coolant and refill with the undiluted solution only.

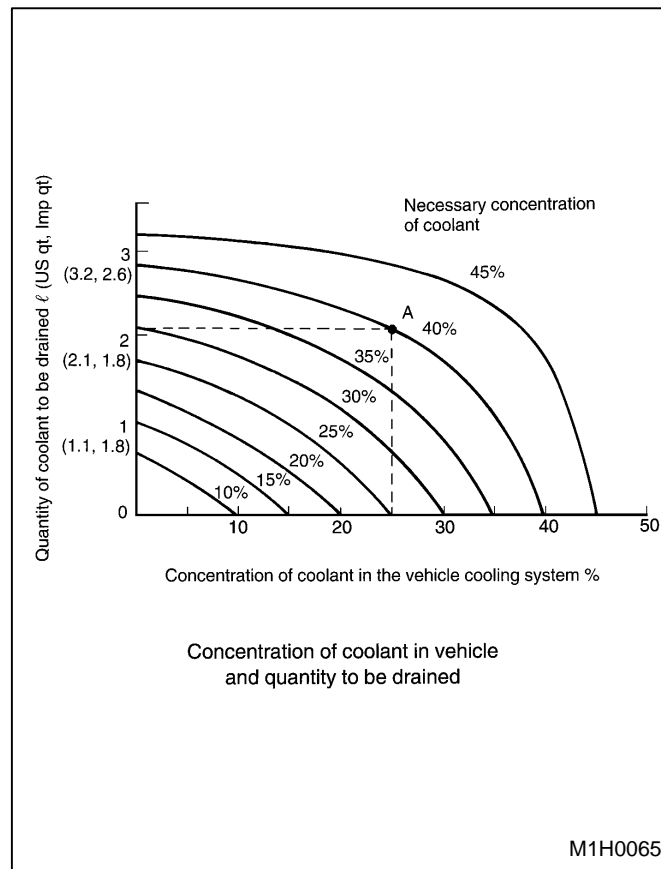

1-5 [G6B0] PERIODIC MAINTENANCE SERVICES

6. Replace Engine Coolant and Inspect Cooling System, Hoses and Connections

B: INSPECTION

1) Check radiator for leakage, filling it with coolant and attach radiator cap tester to the filler neck. Then apply a pressure of 157 kPa (1.6 kg/cm², 23 psi) and check the following points:

- Each portion of radiator for leakage
- Hose joints and other connections for leakage

CAUTION:

When attaching or detaching tester and when operating tester, use special care not to deform radiator filler neck.

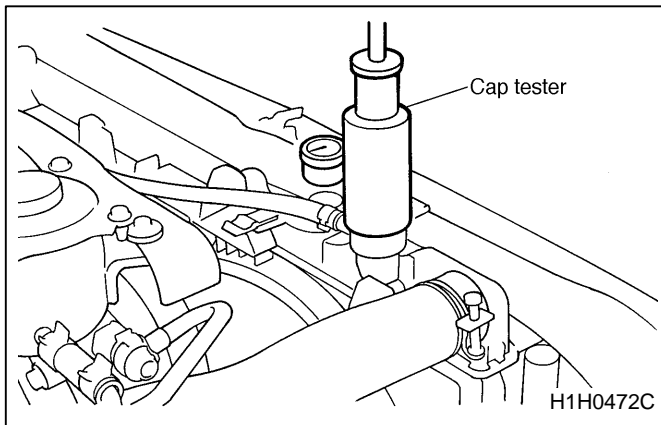

NOTE:

- When performing this check, be sure to keep the engine stationary and fill radiator with coolant.
- Wipe off check points before applying pressure.
- Use care not to spill coolant when detaching tester from radiator.

2) Check the radiator cap valve open pressure using radiator cap tester.

CAUTION:

Rust or dirt on cap may prevent valve from functioning normally: be sure to clean cap before testing.

Raise the pressure until the needle of gauge stops and see if the pressure can be retained for five to six seconds. The radiator cap is normal if a pressure above the service limit value has been maintained for this period.

Radiator cap valve open pressure

Standard value:

93 — 123 kPa

(0.95 — 1.25 kg/cm², 14 — 18 psi)

Service limit:

83 kPa (0.85 kg/cm², 12 psi)

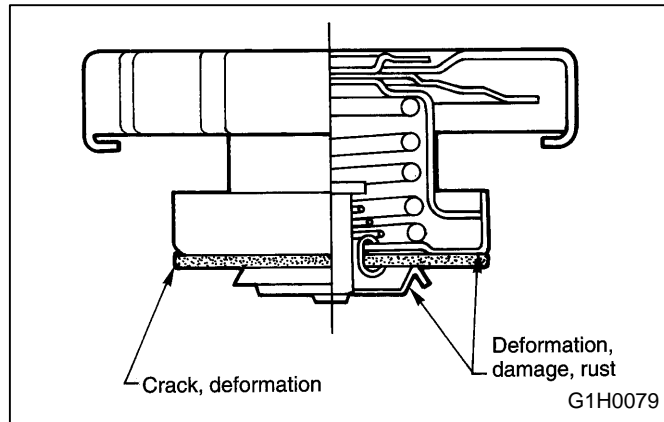
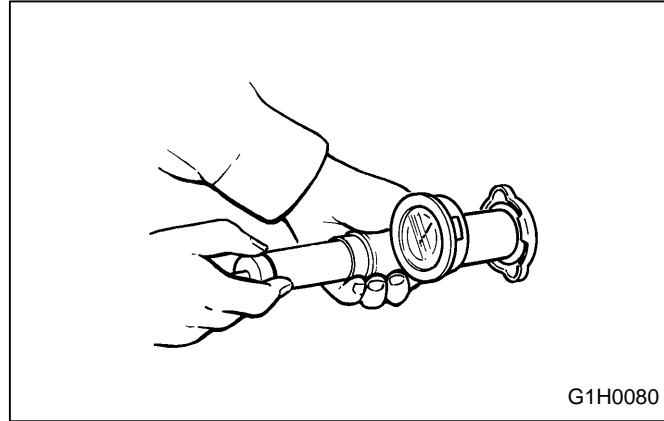

3) If the coolant temperature exceeds 76.0 to 80.0°C (169 to 176°F) while radiator is not so hot, check thermostat. If thermostat does not open at 76.0 to 80.0°C (169 to 176°F), replace it with a new one.

4) If electric fan does not operate when coolant temperature exceeds 90 to 94°C (194 to 201°F), check thermostwitch or fan motor.