

### 3. Road Test Inspection

#### A: TEST MODE CONNECTOR

##### CHECK POINTS

1. *Check engine light flashing*
2. *Test mode connector disconnection*

##### 1. CHECK THE MIL (CHECK ENGINE LIGHT) FLASHING

NOTE:

- When ignition switch is turned to ON (engine OFF) or to "START" with the test mode connector connected, the MIL (check engine light) blinks at a cycle of 3 Hz.
- If engine fails to turn over when the ignition switch is set to START, check the spark plugs. <Ref. to 6-1 [W3B0].>

##### 2. CHECK TEST MODE CONNECTOR DISCONNECTION

NOTE:

Disconnect test mode connector. If the MIL (check engine light) illuminates with engine ON, this indicates that a trouble has occurred. Check diagnostics for CHECK ENGINE malfunction indicator lamp (MIL). <Ref. to 2-7 [T700].>

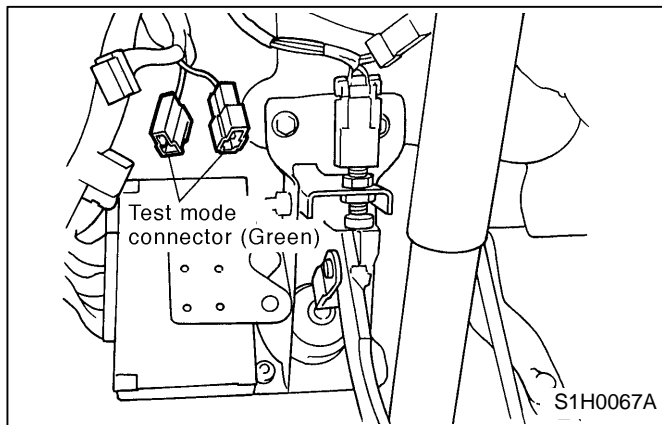

#### B: STARTING CONDITION OF ENGINE

##### CHECK POINT

###### 1. *Starting condition of engine*

Check that the engine starts quickly and runs smoothly without any abnormal noise.

##### WARNING:

- Before starting the engine, make sure that there is nothing which will burn easily behind the car and that there is no dry grass near the exhaust pipe.
- Do not leave the engine running in a closed garage as there is the danger of poisoning from the exhaust gases.
- For safety's sake, never touch the following parts while the engine is operating.
  - (1) Revolving parts such as the belt, fan, etc.
  - (2) High-temperature parts such as the exhaust pipe, radiator, etc.
  - (3) Electric system such as the plugs, cords, etc.
- Be careful not to leave inflammable paper or clothes in the engine compartment.
- Never try to disconnect hoses or wirings.

NOTE:

The engine has been tested before shipment.

#### C: OPERATION OF INDICATOR LIGHTS AND GAUGES

##### CHECK POINTS

1. *Operation of indicator lights*
2. *Operation of gauges*

Check the operation according to the "Owner's manual".

NOTE:

- Perform this inspection with the gear shift lever in the neutral position. (For automatic transmission models: Set the select lever in the "P" position.)
- Set the parking brake.
- Do not race the engine excessively.

**1-4 [G3D1]****PRE-DELIVERY INSPECTION****3. Road Test Inspection****D: TACHOMETER, RADIO, ETC.****CHECK POINT****1. Operation of tachometer, radio, etc.****1. TACHOMETER**

Race the engine two or three times, and check the tachometer's operation.

**CAUTION:**

**Do not race the engine more than necessary.**

**2. RADIO**

- 1) Install the antenna on the fender using a wrench in the antenna package.
- 2) After installation, store the wrench together with the on-board tools.
- 3) Check the operation according to the "Owner's manual".

**E: LIGHTS AND SWITCHES****CHECK POINTS**

1. **Visual inspection of lights (installation, damage, dirty lenses, water inside, etc.)**
2. **Operation of all lights and switches**
3. **Horn operation**

**F: WASHER AND WIPERS****CHECK POINTS**

1. **Checking of fluid level**
2. **Direction and quantity of washer fluid sprayed**
3. **Operation of wiper and washer**

**CAUTION:**

- Do not operate the washer when the reservoir is empty.
- Before operating the wipers, be sure to eject washer fluid onto the window. If the window is dry, the wipers' operating speed and angle of operation will be different from when it is wet.
- If the position at which washer fluid is ejected is wrong: Using an eyelet or similar tool, adjust the direction of the nozzle, be careful not to damage the nozzle hole.
- Grease, wax, insects or other material on the windshield or the wiper blades results in jerky wiper operation and unclear frontal view. If you can not get clear view after oper-

ating the windshield washer or wiper operation is jerky, clean the outer surface of the windshield and wiper blades with a neutral detergent.

**Wiper blades, windshield and rear window should be cleaned with sponge, soft cloth or mild-abrasive cleaner.**

**After cleaning, rinse the windshield and wiper blades with clean water. The windshield is clear if beads do not form when you rinse the windshield with water.**

**1. DIRECTION AND QUANTITY OF WASHER FLUID SPRAYED**

- 1) Spray windshield and rear window washers to check the amount and positions to be sprayed.

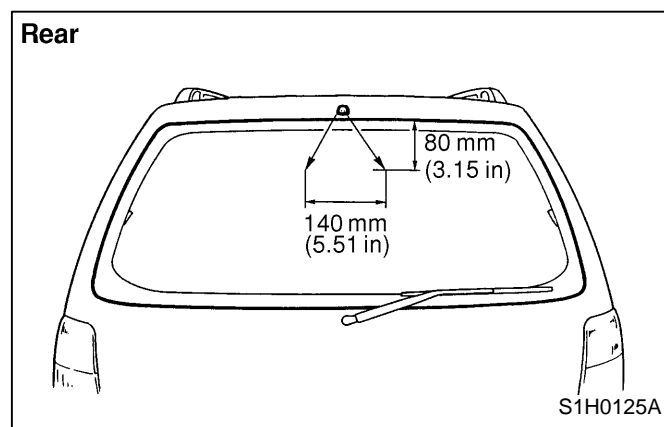
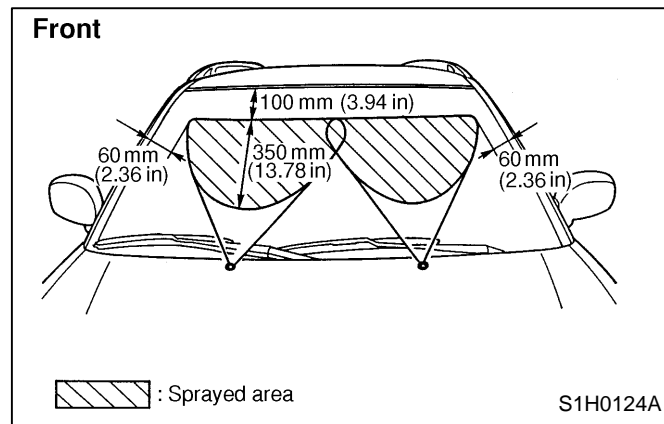

- 2) If the washer fluid was not sprayed to the specified position, adjust the direction of the washer nozzle using a needle or the like.

**G: DRIVING TEST****CHECK POINTS**

1. Operation of foot brake and parking brake
2. Operation of speedometer
3. Operation of clutch and gear shift
4. Operation of selector lever (Automatic transmission)
5. Operation of steering and position of steering wheel
6. Operation of turn signal cancel cam
7. Operation of ventilation system and heater
8. Abnormal noises or vibration
9. Operation of air conditioning
10. Operation of cruise control

**1. CHECK THE FOOT AND PARKING BRAKES' OPERATION****CAUTION:**

**Be sure to perform this test in a safe area.**

- 1) Drive on a dry, level, paved road, and apply normal braking. Look for uneven or improper operation, or pulling to one side.
- 2) Press the brake pedal in two or three times, and keep it fully depressed. Make sure that the brake can be kept that way for at least five seconds. Also check for air in the brake system, or brake fluid leakage.
- 3) Perform the adjustment of operating rod assembly as follows:
  - (1) Be sure engine is off. (No vacuum is applied to brake booster).
  - (2) There should be play between brake booster clevis and pin at brake pedal installing portion.  
[Depress brake pedal pad with a force of less than 10 N (1 kg, 2 lb) to a stroke of 1 to 3 mm (0.04 to 0.12 in).]

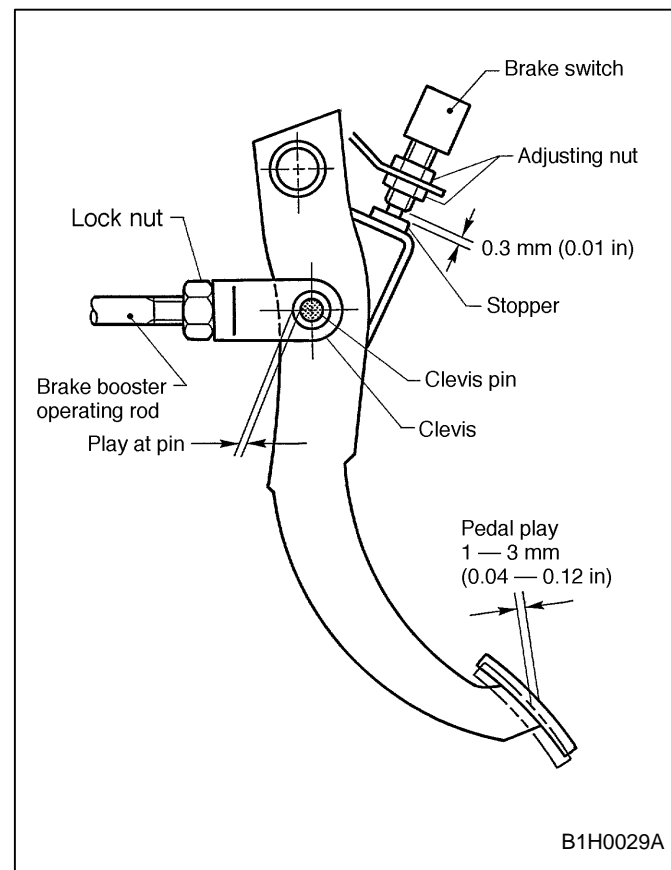

- (3) Depress the surface of brake pad by hand.
- (4) If there is no free play between clevis pin and clevis, turn brake switch adjusting nut until the clearance between stopper and screw of brake switch becomes 0.3 mm (0.01 in).
- (5) After adjustment, make sure there is no brake dragging.

- 4) Pull the parking brake lever completely out, and check its operation. Also check the ratchet for normal functioning. Check the parking brake lever stroke. If it is out of specification, adjust it by turning adjusting nut at parking brake lever.

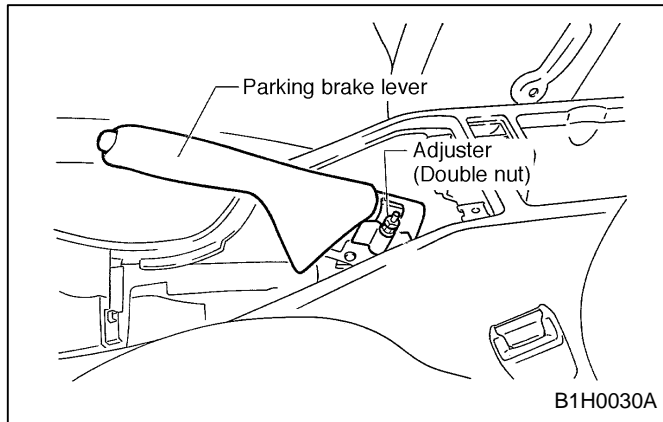
**1-4 [G3G2]****4. Post-road Test Inspection****PRE-DELIVERY INSPECTION****Standard parking brake lever stroke:  
7 — 8 notches/196 N (20 kg, 44 lb)****2. OPERATION OF SPEEDOMETER**

1) Drive the car at various speeds, and make sure that the pointer of speedometer indicates the position of each speed correctly.

**3. CHECK THE OPERATION OF CLUTCH AND GEAR SHIFTING****CAUTION:**

- Be sure to perform this test in a safe area.
- Do not repeat this test.

**NOTE:**

Carefully compare a normal clutch's operating sounds to the clutch being tested.

1) With the engine idling and the shift lever in neutral, gradually depress the clutch pedal, to see if it generates any abnormal noise.

2) Pull the parking brake lever completely out, and place wheel chocks under the tires. Then depress the clutch pedal completely, and place the shift lever in 5th speed.

Raise engine rpm a little, gradually engage the clutch, and see if the engine stalls.

If the engine stalls, it means that the clutch is not slipping.

3) Remove the wheel chocks, and return the shift lever to neutral, then check the gear shifting mechanism for excessive play.

4) Drive the car at various speeds. While depressing the clutch pedal completely, move the gear shift lever into each position, and check for any unusual play or unusual resistance.

**4. OPERATION OF SELECTOR LEVER (AUTOMATIC TRANSMISSION MODELS)**

1) Place the selector lever in each position, and make sure that the pointer indicates the position of each range correctly.

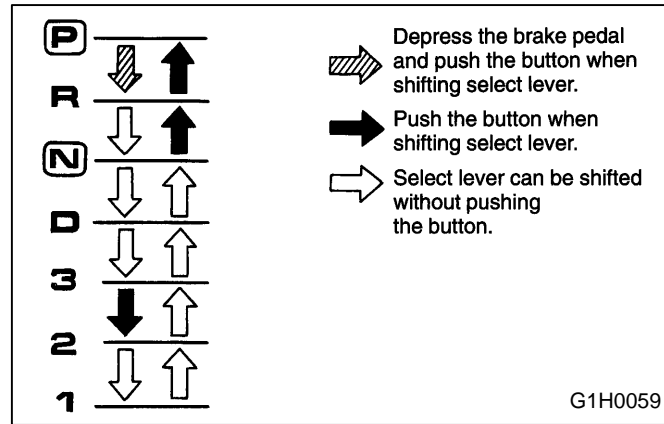
**5. OPERATION OF STEERING AND POSITION OF STEERING WHEEL**

1) Check the steering wheel for free play.

**Steering wheel free play:**

**0 — 17 mm (0 — 0.67 in)**

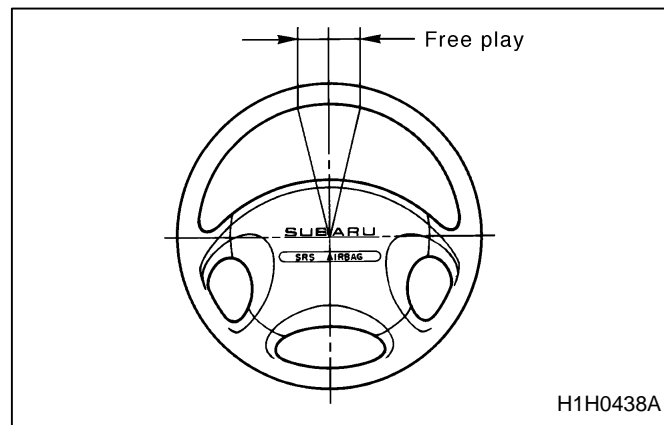

2) With the car moving straight ahead, check for hard steering, shimmy, or other abnormalities.

3) Make a turn, and check for hard or heavy steering wheel operation, or poor stability.

**6. OPERATION OF TURN SIGNAL CANCEL CAM**

Make a right or left turn with the turn signal on, and make sure that the turn signal switch returns automatically to the OFF position when the steering wheel is returned to the straight ahead position.

## 7. OPERATION OF VENTILATION SYSTEM AND HEATER

- 1) While driving, move the control lever and dial into each position, and check the ventilation system's operation. Also check for unusual vibration or noises.
- 2) Move the temperature control lever and fan switch, and make sure that warm air is discharged into the compartment.

## 8. ABNORMAL NOISES OR VIBRATION

### CAUTION:

**Be sure to perform this test in a safe area.**

- 1) When starting the engine, and while driving the vehicle, check the engine, transmission, body, suspension, and steering system for any unusual noises or vibration. Do this when idling the engine, accelerating, decelerating, and running at low, middle and high speeds.
- 2) Depress the accelerator pedal, and make sure that the engine rpm increase smoothly and that the vehicle accelerates smoothly.
- 3) While driving, turn the steering wheel right and left to test the vehicle's stability and response.

## 9. OPERATION OF AIR CONDITIONING

Turn the air conditioning switch "ON", and make sure that cool air is discharged into the compartment.

## 10. OPERATION OF THE CRUISE CONTROL

Refer to the "Owner's Manual" or "Instruction Manual".