

1-4 [G4A0]**PRE-DELIVERY INSPECTION****4. Post-road Test Inspection****4. Post-road Test Inspection****A: AUTOMATIC TRANSMISSION FLUID (ATF) LEVEL****CHECK POINT****1. Level of ATF****CAUTION:**

Do not fill above the high mark level.

NOTE:

If the fluid level is at the lower mark or below on the "HOT" side, add the recommended ATF to bring the level to the high mark. ATF is added through the level gauge hole. When the fluid level has to be checked without time to warm up the AT, check to see that the fluid level is within the marks on the "COLD" side. If it is below the marks, add fluid.

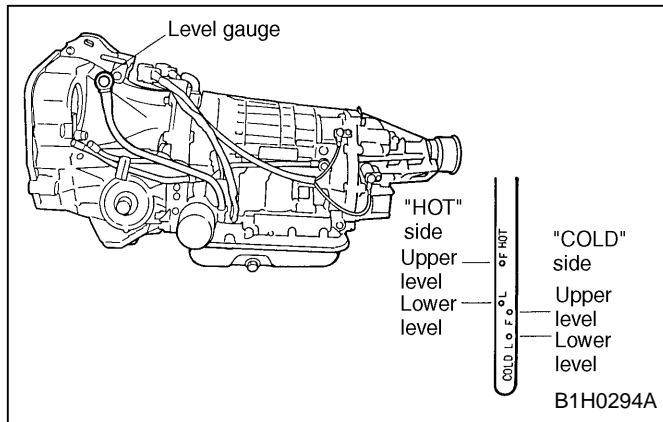

The ATF should be maintained at the proper level as follows:

- 1) Drive the car several miles to bring the transmission to the normal operating temperature. 60 to 80°C (140 to 176°F) is normal.
- 2) Park the car on a level surface.
- 3) While idling the engine, move selector lever to all ranges. Then return to the P range.
- 4) Remove the level gauge and wipe it clean.
- 5) Reinsert the level gauge completely.
- 6) Remove it again and note its reading.

Recommended automatic transmission fluid:

DEXRON II, IIE or III

B: POWER STEERING FLUID LEVEL**CHECK POINT****1. Level of power steering fluid**

The power steering fluid should be maintained at a proper level.

CAUTION:

The available power steering fluid is DEXRON II, IIE or III type automatic transmission fluid.

Be sure to use the recommended fluid.

When power steering fluid is added, be careful not to allow any dust into the tank.

Check level as follows:

- 1) Drive the car several miles or kilometers to bring power steering system up to the normal operating temperature of about 60°C (140°F).
- 2) Park the car on a level surface and stop the engine.
- 3) Remove the level gauge and wipe it clean.
- 4) Reinstall the level gauge firmly.
- 5) Remove it again and read the level on the "HOT" side.

If the fluid level is at lower point or below, add fluid to keep the level in the specified range of the indicator. If at upper point or above, drain fluid by using a syringe or the like. When the fluid level is to be checked without warming up the power steering system [at approximately 21°C (70°F)], read the fluid level at the "COLD" position of the level gauge.

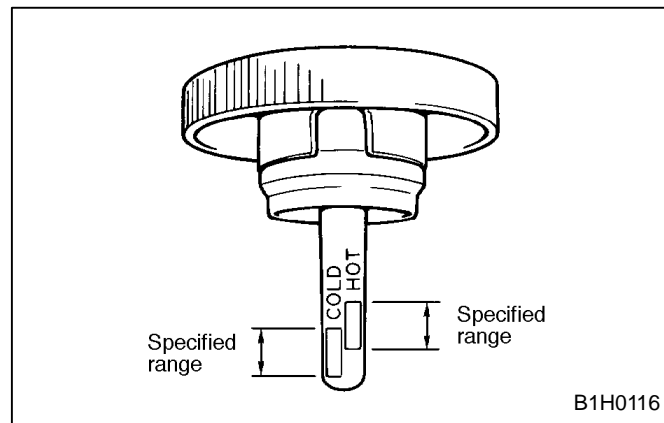

C: UNDERSIDE**CHECK POINTS**

1. **Leakage of engine oil, transmission gear oil, differential gear oil, etc.**
2. **Leakage of coolant**
3. **Leakage of brake fluid**
4. **Loose suspension mountings or steering mounting**

Raise the vehicle body and perform these checks from the underside.

- 1) Visually check for any signs of leakage of engine oil, transmission gear oil, differential gear oil, etc.
- 2) Visually check for any sign of coolant leakage.
- 3) Visually check for any sign of brake fluid leakage.
- 4) Check the suspension mounting and steering mounting for any loose or unconnected parts.

D: WATER LEAKAGE**CHECK POINT**

1. **Water leakage by pouring water**

- 1) Before performing the water leakage test, remove anything that may obstruct the operation or which must be kept dry.
- 2) Close all of the windows completely, and then close all of the doors tightly. Close the hood and trunk lid before starting the test.
- 3) Connect a hose to a tap, and spray water on the vehicle. The rate of water discharge must be approx. 20 to 25 liters (5.3 to 6.6 US gal, 4.4 to 5.5 Imp gal) per minute. When spraying water on areas adjacent to the floor and wheel house, increase the pressure.

When directing water on areas other than the floor portion and wheel house, decrease the pressure. But the force of water must be made strong occasionally by pressing the end of the hose.

NOTE:

Be sure to keep the hose at least 10 cm (3.9 in) from the vehicle.

- 4) Check the following areas:
 - (1) Front window and body framework mating portion
 - (2) Door mating portions

- (3) Glass mating portions
- (4) Rear quarter window mating portions
- (5) Rear window and body framework mating portion
- (6) Around roof drips

NOTE:

If any dampness in the compartments is discovered after the water has been applied, carefully check all areas that may have possibly contributed to the leak.

E: EXTERNAL APPEARANCE AND EQUIPMENT**CHECK POINTS**

1. **Paint**
2. **Scratches or damage to glass**
3. **Rust formation**
4. **Contamination of interior parts**
5. **Installation of equipment**

- 1) Check the paint after removing the paint protective agent and washing the vehicle.

NOTE:

Before removing the protective agent, be sure to wash the vehicle, because the painted surface may be scratched if the surface is rubbed with sand or other hard particles which may be attached to the protective agent.

- 2) Check the whole vehicle body for stains, flaking, damage caused by transportation, rust, dirt, cracks, or blistering.

NOTE:

● It is better to determine an inspection pattern in order to avoid missing an area, since the total area is not small.

● It is desirable not to make corrections to the body paint unless absolutely needed. However, if any corrections are required to remove scratches or rust, the area to be corrected must be limited as much as possible. Re-painting and spray painting must be avoided whenever possible.

- 3) Carefully check each window glass for scratches. Slight damage may be removed by polishing with cerium oxide. (Half-fill a cup with cerium oxide, and add warm water to it. Then agitate the content until it turns to wax. Apply this wax to a soft cloth, and polish the glass.)

1-4 [G4E0]**PRE-DELIVERY INSPECTION****4. Post-road Test Inspection**

4) Check each portion of the vehicle body and underside components for the formation of rust. If rust is discovered, remove it with #80 — #180 emery paper, and treat the surface with rust preventive. After this treatment is completed, flush the portion thoroughly, and prepare the surface for repair painting.

5) Check each portion of the body and all of the chrome parts for deformation or distortion. Also check each lamp lens for cracks.

6) Check the following interior parts for contamination.

- (1) Instrument panel and meter glass
- (2) Glove box
- (3) Sun visor
- (4) Room mirror
- (5) Assist rail
- (6) Roof trim
- (7) Door trim
- (8) Inner trim
- (9) Front and rear seats
- (10) Luggage shelf
- (11) Floor mat
- (12) Others

NOTE:

- If the meter glass is contaminated, wipe it gently with a clean soft cloth that has been dampened with water.
- Do not rub the meter glass hard; otherwise, the transparent resin plate on it may become clouded due to the formation of scratches.

7) Check the interior and exterior equipment to make sure that they are installed securely. Also make sure that the equipment conforms to the vehicle's specifications.

Make sure that the spare tire, jack, spare key, tools, owner's manual, warranty & service booklet, etc. are all present.