

1. Air Conditioning System

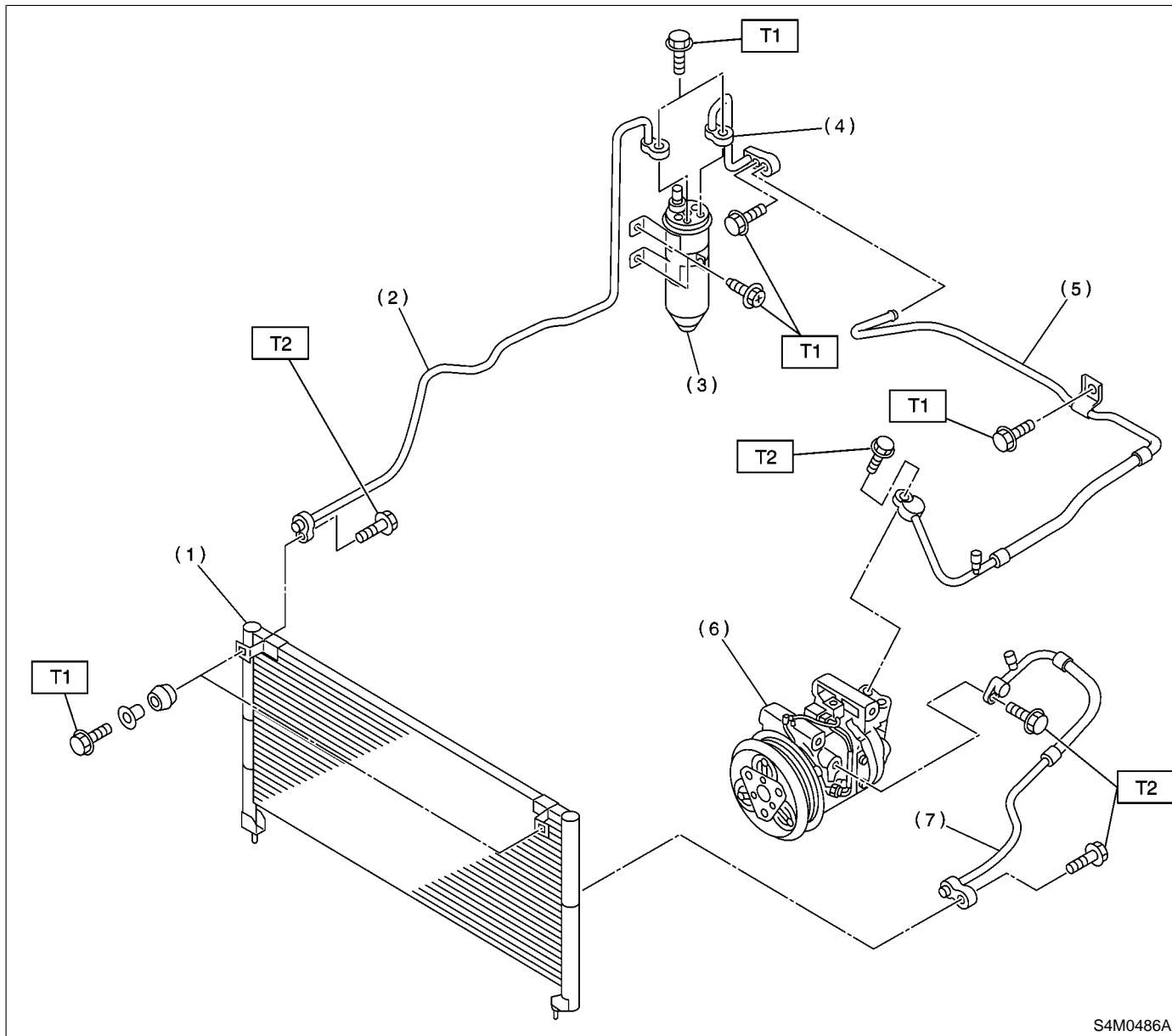

S4M0486A

- (1) Condenser
- (2) Pipe (From condenser to receiver drier)
- (3) Receiver drier
- (4) Pipe (From receiver drier to intake unit)
- (5) Hose (Low-pressure)
- (6) Compressor
- (7) Hose (High-pressure)

**Tightening torque: N·m (kg·m, ft·lb)**

**T1: 7.4±2.0 (0.75±0.2, 5.4±1.4)**

**T2: 15±5 (1.5±0.5, 10.8±3.6)**