

6) The condenser should be installed in the reverse order in which it was removed.

When installing the condenser, pay attention to the following:

CAUTION:

Before connecting the pipe, be sure to apply oil to the periphery of O-ring.

NOTE:

After installing condenser, ensure that guide (A) on lower side of condenser is inserted into hole in radiator panel (B). Tighten attaching bolts.

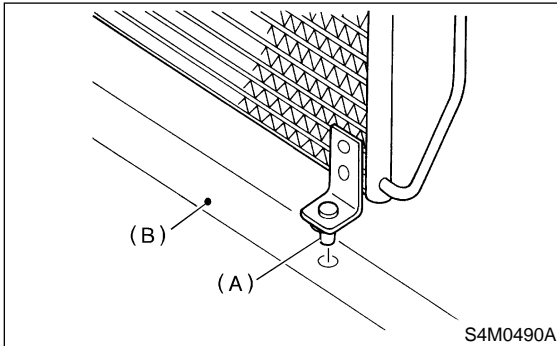

7) Charge refrigerant. <Ref. to 4-7 [W700].>

B: INSPECTION

1) Make sure the condenser fins are free from dust and insects. If the fins are clogged, clean by blowing air or water through them.

NOTE:

To prevent dust and water from getting into the condenser, this work must be done when the condenser is installed in an actual vehicle.

2) Check the condenser to see if it shows any sign of oil. Should oil ooze or gas leak from the condenser replace it with a new one.

13. Receiver Drier

A: REMOVAL AND INSTALLATION

- 1) Disconnect battery negative terminal.
- 2) Discharge refrigerant using refrigerant recovery system. <Ref. to 4-7 [W600].>
- 3) Disconnect pressure switch harness (A).
- 4) Disconnect pipes (B).
- 5) Remove mounting bolt (C) and remove receiver drier.

CAUTION:

The receiver drier contains a desiccant. Be sure to put a blind plug in the detached receiver drier to protect it from moisture.

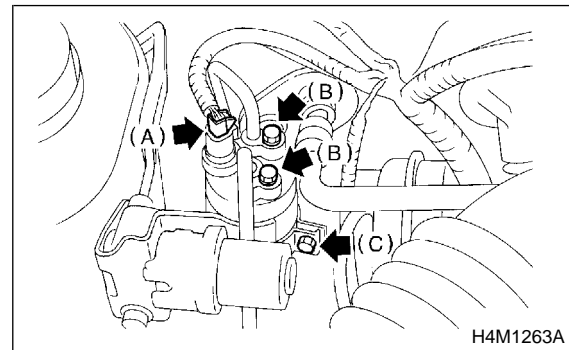

6) Install the receiver drier in the reverse order of removal.

7) Charge refrigerant. <Ref. to 4-7 [W700].>