

# 1. Front Disc Brake

## A: ON-CAR SERVICE

### 1. PAD

- 1) Remove lock pin.
- 2) Raise caliper body.
- 3) Remove pad.

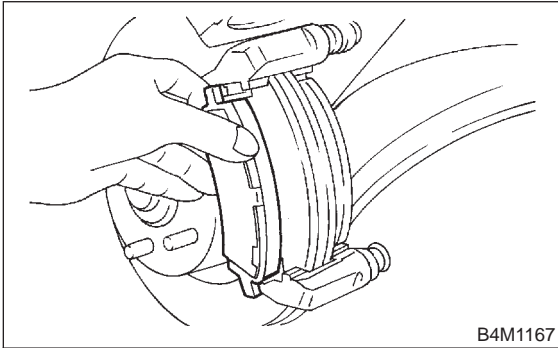

**NOTE:**

If brake pad is difficult to remove, proceed as follows:

- (1) Remove caliper body and fasten it provisionally to coil spring.
- (2) Remove support.
- (3) Place a support in a vise between wooden blocks.

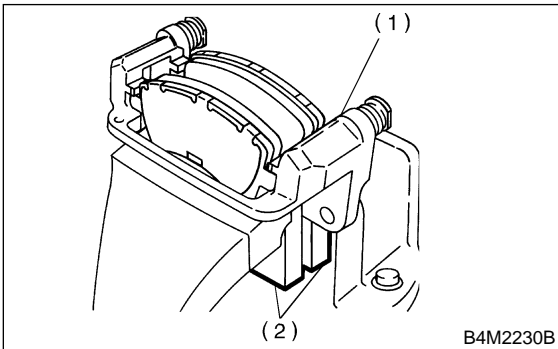

- (1) Support
- (2) Wooden blocks

- (4) Attach a rod of less than 12 mm (0.47 in) dia. to the shaded area of brake pad, and strike the rod with a hammer to drive brake pad out of place.

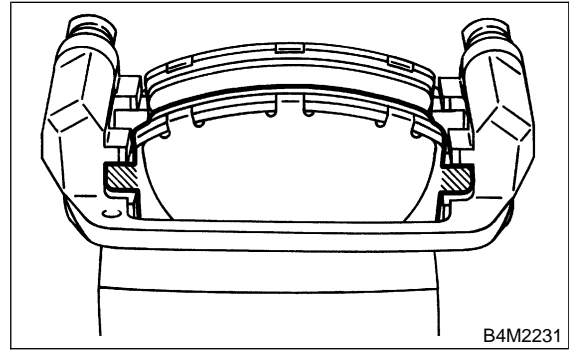

- 4) Check pad thickness A.

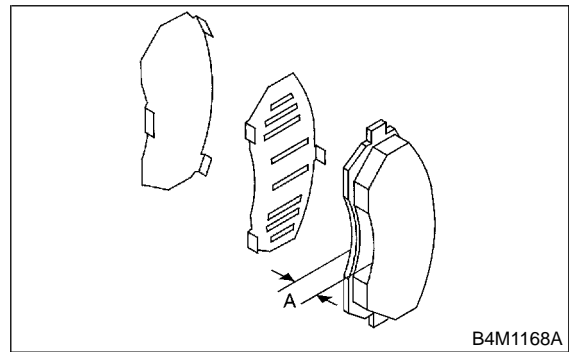

Pad thickness (including back metal)	Standard value	17 mm (0.67 in)
	Wear limit	7.5 mm (0.295 in)

**CAUTION:**

- Always replace the pads for both the left and right wheels at the same time. Also replace pad clips if they are twisted or worn.
- A wear indicator is provided on the inner disc brake pad. If the pad wears down to such an extent that the end of the wear indicator contacts the disc rotor, a squeaking sound is produced as the wheel rotates. If this sound is heard, replace the pad.
- Replace pad if there is oil or grease on it.

5) Apply a thin coat of Molykote AS880N (Part No. 26298AC000) to the frictional portion between pad and pad clip.

6) Apply a thin coat of Molykote AS880N (Part No. 26298AC000) to the frictional portion between pad and inner shim.

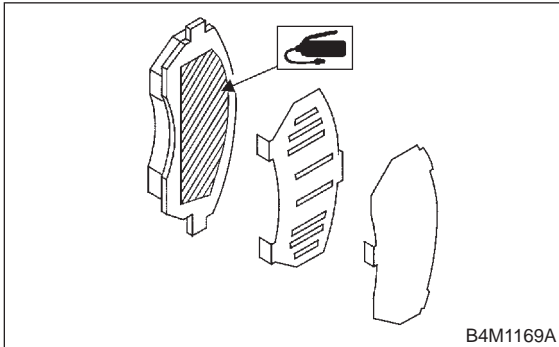

- 7) Install pads on support.
- 8) Install caliper body on support.

**NOTE:**

If it is difficult to push piston during pad replacement, loosen air bleeder to facilitate work.

## 2. DISC ROTOR

- 1) Install disc rotor by tightening the five wheel nuts.
- 2) Set a dial gauge on the disc rotor. Turn disc rotor to check runout.

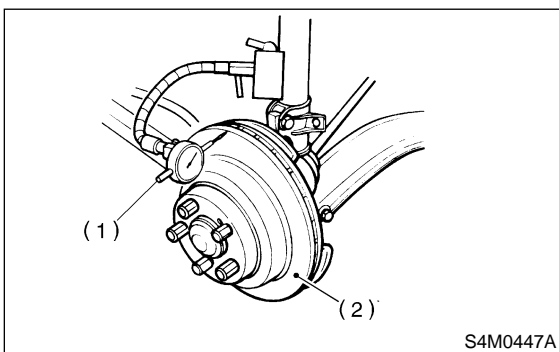

- (1) Dial gauge
- (2) Disc rotor

**NOTE:**

Make sure that dial gauge is set 5 mm (0.20 in) inward of rotor outer perimeter.

**Disc rotor runout limit:**  
**0.075 mm (0.0030 in)**

- 3) Measure disc rotor thickness.

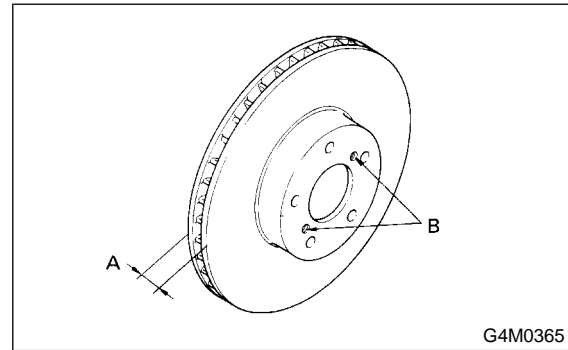

**NOTE:**

Make sure that micrometer is set 5 mm (0.20 in) inward of rotor outer perimeter.

Disc rotor thickness A	Standard value	Service limit	Disc outer dia.
	24 mm (0.94 in)	22 mm (0.87 in)	260 mm (10.24 in)

**B: REMOVAL**

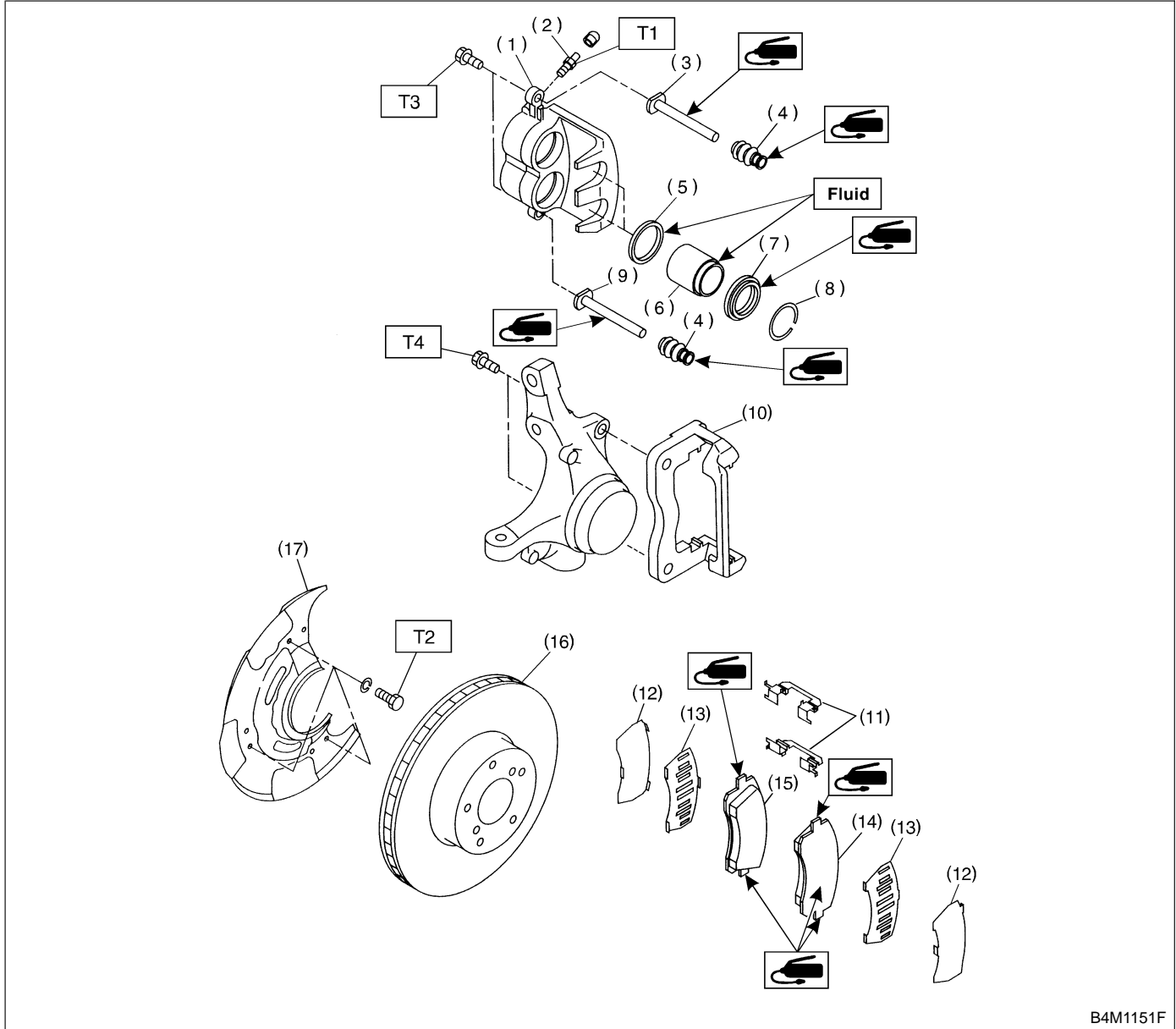

B4M1151F

- (1) Caliper body
- (2) Air bleeder screw
- (3) Guide pin (Green)
- (4) Pin boot
- (5) Piston seal
- (6) Piston
- (7) Piston boot
- (8) Boot ring

- (9) Lock pin (Yellow)
- (10) Support
- (11) Pad clip
- (12) Outer shim
- (13) Inner shim
- (14) Pad (Outside)
- (15) Pad (Inside)
- (16) Disc rotor

- (17) Disc cover

**Tightening torque: N-m (kg-m, ft-lb)**

**T1: 8±1 (0.8±0.1, 5.8±0.7)**

**T2: 18±5 (1.8±0.5, 13.0±3.6)**

**T3: 37±5 (3.8±0.5, 27.5±3.6)**

**T4: 78±10 (8.0±1.0, 58±7)**

- 1) Remove union bolt and disconnect brake hose from caliper body assembly.

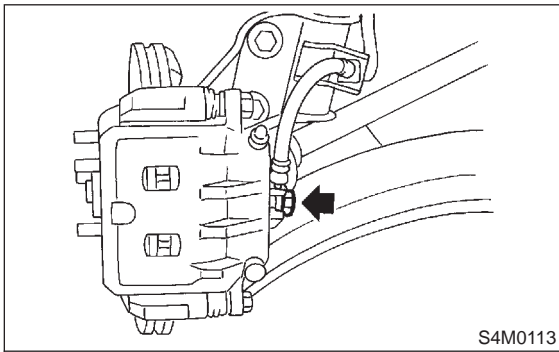

- 2) Remove bolt securing lock pin to caliper body.

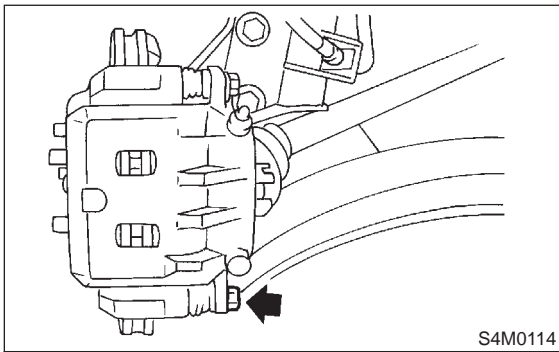

- 3) Raise caliper body and move it toward vehicle center to separate it from support.
- 4) Remove support from housing.

**NOTE:**  
Remove support only when replacing it or the rotor. It need not be removed when servicing caliper body assembly.

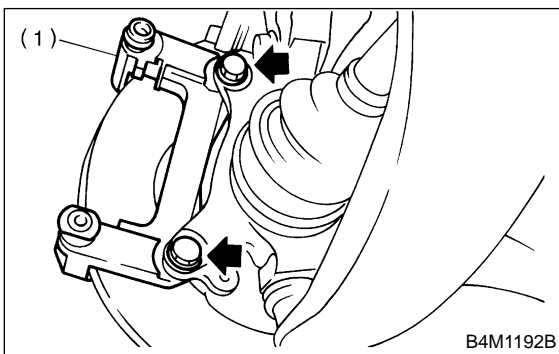

- (1) Support

- 5) Remove disc rotor from hub.

**NOTE:**  
If disc rotor seizes up within hub, drive disc rotor out by installing an 8-mm bolt in holes B on the rotor.

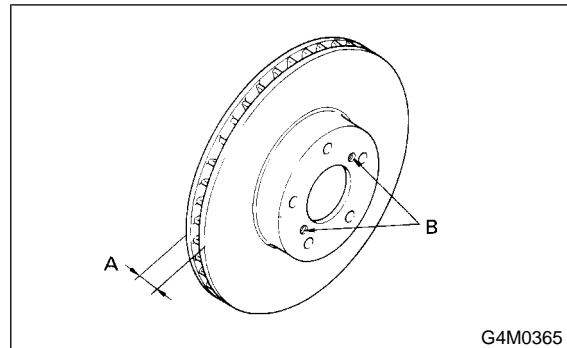

- 6) Clean mud and foreign particles from caliper body assembly and support.

## C: DISASSEMBLY

- 1) Clean mud and foreign particles from caliper body assembly and support.

**CAUTION:**  
**Be careful not to allow foreign particles to enter inlet (at brake hose connector).**

- 2) Using a standard screwdriver, remove boot ring from piston.

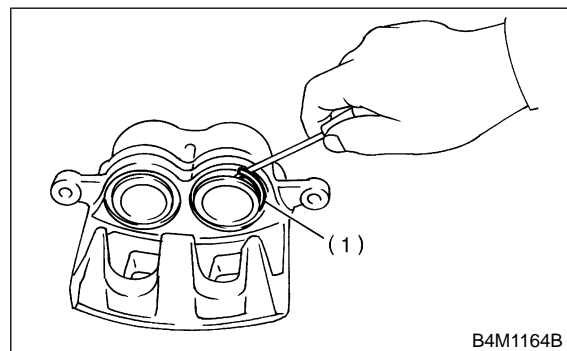

- (1) Boot ring

- 3) Remove boot from piston end.

4) Gradually supply compressed air via caliper body brake hose to force piston out.

**CAUTION:**

Place a wooden block as shown in Figure to prevent damage to piston.

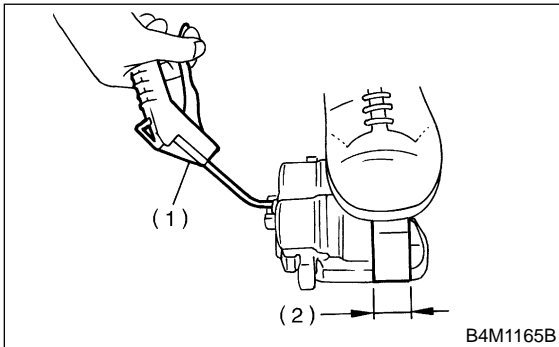

- (1) Air gun
- (2) Place a 30 mm (1.18 in) wide wooden block here.

5) Remove piston seal from caliper body cylinder.

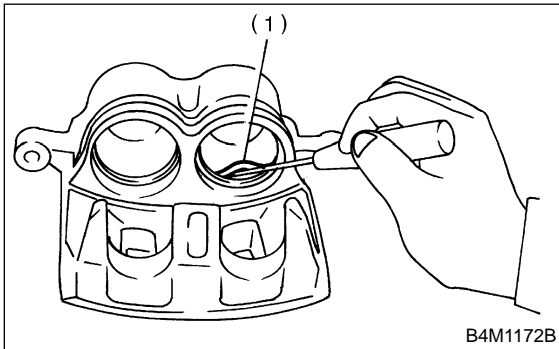

- (1) Piston seal

6) Remove lock pin boot and guide pin boot.

**D: INSPECTION**

- 1) Repair or replace faulty parts.
- 2) Check caliper body and piston for uneven wear, damage or rust.
- 3) Check rubber parts for damage or deterioration.

**E: ASSEMBLY**

- 1) Clean caliper body interior using brake fluid.
- 2) Apply a coat of brake fluid to piston seal and fit piston seal in groove on caliper body.
- 3) Apply a coat of brake fluid to the entire inner surface of cylinder and outer surface of piston.
- 4) Insert piston into cylinder.

**CAUTION:**

Do not force piston into cylinder.

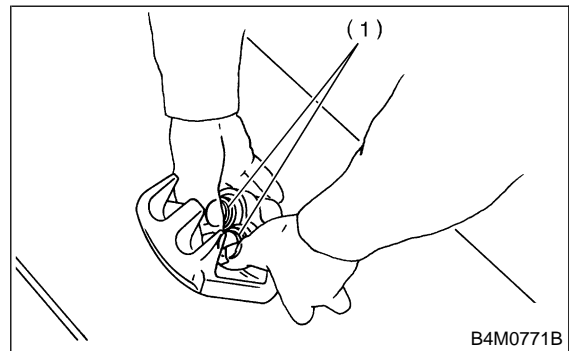

- (1) Piston

5) Apply a coat of specified grease to boot and fit in groove on ends of cylinder and piston.

**Grease:**

**NIGLUBE RX-2 (Part No. 003606000)**

To facilitate installation, fit boot starting with piston end.

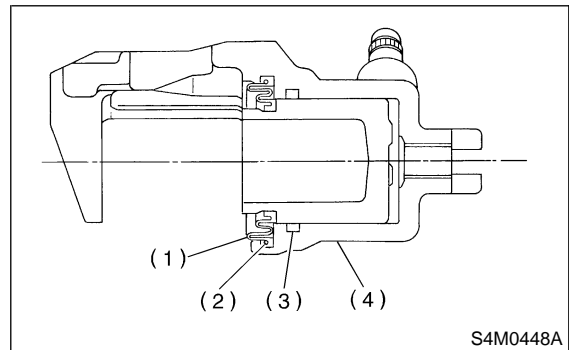

- (1) Piston boot
- (2) Boot ring
- (3) Piston seal
- (4) Caliper body

- 6) Position boot in grooves on cylinder and piston.
- 7) Install boot ring. Be careful not scratch boot.

8) Apply a coat of specified grease to lock pin and guide pin, outer surface, cylinder inner surface, and boot grooves.

**Grease:**

**NIGLUBE RX-2 (Part No. 003606000)**

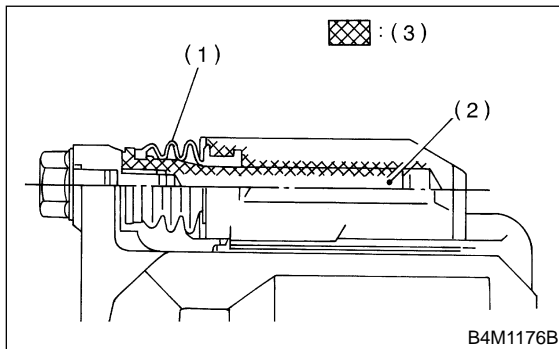

- (1) Pin boot
- (2) Lock pin or guide pin
- (3) Apply grease.

9) Install lock pin boot and guide pin boot on support.

## F: INSTALLATION

- 1) Install disc rotor on hub.
- 2) Install support on housing.

**Tightening torque:**

**$78 \pm 10$  N·m ( $8 \pm 1$  kg·m,  $58 \pm 7$  ft·lb)**

**CAUTION:**

- Always replace the pads for both the left and right wheels at the same time. Also replace pad clips if they are twisted or worn.

- A wear indicator is provided on the inner disc brake pad. If the pad wears down to such an extent that the end of the wear indicator contacts the disc rotor, a squeaking sound is produced as the wheel rotates. If this sound is heard, replace the pad.

- When replacing the pad, replace pads of the right and left wheels at the same time.

3) Apply a thin coat of Molykote AS880N (Part No. 26298AC000) to the frictional portion between pad and pad clip.

4) Apply a thin coat of Molykote AS880N (Part No. 26298AC000) to the frictional portion between pad and inner shim.

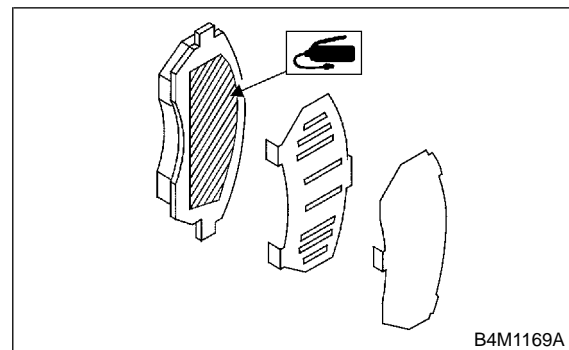

5) Install pads, rubber coated shim and stainless shim on support.

6) Install caliper body on support.

**Tightening torque:**

**$39 \pm 5$  N·m ( $4 \pm 0.5$  kg·m,  $28.9 \pm 3.6$  ft·lb)**

7) Connect brake hose.

**Tightening torque:**

**$18 \pm 3$  N·m ( $1.8 \pm 0.3$  kg·m,  $13.0 \pm 2.2$  ft·lb)**

**CAUTION:**

**Replace brake hose gaskets with new ones.**

8) Bleed air from brake system.