

3. Blower Motor Assembly

A: REMOVAL AND INSTALLATION

- 1) Disconnect ground cable from battery.
- 2) Remove glove box.

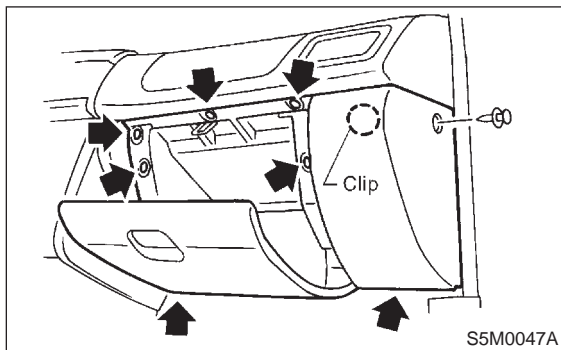

- 3) Disconnect blower motor harness connector.
- 4) Disconnect aspirator pipe (A).
- 5) Remove blower motor mounting screw.

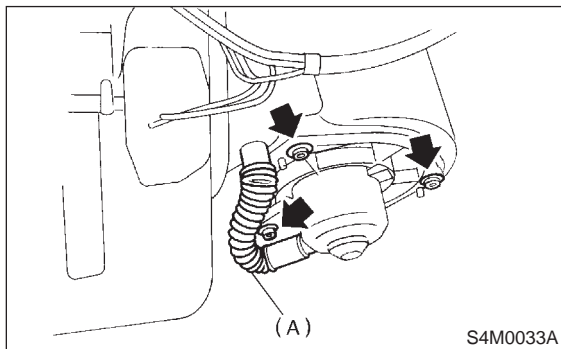

- 6) Remove blower motor assembly.
- 7) Install in the reverse order of removal.

4. Control Unit

A: REMOVAL AND INSTALLATION

- 1) Disconnect ground cable from battery.
- 2) Set temperature control switch to "FULL HOT" and mode selector switch to "DEF" position and recirc switch to "FRESH" position.
- 3) Disconnect temperature control cable and mode door control cable from heater unit then disconnect recirc control cable from intake unit.

NOTE:

Do not attempt to move links during installation.

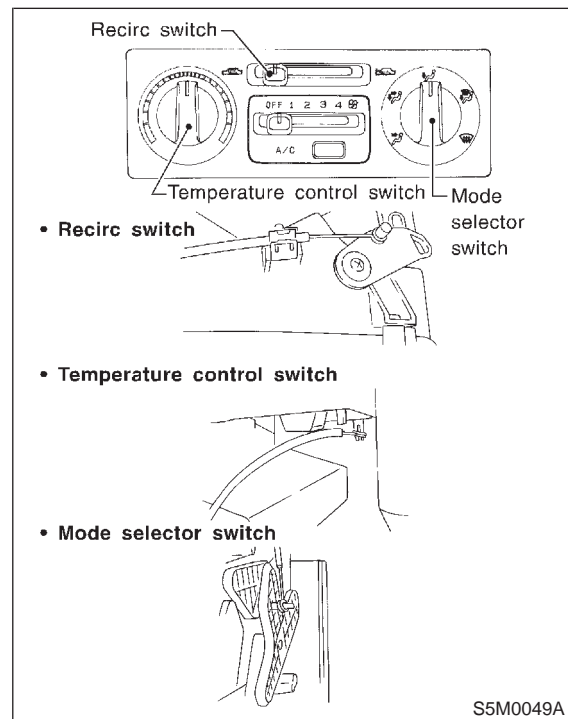

- 4) Remove console box. <Ref. to 5-4 [W1A0].>
- 5) Remove center panel and then disconnect connector.
- 6) Remove audio.

