

3. Steering Gearbox (Power Steering System)

A: REMOVAL

NOTE:

For disassembly and assembly of gearbox unit, refer to section Control Valve (Power Steering Gearbox).
 <Ref. to 4-3 [W4B0].> and <Ref. to 4-3 [W4D0].>

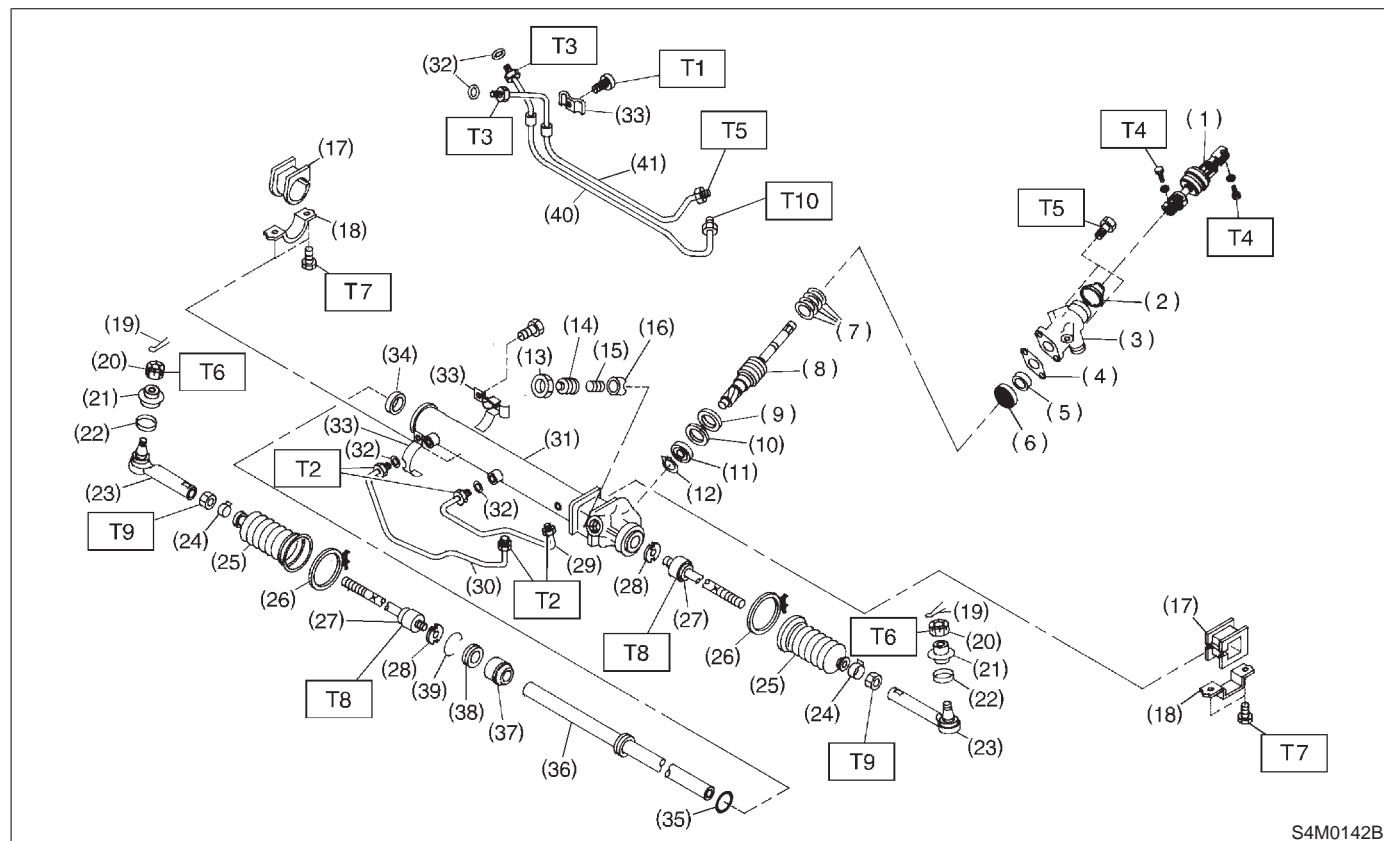

S4M0142B

- | | | |
|---------------------------|-------------------|-------------------|
| (1) Universal joint | (19) Cotter pin | (37) Rack bushing |
| (2) Dust cover | (20) Castle nut | (38) Rack stopper |
| (3) Valve housing | (21) Dust cover | (39) Circlip |
| (4) Gasket | (22) Clip | (40) Pipe E |
| (5) Oil seal | (23) Tie-rod end | (41) Pipe F |
| (6) Special bearing | (24) Clip | |
| (7) Seal ring | (25) Boot | |
| (8) Pinion and valve ASSY | (26) Band | |
| (9) Oil seal | (27) Tie-rod | |
| (10) Back-up washer | (28) Lock washer | |
| (11) Ball bearing | (29) Pipe B | |
| (12) Snap ring | (30) Pipe A | |
| (13) Lock nut | (31) Housing ASSY | |
| (14) Adjusting screw | (32) O-ring | |
| (15) Spring | (33) Clamp | |
| (16) Sleeve | (34) Oil seal | |
| (17) Adapter | (35) Piston ring | |
| (18) Clamp | (36) Rack | |

Tightening torque: N·m (kg·m, ft·lb)

T1:	6±1 (0.6±0.1, 4.3±0.7)
T2:	13±3 (1.3±0.3, 9.4±2.2)
T3:	15±5 (1.5±0.5, 10.8±3.6)
T4:	24±3 (2.4±0.3, 17.4±2.2)
T5:	25±5 (2.5±0.5, 18.1±3.6)
T6:	27.0±2.5 (2.75±0.25, 19.9±1.8)
T7:	59±12 (6.0±1.2, 43±9)
T8:	78±10 (8.0±1.0, 58±7)
T9:	83±5 (8.5±0.5, 61.5±3.6)
T10:	15±3 (1.5±0.3, 10.8±2.2)

3. Steering Gearbox (Power Steering System)

- 1) Disconnect battery minus terminal.
- 2) Loosen front wheel nut.
- 3) Lift vehicle and remove front wheels.
- 4) Remove front exhaust pipe assembly.

WARNING:

Be careful, exhaust pipe is hot.

- 5) Using a puller, remove tie-rod end from knuckle arm after pulling off cotter pin and removing castle nut.

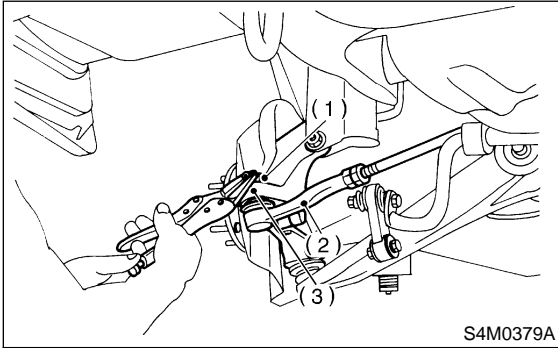

- (1) Castle nut
- (2) Tie-rod end
- (3) Knuckle arm

- 6) Remove jack-up plate and front stabilizer.

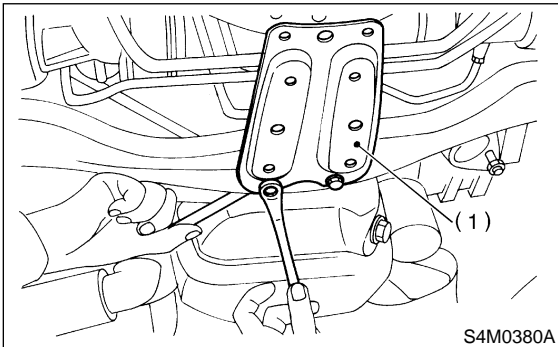

- (1) Jack-up plate

- 7) Remove one pipe joint at the center of gearbox, and connect vinyl hose to pipe and joint. Discharge fluid by turning steering wheel fully clockwise and counterclockwise. Discharge fluid similarly from the other pipe.

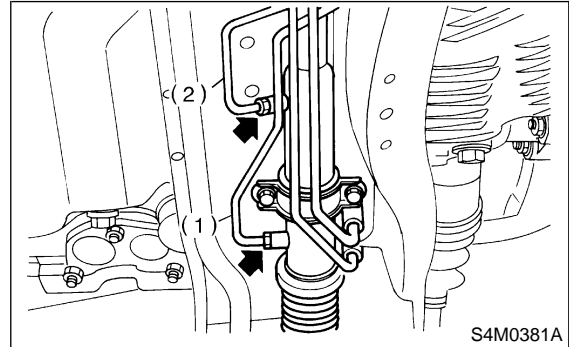

- (1) Pipe A
- (2) Pipe B

- 8) Remove lower side bolt of universal joint, then remove upper side bolt and lift the joint upward.

NOTE:

Place a mark on the joint and mating serration so that they can be re-installed at the original position.

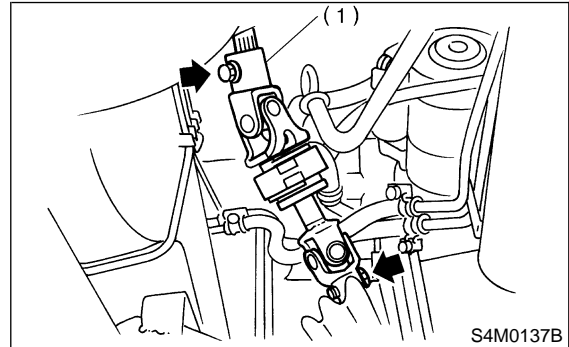

- (1) Universal joint

9) Disconnect pipes C and D from pipe of gear-
box.

CAUTION:

Be careful not to damage these pipes.

NOTE:

Disconnect upper pipe D first, and lower pipe C
second.

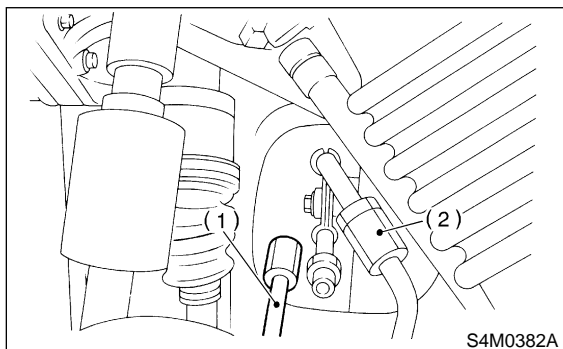

- (1) Pipe C
- (2) Pipe D

10) Remove clamp bolts securing gearbox to
crossmember, and remove gearbox.

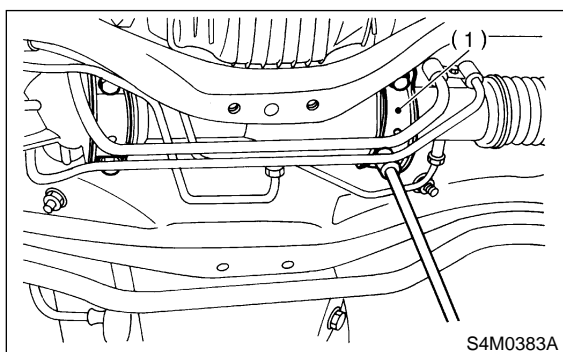

- (1) Clamp

B: DISASSEMBLY

- 1) Disconnect the four pipes from gearbox.
- 2) Secure gearbox removed from vehicle in vice
using ST.

ST 926200000 STAND

CAUTION:

**Secure the gearbox in a vice using the ST as
shown. Do not attempt to secure it without this
ST.**

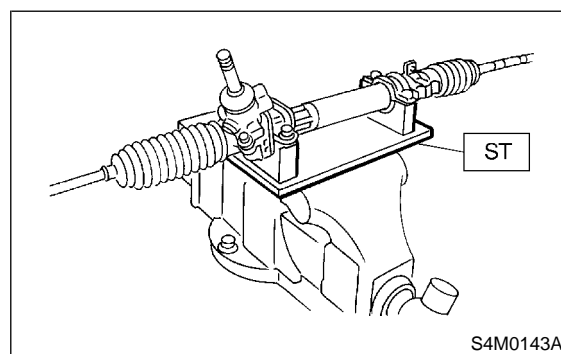

- 3) Remove tie-rod end and lock nut from gearbox.
- 4) Remove small clip from boot using pliers, and
move boot to tie-rod end side.

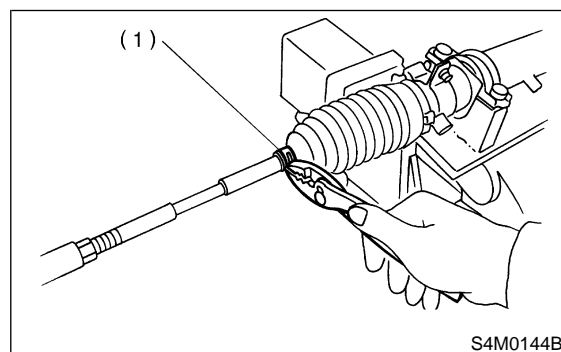

- (1) Clip

5) Using standard screwdriver, remove band from
boot.

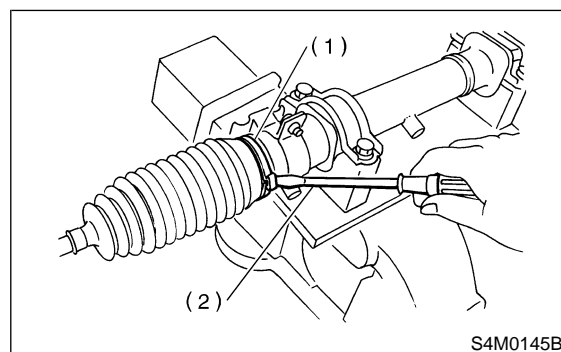

- (1) Band
- (2) Standard screwdriver

3. Steering Gearbox (Power Steering System)

6) Extend rack approximately 40 mm (1.57 in) out. Unlock lock wire at lock washer on each side of tie-rod end using a standard screwdriver.

CAUTION:

Be careful not to scratch rack surface as oil leaks may result.

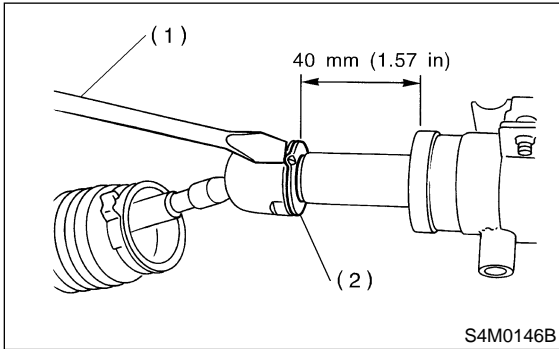

- (1) Standard screwdriver
- (2) Lock washer

7) Using ST, loosen lock nut.
ST 926230000 SPANNER

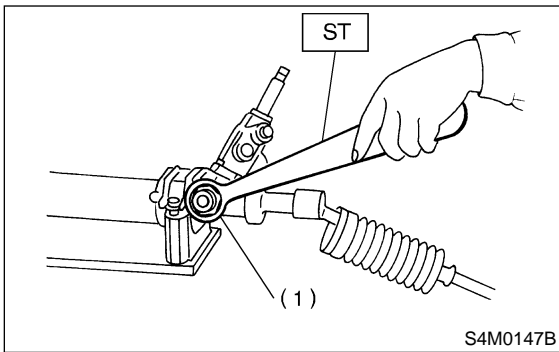

- (1) Lock nut

8) Tighten adjusting screw until it no longer tightens.

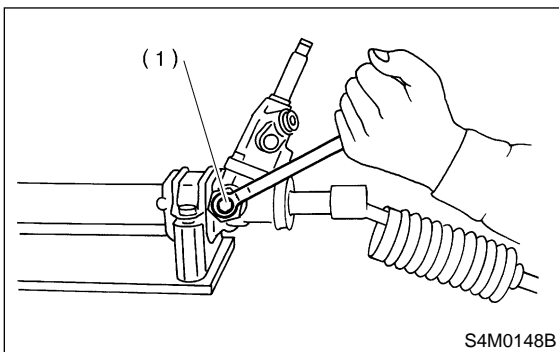

- (1) Adjusting screw

9) Using a wrench [32 mm (1.26 in) width across flats] or adjustable wrench, remove tie-rod.

CAUTION:

- Check ball joint for free play, and tie-rod for bends. Replace if necessary.
- Check dust seals used with tie-rod end ball joint for damage or deterioration. Replace if necessary.

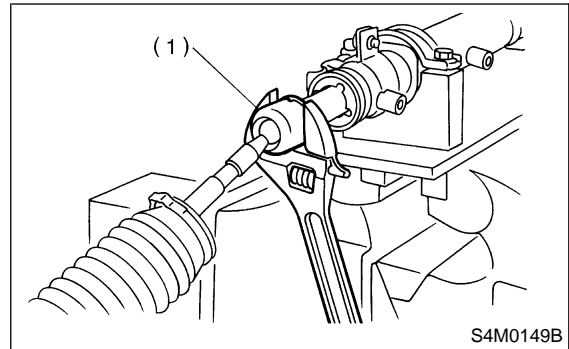

- (1) Tie-rod

10) Loosen adjusting screw and remove spring and sleeve.

CAUTION:

Replace spring and/or sleeve if damaged.

C: INSPECTION

- 1) Clean all disassembled parts, and check for wear, damage, or any other faults, then repair or replace as necessary.
- 2) When disassembling, check inside of gearbox for water. If any water is found, carefully check boot for damage, input shaft dust seal, adjusting screw and boot clips for poor sealing. If faulty, replace with new parts.

No.	Parts	Inspection	Corrective action
1	Input shaft	(1) Bend of input shaft (2) Damage on serration	If bend or damage is excessive, replace entire gearbox.
2	Dust seal	(1) Crack or damage (2) Wear	If outer wall slips, lip is worn out or damage is found, replace it with new one.
3	Rack and pinion	Poor mating of rack with pinion	(1) Adjust backlash properly. By measuring turning torque of gearbox and sliding resistance of rack, check if rack and pinion engage uniformly and smoothly with each other. (Refer to "Service limit".) (2) Keeping rack pulled out all the way so that all teeth emerge, check teeth for damage. Even if abnormality is found in either (1) or (2), replace entire gearbox.
4	Gearbox unit	(1) Bend of rack shaft (2) Bend of cylinder portion (3) Crack or damage on cast iron portion	Replace gearbox with new one.
		(4) Wear or damage on rack bush	If free play of rack shaft in radial direction is out of the specified range, replace gearbox with new one. (Refer to "Service limit".)
		(5) Wear on input shaft bearing	If free plays of input shaft in radial and axial directions are out of the specified ranges, replace gearbox with new one. (Refer to "Service limit".)
5	Boot	Crack, damage or deterioration	Replace.
6	Tie-rod	(1) Looseness of ball joint (2) Bend of tie-rod	Replace.
7	Tie-rod end	Damage or deterioration on dust seal	Replace.
8	Adjusting screw spring	Deterioration	Replace.
9	Boot clip	Deterioration	Replace.
10	Sleeve	Damage	Replace.
11	Pipes	(1) Damage to flared surface (2) Damage to flare nut (3) Damage to pipe	Replace.

1. SERVICE LIMIT

Make a measurement as follows. If it exceeds the specified service limit, adjust or replace.

NOTE:

When making a measurement, vise gearbox by using ST. Never vise gearbox by inserting aluminum plates, etc. between vise and gearbox.

ST 926200000 STAND

Sliding resistance of rack shaft:

Service limit

304.0 N (31.0 kg, 68.4 lb) or less

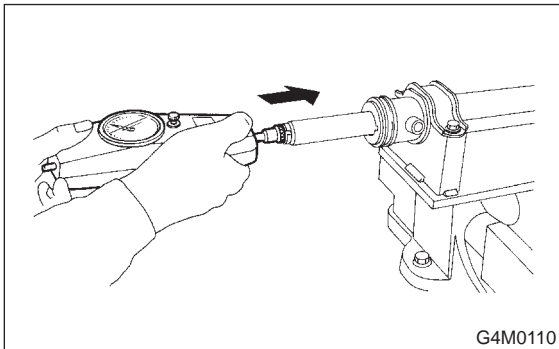
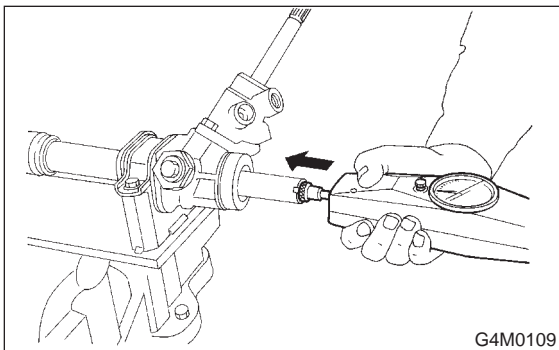

2. RACK SHAFT PLAY IN RADIAL DIRECTION

Right-turn steering:

Service limit

0.15 mm (0.0059 in) or less

On condition

L: 5 mm (0.20 in)

P: 98 N (10 kg, 22 lb)

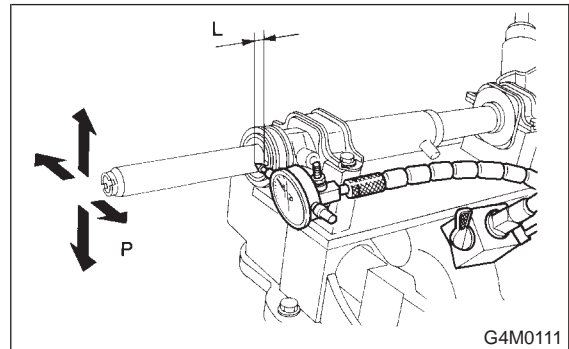

Left-turn steering:

Service limit

Direction ← →

0.3 mm (0.012 in) or less

Direction ← →

0.15 mm (0.0059 in) or less

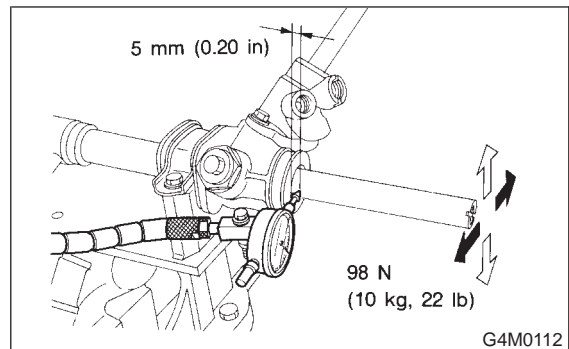

3. INPUT SHAFT PLAY

In radial direction:

Service limit

0.18 mm (0.0071 in) or less

On condition

P: 98 N (10 kg, 22 lb)

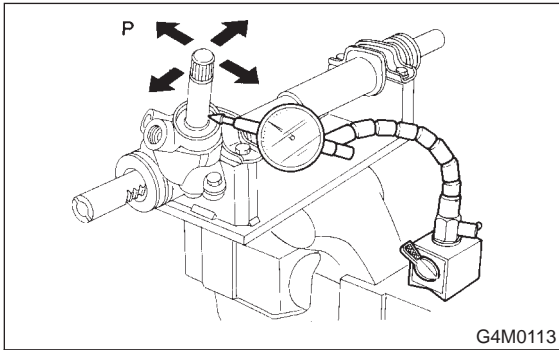

In axial direction:

Service limit

0.1 mm (0.004 in) or less

On condition

P: 20 — 49 N (2 — 5 kg, 4 — 11 lb)

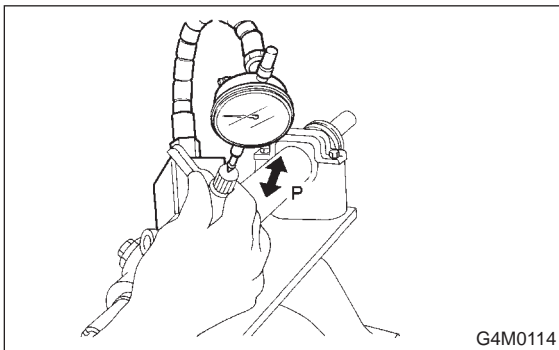

4. TURNING RESISTANCE OF GEARBOX

Using ST, measure gearbox turning resistance.

ST 926230000 SPANNER

Service limit:

Straight-ahead position within 30 mm (1.18 in) from rack center

Less than 11.18 N (1.14 kg, 2.51 lb)

Maximum allowable resistance

12.7 N (1.3 kg, 2.9 lb)

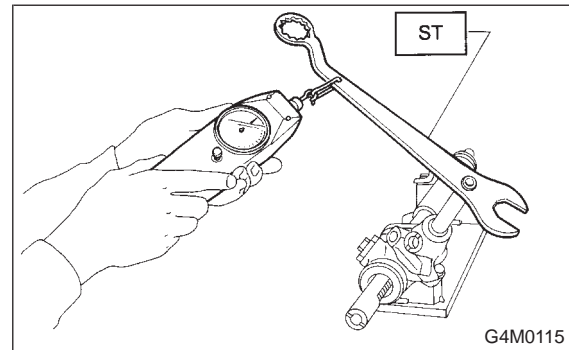

D: ASSEMBLY**CAUTION:**

Use only SUBARU genuine grease for gearbox.

Grease:

VALIANT GREASE M2

[Part No. 003608001, net 0.5 kg (1.1 lb)]

- 1) Clean all parts and tools before reassembling.
- 2) Apply grease to teeth of rack so that grease applied is about as high as teeth, and also apply a thin film of grease to sliding portion of rack shaft.

CAUTION:

- When moving rack to stroke end without tie-rod attached, prevent shocks from being applied at the end.
- Do not apply grease to threaded portion at end of rack shaft.
- Move rack shaft to stroke end two or three times to squeeze grease which accumulates on both ends. Remove grease to prevent it from choking air passage hole.

- 3) Apply grease to sleeve insertion hole.
- 4) Apply grease to dust seal insertion hole.

CAUTION:

Apply clean grease with clean hands. If material having a sharp edge is used for applying grease, oil seal at the inside might be damaged.

- 5) Apply grease to sliding surface of sleeve and spring seat, then insert sleeve into pinion housing. Fit spring into sleeve screw, pack grease inside of screw, then install the screw.

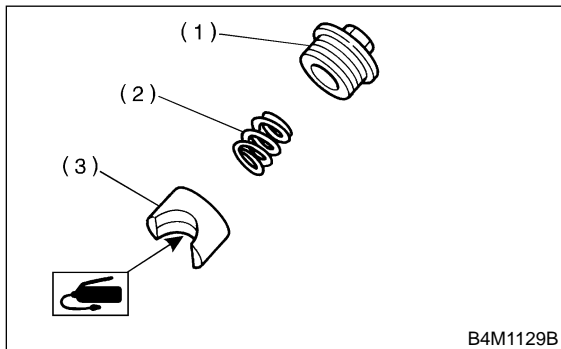

- (1) Adjusting screw
- (2) Spring
- (3) Sleeve

- 6) Install lock washers and tighten left and right tie-rods into rack ends.

On condition

L: Approximately 40 mm (1.57 in)

Tightening torque:

78±10 N·m (8.0±1.0 kg·m, 58±7 ft·lb)

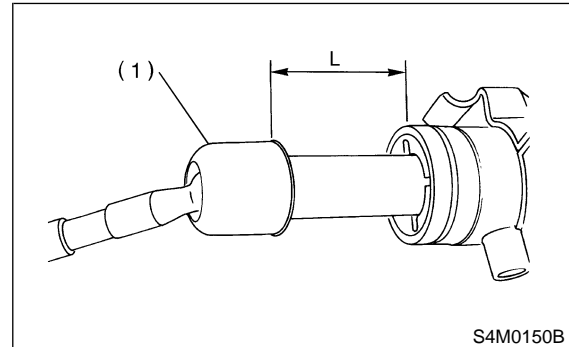

- (1) Tie-rod

- 7) Bend lock washer using a chisel.

CAUTION:

Be careful not to scratch rack when bending lock washer.

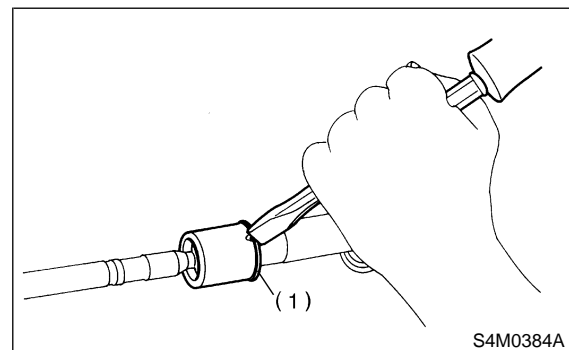

- (1) Lock washer

- 8) Rack and pinion backlash adjustment
- (1) Loosen adjusting screw.
 - (2) Rotate input shaft so that rack is in the straight ahead direction.
 - (3) Apply grease to sleeve.

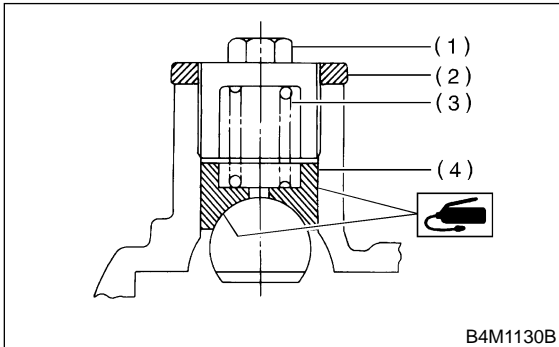

- (1) Adjusting screw
- (2) Lock nut
- (3) Spring
- (4) Sleeve

- (4) Tighten adjusting screw by the two threads.

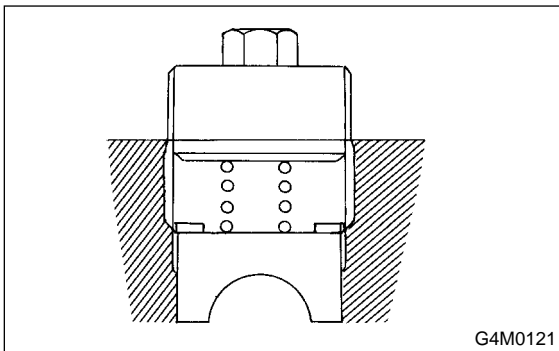

- (5) Apply liquid packing to at least 1/3 of entire perimeter of adjusting screw thread.

Liquid packing:
THREE BOND 1141

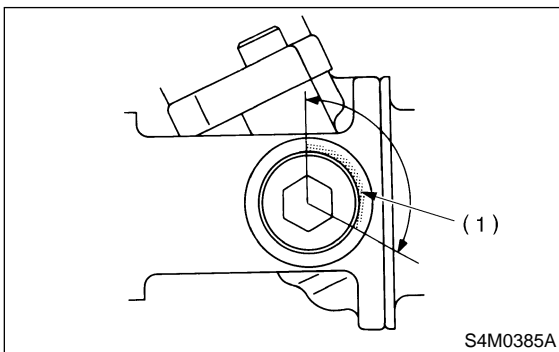

- (1) Apply liquid packing to at least 1/3 of entire perimeter.

- (6) Tighten adjusting screw to 7.4 N-m (0.75 kg-m, 5.4 ft-lb) and back off 25°.

- (7) Install lock nut. While holding adjusting screw with a wrench, tighten lock nut using ST. ST 926230000 SPANNER

Tightening torque (Lock nut):
39±10 N-m (4.0±1.0 kg-m, 29±7 ft-lb)

NOTE:

- Hold adjusting screw with a wrench to prevent it from turning while tightening lock nut.
- Make adjustment so that steering wheel can be rotated fully from lock to lock without binding.

- 9) Check for service limit as per article of "Service limit". <Ref. to 4-3 [W3C1].> Make replacement and adjustment if necessary.

- 10) Install boot to housing.

NOTE:

- Before installing boot, be sure to apply grease to the groove of tie-rod.
- Install fitting portions of boots to the following portions in both sides of assembled steering gearbox.

The groove on gearbox

The groove on the rod

- Make sure that boot is installed without unusual inflation or deflation.

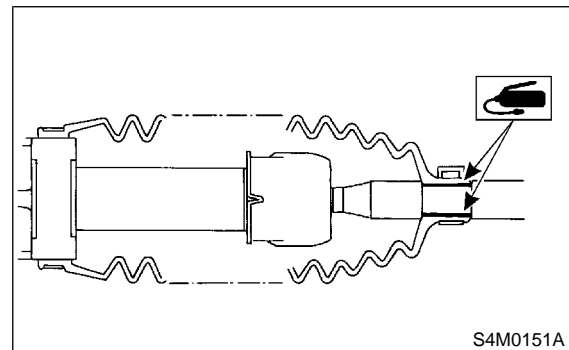

3. Steering Gearbox (Power Steering System)

11) Using a screwdriver, tighten the screw until the ends "A" and "B" of the band come into contact with each other.

CAUTION:

Use a new band.

NOTE:

Always tighten the band from the underside of the gearbox.

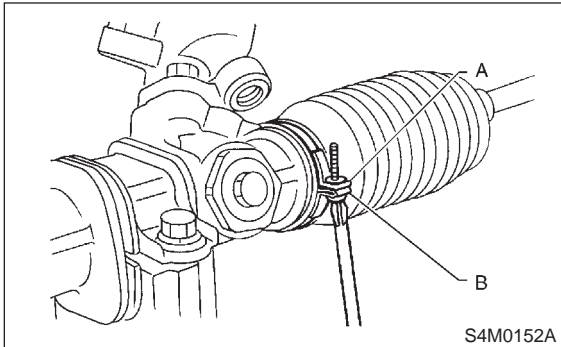

12) Fix boot end with clip (small).

CAUTION:

After installing, check boot end is positioned into groove on tie-rod.

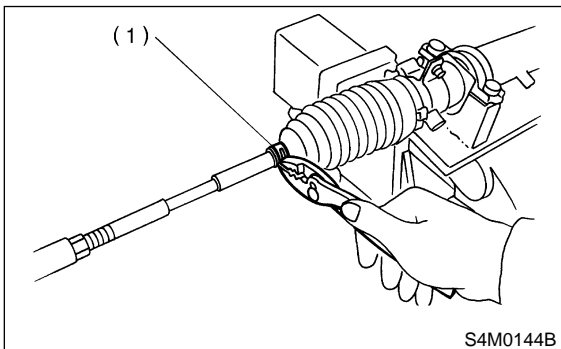

(1) Clip

13) If tie-rod end was removed, screw in lock nut and tie-rod end to screwed portion of tie-rod, and tighten lock nut temporarily in a position as shown in figure.

Installed tie-rod length: L

15 mm (0.59 in)

NOTE:

Pay attention to difference between right and left tie-rod ends.

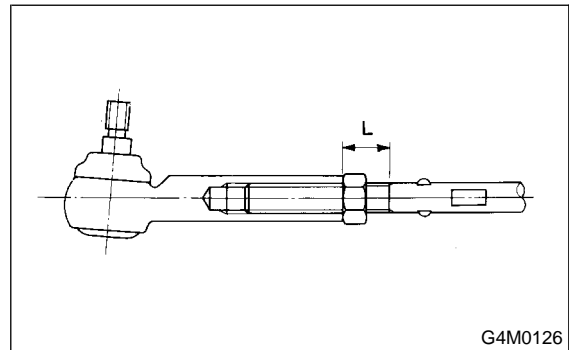

14) Inspect gearbox as follows:

"A" Holding tie-rod end, repeat lock to lock two or three times as quickly as possible.

"B" Holding tie-rod end, turn it slowly at a radius one or two times as large as possible.

After all, make sure that boot is installed in the specified position without deflation.

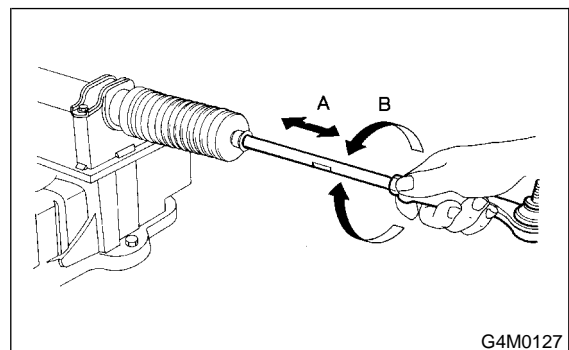

15) Remove gearbox from ST.

ST 926200000 STAND

16) Install the four pipes on gearbox.

(1) Connect pipes A and B to the four pipe joints of gearbox. Connect upper pipe B first, and lower pipe A.

Tightening torque:

13±3 N·m (1.3±0.3 kg·m, 9.4±2.2 ft·lb)

- (2) Connect pipes C and D to gearbox.
Connect lower pipe C first, and upper pipe D second.

Tightening torque:

$15 \pm 5 \text{ N}\cdot\text{m}$ ($1.5 \pm 0.5 \text{ kg}\cdot\text{m}$, $10.8 \pm 3.6 \text{ ft}\cdot\text{lb}$)

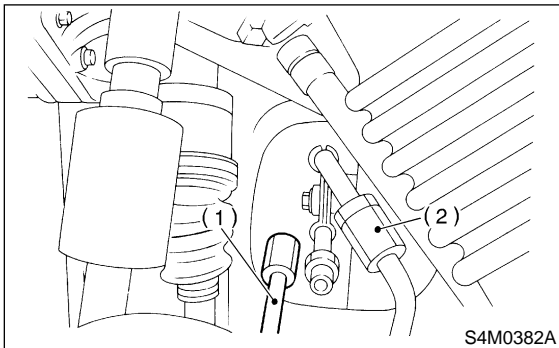

- (1) Pipe C
(2) Pipe D

E: INSTALLATION

- 1) Insert gearbox into crossmember, being careful not to damage gearbox boot.
2) Tighten gearbox to crossmember bracket via clamp with bolt to the specified torque.

Tightening torque:

$59 \pm 12 \text{ N}\cdot\text{m}$ ($6.0 \pm 1.2 \text{ kg}\cdot\text{m}$, $43 \pm 9 \text{ ft}\cdot\text{lb}$)

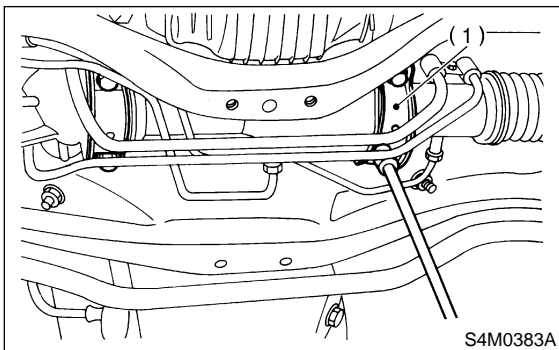

- (1) Clamp

3) How to install the joint.

- (1) Push the long yoke of the joint, all the way into the serrated portion of the steering shaft, setting the bolt hole in the cutout.
(2) Then pull the short yoke all way out of the serrated portion of the gearbox, setting the bolt hole in the cutout.
(3) Insert the bolt through the short yoke, pull the joint and confirm that the bolt is on cutout of the gearbox.

- (4) Fasten the short yoke side with a spring washer and bolt, then fasten the long yoke side.

Tightening torque:

$24 \pm 3 \text{ N}\cdot\text{m}$ ($2.4 \pm 0.3 \text{ kg}\cdot\text{m}$, $17.4 \pm 2.2 \text{ ft}\cdot\text{lb}$)

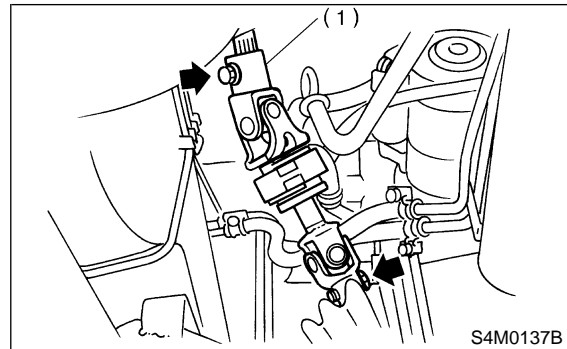

- (1) Universal joint

- 4) Connect tie-rod end and knuckle arm, and tighten with castle nut. Fit cotter pin into the nut and bend the pin to lock.

Castle nut tightening torque:

$27.0 \pm 2.5 \text{ N}\cdot\text{m}$ ($2.75 \pm 0.25 \text{ kg}\cdot\text{m}$, $19.9 \pm 1.8 \text{ ft}\cdot\text{lb}$), and tighten further within 60° until cotter pin hole is aligned with a slot in the nut.

CAUTION:

When connecting, do not hit cap at the bottom of tie-rod end with hammer.

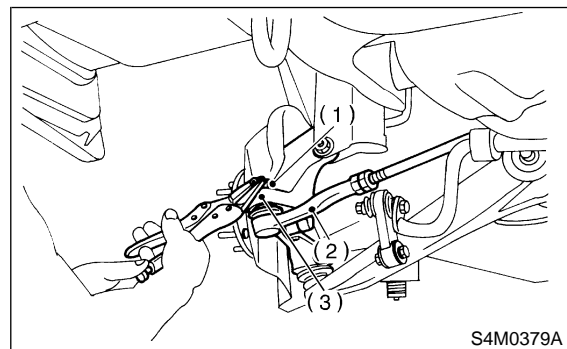

- (1) Castle nut
(2) Tie-rod end
(3) Knuckle arm

- 5) Install front stabilizer to vehicle.
6) Install front exhaust pipe assembly.
<Ref. to 2-9 [W1B0].>
7) Install tires.
8) Tighten wheel nuts to the specified torque.

Tightening torque:

$88 \pm 10 \text{ N}\cdot\text{m}$ ($9.0 \pm 1.0 \text{ kg}\cdot\text{m}$, $65 \pm 7 \text{ ft}\cdot\text{lb}$)

- 9) Connect ground cable to battery.
10) Pour fluid into oil tank, and bleed air.
<Ref. to 4-3 [W7A0].>
11) Check for fluid leaks.

3. Steering Gearbox (Power Steering System)

12) Install jack-up plate.

WARNING:

Be careful, exhaust manifold is hot.

13) Lower vehicle.

14) Check fluid level in oil tank.

15) After adjusting toe-in and steering angle, tighten lock nut on tie-rod end.

Tightening torque:

$83 \pm 5 \text{ N}\cdot\text{m}$ ($8.5 \pm 0.5 \text{ kg}\cdot\text{m}$, $61.5 \pm 3.6 \text{ ft}\cdot\text{lb}$)

CAUTION:

When adjusting toe-in, hold boot as shown to prevent it from being rotated or twisted. If twisted, straighten it.

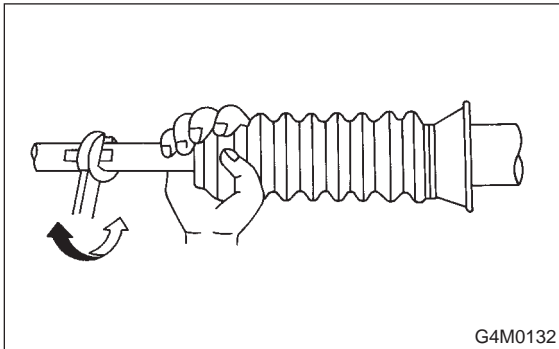

G4M0132

F: ADJUSTMENT

1) Adjust front toe.

Standard of front toe:

$\text{IN } 3 - \text{OUT } 3 \text{ mm}$ ($\text{IN } 0.12 - \text{OUT } 0.12 \text{ in}$)

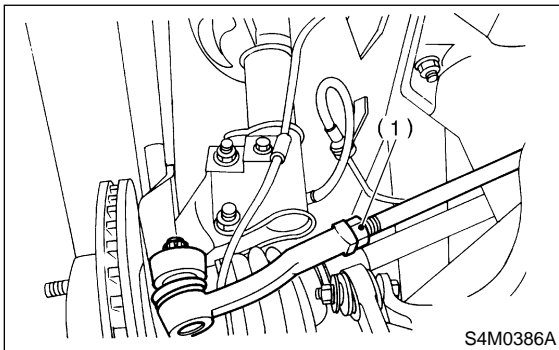

S4M0386A

(1) Lock nut

2) Adjust steering angle of wheels.

Inner wheel: $34.4 \pm 1.5^\circ$

Outer wheel: $30.2 \pm 1.5^\circ$

3) If steering wheel spokes are not horizontal when wheels are set in the straight ahead position, and error is more than 5° on the periphery of steering wheel, correctly re-install the steering wheel.

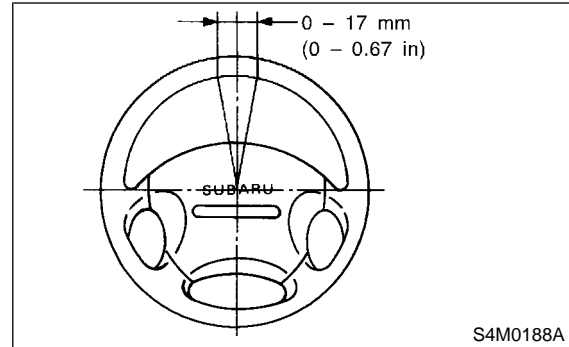

S4M0188A

4) If steering wheel spokes are not horizontal with vehicle set in the straight ahead position after this adjustment, correct it by turning the right and left tie-rods in the same direction by the same turns.

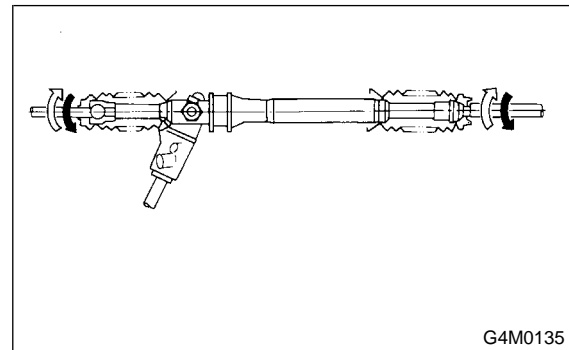

G4M0135