

1. Precaution

A: SUPPLEMENTAL RESTRAINT SYSTEM "AIRBAG"

Airbag system wiring harness is routed near the transmission control module (TCM).

CAUTION:

- All airbag system wiring harness and connectors are yellow. Do not use electrical test equipment on these circuit.
- Be careful not to damage airbag system wiring harness when performing diagnostics and servicing the TCM.

B: MEASUREMENT

When measuring voltage and resistance of the ECM, TCM or each sensor, use a tapered pin with a diameter of less than 0.64 mm (0.025 in) in order to avoid poor contact. Do not insert the pin more than 5 mm (0.20 in).

2. Pre-inspection

A: ATF LEVEL

Make sure that ATF level is in the specification.

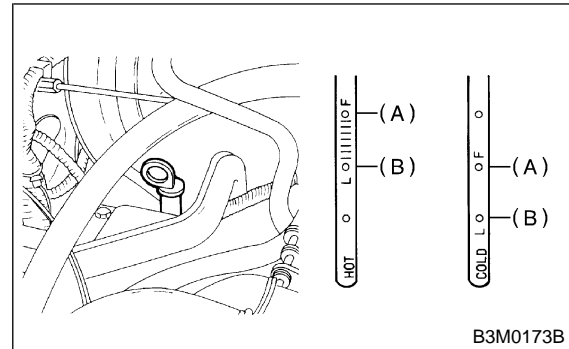

- (A) Upper level
- (B) Lower level

B: FRONT DIFFERENTIAL OIL LEVEL

Make sure that front differential oil level is in the specification.

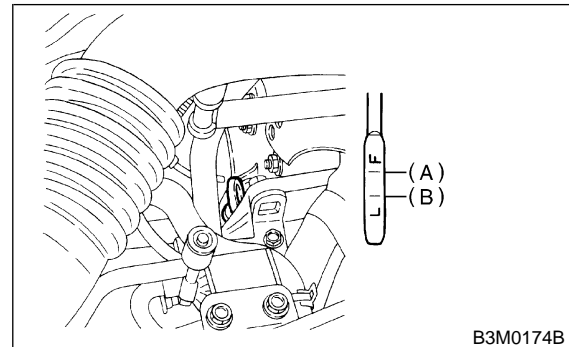

- (A) Upper level
- (B) Lower level