

8. Diagnostic Chart with Trouble Code

A: LIST OF TROUBLE CODE

1. TROUBLE CODE

Trouble code	Item	Content of diagnosis	Title index No.
11	Engine speed signal	Detects open or shorted input signal circuit.	<Ref. to 3-2 [T8C0].>
27	ATF temperature sensor	Detects open or shorted input signal circuit.	<Ref. to 3-2 [T8D0].>
31	Throttle position sensor	Detects open or shorted input signal circuit.	<Ref. to 3-2 [T8E0].>
33	Vehicle speed sensor 2 (Front)	Detects open or shorted input signal circuit.	<Ref. to 3-2 [T8F0].>
36	Torque converter turbine speed sensor	Detects open or shorted input signal circuit.	<Ref. to 3-2 [T8G0].>
38	Torque control signal	Detects open or shorted input signal circuit.	<Ref. to 3-2 [T8H0].>
45	Intake manifold pressure signal	Detects open or shorted input signal circuit.	<Ref. to 3-2 [T8I0].>
71	Shift solenoid 1	Detects open or shorted output signal circuit.	<Ref. to 3-2 [T8J0].>
72	Shift solenoid 2	Detects open or shorted output signal circuit.	<Ref. to 3-2 [T8K0].>
73	Low clutch timing solenoid	Detects open or shorted output signal circuit.	<Ref. to 3-2 [T8L0].>
74	2-4 brake timing solenoid	Detects open or shorted output signal circuit.	<Ref. to 3-2 [T8M0].>
75	Line pressure duty solenoid	Detects open or shorted output signal circuit.	<Ref. to 3-2 [T8N0].>
76	2-4 brake duty solenoid	Detects open or shorted output signal circuit.	<Ref. to 3-2 [T8O0].>
77	Lock-up duty solenoid	Detects open or shorted output signal circuit.	<Ref. to 3-2 [T8P0].>
79	Transfer duty solenoid	Detects open or shorted output signal circuit.	<Ref. to 3-2 [T8Q0].>
93	Vehicle speed sensor 1 (Rear)	Detects open or shorted input signal circuit.	<Ref. to 3-2 [T8R0].>

2. HOW TO READ TROUBLE CODE OF INDICATOR LIGHT

The AT OIL TEMP indicator light flashes the code corresponding to the faulty part.

The long segment (1.2 sec on) indicates a "ten", and the short segment (0.2 sec on) signifies a "one".

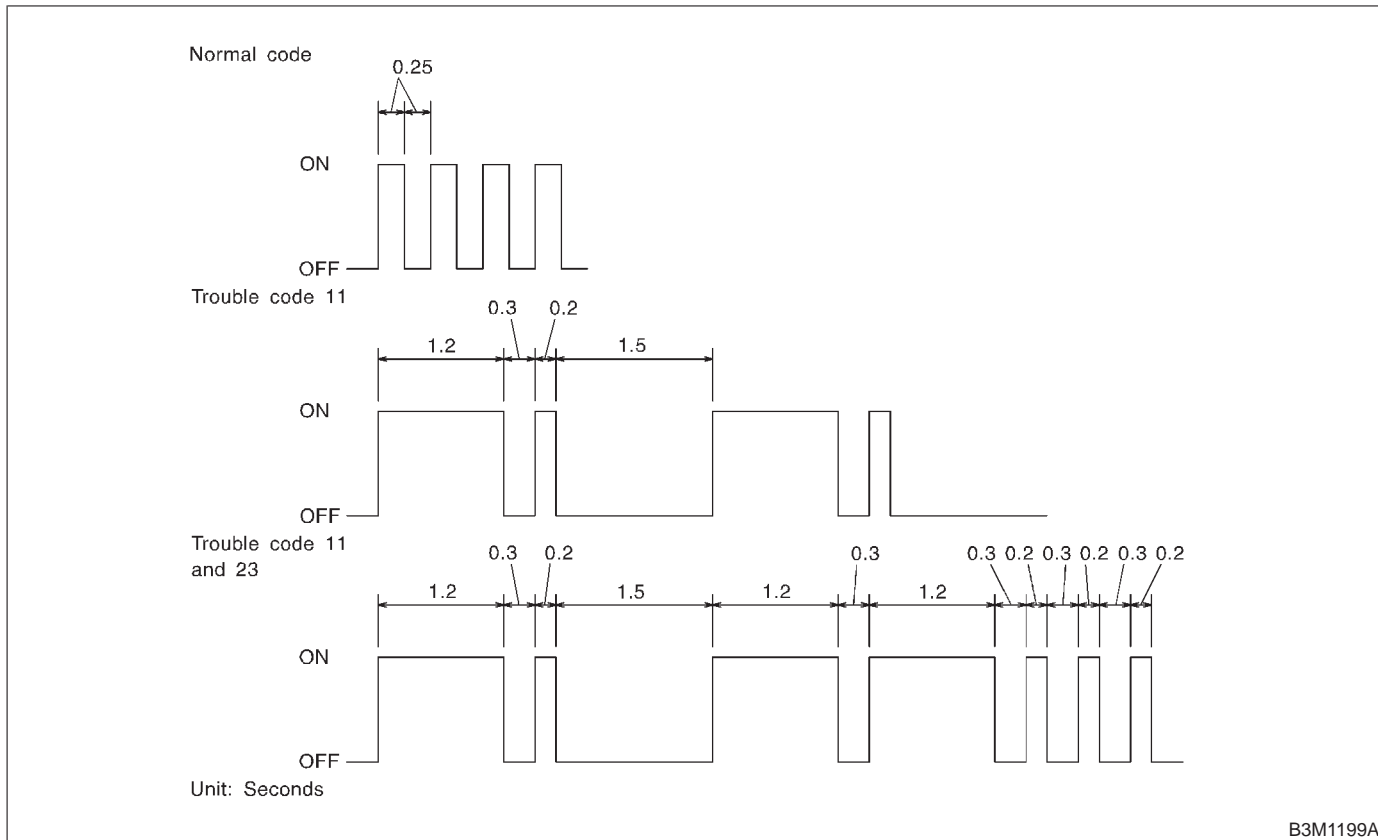

B: CLEAR MEMORY

Current trouble codes shown on the display are cleared by turning the ignition switch OFF after conducting on-board diagnostics operation. Previous trouble codes, however, cannot be cleared since they are stored in the TCM memory which is operating on the back-up power supply. These trouble codes can be cleared by removing the specified fuse (located under the light or left lower position of the instrument panel).

CLEAR MEMORY:

Removal of No. 4 fuse (for at least one minute)

- The No. 4 fuse is located in the line to the memory back-up power supply of the TCM. Removal of this fuse clears the previous trouble codes stored in the TCM memory.
- Be sure to remove the No. 4 fuse for at least the specified length of time. Otherwise, trouble codes may not be cleared.

MEMO:

C: TROUBLE CODE 11 — ENGINE SPEED SIGNAL —

DIAGNOSIS:

Engine speed input signal circuit is open or shorted.

TROUBLE SYMPTOM:

- No lock-up (after engine warm-up).
- AT OIL TEMP indicator remains on when vehicle speed is "0".

WIRING DIAGRAM:

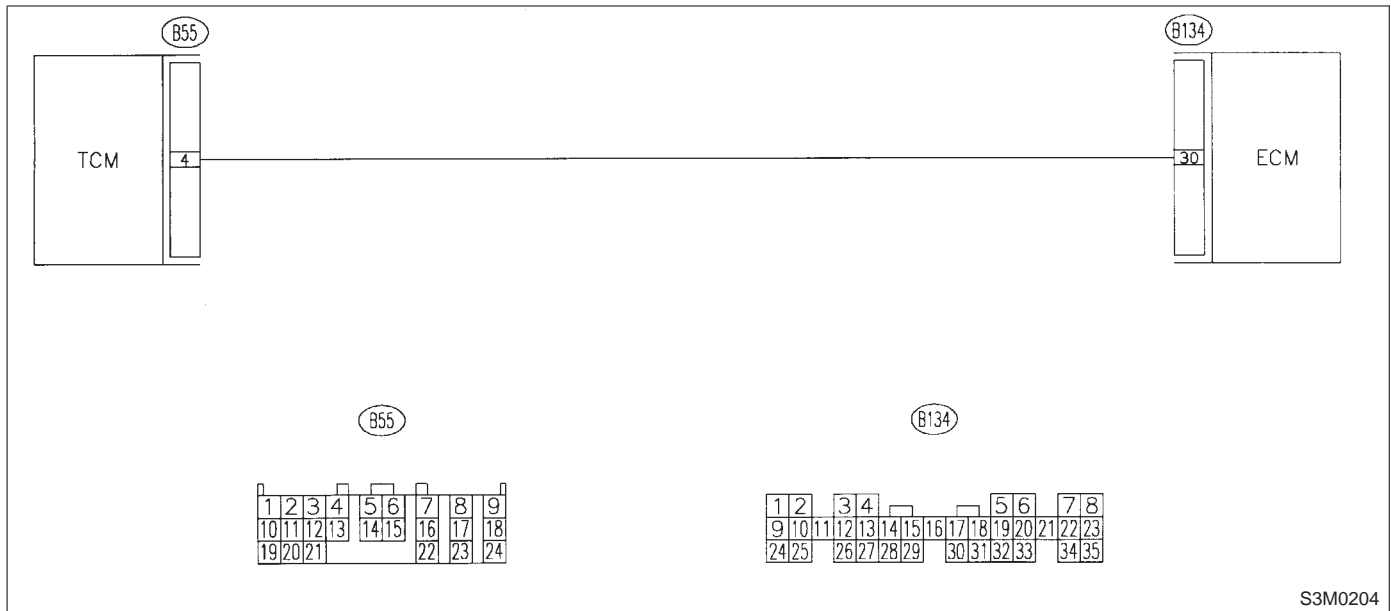

8C1 : CHECK HARNESS CONNECTOR BETWEEN TCM AND ECM.

- 1) Turn ignition switch to OFF.
- 2) Measure resistance of harness between TCM and ECM connector.

Connector & terminal

(B55) No. 4 — (B134) No. 30:

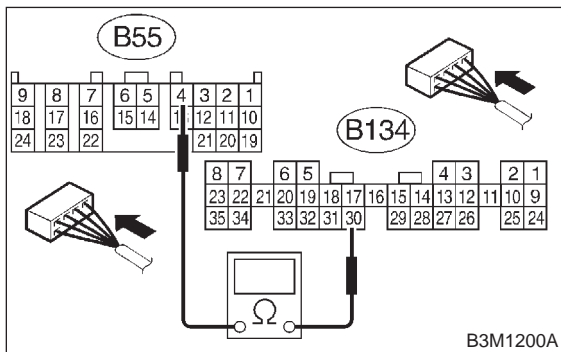

- CHECK** : Is the resistance less than 1 Ω?
- YES** : Go to step **8C2**.
- NO** : Repair open circuit in harness between TCM and ECM connector.

8C2 : CHECK HARNESS CONNECTOR BETWEEN TCM AND ECM.

Measure resistance of harness between TCM connector and chassis ground.

Connector & terminal

(B55) No. 4 — Chassis ground:

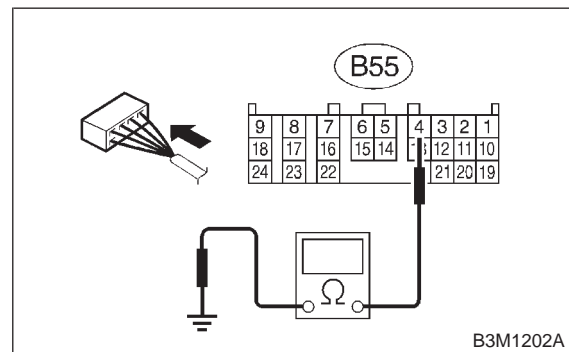

- CHECK** : Is the resistance more than 1 MΩ?
- YES** : Go to step **8C3**.
- NO** : Repair short circuit in harness between TCM and ECM connector.

8C3 : PREPARE SUBARU SELECT MONITOR.

CHECK : *Do you have a Subaru Select Monitor?*

YES : Go to step **8C5**.

NO : Go to step **8C4**.

8C4 : CHECK INPUT SIGNAL FOR TCM.

- 1) Turn ignition switch to ON (engine OFF).
- 2) Measure voltage between TCM connector and chassis ground.

Connector & terminal

(B55) No. 4 (+) — Chassis ground (-):

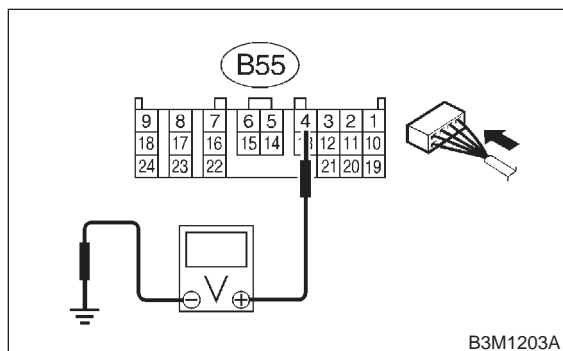

CHECK : *Is the voltage more than 10.5 V?*

YES : Even if "AT OIL TEMP" lights up, the circuit has returned to a normal condition at this time. A temporary poor contact of the connector or harness may be the cause. Repair harness or connector in the TCM and ECM.

NO : Go to step **8C6**.

8C5 : CHECK INPUT SIGNAL FOR TCM USING SUBARU SELECT MONITOR.

- 1) Connect Subaru Select Monitor to data link connector.

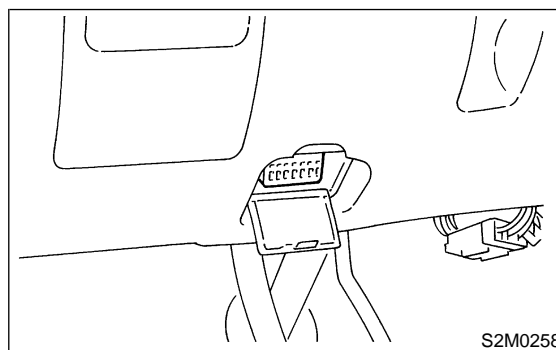

- 2) Start the engine, and turn Subaru Select Monitor switch to ON.
- 3) Warm-up the engine until engine coolant temperature is above 80°C (176°F).
- 4) Engine idling.
- 5) Read data of engine speed using Subaru Select Monitor.
 - Display shows engine speed signal value sent from ECM.

CHECK : *Is the revolution value the same as the tachometer reading shown on the combination meter?*

YES : Even if "AT OIL TEMP" lights up, the circuit has returned to a normal condition at this time. A temporary poor contact of the connector or harness may be the cause. Repair harness or connector in the TCM and ECM.

NO : Go to step **8C6**.

8C6 : CHECK POOR CONTACT.

CHECK : *Is there poor contact in engine speed signal circuit?*

YES : Repair poor contact.

NO : Go to step **8C7**.

8C7 : CONFIRM TROUBLE CODE 11.

CHECK : *Replace ECM with a new one. Does the trouble code appear again, after the memory has been cleared?*

YES : Replace TCM. <Ref. to 3-2 [W23A0].>

NO : Replace ECM. <Ref. to 2-7 [W17A0].>

D: TROUBLE CODE 27 — ATF TEMPERATURE SENSOR —

DIAGNOSIS:

Input signal circuit of TCM to ATF temperature sensor is open or shorted.

TROUBLE SYMPTOM:

Excessive shift shock.

WIRING DIAGRAM:

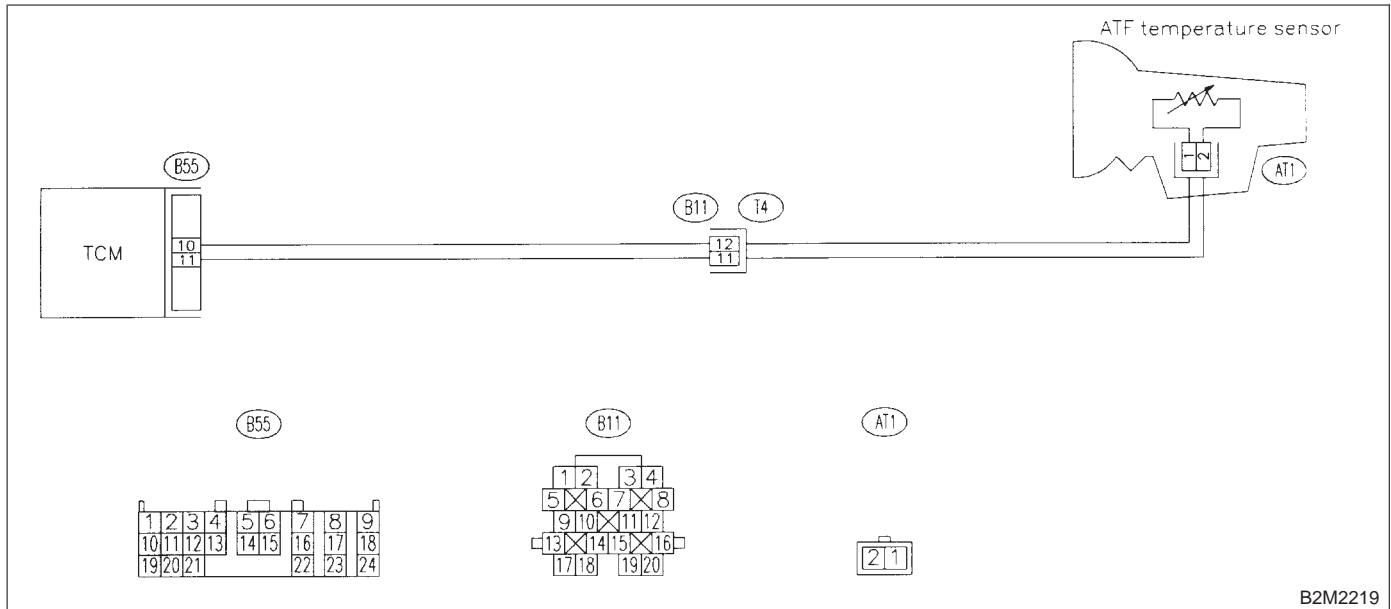

B2M2219

8D1 : CHECK HARNESS CONNECTOR BETWEEN TCM AND ATF TEMPERATURE SENSOR.

- 1) Turn ignition switch to OFF.
- 2) Disconnect connector from transmission.
- 3) Measure resistance of harness between TCM and transmission connector.

Connector & terminal

(B55) No. 10 — (B11) No. 12:

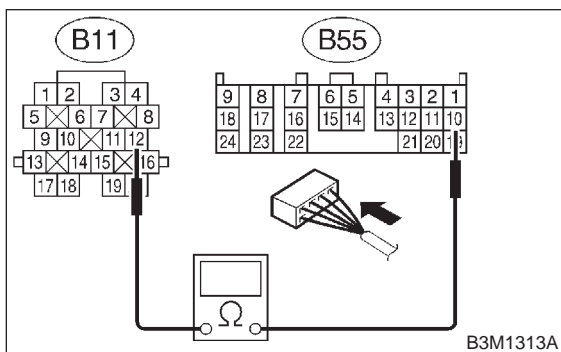

B3M1313A

- CHECK** : *Is the resistance less than 1 Ω?*
- YES** : Go to step **8D2**.
- NO** : Repair open circuit in harness between TCM and transmission connector.

8D2 : CHECK HARNESS CONNECTOR BETWEEN TCM AND ATF TEMPERATURE SENSOR.

Measure resistance of harness between TCM and transmission connector.

Connector & terminal

(B55) No. 11 — (B11) No. 11:

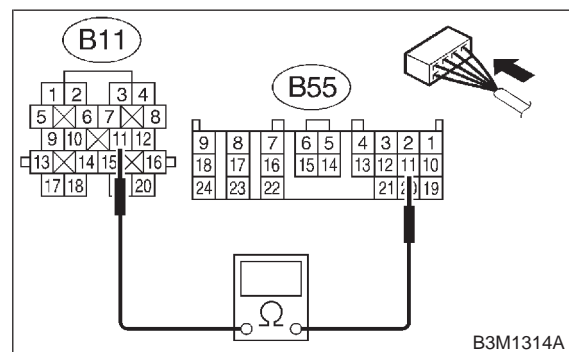

B3M1314A

- CHECK** : *Is the resistance less than 1 Ω?*
- YES** : Go to step **8D3**.
- NO** : Repair open circuit in harness between TCM and transmission connector.

8D3 : CHECK HARNESS CONNECTOR BETWEEN TCM AND ATF TEMPERATURE SENSOR.

Measure resistance of harness between TCM connector and chassis ground.

Connector & terminal

(B55) No. 10 — Chassis ground:

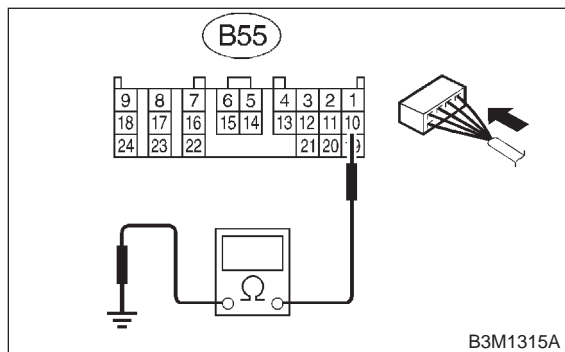

- CHECK** : *Is the resistance more than 1 MΩ?*
- YES** : Go to step **8D4**.
- NO** : Repair short circuit in harness between TCM and transmission connector.

8D4 : CHECK HARNESS CONNECTOR BETWEEN TCM AND ATF TEMPERATURE SENSOR.

Measure resistance of harness between TCM connector and chassis ground.

Connector & terminal

(B55) No. 11 — Chassis ground:

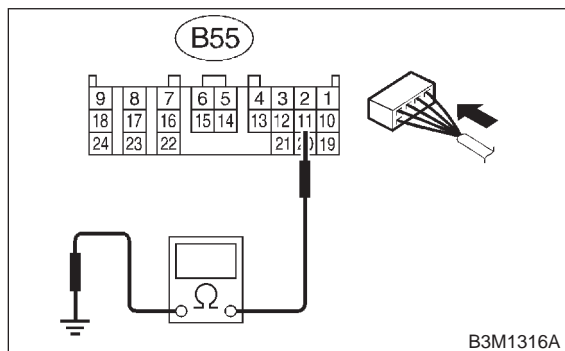

- CHECK** : *Is the resistance more than 1 MΩ?*
- YES** : Go to step **8D5**.
- NO** : Repair short circuit in harness between TCM and transmission connector.

8D5 : CHECK ATF TEMPERATURE SENSOR.

- 1) Turn ignition switch to OFF.
- 2) Connect connectors to transmission.
- 3) Turn ignition switch to ON and start engine.
- 4) Warm-up the transmission until ATF temperature reaches to 80°C (176°F).

NOTE:

If ambient temperature is below 0°C (32°F), drive the vehicle until the ATF reaches its operating temperature.

- 5) Disconnect connector from transmission.
- 6) Measure resistance between transmission connector terminals.

Connector & terminal

(T4) No. 11 — No. 12:

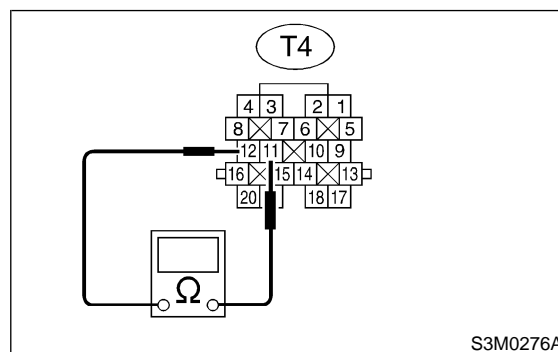

- CHECK** : *Is the resistance between 275 and 375 Ω?*
- YES** : Go to step **8D6**.
- NO** : Go to step **8D13**.

8D6 : CHECK ATF TEMPERATURE SENSOR.

- 1) Turn ignition switch to ON (engine OFF).
- 2) Measure resistance between transmission connector terminals.

Connector & terminal

(T4) No. 11 — No. 12:

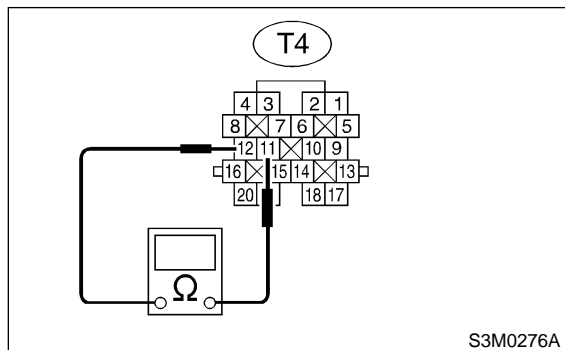

CHECK : *Does the resistance value increase while the ATF temperature decreases?*

YES : Go to step 8D7.

NO : Go to step 8D13.

8D7 : PREPARE SUBARU SELECT MONITOR.

CHECK : *Do you have a Subaru Select Monitor?*

YES : Go to step 8D10.

NO : Go to step 8D8.

8D8 : CHECK INPUT SIGNAL FOR TCM.

- 1) Warm-up the transmission until ATF temperature is about 80°C (176°F).

NOTE:

If ambient temperature is below 0°C (32°F), drive the vehicle until the ATF reaches its operating temperature.

- 2) Measure voltage between TCM connector terminal.

Connector & terminal

(B55) No. 11 (+) — No. 10 (-):

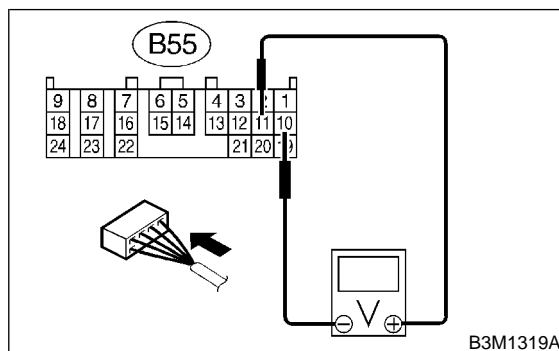

CHECK : *Is the voltage between 0.5 and 0.8 V?*

YES : Go to step 8D9.

NO : Go to step 8D12.

8D9 : CHECK INPUT SIGNAL FOR TCM.

- 1) Cool-down the transmission until ATF temperature is under 20°C (68°F).
- 2) Measure voltage between TCM connector terminal.

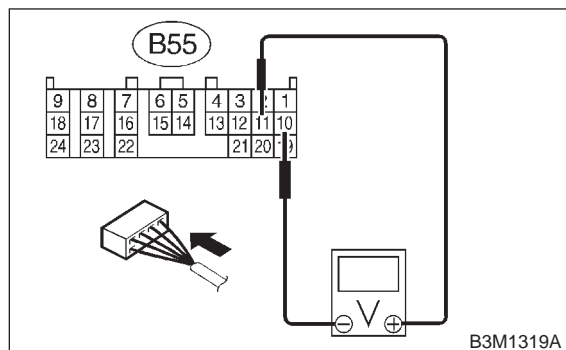
Connector & terminal**(B55) No. 11 (+) — No. 10 (-):****CHECK** : **Is the voltage between 2.9 and 4.9 V?**

YES : Even if "AT OIL TEMP" lights up, the circuit has returned to a normal condition at this time. A temporary poor contact of the connector or harness may be the cause. Repair harness or contact in the ATF temperature sensor or transmission connector.

NO : Go to step **8D12**.

8D10 : CHECK INPUT SIGNAL FOR TCM USING SUBARU SELECT MONITOR.

- 1) Turn ignition switch to OFF.
- 2) Connect connector to transmission.
- 3) Connect Subaru Select Monitor to data link connector.

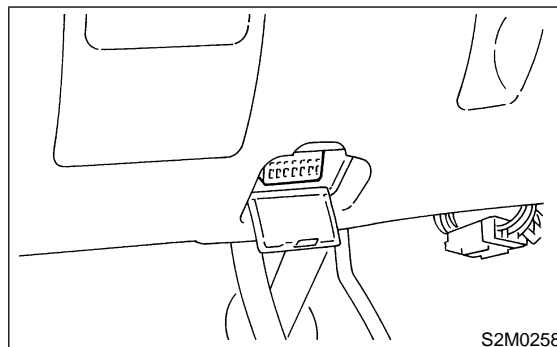

- 4) Start the engine, and turn Subaru Select Monitor switch to ON.
- 5) Warm-up the transmission until ATF temperature is above 80°C (176°F).

NOTE:

If ambient temperature is below 0°C (32°F), drive the vehicle until the ATF reaches its operating temperature.

- 6) Read data of ATF temperature using Subaru Select Monitor.

● ATF temperature is indicated in "°F" or "°C".

CHECK : **Is the ATF temperature between 70 and 110°C (158 and 230°F).**

YES : Go to step **8D11**.

NO : Go to step **8D12**.

8D11 : CHECK INPUT SIGNAL FOR TCM USING SUBARU SELECT MONITOR.

Turn ignition switch to ON (engine OFF).

CHECK : **Does the ATF temperature gradually decrease?**

YES : Even if "AT OIL TEMP" light up, the circuit has returned to a normal condition at this time. A temporary poor contact of the connector or harness may be the case. Repair harness or contact in the ATF temperature sensor and transmission connector.

NO : Go to step **8D12**.

8D12 : CHECK POOR CONTACT.

CHECK : *Is there poor contact in ATF temperature sensor circuit?*

YES : Repair poor contact.

NO : Replace TCM. <Ref. to 3-2 [W23A0].>

8D13 : CHECK HARNESS CONNECTOR BETWEEN TRANSMISSION AND ATF TEMPERATURE SENSOR.

- 1) Turn ignition switch to OFF.
- 2) Disconnect connector from transmission.
- 3) Remove transmission connector from stay.
- 4) Lift-up or raise the vehicle and support with safety stand.

CAUTION:
On AWD models, raise all wheels off ground.

- 5) Drain automatic transmission fluid.

CAUTION:
Do not drain the automatic transmission fluid until it cools down.

- 6) Remove oil pan, and disconnect connector from ATF temperature sensor connector.
- 7) Measure resistance of harness between ATF temperature sensor and transmission connector.

Connector & terminal
(T4) No. 11 — (AT1) No. 2:

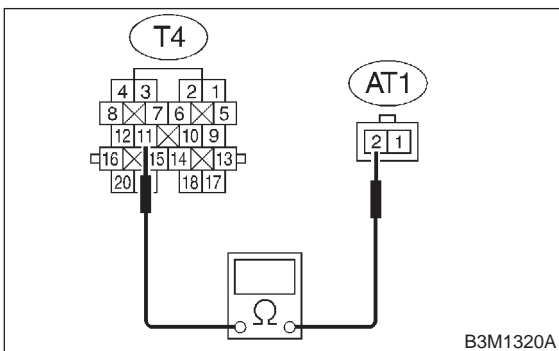

CHECK : *Is the resistance less than 1 Ω?*

YES : Go to step 8D14.

NO : Repair open circuit in harness between ATF temperature sensor and transmission connector.

8D14 : CHECK HARNESS CONNECTOR BETWEEN TRANSMISSION AND ATF TEMPERATURE SENSOR.

Measure resistance of harness between ATF temperature sensor and transmission connector.

Connector & terminal
(T4) No. 12 — (AT1) No. 1:

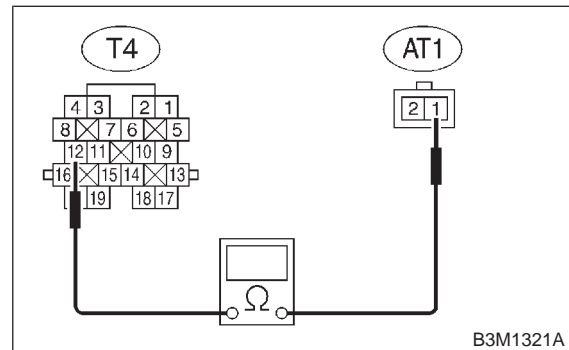

CHECK : *Is the resistance less than 1 Ω?*

YES : Go to step 8D15.

NO : Repair open circuit in harness between ATF temperature sensor and transmission connector.

8D15 : CHECK HARNESS CONNECTOR BETWEEN TRANSMISSION AND ATF TEMPERATURE SENSOR.

Measure resistance of harness between transmission connector and transmission ground.

Connector & terminal
(T4) No. 11 — Transmission ground:

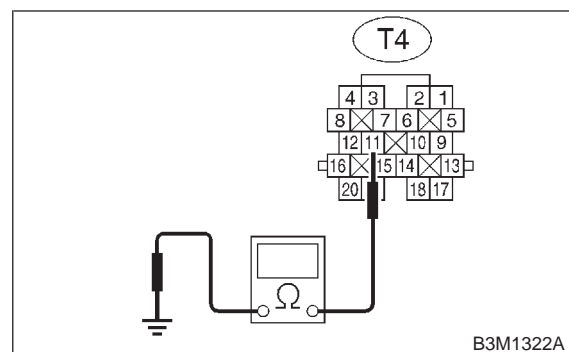

CHECK : *Is the resistance more than 1 MΩ?*

YES : Go to step 8D16.

NO : Repair short circuit in harness between ATF temperature sensor and transmission connector.

8D16 : CHECK HARNESS CONNECTOR BETWEEN TRANSMISSION AND ATF TEMPERATURE SENSOR.

Measure resistance of harness between transmission connector and transmission ground.

Connector & terminal

(T4) No. 12 — Transmission ground:

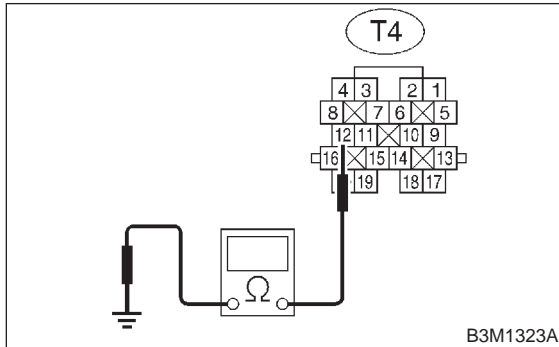

- CHECK** : **Is the resistance more than 1 MΩ?**
- YES** : Replace ATF temperature sensor. <Ref. to 3-2 [W4A0].>
- NO** : Repair short circuit in harness between ATF temperature sensor and transmission connector.

E: TROUBLE CODE 31 — THROTTLE POSITION SENSOR —

DIAGNOSIS:

Input signal circuit of throttle position sensor is open or shorted.

TROUBLE SYMPTOM:

Shift point too high or too low; engine brake not effected in “3” range: excessive shift shock; excessive tight corner “braking”.

WIRING DIAGRAM:

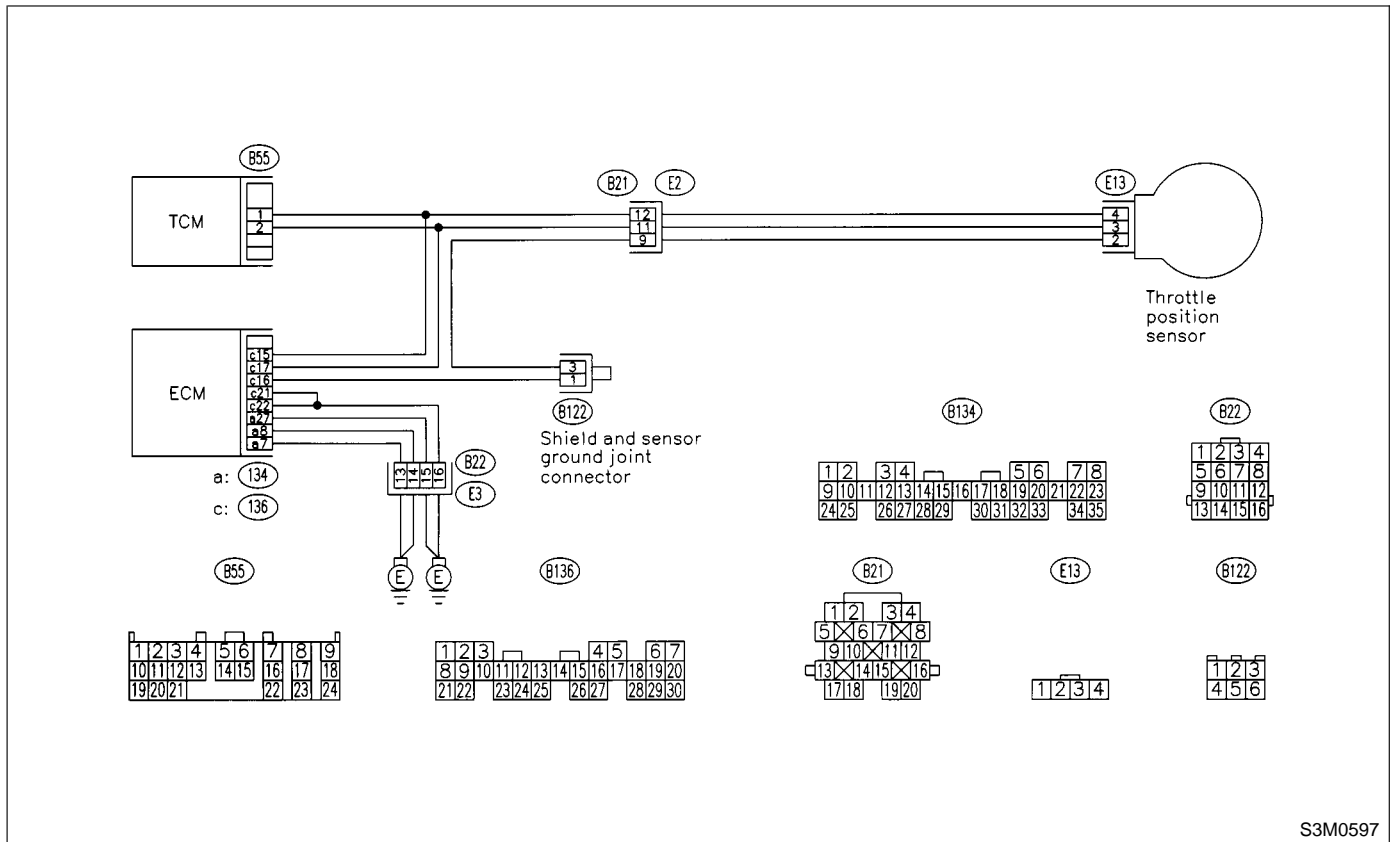

S3M0597

8E1 : CHECK ENGINE GROUND TERMINALS.

- CHECK** : Have engine ground terminals been tightened?
- YES** : Go to step 8E2.
- NO** : Tighten engine ground terminals.

8E2 : CHECK THROTTLE POSITION SENSOR.

- 1) Turn ignition switch to OFF.
- 2) Disconnect connector from throttle position sensor.
- 3) Measure resistance between throttle position sensor connector receptacle's terminals.

Terminals

No. 4 — No. 2:

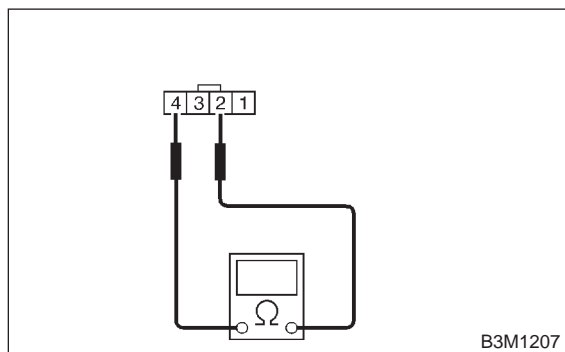

- CHECK** : *Is the resistance between 0.3 and 0.7 kΩ?*
- YES** : Go to step 8E3.
- NO** : Replace throttle position sensor. <Ref. to 2-7 [W10A0].>

8E3 : CHECK THROTTLE POSITION SENSOR.

Measure resistance between throttle position sensor connector receptacle's terminals.

Terminals

No. 2 — No. 3:

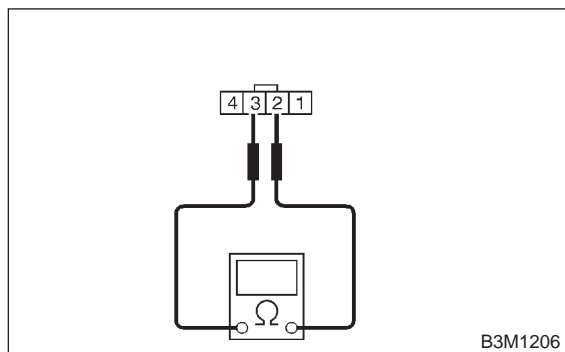

- CHECK** : *Is the resistance between 3.5 and 6.5 kΩ?*
- YES** : Go to step 8E4.
- NO** : Replace throttle position sensor. <Ref. to 2-7 [W10A0].>

8E4 : CHECK HARNESS CONNECTOR BETWEEN TCM AND THROTTLE POSITION SENSOR.

Measure resistance of harness between TCM and throttle position sensor connector.

Connector & terminal

(B55) No. 2 — (E13) No. 3:

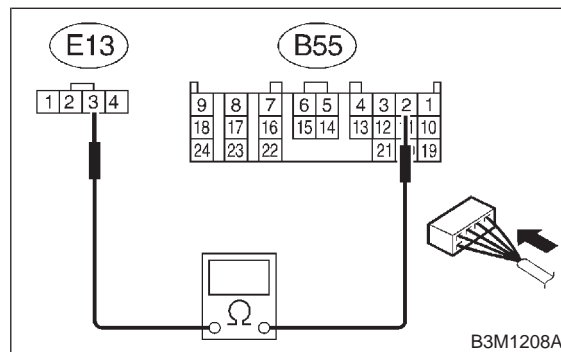

- CHECK** : *Is the resistance less than 1 Ω?*
- YES** : Go to step 8E5.
- NO** : Repair open circuit in harness between TCM and throttle position sensor connector.

8E5 : CHECK HARNESS CONNECTOR BETWEEN TCM AND THROTTLE POSITION SENSOR.

Measure resistance of harness between TCM and throttle position sensor connector.

Connector & terminal

(B55) No. 1 — (E13) No. 4:

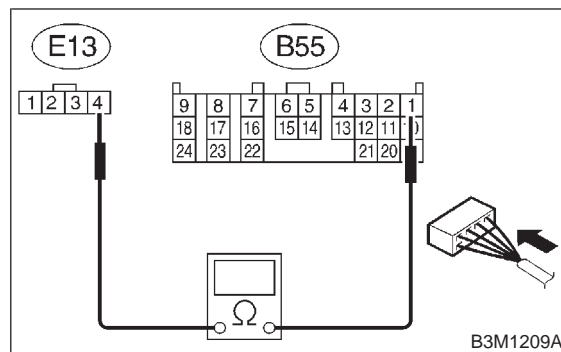

- CHECK** : *Is the resistance less than 1 Ω?*
- YES** : Go to step 8E6.
- NO** : Repair open circuit in harness between TCM and throttle position sensor connector.

8E6 : CHECK HARNESS CONNECTOR BETWEEN TCM AND THROTTLE POSITION SENSOR.

Measure resistance of harness between TCM connector and chassis ground.

Connector & terminal

(B55) No. 2 — Chassis ground:

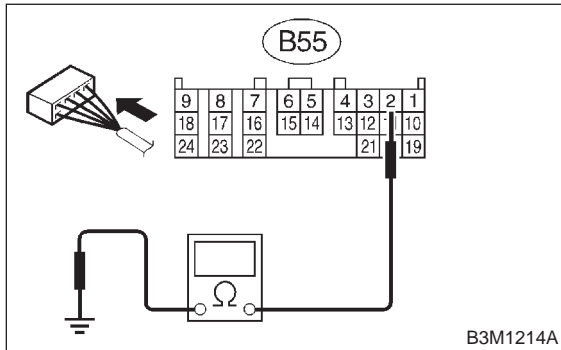

CHECK : *Is the resistance more than 1 MΩ?*

YES : Go to step 8E7.

NO : Repair short circuit in harness between TCM and throttle position sensor connector.

8E7 : CHECK HARNESS CONNECTOR BETWEEN TCM AND THROTTLE POSITION SENSOR.

Measure resistance of harness between TCM connector and chassis ground.

Connector & terminal

(B55) No. 1 — Chassis ground:

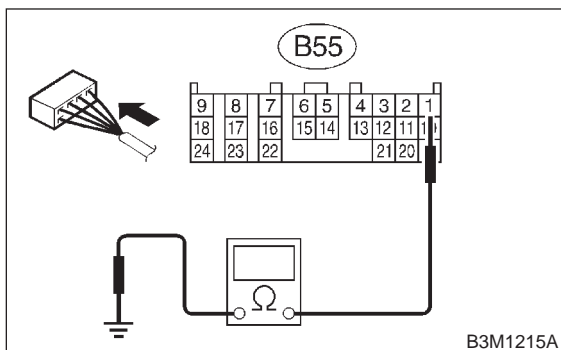

CHECK : *Is the resistance more than 1 MΩ?*

YES : Go to step 8E8.

NO : Repair short circuit in harness between TCM and throttle position sensor connector.

8E8 : PREPARE SUBARU SELECT MONITOR.

CHECK : *Do you have a Subaru Select Monitor?*

YES : Go to step 8E11.

NO : Go to step 8E9.

8E9 : CHECK INPUT SIGNAL FOR TCM.

- 1) Connect connector to throttle position sensor.
- 2) Turn ignition switch to ON (engine OFF).
- 3) Measure voltage between TCM connector terminals.

Connector & terminal

(B55) No. 2 (+) — No. 9 (-):

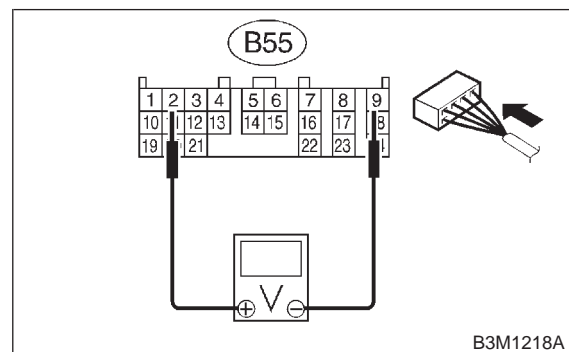

CHECK : *Is the voltage between 0.3 and 0.7 V in throttle fully closed?*

YES : Go to step 8E10.

NO : Go to step 8E15.

8E10 : CHECK INPUT SIGNAL FOR TCM.

Measure voltage between TCM connector terminals.

Connector & terminal

(B55) No. 2 (+) — No. 9 (-):

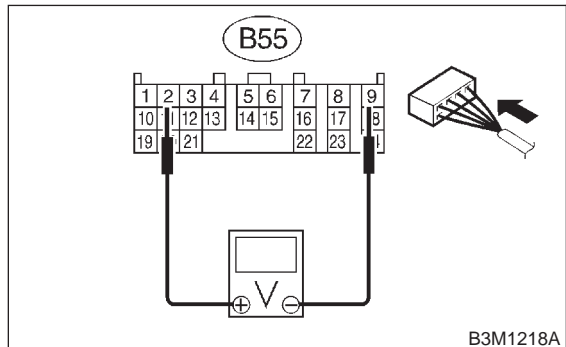

CHECK : *Is the voltage between 4.3 and 4.9 V with throttle fully open?*

YES : Go to step 8E13.

NO : Go to step 8E15.

8E11 : CHECK INPUT SIGNAL FOR TCM USING SUBARU SELECT MONITOR.

- 1) Connect connectors to throttle position sensor.
- 2) Connect Subaru Select Monitor to data link connector.

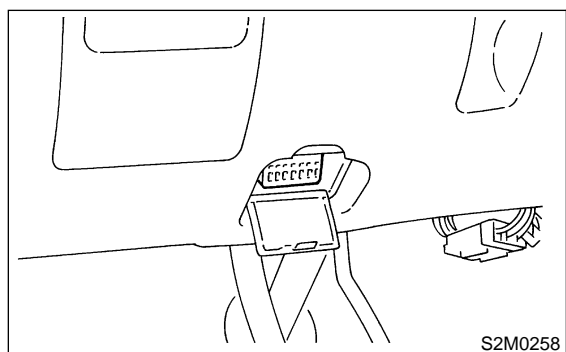

- 3) Turn ignition switch to ON (engine OFF).
 - 4) Turn Subaru Select Monitor switch to ON.
 - 5) Throttle fully closed.
 - 6) Read data of throttle position sensor using Subaru Select Monitor.
- Throttle position sensor input signal is indicated.

CHECK : *Is the value voltage between 0.3 and 0.7 V?*

YES : Go to step 8E12.

NO : Go to step 8E15.

8E12 : CHECK INPUT SIGNAL FOR TCM USING SUBARU SELECT MONITOR.

Throttle fully open.

NOTE:

Must be changed correspondingly with accelerator pedal operation (from “released” to “depressed” position).

CHECK : *Is the value voltage between 4.3 and 4.9 V?*

YES : Go to step 8E14.

NO : Go to step 8E15.

8E13 : CHECK INPUT SIGNAL FOR TCM (THROTTLE POSITION SENSOR POWER SUPPLY).

Measure voltage between TCM connector and chassis ground.

Connector & terminal

(B55) No. 1 (+) — Chassis ground (-):

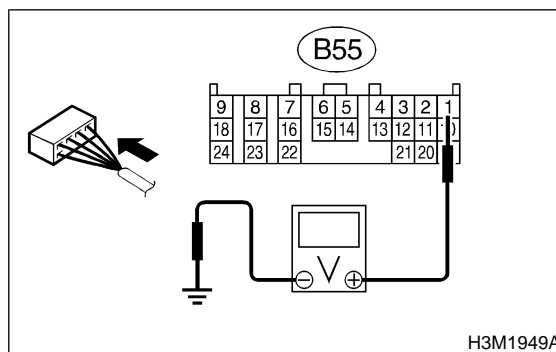

CHECK : *Is the voltage between 4.8 and 5.3 V?*

YES : Even if “AT OIL TEMP” lights up, the circuit has returned to a normal condition at this time. A temporary poor contact of the connector or harness may be the cause. Repair harness or connector in throttle position sensor circuit.

NO : Go to step 8E15.

8E14 : CHECK INPUT SIGNAL FOR TCM USING SUBARU SELECT MONITOR (THROTTLE POSITION SENSOR POWER SUPPLY).

Read data of throttle position sensor power supply using Subaru Select Monitor.

● Throttle position sensor power supply voltage is indicated.

CHECK : *Is the value voltage between 4.8 and 5.3 V?*

YES : Even if "AT OIL TEMP" lights up, the circuit has returned to a normal condition at this time. A temporary poor contact of the connector or harness may be the cause. Repair harness or connector in throttle position sensor circuit.

NO : Go to step **8E15**.

8E15 : CHECK POOR CONTACT.

CHECK : *Is there poor contact in throttle position sensor circuit?*

YES : Repair poor contact.

NO : Replace TCM. <Ref. to 3-2 [W23A0].>

MEMO:

F: TROUBLE CODE 33 — VEHICLE SPEED SENSOR 2 (FRONT) —

DIAGNOSIS:

- The vehicle speed signal is abnormal.
- The circuit in combination meter is faulty.
- The harness connector between TCM and vehicle speed sensor is in short or open.

TROUBLE SYMPTOM:

- Erroneous idling.
- Engine stalls.
- Poor driving performance.

WIRING DIAGRAM:

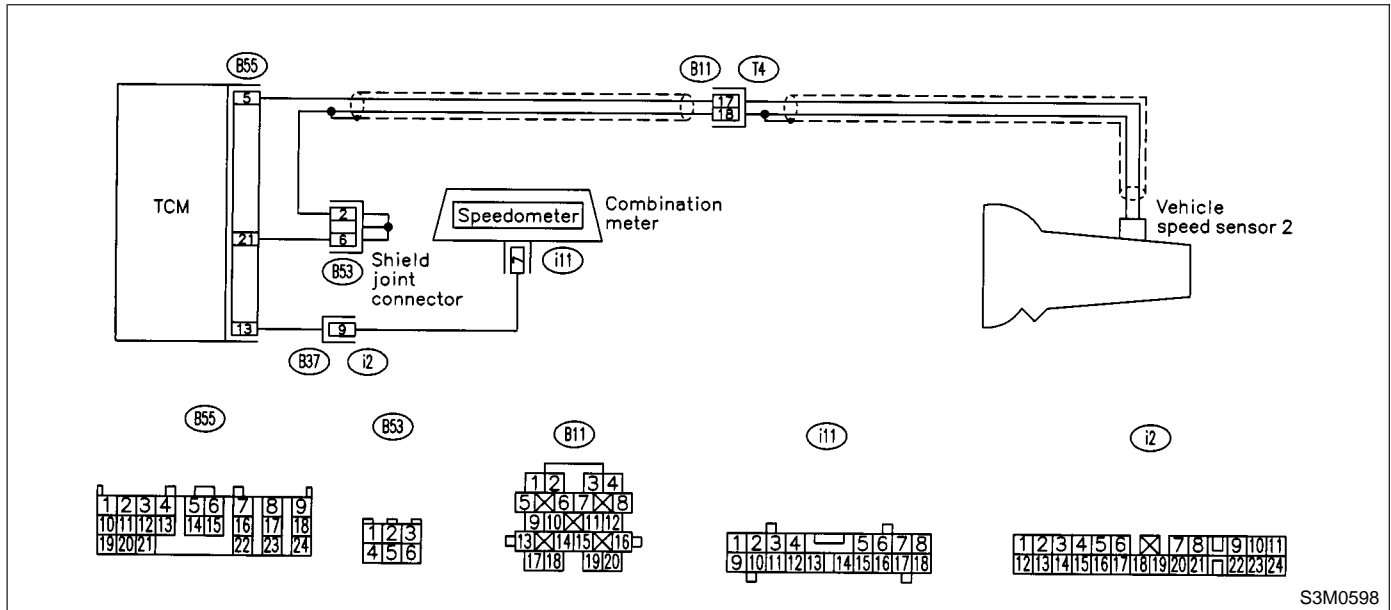

S3M0598

8F1 : CHECK OPERATION OF SPEEDOMETER.

- CHECK** : *Does speedometer operate normally?*
- YES** : Even if "AT OIL TEMP" lights up, the circuit has returned to a normal condition at this time. A temporary poor contact of the connector or harness may be the cause. Repair harness or connector in the TCM and transmission.
- NO** : Go to step **8F2**.

8F2 : CHECK HARNESS CONNECTOR BETWEEN TCM AND TRANSMISSION.

- 1) Disconnect connector from transmission.
- 2) Measure resistance of harness between TCM and transmission connector.

Connector & terminal
(B55) No. 5 — (B11) No. 17:

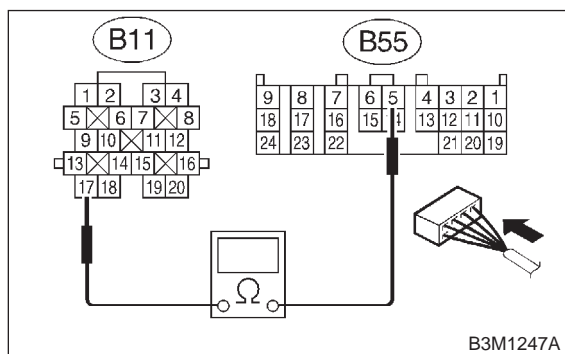

- CHECK** : *Is the resistance less than 1 Ω?*
- YES** : Go to step 8F3.
- NO** : Repair open circuit in harness between TCM and transmission connector.

8F3 : CHECK HARNESS CONNECTOR BETWEEN TCM AND TRANSMISSION.

Measure resistance of harness between TCM and transmission connector.

Connector & terminal
(B55) No. 21 — (B11) No. 18:

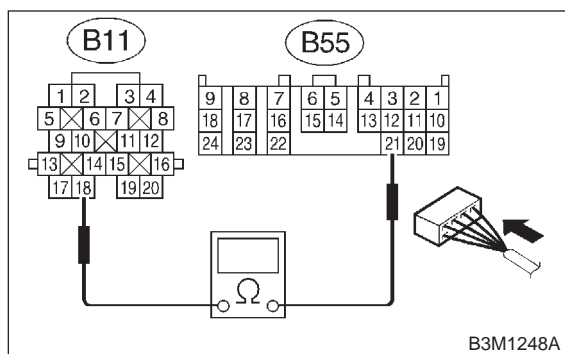

- CHECK** : *Is the resistance less than 1 Ω?*
- YES** : Go to step 8F4.
- NO** : Repair open circuit in harness between TCM and transmission connector, and poor contact in coupling connector.

8F4 : CHECK HARNESS CONNECTOR BETWEEN TCM AND TRANSMISSION.

Measure resistance of harness between TCM and chassis ground.

Connector & terminal
(B55) No. 21 — Chassis ground:

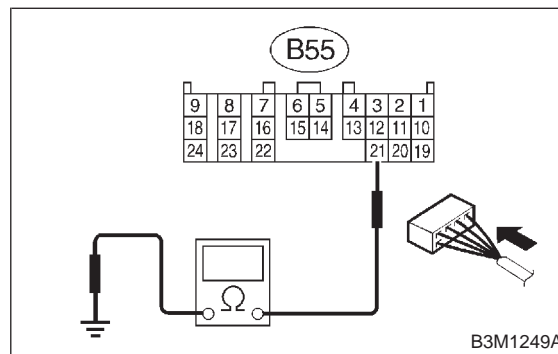

- CHECK** : *Is the resistance more than 1 MΩ?*
- YES** : Go to step 8F5.
- NO** : Repair short circuit in harness between TCM and transmission connector.

8F5 : CHECK HARNESS CONNECTOR BETWEEN TCM AND TRANSMISSION.

Measure resistance of harness between TCM and chassis ground.

Connector & terminal
(B55) No. 5 — Chassis ground:

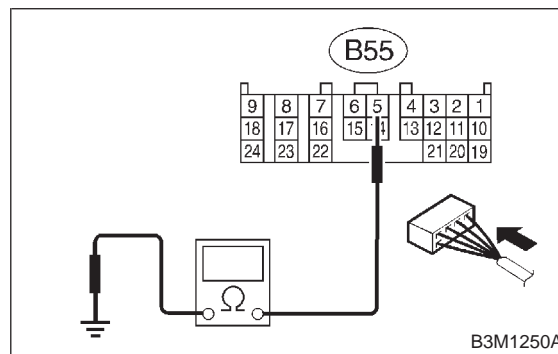

- CHECK** : *Is the resistance more than 1 MΩ?*
- YES** : Go to step 8F6.
- NO** : Repair short circuit in harness between TCM and transmission connector.

8F6 : CHECK VEHICLE SPEED SENSOR 2.

- 1) Turn ignition switch to OFF.
- 2) Disconnect connector from transmission.
- 3) Measure resistance between transmission connector receptacle's terminals.

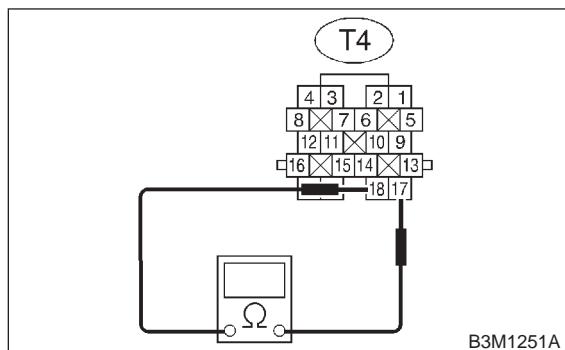
Connector & terminal**(T4) No. 17 — No. 18:**

- CHECK** : Is the resistance between 450 and 650 Ω ?
- YES** : Go to step 8F7.
- NO** : Replace vehicle speed sensor 2. <Ref. to 3-2 [W12B0].>

8F7 : PREPARE OSCILLOSCOPE.

- CHECK** : Do you have oscilloscope?
- YES** : Go to step 8F10.
- NO** : Go to step 8F8.

8F8 : PREPARE SUBARU SELECT MONITOR.

- CHECK** : Do you have a Subaru Select Monitor?
- YES** : Go to step 8F11.
- NO** : Go to step 8F9.

8F9 : CHECK INPUT SIGNAL FOR TCM.

- 1) Connect all connectors.
- 2) Lift-up or raise the vehicle and support with safety stand.

CAUTION:**On AWD models, raise all wheels off ground.**

- 3) Start the engine and set vehicle in 20 km/h (12 MPH) condition.

NOTE:

The speed difference between front and rear wheels may light the ABS warning light, but this indicates no malfunction. When AT control diagnosis is finished, perform the ABS memory clearance procedure of on-board diagnostics system. <Ref. to 4-4 [T6D2].>

- 4) Measure voltage between TCM connector terminals.

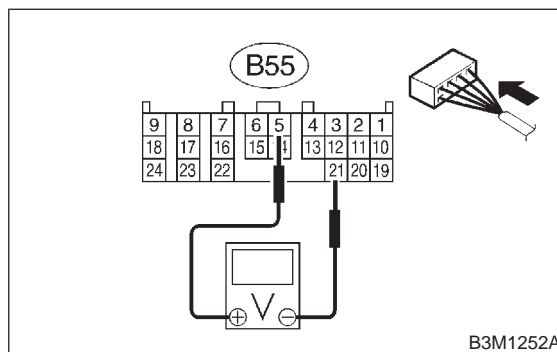
Connector & terminal**(B55) No. 5 (+) — No. 21 (-):**

- CHECK** : Is the voltage more than AC 1 V?
- YES** : Go to step 8F12.
- NO** : Go to step 8F19.

8F10 : CHECK VEHICLE SPEED SENSOR 2 USING OSCILLOSCOPE.

- 1) Connect all connectors.
- 2) Lift-up or raise the vehicle and support with safety stand.

CAUTION:

On AWD models, raise all wheels off ground.

- 3) Set oscilloscope to TCM connector terminals. Positive probe; (B55) No. 5
Earth lead; (B55) No. 21

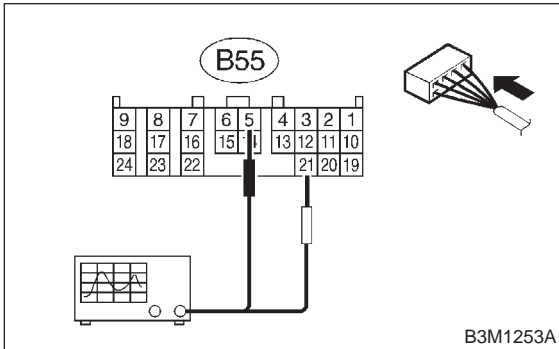

- 4) Start the engine, and drive the wheels slowly.

NOTE:

The speed difference between front and rear wheels may light the ABS warning light, but this indicates no malfunctions. When AT control diagnosis is finished, perform the ABS memory clearance procedure of on-board diagnostics system. <Ref. to 4-4 [T6D2].>

- 5) Measure signal voltage indicated on oscilloscope.

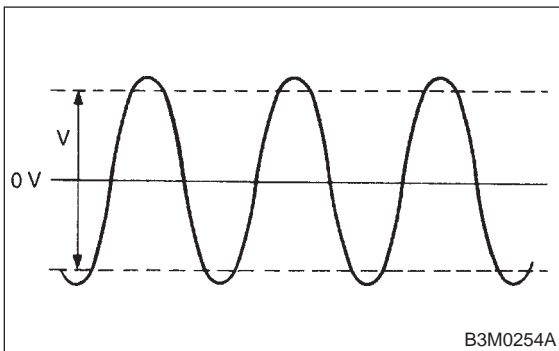

- CHECK** : *Is the voltage more than AC 4 V?*
- YES** : Go to step **8F12**.
- NO** : Go to step **8F19**.

8F11 : CHECK INPUT SIGNAL FOR TCM USING SUBARU SELECT MONITOR.

- 1) Connect all connectors.
- 2) Connect Subaru Select Monitor to data link connector.

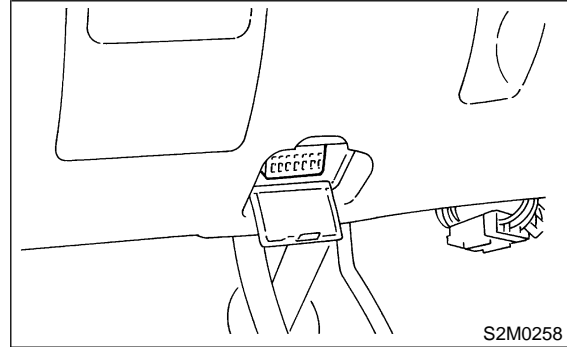

- 3) Lift-up or raise the vehicle and support with safety stand.

CAUTION:

On AWD models, raise all wheels off ground.

- 4) Turn ignition switch to ON and turn Subaru Select Monitor switch to ON.
- 5) Start the engine.
- 6) Read data of vehicle speed using Subaru Select Monitor.
 - Compare speedometer with Subaru Select Monitor indications.
 - Vehicle speed is indicated in "km/h" or "MPH".
- 7) Slowly increase vehicle speed to 60 km/h or 37 MPH.

NOTE:

The speed difference between front and rear wheels may light the ABS warning light, but this indicates no malfunction. When AT control diagnosis is finished, perform the ABS memory clearance procedure of on-board diagnostics system. <Ref. to 4-4 [T6D2].>

- CHECK** : *Does the speedometer indication increase as the Subaru Select Monitor data increases?*
- YES** : Go to step **8F12**.
- NO** : Go to step **8F19**.

8F12 : CHECK HARNESS CONNECTOR BETWEEN TCM AND COMBINATION METER.

- 1) Turn ignition switch to OFF.
- 2) Disconnect connector from combination meter.
- 3) Measure resistance of harness between TCM and combination meter connector.

Connector & terminal
(B55) No. 13 — (i11) No. 7:

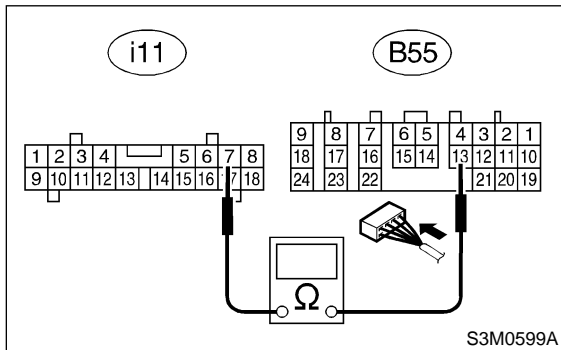

- CHECK** : *Is the resistance less than 1 Ω?*
- YES** : Go to step **8F13**.
- NO** : Repair open circuit in harness between TCM and combination meter connector, and poor contact in coupling connector.

8F13 : CHECK HARNESS CONNECTOR BETWEEN TCM AND COMBINATION METER.

Measure resistance of harness between combination meter and chassis ground.

Connector & terminal
(i11) No. 7 — Chassis ground:

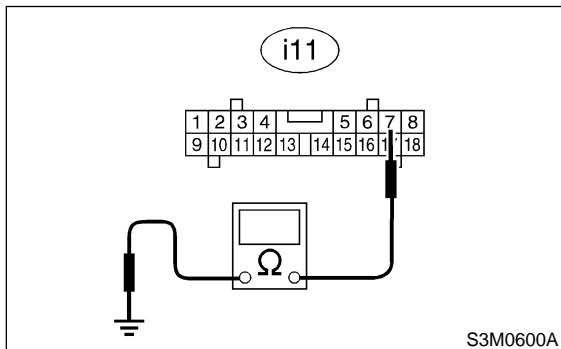

- CHECK** : *Is the resistance more than 1 MΩ?*
- YES** : Go to step **8F14**.
- NO** : Repair short circuit in harness between TCM and combination meter connector.

8F14 : PREPARE OSCILLOSCOPE.

- CHECK** : *Do you have oscilloscope?*
- YES** : Go to step **8F17**.
- NO** : Go to step **8F15**.

8F15 : PREPARE SUBARU SELECT MONITOR.

- CHECK** : *Do you have a Subaru Select Monitor?*
- YES** : Go to step **8F18**.
- NO** : Go to step **8F16**.

8F16 : CHECK OUTPUT SIGNAL FOR TCM.

- 1) Connect all connectors.
- 2) Lift-up or raise the vehicle and support with safety stand.

CAUTION:

On AWD models, raise all wheels off ground.

- 3) Set vehicle in 10 km/h (6 MPH) condition.

NOTE:

The speed difference between front and rear wheels may light ABS warning light, but this indicates no malfunction. When AT control diagnosis is finished, perform the ABS memory clearance procedure on on-board diagnostics system. <Ref. to 4-4 [T6D2].>

- 4) Measure voltage between TCM connector and chassis ground.

Connector & terminal

(B55) No. 13 — Chassis ground:

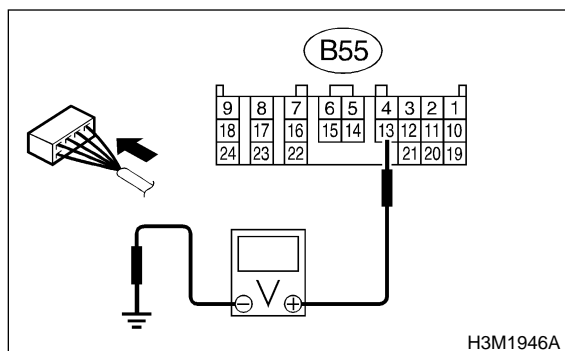

CHECK : **Is the voltage less than 1 V ↔ more than 4 V?**

YES : Even if "AT OIL TEMP" lights up, the circuit has returned to a normal condition at this time. A temporary poor contact of the connector or harness may be the cause. Repair harness or connector in the TCM.

NO : Go to step **8F19**.

8F17 : CHECK INPUT SIGNAL FOR TCM USING OSCILLOSCOPE.

- 1) Connect connectors to combination meter.
- 2) Lift-up or raise the vehicle and support with safety stand.

CAUTION:

On AWD models, raise all wheels off ground.

- 3) Set oscilloscope to TCM connector terminals. Positive probe; (B55) No. 13
Earth lead; (B55) No. 21

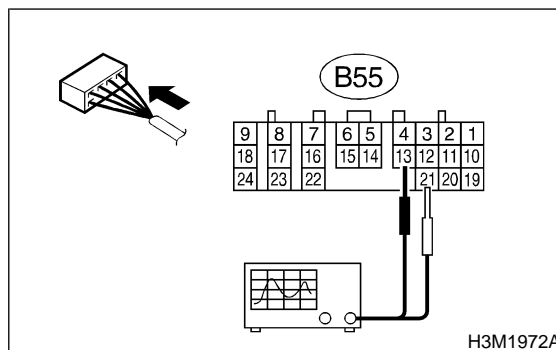

- 4) Start the engine.
- 5) Shift on the gear position, and keep the vehicle speed at constant.
- 6) Measure signal voltage indicated on oscilloscope.

NOTE:

- If vehicle speed increases, the width of amplitude (W) decreases.
- The speed difference between front and rear wheels may light the ABS warning light, but this indicates no malfunction. When AT control diagnosis is finished, perform the ABS memory clearance procedure of on-board diagnostics system. <Ref. to 4-4 [T6D2].>

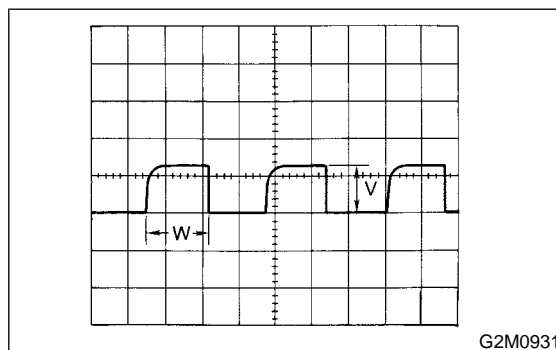

CHECK : **Is the voltage more than AC 2 V?**

YES : Even if "AT OIL TEMP" lights up, the circuit has returned to a normal condition at this time. A temporary poor contact of the connector or harness may be the cause. Repair harness or connector in the TCM.

NO : Go to step **8F19**.

8F18 : CHECK INPUT SIGNAL FOR TCM USING SUBARU SELECT MONITOR.

- 1) Connect all connectors.
- 2) Lift-up or raise the vehicle and support with safety stand.

CAUTION:

On AWD models, raise all wheels off ground.

- 3) Connect Subaru Select Monitor to data link connector.

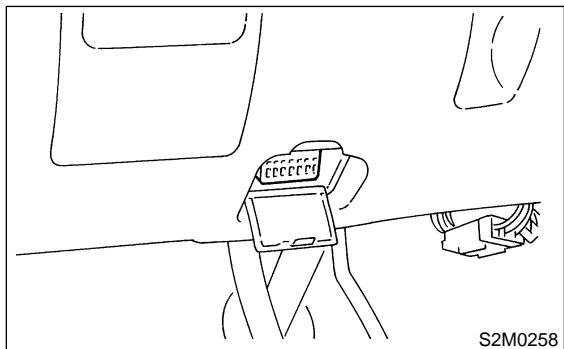

- 4) Turn ignition switch to ON and Subaru Select Monitor switch to ON.
- 5) Start the engine, and drive all wheels.
- 6) Read data of vehicle speed using Subaru Select Monitor.
 - Compare speedometer with Subaru Select Monitor indications.
 - Vehicle speed is indicated in "km/h" or "MPH".
- 7) Slowly increase vehicle speed to 60 km/h or 37 MPH.

NOTE:

The speed difference between front and rear wheels may light the ABS warning light, but this indicates no malfunction. When AT control diagnosis is finished, perform the ABS memory clearance procedure of on-board diagnostics system. <Ref. to 4-4 [T6D2].>

CHECK : ***Does the speedometer indication increase as the Subaru Select Monitor data increases?***

YES : Even if "AT OIL TEMP" lights up, the circuit has returned to a normal condition at this time. A temporary poor contact of the connector or harness may be the cause. Repair harness or connector in the TCM.

NO : Go to step **8F19**.

8F19 : CHECK POOR CONTACT.

CHECK : ***Is there poor contact in vehicle speed sensor 2 circuit?***

YES : Repair poor contact.

NO : Replace TCM. <Ref. to 3-2 [W23A0].>

MEMO:

G: TROUBLE CODE 36 — TORQUE CONVERTER TURBINE SPEED SENSOR

DIAGNOSIS:

Input signal circuit of TCM is open or shorted.

TROUBLE SYMPTOM:

- Excessive shift shock.
- Stuck in 3rd gear when not in low speed (less than 10 km/h or 6 MPH)

WIRING DIAGRAM:

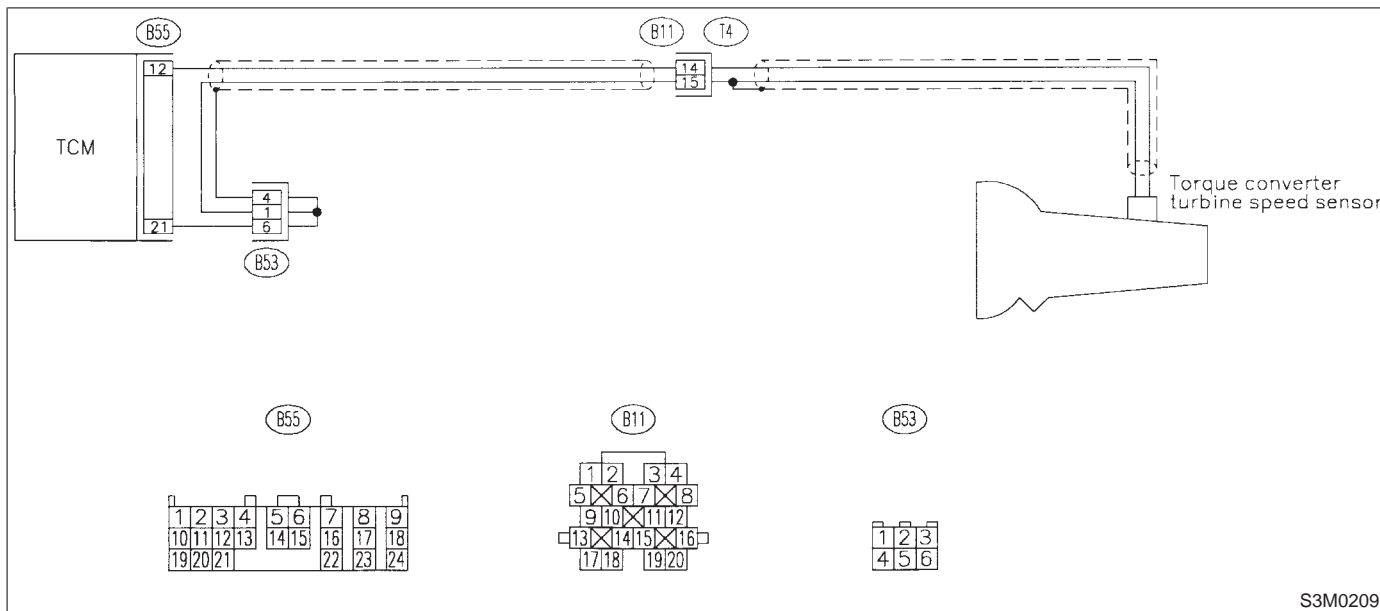

S3M0209

8G1 : CHECK TORQUE CONVERTER TURBINE SPEED SENSOR.

- 1) Turn ignition switch to OFF.
- 2) Disconnect connector from transmission.
- 3) Measure resistance between transmission connector receptacle's terminals.

Connector & terminal
(T4) No. 14 — No. 15:

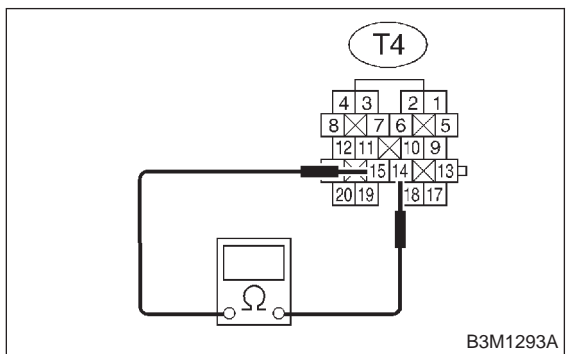

B3M1293A

- CHECK** : Is the resistance between 450 and 650 Ω?
- YES** : Go to step 8G2.
- NO** : Replace torque converter turbine speed sensor. <Ref. to 3-2 [W12A0].>

8G2 : CHECK HARNESS CONNECTOR BETWEEN TCM AND TRANSMISSION.

Measure resistance of harness between TCM and transmission connector.

Connector & terminal
(B55) No. 12 — (B11) No. 14:

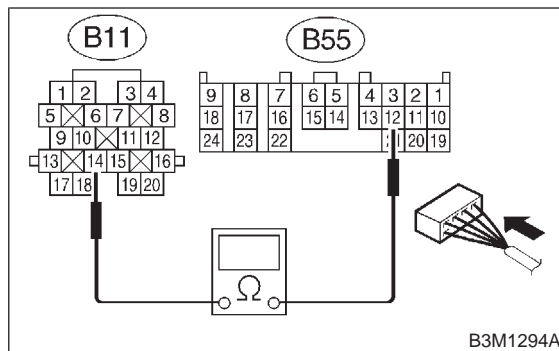

B3M1294A

- CHECK** : Is the resistance less than 1 Ω?
- YES** : Go to step 8G3.
- NO** : Repair open circuit in harness between TCM and transmission connector.

8G3 : CHECK HARNESS CONNECTOR BETWEEN TCM AND TRANSMISSION.

Measure resistance of harness between TCM and transmission connector.

Connector & terminal

(B55) No. 21 — (B11) No. 15:

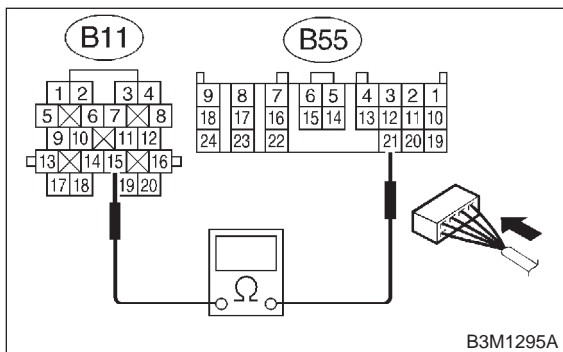

- CHECK** : *Is the resistance less than 1 Ω?*
- YES** : Go to step **8G4**.
- NO** : Repair open circuit in harness between TCM and transmission connector.

8G4 : CHECK HARNESS CONNECTOR BETWEEN TCM AND TRANSMISSION.

Measure resistance of harness between TCM and chassis ground.

Connector & terminal

(B55) No. 21 — Chassis ground:

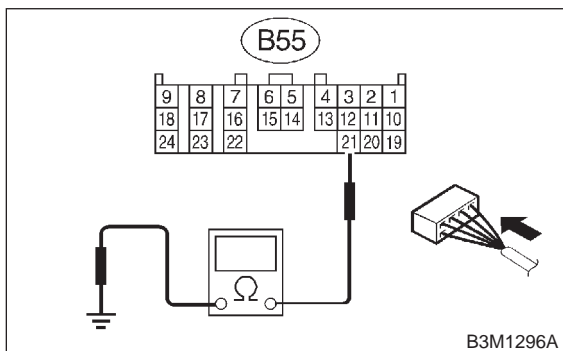

- CHECK** : *Is the resistance more than 1 MΩ?*
- YES** : Go to step **8G5**.
- NO** : Repair short circuit in harness between TCM and transmission connector.

8G5 : CHECK HARNESS CONNECTOR BETWEEN TCM AND TRANSMISSION.

Measure resistance of harness between TCM and chassis ground.

Connector & terminal

(B55) No. 12 — Chassis ground:

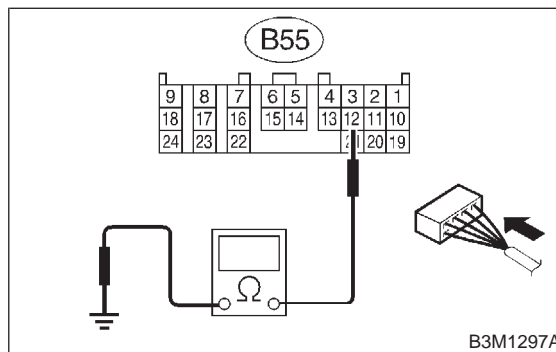

- CHECK** : *Is the resistance more than 1 MΩ?*
- YES** : Go to step **8G6**.
- NO** : Repair short circuit in harness between TCM and transmission connector.

8G6 : PREPARE OSCILLOSCOPE.

- CHECK** : *Do you have oscilloscope?*
- YES** : Go to step **8G10**.
- NO** : Go to step **8G7**.

8G7 : PREPARE SUBARU SELECT MONITOR.

- CHECK** : *Do you have a Subaru Select Monitor?*
- YES** : Go to step **8G9**.
- NO** : Go to step **8G8**.

8G8 : CHECK INPUT SIGNAL FOR TCM.

- 1) Connect connector to transmission.
- 2) Lift-up or raise the vehicle and support with safety stand.

CAUTION:

On AWD models, raise all wheels off ground.

- 3) Start the engine and set vehicle in 20 km/h (12 MPH) condition.

NOTE:

The speed difference between front and rear wheels may light the ABS warning light, but this indicates no malfunction. When AT control diagnosis is finished, perform the ABS memory clearance procedure of on-board diagnostics system. <Ref. to 4-4 [T6D2].>

- 4) Measure voltage between TCM connector terminals.

Connector & terminal

(B55) No. 12 (+) — No. 21 (-):

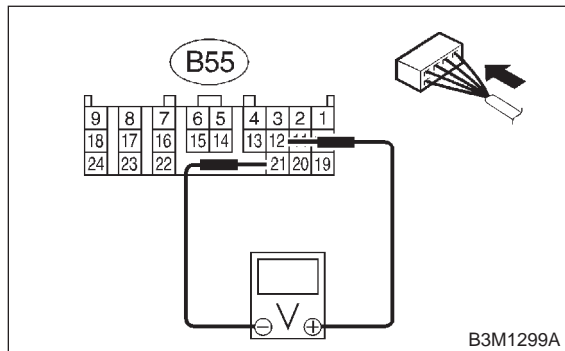

- CHECK** : **Is the voltage more than AC 1 V?**
- YES** : Even if "AT OIL TEMP" lights up, the circuit has returned to a normal condition at this time. A temporary poor contact of the connector or harness may be the cause. Repair harness or connector in the TCM and transmission.
- NO** : Go to step **8G11**.

8G9 : CHECK INPUT SIGNAL FOR TCM USING SUBARU SELECT MONITOR.

- 1) Connect connector to transmission.
- 2) Connect Subaru Select Monitor to data link connector.

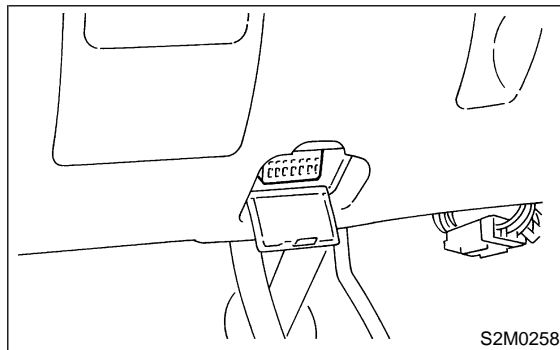

- 3) Lift-up or raise the vehicle and support with safety stand.

CAUTION:

On AWD models, raise all wheels off ground.

- 4) Turn ignition switch to ON and turn Subaru Select Monitor switch to ON.
- 5) Start the engine.
- 6) Read data of vehicle speed using Subaru Select Monitor.
 - Compare speedometer with Subaru Select Monitor indications.
 - Vehicle speed is indicated in "km/h" or "MPH".
- 7) Slowly increase vehicle speed to 20 km/h or 12 MPH.

NOTE:

The speed difference between front and rear wheels may light the ABS warning light, but this indicates no malfunction. When AT control diagnosis is finished, perform the ABS memory clearance procedure of on-board diagnostics system. <Ref. to 4-4 [T6D2].>

- CHECK** : **Is the revolution value same as the tachometer reading shown on the combination meter?**
- YES** : Even if "AT OIL TEMP" lights up, the circuit has returned to a normal condition at this time. A temporary poor contact of the connector or harness may be the cause. Repair harness or connector in the TCM and transmission.
- NO** : Go to step **8G11**.

8G10 : CHECK INPUT SIGNAL FOR TCM USING OSCILLOSCOPE.

- 1) Connect connector to transmission.
- 2) Lift-up or raise the vehicle and support with safety stand.

CAUTION:

On AWD models, raise all wheels off ground.

- 3) Set oscilloscope to TCM connector terminals. Position probe; (B55) No. 12 Earth lead; (B55) No. 21

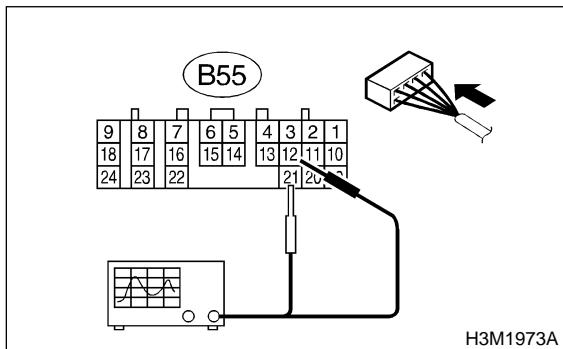

- 4) Start the engine and set vehicle in 20 km/h (12 MPH) condition.

NOTE:

The speed difference between front and rear wheels may light the ABS warning light, but this indicates no malfunction. When AT control diagnosis is finished, perform the ABS memory clearance procedure of on-board diagnostics system. <Ref. to 4-4 [T6D2].>

- 5) Measure signal voltage indicated on oscilloscope.

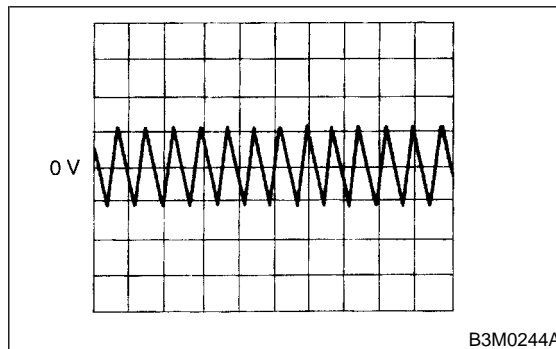

- CHECK** : *Is the signal voltage more than AC 1 V?*
- YES** : Even if "AT OIL TEMP" lights up, the circuit has returned to a normal condition at this time. A temporary poor contact of the connector or harness may be the cause. Repair harness or connector in the TCM and transmission.
- NO** : Go to step **8G11**.

8G11 : CHECK POOR CONTACT.

- CHECK** : *Is there poor contact in torque converter turbine speed sensor circuit?*
- YES** : Repair poor contact.
- NO** : Replace TCM. <Ref. to 3-2 [W23A0].>

H: TROUBLE CODE 38 — TORQUE CONTROL SIGNAL —

DIAGNOSIS:

- The signal circuit is open or shorted.

TROUBLE SYMPTOM:

Excessive shift shock.

WIRING DIAGRAM:

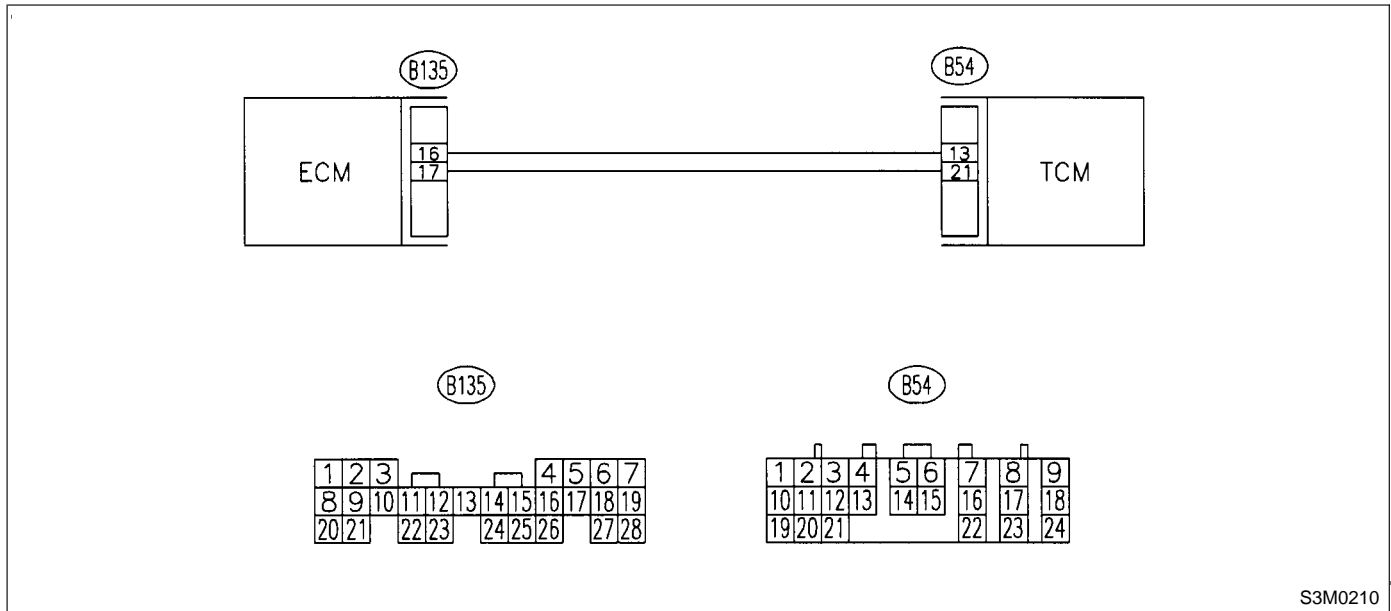

S3M0210

8H1 : CHECK HARNESS CONNECTOR BETWEEN TCM AND ECM.

- 1) Turn ignition switch to OFF.
- 2) Measure resistance of harness between TCM and ECM connector.

Connector & terminal

(B54) No. 21 — (B135) No. 17:

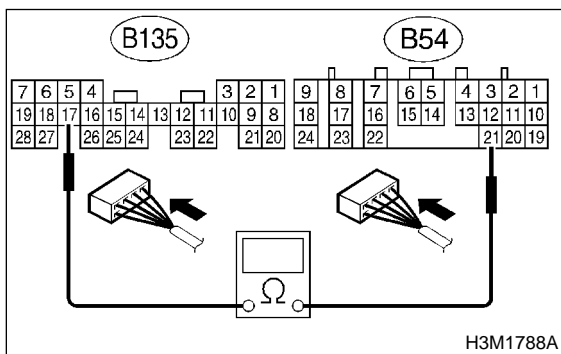

H3M1788A

- CHECK** : Is the resistance less than 1 Ω?
- YES** : Go to step **8H2**.
- NO** : Repair open circuit in harness between TCM and ECM connector.

8H2 : CHECK HARNESS CONNECTOR BETWEEN TCM AND ECM.

Measure resistance of harness between TCM and ECM connector.

Connector & terminal

(B54) No. 13 — (B135) No. 16:

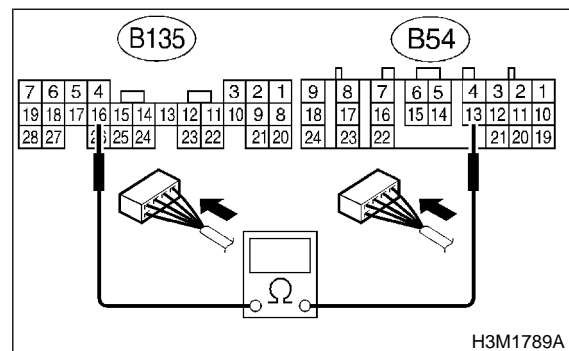

H3M1789A

- CHECK** : Is the resistance less than 1 Ω?
- YES** : Go to step **8H3**.
- NO** : Repair open circuit in harness between TCM and ECM connector.

8H3 : CHECK HARNESS CONNECTOR BETWEEN TCM AND ECM.

Measure resistance of harness between TCM connector and chassis ground.

Connector & terminal

(B54) No. 21 — Chassis ground:

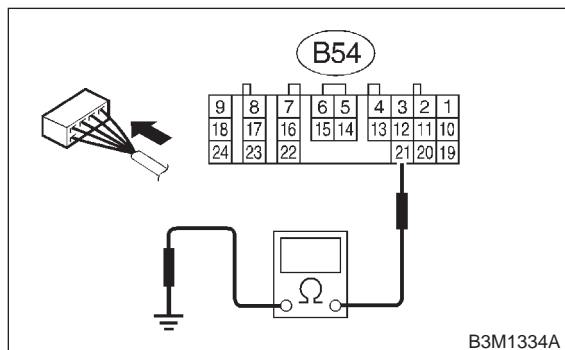

- CHECK** : *Is the resistance more than 1 MΩ?*
- YES** : Go to step 8H4.
- NO** : Repair short circuit in harness between TCM and ECM connector.

8H4 : CHECK HARNESS CONNECTOR BETWEEN TCM AND ECM.

Measure resistance of harness between TCM connector and chassis ground.

Connector & terminal

(B54) No. 13 — Chassis ground:

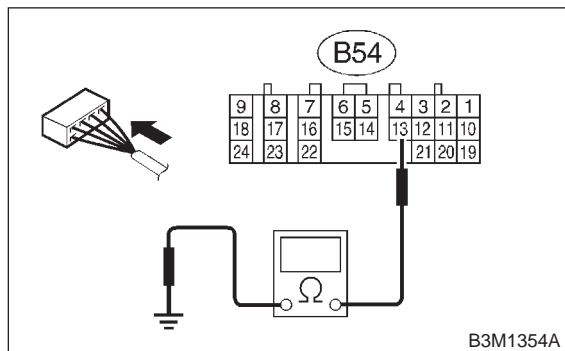

- CHECK** : *Is the resistance more than 1 MΩ?*
- YES** : Go to step 8H5.
- NO** : Repair short circuit in harness between TCM and ECM connector.

8H5 : CHECK OUTPUT SIGNAL EMITTED FROM TCM.

- 1) Turn ignition switch to ON and start engine.
- 2) Measure voltage between TCM connector terminals.

Connector & terminal

(B54) No. 13 (+) — (B55) No. 19:

(B54) No. 21 (+) — (B55) No. 19:

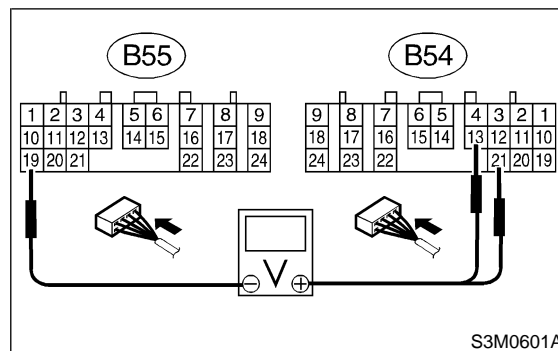

- CHECK** : *Is each voltage more than 4.8 V?*
- YES** : Even if “AT OIL TEMP” lights up, the circuit has returned to a normal condition at this time. A temporary poor contact of the connector or harness may be the cause. Repair harness or connector in the TCM and ECM.
- NO** : Go to step 8H6.

8H6 : CHECK POOR CONTACT.

- CHECK** : *Is there poor contact in torque control signal circuit?*
- YES** : Repair poor contact.
- NO** : Go to step 8H7.

8H7 : CHECK GROUND LINE BETWEEN TRANSMISSION AND BODY.

Check installing condition of ground line in transmission and body.

- CHECK** : *Is there any dirt or rust at ground line installing point?*
- YES** : Remove dirt and rust.
- NO** : Go to step 8H8.

8H8 : CHECK GROUND LINE BETWEEN TRANSMISSION AND BODY.

Check installing condition of ground line in transmission and body.

Tightening torque:

13±3 N·m (1.3±0.3 kg·m, 9.4±2.2 ft·lb)

CHECK : Is tightening torque value within specification?

YES : Go to step 8H9.

NO : Tighten to specified torque.

8H9 : CHECK GROUND LINE INSIDE TRANSMISSION.

- 1) Drain AT fluid and remove oil pan.
- 2) Check tightening torque value of ground line installing bolt.

Tightening torque:

T: 8±1 N·m (0.8±0.1 kg·m, 5.8±0.7 ft·lb)

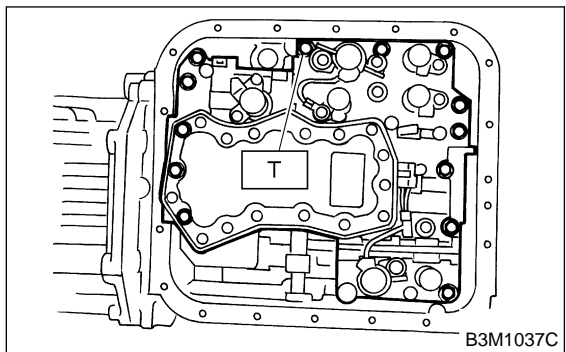

CHECK : Is tightening torque value within specification?

YES : Go to step 8H10.

NO : Tighten to specified torque.

8H10 : RECHECK OUTPUT SIGNAL EMITTED FROM TCM.

Measure voltage between TCM connector terminals.

Connector & terminal

(B54) No. 13 (+) — (B55) No. 19 (-):

(B54) No. 21 (+) — (B55) No. 19 (-):

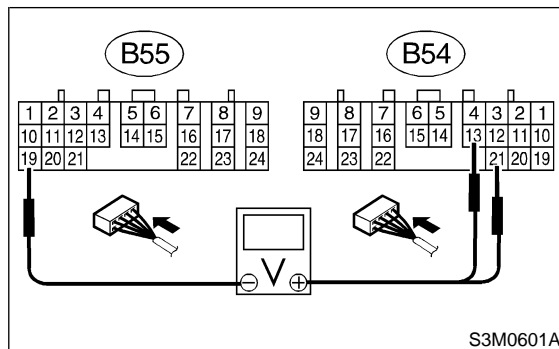

CHECK : Is each voltage more than 4.8 V?

YES : Replace TCM. <Ref. to 3-2 [W23A0].>

NO : Replace ECM. <Ref. to 2-7 [W17A0].>

MEMO:

I: TROUBLE CODE 45 — INTAKE MANIFOLD PRESSURE SIGNAL —

DIAGNOSIS:

Input signal circuit of TCM from ECM is open or shorted.

TROUBLE SYMPTOM:

Excessive shift shock.

WIRING DIAGRAM:

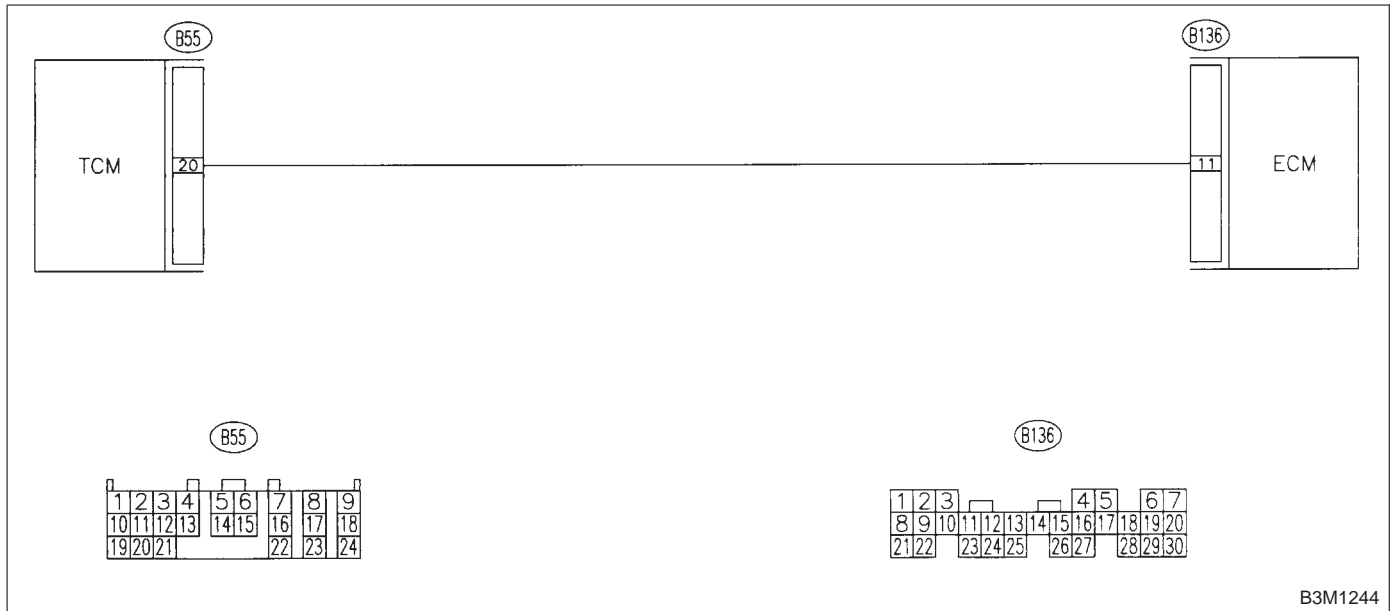

8I1 : CHECK HARNESS CONNECTOR BETWEEN TCM AND ECM.

- 1) Turn ignition switch to OFF.
- 2) Measure resistance of harness between TCM and ECM connector.

Connector & terminal

(B55) No. 20 — (B136) No. 11:

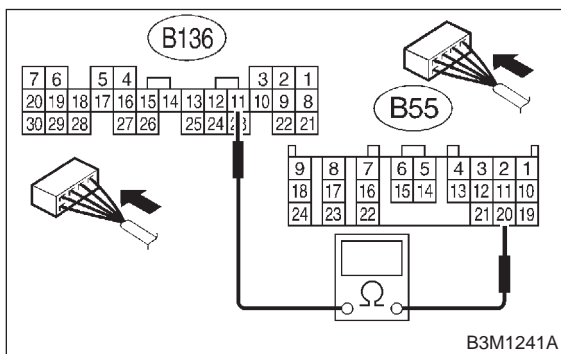

- CHECK** : Is the resistance less than 1 Ω?
- YES** : Go to step 8I2.
- NO** : Repair open circuit in harness between TCM and ECM connector.

8I2 : CHECK HARNESS CONNECTOR BETWEEN TCM AND ECM.

Measure resistance of harness between TCM connector and chassis ground.

Connector & terminal

(B55) No. 20 — Chassis ground:

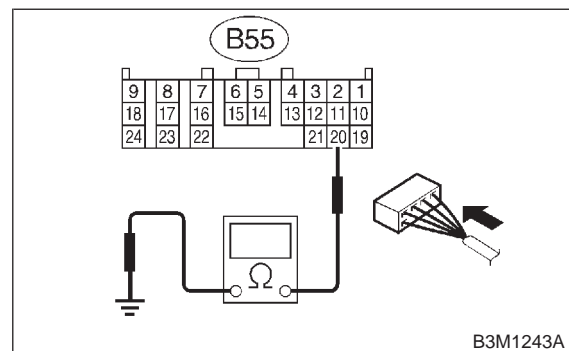

- CHECK** : Is the resistance more than 1 MΩ?
- YES** : Go to step 8I3.
- NO** : Repair short circuit in harness between TCM and ECM connector.

813 : PREPARE SUBARU SELECT MONITOR.

CHECK : *Do you have a Subaru Select Monitor?*

YES : Go to step **815**.

NO : Go to step **814**.

814 : CHECK INPUT SIGNAL FOR TCM.

1) Start the engine, and warm-up the transmission until ATF temperature is above 80°C (176°F).

NOTE:

If ambient temperature is below 0°C (32°F), drive the vehicle until the ATF reaches its operating temperature.

2) Engine idling.

3) Measure voltage between TCM connectors.

Connector & terminal

(B55) No. 20 (+) — No. 19 (-):

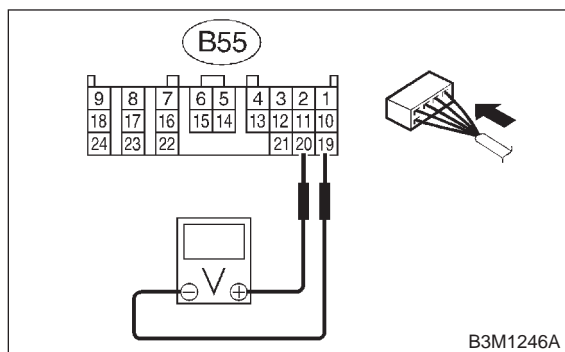

CHECK : *Is the voltage between 1.2 and 1.8 V?*

YES : Even if "AT OIL TEMP" lights up, the circuit has returned to a normal condition at this time. A temporary poor contact of the connector or harness may be the cause. Repair harness or connector in the TCM and ECM.

NO : Go to step **816**.

815 : CHECK INPUT SIGNAL FOR TCM USING SUBARU SELECT MONITOR.

1) Turn ignition switch to OFF.

2) Connect Subaru Select Monitor to data link connector.

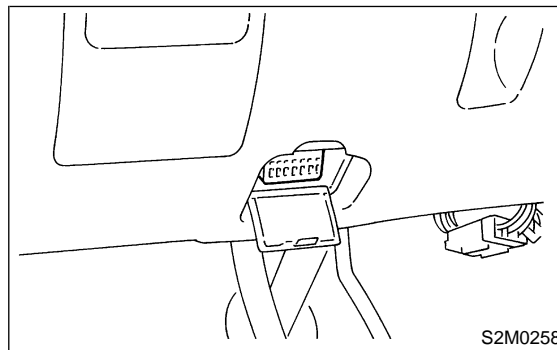

3) Start the engine, and turn Subaru Select monitor switch to ON.

4) Warm-up the engine until engine coolant temperature is above 80°C (176°F).

5) Engine idling.

6) Read data of intake manifold pressure signal using Subaru Select Monitor.

● Display shows intake manifold pressure signal value sent from ECM.

CHECK : *Is the value between 1.2 and 1.8 V?*

YES : Even if "AT OIL TEMP" lights up, the circuit has returned to a normal condition at this time. A temporary poor contact of the connector or harness may be the cause. Repair harness or connector in the TCM and ECM.

NO : Go to step **816**.

816 : CHECK POOR CONTACT.

CHECK : *Is there poor contact in intake manifold pressure signal circuit?*

YES : Repair poor contact.

NO : Replace TCM. <Ref. to 3-2 [W23A0].>

J: TROUBLE CODE 71 — SHIFT SOLENOID 1 —

DIAGNOSIS:

Output signal circuit of shift solenoid 1 is open or shorted.

TROUBLE SYMPTOM:

Does not shift.

WIRING DIAGRAM:

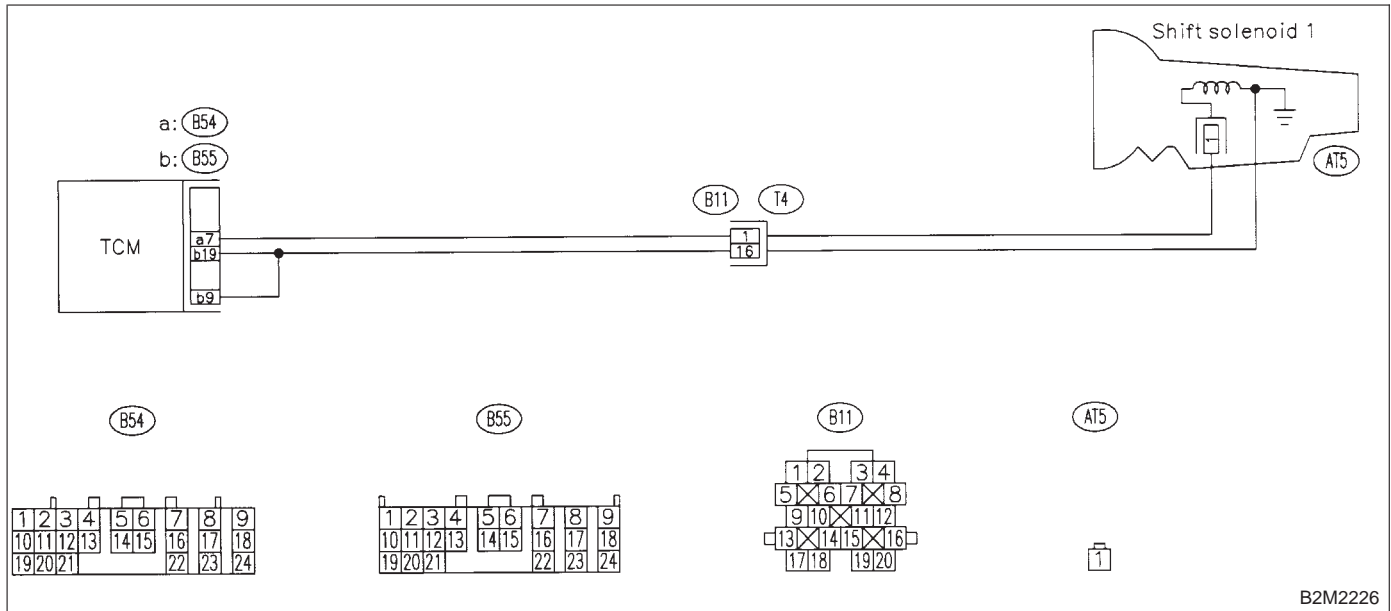

8J1 : CHECK SHIFT SOLENOID 1 GROUND LINE.

- 1) Turn ignition switch to OFF.
- 2) Disconnect connector from transmission.
- 3) Measure resistance between transmission connector and transmission ground.

Connector & terminal

(T4) No. 16 — Transmission ground:

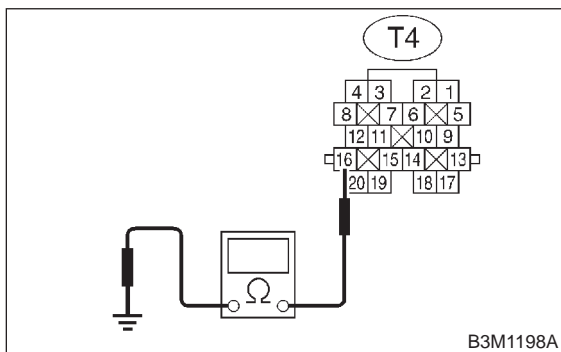

- CHECK** : Is the resistance less than 1 Ω?
- YES** : Go to step 8J2.
- NO** : Repair open circuit in transmission harness.

8J2 : CHECK SHIFT SOLENOID 1.

Measure resistance between transmission connector and transmission ground.

Connector & terminal

(T4) No. 1 — Transmission ground:

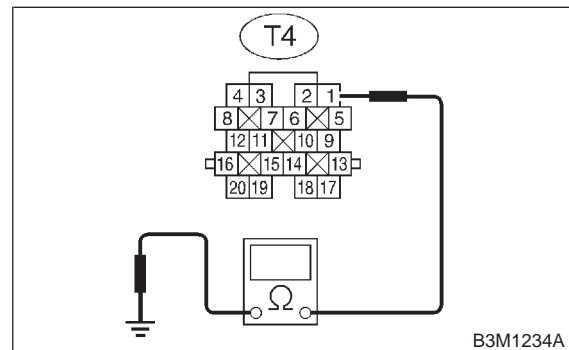

- CHECK** : Is the resistance between 10 and 16 Ω?
- YES** : Go to step 8J3.
- NO** : Go to step 8J6.

8J3 : CHECK HARNESS CONNECTOR BETWEEN TCM AND TRANSMISSION.

Measure resistance of harness between TCM and shift solenoid 1 connector.

Connector & terminal
(B54) No. 7 — (B11) No. 1:

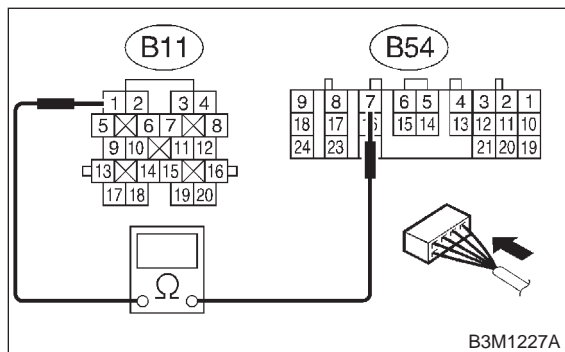

- CHECK** : *Is the resistance less than 1 Ω?*
- YES** : Go to step 8J4.
- NO** : Repair open circuit in harness between TCM and transmission connector.

8J4 : CHECK HARNESS CONNECTOR BETWEEN TCM AND TRANSMISSION.

Measure resistance of harness between TCM connector and chassis ground.

Connector & terminal
(B54) No. 7 — Chassis ground:

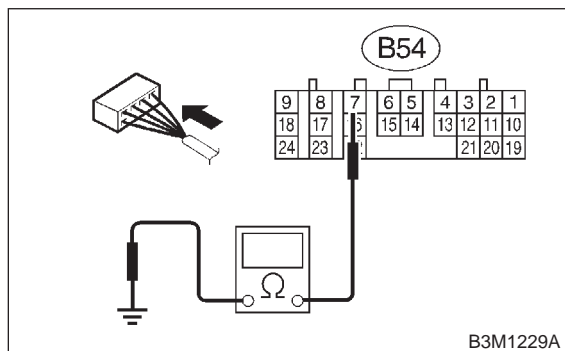

- CHECK** : *Is the resistance more than 1 MΩ?*
- YES** : Go to step 8J5.
- NO** : Repair short circuit in harness between TCM and transmission connector.

8J5 : CHECK OUTPUT SIGNAL EMITTED FROM TCM.

- 1) Connect connector to transmission.
- 2) Lift-up or raise the vehicle and support with safety stand.

CAUTION:
On AWD models, raise all wheels off ground.

- 3) Start the engine and warm-up the transmission until ATF temperature is above 80°C (176°F).

NOTE:
If ambient temperature is below 0°C (32°F), drive the vehicle until the ATF reaches its operating temperature.

- 4) Move select lever to “D”, and slowly increase vehicle speed to 50 km/h (31 MPH).

NOTE:
The speed difference between front and rear wheels may light the ABS warning light, but this indicates no malfunction. When AT control diagnosis is finished, perform the ABS memory clearance procedure of on-board diagnostics system. <Ref. to 4-4 [T6D2].>

- 5) Measure voltage between TCM connector and chassis ground.

Connector & terminal
(B54) No. 7 (+) — Chassis ground (-):

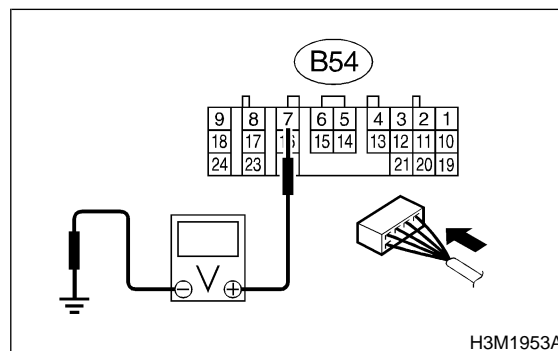

- CHECK** : *Is the voltage 1 V → 9 V?*
- YES** : Even if “AT OIL TEMP” lights up, the circuit has returned to a normal condition at this time. A temporary poor contact of the connector or harness may be the cause. Repair harness or connector in the TCM.
- NO** : Go to step 8J8.

8J6 : CHECK SHIFT SOLENOID 1 (IN TRANSMISSION).

- 1) Remove transmission connector from stay.
- 2) Lift-up or raise the vehicle and support with safety stand.

CAUTION:
On AWD models, raise all wheels off ground.

- 3) Drain automatic transmission fluid.

CAUTION:
Do not drain the automatic transmission fluid until it cools down.

- 4) Remove oil pan, and disconnect connector from shift solenoid 1.
- 5) Measure resistance between shift solenoid 1 connector and transmission ground.

Connector & terminal
No. 1 — Transmission ground:

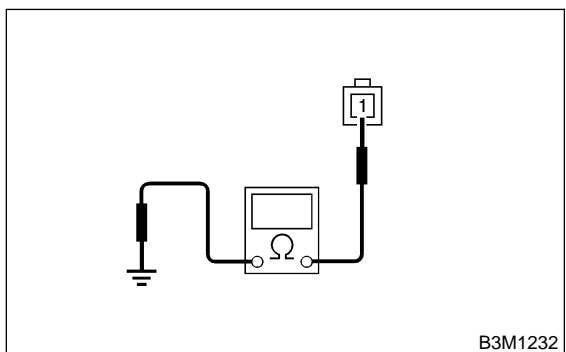

- CHECK** : Is the resistance between 10 and 16 Ω?
- YES** : Go to step 8J7.
- NO** : Replace shift solenoid 1. <Ref. to 3-2 [W4A0].>

8J7 : CHECK HARNESS CONNECTOR BETWEEN SHIFT SOLENOID 1 AND TRANSMISSION.

Measure resistance of harness between shift solenoid 1 and transmission connector.

Connector & terminal
(AT5) No. 1 — (T4) No. 1:

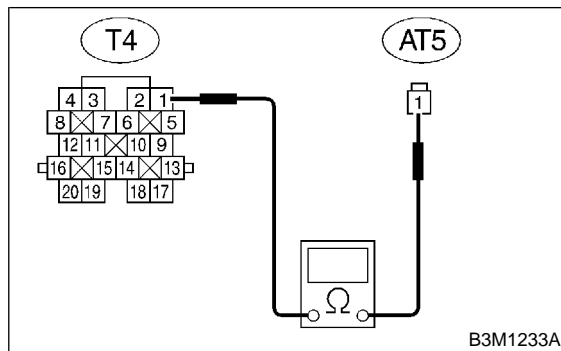

- CHECK** : Is the resistance less than 1 Ω?
- YES** : Go to step 8J8.
- NO** : Repair open circuit in harness between shift solenoid 1 and transmission connector.

8J8 : CHECK POOR CONTACT.

- CHECK** : Is there poor contact in shift solenoid 1 circuit?
- YES** : Repair poor contact.
- NO** : Replace TCM. <Ref. to 3-2 [W23A0].>

MEMO:

K: TROUBLE CODE 72 — SHIFT SOLENOID 2 —

DIAGNOSIS:

Output signal circuit of shift solenoid 2 is open or shorted.

TROUBLE SYMPTOM:

Does not shift.

WIRING DIAGRAM:

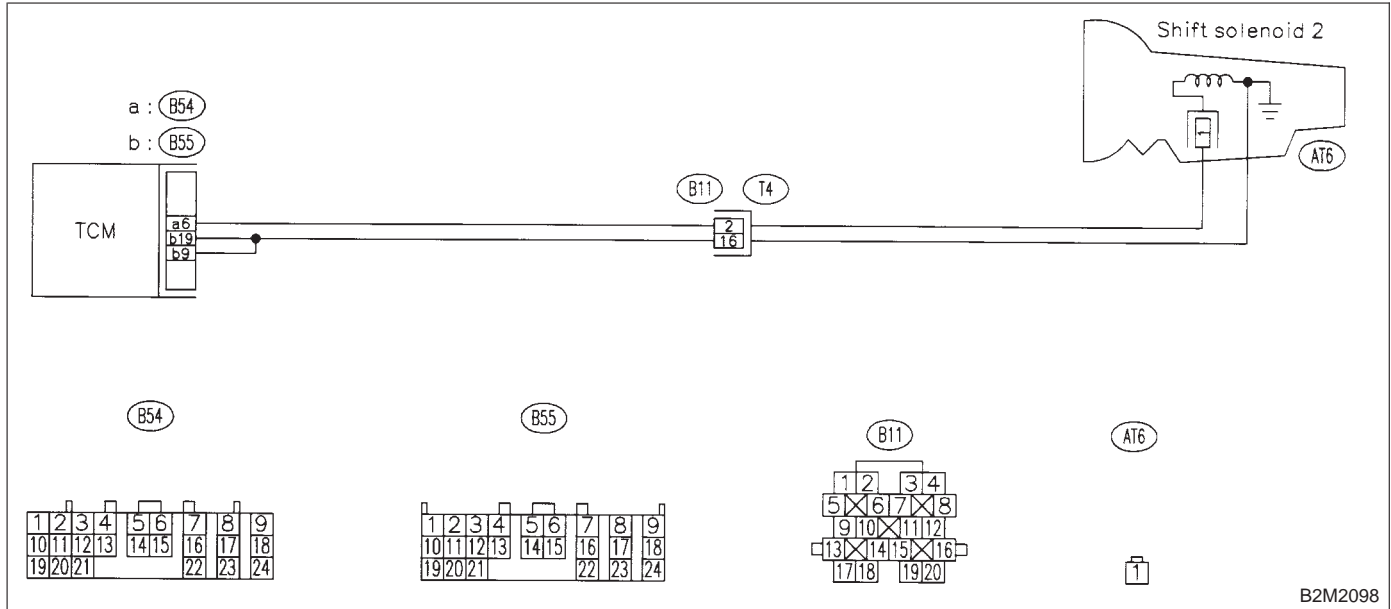

B2M2098

8K1 : CHECK SHIFT SOLENOID 2 GROUND LINE.

- 1) Turn ignition switch to OFF.
- 2) Disconnect connector from transmission.
- 3) Measure resistance between transmission connector and transmission ground.

Connector & terminal

(T4) No. 16 — Transmission ground:

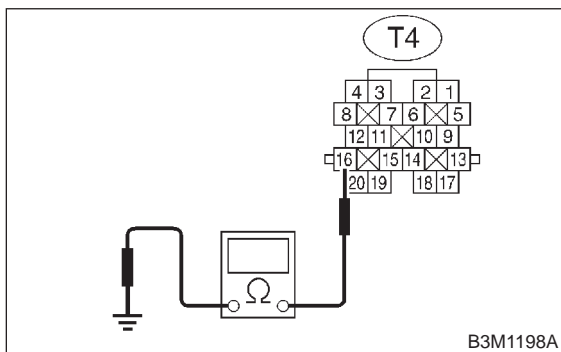

B3M1198A

- CHECK** : Is the resistance less than 1 Ω?
- YES** : Go to step 8K2.
- NO** : Repair open circuit in transmission harness.

8K2 : CHECK SHIFT SOLENOID 2.

Measure resistance between transmission connector and transmission ground.

Connector & terminal

(T4) No. 2 — Transmission ground:

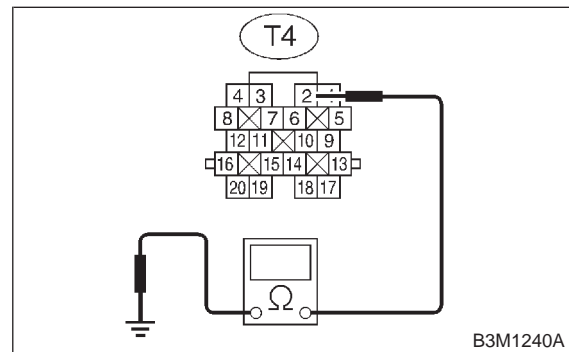

B3M1240A

- CHECK** : Is the resistance between 10 and 16 Ω?
- YES** : Go to step 8K3.
- NO** : Go to step 8K6.

8K3 : CHECK HARNESS CONNECTOR BETWEEN TCM AND TRANSMISSION.

Measure resistance of harness between TCM and transmission connector.

Connector & terminal

(B54) No. 6 — (B11) No. 2:

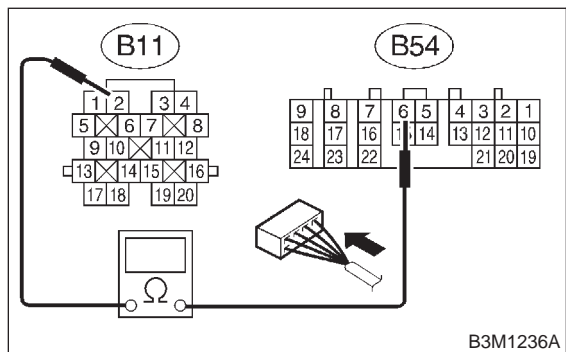

- CHECK** : *Is the resistance less than 1 Ω?*
- YES** : Go to step **8K4**.
- NO** : Repair open circuit in harness between TCM and transmission connector.

8K4 : CHECK HARNESS CONNECTOR BETWEEN TCM AND TRANSMISSION.

Measure resistance of harness between TCM connector and chassis ground.

Connector & terminal

(B54) No. 6 — Chassis ground:

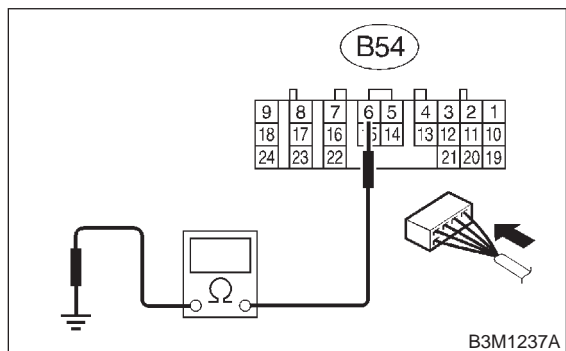

- CHECK** : *Is the resistance more than 1 MΩ?*
- YES** : Go to step **8K5**.
- NO** : Repair short circuit in harness between TCM and transmission connector.

8K5 : CHECK OUTPUT SIGNAL EMITTED FROM TCM.

- 1) Connect connector to transmission.
- 2) Lift-up or raise the vehicle and support with safety stand.

CAUTION:

On AWD models, raise all wheels off ground.

- 3) Start the engine, and warm-up the transmission until ATF temperature is above 80°C (176°F).

NOTE:

If ambient temperature is below 0°C (32°F), drive the vehicle until the ATF reaches its operating temperature.

- 4) Move select lever to “D”, and slowly increase vehicle speed to 50 km/h (31 MPH).

NOTE:

The speed difference between front and rear wheels may light the ABS warning light, but this indicates no malfunction. When AT control diagnosis is finished, perform the ABS memory clearance procedure of on-board diagnostics system. <Ref. to 4-4 [T6D2].>

- 5) Measure voltage between TCM connector and chassis ground.

Connector & terminal

(B54) No. 6 (+) — Chassis ground (-):

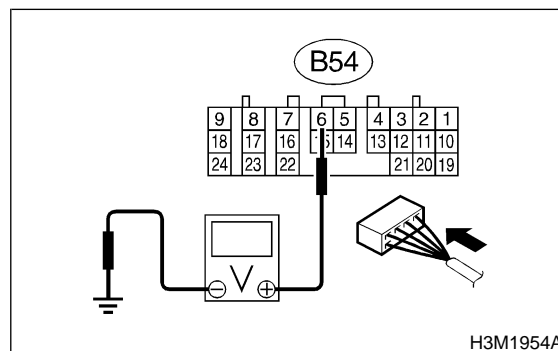

- CHECK** : *Is the voltage 9 V → 1 V?*
- YES** : Even if “AT OIL TEMP” lights up, the circuit has returned to a normal condition at this time. A temporary poor contact of the connector or harness may be the cause. Repair harness or contact in the TCM.
- NO** : Go to step **8K8**.

8K6 : CHECK SHIFT SOLENOID 2 (IN TRANSMISSION).

- 1) Remove transmission connector from stay.
- 2) Lift-up or raise the vehicle and support with safety stand.

CAUTION:
On AWD models, raise all wheels off ground.

- 3) Drain automatic transmission fluid.

CAUTION:
Do not drain the automatic transmission fluid until it cools down.

- 4) Remove oil pan, and disconnect connector from shift solenoid 2.
- 5) Measure resistance between shift solenoid 2 connector and transmission ground.

Connector & terminal
No. 1 — Transmission ground:

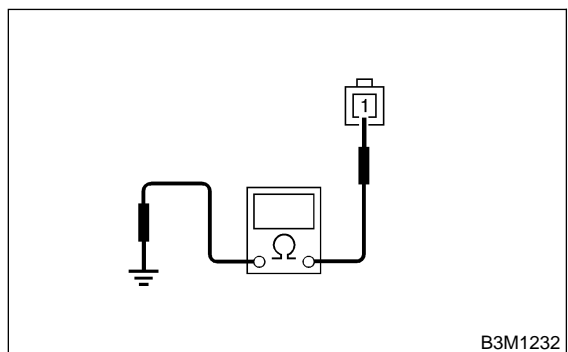

- CHECK** : Is the resistance between 10 and 16 Ω ?
- YES** : Go to step 8K7.
- NO** : Replace shift solenoid assembly. <Ref. to 3-2 [W4A0].>

8K7 : CHECK HARNESS CONNECTOR BETWEEN SHIFT SOLENOID 2 AND TRANSMISSION.

Measure resistance of harness between shift solenoid 2 and transmission connector.

Connector & terminal
(AT6) No. 1 — (T4) No. 2:

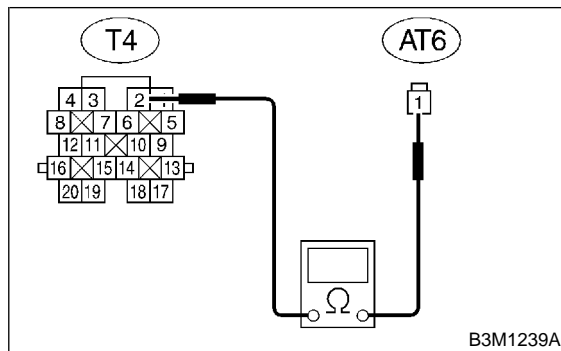

- CHECK** : Is the resistance less than 1 Ω ?
- YES** : Go to step 8K8.
- NO** : Repair open circuit in harness between shift solenoid 2 and transmission connector.

8K8 : CHECK POOR CONTACT.

- CHECK** : Is there poor contact in shift solenoid 2 circuit?
- YES** : Repair poor contact.
- NO** : Replace TCM. <Ref. to 3-2 [W23A0].>

MEMO:

L: TROUBLE CODE 73 — LOW CLUTCH TIMING SOLENOID —

DIAGNOSIS:

Output signal circuit of low clutch timing solenoid is open or shorted.

TROUBLE SYMPTOM:

Excessive shift shock.

WIRING DIAGRAM:

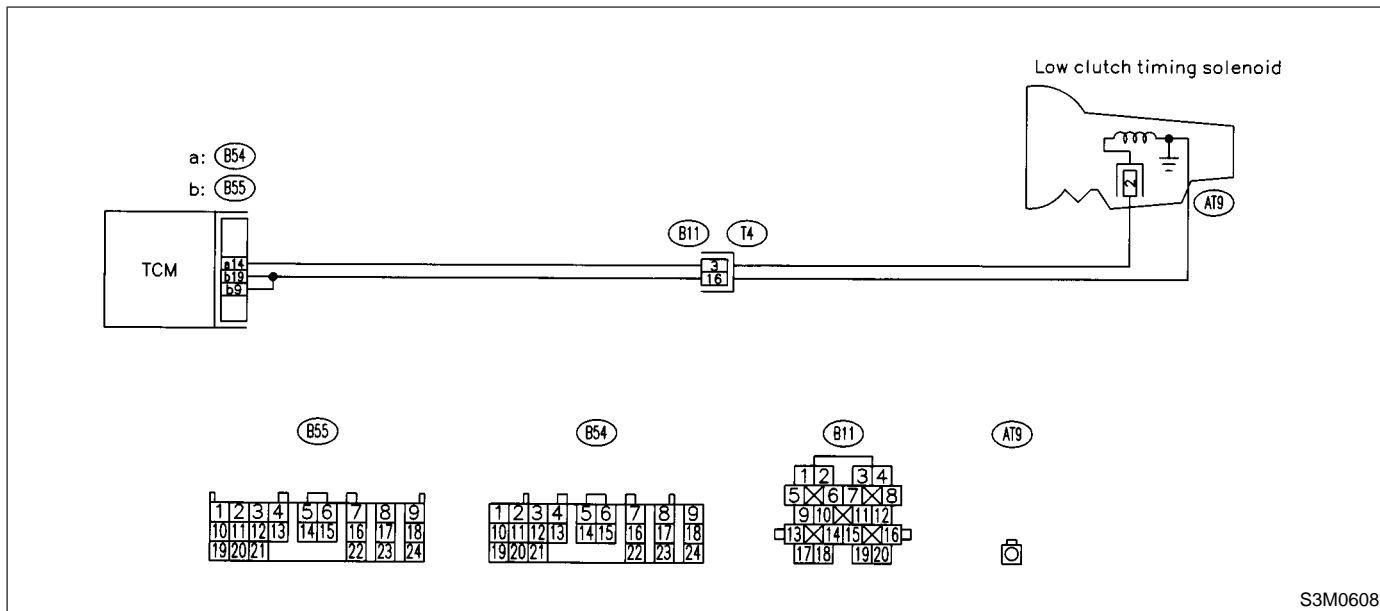

S3M0608

8L1 : CHECK LOW CLUTCH TIMING SOLENOID GROUND LINE.

- 1) Turn ignition switch to OFF.
- 2) Disconnect connector from transmission.
- 3) Measure resistance between transmission connector and transmission ground.

Connector & terminal

(T4) No. 16 — Transmission ground:

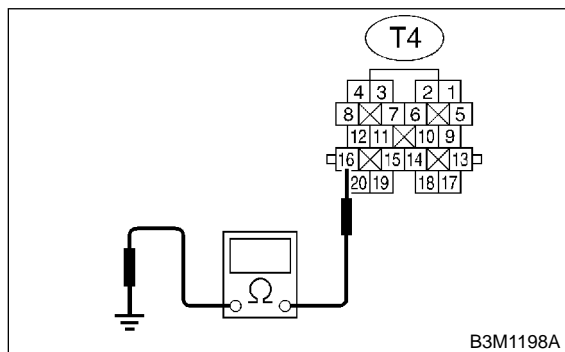

B3M1198A

- CHECK** : Is the resistance less than 1 Ω?
- YES** : Go to step 8L2.
- NO** : Repair open circuit in transmission harness.

8L2 : CHECK LOW CLUTCH TIMING SOLENOID.

Measure resistance between transmission connector and transmission ground.

Connector & terminal

(T4) No. 3 — Transmission ground:

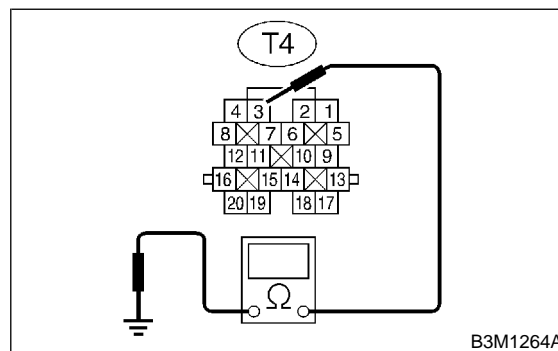

B3M1264A

- CHECK** : Is the resistance between 10 and 16 Ω?
- YES** : Go to step 8L3.
- NO** : Go to step 8L7.

8L3 : CHECK HARNESS CONNECTOR BETWEEN TCM AND TRANSMISSION.

Measure resistance of harness between TCM and transmission connector.

Connector & terminal

(B54) No. 14 — (B11) No. 3:

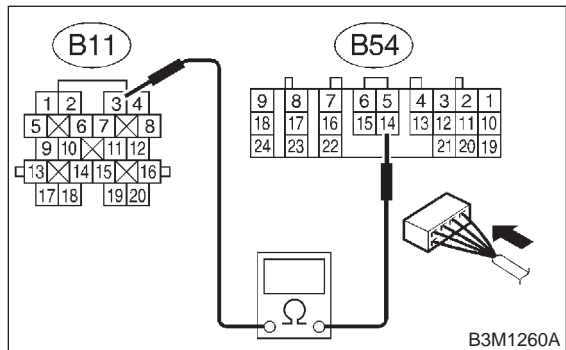

- CHECK** : *Is the resistance less than 1 Ω?*
- YES** : Go to step **8L4**.
- NO** : Repair open circuit in harness between TCM and transmission connector.

8L4 : CHECK HARNESS CONNECTOR BETWEEN TCM AND TRANSMISSION.

Measure resistance of harness between TCM connector and chassis ground.

Connector & terminal

(B54) No. 14 — Chassis ground:

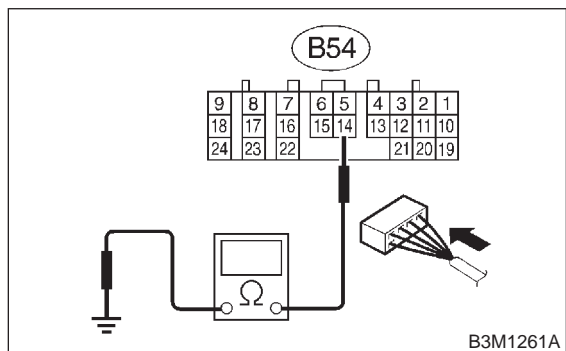

- CHECK** : *Is the resistance more than 1 MΩ?*
- YES** : Go to step **8L5**.
- NO** : Repair short circuit in harness between TCM and transmission connector.

8L5 : CHECK OUTPUT SIGNAL EMITTED FROM TCM.

- 1) Connect connector to transmission.
- 2) Lift-up or raise the vehicle and support with safety stand.

CAUTION:

On AWD models, raise all wheels off ground.

- 3) Start the engine and warm-up the transmission until ATF temperature is above 80°C (176°F).

NOTE:

If ambient temperature is below 0°C (32°F), drive the vehicle until the ATF reaches its operating temperature.

- 4) Move select lever to “2”, and slowly increase vehicle speed to 35 km/h (22 MPH).

NOTE:

The speed difference between front and rear wheels may light the ABS warning light, but this indicates no malfunction. When AT control diagnosis is finished, perform the ABS memory clearance procedure of on-board diagnostics system. <Ref. to 4-4 [T6D2].>

- 5) Measure voltage between TCM connector and chassis ground.

Connector & terminal

(B54) No. 14 (+) — Chassis ground (-):

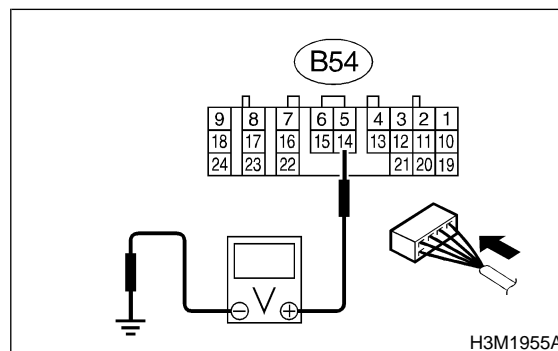

- CHECK** : *Is the voltage less than 1 V?*
- YES** : Go to step **8L6**.
- NO** : Go to step **8L9**.

8L6 : CHECK OUTPUT SIGNAL EMITTED FROM TCM.

1) Move select lever to "D", and slowly increase vehicle speed to 65 km/h (40 MPH).

NOTE:

The speed difference between front and rear wheels may light the ABS warning light, but this indicates no malfunction. When AT control diagnosis is finished, perform the ABS memory clearance procedure of on-board diagnostics system. <Ref. to 4-4 [T6D2].>

2) Measure voltage between TCM connector and chassis ground.

Connector & terminal

(B54) No. 14 (+) — Chassis ground (-):

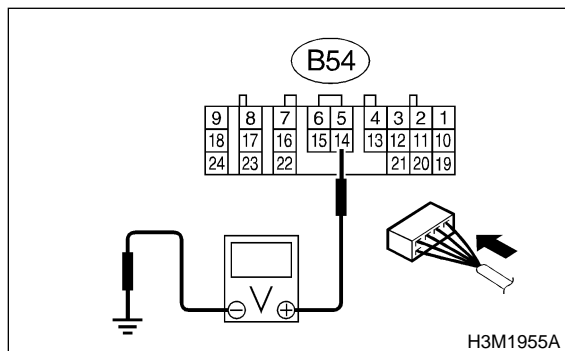

CHECK : **Is the voltage more than 9 V?**

YES : Even if "AT OIL TEMP" lights up, the circuit has returned to a normal condition at this time. A temporary poor contact of the connector or harness may be the cause. Repair harness or contact in the TCM.

NO : Go to step **8L9**.

8L7 : CHECK LOW CLUTCH TIMING SOLENOID (IN TRANSMISSION).

1) Remove transmission connector from stay.
2) Lift-up or raise the vehicle and support with safety stand.

CAUTION:

On AWD models, raise all wheels off ground.

3) Drain automatic transmission fluid.

CAUTION:

Do not drain the automatic transmission fluid until it cools down.

4) Remove oil pan, and disconnect connector from low clutch timing solenoid.

5) Measure resistance between low clutch timing solenoid connector and transmission ground.

Connector & terminal

No. 1 — Transmission ground:

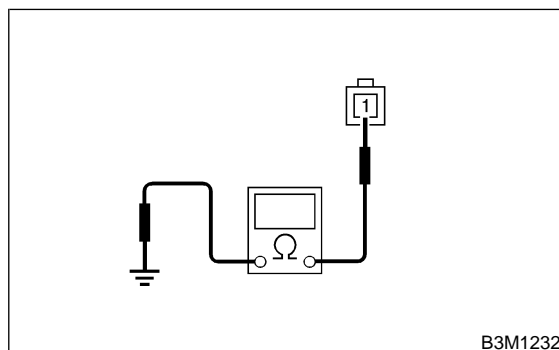

CHECK : **Is the resistance between 10 and 16 Ω?**

YES : Go to step **8L8**.

NO : Replace low clutch timing solenoid. <Ref. to 3-2 [W4A0].>

8L8 : CHECK HARNESS CONNECTOR BETWEEN LOW CLUTCH TIMING SOLENOID AND TRANSMISSION.

Measure resistance of harness between low clutch timing solenoid and transmission connector.

Connector & terminal

(AT9) No. 1 — (T4) No. 3:

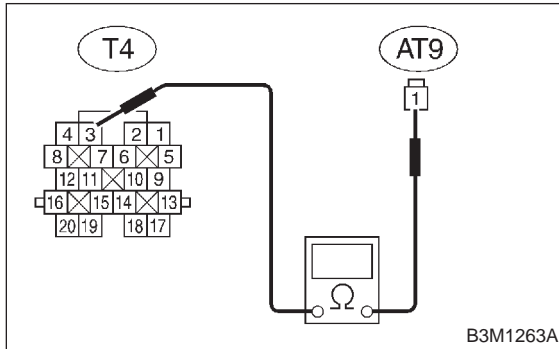

- CHECK** : *Is the resistance less than 1 Ω?*
- YES** : Go to step **8L9**.
- NO** : Repair open circuit in harness between low clutch timing solenoid and transmission connector.

8L9 : CHECK POOR CONTACT.

- CHECK** : *Is there poor contact in low clutch timing solenoid circuit?*
- YES** : Repair poor contact.
- NO** : Replace TCM. <Ref. to 3-2 [W23A0].>

M: TROUBLE CODE 74 — 2-4 BRAKE TIMING SOLENOID —

DIAGNOSIS:

Output signal circuit of 2-4 brake timing solenoid is open or shorted.

TROUBLE SYMPTOM:

Excessive shift shock.

WIRING DIAGRAM:

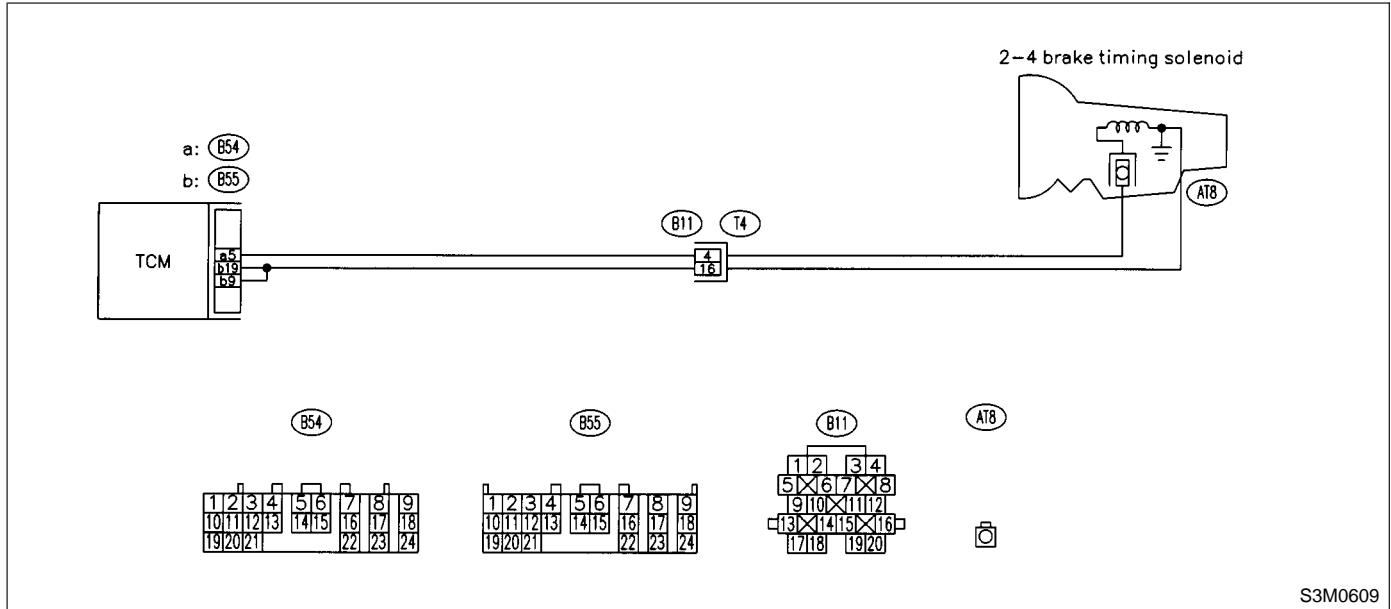

8M1 : CHECK 2-4 BRAKE TIMING SOLENOID GROUND LINE.

- 1) Turn ignition switch to OFF.
- 2) Disconnect connector from transmission.
- 3) Measure resistance between transmission connector and transmission ground.

Connector & terminal

(T4) No. 16 — Transmission ground:

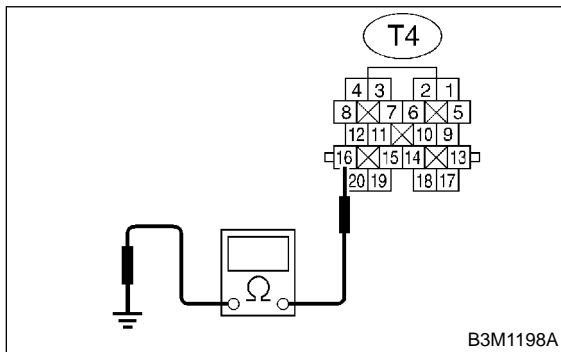

- CHECK** : Is the resistance less than 1 Ω?
- YES** : Go to step 8M2.
- NO** : Repair open circuit in transmission harness.

8M2 : CHECK 2-4 BRAKE TIMING SOLENOID.

Measure resistance between transmission connector and transmission ground.

Connector & terminal

(T4) No. 4 — Transmission ground:

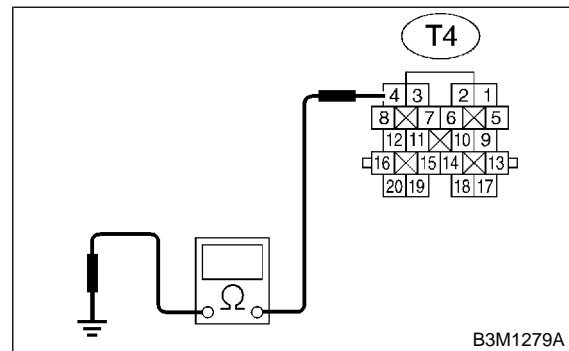

- CHECK** : Is the resistance between 10 and 16 Ω?
- YES** : Go to step 8M3.
- NO** : Go to step 8M7.

8M3 : CHECK HARNESS CONNECTOR BETWEEN TCM AND TRANSMISSION.

Measure resistance of harness between TCM and transmission connector.

Connector & terminal

(B54) No. 5 — (B11) No. 4:

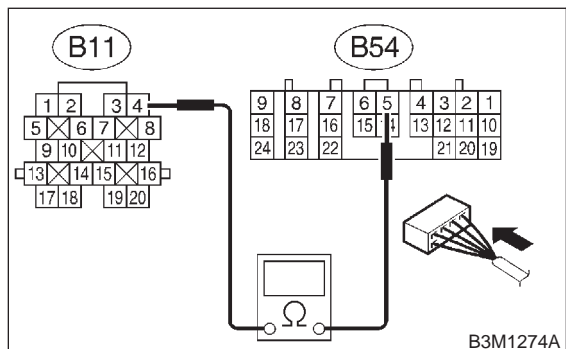

- CHECK** : *Is the resistance less than 1 Ω?*
- YES** : Go to step **8M4**.
- NO** : Repair open circuit in harness between TCM and transmission connector.

8M4 : CHECK HARNESS CONNECTOR BETWEEN TCM AND TRANSMISSION.

Measure resistance of harness between TCM connector and chassis ground.

Connector & terminal

(B54) No. 5 — Chassis ground:

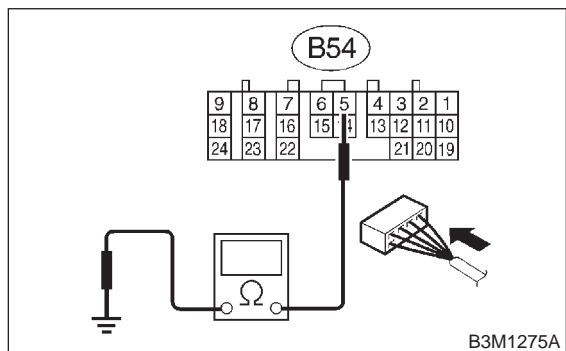

- CHECK** : *Is the resistance more than 1 MΩ?*
- YES** : Go to step **8M5**.
- NO** : Repair short circuit in harness between TCM and transmission connector.

8M5 : CHECK OUTPUT SIGNAL EMITTED FROM TCM.

- 1) Connect connector to transmission.
- 2) Lift-up or raise the vehicle and support with safety stand.

CAUTION:

On AWD models, raise all wheels off ground.

- 3) Start the engine and warm-up the transmission until ATF temperature is above 80°C (176°F).

NOTE:

If ambient temperature is below 0°C (32°F), drive the vehicle until the ATF reaches its operating temperature.

- 4) Move select lever to “1”, and slowly increase vehicle speed to 10 km/h (6 MPH).

NOTE:

The speed difference between front and rear wheels may light the ABS warning light, but this indicates no malfunction. When AT control diagnosis is finished, perform the ABS memory clearance procedure of on-board diagnostics system. <Ref. to 4-4 [T6D2].>

- 5) Measure voltage between TCM connector and chassis ground.

Connector & terminal

(B54) No. 5 (+) — Chassis ground (-):

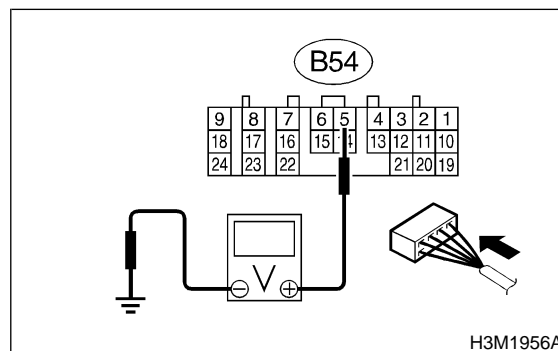

- CHECK** : *Is the voltage less than 1 V?*
- YES** : Go to step **8M6**.
- NO** : Go to step **8M9**.

8M6 : CHECK OUTPUT SIGNAL EMITTED FROM TCM.

1) Move select lever to "3", and slowly increase vehicle speed to 10 km/h (6 MPH).

NOTE:

The speed difference between front and rear wheels may light the ABS warning light, but this indicates no malfunction. When AT control diagnosis is finished, perform the ABS memory clearance procedure of on-board diagnostics system. <Ref. to 4-4 [T6D2].>

2) Measure voltage between TCM connector and chassis ground.

Connector & terminal

(B54) No. 5 (+) — Chassis ground (-):

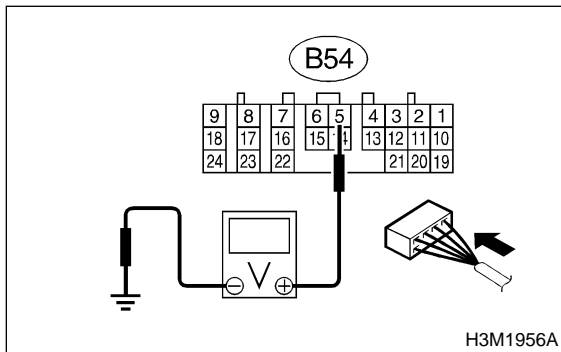

- CHECK** : **Is the voltage more than 9 V?**
- YES** : Even if "AT OIL TEMP" lights up, the circuit has returned to a normal condition at this time. A temporary poor contact of the connector or harness may be the cause. Repair harness or contact in the TCM.
- NO** : Go to step **8M9**.

8M7 : CHECK 2-4 BRAKE TIMING SOLENOID (IN TRANSMISSION).

1) Remove transmission connector from stay.
 2) Lift-up or raise the vehicle and support with safety stand.

CAUTION:

On AWD models, raise all wheels off ground.

3) Drain automatic transmission fluid.

CAUTION:

Do not drain the automatic transmission fluid until it cools down.

4) Remove oil pan, and disconnect connector from 2-4 brake timing solenoid.

5) Measure resistance between 2-4 brake timing solenoid connector and transmission ground.

Connector & terminal

No. 1 — Transmission ground:

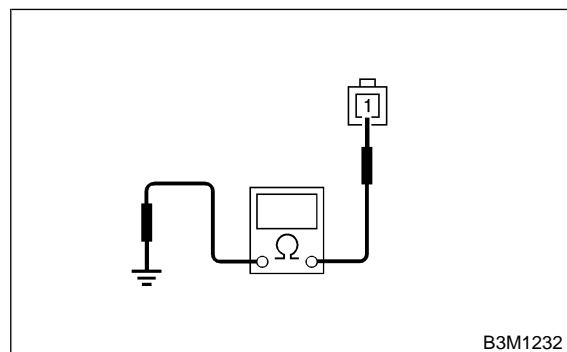

- CHECK** : **Is the resistance between 10 and 16 Ω?**
- YES** : Go to step **8M8**.
- NO** : Replace 2-4 brake timing solenoid. <Ref. to 3-2 [W4A0].>

8M8 : CHECK HARNESS CONNECTOR BETWEEN 2-4 BRAKE TIMING SOLENOID AND TRANSMISSION.

Measure resistance of harness between 2-4 brake timing solenoid and transmission connector.

Connector & terminal

(AT8) No. 1 — (T4) No. 4:

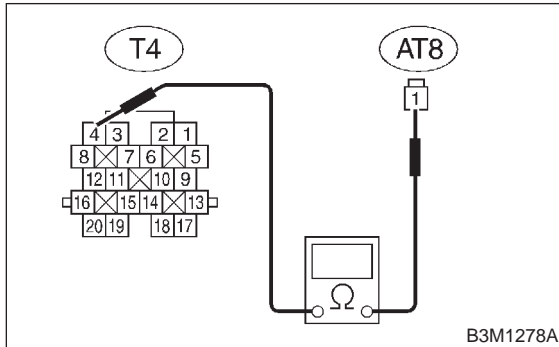

- CHECK** : *Is the resistance less than 1 Ω?*
- YES** : Go to step **8M9**.
- NO** : Repair open circuit in harness between 2-4 brake timing solenoid and transmission connector.

8M9 : CHECK POOR CONTACT.

- CHECK** : *Is there poor contact in 2-4 brake timing solenoid circuit?*
- YES** : Repair poor contact.
- NO** : Replace TCM. <Ref. to 3-2 [W23A0].>

N: TROUBLE CODE 75 — LINE PRESSURE DUTY SOLENOID —

DIAGNOSIS:

Output signal circuit of line pressure duty solenoid or resistor is open or shorted.

TROUBLE SYMPTOM:

Excessive shift shock.

WIRING DIAGRAM:

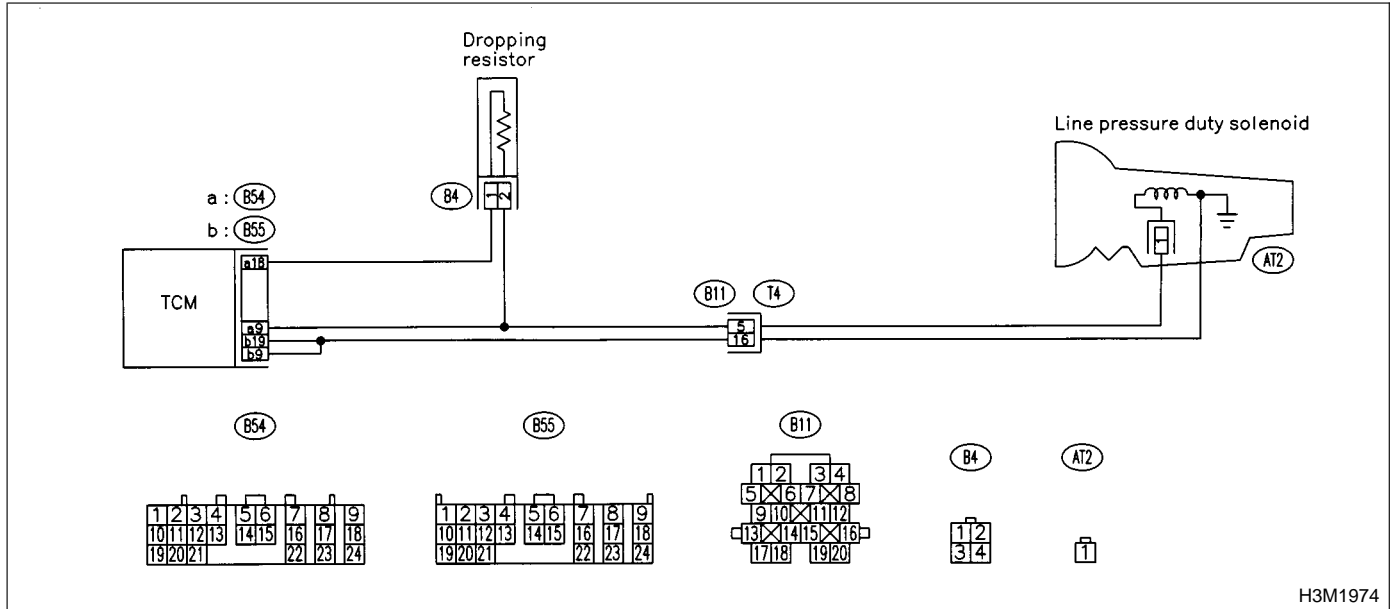

8N1 : CHECK RESISTOR.

- 1) Turn ignition switch to OFF.
- 2) Disconnect connector from dropping resistor.
- 3) Measure resistance between dropping resistor terminal.

Terminals

No. 1 — No. 2:

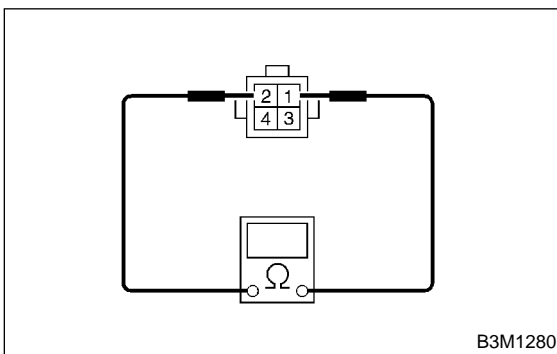

- CHECK** : Is the resistance between 9 and 15 Ω ?
- YES** : Go to step **8N2**.
- NO** : Replace dropping resistor. <Ref. to 3-2 [W24A0].>

8N2 : CHECK HARNESS CONNECTOR BETWEEN TCM AND DROPPING RESISTOR.

Measure resistance of harness between TCM connector and dropping resistor connector.

Connector & terminal

(B54) No. 18 — (B4) No. 1:

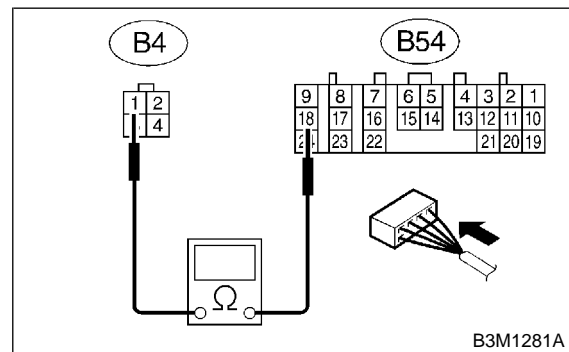

- CHECK** : Is the resistance less than 1 Ω ?
- YES** : Go to step **8N3**.
- NO** : Repair open circuit in harness between TCM and dropping resistor connector.

8N3 : CHECK HARNESS CONNECTOR BETWEEN TCM AND DROPPING RESISTOR.

Measure resistance of harness between dropping resistor connector and chassis ground.

Connector & terminal

(B4) No. 1 — Chassis ground:

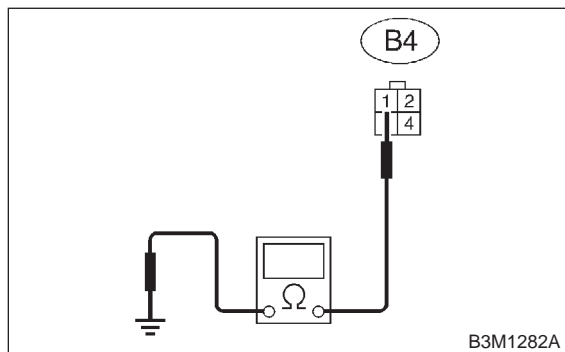

- CHECK** : **Is the resistance more than 1 MΩ?**
- YES** : Go to step **8N4**.
- NO** : Repair short circuit in harness between TCM and dropping resistor connector.

8N4 : CHECK HARNESS CONNECTOR BETWEEN TRANSMISSION AND DROPPING RESISTOR.

- 1) Disconnect connector from transmission.
- 2) Measure resistance of harness between transmission and dropping resistor connector.

Connector & terminal

(B4) No. 2 — (B11) No. 5:

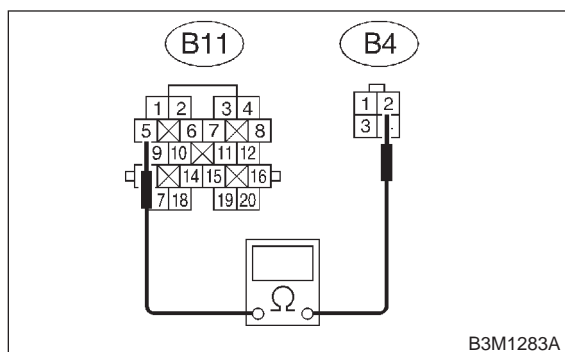

- CHECK** : **Is the resistance less than 1 Ω?**
- YES** : Go to step **8N5**.
- NO** : Repair open circuit in harness between dropping resistor and transmission connector.

8N5 : CHECK HARNESS CONNECTOR BETWEEN TRANSMISSION AND DROPPING RESISTOR.

Measure resistance of harness between dropping resistor connector and chassis ground.

Connector & terminal

(B4) No. 2 — Chassis ground:

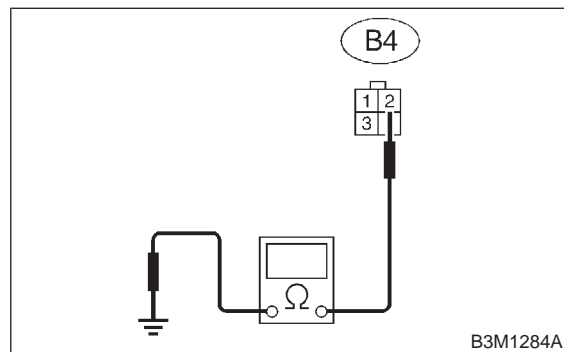

- CHECK** : **Is the resistance more than 1 MΩ?**
- YES** : Go to step **8N6**.
- NO** : Repair short circuit in harness between dropping resistor and transmission connector.

8N6 : CHECK LINE PRESSURE DUTY SOLENOID GROUND LINE.

Measure resistance between transmission connector and transmission ground.

Connector & terminal

(T4) No. 16 — Transmission ground:

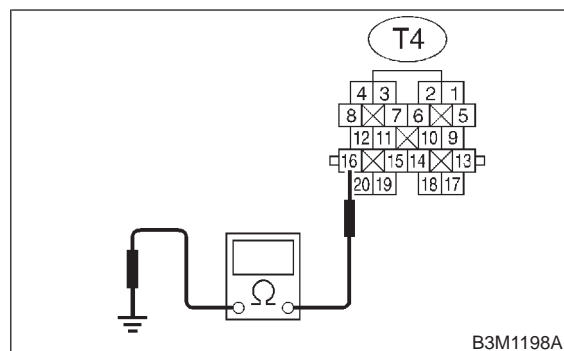

- CHECK** : **Is the resistance less than 1 Ω?**
- YES** : Go to step **8N7**.
- NO** : Repair open circuit in transmission harness.

8N7 : CHECK LINE PRESSURE DUTY SOLENOID.

Measure resistance between transmission connector and transmission ground.

Connector & terminal

(T4) No. 5 — Transmission ground:

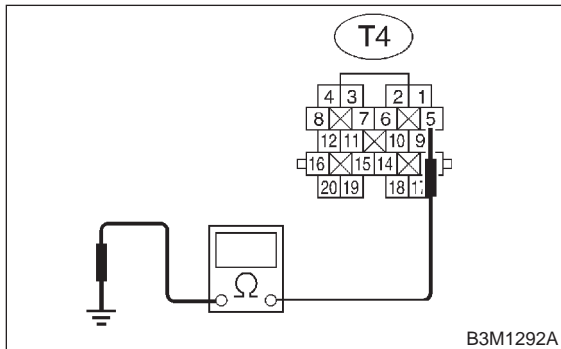

CHECK : *Is the resistance between 2.0 and 4.5 Ω ?*

YES : Go to step **8N8**.

NO : Go to step **8N17**.

8N8 : CHECK HARNESS CONNECTOR BETWEEN TCM AND TRANSMISSION.

Measure resistance of harness between TCM and transmission connector.

Connector & terminal

(B54) No. 9 — (B11) No. 5:

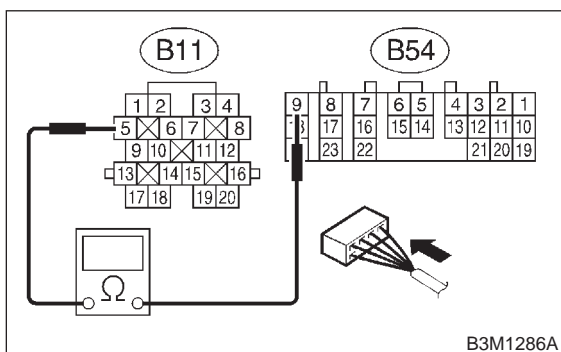

CHECK : *Is the resistance less than 1 Ω ?*

YES : Go to step **8N9**.

NO : Repair open circuit in harness between TCM and transmission connector.

8N9 : CHECK HARNESS CONNECTOR BETWEEN TCM AND CHASSIS GROUND.

Measure resistance of harness between TCM and chassis ground.

Connector & terminal

(B54) No. 9 — Chassis ground:

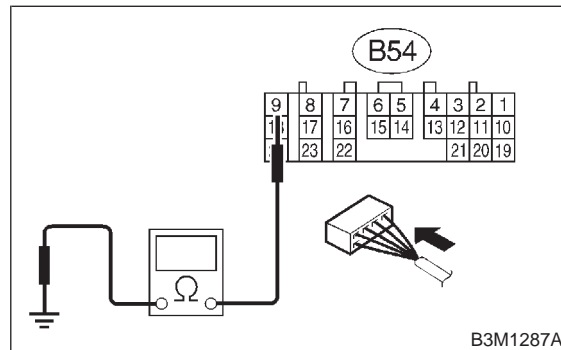

CHECK : *Is the resistance more than 1 $M\Omega$?*

YES : Go to step **8N10**.

NO : Repair short circuit in harness between TCM and transmission connector.

8N10 : PREPARE SUBARU SELECT MONITOR.

CHECK : *Do you have a Subaru Select Monitor?*

YES : Go to step **8N15**.

NO : Go to step **8N11**.

8N11 : CHECK OUTPUT SIGNAL EMITTED FROM TCM.

- 1) Connect all connectors.
- 2) Start the engine and warm-up the transmission until ATF temperature is above 80°C (176°F).

NOTE:

If ambient temperature is below 0°C (32°F), drive the vehicle until the ATF reaches its operating temperature.

- 3) Turn ignition switch to ON (engine OFF).
- 4) Move select lever to "N".
- 5) Measure voltage between TCM connector and chassis ground.

Connector & terminal

(B54) No. 9 (+) — Chassis ground (-):

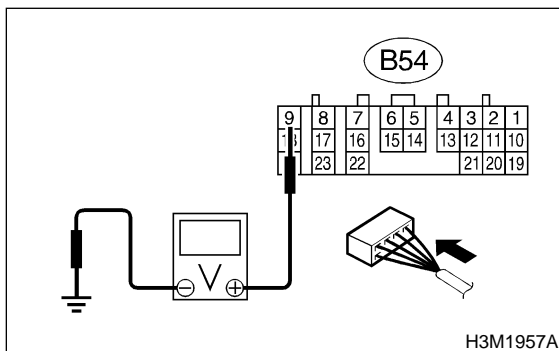

- CHECK** : *Is the voltage between 1.5 and 4.0 V with throttle fully closed?*
- YES** : Go to step **8N12**.
- NO** : Go to step **8N19**.

8N12 : CHECK OUTPUT SIGNAL EMITTED FROM TCM.

Measure voltage between TCM connector and chassis ground.

Connector & terminal

(B54) No. 9 (+) — Chassis ground (-):

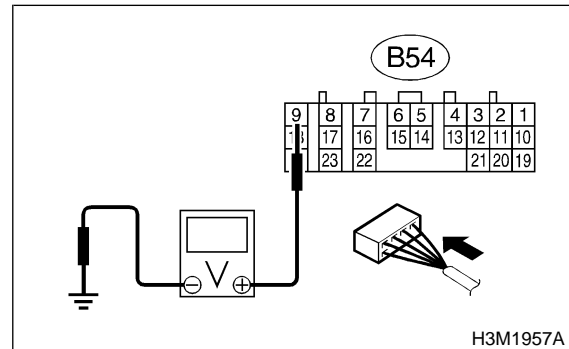

- CHECK** : *Is the voltage less than 1 V with throttle fully open?*
- YES** : Go to step **8N13**.
- NO** : Go to step **8N19**.

8N13 : CHECK OUTPUT SIGNAL EMITTED FROM TCM.

Measure voltage between TCM connector and chassis ground.

Connector & terminal

(B54) No. 18 (+) — Chassis ground (-):

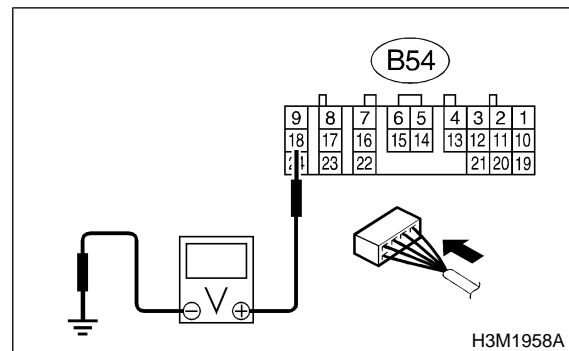

- CHECK** : *Is the voltage more than 8.5 V with throttle fully closed?*
- YES** : Go to step **8N14**.
- NO** : Go to step **8N19**.

8N14 : CHECK OUTPUT SIGNAL EMITTED FROM TCM.

Measure voltage between TCM connector and chassis ground.

Connector & terminal

(B54) No. 18 (+) — Chassis ground (-):

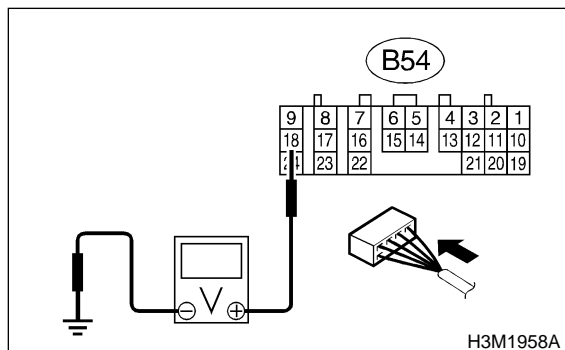

CHECK : **Is the voltage less than 1 V with throttle fully open?**

YES : Even if "AT OIL TEMP" lights up, the circuit has returned to a normal condition at this time. A temporary poor contact of the connector or harness may be the cause. Repair harness or connector in TCM.

NO : Go to step **8N19**.

8N15 : CHECK OUTPUT SIGNAL EMITTED FROM TCM USING SUBARU SELECT MONITOR.

- 1) Connect connector to transmission.
- 2) Connect Subaru Select Monitor to data link connector.

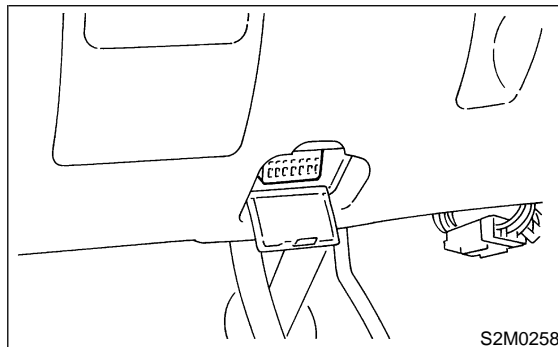

- 3) Start the engine, and turn Subaru Select Monitor switch to ON.
- 4) Warm-up the transmission until ATF temperature is above 80°C (176°F).

NOTE:

If ambient temperature is below 0°C (32°F), drive the vehicle until the ATF reaches its operating temperature.

- 5) Stop the engine and turn ignition switch to ON (engine OFF).
- 6) Move select lever to "N".
- 7) Read data of line pressure duty solenoid using Subaru Select Monitor.
 - Line pressure duty solenoid is indicated in "%".
- 8) Throttle is fully closed.

CHECK : **Is the value 100%?**

YES : Go to step **8N16**.

NO : Go to step **8N19**.

8N16 : CHECK OUTPUT SIGNAL EMITTED FROM TCM USING SUBARU SELECT MONITOR.

- 1) Turn ignition switch to ON (Engine OFF).
- 2) Throttle is fully open.

CHECK : **Is the value between 10 and 20%?**

YES : Even if "AT OIL TEMP" lights up, the circuit has returned to a normal condition at this time. A temporary poor contact of the connector or harness may be the cause. Repair harness or connector in TCM.

NO : Go to step **8N19**.

8N17 : CHECK LINE PRESSURE DUTY SOLENOID (IN TRANSMISSION).

- 1) Remove transmission connector from stay.
- 2) Lift-up or raise the vehicle and support with safety stand.

CAUTION:

On AWD models, raise all wheels off ground.

- 3) Drain automatic transmission fluid.

CAUTION:

Do not drain the automatic transmission fluid until it cools down.

- 4) Remove oil pan, and disconnect connector from line pressure duty solenoid.
- 5) Measure resistance between line pressure duty solenoid connector and transmission ground.

Connector & terminal

No. 1 — Transmission ground:

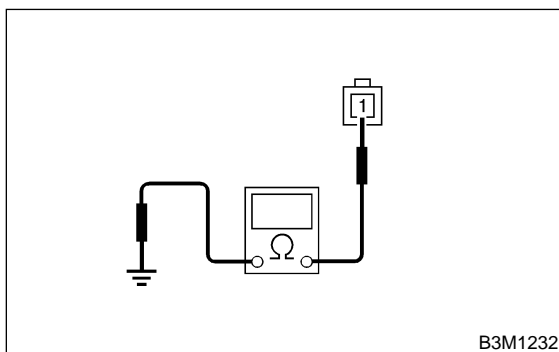

- CHECK** : **Is the resistance between 2.0 and 4.5 Ω?**
- YES** : Go to step **8N18**.
- NO** : Replace line pressure duty solenoid. <Ref. to 3-2 [W4A0].>

8N18 : CHECK HARNESS CONNECTOR BETWEEN TRANSMISSION AND LINE PRESSURE DUTY SOLENOID.

Measure resistance of harness between line pressure duty solenoid and transmission connector.

Connector & terminal

(T4) No. 5 — (AT2) No. 1:

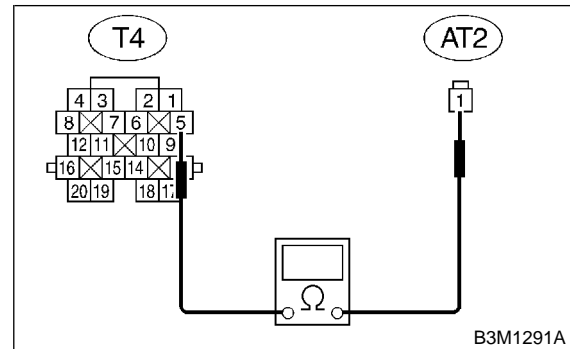

- CHECK** : **Is the resistance less than 1 Ω?**
- YES** : Go to step **8N19**.
- NO** : Repair open circuit in harness between line pressure duty solenoid and transmission connector.

8N19 : CHECK POOR CONTACT.

- CHECK** : **Is there poor contact in line pressure duty solenoid circuit?**
- YES** : Repair poor contact.
- NO** : Replace TCM. <Ref. to 3-2 [W23A0].>

O: TROUBLE CODE 76 — 2-4 BRAKE DUTY SOLENOID —

DIAGNOSIS:

Output signal circuit of 2-4 brake duty solenoid is open or shorted.

TROUBLE SYMPTOM:

Excessive shift shock.

WIRING DIAGRAM:

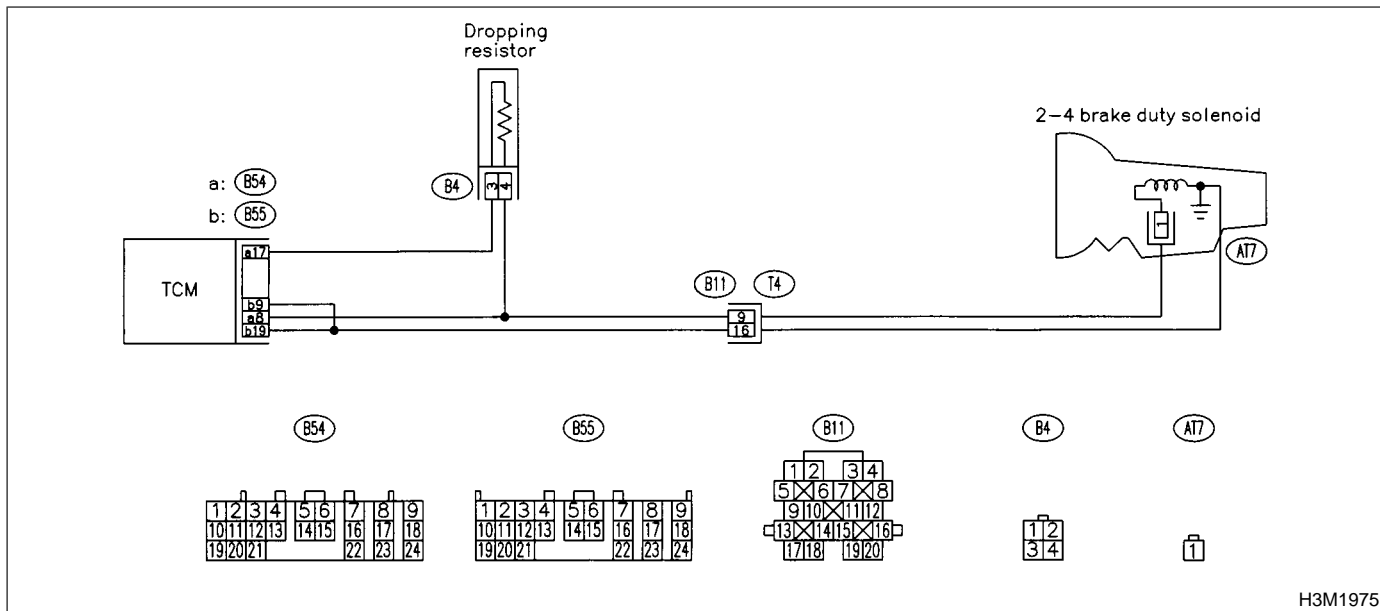

H3M1975

801 : CHECK RESISTOR.

- 1) Turn ignition switch to OFF.
- 2) Disconnect connector from dropping resistor.
- 3) Measure resistance between dropping resistor terminal.

Terminals

No. 3 — No. 4:

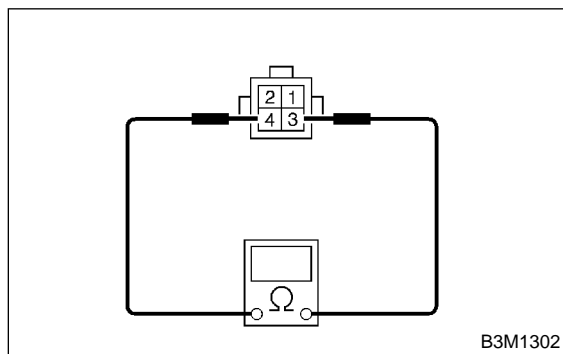

B3M1302

- CHECK** : Is the resistance between 9 and 15 Ω?
- YES** : Go to step 802.
- NO** : Replace dropping resistor. <Ref. to 3-2 [W24A0].>

802 : CHECK HARNESS CONNECTOR BETWEEN TCM AND DROPPING RESISTOR.

Measure resistance of harness between TCM connector and dropping resistor connector.

Connector & terminal

(B54) No. 17 — (B4) No. 3:

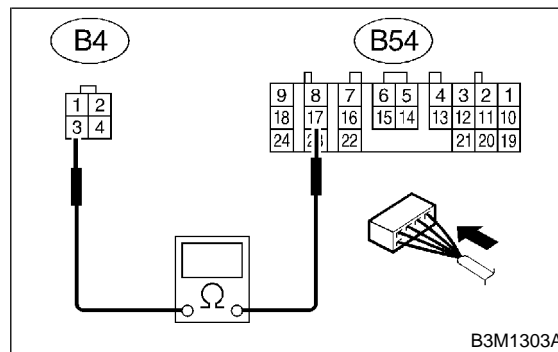

B3M1303A

- CHECK** : Is the resistance less than 1 Ω?
- YES** : Go to step 803.
- NO** : Repair open circuit in harness between TCM and dropping resistor connector.

803 : CHECK HARNESS CONNECTOR BETWEEN TCM AND DROPPING RESISTOR.

Measure resistance of harness between dropping resistor connector and chassis ground.

Connector & terminal

(B4) No. 3 — Chassis ground:

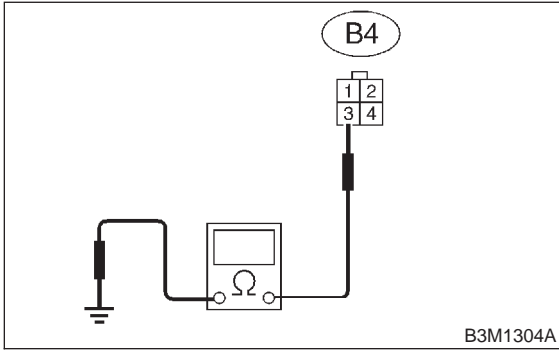

- CHECK** : **Is the resistance more than 1 MΩ?**
- YES** : Go to step **804**.
- NO** : Repair short circuit in harness between TCM and dropping resistor connector.

804 : CHECK HARNESS CONNECTOR BETWEEN TRANSMISSION AND DROPPING RESISTOR.

- 1) Disconnect connector from transmission.
- 2) Measure resistance of harness between transmission and dropping resistor connector.

Connector & terminal

(B4) No. 4 — (B11) No. 9:

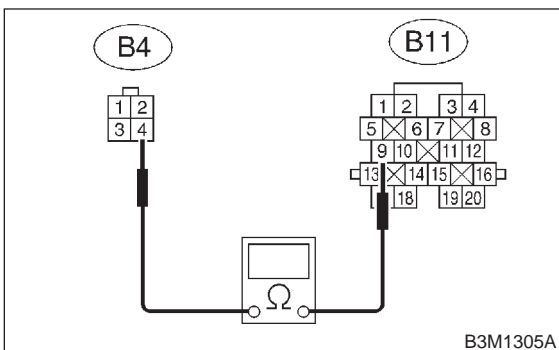

- CHECK** : **Is the resistance less than 1 Ω?**
- YES** : Go to step **805**.
- NO** : Repair open circuit in harness between dropping resistor and transmission connector.

805 : CHECK HARNESS CONNECTOR BETWEEN TRANSMISSION AND DROPPING RESISTOR.

Measure resistance of harness between dropping resistor connector and chassis ground.

Connector & terminal

(B4) No. 4 — Chassis ground:

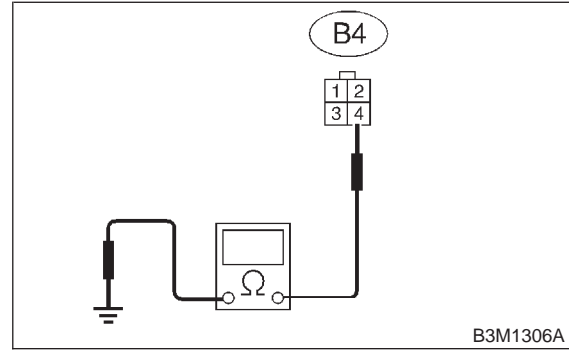

- CHECK** : **Is the resistance more than 1 MΩ?**
- YES** : Go to step **806**.
- NO** : Repair short circuit in harness between dropping resistor and transmission connector.

806 : CHECK 2-4 BRAKE DUTY SOLENOID GROUND LINE.

Measure resistance between transmission connector and transmission ground.

Connector & terminal

(T4) No. 16 — Transmission ground:

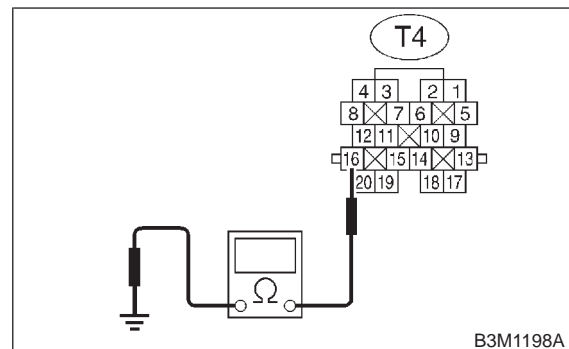

- CHECK** : **Is the resistance less than 1 Ω?**
- YES** : Go to step **807**.
- NO** : Repair open circuit in transmission harness.

807 : CHECK 2-4 BRAKE DUTY SOLENOID.

Measure resistance between transmission connector and transmission ground.

Connector & terminal

(T4) No. 9 — Transmission ground:

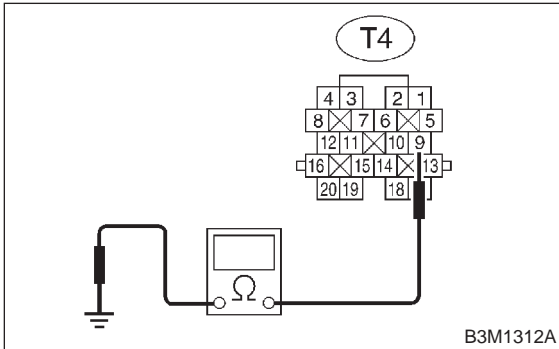

- CHECK** : *Is the resistance between 2.0 and 4.5 Ω ?*
- YES** : Go to step **808**.
- NO** : Go to step **8017**.

808 : CHECK HARNESS CONNECTOR BETWEEN TCM AND TRANSMISSION.

Measure resistance of harness between TCM and transmission connector.

Connector & terminal

(B54) No. 8 — (B11) No. 9:

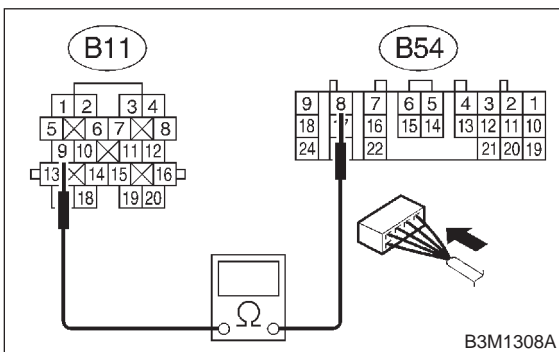

- CHECK** : *Is the resistance less than 1 Ω ?*
- YES** : Go to step **809**.
- NO** : Repair open circuit in harness between TCM and transmission connector.

809 : CHECK HARNESS CONNECTOR BETWEEN TCM AND CHASSIS GROUND.

Measure resistance of harness between TCM and chassis ground.

Connector & terminal

(B54) No. 8 — Chassis ground:

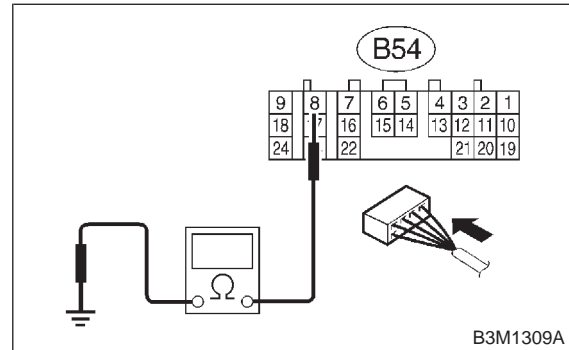

- CHECK** : *Is the resistance more than 1 $M\Omega$?*
- YES** : Go to step **8010**.
- NO** : Repair short circuit in harness between TCM and transmission connector.

8010 : PREPARE SUBARU SELECT MONITOR.

- CHECK** : *Do you have a Subaru Select Monitor?*
- YES** : Go to step **8015**.
- NO** : Go to step **8011**.

8011 : CHECK OUTPUT SIGNAL EMITTED FROM TCM.

- 1) Connect all connectors.
- 2) Start the engine and warm-up the transmission until ATF temperature is above 80°C (176°F).

NOTE:

If ambient temperature is below 0°C (32°F), drive the vehicle until the ATF reaches its operating temperature.

- 3) Turn ignition switch to ON (engine OFF).
- 4) Move select lever to "N".
- 5) Measure voltage between TCM connector and chassis ground.

Connector & terminal

(B54) No. 8 (+) — Chassis ground (-):

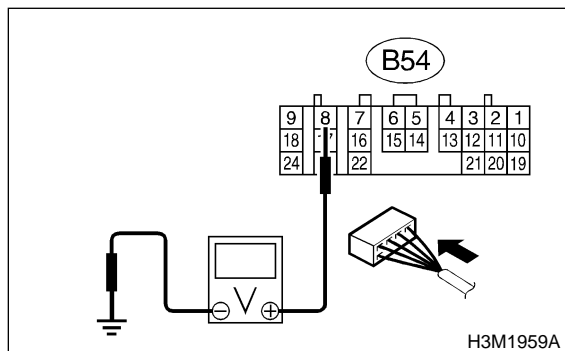

CHECK : *Is the voltage between 1.5 and 4.0 V with throttle fully closed?*

YES : Go to step 8012.

NO : Go to step 8019.

8012 : CHECK OUTPUT SIGNAL EMITTED FROM TCM.

Measure voltage between TCM connector and chassis ground.

Connector & terminal

(B54) No. 8 (+) — Chassis ground (-):

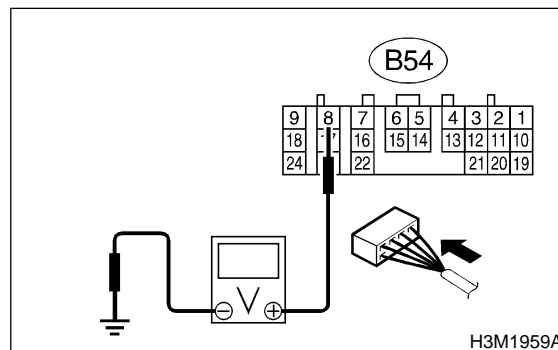

CHECK : *Is the voltage less than 1 V with throttle fully open?*

YES : Go to step 8013.

NO : Go to step 8019.

8013 : CHECK OUTPUT SIGNAL EMITTED FROM TCM.

Measure voltage between TCM connector and chassis ground.

Connector & terminal

(B54) No. 17 (+) — Chassis ground (-):

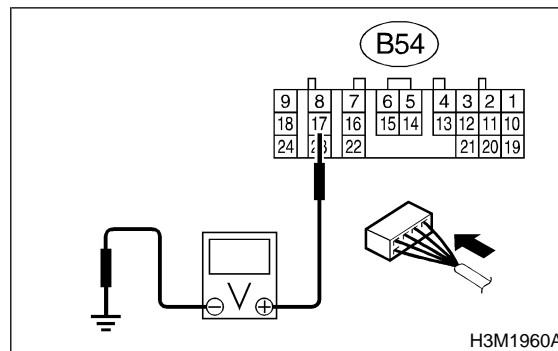

CHECK : *Is the voltage more than 8.5 V with throttle fully closed?*

YES : Go to step 8014.

NO : Go to step 8019.

8014 : CHECK OUTPUT SIGNAL EMITTED FROM TCM.

Measure voltage between TCM connector terminal and chassis ground.

Connector & terminal

(B54) No. 17 (+) — Chassis ground (-):

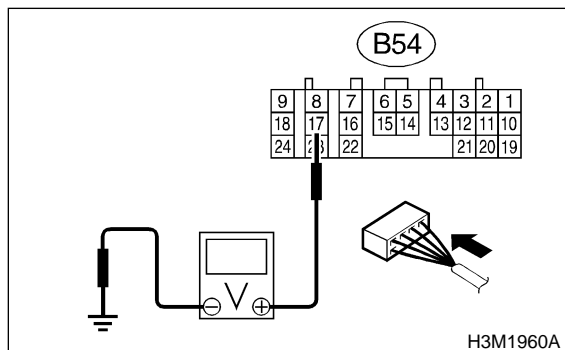

CHECK : **Is the voltage less than 1 V with throttle fully open?**

YES : Even if "AT OIL TEMP" lights up, the circuit has returned to a normal condition at this time. A temporary poor contact of the connector or harness may be the cause. Repair harness or connector in TCM.

NO : Go to step **8019**.

8015 : CHECK OUTPUT SIGNAL EMITTED FROM TCM USING SUBARU SELECT MONITOR.

- 1) Connect all connectors.
- 2) Connect Subaru Select Monitor to data link connector.

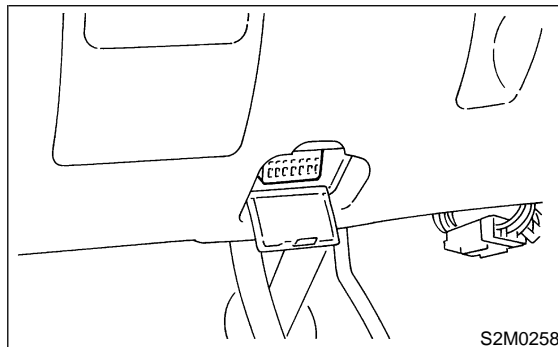

- 3) Start the engine, and turn Subaru Select Monitor switch to ON.
- 4) Warm-up the transmission until ATF temperature is above 80°C (176°F).

NOTE:

If ambient temperature is below 0°C (32°F), drive the vehicle until the ATF reaches its operating temperature.

- 5) Stop the engine and turn ignition switch to ON (engine OFF).
- 6) Move select lever to "N".
- 7) Read data of 2-4 brake duty solenoid using Subaru Select Monitor.
 - 2-4 brake duty is indicated in "%".
- 8) Throttle is fully closed.

CHECK : **Is the value 100%?**

YES : Go to step **8016**.

NO : Go to step **8019**.

8016 : CHECK OUTPUT SIGNAL EMITTED FROM TCM USING SUBARU SELECT MONITOR.

- 1) Turn ignition switch to ON (Engine OFF).
- 2) Throttle is fully open.

CHECK : **Is the value between 10 and 20%?**

YES : Even if "AT OIL TEMP" lights up, the circuit has returned to a normal condition at this time. A temporary poor contact of the connector or harness may be the cause. Repair harness or connector in TCM.

NO : Go to step **8019**.

8017 : CHECK 2-4 BRAKE DUTY SOLENOID (IN TRANSMISSION).

- 1) Remove transmission connector from stay.
- 2) Lift-up or raise the vehicle and support with safety stand.

CAUTION:

On AWD models, raise all wheels off ground.

- 3) Drain automatic transmission fluid.

CAUTION:

Do not drain the automatic transmission fluid until it cools down.

- 4) Remove oil pan, and disconnect connector from 2-4 brake duty solenoid.
- 5) Measure resistance between 2-4 brake duty solenoid connector and transmission ground.

Connector & terminal

No. 1 — Transmission ground:

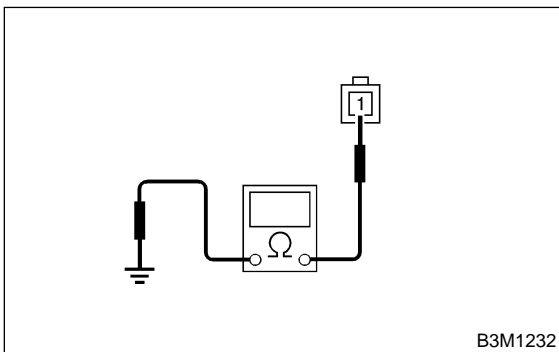

- CHECK** : **Is the resistance between 2.0 and 4.5 Ω?**
- YES** : Go to step **8018**.
- NO** : Replace 2-4 brake duty solenoid. <Ref. to 3-2 [W4A0].>

8018 : CHECK HARNESS CONNECTOR BETWEEN TRANSMISSION AND 2-4 BRAKE DUTY SOLENOID.

Measure resistance of harness between 2-4 brake duty solenoid and transmission connector.

Connector & terminal

(T4) No. 9 — (AT7) No. 1:

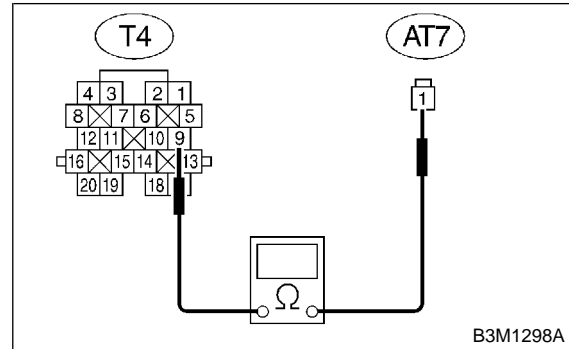

- CHECK** : **Is the resistance less than 1 Ω?**
- YES** : Go to step **8019**.
- NO** : Repair open circuit in harness between 2-4 brake duty solenoid and transmission connector.

8019 : CHECK POOR CONTACT.

- CHECK** : **Is there poor contact in 2-4 brake duty solenoid circuit?**
- YES** : Repair poor contact.
- NO** : Replace TCM. <Ref. to 3-2 [W23A0].>

P: TROUBLE CODE 77 — LOCK-UP DUTY SOLENOID —

DIAGNOSIS:

Output signal circuit of lock-up duty solenoid is open or shorted.

TROUBLE SYMPTOM:

No "lock-up" (after engine warm-up).

WIRING DIAGRAM:

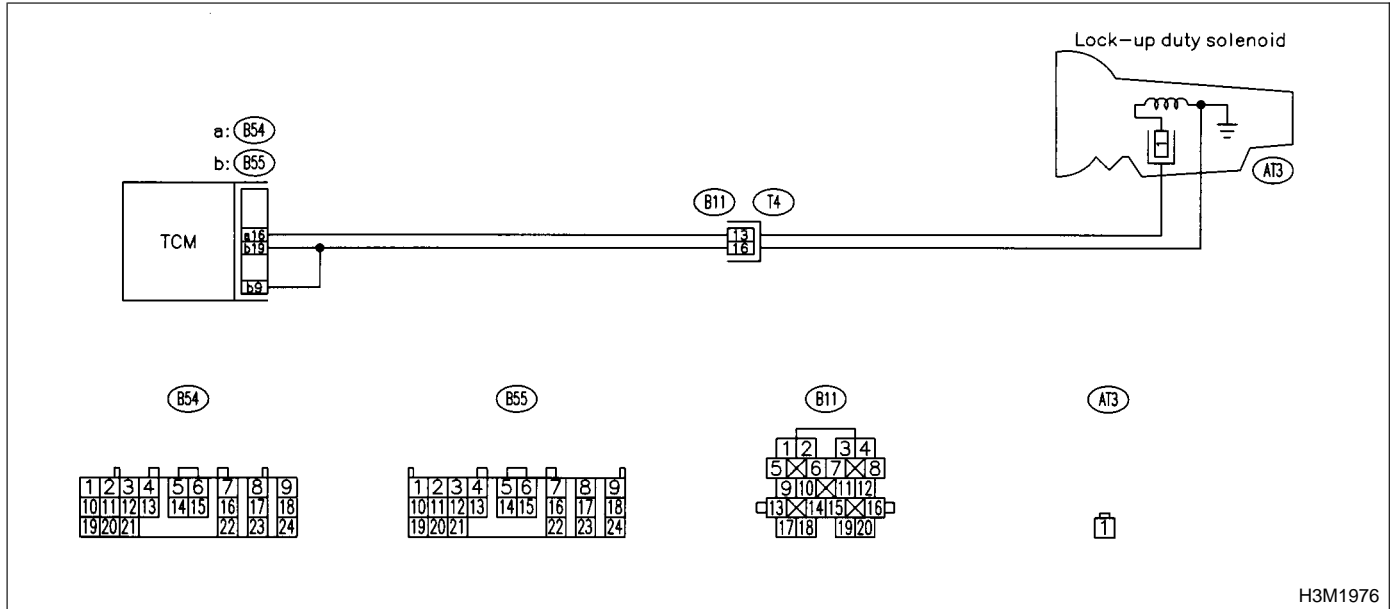

H3M1976

8P1 : CHECK TROUBLE CODE.

- CHECK** : Do multiple trouble codes appear in the on-board diagnostics test mode?
- YES** : Go to another trouble code.
- NO** : Go to step **8P2**.

8P2 : CHECK LOCK-UP DUTY SOLENOID GROUND LINE.

- 1) Turn ignition switch to OFF.
- 2) Disconnect connector from transmission.
- 3) Measure resistance between transmission connector and transmission ground.

Connector & terminal

(T4) No. 16 — Transmission ground:

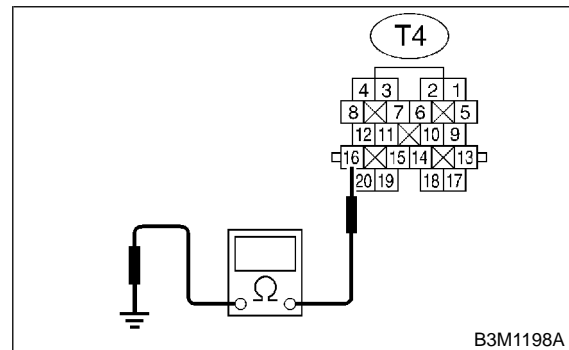

B3M1198A

- CHECK** : Is the resistance less than 1 Ω?
- YES** : Go to step **8P3**.
- NO** : Repair open circuit in transmission harness.

8P3 : CHECK LOCK-UP DUTY SOLENOID.

Measure resistance between transmission connector receptacle's terminals.

Connector & terminal
(T4) No. 13 — No. 16

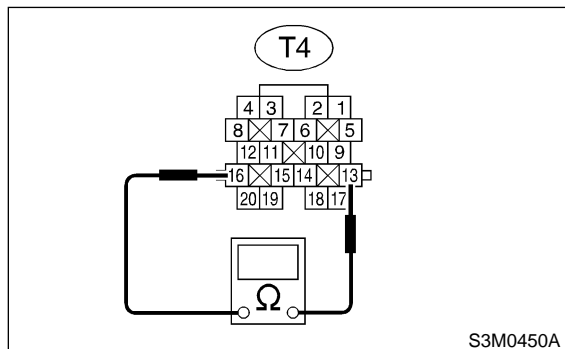

- CHECK** : Is the resistance between 10 and 17 Ω?
- YES** : Go to step 8P4.
- NO** : Go to step 8P11.

8P4 : CHECK HARNESS CONNECTOR BETWEEN TCM AND TRANSMISSION.

Measure resistance of harness connector between TCM and transmission.

Connector & terminal
(B54) No. 16 — (B11) No. 13:

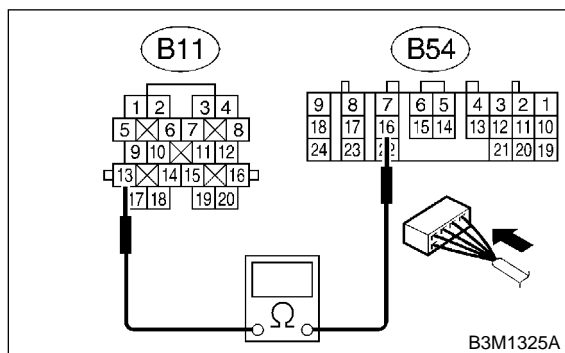

- CHECK** : Is the resistance less than 1 Ω?
- YES** : Go to step 8P5.
- NO** : Repair open circuit in harness between TCM and transmission connector.

8P5 : CHECK HARNESS CONNECTOR BETWEEN TCM AND CHASSIS GROUND.

Measure resistance of harness connector between TCM and chassis ground.

Connector & terminal
(B54) No. 16 — Chassis ground:

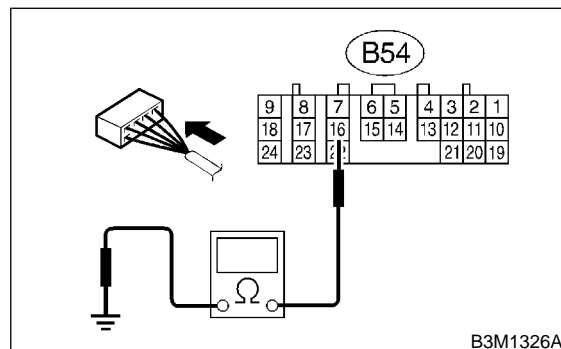

- CHECK** : Is the resistance more than 1 MΩ?
- YES** : Go to step 8P6.
- NO** : Repair short circuit in harness between TCM and transmission connector.

8P6 : PREPARE SUBARU SELECT MONITOR.

- CHECK** : Do you have a Subaru Select Monitor?
- YES** : Go to step 8P9.
- NO** : Go to step 8P7.

8P7 : CHECK OUTPUT SIGNAL EMITTED FROM TCM.

- 1) Connect connector to transmission.
- 2) Lift-up or raise the vehicle and support with safety stand.

CAUTION:

On AWD models, raise all wheels off ground.

- 3) Start the engine and warm-up the transmission until ATF temperature is above 80°C (176°F).

NOTE:

If ambient temperature is below 0°C (32°F), drive the vehicle until the ATF reaches its operating temperature.

- 4) Move select lever to "D" and slowly increase vehicle speed to 75 km/h (47 MPH). Wheels will lock-up.

NOTE:

The speed difference between front and rear wheels may light the ABS warning light, but this indicates no malfunction. When AT control diagnosis is finished, perform the ABS memory clearance procedure of on-board diagnostics system. <Ref. to 4-4 [T6D2].>

- 5) Measure voltage between TCM connector and chassis ground.

Connector & terminal

(B54) No. 16 (+) — Chassis ground (-):

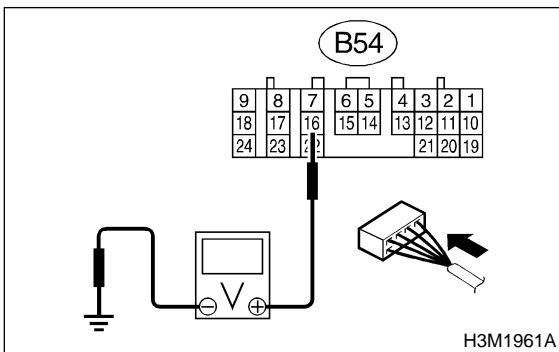

- CHECK** : **Is the voltage more than 8.5 V?**
- YES** : Go to step **8P8**.
- NO** : Go to step **8P13**.

8P8 : CHECK OUTPUT SIGNAL EMITTED FROM TCM.

- 1) Return the engine to idling speed and move select lever to "N".
- 2) Measure voltage between TCM connector and chassis ground.

Connector & terminal

(B54) No. 16 (+) — Chassis ground (-):

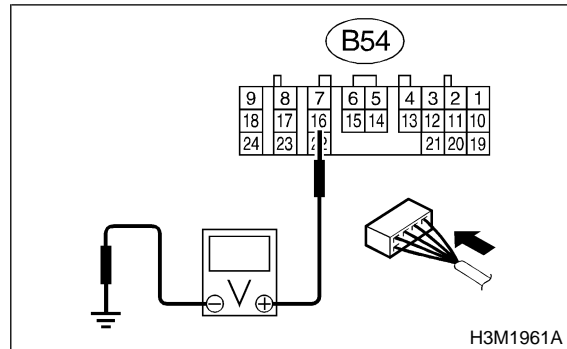

- CHECK** : **Is the voltage less than 0.5 V?**
- YES** : Even if "AT OIL TEMP" lights up, the circuit has returned to a normal condition at this time. A temporary poor contact of the connector or harness may be the cause. Repair harness or connector in TCM.
- NO** : Go to step **8P13**.

8P9 : CHECK OUTPUT SIGNAL EMITTED FROM TCM USING SUBARU SELECT MONITOR.

- 1) Connect connector to transmission.
- 2) Lift-up or raise the vehicle and support with safety stand.

CAUTION:

On AWD models, raise all wheels off ground.

- 3) Connect Subaru Select Monitor to data link connector.

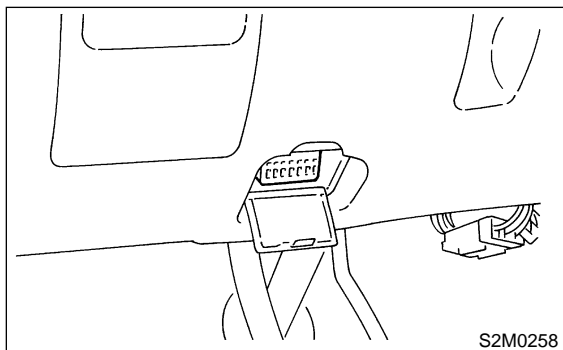

- 4) Start the engine, and turn Subaru Select Monitor switch to ON.
- 5) Start the engine and warm-up the transmission until ATF temperature is above 80°C (176°F).

NOTE:

If ambient temperature is below 0°C (32°F), drive the vehicle until the ATF reaches its operating temperature.

- 6) Read data of lock-up duty solenoid using Subaru Select Monitor.

- Lock-up duty is indicated in “%”.

- 7) Move select lever to “D” and slowly increase vehicle speed to 75 km/h (47 MPH). Wheels will lock-up.

NOTE:

The speed difference between front and rear wheels may light the ABS warning light, but this indicates no malfunction. When AT control diagnosis is finished, perform the ABS memory clearance procedure of on-board diagnostics system. <Ref. to 4-4 [T6D2].>

CHECK : **Is the value 95%?**

YES : Go to step **8P10**.

NO : Go to step **8P13**.

8P10 : CHECK OUTPUT SIGNAL EMITTED FROM TCM USING SUBARU SELECT MONITOR.

Return the engine to idling speed and move select lever to “N”.

NOTE:

The speed difference between front and rear wheels may light the ABS warning light, but this indicates no malfunction. When AT control diagnosis is finished, perform the ABS memory clearance procedure of on-board diagnostics system. <Ref. to 4-4 [T6D2].>

CHECK : **Is the value 5%?**

YES : Even if “AT OIL TEMP” lights up, the circuit has returned to a normal condition at this time. A temporary poor contact of the connector or harness may be the cause. Repair harness or connector in TCM.

NO : Go to step **8P13**.

8P11 : CHECK LOCK-UP DUTY SOLENOID (IN TRANSMISSION).

- 1) Remove transmission connector from stay.
- 2) Lift-up or raise the vehicle and support with safety stand.

CAUTION:

On AWD models, raise all wheels off ground.

- 3) Drain automatic transmission fluid.

CAUTION:

Do not drain the automatic transmission fluid until it cools down.

- 4) Remove oil pan, and disconnect connector from lock-up duty solenoid.
- 5) Measure resistance between lock-up duty solenoid connector and transmission ground.

Connector & terminal

No. 1 — Transmission ground:

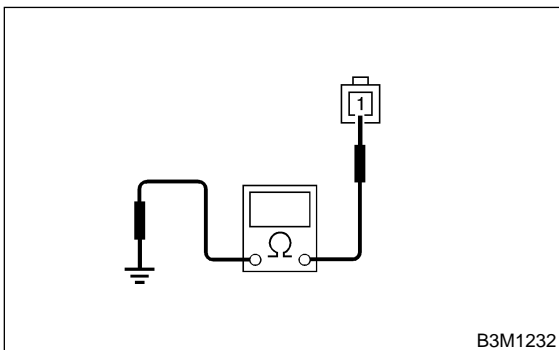

- CHECK** : **Is the resistance between 10 and 17 Ω ?**
- YES** : Go to step **8P12**.
- NO** : Replace lock-up duty solenoid. <Ref. to 3-2 [W4A0].>

8P12 : CHECK HARNESS CONNECTOR BETWEEN LOCK-UP DUTY SOLENOID AND TRANSMISSION.

Measure resistance of harness between lock-up duty solenoid and transmission connector.

Connector & terminal

(T4) No. 13 — (AT3) No. 1:

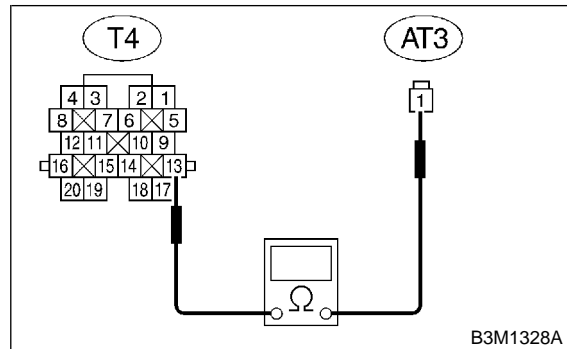

- CHECK** : **Is the resistance less than 1 Ω ?**
- YES** : Go to step **8P13**.
- NO** : Repair open circuit in harness between lock-up duty solenoid and transmission connector.

8P13 : CHECK POOR CONTACT.

- CHECK** : **Is there poor contact in lock-up duty solenoid circuit?**
- YES** : Repair poor contact.
- NO** : Replace TCM. <Ref. to 3-2 [W23A0].>

MEMO:

Q: TROUBLE CODE 79 — TRANSFER DUTY SOLENOID —

DIAGNOSIS:

Output signal circuit of transfer duty solenoid is open or shorted.

TROUBLE SYMPTOM:

Excessive “braking” in tight corners.

WIRING DIAGRAM:

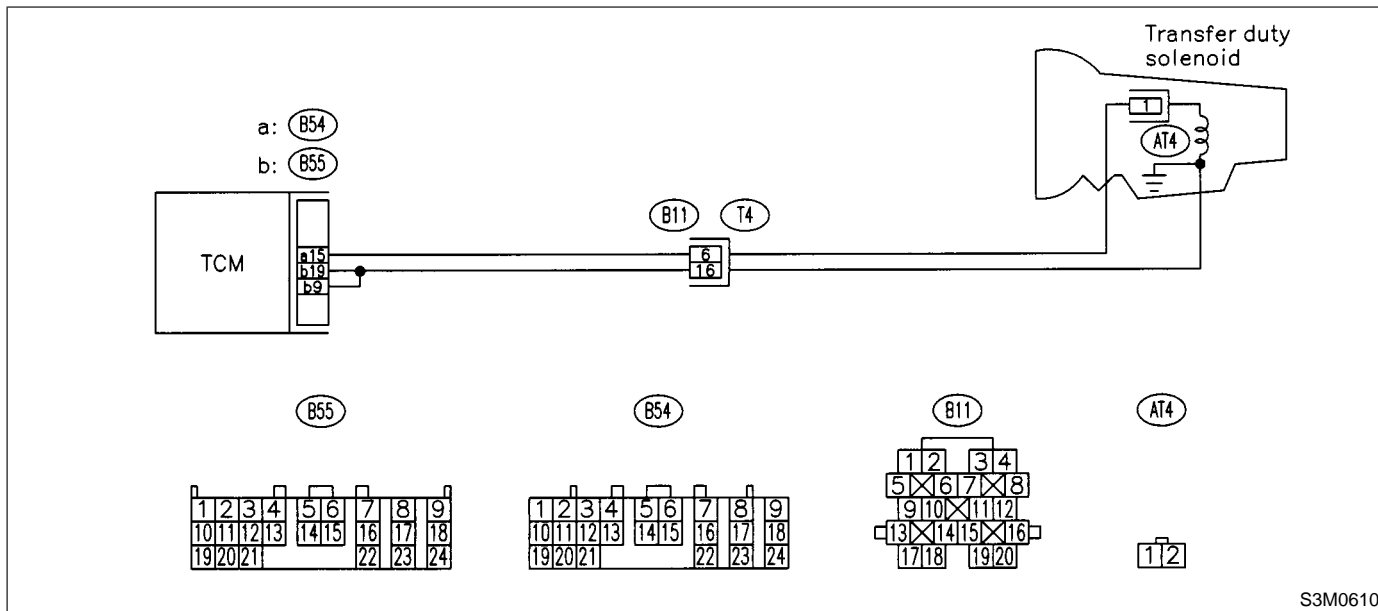

8Q1 : CHECK TRANSFER DUTY SOLENOID GROUND LINE.

- 1) Turn ignition switch to OFF.
- 2) Disconnect connector from transmission.
- 3) Measure resistance between transmission connector and transmission ground.

Connector & terminal

(T4) No. 16 — Transmission ground:

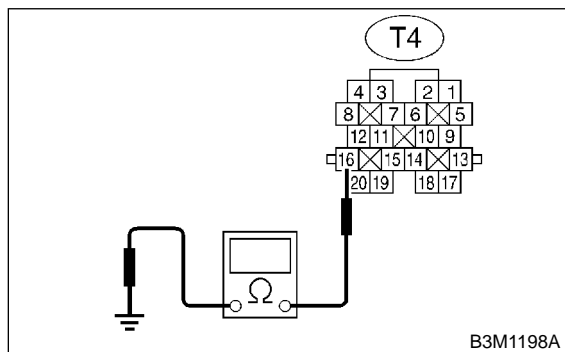

- CHECK** : Is the resistance less than 1 Ω?
- YES** : Go to step 8Q2.
- NO** : Repair open circuit in transmission harness.

8Q2 : CHECK TRANSFER DUTY SOLENOID.

Measure resistance between transmission connector and transmission ground.

Connector & terminal

(T4) No. 6 — Transmission ground:

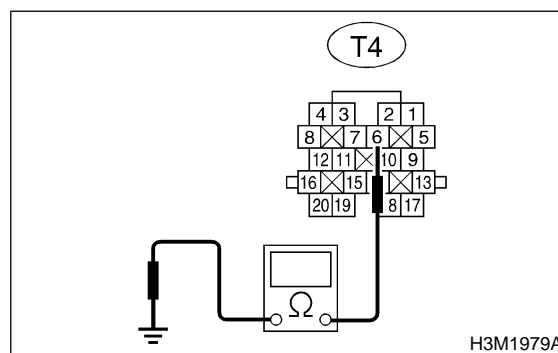

- CHECK** : Is the resistance between 10 and 17 Ω?
- YES** : Go to step 8Q3.
- NO** : Go to step 8Q10.

8Q3 : CHECK HARNESS CONNECTOR BETWEEN TCM AND TRANSMISSION.

Measure resistance of harness between TCM and transmission connector.

Connector & terminal

(B54) No. 15 — (B11) No. 6:

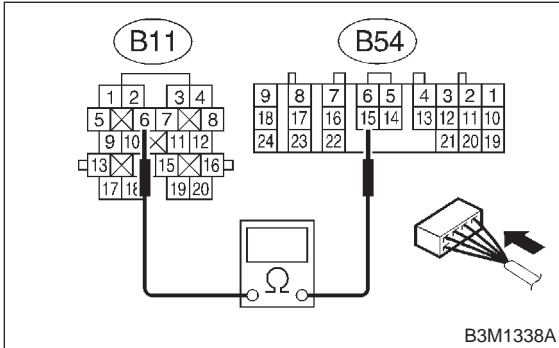

- CHECK** : *Is the resistance less than 1 Ω?*
- YES** : Go to step **8Q4**.
- NO** : Repair open circuit in harness between TCM and transmission connector.

8Q4 : CHECK HARNESS CONNECTOR BETWEEN TCM AND TRANSMISSION.

Measure resistance harness connector between TCM and chassis ground.

Connector & terminal

(B54) No. 15 — Chassis ground:

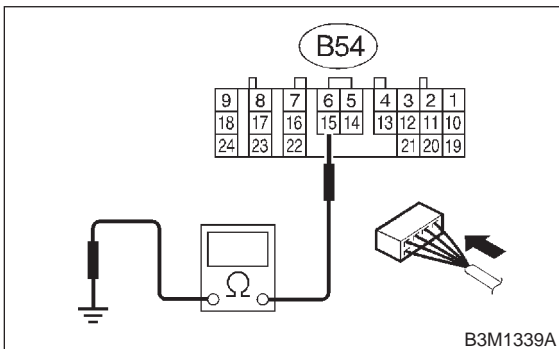

- CHECK** : *Is the resistance more than 1 MΩ?*
- YES** : Go to step **8Q5**.
- NO** : Repair short circuit in harness between TCM and transmission connector.

8Q5 : PREPARE SUBARU SELECT MONITOR.

- CHECK** : *Do you have a Subaru Select Monitor?*
- YES** : Go to step **8Q8**.
- NO** : Go to step **8Q6**.

8Q6 : CHECK OUTPUT SIGNAL EMITTED FROM TCM.

- 1) Connect connectors to transmission.
- 2) Turn ignition switch to ON (engine OFF).
- 3) Throttle is fully closed.
- 4) Measure voltage between TCM connector and chassis ground.

Connector & terminal

(B54) No. 15 (+) — Chassis ground (-):

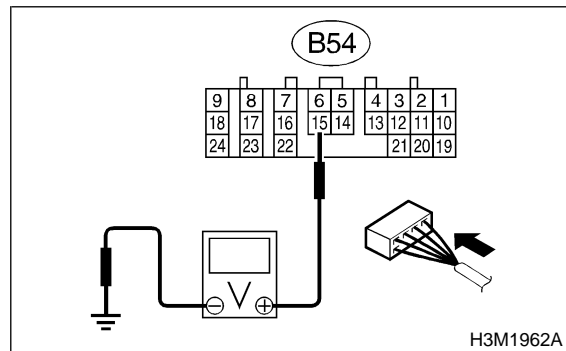

- CHECK** : *Is the voltage less than 1 V in “P” range?*
- YES** : Go to step **8Q7**.
- NO** : Go to step **8Q12**.

8Q7 : CHECK OUTPUT SIGNAL EMITTED FROM TCM.

Measure voltage between TCM connector and chassis ground.

Connector & terminal

(B54) No. 15 (+) — Chassis ground (-):

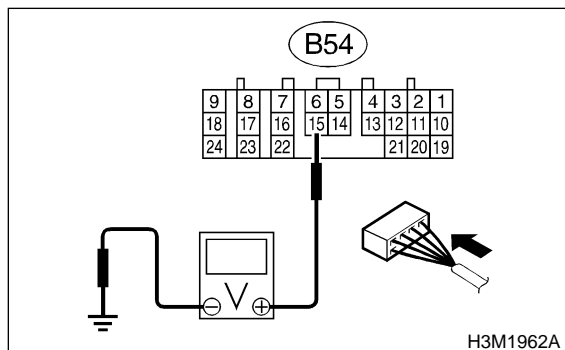

CHECK : **Is the voltage between 5 and 7 V in "D" range?**

YES : Even if "AT OIL TEMP" lights up, the circuit has returned to a normal condition at this time. A temporary poor contact of the connector or harness may be the cause. Repair harness or connector in the transfer duty solenoid and TCM connector.

NO : Go to step **8Q12**.

8Q8 : CHECK OUTPUT SIGNAL EMITTED FROM TCM USING SUBARU SELECT MONITOR.

- 1) Connect connector to transmission.
- 2) Connect Subaru Select Monitor to data link connector.

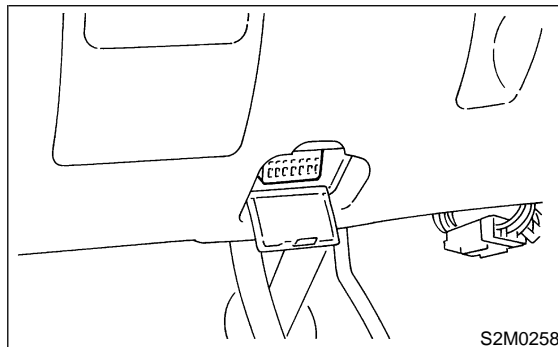

- 3) Turn ignition switch to ON (engine OFF) and turn Subaru Select Monitor switch to ON.
- 4) Move select lever to "D" with throttle fully open (vehicle speed 0 km/h or 0 MPH).
- 5) Read data of transfer duty solenoid using Subaru Select Monitor.

● Transfer duty solenoid is indicated in "%".

CHECK : **Is the value between 5 and 10%?**

YES : Go to step **8Q9**.

NO : Go to step **8Q12**.

8Q9 : CHECK OUTPUT SIGNAL EMITTED FROM TCM USING SUBARU SELECT MONITOR.

- 1) Set FWD mode.
- 2) Throttle fully closed.

CHECK : **Is the value 95%?**

YES : Even if "AT OIL TEMP" lights up, the circuit has returned to a normal condition at this time. A temporary poor contact of the connector or harness may be the cause. Repair harness or connector in the transfer duty solenoid and TCM connector.

NO : Go to step **8Q12**.

8Q10 : CHECK TRANSFER DUTY SOLENOID (IN TRANSMISSION).

1) Lift-up or raise the vehicle and support with safety stand.

CAUTION:

On AWD models, raise all wheels off ground.

2) Drain automatic transmission fluid.

CAUTION:

Do not drain the automatic transmission fluid until it cools down.

3) Remove extension case, and disconnect connector from transfer duty solenoid.

4) Measure resistance between transfer duty solenoid connector and transmission ground.

Connector & terminal

(AT4) No. 1 — Transmission ground:

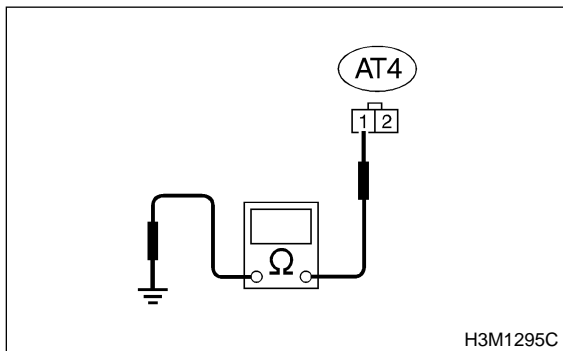

CHECK : Is the resistance between 10 and 17 Ω?

YES : Go to step 8Q11.

NO : Replace transfer duty solenoid. <Ref. to 3-2 [W5A0].>

8Q11 : CHECK HARNESS CONNECTOR BETWEEN TRANSFER DUTY SOLENOID AND TRANSMISSION.

Measure resistance of harness between transfer duty solenoid and transmission connector.

Connector & terminal

(T4) No. 6 — (AT4) No. 1:

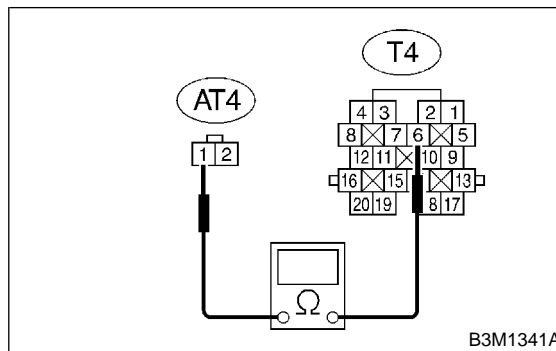

CHECK : Is the resistance less than 1 Ω?

YES : Go to step 8Q12.

NO : Repair open circuit in harness between transfer duty solenoid and transmission connector.

8Q12 : CHECK POOR CONTACT.

CHECK : Is there poor contact in transfer duty solenoid circuit?

YES : Repair poor contact.

NO : Replace TCM. <Ref. to 3-2 [W23A0].>

R: TROUBLE CODE 93 — VEHICLE SPEED SENSOR 1 (REAR) —

DIAGNOSIS:

Input signal circuit of TCM is open or shorted.

TROUBLE SYMPTOM:

No lock-up or excessive tight corner “braking”.

WIRING DIAGRAM:

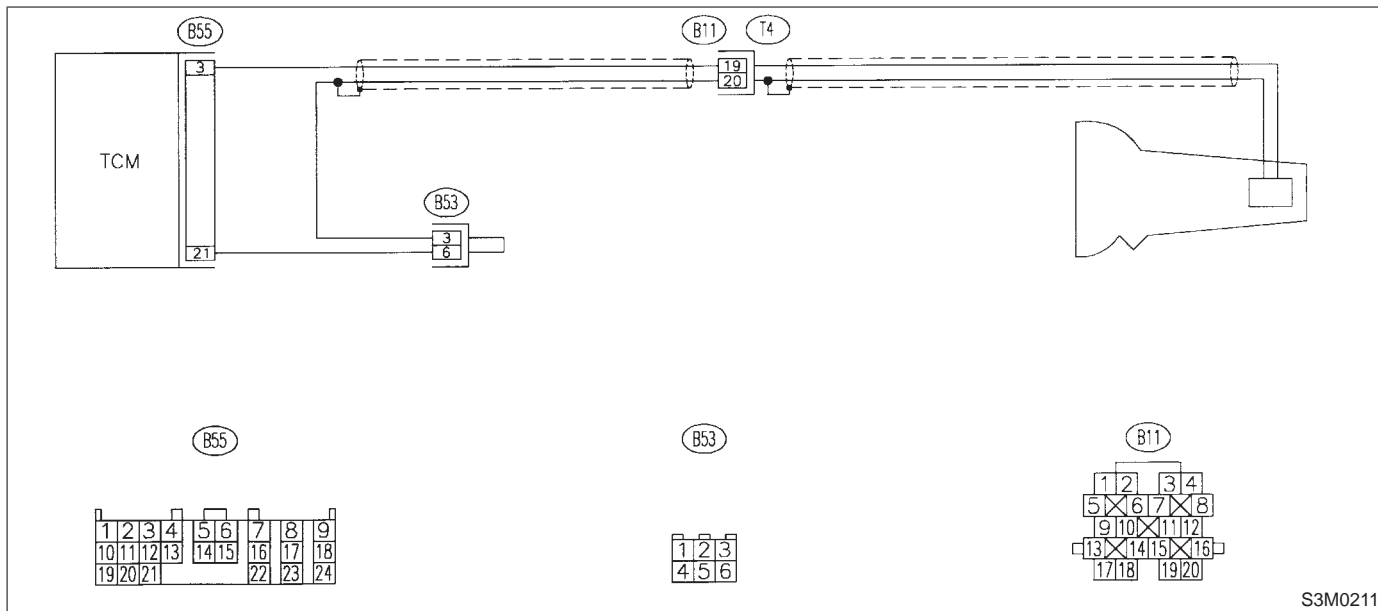

8R1 : CHECK VEHICLE SPEED SENSOR 1.

- 1) Turn ignition switch to OFF.
- 2) Disconnect connector from transmission.
- 3) Measure resistance between transmission connector receptacle's terminals.

Connector & terminal
(T4) No. 19 — No. 20:

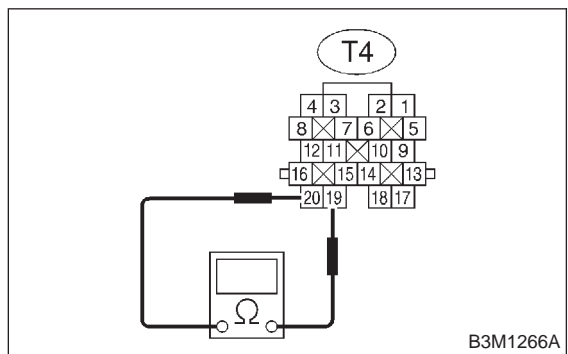

- CHECK** : Is the resistance between 450 and 650 Ω?
- YES** : Go to step 8R2.
- NO** : Replace transmission harness connector. <Ref. to 3-2 [W12A0].>

8R2 : CHECK HARNESS CONNECTOR BETWEEN TCM AND TRANSMISSION.

Measure resistance between TCM and transmission connector.

Connector & terminal
(B55) No. 3 — (B11) No. 19:

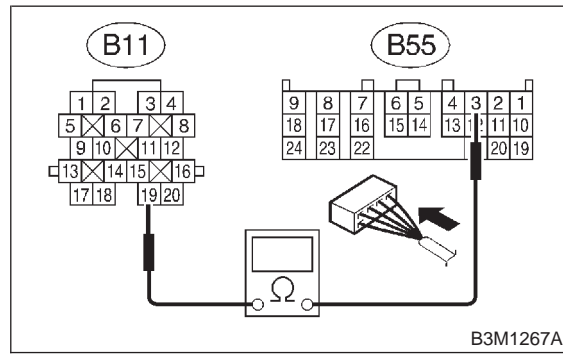

- CHECK** : Is the resistance less than 1 Ω?
- YES** : Go to step 8R3.
- NO** : Repair open circuit in harness between TCM and transmission connector.

8R3 : CHECK HARNESS CONNECTOR BETWEEN TCM AND TRANSMISSION.

Measure resistance of harness between TCM and transmission connector.

Connector & terminal

(B55) No. 21 — (B11) No. 20:

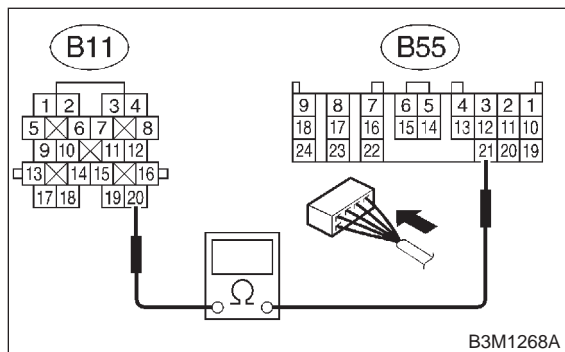

- CHECK** : *Is the resistance less than 1 Ω?*
- YES** : Go to step 8R4.
- NO** : Repair open circuit in harness between TCM and transmission, and poor contact in coupling connector.

8R4 : CHECK HARNESS CONNECTOR BETWEEN TCM AND TRANSMISSION.

Measure resistance of harness between TCM and chassis ground.

Connector & terminal

(B55) No. 3 — Chassis ground:

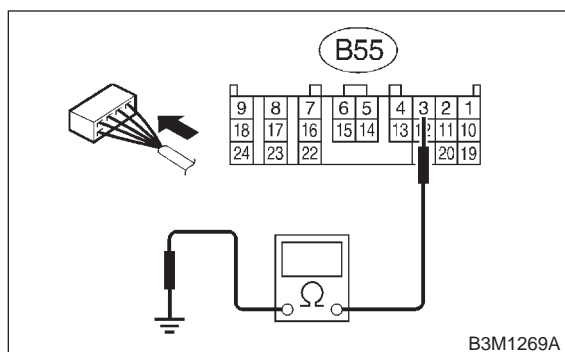

- CHECK** : *Is the resistance more than 1 MΩ?*
- YES** : Go to step 8R5.
- NO** : Repair short circuit in harness between TCM and transmission connector.

8R5 : CHECK HARNESS CONNECTOR BETWEEN TCM AND TRANSMISSION.

Measure resistance of harness between TCM and chassis ground.

Connector & terminal

(B55) No. 21 — Chassis ground:

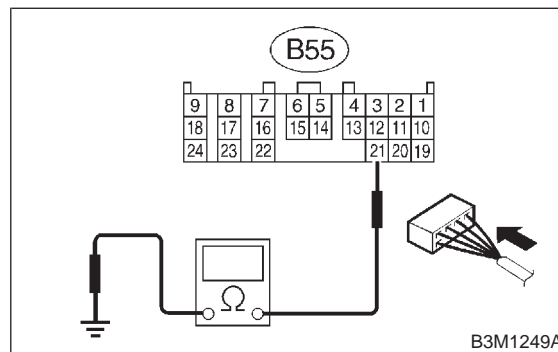

- CHECK** : *Is the resistance more than 1 MΩ?*
- YES** : Go to step 8R6.
- NO** : Repair short circuit in harness between TCM and transmission connector.

8R6 : PREPARE OSCILLOSCOPE.

- CHECK** : *Do you have oscilloscope?*
- YES** : Go to step 8R10.
- NO** : Go to step 8R7.

8R7 : PREPARE SUBARU SELECT MONITOR.

- CHECK** : *Do you have a Subaru Select Monitor?*
- YES** : Go to step 8R9.
- NO** : Go to step 8R8.

8R8 : CHECK INPUT SIGNAL FOR TCM.

- 1) Connect connector to transmission.
- 2) Lift-up or raise the vehicle and support with safety stand.

CAUTION:

On AWD models, raise all wheels off ground.

- 3) Start the engine and set vehicle in 20 km/h (12 MPH) condition.

NOTE:

The speed difference between front and rear wheels may light the ABS warning light, but this indicates no malfunction. When AT control diagnosis is finished, perform the ABS memory clearance procedure of on-board diagnostics system. <Ref. to 4-4 [T6D2].>

- 4) Measure voltage between TCM connector terminals.

Connector & terminal

(B55) No. 3 (+) — No. 21 (-):

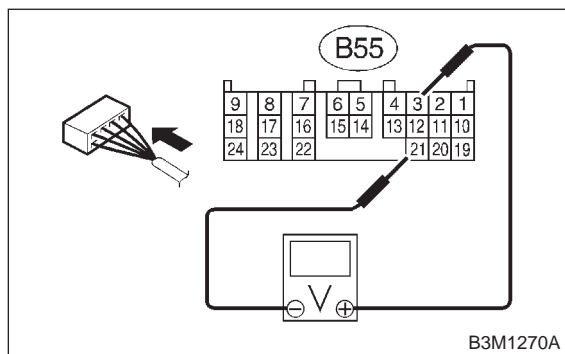

CHECK : **Is the voltage more than AC 1 V?**

YES : Even if "AT OIL TEMP" lights up, the circuit has returned to a normal condition at this time. A temporary poor contact of the connector or harness may be the cause. Repair harness or connector in the TCM and transmission.

NO : Go to step 8R11.

8R9 : CHECK INPUT SIGNAL FOR TCM USING SUBARU SELECT MONITOR.

- 1) Connect connector to transmission.
- 2) Connect Subaru Select Monitor to data link connector.

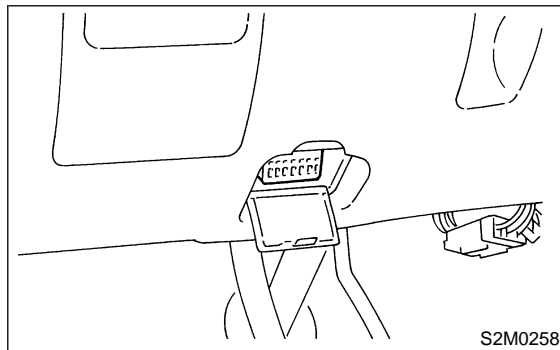

- 3) Lift-up or raise the vehicle and support with safety stand.

CAUTION:

On AWD models, raise all wheels off ground.

- 4) Turn ignition switch to ON and turn Subaru Select Monitor switch to ON.
- 5) Start the engine.
- 6) Read data of vehicle speed using Subaru Select Monitor.
 - Compare speedometer with Subaru Select Monitor indications.
 - Vehicle speed is indicated in "km/h" or "MPH".
- 7) Slowly increase vehicle speed to 60 km/h or 37 MPH.

NOTE:

The speed difference between front and rear wheels may light the ABS warning light, but this indicates no malfunction. When AT control diagnosis is finished, perform the ABS memory clearance procedure of on-board diagnostics system. <Ref. to 4-4 [T6D2].>

CHECK : **Does the speedometer indication increase as the Subaru Select Monitor data increases?**

YES : Even if "AT OIL TEMP" lights up, the circuit has returned to a normal condition at this time. A temporary poor contact of the connector or harness may be the cause. Repair harness or connector in the TCM and transmission.

NO : Go to step 8R11.

8R10 : CHECK INPUT SIGNAL FOR TCM USING OSCILLOSCOPE.

- 1) Connect connector to transmission.
- 2) Lift-up or raise the vehicle and support with safety stand.

CAUTION:

On AWD models, raise all wheels off ground.

- 3) Set oscilloscope to TCM connector terminals.
Position probe; (B55) No. 3
Earth lead; (B55) No. 21

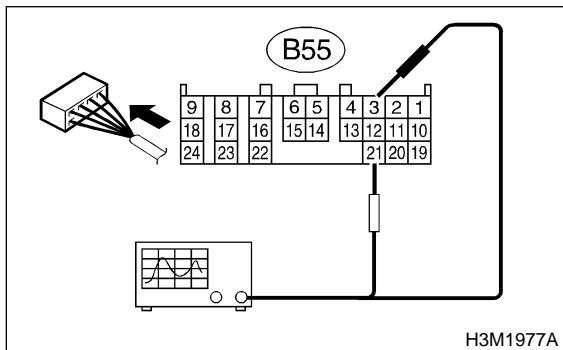

- 4) Start the engine and set vehicle in 20 km/h (12 MPH) condition.

NOTE:

The speed difference between front and rear wheels may light the ABS warning light, but this indicates no malfunction. When AT control diagnosis is finished, perform the ABS memory clearance procedure of on-board diagnostics system. <Ref. to 4-4 [T6D2].>

- 5) Measure signal voltage indicated on oscilloscope.

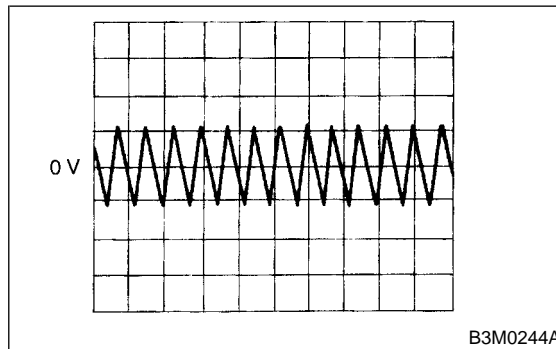

- CHECK** : *Is the signal voltage more than AC 1 V?*
- YES** : Even if "AT OIL TEMP" lights up, the circuit has returned to a normal condition at this time. A temporary poor contact of the connector or harness may be the cause. Repair harness or connector in the TCM and transmission.
- NO** : Go to step **8R11**.

8R11 : CHECK POOR CONTACT.

- CHECK** : *Is there poor contact in vehicle speed sensor 1 circuit?*
- YES** : Repair poor contact.
- NO** : Replace TCM. <Ref. to 3-2 [W23A0].>