

9. Diagnostic Chart with Select Monitor

A: BASIC DIAGNOSTIC CHART

If no trouble codes appear in the on-board diagnostics operation (although problems have occurred or are occurring), measure performance characteristics of sensors, actuators, etc., in the Subaru Select Monitor and compare with the "basic data" to determine the cause of problems.

- 1) Trouble occurs.
- 2) No trouble codes appear in on-board diagnostics operation.
- 3) Measure each item using Subaru Select Monitor.
- 4) Compare measured values with basic data.
- 5) Determine item which is outside basic data specifications.
- 6) Check sensor and actuator affected.

B: BATTERY VOLTAGE

9B1 : CHECK BATTERY VOLTAGE.

- 1) Turn ignition switch to OFF.
- 2) Connect Subaru Select Monitor to data link connector.

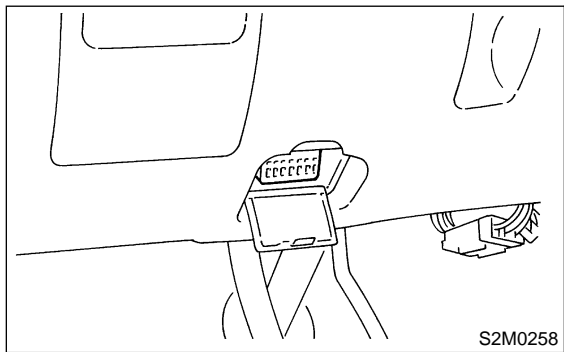

- 3) Start the engine, and engine idling after warm-up.
 - 4) Turn Subaru Select Monitor switch to ON.
 - 5) Read data of battery voltage using Subaru Select Monitor.
- Battery voltage applied to TCM.

CHECK : *Is voltage between 10 and 16 V?*

YES : Go to step VEHICLE SPEED SENSOR 1. <Ref. to 3-2 [T9C0].>

NO : Check battery voltage and specification of electrolyte, regulating voltage under no loads and generator (as a single unit).

C: CHECK VEHICLE SPEED SENSOR 1.

9C1 : CHECK VEHICLE SPEED SENSOR 1.

- 1) Lift-up or raise the vehicle and support with safety stand.

CAUTION:

On AWD models, raise all wheels off ground.

- 2) Read data of vehicle speed #1 using Subaru Select Monitor.

- Compare speedometer with Subaru Select Monitor indications.
- Vehicle speed is indicated in "MPH" or "km/h".

NOTE:

The speed difference between front and rear wheels may light the ABS warning light, but this indicates no malfunction. When AT control diagnosis is finished, perform the ABS memory clearance procedure of on-board diagnostics system. <Ref. to 4-4 [T6D2].>

CHECK : *Does the speedometer indication increase as the Subaru Select Monitor data increases?*

YES : Go to step VEHICLE SPEED SENSOR 2. <Ref. to 3-2 [T9D0].>

NO : Check vehicle speed sensor 1 circuit. <Ref. to 3-2 [T8R0].>

D: CHECK VEHICLE SPEED SENSOR 2.

9D1 : CHECK VEHICLE SPEED SENSOR 2.

Read data of vehicle speed #2 using Subaru Select Monitor.

- Compare speedometer with Subaru Select Monitor indications.
- Vehicle speed is indicated in "MPH" or "km/h".

NOTE:

The speed difference between front and rear wheels may light the ABS warning light, but this indicates no malfunction. When AT control diagnosis is finished, perform the ABS memory clearance procedure of on-board diagnostics system. <Ref. to 4-4 [T6D2].>

CHECK : *Does the speedometer indication increase as the Subaru Select Monitor data increases?*

YES : Go to step ENGINE SPEED SIGNAL. <Ref. to 3-2 [T9E0].>

NO : Check vehicle speed sensor 2 circuit. <Ref. to 3-2 [T8F0].>

E: CHECK ENGINE SPEED SIGNAL.**9E1 : CHECK ENGINE SPEED SIGNAL.**

- 1) Turn A/C switch to OFF (with A/C models).
- 2) Warm-up the engine until engine coolant temperature is above 80°C (176°F).

NOTE:

If ambient temperature is below 0°C (32°F), drive the vehicle until the ATF reaches its operating temperature.

- 3) Read data of engine speed using Subaru Select Monitor.

- Engine speed is indicated in “rpm”.

NOTE:

The speed difference between front and rear wheels may light the ABS warning light, but this indicates no malfunction. When AT control diagnosis is finished, perform the ABS memory clearance procedure of on-board diagnostics system. <Ref. to 4-4 [T6D2].>

CHECK : *Does the tachometer revolution increase as the Subaru Select Monitor revolution data increases?*

YES : Go to step ATF TEMPERATURE SENSOR. <Ref. to 3-2 [T9F0].>

NO : Check engine speed signal circuit. <Ref. to 3-2 [T8C0].>

F: CHECK ATF TEMPERATURE SENSOR.**9F1 : CHECK AT OIL TEMP WARNING LIGHT.**

CHECK : *Does the AT OIL TEMP warning light remain on 2 seconds after the engine has been started?*

YES : Go to step 9F2.

NO : Check ATF temperature sensor and combination meter circuit. <Ref. to 3-2 [T8D0].>

9F2 : CHECK ATF TEMPERATURE SENSOR.

- 1) Read data of ATF temperature using Subaru Select Monitor.

- ATF temperature is indicated in “°F” or “°C”.
- 2) Warm-up the transmission until ATF temperature is above 80°C (176°F).

NOTE:

If ambient temperature is below 0°C (32°F), drive the vehicle until the ATF reaches its operating temperature.

- 3) Turn ignition switch to ON (engine OFF).

CHECK : *Does the ATF temperature change from 176°F (80°C)?*

YES : Go to step THROTTLE POSITION SENSOR. <Ref. to 3-2 [T9G0].>

NO : Check ATF temperature sensor circuit. <Ref. to 3-2 [T8D0].>

G: CHECK THROTTLE POSITION SENSOR.**9G1 : CHECK INPUT SIGNAL FOR TCM.**

Read data of throttle position sensor using Subaru Select Monitor.

- Throttle position sensor input signal is indicated.

CHECK : *Is voltage between 0.3 and 0.7 V when the accelerator pedal is completely released?*

YES : Go to step 9G2.

NO : Check throttle position sensor circuit. <Ref. to 3-2 [T8E0].>

9G2 : CHECK INPUT SIGNAL FOR TCM.

CHECK : *Is voltage between 4.3 and 4.9 V when the accelerator pedal is completely depressed?*

YES : Go to step 9G3.

NO : Check throttle position sensor circuit. <Ref. to 3-2 [T8E0].>

9G3 : CHECK INPUT SIGNAL FOR TCM.

CHECK : *Does voltage decrease smoothly when the accelerator pedal is fully depressed and then fully released?*

YES : Go to step GEAR POSITION. <Ref. to 3-2 [T9H0].>

NO : Check throttle position sensor circuit. <Ref. to 3-2 [T8E0].>

H: CHECK GEAR POSITION.**9H1 : CHECK GEAR POSITION.**

1) Lift-up or raise the vehicle and support with safety stand.

CAUTION:

On AWD models, raise all wheels off ground.

2) Start the engine.

3) Move select lever to "D", and drive vehicle.

4) Read data of gear position using Subaru Select Monitor.

- Gear position is indicated.

NOTE:

The speed difference between front and rear wheels may light the ABS warning light, but this indicates no malfunction. When AT control diagnosis is finished, perform the ABS memory clearance procedure of on-board diagnostics system. <Ref. to 4-4 [T6D2].>

CHECK : *Does the transmission gear correspond to the gear which is shown on display?*

YES : Go to step LINE PRESSURE DUTY SOLENOID. <Ref. to 3-2 [T9I0].>

NO : Check shift solenoid 1 and shift solenoid 2 signal circuit. <Ref. to 3-2 [T8J0].> and <Ref. to 3-2 [T8K0].>

I: CHECK LINE PRESSURE DUTY SOLENOID.**9I1 : CHECK OUTPUT SIGNAL EMITTED FROM TCM.**

1) Warm-up the transmission until ATF temperature is above 80°C (176°F).

NOTE:

If ambient temperature is below 0°C (32°F), drive the vehicle until the ATF reaches its operating temperature.

2) Stop the engine and turn ignition switch to ON (engine OFF).

3) Move select lever to "N".

4) Read data of line pressure duty solenoid using Subaru Select Monitor.

- Line pressure duty solenoid is indicated in "%".

CHECK : *Does the Subaru Select Monitor indicate 100% when the accelerator pedal is completely released?*

YES : Go to step 9I2.

NO : Go to step 9I4.

9I2 : CHECK OUTPUT SIGNAL EMITTED FROM TCM.

CHECK : *Does the Subaru Select Monitor indicate between 10 and 20% when the accelerator pedal is completely depressed?*

YES : Go to step 9I3.

NO : Go to step 9I4.

9I3 : CHECK OUTPUT SIGNAL EMITTED FROM TCM.

CHECK : *Does the Subaru Select Monitor change smoothly when the accelerator pedal is fully depressed and then fully released?*

YES : Go to step LOCK-UP DUTY SOLENOID. <Ref. to 3-2 [T9J0].>

NO : Go to step 9I4.

9I4 : CHECK THROTTLE POSITION SENSOR.

NOTE:

For the diagnostics procedure on throttle position sensor circuit, <Ref. to 3-2 [T9G0].>.

- CHECK** : *Is there any trouble in throttle position sensor circuit?*
- YES** : Repair or replace throttle position sensor circuit, <Ref. to 3-2 [T8E0].>.
- NO** : Go to step **9I5**.

9I5 : CHECK ENGINE SPEED SIGNAL.

NOTE:

For the diagnostics procedure on engine speed signal circuit, <Ref. to 3-2 [T9E0].>.

- CHECK** : *Is there any trouble in engine speed signal circuit?*
- YES** : Repair or replace engine speed signal circuit, <Ref. to 3-2 [T8C0].>.
- NO** : Go to step **9I6**.

9I6 : CHECK ATF TEMPERATURE SENSOR.

NOTE:

For the diagnostics procedure on ATF temperature sensor circuit, <Ref. to 3-2 [T9F1].>.

- CHECK** : *Is there any trouble in ATF temperature sensor circuit?*
- YES** : Repair or replace ATF temperature sensor circuit, <Ref. to 3-2 [T8D0].>.
- NO** : Go to step **9I7**.

9I7 : CHECK INHIBITOR SWITCH.

1) Turn ignition switch and Subaru Select Monitor to ON.

2) Read data of range switch using Subaru Select Monitor.

- Range switch is indicated in ON ⇔ OFF.

- CHECK** : *When each range is selected, does LED of the range switch on Subaru Select Monitor light up?*
- YES** : Go to step LOCK-UP DUTY SOLENOID. <Ref. to 3-2 [T9J0].>
- NO** : Check inhibitor switch circuit. <Ref. to 3-2 [T9T0].>

J: CHECK LOCK-UP DUTY SOLENOID.**9J1 : CHECK OUTPUT SIGNAL EMITTED FROM TCM.**

Read data of lock-up duty solenoid using Subaru Select Monitor.

- Lock-up duty solenoid is indicated in “%”.

- CHECK** : *Does the Subaru Select Monitor indicate 5%?*
- YES** : Go to step **9J2**.
- NO** : Go to step **9J3**.

9J2 : CHECK OUTPUT SIGNAL EMITTED FROM TCM.

Move select lever to “D” and slowly increase vehicle speed to 75 km/h (47 MPH).

NOTE:

The speed difference between front and rear wheels may light the ABS warning light, but this indicates no malfunction. When AT control diagnosis is finished, perform the ABS memory clearance procedure of on-board diagnostics system. <Ref. to 4-4 [T6D2].>

- CHECK** : *Does the Subaru Select Monitor indicate 95%?*
- YES** : Go to step TRANSFER DUTY SOLENOID. <Ref. to 3-2 [T9K0].>
- NO** : Go to step **9J3**.

9J3 : CHECK THROTTLE POSITION SENSOR.

NOTE:

For the diagnostics procedure on throttle position sensor circuit, <Ref. to 3-2 [T9G0].>.

- CHECK** : *Is there any trouble in throttle position sensor circuit?*
- YES** : Repair or replace throttle position sensor circuit, <Ref. to 3-2 [T8E0].>.
- NO** : Go to step **9J4**.

9J4 : CHECK VEHICLE SPEED SENSOR 1.

NOTE:

For the diagnostics procedure on vehicle speed sensor 1 circuit, <Ref. to 3-2 [T9C0].>.

- CHECK** : *Is there any trouble in vehicle speed sensor 1 circuit?*
- YES** : Repair or replace vehicle speed sensor 1 circuit, <Ref. to 3-2 [T8R0].>.
- NO** : Go to step **9J5**.

9J5 : CHECK VEHICLE SPEED SENSOR 2.

NOTE:

For the diagnostics procedure on vehicle speed sensor 2 circuit, <Ref. to 3-2 [T9D0].>.

- CHECK** : *Is there any trouble in vehicle speed sensor 2 circuit?*
- YES** : Repair or replace vehicle speed sensor 2 circuit, <Ref. to 3-2 [T8F0].>.
- NO** : Go to step **9J6**.

9J6 : CHECK ENGINE SPEED SIGNAL.

NOTE:

For the diagnostics procedure on engine speed signal circuit, <Ref. to 3-2 [T9E0].>.

- CHECK** : *Is there any trouble in engine speed signal circuit?*
- YES** : Repair or replace engine speed signal circuit, <Ref. to 3-2 [T8C0].>.
- NO** : Go to step **9J7**.

9J7 : CHECK INHIBITOR SWITCH.

Read data of range switch using Subaru Select Monitor.

- Range switch is indicated in ON ⇔ OFF.

- CHECK** : *When each range is selected, does LED of the range switch on Subaru Select Monitor light up?*
- YES** : Go to step TRANSFER DUTY SOLENOID. <Ref. to 3-2 [T9K0].>
- NO** : Check inhibitor switch circuit. <Ref. to 3-2 [T9T0].>

K: CHECK TRANSFER DUTY SOLENOID.**9K1 : CHECK OUTPUT SIGNAL EMITTED FROM TCM.**

- 1) Turn ignition switch to ON (engine OFF).
 - 2) Move select lever to "D".
 - 3) Read data of transfer duty solenoid using Subaru Select Monitor.
- Transfer duty solenoid is indicated in "%".

CHECK : *Does the duty solenoid change in response to the depress-release motion of the accelerator pedal?*

- YES** : Go to step **9K2**.
- NO** : Go to step **9K3**.

9K2 : CHECK OUTPUT SIGNAL EMITTED FROM TCM.

- 1) Turn ignition switch to OFF.
- 2) Set FWD mode.
- 3) Turn ignition switch to ON (engine OFF).

CHECK : *Does the Subaru Select Monitor indicate 95%?*

- YES** : Go to step THROTTLE POSITION SENSOR POWER SUPPLY. <Ref. to 3-2 [T9L0].>
- NO** : Go to step **9K3**.

9K3 : CHECK THROTTLE POSITION SENSOR.

NOTE:

For the diagnostics procedure on throttle position sensor circuit, <Ref. to 3-2 [T9G0].>.

- CHECK** : *Is there any trouble in throttle position sensor circuit?*
- YES** : Repair or replace throttle position sensor circuit, <Ref. to 3-2 [T8E0].>.
- NO** : Go to step **9K4**.

9K4 : CHECK VEHICLE SPEED SENSOR 1.

NOTE:

For the diagnostics procedure on vehicle speed sensor 1 circuit, <Ref. to 3-2 [T9C0].>.

- CHECK** : *Is there any trouble in vehicle speed sensor 1 circuit?*
- YES** : Repair or replace vehicle speed sensor 1 circuit, <Ref. to 3-2 [T8R0].>.
- NO** : Go to step **9K5**.

9K5 : CHECK VEHICLE SPEED SENSOR 2.

NOTE:

For the diagnostics procedure on vehicle speed sensor 2 circuit, <Ref. to 3-2 [T9D0].>.

- CHECK** : *Is there any trouble in vehicle speed sensor 2 circuit?*
- YES** : Repair or replace vehicle speed sensor 2 circuit, <Ref. to 3-2 [T8F0].>.
- NO** : Go to step **9K6**.

9K6 : CHECK ATF TEMPERATURE SENSOR.

NOTE:

For the diagnostics procedure on ATF temperature sensor circuit, <Ref. to 3-2 [T9F0].>.

- CHECK** : *Is there any trouble in ATF temperature sensor circuit?*
- YES** : Repair or replace ATF temperature sensor circuit, <Ref. to 3-2 [T8D0].>.
- NO** : Go to step **9K7**.

9K7 : CHECK INHIBITOR SWITCH.

Read data of range switch using Subaru Select Monitor.

- Range switch is indicated in ON ⇔ OFF.

- CHECK** : *When each range is selected, does LED of range switch on Subaru Select Monitor light up?*
- YES** : Go to step **9K8**.
- NO** : Check inhibitor switch circuit. <Ref. to 3-2 [T9T0].>

9K8 : CHECK ABS SIGNAL.

1) Start the engine, and turn Subaru Select Monitor switch to ON.

2) Read data of ABS signal using Subaru Select Monitor.

- ABS switch is indicated in ON ⇔ OFF.

- CHECK** : *Does the LED of ABS switch light up?*
- YES** : Check ABS signal circuit. <Ref. to 4-4 [T10Y0].> and <Ref. to 4-4 [T10Z0].>
- NO** : Go to step THROTTLE POSITION SENSOR POWER SUPPLY. <Ref. to 3-2 [T9L0].>

L: CHECK THROTTLE POSITION SENSOR POWER SUPPLY.**9L1 : CHECK THROTTLE POSITION SENSOR POWER SUPPLY.**

Read data of throttle position sensor power supply using Subaru Select Monitor.

- Throttle position sensor power supply voltage is indicated.

- CHECK** : *Is the value fixed between 4.8 and 5.3 V?*
- YES** : Go to step INTAKE MANIFOLD PRESSURE SIGNAL. <Ref. to 3-2 [T9M0].>
- NO** : Check throttle position sensor power supply circuit. <Ref. to 3-2 [T8E0].>

M: CHECK INTAKE MANIFOLD PRESSURE SIGNAL.**9M1 : CHECK INPUT SIGNAL FOR TCM.**

- 1) Start the engine.
- 2) Warm-up the engine until engine coolant temperature is above 80°C (176°F).

NOTE:

If ambient temperature is below 0°C (32°F), drive the vehicle until the ATF reaches its operating temperature.

- 3) Engine idling after warm-up.
- 4) Move select lever to "N".
- 5) Read data of intake manifold pressure signal using Subaru Select Monitor.
 - Display shows intake manifold pressure signal value sent from ECM.

CHECK : ***Does voltage change in response to the depress-release motion of the accelerator pedal?***

YES : Go to step **9M2**.

NO : Check intake manifold pressure signal circuit. <Ref. to 3-2 [T8I0].>

9M2 : CHECK ECM.

CHECK : ***Has trouble been eliminated after ECM replacement?***

YES : Replace ECM. <Ref. to 2-7 [W17A0].>

NO : Go to step **9M3**.

9M3 : CHECK TCM.**NOTE:**

Install former ECM.

CHECK : ***Has trouble been eliminated after TCM replacement?***

YES : Replace TCM. <Ref. to 3-2 [W23A0].>

NO : Go to step TORQUE CONVERTER TURBINE SPEED SENSOR. <Ref. to 3-2 [T9N0].>

N: CHECK TORQUE CONVERTER TURBINE SPEED SENSOR.**9N1 : CHECK TORQUE CONVERTER TURBINE SPEED SENSOR.**

- 1) Lift-up or raise the vehicle and support with safety stand.

CAUTION:

On AWD models, raise all wheels off ground.

- 2) Read data of torque converter turbine speed sensor using Subaru Select Monitor.

- Compare speedometer with Subaru Select Monitor indications.
- Vehicle speed is indicated in "MPH" or "km/h".

NOTE:

The speed difference between front and rear wheels may light the ABS warning light, but this indicates no malfunction. When AT control diagnosis is finished, perform the ABS memory clearance procedure of on-board diagnostics system. <Ref. to 4-4 [T6D2].>

CHECK : ***Does the speedometer indication increase as the Subaru Select Monitor data increases?***

YES : Go to step 2-4 BRAKE DUTY SOLENOID. <Ref. to 3-2 [T9O0].>

NO : Check torque converter turbine speed sensor circuit. <Ref. to 3-2 [T8G0].>

O: CHECK 2-4 BRAKE DUTY SOLENOID.**901 : CHECK OUTPUT SIGNAL EMITTED FROM TCM.**

1) Warm-up the transmission until ATF temperature is above 80°C (176°F).

NOTE:

If ambient temperature is below 0°C (32°F), drive the vehicle until the ATF reaches its operating temperature.

2) Stop the engine and turn ignition switch to ON (engine OFF).

3) Move select lever to "N".

4) Read data of 2-4 brake duty solenoid using Subaru Select Monitor.

- 2-4 brake duty solenoid is indicated in "%".

CHECK : *Does the Subaru Select Monitor indicate 100% when the accelerator pedal is completely released?*

YES : Go to step 902.

NO : Go to step 904.

902 : CHECK OUTPUT SIGNAL EMITTED FROM TCM.

CHECK : *Does the Subaru Select Monitor indicate between 10 and 20% when the accelerator pedal is completely depressed?*

YES : Go to step 903.

NO : Go to step 904.

903 : CHECK OUTPUT SIGNAL EMITTED FROM TCM.

CHECK : *Does the Subaru Select Monitor change smoothly when the accelerator pedal is fully depressed and then fully released?*

YES : Go to step FWD SWITCH. <Ref. to 3-2 [T9P0].>

NO : Go to step 904.

904 : CHECK THROTTLE POSITION SENSOR.**NOTE:**

For the diagnostics procedure on throttle position sensor circuit, <Ref. to 3-2 [T9G0].>

CHECK : *Is there any trouble in throttle position sensor circuit?*

YES : Repair or replace throttle position sensor circuit, <Ref. to 3-2 [T8E0].>

NO : Go to step 905.

905 : CHECK ENGINE SPEED SIGNAL.**NOTE:**

For the diagnostics procedure on engine speed signal circuit, <Ref. to 3-2 [T9E0].>

CHECK : *Is there any trouble in engine speed signal circuit?*

YES : Repair or replace engine speed signal circuit, <Ref. to 3-2 [T8C0].>

NO : Go to step 906.

906 : CHECK ATF TEMPERATURE SENSOR.**NOTE:**

For the diagnostics procedure on ATF temperature sensor circuit, <Ref. to 3-2 [T9F0].>

CHECK : *Is there any trouble in ATF temperature sensor circuit?*

YES : Repair or replace ATF temperature sensor circuit, <Ref. to 3-2 [T8D0].>

NO : Go to step 907.

907 : CHECK INHIBITOR SWITCH.

1) Turn ignition switch and Subaru Select Monitor to ON.

2) Read data of range switch using Subaru Select Monitor.

- Range switch is indicated in ON ⇔ OFF.

CHECK : *When each range is selected, does LED of the range switch on Subaru Select Monitor light up?*

YES : Go to step FWD SWITCH. <Ref. to 3-2 [T9P0].>

NO : Check inhibitor switch circuit. <Ref. to 3-2 [T9T0].>

P: CHECK FWD SWITCH.

DIAGNOSIS:

- LED does not come on even if FWD switch is ON.
- FWD switch circuit is open or short.

WIRING DIAGRAM:

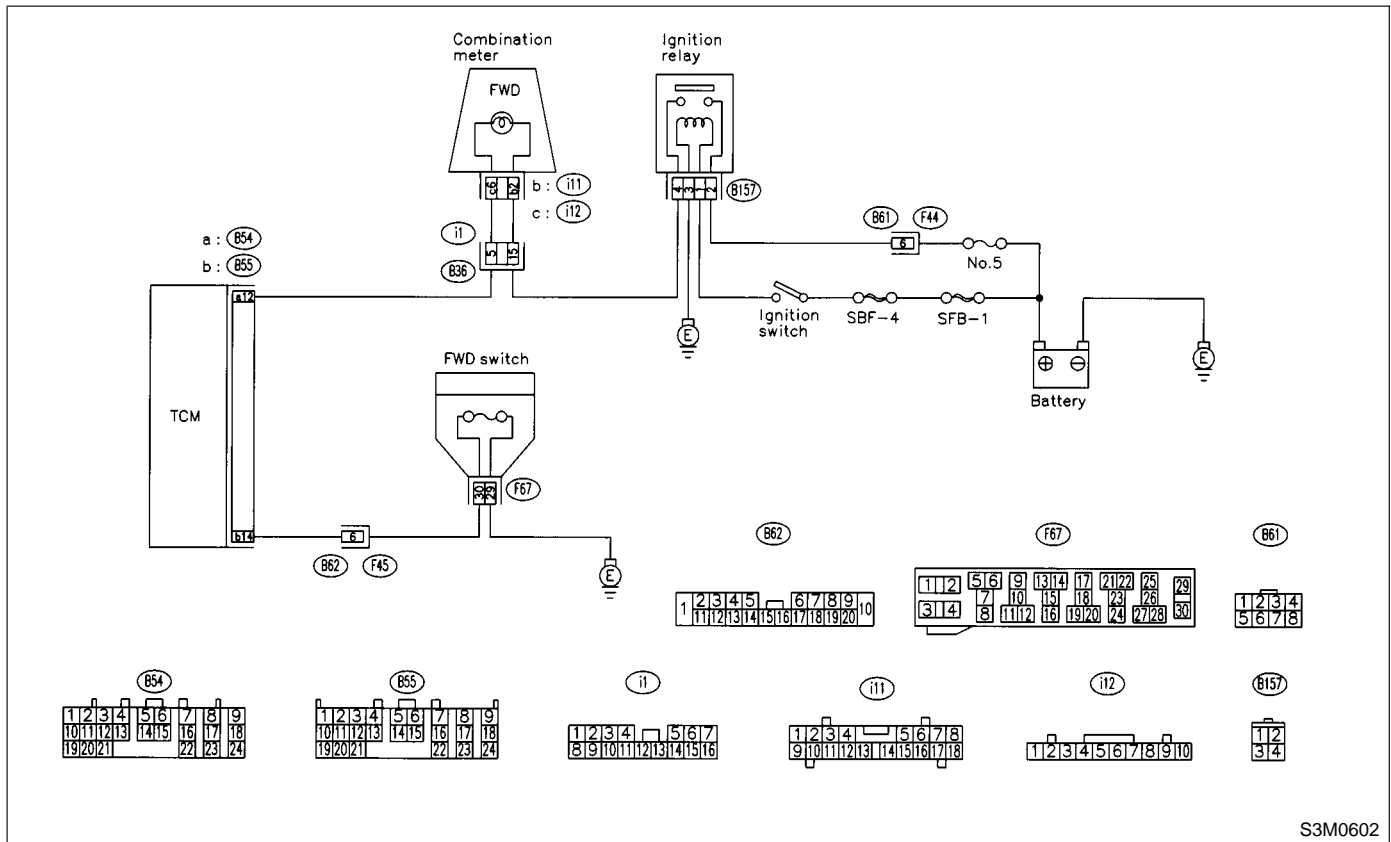

S3M0602

9P1 : CHECK FWD SWITCH.

- CHECK** : When fuse is inserted to FWD switch, does LED light up?
- YES** : Go to step BRAKE SWITCH. <Ref. to 3-2 [T9Q0].>
- NO** : Go to step 9P2.

9P2 : CHECK HARNESS CONNECTOR BETWEEN TCM AND FWD SWITCH.

- 1) Turn ignition switch to OFF.
- 2) Disconnect connector from FWD switch.
- 3) Measure resistance of harness between TCM and FWD switch connector.

Connector & terminal

(B55) No. 14 — (F67) No. 30:

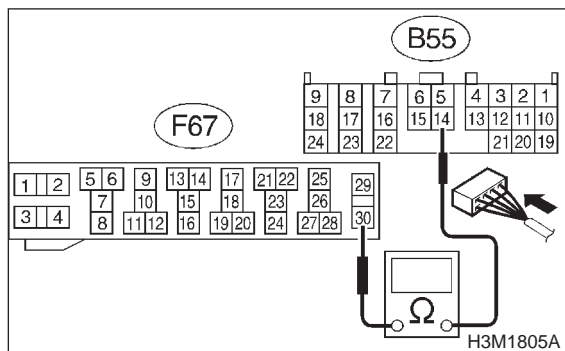

- CHECK** : Is the resistance less than 1 Ω?
- YES** : Go to step 9P3.
- NO** : Repair open circuit in harness between TCM and FWD switch connector.

9P3 : CHECK HARNESS CONNECTOR BETWEEN TCM AND FWD SWITCH.

Measure resistance of harness connector between TCM and body to make sure that circuit does not short.

Connector & terminal

(B55) No. 14 — Chassis ground:

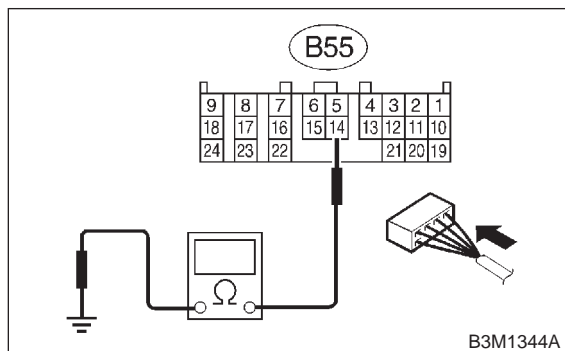

- CHECK** : Is the resistance more than 1 MΩ?
- YES** : Go to step 9P4.
- NO** : Repair short circuit in harness connector between TCM and chassis ground.

9P4 : CHECK INPUT SIGNAL FOR TCM.

- 1) Turn ignition switch to OFF.
- 2) Connect connector to FWD switch.
- 3) Turn ignition switch to ON.
- 4) Measure signal voltage for TCM while installing the fuse to FWD switch connector.

Connector & terminal

(B55) No. 14 (+) — Chassis ground (-):

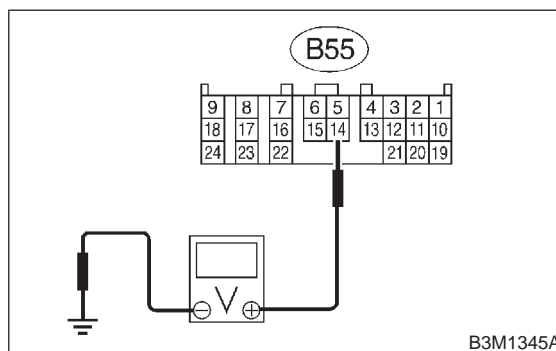

- CHECK** : Is the voltage less than 1 V in FWD switch while installing?
- YES** : Go to step 9P5.
- NO** : Go to step 9P11.

9P5 : CHECK INPUT SIGNAL FOR TCM.

Measure signal voltage for TCM while removing the fuse from FWD switch connector.

Connector & terminal

(B55) No. 14 (+) — Chassis ground (-):

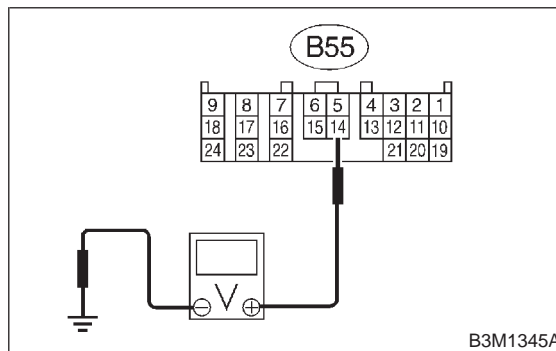

- CHECK** : Is the voltage between 6 and 9.1 V in FWD switch while removing?
- YES** : Go to step 9P6.
- NO** : Replace TCM. <Ref. to 3-2 [W23A0].>

9P6 : CHECK FWD INDICATOR LIGHT.

- 1) Turn ignition switch to OFF.
- 2) Remove combination meter.
- 3) Remove FWD indicator light bulb from combination meter.

- CHECK** : *Is FWD indicator light bulb OK?*
YES : Go to step **9P7**.
NO : Replace FWD indicator light bulb.

9P7 : CHECK HARNESS CONNECTOR BETWEEN TCM AND COMBINATION METER.

- 1) Turn ignition switch to OFF.
- 2) Disconnect connector from combination meter.
- 3) Measure resistance of harness between TCM and combination meter connector.

Connector & terminal
(B54) No. 12 — (i12) No. 6:

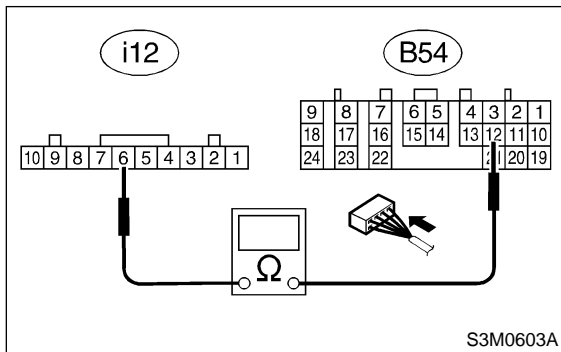

- CHECK** : *Is the resistance less than 1 Ω?*
YES : Go to step **9P8**.
NO : Repair open circuit in harness between TCM and combination meter and poor contact in coupling connector.

9P8 : CHECK HARNESS CONNECTOR BETWEEN TCM AND COMBINATION METER.

Measure resistance of harness connector between TCM and chassis ground to make sure that circuit does not short.

Connector & terminal
(B54) No. 12 — Chassis ground:

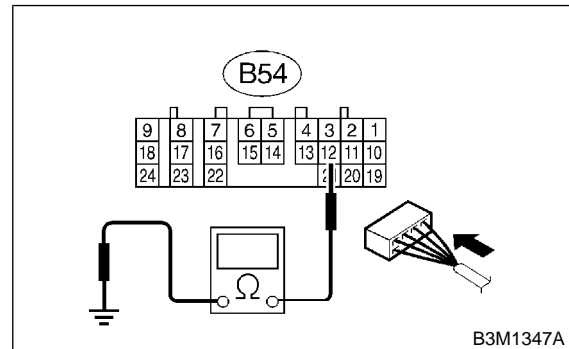

- CHECK** : *Is the resistance more than 1 MΩ?*
YES : Go to step **9P9**.
NO : Repair short circuit in harness between TCM and combination meter connector.

9P9 : CHECK OUTPUT SIGNAL EMITTED FROM TCM.

- 1) Turn ignition switch to OFF.
- 2) Connect connector to combination meter.
- 3) Turn ignition switch to ON.
- 4) Measure signal voltage for TCM while installing and removing the fuse to FWD switch connector.

Connector & terminal
(B54) No. 12 — Chassis ground:

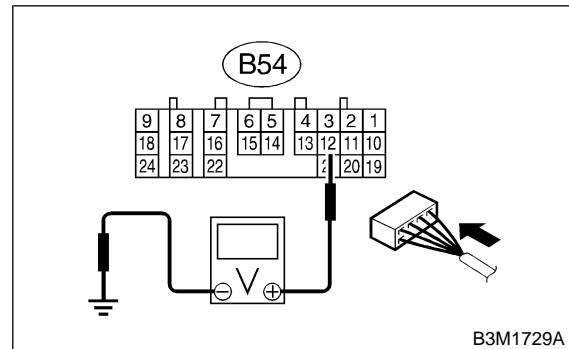

- CHECK** : *Is the voltage less than 1 V in FWD switch while installing?*
YES : Go to step **9P10**.
NO : Go to step **9P11**.

9P10 : CHECK OUTPUT SIGNAL EMITTED FROM TCM.

Measure signal voltage for TCM while removing the fuse from FWD switch connector.

Connector & terminal

(B54) No. 12 — Chassis ground:

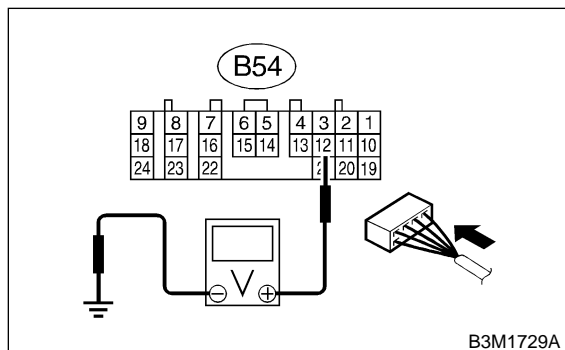

CHECK : *Is the voltage more than 9 V in FWD switch while removing?*

YES : Go to step **9P11**.

NO : Replace TCM. <Ref. to 3-2 [W23A0].>

9P11 : CHECK POOR CONTACT.

CHECK : *Is there poor contact in FWD switch circuit?*

YES : Repair poor contact.

NO : Replace TCM. <Ref. to 3-2 [W23A0].>

Q: CHECK BRAKE SWITCH.**9Q1 : CHECK BRAKE SWITCH.**

CHECK : *When the brake pedal is depressed, does LED light up?*

YES : Go to step ABS SWITCH. <Ref. to 3-2 [T9R0].>

NO : Check brake switch circuit. <Ref. to 2-7 [T10AW0].>

R: CHECK ABS SWITCH.**9R1 : CHECK ABS SWITCH.**

CHECK : *Does the LED of ABS switch light up?*

YES : Check ABS switch circuit. <Ref. to 4-4 [T10Y0].> and <Ref. to 4-4 [T10Z0].>

NO : Go to step CRUISE CONTROL SWITCH. <Ref. to 3-2 [T9S0].>

S: CHECK CRUISE CONTROL SWITCH.**9S1 : CHECK CRUISE CONTROL SWITCH.**

CHECK : *When cruise control is set, does LED light up?*

YES : Go to step INHIBITOR SWITCH. <Ref. to 3-2 [T9T0].>

NO : Check cruise control. <Ref. to 6-2 [T2A0].>

T: CHECK INHIBITOR SWITCH.

DIAGNOSIS:

Input signal circuit of inhibitor switch is open or shorted.

TROUBLE SYMPTOM:

- Shift characteristics are erroneous.
- Engine brake is not effected when select lever is in "3" range.
- Engine brake is not effected when select lever is in "2" range.
- Engine brake is not effected when select lever is in "1" range.

WIRING DIAGRAM:

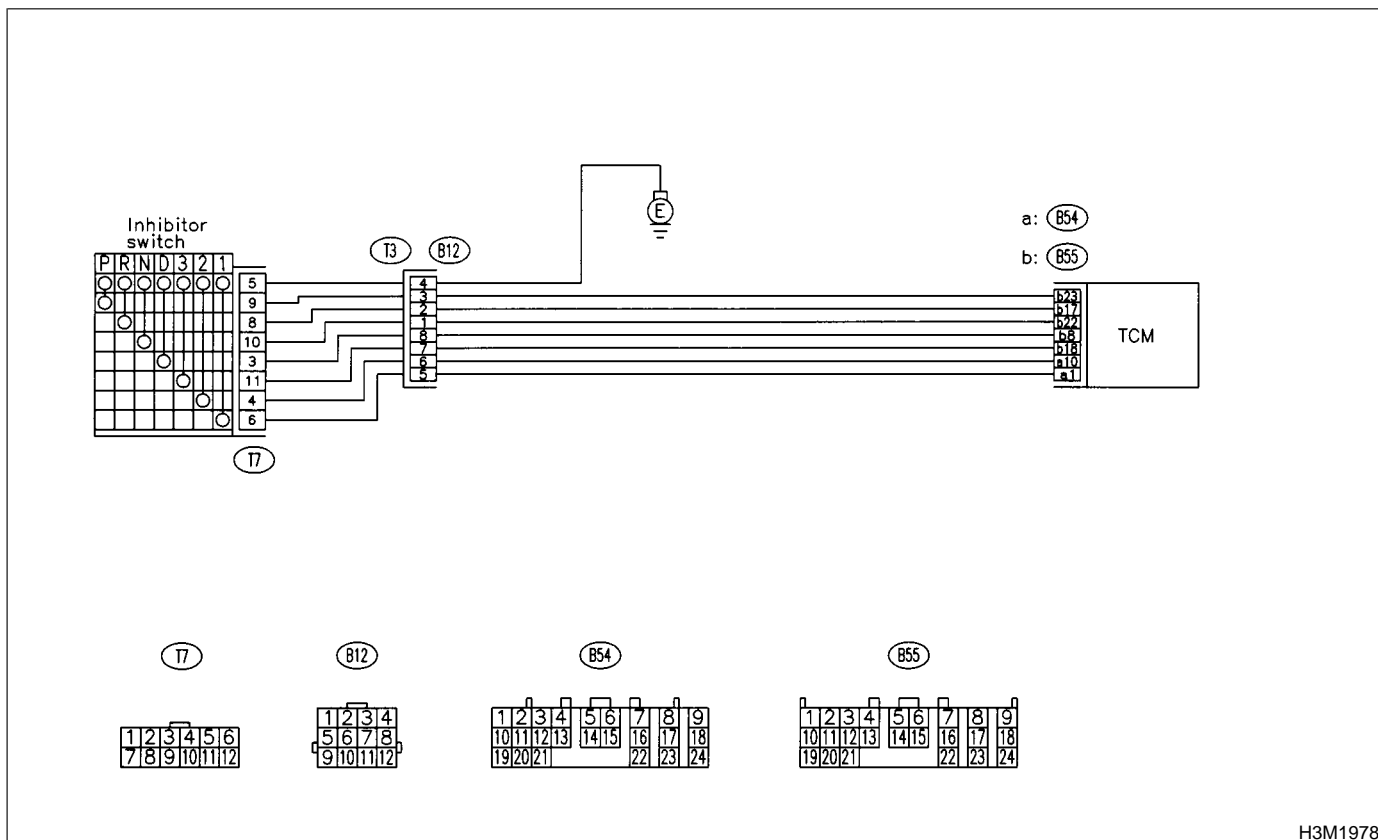

H3M1978

9T1 : CHECK "P" RANGE SWITCH.

- CHECK** : When "P" range is selected, does LED light up?
- YES** : Go to step 9T2.
- NO** : Go to step 9T15.

9T2 : CHECK "P" RANGE SWITCH.

- CHECK** : When the "R" range is selected, does "P" range LED light up?
- YES** : Go to step 9T20.
- NO** : Go to step 9T3.

9T3 : CHECK "R" RANGE SWITCH.

- CHECK** : When the "R" range is selected, does LED light up?
- YES** : Go to step 9T4.
- NO** : Go to step 9T22.

9T4 : CHECK "R" RANGE SWITCH.

- CHECK** : When the "N" range is selected, does "R" range LED light up?
- YES** : Go to step 9T26.
- NO** : Go to step 9T5.

9T5 : CHECK "N" RANGE SWITCH.

CHECK : *When the "N" range is selected, does LED light up?*

YES : Go to step 9T6.

NO : Go to step 9T28.

9T6 : CHECK "N" RANGE SWITCH.

CHECK : *When the "D" range is selected, does "N" range LED light up?*

YES : Go to step 9T32.

NO : Go to step 9T7.

9T7 : CHECK "D" RANGE SWITCH.

CHECK : *When the "D" range is selected, does LED light up?*

YES : Go to step 9T8.

NO : Go to step 9T34.

9T8 : CHECK "D" RANGE SWITCH.

CHECK : *When the "3" range is selected, does "D" range LED light up?*

YES : Go to step 9T38.

NO : Go to step 9T9.

9T9 : CHECK "3" RANGE SWITCH.

CHECK : *When the "3" range is selected, does LED light up?*

YES : Go to step 9T10.

NO : Go to step 9T40.

9T10 : CHECK "3" RANGE SWITCH.

CHECK : *When the "2" range is selected, does "3" range LED light up?*

YES : Go to step 9T11.

NO : Go to step 9T44.

9T11 : CHECK "2" RANGE SWITCH.

CHECK : *When the "2" range is selected, does LED light up?*

YES : Go to step 9T12.

NO : Go to step 9T46.

9T12 : CHECK "2" RANGE SWITCH.

CHECK : *When the "1" range is selected, does "2" range LED light up?*

YES : Go to step 9T13.

NO : Go to step 9T50.

9T13 : CHECK "1" RANGE SWITCH.

CHECK : *When the "1" range is selected, does LED light up?*

YES : Go to step 9T14.

NO : Go to step 9T52.

9T14 : CHECK "1" RANGE SWITCH.

CHECK : *When the "P" range is selected, does "1" range LED light UP?*

YES : Go to step 9T56.

NO : Go to step SHIFT SOLENOID 1. <Ref. to 3-2 [T9U0].>

9T15 : CHECK HARNESS CONNECTOR BETWEEN INHIBITOR SWITCH AND CHASSIS GROUND.

- 1) Turn ignition switch to OFF.
- 2) Disconnect connector from inhibitor switch.
- 3) Measure resistance of harness between inhibitor switch and chassis ground.

Connector & terminal

(B12) No. 4 — Chassis ground:

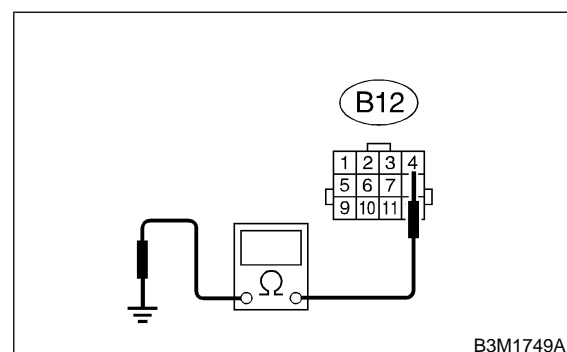

CHECK : *Is the resistance less than 1 Ω?*

YES : Go to step 9T16.

NO : Repair open circuit in harness between inhibitor switch harness.

9T16 : CHECK HARNESS CONNECTOR BETWEEN TCM AND INHIBITOR SWITCH.

- 1) Turn ignition switch to OFF.
- 2) Disconnect connector from inhibitor switch.
- 3) Measure resistance of harness between TCM and inhibitor switch connector.

Connector & terminal
(B55) No. 23 — (B12) No. 3:

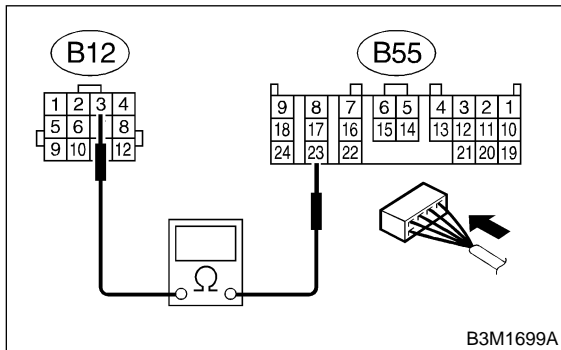

- CHECK** : Is the resistance less than 1 Ω?
- YES** : Go to step 9T17.
- NO** : Repair open circuit in harness between TCM and inhibitor switch connector, and poor contact in coupling connector.

9T17 : CHECK INHIBITOR SWITCH.

Measure resistance between inhibitor switch connector receptacle's terminals.

Connector & terminal
(T3) No. 4 — No. 3:

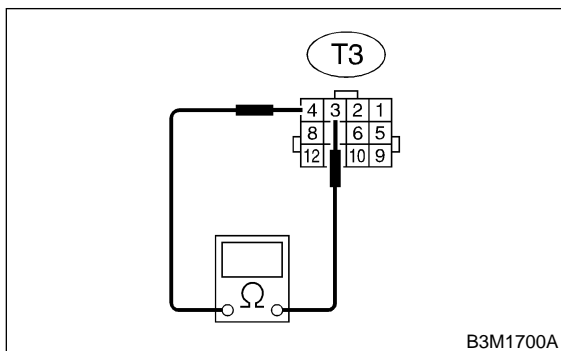

- CHECK** : Is the resistance less than 1 Ω in "P" range?
- YES** : Go to step 9T18.
- NO** : Adjust inhibitor switch and select cable <Ref. to 3-2 [W200].> and <Ref. to 3-3 [W2A0].>

9T18 : CHECK INPUT SIGNAL FOR TCM.

- 1) Turn ignition switch to OFF.
- 2) Connect connector to inhibitor switch.
- 3) Turn ignition switch to ON.
- 4) Measure voltage between TCM and chassis ground.

Connector & terminal
(B55) No. 23 (+) — Chassis ground (-):

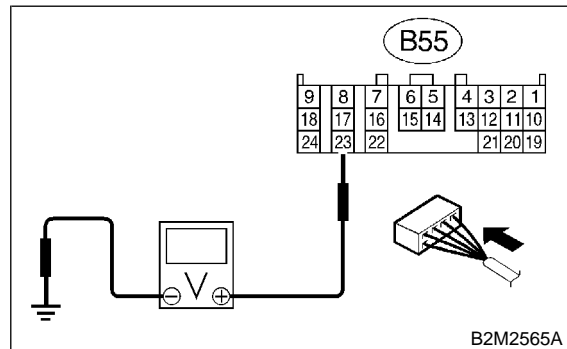

- CHECK** : Is the voltage less than 1 V in "P" range?
- YES** : Go to step 9T19.
- NO** : Go to step 9T58.

9T19 : CHECK INPUT SIGNAL FOR TCM.

Measure voltage between TCM and chassis ground.

Connector & terminal
(B55) No. 23 (+) — Chassis ground (-):

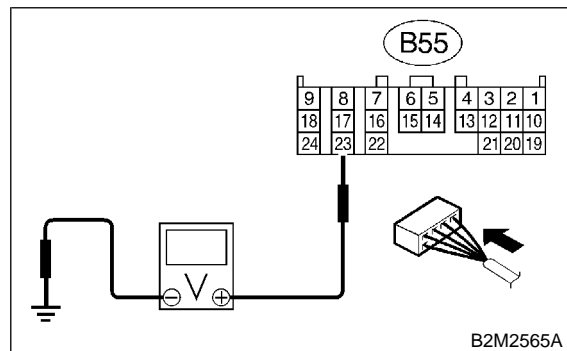

- CHECK** : Is the voltage more than 8 V in other ranges (except "N" range)?
- YES** : Go to step 9T58.
- NO** : Replace TCM. <Ref. to 3-2 [W23A0].>

9T20 : CHECK HARNESS CONNECTOR BETWEEN TCM AND INHIBITOR SWITCH.

- 1) Turn ignition switch to OFF.
- 2) Disconnect connectors from inhibitor switch.
- 3) Measure resistance of harness between TCM and chassis ground.

Connector & terminal
(B55) No. 23 — Chassis ground:

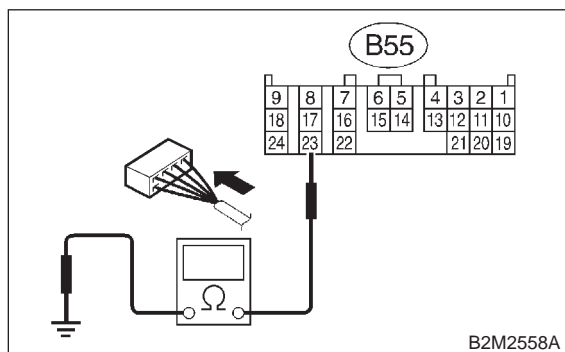

- CHECK** : Is the resistance more than 1 MΩ?
- YES** : Go to step 9T21.
- NO** : Repair ground short circuit in “P” range circuit.

9T21 : CHECK INHIBITOR SWITCH.

Measure resistance between inhibitor switch connector receptacle’s terminals.

Connector & terminal
(T3) No. 4 — No. 3:

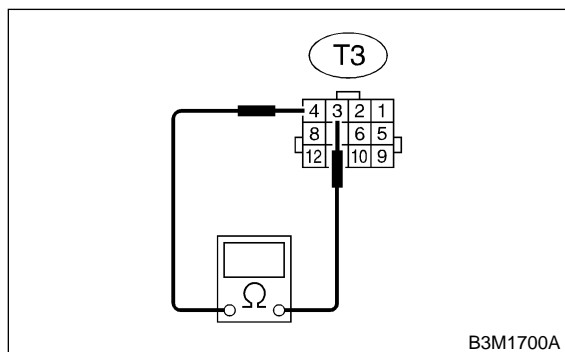

- CHECK** : Is the resistance more than 1 MΩ in other ranges (except “N” range)?
- YES** : Replace TCM. <Ref. to 3-2 [W23A0].>
- NO** : Adjust inhibitor switch and select cable <Ref. to 3-2 [W200].> and <Ref. to 3-3 [W2A0].>.

9T22 : CHECK HARNESS CONNECTOR BETWEEN TCM AND INHIBITOR SWITCH.

- 1) Turn ignition switch to OFF.
- 2) Disconnect connector from inhibitor switch.
- 3) Measure resistance of harness between TCM and inhibitor switch connector.

Connector & terminal
(B55) No. 17 — (B12) No. 2:

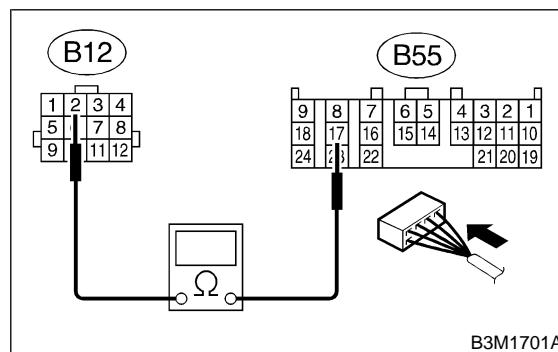

- CHECK** : Is the resistance less than 1 Ω?
- YES** : Go to step 9T23.
- NO** : Repair open circuit in harness between TCM and inhibitor switch connector, and poor contact in coupling connector.

9T23 : CHECK INHIBITOR SWITCH.

Measure resistance between inhibitor switch connector receptacle’s terminals.

Connector & terminal
(T3) No. 2 — No. 4:

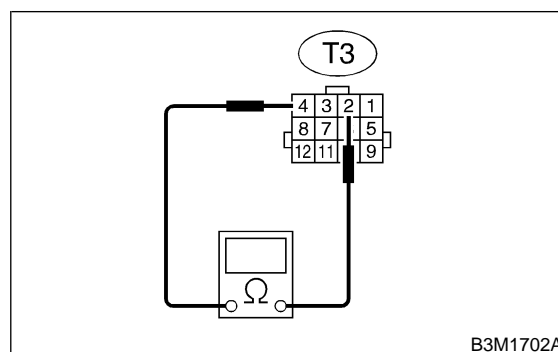

- CHECK** : Is the resistance less than 1 Ω in “R” range?
- YES** : Go to step 9T24.
- NO** : Adjust inhibitor switch and select cable <Ref. to 3-2 [W200].> and <Ref. to 3-3 [W2A0].>.

9T24 : CHECK INPUT SIGNAL FOR TCM.

- 1) Turn ignition switch to OFF.
- 2) Connect connector to inhibitor switch.
- 3) Turn ignition switch to ON.
- 4) Measure voltage between TCM and chassis ground.

Connector & terminal
(B55) No. 17 (+) — Chassis ground (-):

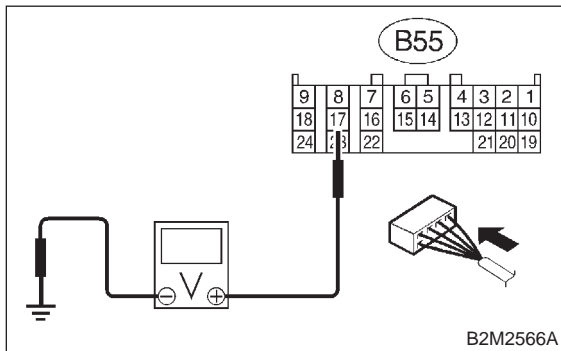

- CHECK** : Is the voltage less than 1 V in “R” range?
- YES** : Go to step 9T25.
- NO** : Go to step 9T58.

9T25 : CHECK INPUT SIGNAL FOR TCM.

Measure voltage between TCM and chassis ground.

Connector & terminal
(B55) No. 17 (+) — Chassis ground (-):

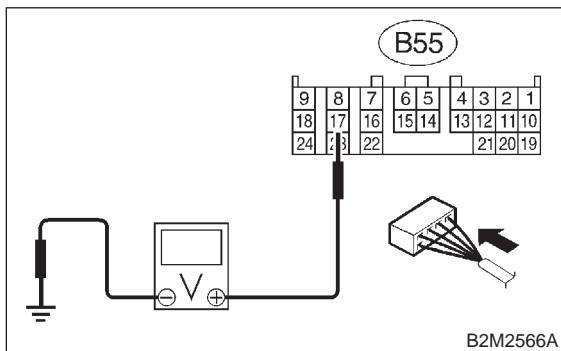

- CHECK** : Is the voltage more than 9.5 V in other ranges?
- YES** : Go to step 9T58.
- NO** : Replace TCM. <Ref. to 3-2 [W23A0].>

9T26 : CHECK HARNESS CONNECTOR BETWEEN TCM AND INHIBITOR SWITCH.

- 1) Turn ignition switch to OFF.
- 2) Disconnect connector from inhibitor switch.
- 3) Measure resistance of harness between TCM and chassis ground.

Connector & terminal
(B55) No. 17 — Chassis ground:

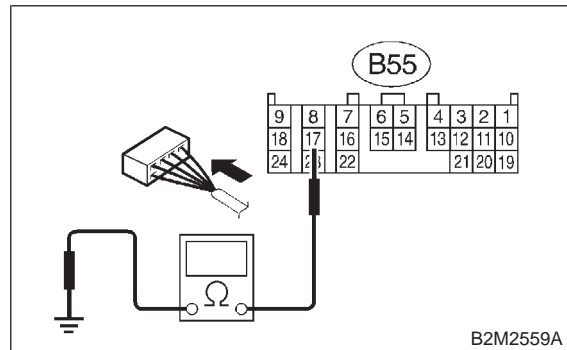

- CHECK** : Is the resistance more than 1 MΩ?
- YES** : Go to step 9T27.
- NO** : Repair ground short circuit in “R” range circuit.

9T27 : CHECK INHIBITOR SWITCH.

Measure resistance between inhibitor switch connector receptacle’s terminals.

Connector & terminal
(T3) No. 2 — No. 4:

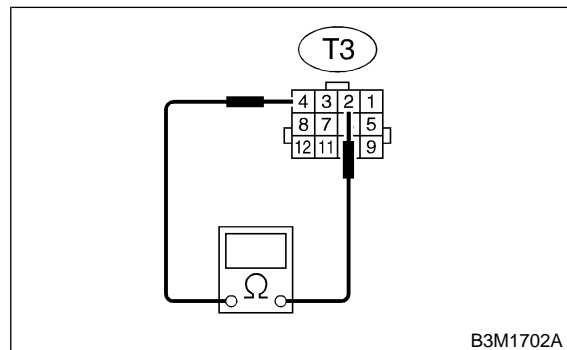

- CHECK** : Is the resistance more than 1 MΩ in other ranges?
- YES** : Replace TCM. <Ref. to 3-2 [W23A0].>
- NO** : Adjust inhibitor switch and select cable <Ref. to 3-2 [W200].> and <Ref. to 3-3 [W2A0].>.

9T28 : CHECK HARNESS CONNECTOR BETWEEN TCM AND INHIBITOR SWITCH.

- 1) Turn ignition switch to OFF.
- 2) Disconnect connector from inhibitor switch.
- 3) Measure resistance of harness between TCM and inhibitor switch connector.

Connector & terminal
(B55) No. 22 (+) — (B12) No. 1:

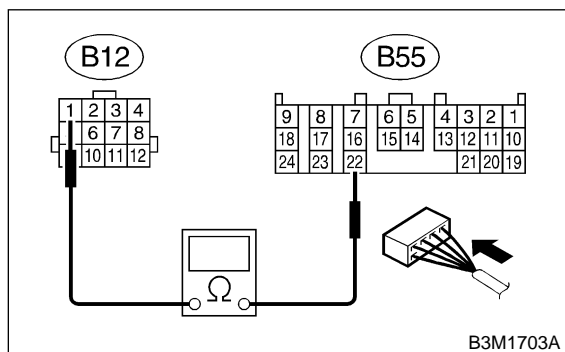

- CHECK** : Is the resistance less than 1 Ω?
- YES** : Go to step 9T29.
- NO** : Repair open circuit in harness between TCM and inhibitor switch connector, and poor contact in coupling connector.

9T29 : CHECK INHIBITOR SWITCH.

Measure resistance between inhibitor switch connector receptacle's terminals.

Connector & terminal
(T3) No. 4 — No. 1:

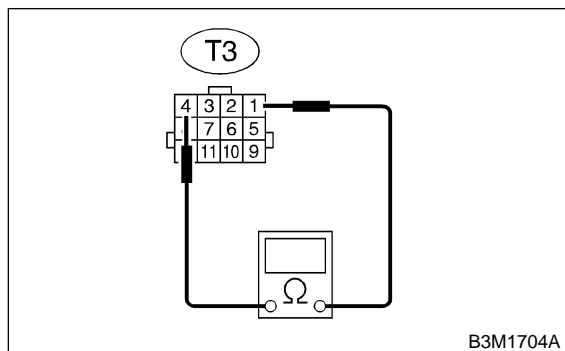

- CHECK** : Is the resistance less than 1 Ω in "N" range?
- YES** : Go to step 9T30.
- NO** : Adjust inhibitor switch and select cable <Ref. to 3-2 [W200].> and <Ref. to 3-3 [W2A0].>.

9T30 : CHECK INPUT SIGNAL FOR TCM.

- 1) Turn ignition switch to OFF.
- 2) Connect connector to inhibitor switch.
- 3) Turn ignition switch to ON.
- 4) Measure voltage between TCM and chassis ground.

Connector & terminal
(B55) No. 22 (+) — Chassis ground (-):

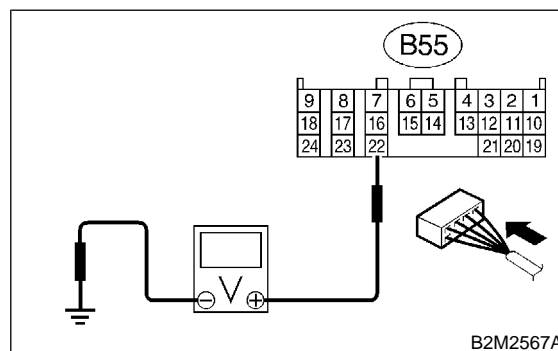

- CHECK** : Is the voltage less than 1 V in "N" range?
- YES** : Go to step 9T31.
- NO** : Go to step 9T58.

9T31 : CHECK INPUT SIGNAL FOR TCM.

Measure voltage between TCM and chassis ground.

Connector & terminal
(B55) No. 22 (+) — Chassis ground (-):

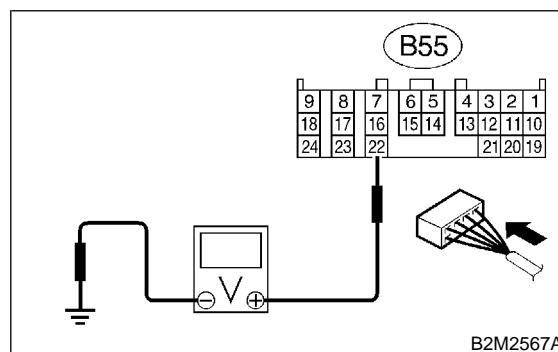

- CHECK** : Is the voltage more than 8 V in other ranges (except "P" range)?
- YES** : Go to step 9T58.
- NO** : Replace TCM. <Ref. to 3-2 [W23A0].>

9T32 : CHECK HARNESS CONNECTOR BETWEEN TCM AND INHIBITOR SWITCH.

- 1) Turn ignition switch to OFF.
- 2) Disconnect connectors from inhibitor switch.
- 3) Measure resistance of harness between TCM and chassis ground.

Connector & terminal

(B55) No. 22 — Chassis ground:

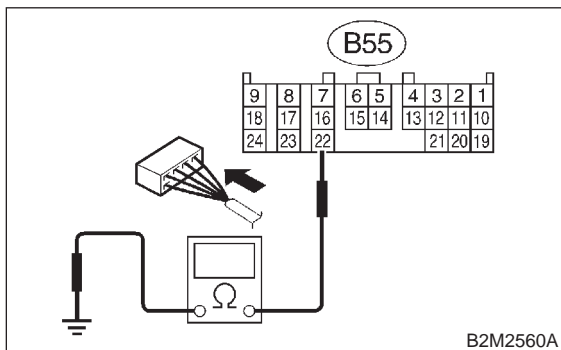

- CHECK** : Is the resistance more than 1 MΩ?
- YES** : Go to step 9T33.
- NO** : Repair ground short circuit in “N” range circuit.

9T33 : CHECK INHIBITOR SWITCH.

Measure resistance between inhibitor switch connector receptacle’s terminals.

Connector & terminal

(T3) No. 1 — No. 4:

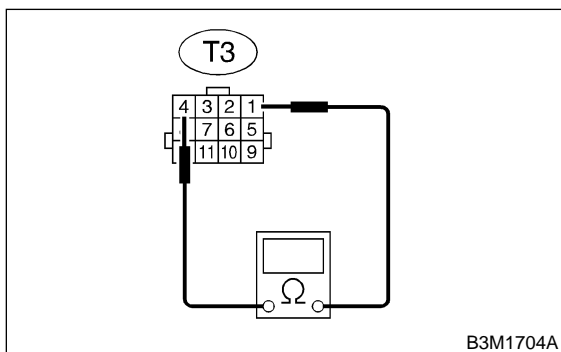

- CHECK** : Is the resistance more than 1 MΩ in other ranges (except “P” range)?
- YES** : Replace TCM. <Ref. to 3-2 [W23A0].>
- NO** : Adjust inhibitor switch and select cable <Ref. to 3-2 [W200].> and <Ref. to 3-3 [W2A0].>.

9T34 : CHECK HARNESS CONNECTOR BETWEEN TCM AND INHIBITOR SWITCH.

- 1) Turn ignition switch to OFF.
- 2) Disconnect connectors from inhibitor switch.
- 3) Measure resistance of harness between TCM and inhibitor switch connector.

Connector & terminal

(B55) No. 8 — (B12) No. 8:

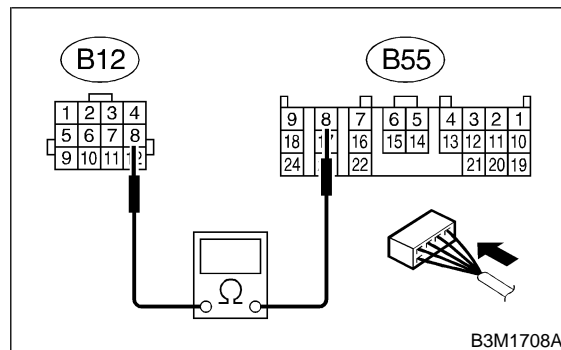

- CHECK** : Is the resistance less than 1 Ω?
- YES** : Go to step 9T35.
- NO** : Repair open circuit in harness between TCM and inhibitor switch connector, and poor contact in coupling connector.

9T35 : CHECK INHIBITOR SWITCH.

Measure resistance between inhibitor switch connector receptacle’s terminals.

Connector & terminal

(T3) No. 4 — No. 8:

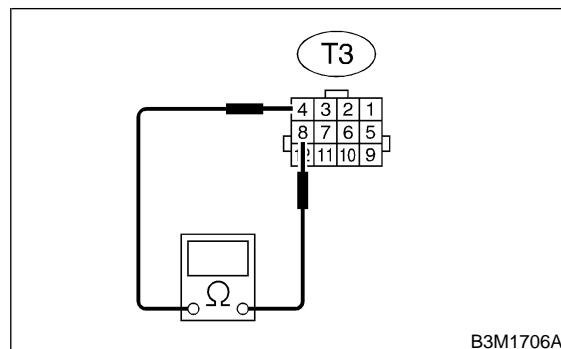

- CHECK** : Is the resistance less than 1 Ω in “D” range?
- YES** : Go to step 9T36.
- NO** : Adjust inhibitor switch and select cable <Ref. to 3-2 [W200].> and <Ref. to 3-3 [W2A0].>.

9T36 : CHECK INPUT SIGNAL FOR TCM.

- 1) Turn ignition switch to OFF.
- 2) Connect connector to inhibitor switch.
- 3) Turn ignition switch to ON.
- 4) Measure voltage between TCM and chassis ground.

Connector & terminal
(B55) No. 8 (+) — Chassis ground (-):

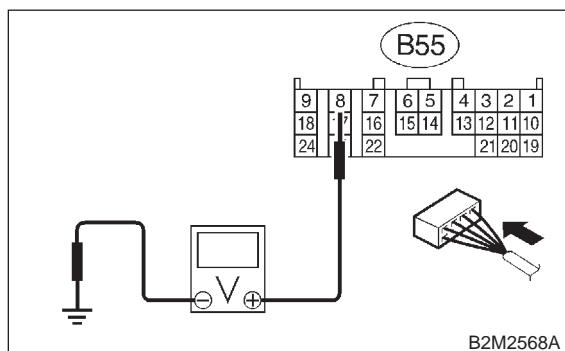

- CHECK** : Is the voltage less than 1 V in “D” range?
- YES** : Go to step 9T37.
- NO** : Go to step 9T58.

9T37 : CHECK INPUT SIGNAL FOR TCM.

Measure voltage between TCM and chassis ground.

Connector & terminal
(B55) No. 8 (+) — Chassis ground (-):

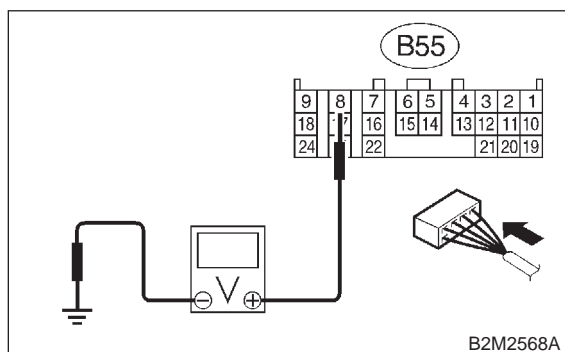

- CHECK** : Is the voltage more than 9.5 V in other ranges?
- YES** : Go to step 9T58.
- NO** : Replace TCM. <Ref. to 3-2 [W23A0].>

9T38 : CHECK HARNESS CONNECTOR BETWEEN TCM AND INHIBITOR SWITCH.

- 1) Turn ignition switch to OFF.
- 2) Disconnect connectors from inhibitor switch.
- 3) Measure resistance of harness between TCM and chassis ground.

Connector & terminal
(B55) No. 8 — Chassis ground:

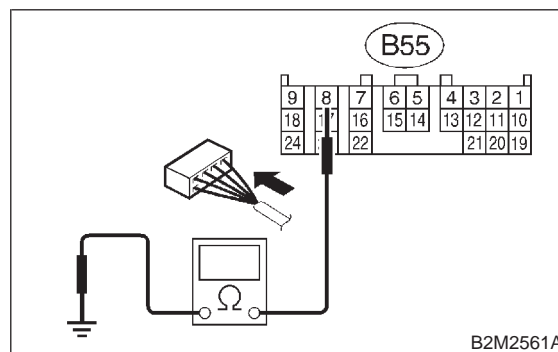

- CHECK** : Is the resistance more than 1 MΩ?
- YES** : Go to step 9T39.
- NO** : Repair ground short circuit in “D” range circuit.

9T39 : CHECK INHIBITOR SWITCH.

Measure resistance between inhibitor switch connector receptacle’s terminals.

Connector & terminal
(T3) No. 4 — No. 8:

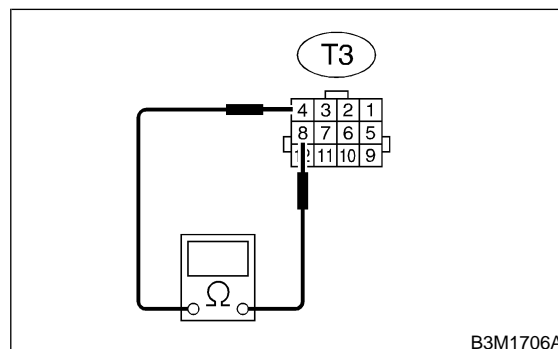

- CHECK** : Is the resistance more than 1 MΩ in other ranges?
- YES** : Replace TCM. <Ref. to 3-2 [W23A0].>
- NO** : Adjust inhibitor switch and select cable <Ref. to 3-2 [W200].> and <Ref. to 3-3 [W2A0].>

9T40 : CHECK HARNESS CONNECTOR BETWEEN TCM AND INHIBITOR SWITCH.

- 1) Turn ignition switch to OFF.
- 2) Disconnect connector from inhibitor switch.
- 3) Measure resistance of harness between TCM and inhibitor switch connector.

Connector & terminal
(B55) No. 18 — (B12) No. 7:

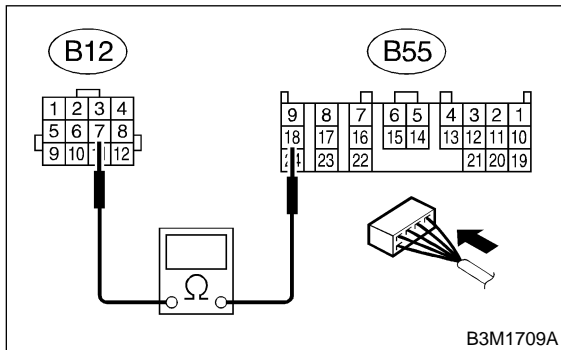

- CHECK** : Is the resistance less than 1 Ω?
- YES** : Go to step 9T41.
- NO** : Repair open circuit in harness between TCM and inhibitor switch connector, and poor contact in coupling connector.

9T41 : CHECK INHIBITOR SWITCH.

Measure resistance between inhibitor switch connector receptacle's terminals.

Connector & terminal
(T3) No. 4 — No. 7:

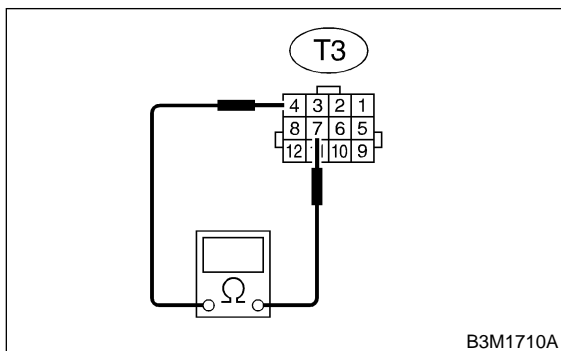

- CHECK** : Is the resistance less than 1 Ω in "3" range?
- YES** : Go to step 9T42.
- NO** : Adjust inhibitor switch and select cable <Ref. to 3-2 [W200].> and <Ref. to 3-2 [W2A0].>

9T42 : CHECK INPUT SIGNAL FOR TCM.

- 1) Turn ignition switch to OFF.
- 2) Connect connector to inhibitor switch.
- 3) Turn ignition switch to ON.
- 4) Measure voltage between TCM and chassis ground.

Connector & terminal
(B55) No. 18 (+) — Chassis ground (-):

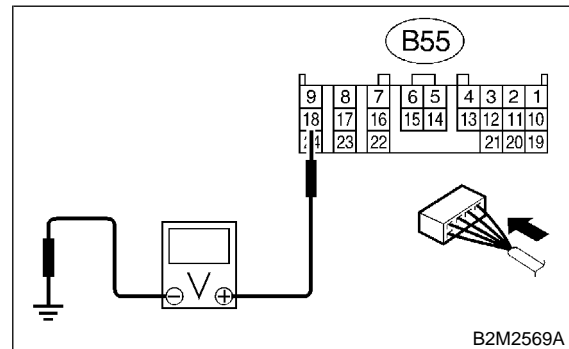

- CHECK** : Is the voltage less than 1 V in "3" range?
- YES** : Go to step 9T43.
- NO** : Go to step 9T58.

9T43 : CHECK INPUT SIGNAL FOR TCM.

Measure voltage between TCM and chassis ground.

Connector & terminal
(B55) No. 18 (+) — Chassis ground (-):

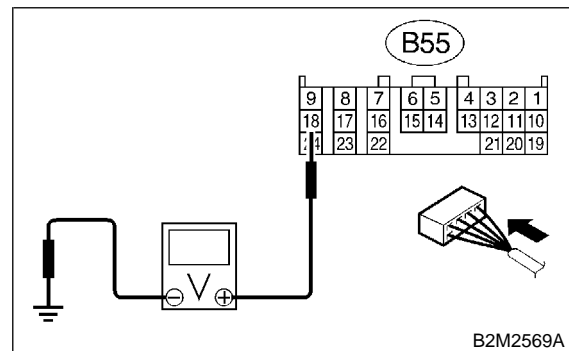

- CHECK** : Is the voltage more than 9.5 V in other ranges?
- YES** : Go to step 9T58.
- NO** : Replace TCM. <Ref. to 3-2 [W23A0].>

9T44 : CHECK HARNESS CONNECTOR BETWEEN TCM AND INHIBITOR SWITCH.

- 1) Turn ignition switch to OFF.
- 2) Disconnect connector from inhibitor switch.
- 3) Measure resistance of harness between TCM and chassis ground.

Connector & terminal
(B55) No. 18 — Chassis ground:

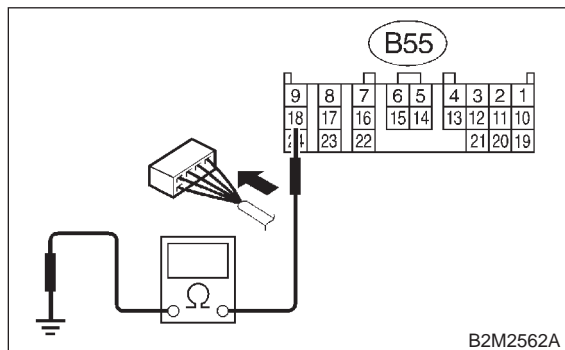

- CHECK** : Is the resistance more than 1 MΩ?
YES : Go to step 9T45.
NO : Repair ground short circuit in “3” range circuit.

9T45 : CHECK INHIBITOR SWITCH.

Measure resistance between inhibitor switch connector receptacle’s terminals.

Connector & terminal
(T3) No. 4 — No. 7:

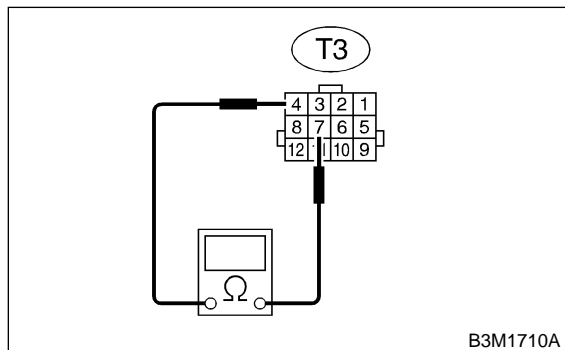

- CHECK** : Is the resistance more than 1 MΩ in other ranges?
YES : Replace TCM. <Ref. to 3-2 [W23A0].>
NO : Adjust inhibitor switch and select cable <Ref. to 3-2 [W200].> and <Ref. to 3-3 [W2A0].>.

9T46 : CHECK HARNESS CONNECTOR BETWEEN TCM AND INHIBITOR SWITCH.

- 1) Turn ignition switch to OFF.
- 2) Disconnect connector from inhibitor switch.
- 3) Measure resistance of harness between TCM and inhibitor switch connector.

Connector & terminal
(B54) No. 10 — (B12) No. 6:

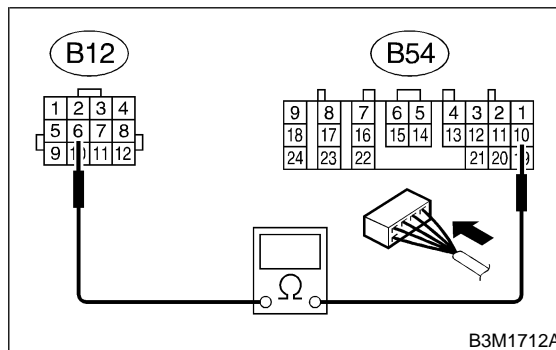

- CHECK** : Is the resistance less than 1 Ω?
YES : Go to step 9T47.
NO : Repair open circuit in harness between TCM and inhibitor switch connector, and poor contact in coupling connector.

9T47 : CHECK INHIBITOR SWITCH.

Measure resistance between inhibitor switch connector receptacle’s terminals.

Connector & terminal
(T3) No. 6 — No. 4:

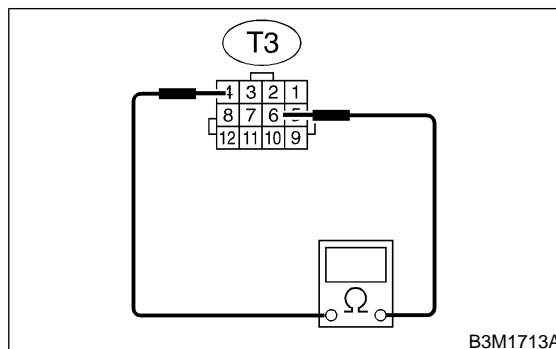

- CHECK** : Is the resistance less than 1 Ω in “2” range?
YES : Go to step 9T48.
NO : Adjust inhibitor switch and select cable <Ref. to 3-2 [W200].> and <Ref. to 3-3 [W2A0].>.

9T48 : CHECK INPUT SIGNAL FOR TCM.

- 1) Turn ignition switch to OFF.
- 2) Connect connector to inhibitor switch.
- 3) Turn ignition switch to ON.
- 4) Measure voltage between TCM and chassis ground.

Connector & terminal

(B54) No. 10 (+) — Chassis ground (-):

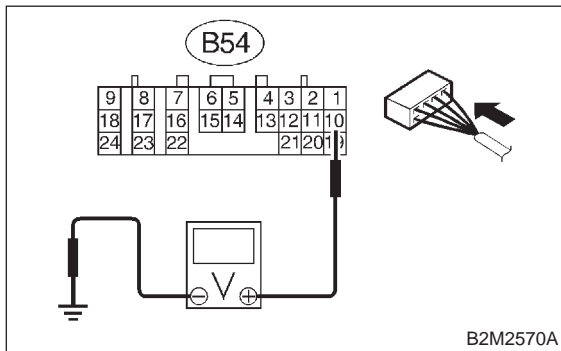

- CHECK** : Is the voltage less than 1 V in “2” range?
- YES** : Go to step 9T49.
- NO** : Go to step 9T58.

9T49 : CHECK INPUT SIGNAL FOR TCM.

Measure voltage between TCM and chassis ground.

Connector & terminal

(B54) No. 10 (+) — Chassis ground (-):

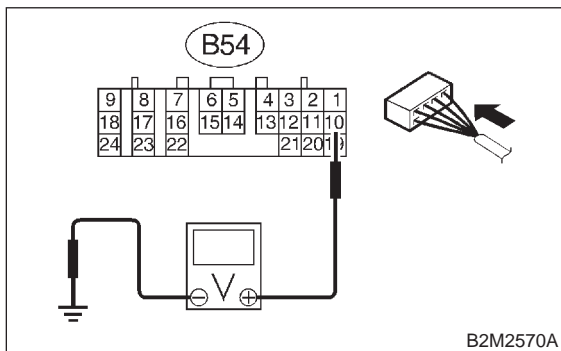

- CHECK** : Is the voltage more than 9.5 V in other ranges?
- YES** : Go to step 9T58.
- NO** : Replace TCM. <Ref. to 3-2 [W23A0].>

9T50 : CHECK HARNESS CONNECTOR BETWEEN TCM AND INHIBITOR SWITCH.

- 1) Turn ignition switch to OFF.
- 2) Disconnect connector from inhibitor switch.
- 3) Measure resistance of harness between TCM and chassis ground.

Connector & terminal

(B54) No. 10 — Chassis ground:

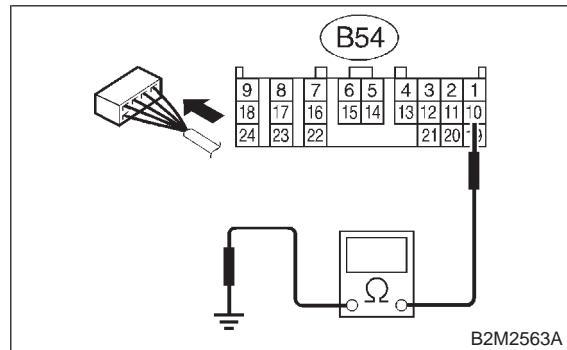

- CHECK** : Is the resistance more than 1 MΩ?
- YES** : Go to step 9T51.
- NO** : Repair ground short circuit in “2” range circuit.

9T51 : CHECK INHIBITOR SWITCH.

Measure resistance between inhibitor switch connector receptacle’s terminals.

Connector & terminal

(T3) No. 6 — No. 4:

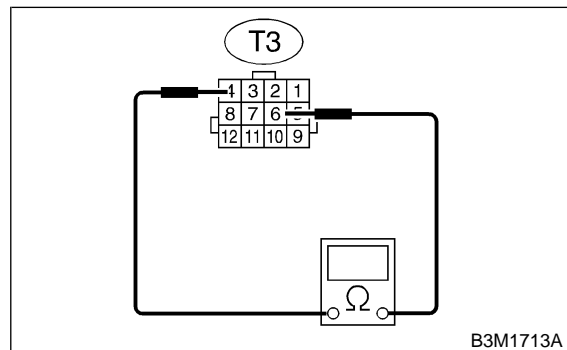

- CHECK** : Is the resistance more than 1 MΩ in other ranges?
- YES** : Replace TCM. <Ref. to 3-2 [W23A0].>
- NO** : Adjust inhibitor switch and select cable <Ref. to 3-2 [W200].> and <Ref. to 3-3 [W2A0].>.

9T52 : CHECK HARNESS CONNECTOR BETWEEN TCM AND INHIBITOR SWITCH.

- 1) Turn ignition switch to OFF.
- 2) Disconnect connector from inhibitor switch.
- 3) Measure resistance of harness between TCM and inhibitor switch connector.

Connector & terminal
(B54) No. 1 — (B12) No. 5:

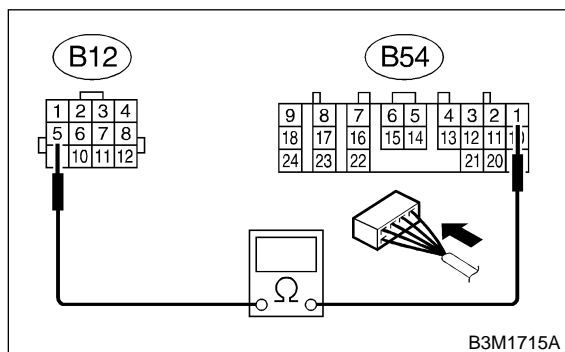

- CHECK** : Is the resistance less than 1 Ω?
- YES** : Go to step 9T53.
- NO** : Repair open circuit in harness between TCM and inhibitor switch connector, and poor contact in coupling connector.

9T53 : CHECK INHIBITOR SWITCH.

Measure resistance between inhibitor switch connector receptacle's terminals.

Connector & terminal
(T3) No. 5 — No. 4:

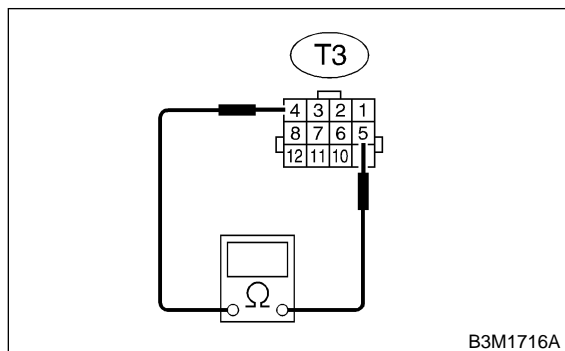

- CHECK** : Is the resistance less than 1 Ω in "1" range?
- YES** : Go to step 9T54.
- NO** : Adjust inhibitor switch and select cable <Ref. to 3-2 [W200].> and <Ref. to 3-3 [W2A0].>.

9T54 : CHECK INPUT SIGNAL FOR TCM.

- 1) Turn ignition switch to OFF.
- 2) Connect connector to inhibitor switch.
- 3) Turn ignition switch to ON.
- 4) Measure voltage between TCM and chassis ground.

Connector & terminal
(B54) No. 1 (+) — Chassis ground (-):

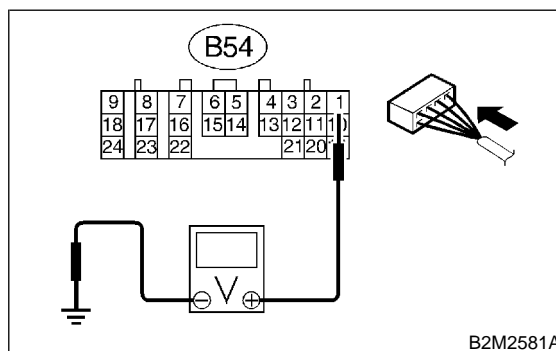

- CHECK** : Is the voltage less than 1 V in "1" range?
- YES** : Go to step 9T55.
- NO** : Go to step 9T58.

9T55 : CHECK INPUT SIGNAL FOR TCM.

Measure voltage between TCM and chassis ground.

Connector & terminal
(B54) No. 1 (+) — Chassis ground (-):

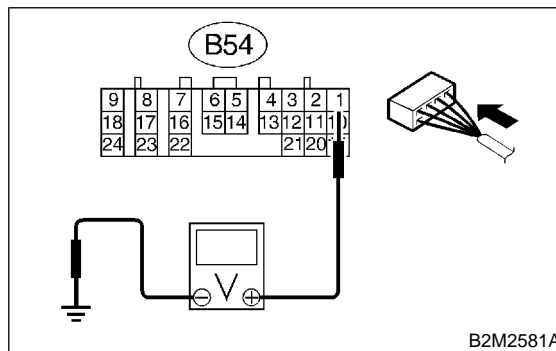

- CHECK** : Is the voltage more than 9.5 V in other ranges?
- YES** : Go to step 9T58.
- NO** : Replace TCM. <Ref. to 3-2 [W23A0].>

9T56 : CHECK HARNESS CONNECTOR BETWEEN TCM AND INHIBITOR SWITCH.

- 1) Turn ignition switch to OFF.
- 2) Disconnect connector from inhibitor switch.
- 3) Measure resistance of harness between TCM and chassis ground.

Connector & terminal

(B54) No. 1 — Chassis ground:

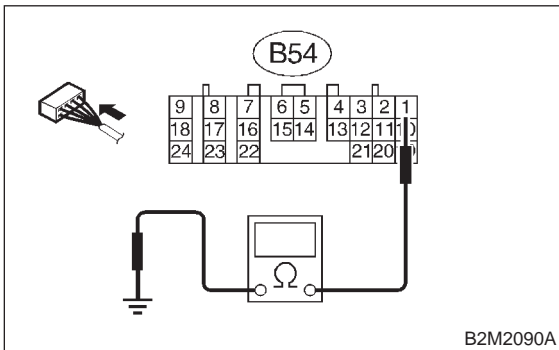

B2M2090A

- CHECK** : *Is the resistance more than 1 MΩ?*
- YES** : Go to step 9T57.
- NO** : Repair ground short circuit in “1” range circuit.

9T57 : CHECK INHIBITOR SWITCH.

Measure resistance between inhibitor switch connector receptacle’s terminals.

Connector & terminal

(T3) No. 5 — No. 4:

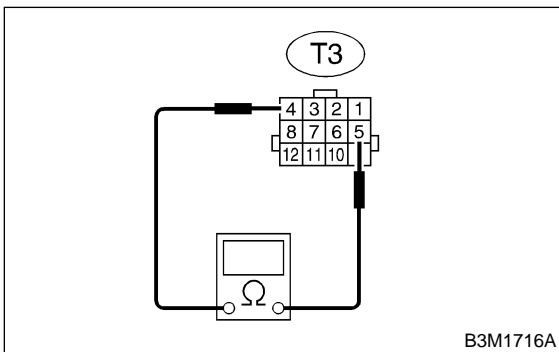

B3M1716A

- CHECK** : *Is the resistance more than 1 MΩ in other ranges?*
- YES** : Replace TCM. <Ref. to 3-2 [W23A0].>
- NO** : Adjust inhibitor switch and select cable <Ref. to 3-2 [W200].> and <Ref. to 3-3 [W2A0].>.

9T58 : CHECK POOR CONTACT.

- CHECK** : *Is there poor contact in inhibitor switch circuit?*
- YES** : Repair poor contact.
- NO** : Replace TCM. <Ref. to 3-2 [W23A0].>

U: CHECK SHIFT SOLENOID 1.

9U1 : CHECK SHIFT SOLENOID 1.

- CHECK** : *Does the LED of shift solenoid 1 light up?*
- YES** : Go to step SHIFT SOLENOID 2. <Ref. to 3-2 [T9V0].>
- NO** : Check shift solenoid 1 circuit. <Ref. to 3-2 [T8J0].>

V: CHECK SHIFT SOLENOID 2.

9V1 : CHECK SHIFT SOLENOID 2.

- CHECK** : *Does the LED of shift solenoid 2 light up?*
- YES** : Go to step TORQUE CONTROL 1 SIGNAL. <Ref. to 3-2 [T9W0].>
- NO** : Check shift solenoid 2 circuit. <Ref. to 3-2 [T8K0].>

W: CHECK TORQUE CONTROL 1 SIGNAL.

9W1 : CHECK TORQUE CONTROL 1 SIGNAL.

Turn ignition switch to ON (engine ON).

- CHECK** : *Does the LED of torque control 1 signal light up?*
- YES** : Go to step TORQUE CONTROL 2 SIGNAL. <Ref. to 3-2 [T9X0].>
- NO** : Check torque control 1 signal circuit. <Ref. to 3-2 [T8H0].>

X: CHECK TORQUE CONTROL 2 SIGNAL.

9X1 : CHECK TORQUE CONTROL 2 SIGNAL.

Turn ignition switch to ON (engine ON).

- CHECK** : *Does the LED of torque control 2 signal illuminate?*
- YES** : Go to step 2-4 BRAKE TIMING SOLENOID. <Ref. to 3-2 [T9Y0].>
- NO** : Check torque control 2 signal circuit. <Ref. to 3-2 [T8H0].>

Y: CHECK 2-4 BRAKE TIMING SOLENOID.

9Y1 : CHECK 2-4 BRAKE TIMING SOLENOID.

Turn ignition switch to ON, and select 1 range.

- CHECK** : *Does the LED of 2-4 brake timing solenoid illuminate?*
- YES** : Go to step LOW CLUTCH TIMING SOLENOID. <Ref. to 3-2 [T9Z0].>
- NO** : Check 2-4 brake timing solenoid circuit. <Ref. to 3-2 [T8M0].>

Z: CHECK LOW CLUTCH TIMING SOLENOID.

9Z1 : CHECK LOW CLUTCH TIMING SOLENOID.

Turn ignition switch to ON, and select 2 range.

- CHECK** : *Does the LED of low clutch timing solenoid illuminate?*
- YES** : Go to step DIAGNOSIS LIGHT. <Ref. to 3-2 [T9AA0].>
- NO** : Check low clutch timing solenoid circuit. <Ref. to 3-2 [T8L0].>

AA: CHECK DIAGNOSIS LIGHT.

9AA1 : CHECK DIAGNOSIS LIGHT.

Turn ignition switch to ON (engine OFF).

- CHECK** : *Does diagnosis light illuminate?*
- YES** : Go to step FWD LIGHT. <Ref. to 3-2 [T9AB0].>
- NO** : Check diagnosis light circuit.

AB: CHECK FWD LIGHT.

9AB1 : CHECK FWD LIGHT.

- CHECK** : *Does the LED of FWD light illuminate?*
- YES** : Check FWD switch circuit. <Ref. to 3-2 [T9P0].>
- NO** : Go to step General Diagnostic Table. <Ref. to 3-2 [T1000].>