

6) Install snap pin to range select lever.

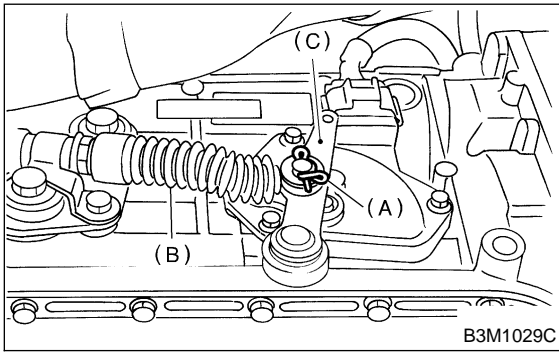

- (A) Snap pin
- (B) Select cable
- (C) Range select lever

7) Install front exhaust pipe. <Ref. to 2-9 [W1B0].>
8) Connect inhibitor switch connector.

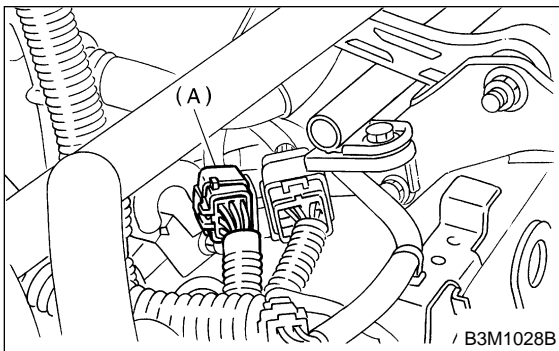

- (A) Inhibitor switch

9) Install air cleaner case and duct. <Ref. to 2-7 [W1A0].>

3. Sensor (in transmission)

A: INSPECTION

1) Remove air cleaner case and duct. <Ref. to 2-7 [W1A0].>

2) Disconnect transmission connector.

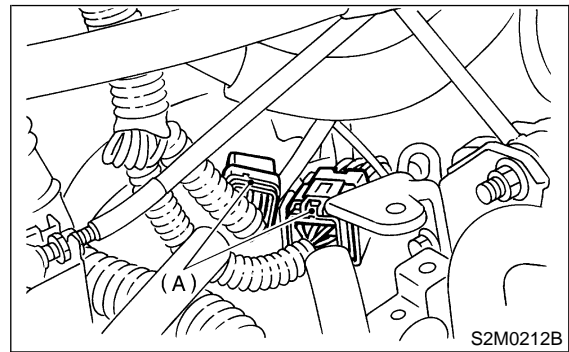

- (A) Transmission harness connector

3) Check each sensor, solenoid and ground system for short circuits.

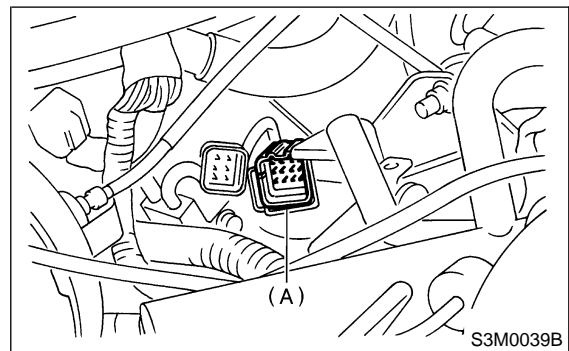

- (A) Transmission connector

3. Sensor (in transmission)

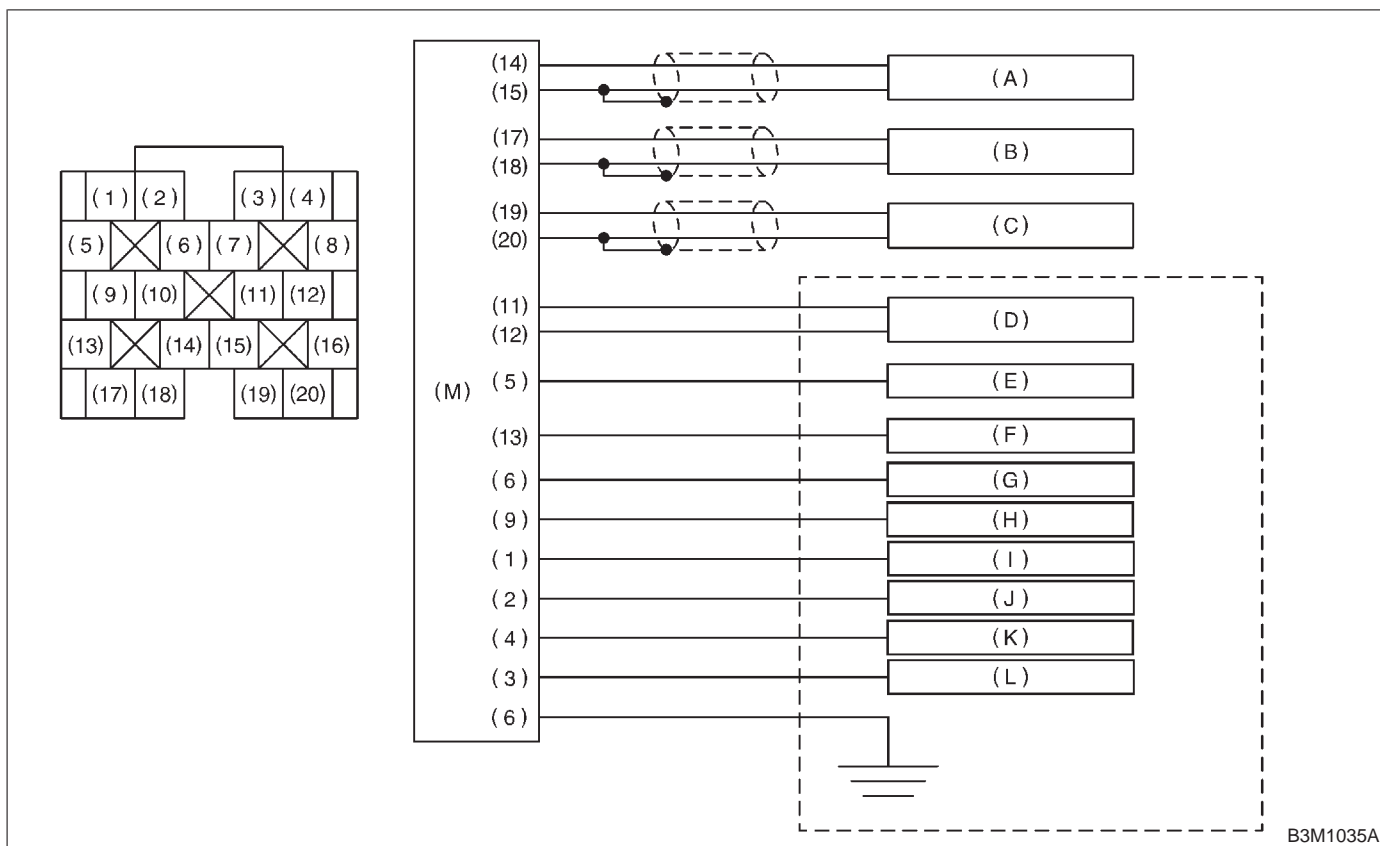

- (A) Torque converter turbine speed sensor
- (B) Vehicle speed sensor 2 (Front)
- (C) Vehicle speed sensor 1 (Rear)
- (D) ATF temperature sensor

- (E) Line pressure duty solenoid
- (F) Lock-up duty solenoid
- (G) Transfer duty solenoid
- (H) 2-4 brake duty solenoid
- (I) Shift solenoid 1

- (J) Shift solenoid 2
- (K) 2-4 brake timing solenoid
- (L) Low clutch timing solenoid
- (M) Transmission connector

1. EVALUATION

NOTE:

If part is faulty, its resistance value will be different from the standard value indicated.

Part name	Terminal	Resistance (Ω)
Vehicle speed sensor 1	17 — 18	450 — 650
Vehicle speed sensor 2	19 — 20	450 — 650
ATF temperature sensor	11 — 12	2,100 — 2,900/ 20°C (68°F) 275 — 375/ 80°C (176°F)
Torque converter turbine speed sensor	14 — 15	450 — 650
Shift solenoid 1	1 — 16	10 — 16
Shift solenoid 2	2 — 16	10 — 16
Line pressure duty solenoid	5 — 16	2.0 — 4.5
Lock-up duty solenoid	13 — 16	10 — 17
2-4 brake duty solenoid	9 — 16	2.0 — 4.5
Low clutch timing solenoid	3 — 16	10 — 16
2-4 brake timing solenoid	4 — 16	10 — 16
Transfer duty solenoid	6 — 16	10 — 17

4. Shift Solenoid, Duty Solenoid and Valve

A: REMOVAL

- 1) Clean transmission exterior.
- 2) Drain ATF completely.

NOTE:

Tighten ATF drain plug after draining ATF.

Tightening torque:

25±2 N·m (2.5±0.2 kg·m, 18.1±1.4 ft·lb)

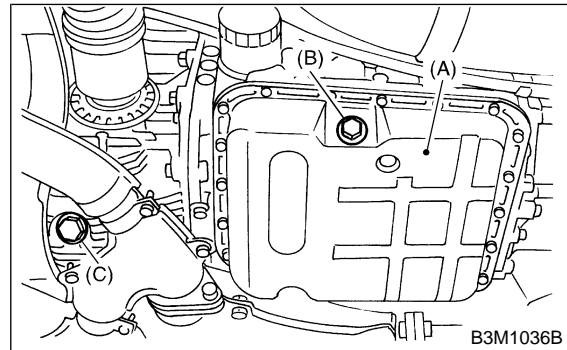

- (A) Oil pan
- (B) Drain plug
- (C) Differential oil drain plug

- 3) Remove oil pan.

NOTE:

Drain oil into a container.

- 4) Disconnect solenoid and sensor connectors. Remove connectors from clip and disconnect connectors at eight places.

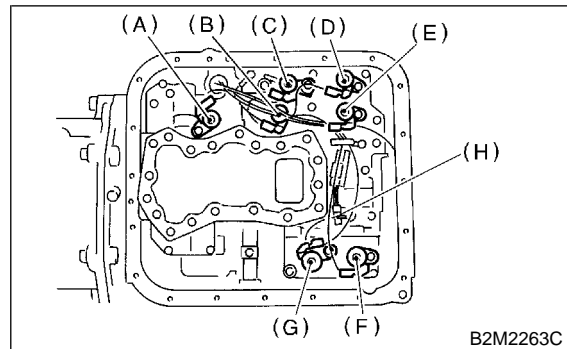

- (A) Lock-up duty solenoid (Blue)
- (B) Low clutch timing solenoid (Gray)
- (C) Line pressure duty solenoid (Red)
- (D) Shift solenoid 2 (Yellow)
- (E) Shift solenoid 1 (Green)
- (F) 2-4 brake timing solenoid (Black)
- (G) 2-4 brake duty solenoid (Red)
- (H) ATF temperature sensor