

21. Transfer Clutch

A: DISASSEMBLY

1) Remove the seal ring.

CAUTION:

Be careful not to damage the seal ring.

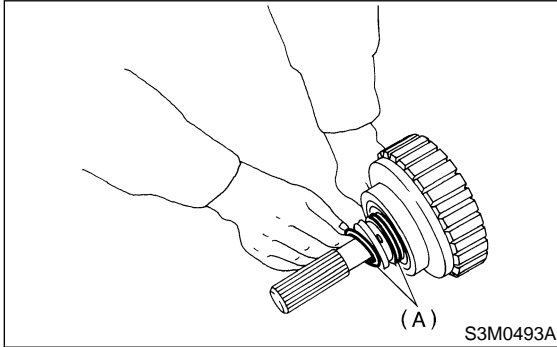

(A) Seal ring

2) Using a press and ST, remove the ball bearing.

CAUTION:

Do not reuse the bearing.

ST 498077600 REMOVER

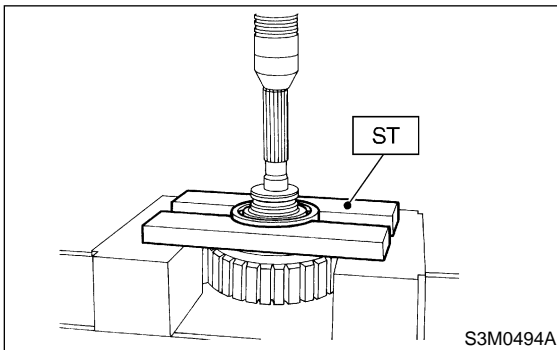

3) Remove the snap ring, and take out the pressure plate, drive plates, and driven plates.

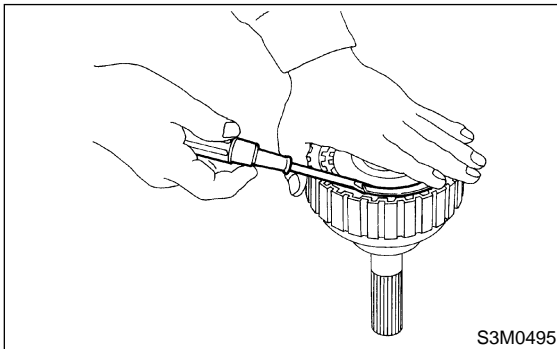

4) Remove the snap ring with ST1, ST2 and ST3, and take out the return ring spring and transfer clutch piston seal.

ST1 399893600 PLIERS

ST2 398673600 COMPRESSOR

ST3 398623600 SEAT

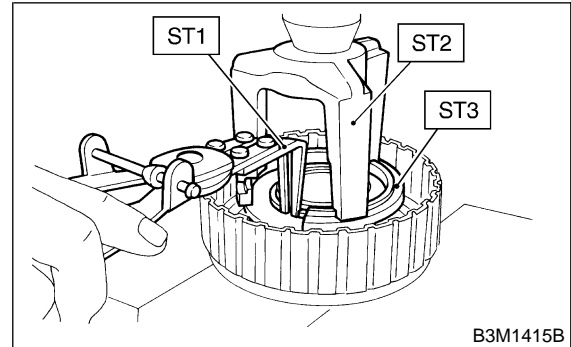

5) Apply compressed air to the rear drive shaft to remove the piston.

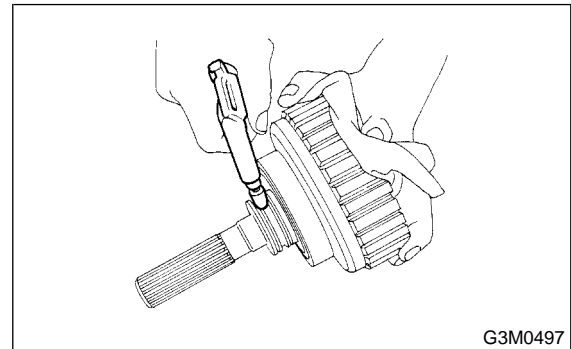

B: INSPECTION

- 1) Check the drive plate facing for wear and damage.
- 2) Check the snap ring for wear, return spring for permanent set and breakage, and return spring for deformation.
- 3) Check the lathe cut ring for damage.

C: ASSEMBLY

1) Install the transfer clutch piston.

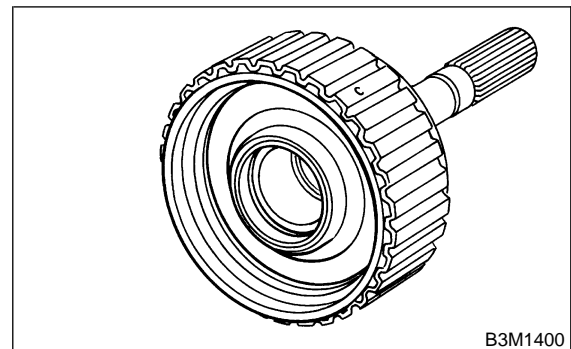

2) Install return spring to transfer piston.

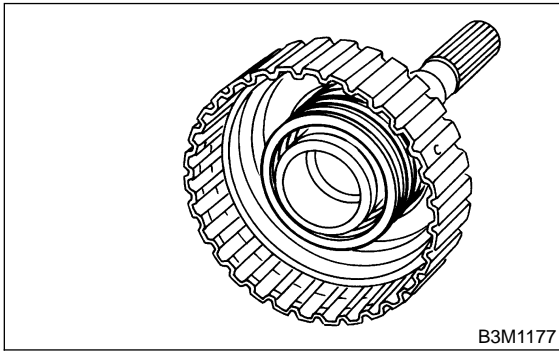

B3M1177

3) Install transfer clutch piston seal.

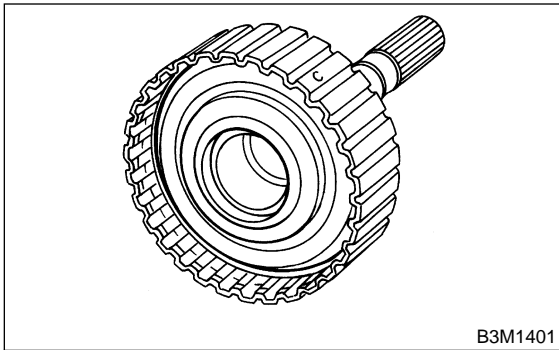

B3M1401

4) Install ST to rear drive shaft.

ST 499257300 SNAP RING OUTER GUIDE

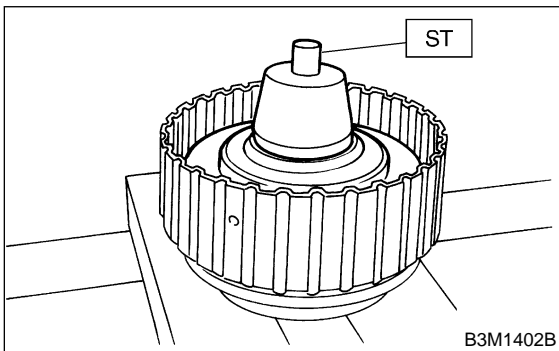

B3M1402B

5) Install snap ring to ST.

ST 499257300 SNAP RING OUTER GUIDE

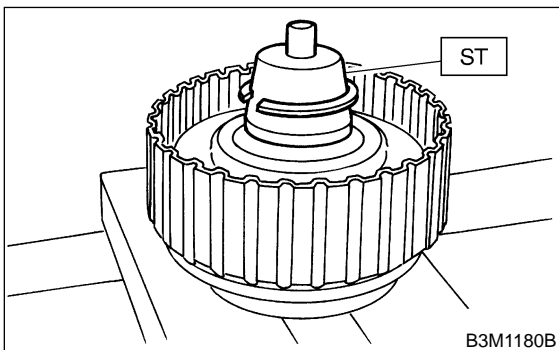

B3M1180B

6) Using ST1 and ST2, install snap ring to rear drive shaft.

NOTE:

After installing snap ring, remove ST1 and ST2.

ST1 499257300 SNAP RING OUTER GUIDE

ST2 499247400 INSTALLER

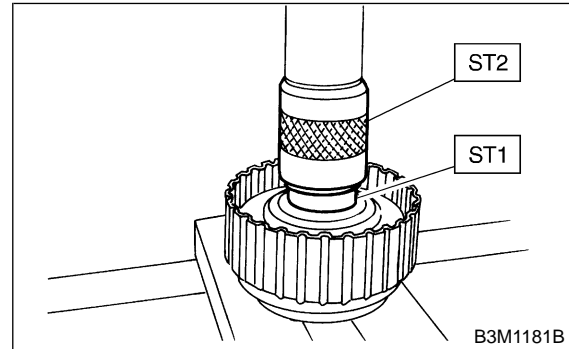

B3M1181B

7) Install the driven plates, drive plates, pressure plate and snap ring.

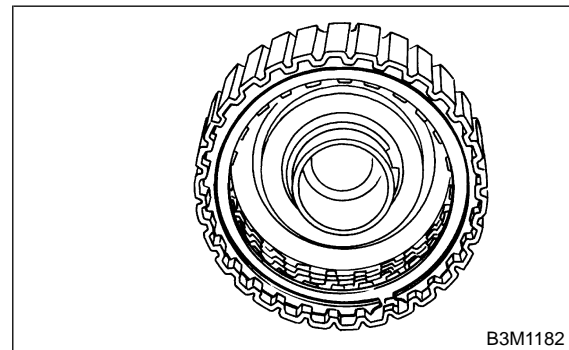

B3M1182

8) Apply compressed air to see if the assembled parts move smoothly.

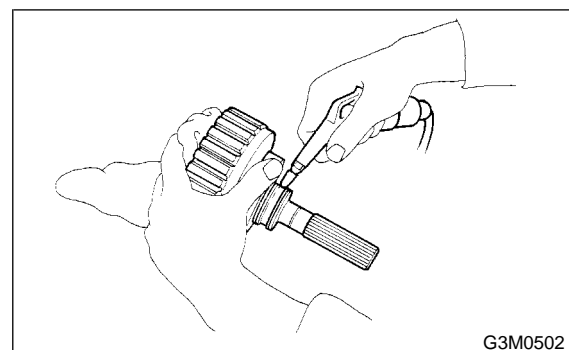

G3M0502

9) Check the clearance.

NOTE:

Before measuring clearance, place the same thickness of shim on both sides to prevent pressure plate from tilting.

If the clearance is not within the specified range, select a proper pressure plate.

Standard value:

0.2 — 0.6 mm (0.008 — 0.024 in)

Allowable limit:

1.6 mm (0.063 in)

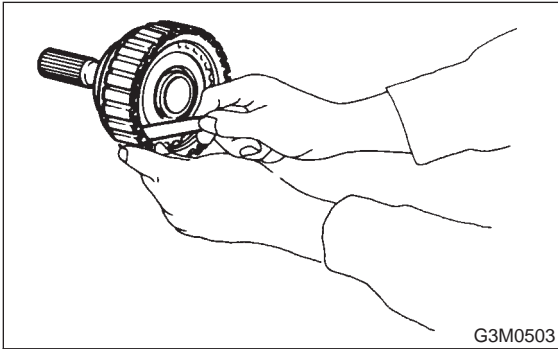

Available pressure plates	
Part No.	Thickness mm (in)
31593AA151	3.3 (0.130)
31593AA161	3.7 (0.146)
31593AA171	4.1 (0.161)
31593AA181	4.5 (0.177)

10) Press-fit the ball bearing with ST.

ST 899580100 INSTALLER

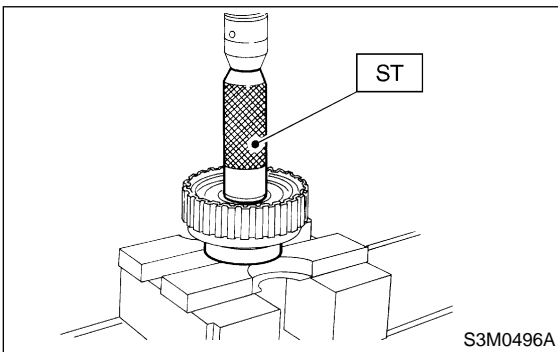

11) Coat the seal ring with vaseline, and install it in the seal ring groove of the shaft.

CAUTION:

Do not expand the seal ring excessively when installing.

ST 899580100 INSTALLER

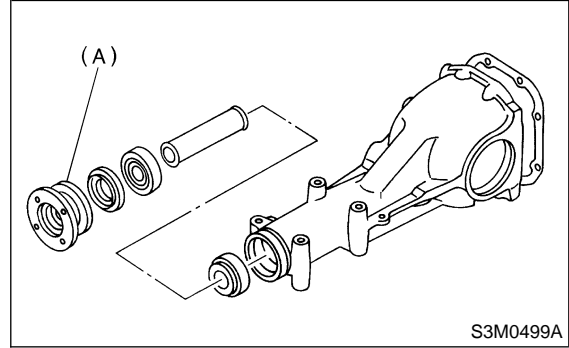

(A) Seal ring