

BODY SECTION

This service manual has been prepared to provide SUBARU service personnel with the necessary information and data for the correct maintenance and repair of SUBARU vehicles.

This manual includes the procedures for maintenance, disassembling, reassembling, inspection and adjustment of components and diagnostics for guidance of experienced mechanics.

Please peruse and utilize this manual fully to ensure complete repair work for satisfying our customers by keeping their vehicle in optimum condition. When replacement of parts during repair work is needed, be sure to use SUBARU genuine parts.

All information, illustration and specifications contained in this manual are based on the latest product information available at the time of publication approval.

FUJI HEAVY INDUSTRIES LTD.

**HVAC SYSTEM
(HEATER, VENTILATOR AND A/C) AC**

AIRBAG SYSTEM AB

SEAT BELT SYSTEM SB

LIGHTING SYSTEM LI

WIPER AND WASHER SYSTEMS WW

ENTERTAINMENT ET

COMMUNICATION SYSTEM COM

GLASS/WINDOWS/MIRRORS GW

BODY STRUCTURE BS

INSTRUMENTATION/DRIVER INFO IDI

SEATS SE

SECURITY AND LOCKS SL

**SUNROOF/T-TOP/CONVERTIBLE TOP
(SUNROOF) SR**

EXTERIOR/INTERIOR TRIM EI

EXTERIOR BODY PANELS EB

CRUISE CONTROL SYSTEM CC

SECURITY AND LOCKS

SL

	Page
1. General Description.....	2
2. Door Lock Control System.....	8
3. Keyless Entry System.....	14
4. Front Inner Remote.....	27
5. Front Outer Handle.....	28
6. Front Door Latch Assembly.....	29
7. Front Door Lock Actuator.....	30
8. Rear Inner Remote.....	31
9. Rear Outer Handle.....	32
10. Rear Door Latch Assembly.....	33
11. Rear Door Lock Actuator.....	34
12. Rear Gate Outer Handle.....	35
13. Rear Gate Latch Assembly.....	36
14. Rear Gate Latch Lock Actuator.....	37
15. Front Hood Lock Assembly.....	38
16. Remote Openers.....	39
17. Ignition Key Lock.....	40
18. Key Lock Cylinders.....	41
19. Immobilizer Control Module.....	42
20. Immobilizer Antenna.....	43
21. Keyless Entry Control Module.....	44
22. Keyless Transmitter.....	45

GENERAL DESCRIPTION

Security and Locks

1. General Description S909001

A: SPECIFICATIONS S909001E49

B: COMPONENT S909001A05

1. DOOR LOCK ASSEMBLY S909001A0501

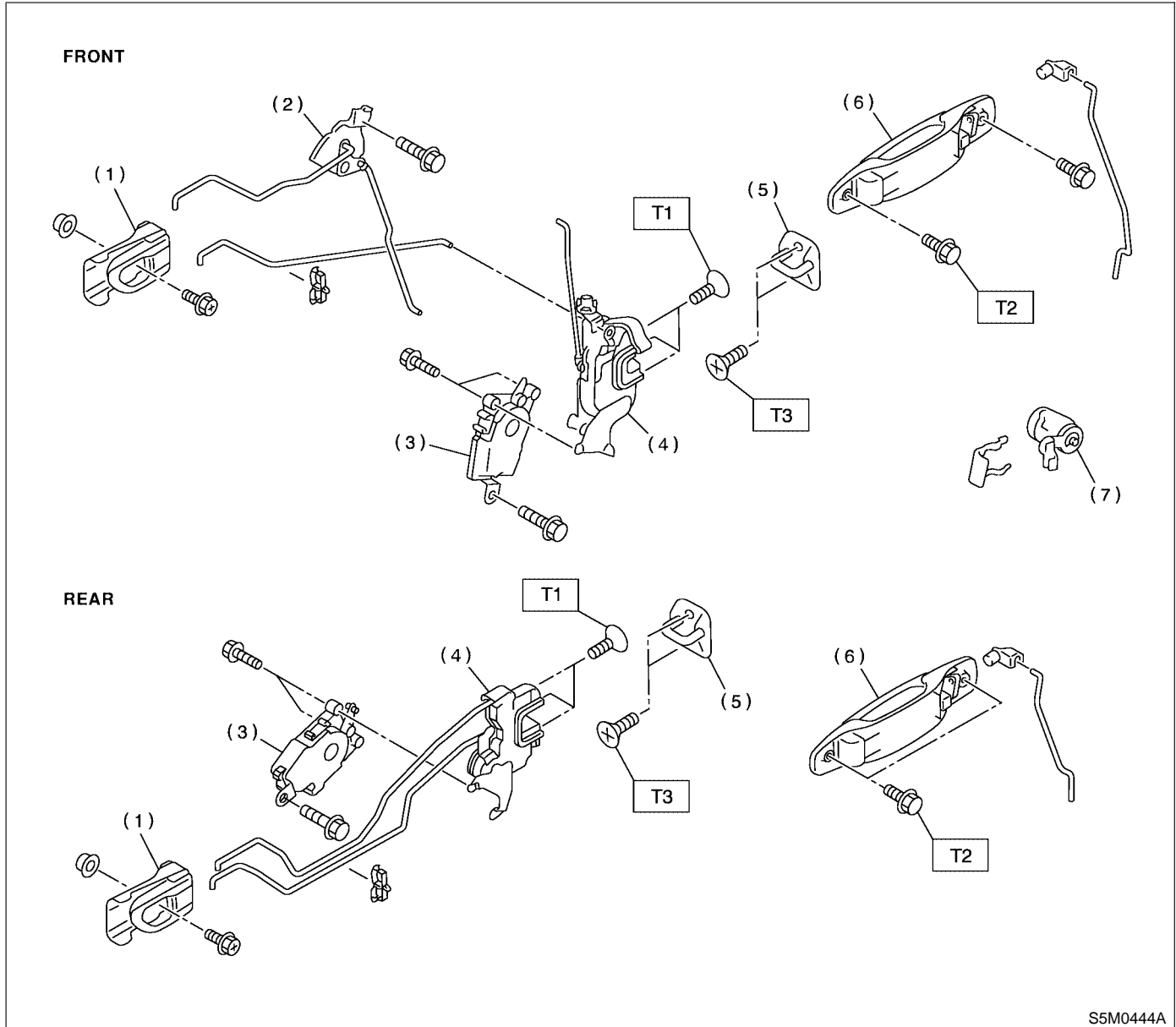

- (1) Inner remote ASSY
- (2) Bell crank
- (3) Auto-door lock actuator
- (4) Door latch
- (5) Striker

- (6) Door outer handle
- (7) Key cylinder

Tightening torque: N·m (kgf·m, ft·lb)

T1: 6.4 (0.65, 4.7)

T2: 7.4 (0.75, 5.4)

T3: 14 (1.4, 10.1)

2. REAR GATE LOCK S909001A0502

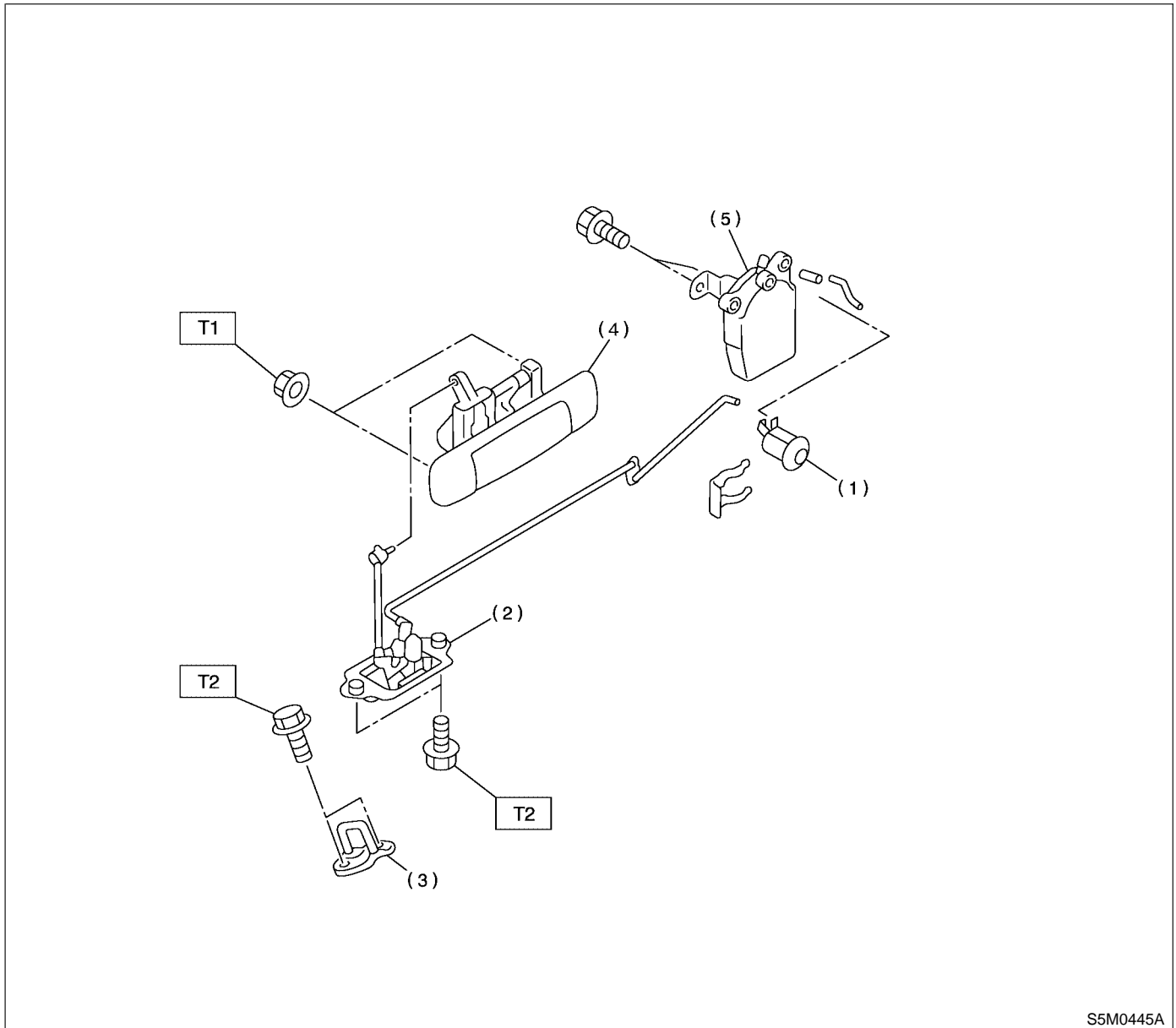

S5M0445A

- (1) Key cylinder
- (2) Rear gate latch
- (3) Striker
- (4) Rear gate outer handle

- (5) Rear gate actuator

Tightening torque: N·m (kgf·m, ft·lb)

T1: 7.4 (0.75, 5.4)

T2: 25 (2.5, 18.1)

GENERAL DESCRIPTION

Security and Locks

3. HOOD LOCK AND REMOTE OPENERS S909001A0503

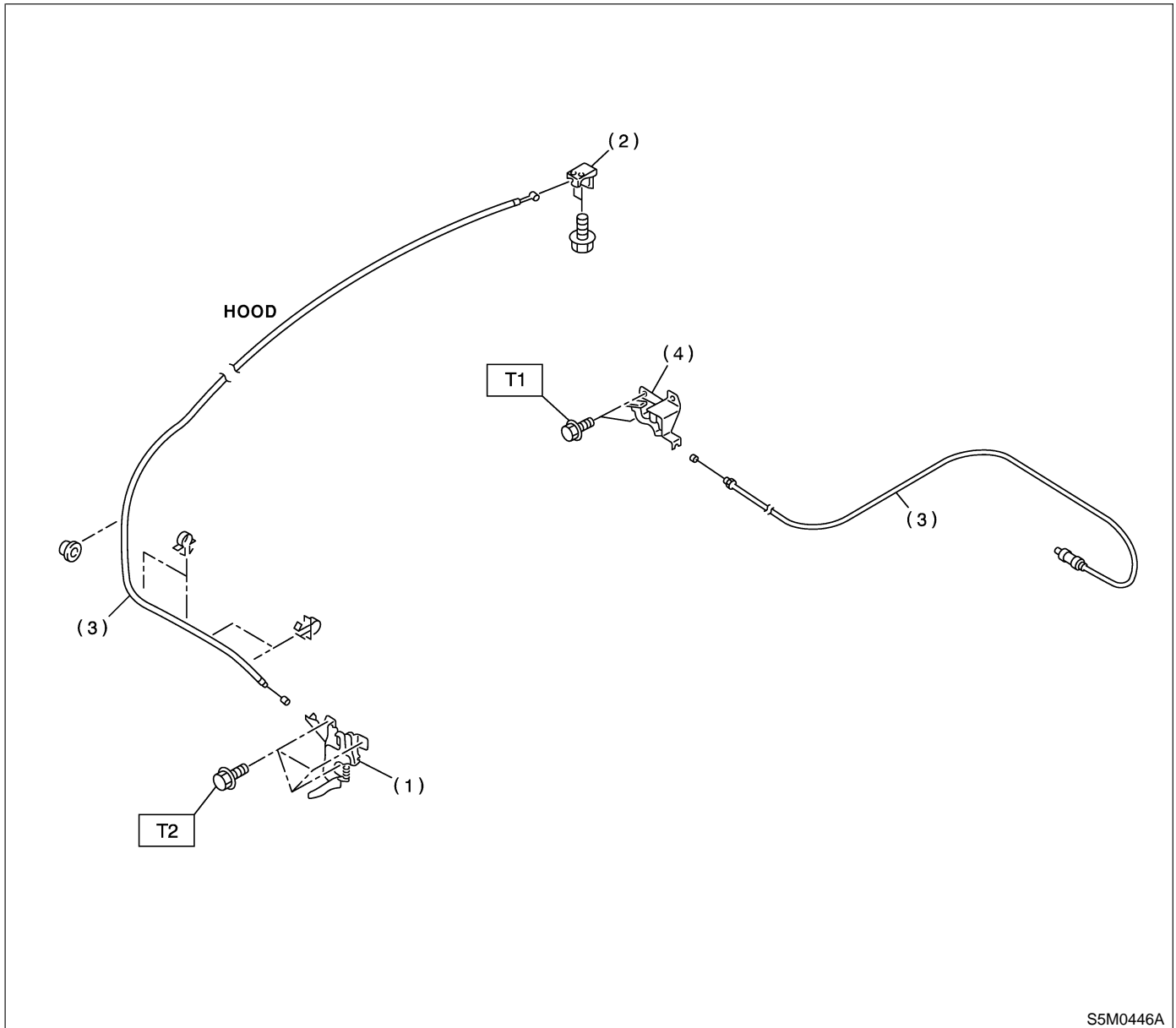

- (1) Hood lock ASSY
- (2) Lever ASSY
- (3) Cable

- (4) Pull handle ASSY

Tightening torque: N·m (kgf·m, ft·lb)

T1: 6.4 (0.65, 4.7)

T2: 32 (3.3, 23.9)

4. IMMOBILIZER SYSTEM S909001A0509

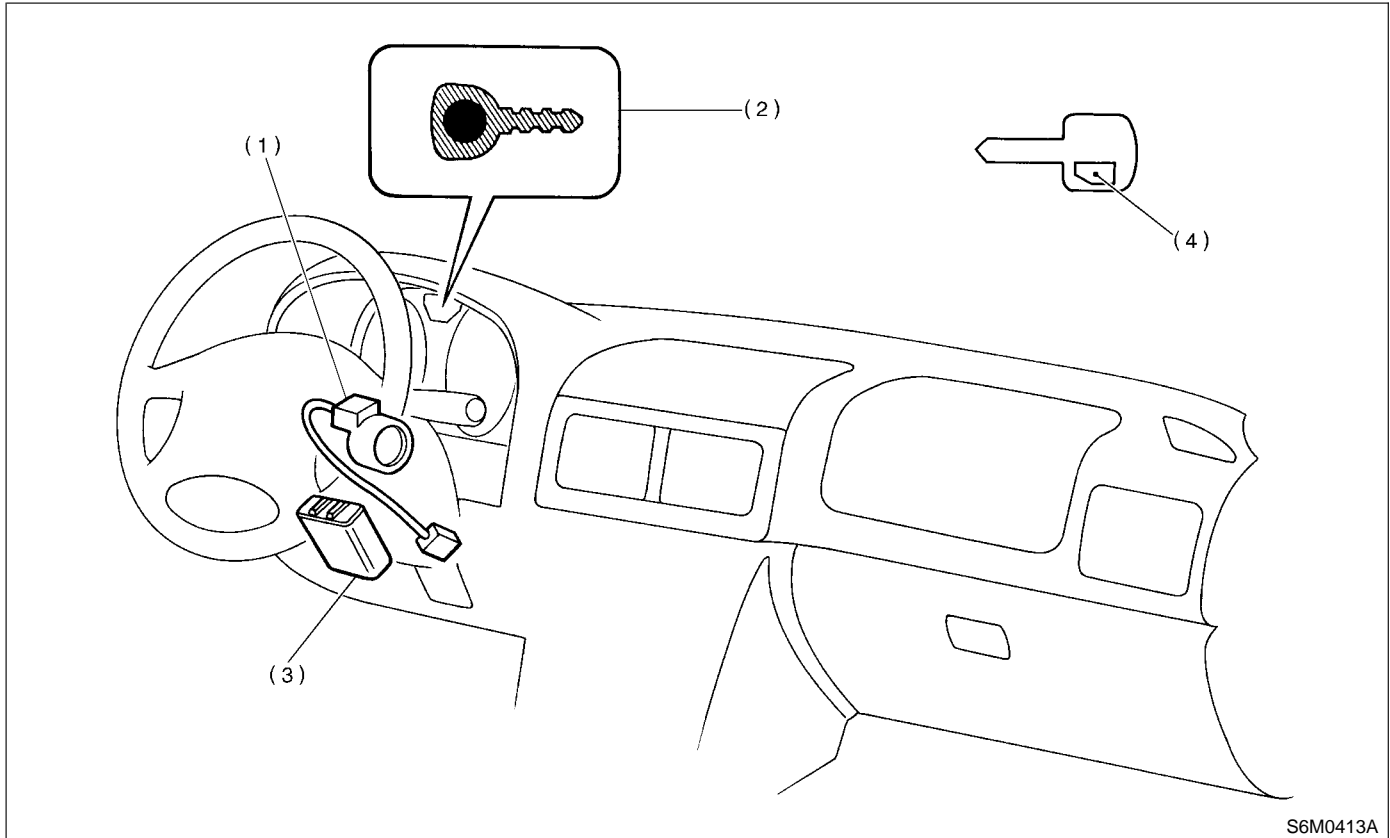

S6M0413A

- | | |
|---|--|
| (1) Antenna | (3) Immobilizer control module (IMM
ECM): LHD model |
| (2) Immobilizer indicator light (LED
bulb) | (4) Transponder |

NOTE:
IMM ECM location for RHD model is symmetrically
opposite.

GENERAL DESCRIPTION

Security and Locks

5. KEYLESS ENTRY SYSTEM S909001A0505

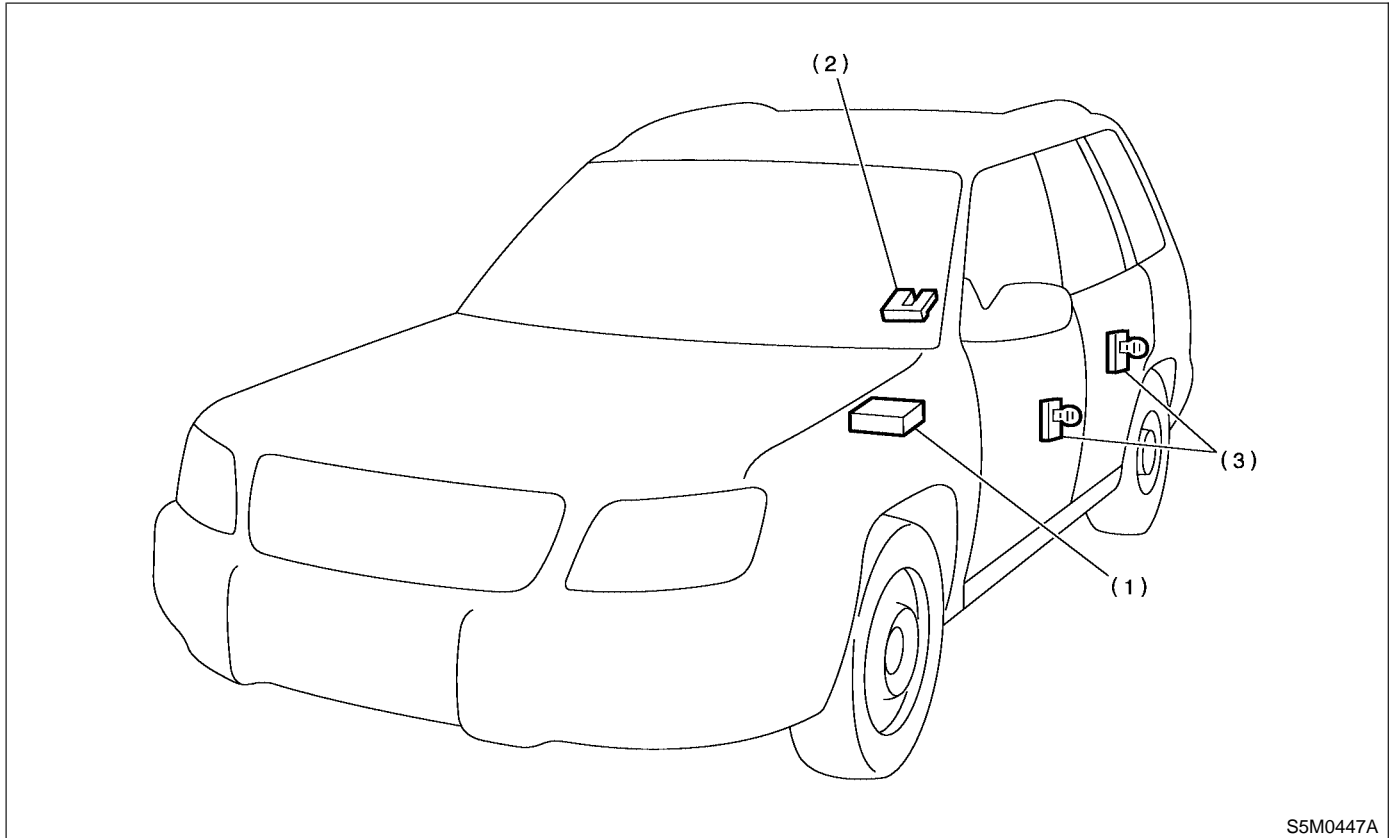

S5M0447A

(1) Keyless entry control module

(2) Rear gate latch switch

(3) Door switch

C: CAUTION S909001A03

- Before disassembling or reassembling parts, always disconnect battery ground cable. When repairing radio, control module, etc. which are provided with memory functions, record memory contents before disconnecting battery ground cable. Otherwise, these contents are cancelled upon disconnection.
- Reassemble parts in reverse order of disassembly procedure unless otherwise indicated.
- Adjust parts to specifications contained in this manual if so designated.
- Connect connectors and hoses securely during reassembly.
- After reassembly, ensure functional parts operate smoothly.
- Airbag system wiring harness is routed near the electrical parts and switch.
- All airbag system wiring harness and connectors are colored yellow. Do not use electrical test equipment on these circuits.
- Be careful not to damage Airbag system wiring harness when servicing the ignition key cylinder.

D: PREPARATION TOOL S909001A17

1. SPECIAL TOOLS S909001A1701

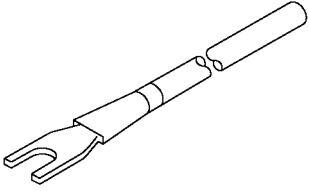
ILLUSTRATION	TOOL NUMBER	DESCRIPTION	REMARKS
 <p style="text-align: right; font-size: small;">B5M1120</p>	925580000	PULLER	Used for removing trim clip

2. GENERAL TOOLS S909001A1702

TOOL NAME	REMARKS
Circuit Tester	Used for measuring resistance and voltage.
Drill	Used for replacing ignition key lock.

DOOR LOCK CONTROL SYSTEM

Security and Locks

2. Door Lock Control System

S909348

A: SCHEMATIC

S909348A21

1. DOOR LOCK CONTROL LHD MODEL

S909348A2106

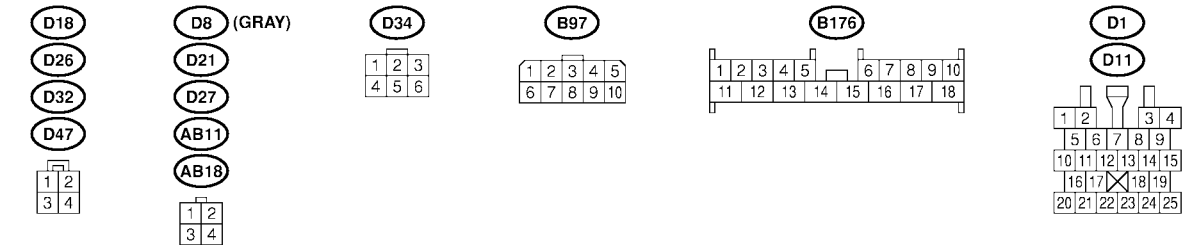
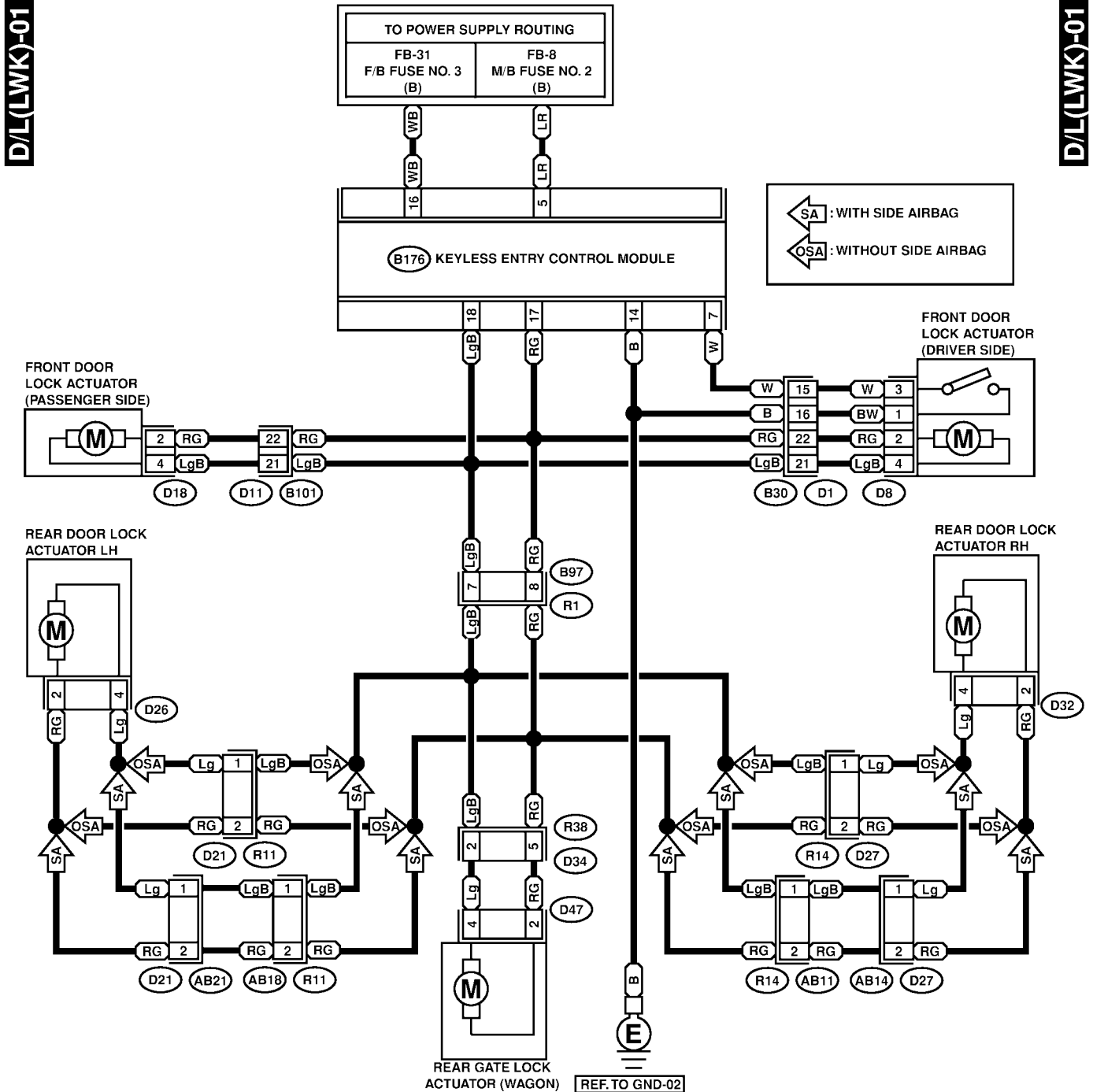

SL73-20

DOOR LOCK CONTROL SYSTEM

Security and Locks

2. DOOR LOCK CONTROL RHD MODEL S909348A2107

D/L(RWK)-01

D/L(RWK)-01

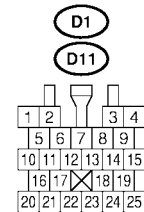
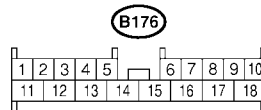
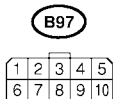
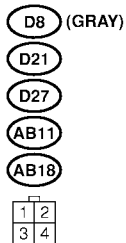
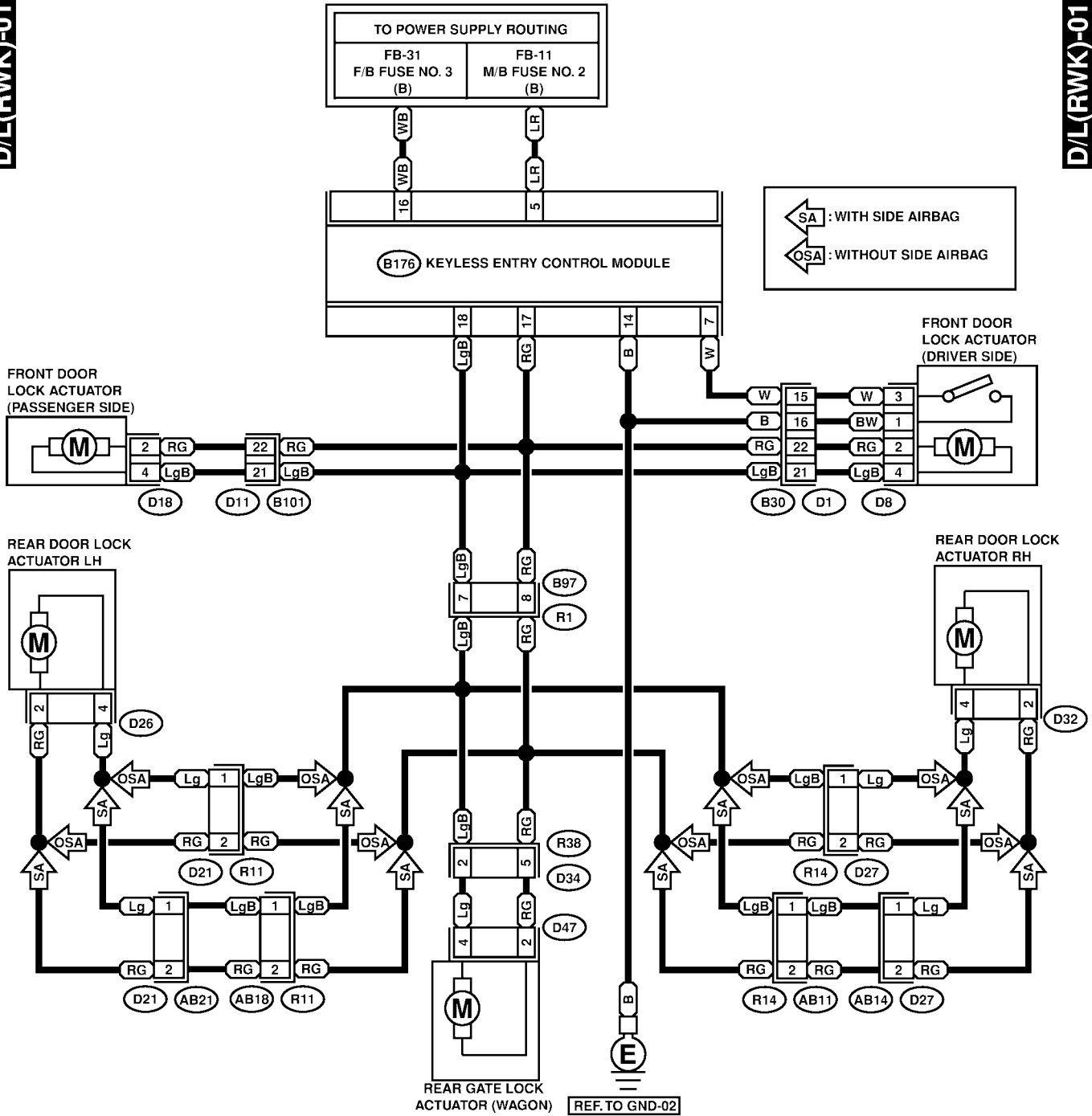

SR73-20

DOOR LOCK CONTROL SYSTEM

Security and Locks

B: INSPECTION S909348A10

1. SYMPTOM CHART S909348A1001

Symptom	Repair order	Reference
The door lock control system does not operate.	1. Check the fuse.	<Ref. to SL-10 CHECK FUSE, INSPECTION, Door Lock Control System.>
	2. Check the power supply and ground circuit for the keyless entry control module.	<Ref. to SL-11 CHECK POWER SUPPLY AND GROUND CIRCUIT, INSPECTION, Door Lock Control System.>
	3. Check the door lock switch and the circuit.	<Ref. to SL-11 CHECK DOOR LOCK SWITCH AND CIRCUIT, INSPECTION, Door Lock Control System.>
	4. Check the door lock actuator and the circuit.	<Ref. to SL-12 CHECK DOOR LOCK ACTUATOR AND CIRCUIT, INSPECTION, Door Lock Control System.>
The door lock switch (knob) does not operate.	Check the door lock switch and the circuit.	<Ref. to SL-11 CHECK DOOR LOCK SWITCH AND CIRCUIT, INSPECTION, Door Lock Control System.>
A specific door lock actuator does not operate.	Check the door lock actuator and the circuit.	<Ref. to SL-12 CHECK DOOR LOCK ACTUATOR AND CIRCUIT, INSPECTION, Door Lock Control System.>

2. CHECK FUSE S909348A1002

No.	Step	Check	Yes	No
1	CHECK FUSE. Remove and visually check fuse No. 2 (in the main fuse box) and No. 3 (in the fuse and relay box).	Is the fuse blown (15A)?	Replace the fuse with a new one.	Check power supply and ground circuit. <Ref. to SL-11 CHECK POWER SUPPLY AND GROUND CIRCUIT, INSPECTION, Door Lock Control System.>

3. CHECK POWER SUPPLY AND GROUND CIRCUIT

S909348A1003

No.	Step	Check	Yes	No
1	CHECK POWER SUPPLY. 1) Disconnect the door lock timer or keyless entry control module harness connector. 2) Measure the voltage between the harness connector terminal and chassis ground. Connector & terminal (B176) No. 5 (+) — Chassis ground (-): (B176) No. 16 (+) — Chassis ground (-):	Is the voltage more than 10 V?	Go to step 2.	Check the harness for open circuits or shorts between the keyless entry control module and the fuse.
2	CHECK GROUND CIRCUIT. Measure the resistance between the harness connector terminal and chassis ground. Connector & terminal (B176) No. 14 (+) — Chassis ground (-):	Is the resistance less than 10 Ω?	Power supply and ground circuit is OK.	Repair harness.

4. CHECK DOOR LOCK SWITCH AND CIRCUIT

S909348A1004

No.	Step	Check	Yes	No
1	CHECK DOOR LOCK SWITCH CIRCUIT. 1) Disconnect the keyless entry control module harness connector. 2) Measure the resistance between the harness connector terminal and chassis ground when moving the driver's door lock knob to UNLOCK. Connector & terminal (B176) No. 7 (+) — Chassis ground (-):	Is the resistance less than 10 Ω?	Go to step 2.	Go to step 3.
2	CHECK DOOR LOCK SWITCH CIRCUIT. Measure the resistance between the harness connector terminal and chassis ground when the driver's door lock knob is moved to LOCK. Connector & terminal (B176) No. 7 (+) — Chassis ground (-):	Is the resistance less than 10 Ω?	Go to step 3.	The door lock switch is OK.
3	CHECK DOOR LOCK SWITCH. 1) Disconnect the driver's door lock switch (actuator) harness connector. 2) Check the continuity between the door lock switch terminals when moving the door lock knob to UNLOCK. Terminal No. 1 — No. 3:	Does continuity exist?	Go to step 4.	Replace the door lock switch (actuator).
4	CHECK DOOR LOCK SWITCH. Check the continuity between the door lock switch terminals when moving the door lock knob to LOCK. Terminal No. 1 — No. 3:	Does continuity exist?	Replace the door lock switch (actuator).	Check the harness for open circuits or shorts between the keyless entry control module and the door lock switch.

DOOR LOCK CONTROL SYSTEM

Security and Locks

5. CHECK DOOR LOCK ACTUATOR AND CIRCUIT

S909346A1005

No.	Step	Check	Yes	No
1	<p>CHECK OUTPUT SIGNAL. Measure the voltage between the harness connector terminal and chassis ground when moving the door lock knob to LOCK.</p> <p>Connector & terminal (B176) No. 18 (+) — Chassis ground (-):</p>	Is the voltage more than 10 V?	Go to step 2.	Replace the keyless entry control module.
2	<p>CHECK OUTPUT SIGNAL. Measure the voltage between the harness connector terminal and chassis ground when moving the door lock knob to UNLOCK.</p> <p>Connector & terminal (B176) No. 17 (+) — Chassis ground (-):</p>	Is the voltage more than 10 V?	Go to step 3.	Replace the keyless entry control module.
3	<p>CHECK DOOR LOCK ACTUATOR. Check the door lock actuator. Front door lock actuator: <Ref. to SL-30 Front Door Lock Actuator.> Rear door lock actuator: <Ref. to SL-34 Rear Door Lock Actuator.> Rear gate latch lock actuator: <Ref. to SL-37 Rear Gate Latch Lock Actuator.></p>	Is the door lock actuator OK?	Check the harness for open circuits or shorts between the keyless entry control module and the door lock actuator.	Replace the door lock actuator.

MEMO:

KEYLESS ENTRY SYSTEM

Security and Locks

3. Keyless Entry System S909345

A: SCHEMATIC S909345A21

1. KEYLESS ENTRY LHD MODEL S909345A2101

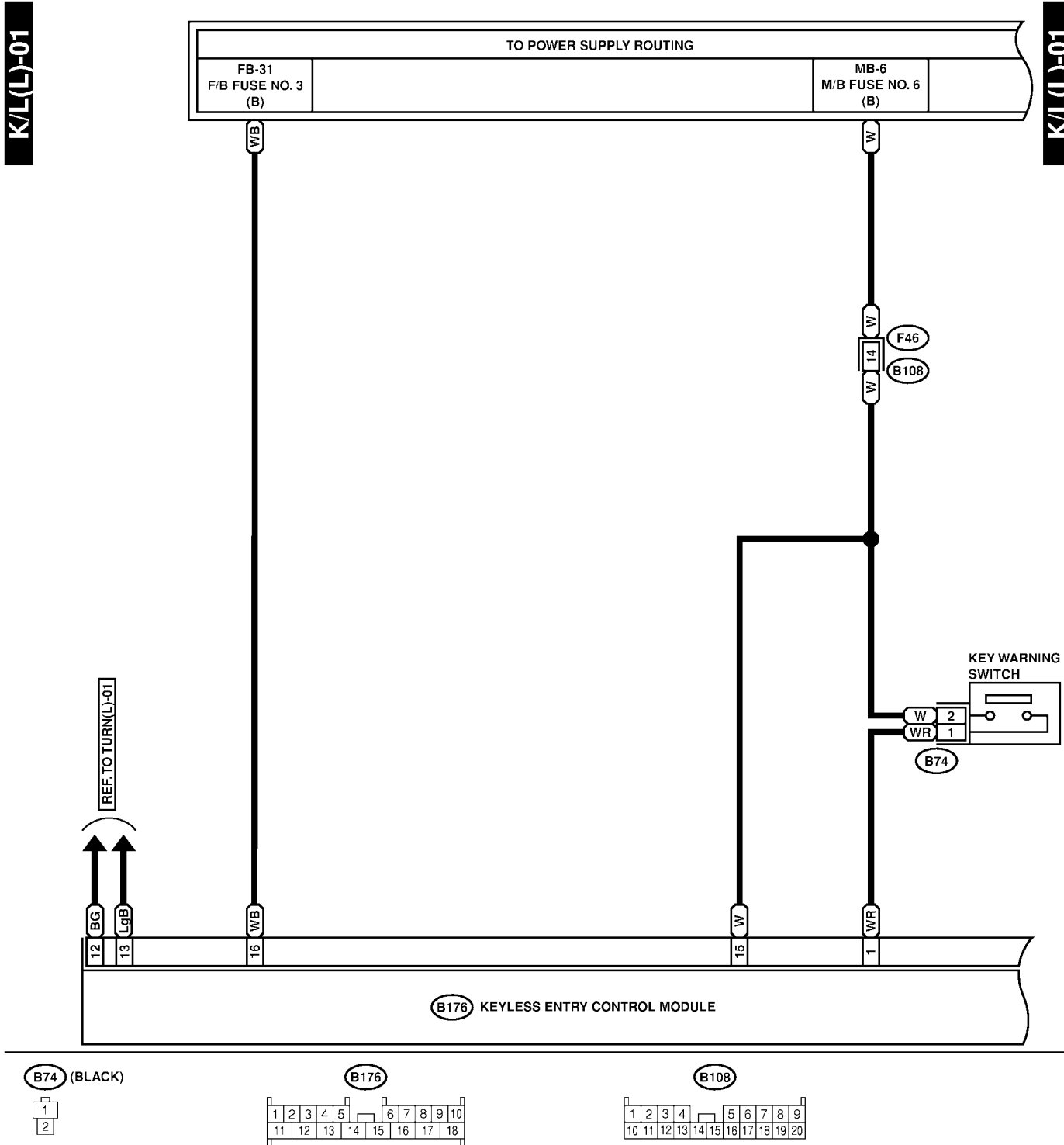

KEYLESS ENTRY SYSTEM

Security and Locks

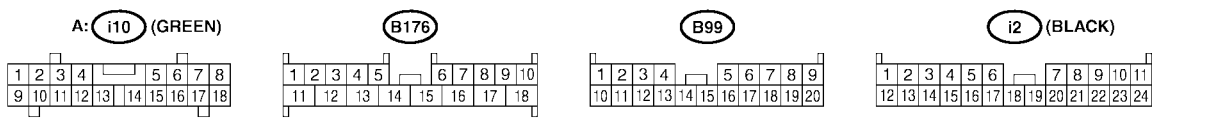
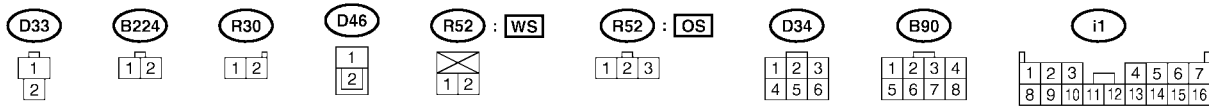
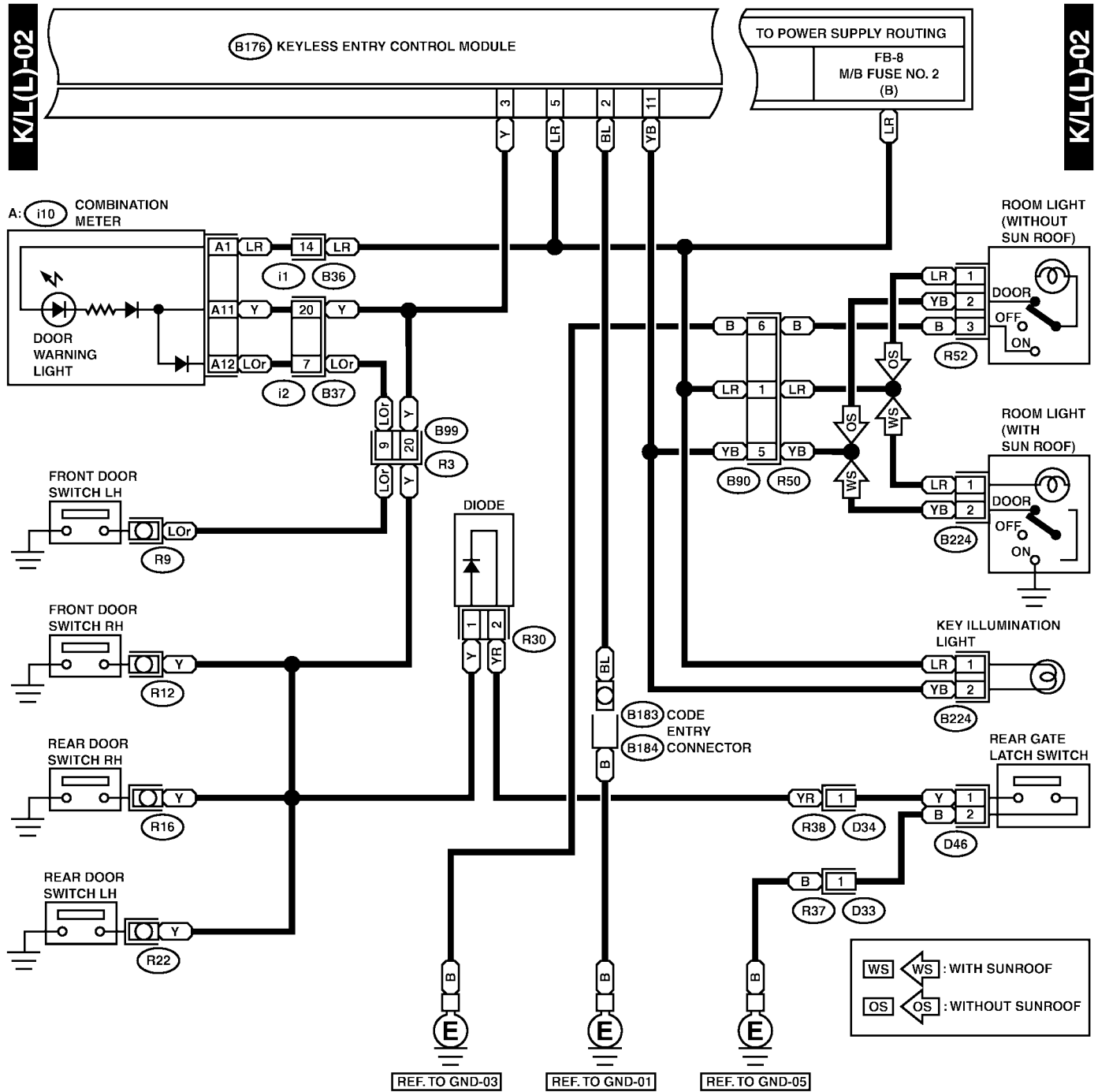

SL77-20B

KEYLESS ENTRY SYSTEM

Security and Locks

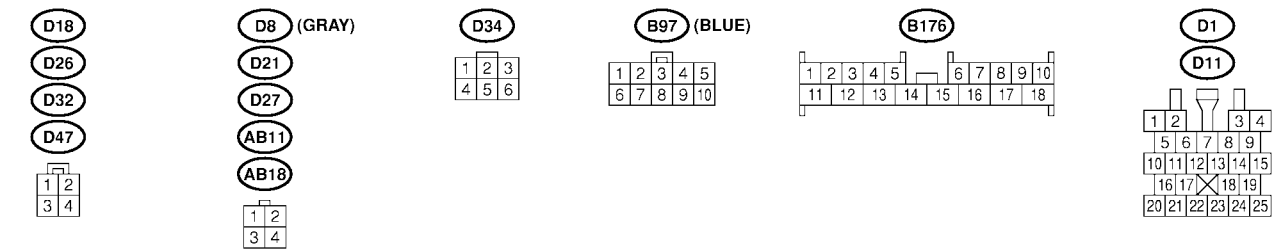
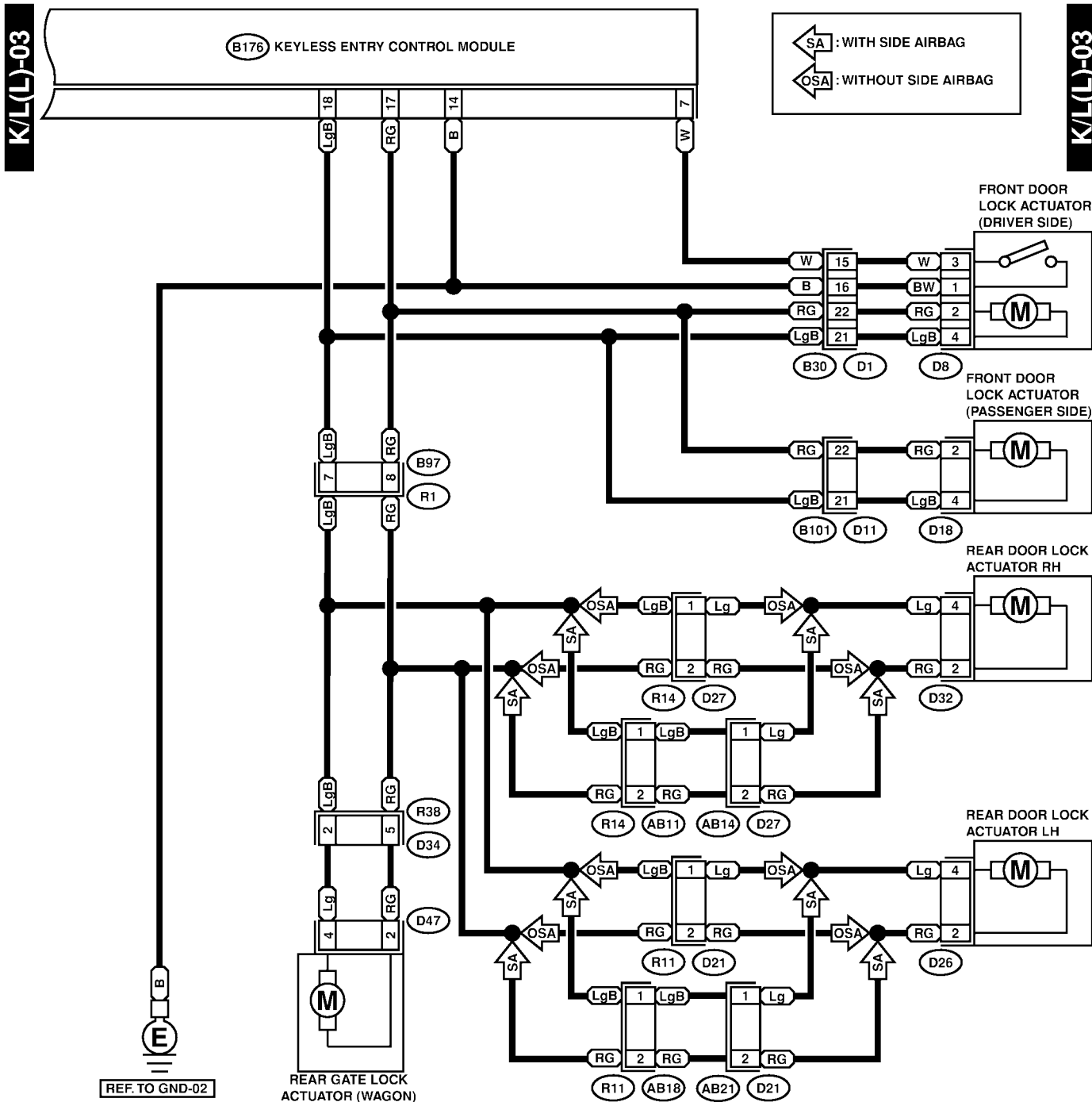

2. KEYLESS ENTRY RHD MODEL S909345A2.102

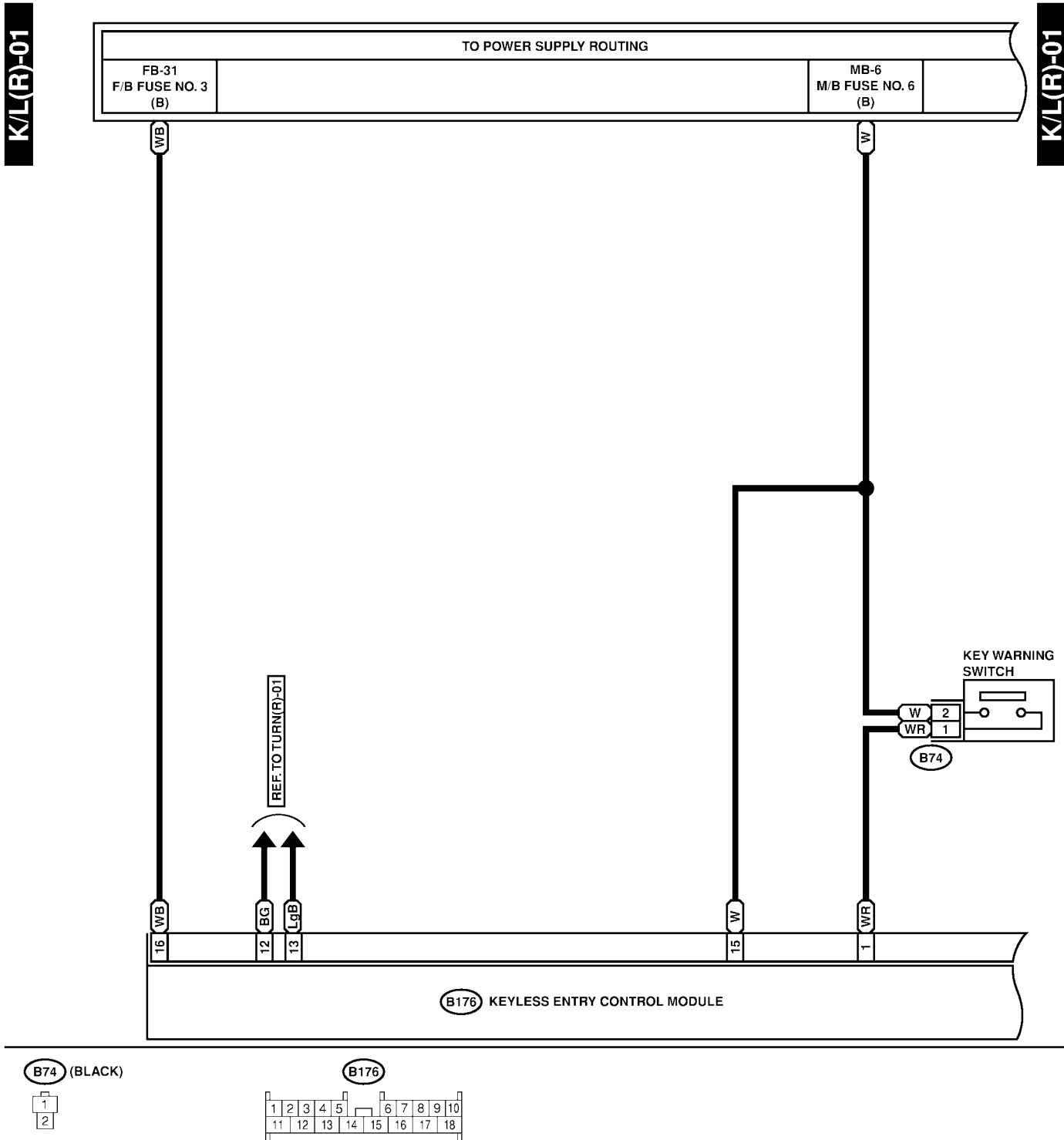

KEYLESS ENTRY SYSTEM

Security and Locks

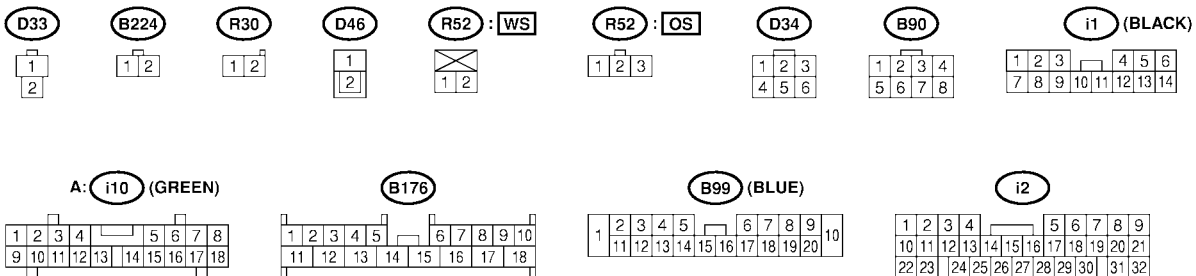
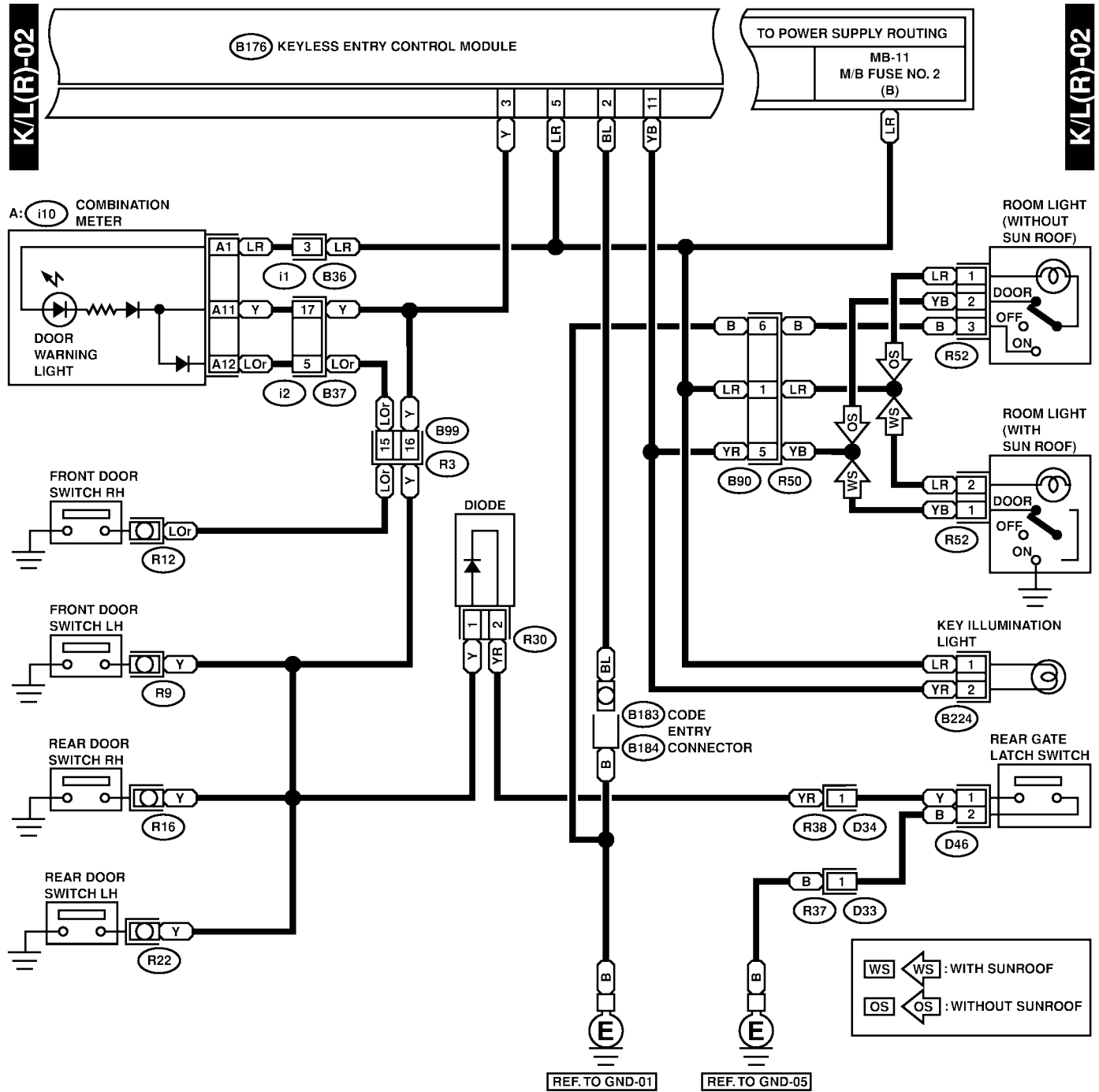

SR77-20B

KEYLESS ENTRY SYSTEM

Security and Locks

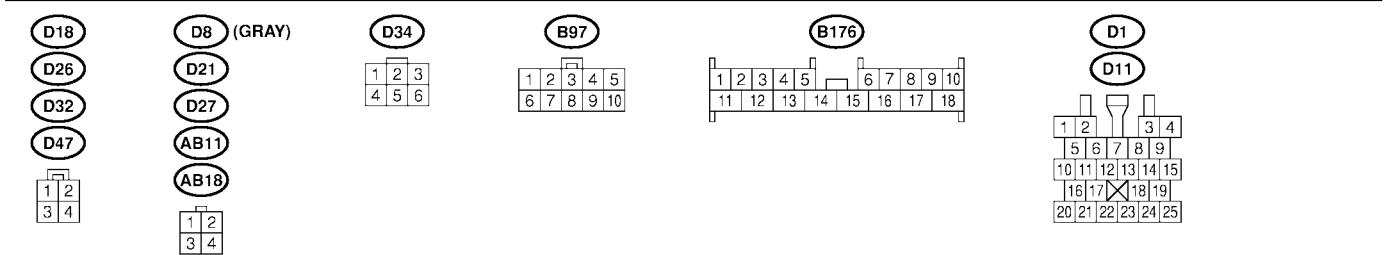
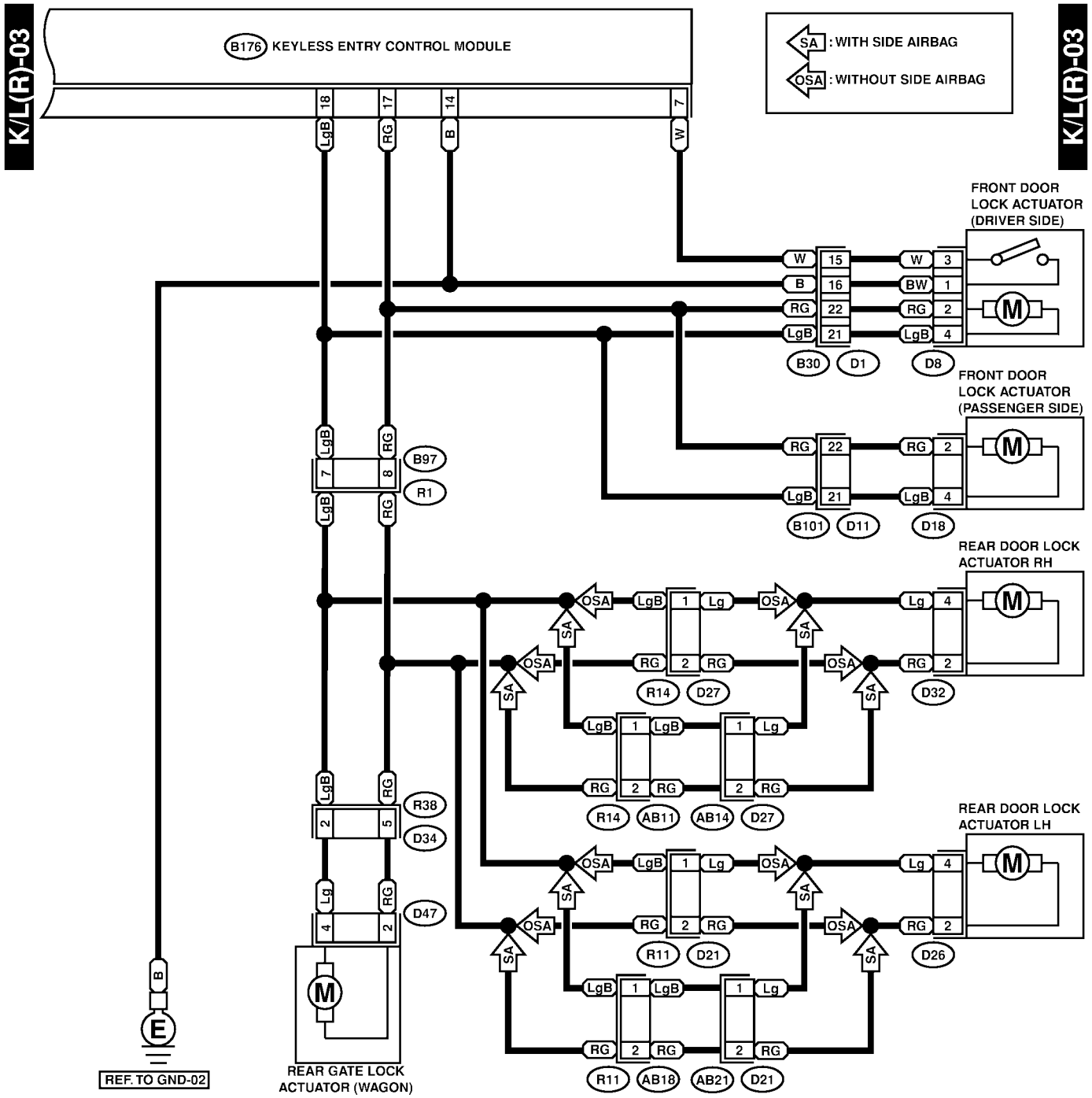

KEYLESS ENTRY SYSTEM

Security and Locks

B: ELECTRICAL SPECIFICATION S909345A08

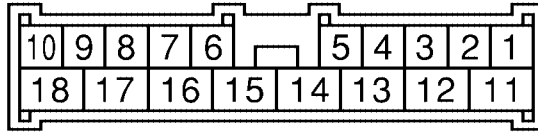

B5M1141

Content	Terminal No.	Measuring condition
Key warning switch	1 (INPUT)	Battery voltage is present when inserting the key into the ignition switch.
Registration connector	2 (INPUT)	0 V is present when connecting the registration connector.
Door switch	3 (INPUT)	0 V is present when any door is open.
Empty	4	—
Power supply	5	Battery voltage is constantly present.
Empty	6	—
Door lock switch	7 (INPUT)	0 V is present when driver's door is unlocked.
Empty	8	—
Empty	9	—
Empty	10	—
Room light/Ignition switch illumination	11 (OUTPUT)	<ul style="list-style-type: none"> ● 0 V is present when pressing the transmitter OPEN button. ● 0 V is present when any door is open.
Turn signal light (Right)	12 (OUTPUT)	Battery voltage is present when pressing the transmitter OPEN or LOCK button.
Turn signal light (Left)	13 (OUTPUT)	Battery voltage is present when pressing the transmitter OPEN or LOCK button.
Ground	14	0 V is constantly present.
Power supply (Hazard light)	15	Battery voltage is constantly present.
Power supply	16	Battery voltage is constantly present.
Door and rear gate lock actuator (Unlock)	17 (OUTPUT)	Battery voltage is present when pressing the transmitter OPEN button.
Door and rear gate lock actuator (Lock)	18 (OUTPUT)	Battery voltage is present when pressing the transmitter LOCK button.

C: INSPECTION S909345A10

1. SYMPTOM CHART S909345A1001

Symptom	Repair order	Reference
None of the functions of the keyless entry system operate.	1. Check the transmitter battery.	<Ref. to SL-22 CHECK TRANSMITTER BATTERY, INSPECTION, Keyless Entry System.>
	2. Check the fuse.	<Ref. to SL-22 CHECK FUSE, INSPECTION, Keyless Entry System.>
	3. Check the keyless entry control module power supply and ground circuit.	<Ref. to SL-23 CHECK POWER SUPPLY AND GROUND CIRCUIT, INSPECTION, Keyless Entry system.>
	4. Replace the keyless entry control module.	<Ref. to SL-44 Keyless Entry Control Module.>
The transmitter cannot be registered.	1. Check the transmitter battery.	<Ref. to SL-22 CHECK TRANSMITTER BATTERY, INSPECTION, Keyless Entry System.>
	2. Check the registration connector circuit.	<Ref. to SL-23 CHECK REGISTRATION CONNECTOR CIRCUIT, INSPECTION, Keyless Entry System.>
	3. Replace the keyless entry control module.	<Ref. to SL-44 Keyless Entry Control Module.>
The door lock or unlock does not operate. NOTE: If the door lock control system does not operate when using the door lock switch, check the door lock control system. <Ref. to SL-10 INSPECTION, Door Lock Control System.>	1. Check the transmitter battery.	<Ref. to SL-22 CHECK TRANSMITTER BATTERY, INSPECTION, Keyless Entry System.>
	2. Check the key warning switch.	<Ref. to SL-24 CHECK KEY WARNING SWITCH, INSPECTION, Keyless Entry System.>
	3. Check the door switch.	<Ref. to SL-24 CHECK DOOR SWITCH, INSPECTION, Keyless Entry System.>
	4. Replace the keyless entry control module.	<Ref. to SL- 44 Keyless Entry Control Module.>
The hazard light does not operate.	1. Check the transmitter battery	<Ref. to SL-22 CHECK TRANSMITTER BATTERY, INSPECTION, Keyless Entry System.>
	2. Check the key warning switch.	<Ref. to SL-24 CHECK KEY WARNING SWITCH, INSPECTION, Keyless Entry System.>
	3. Check the door switch.	<Ref. to SL-24 CHECK DOOR SWITCH, INSPECTION, Keyless Entry System.>
	4. Check the hazard light operation.	<Ref. to SL-25 CHECK HAZARD LIGHT OPERATION, INSPECTION, Keyless Entry System.>
	5. Replace the keyless entry control module.	<Ref. to SL-44 Keyless Entry Control Module.>

KEYLESS ENTRY SYSTEM

Security and Locks

Symptom	Repair order	Reference
The room light and ignition switch illumination operation does not activate.	1. Check the transmitter battery.	<Ref. to SL-22 CHECK TRANSMITTER BATTERY, INSPECTION, Keyless Entry System.>
	2. Check the room light operation.	<Ref. to SL-26 CHECK ROOM LIGHT OPERATION, INSPECTION, Keyless Entry System.>
	3. Check the ignition switch illumination circuit.	<Ref. to SL-26 CHECK IGNITION SWITCH ILLUMINATION CIRCUIT, INSPECTION, Keyless Entry System.>
	4. Check the key warning switch.	<Ref. to SL-24 CHECK KEY WARNING SWITCH, INSPECTION, Keyless Entry System.>
	5. Check the door switch.	<Ref. to SL-24 CHECK DOOR SWITCH, INSPECTION, Keyless Entry System.>
	6. Replace the keyless entry control module.	<Ref. to SL-44 Keyless Entry Control Module.>

2. CHECK TRANSMITTER BATTERY S909345A1011

No.	Step	Check	Yes	No
1	CHECK TRANSMITTER BATTERY. 1) Remove the battery from the transmitter. <Ref. to SL-45 REMOVAL, Keyless Transmitter.> 2) Check the battery voltage. <Ref. to SL-45 INSPECTION, Keyless Transmitter.>	Is the battery voltage OK?	Further inspection is necessary, refer to "SYMPTOM CHART". <Ref. to SL-21 SYMPTOM CHART, INSPECTION, Keyless Entry System.>	Replace the transmitter battery.

3. CHECK FUSE S909345A1004

No.	Step	Check	Yes	No
1	CHECK FUSE. Remove and visually check fuse No. 2 (in the main fuse box), No. 3 (in the fuse and relay box) and SBF-6 (in the main fuse box)	Is the fuse blown? (15 A and 30 A)	Replace the fuse with a new one.	Check power supply and ground circuit. <Ref. to SL-23 CHECK POWER SUPPLY AND GROUND CIRCUIT, INSPECTION, Keyless Entry system.>

4. CHECK POWER SUPPLY AND GROUND CIRCUIT S909345A1005

No.	Step	Check	Yes	No
1	CHECK POWER SUPPLY. 1) Disconnect the keyless entry control module harness connector. 2) Measure the voltage between the harness connector terminal and chassis ground. <i>Connector & terminal</i> <i>(B176) No. 5, No. 15, No. 16 (+) — Chassis ground (-):</i>	Is the voltage more than 10 V?	Go to step 2.	Check the harness for open circuits or shorts between the keyless entry control module and fuse.
2	CHECK GROUND CIRCUIT. Measure the resistance between the harness connector terminal and chassis ground. <i>Connector & terminal</i> <i>(B176) No. 14 (+) — Chassis ground (-):</i>	Is the resistance less than 10 Ω?	The power supply and ground circuit are OK.	Repair the harness.

5. CHECK REGISTRATION CONNECTOR CIRCUIT S909345A1012

No.	Step	Check	Yes	No
1	REGISTRATION CONNECTOR INPUT VOLTAGE INSPECTION 1) Disconnect registration connector. 2) Measure voltage between keyless entry control module harness connector and chassis ground. <i>Connector & terminal</i> <i>(B176) No. 2 (+) — Chassis ground (-):</i>	Is the voltage more than 10 V?	Go to step 2.	Repair harness, and (or) connector.
2	REGISTRATION CONNECTOR INPUT VOLTAGE INSPECTION 1) Connect registration connector. 2) Measure voltage between keyless entry control module harness connector and chassis ground. <i>Connector & terminal</i> <i>(B176) No. 2 (+) — Chassis ground (-):</i>	Is the voltage 0 V?	Registration connector circuit is OK.	Repair harness, and (or) connector.

KEYLESS ENTRY SYSTEM

Security and Locks

6. CHECK DOOR SWITCH S909345A1007

No.	Step	Check	Yes	No
1	CHECK DOOR SWITCH CIRCUIT. Measure the voltage between the keyless entry control module harness connector terminal and chassis ground. Connector & terminal (B176) No. 3 (+) — Chassis ground (-):	Is the voltage 0 V when each door and rear gate is opened?	Go to step 2.	Go to step 3.
2	CHECK DOOR SWITCH CIRCUIT. Measure the voltage between the keyless entry control module harness connector terminal and chassis ground. Connector & terminal (B176) No. 3 (+) — chassis ground (-):	Is the voltage more than 10 V when each door and rear gate is closed?	The door switch is OK.	Go to step 3.
3	CHECK DOOR SWITCH. 1) Disconnect the door switch harness connector. 2) Check the continuity between the door switch terminal and chassis ground. Terminal Front LH No. 1 — Chassis ground: Front RH No. 1 — Chassis ground: Rear LH No. 1 — Chassis ground: Rear RH No. 1 — Chassis ground: Rear gate No. 1 — No. 2:	Does continuity exist when the door switch is pushed?	Replace the door switch.	Go to step 4.
4	CHECK DOOR SWITCH. Check continuity between the door switch terminal and chassis ground. Terminal Front LH No. 1 — Chassis ground: Front RH No. 1 — Chassis ground: Rear LH No. 1 — Chassis ground: Rear RH No. 1 — Chassis ground: Rear gate No. 1 — No. 2:	Does continuity exist when the door switch is released?	Check the harness for open circuits and shorts between the keyless entry control module and door switch.	Replace the door switch.

7. CHECK KEY WARNING SWITCH S909345A1008

No.	Step	Check	Yes	No
1	CHECK FUSE. Remove and visually check fuse No. 6 (in the main fuse box).	Is the fuse blown? (15A)	Replace the fuse with a new one.	Go to step 2.
2	CHECK KEY WARNING SWITCH CIRCUIT. 1) Disconnect the keyless entry control module harness connector. 2) Insert the key into the ignition switch. (LOCK position) 3) Measure the voltage between the harness connector terminal and chassis ground. Connector & terminal (B176) No. 1 (+) — chassis ground (-):	Is the voltage more than 10 V?	Go to step 3.	Go to step 4.
3	CHECK KEY WARNING SWITCH CIRCUIT. 1) Remove the key from the ignition switch. 2) Measure the voltage between the harness connector terminal and chassis ground. Connector & terminal (B176) No. 1 (+) — chassis ground (-):	Is the voltage 0 V?	The key warning switch is OK.	Go to step 4.

KEYLESS ENTRY SYSTEM

Security and Locks

No.	Step	Check	Yes	No
4	CHECK KEY WARNING SWITCH. 1) Disconnect the key warning switch harness connector. 2) Insert the key into the ignition switch. (LOCK position) 3) Check the continuity between the key warning switch terminals. Terminal No. 1 — No. 2:	Does continuity exist?	Go to step 5.	Replace key warning switch.
5	CHECK KEY WARNING SWITCH. 1) Remove the key from the ignition switch. 2) Check the continuity between the key warning switch terminals. Terminal No. 1 — No. 2:	Does continuity exist?	Replace key warning switch.	Check the following: <ul style="list-style-type: none"> ● Harness for open circuits or shorts between the key warning switch and fuse ● Harness for open circuits and shorts between the keyless entry control module and key warning switch

8. CHECK HAZARD LIGHT OPERATION

S909345A1013

No.	Step	Check	Yes	No
1	CHECK HAZARD LIGHT OPERATION. Make sure the hazard light blinks when hazard switch is turned ON.	Does hazard light blink?	Go to step 2.	Check hazard light circuit.
2	CHECK OUTPUT SIGNAL. 1) Remove the key from ignition switch. 2) Close all doors and rear gate. 3) Measure voltage between keyless entry control module harness connector terminal and chassis ground when LOCK or OPEN button of transmitter is pressed. Connector & terminal (B176) No. 12, No. 13 (+) — Chassis ground (-):	Is the voltage more than 10 V?	Check harness for open or short between keyless entry control module and turn signal lights.	Replace the keyless entry control module.

KEYLESS ENTRY SYSTEM

Security and Locks

9. CHECK ROOM LIGHT OPERATION

S909345A1010

No.	Step	Check	Yes	No
1	CHECK ROOM LIGHT OPERATION. Make sure the room light illuminates when the room light switch is turned ON.	Does the room light illuminate?	Go to step 2.	Check the room light circuit.
2	CHECK HARNESS BETWEEN ROOM LIGHT AND KEYLESS ENTRY CONTROL MODULE. 1) Disconnect the keyless entry control module harness connector and room light harness connector. 2) Measure the resistance between the keyless entry control module harness connector terminal and the room light harness connector terminal. Connector & terminal (B176) No. 11 — (R52) No. 2:	Is the resistance less than 10 Ω ?	The room light operation circuit is OK.	Check the harness for open circuits or shorts between the keyless entry control module and room light.

10. CHECK IGNITION SWITCH ILLUMINATION CIRCUIT

S909345A1014

No.	Step	Check	Yes	No
1	CHECK IGNITION SWITCH ILLUMINATION POWER SUPPLY. 1) Disconnect the ignition switch illumination harness connector. 2) Measure voltage between the ignition switch illumination harness connector terminal and chassis ground. Connector & terminal (B224) No. 1 (+) — Chassis ground (-):	Is the voltage more than 10 V?	Go to step 2.	Check harness for open circuit or shorts between the ignition switch illumination and fuse.
2	CHECK HARNESS BETWEEN IGNITION SWITCH ILLUMINATION AND KEYLESS ENTRY CONTROL MODULE. 1) Disconnect the keyless entry control module harness connector. 2) Measure the resistance between the keyless entry harness connector terminal and the ignition switch illumination harness connector. Connector & terminal (B176) No. 11 — (B224) No. 2:	Is the resistance less than 10 Ω ?	Check the ignition switch illumination. If NG, replace the ignition switch illumination.	Repair the harness.

4. Front Inner Remote S909344

A: REMOVAL S909344A18

- 1) Remove the door trim. <Ref. to EI-26 REMOVAL, Front Door Trim.>
- 2) Remove the sealing cover. <Ref. to EB-13 REMOVAL, Front Sealing Cover.>
- 3) Remove the two rod joints.
- 4) Unlatch rod holder
- 5) Remove the front inner remote.

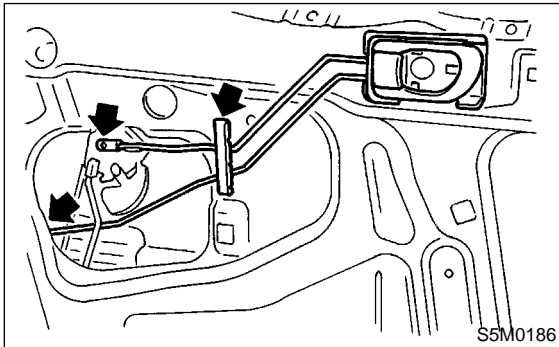

B: INSTALLATION S909344A11

Install in the reverse order of removal.

NOTE:

Make sure the inner remote works properly after installation.

C: INSPECTION S909344A10

- 1) Make sure the rod is not deformed.
- 2) Make sure the lever and rod work smoothly.

5. Front Outer Handle S909349

A: REMOVAL S909349A18

- 1) Remove the door trim. <Ref. to EI-26 REMOVAL, Front Door Trim.>
- 2) Remove the sealing cover. <Ref. to EB-13 REMOVAL, Front Sealing Cover.>
- 3) Remove the front inner remote. <Ref. to SL-27 REMOVAL, Front Inner Remote.>
- 4) Remove the two bolts. Remove the front outer handle (B).

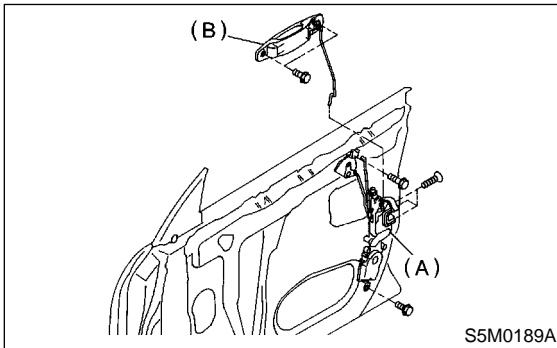

CAUTION:

Do not use excessive force to remove the door panel. This will deform it.

B: INSTALLATION S909349A11

Install in the reverse order of removal.

NOTE:

Make sure outer handle works properly after installation.

C: INSPECTION S909349A10

- 1) Make sure the rod is not deformed.
- 2) Make sure the lever and rod work smoothly.

6. Front Door Latch Assembly

S909334

A: REMOVAL S909334A18

- 1) Remove the front door trim. <Ref. to EI-26 REMOVAL, Front Door Trim.>
- 2) Remove the sealing cover. <Ref. to EB-13 REMOVAL, Front Sealing Cover.>
- 3) Remove the front inner remote. <Ref. to SL-27 REMOVAL, Front Inner Remote.>
- 4) Turn rod holder to disconnect joint between key lock and rod.
- 5) Turn rod holder to disconnect joint between outer handle and rod.
- 6) Turn rod holder to disconnect joint between crank and rod.
- 7) Remove the three screws and bolt.

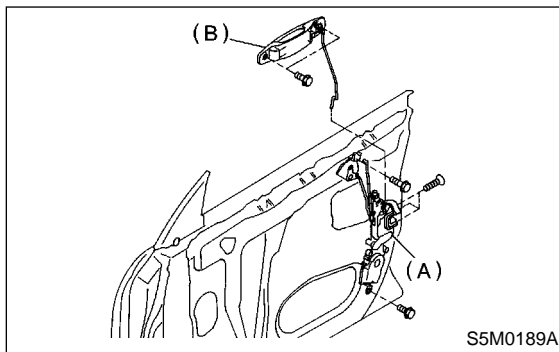

- 8) Disconnect the connector. Remove the front door latch assembly (A).

B: INSTALLATION S909334A11

Install in the reverse order of removal.

NOTE:

Make sure parts work properly after installation.

C: INSPECTION S909334A10

- 1) Make sure the rod is not deformed.
- 2) Make sure the lever and rod work smoothly.

FRONT DOOR LOCK ACTUATOR

Security and Locks

7. Front Door Lock Actuator S909319

A: REMOVAL S909319A18

- 1) Remove the front door latch assembly. <Ref. to SL-27 REMOVAL, Front Door Latch Assembly.>
- 2) Remove the bolt. Remove the front door lock actuator.

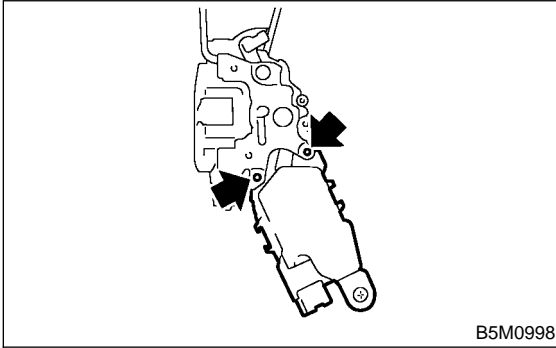

B: INSTALLATION S909319A11

Install in the reverse order of removal.

C: INSPECTION S909319A10

- 1) Disconnect the door lock actuator harness connector.
- 2) Connect the battery to the door lock actuator terminals.

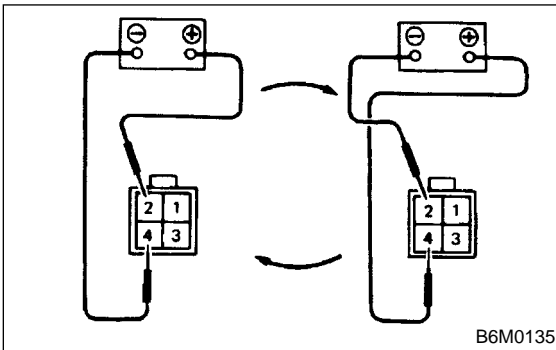

Battery connection	Actuator operation
No. 2 (+) — No. 4 (-)	Unlocked → Locked
No. 4 (+) — No. 2 (-)	Locked → Unlocked

If NG, replace the door lock actuator.

8. Rear Inner Remote S909321

A: REMOVAL S909321A18

- 1) Remove the rear door trim. <Ref. to EI-27 REMOVAL, Rear Door Trim.>
- 2) Remove the sealing cover. <Ref. to EB-16 REMOVAL, Rear Sealing Cover.>
- 3) Remove the two rod joints.
- 4) Remove the inner remote.

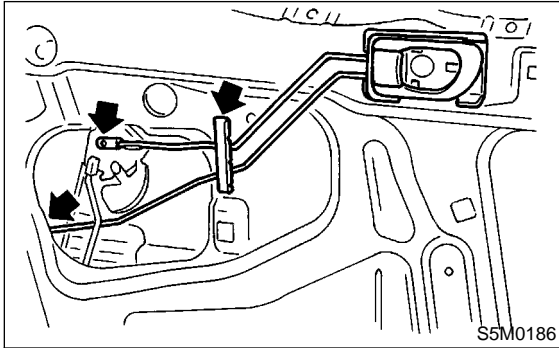

B: INSTALLATION S909321A11

Install in the reverse order of removal.

NOTE:

Make sure the inner remote works properly after installation.

C: INSPECTION S909321A10

- 1) Make sure the rod is not deformed.
- 2) Make sure the lever and rod work smoothly.
- 3) Make sure the child safety lock on rear doors work properly, when applicable.

9. Rear Outer Handle S909322

A: REMOVAL S909322A18

- 1) Remove the rear door trim. <Ref. to EI-27 REMOVAL, Rear Door Trim.>
- 2) Remove the sealing cover. <Ref. to EB-16 REMOVAL, Rear Sealing Cover.>
- 3) Remove the rear inner remote. <Ref. to SL-31 REMOVAL, Rear Inner Remote.>
- 4) Remove the rear door latch assembly. <Ref. to SL-33 REMOVAL, Rear Door Latch Assembly.>
- 5) Remove the two bolts and nut. Remove the rear outer handle.

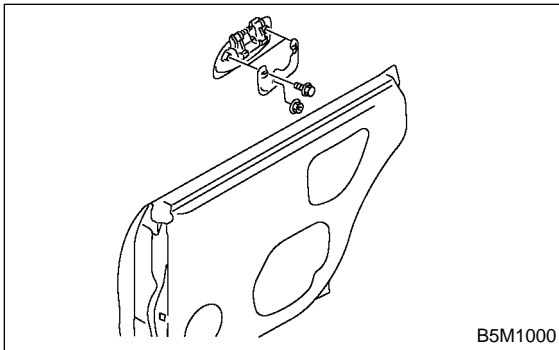

CAUTION:

Do not use excessive force to remove the door panel. This will deform it.

B: INSTALLATION S909322A11

Install in the reverse order of removal.

NOTE:

Make sure the outer handle works properly after installation.

C: INSPECTION S909322A10

- 1) Make sure the rod is not deformed.
- 2) Make sure the lever and rod work smoothly.

10. Rear Door Latch Assembly

S909320

A: REMOVAL S909320A18

- 1) Remove the rear door trim. <Ref. to EI-27 REMOVAL, Rear Door Trim.>
- 2) Remove the sealing cover. <Ref. to EB-16 REMOVAL, Rear Sealing Cover.>
- 3) Remove the rear inner remote. <Ref. to SL-31 REMOVAL, Rear Inner Remote.>
- 4) Remove the three screws and bolt.

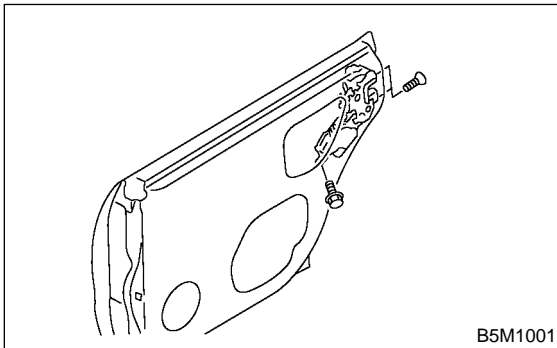

- 5) Disconnect the connector. Remove the rear door latch assembly.

B: INSTALLATION S909320A11

Install in the reverse order of removal.

NOTE:

Make sure parts work properly after installation.

C: INSPECTION S909320A10

- 1) Make sure the rod is not deformed.
- 2) Make sure the lever and rod work smoothly.

11. Rear Door Lock Actuator S909323

A: REMOVAL S909323A18

- 1) Remove the rear door latch assembly. <Ref. to SL-33 REMOVAL, Rear Door Latch Assembly.>
- 2) Remove the bolt. Remove the rear door lock actuator.

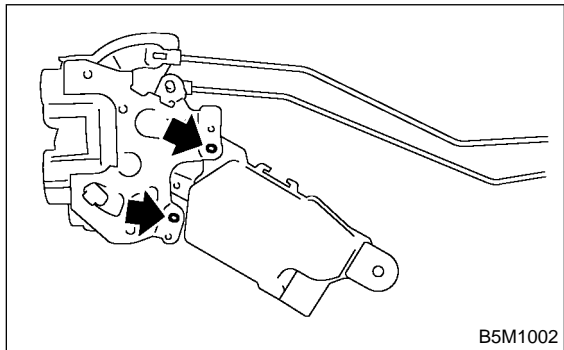

B: INSTALLATION S909323A11

Install in the reverse order of removal.

NOTE:

Make sure the lock works properly after installation.

C: INSPECTION S909323A10

- 1) Disconnect the door lock actuator harness connector.
- 2) Connect the battery to the door lock actuator terminals.

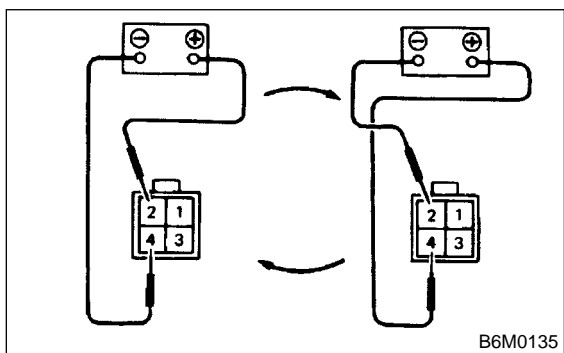

Battery connection	Actuator operation
No. 2 (+) — No. 4 (-)	Unlocked → Locked
No. 4 (+) — No. 2 (-)	Locked → Unlocked

If NG, replace the door lock actuator.

12. Rear Gate Outer Handle S909626

A: REMOVAL S909626A18

- 1) Remove the rear gate lower trim. <Ref. to 42 REMOVAL, Rear Gate Trim.>
- 2) Disconnect rod (latch to outer handle) from outer handle (B).
- 3) Remove the four nuts used to hold outer handle (B) to the inside of rear gate and detach outer handle.

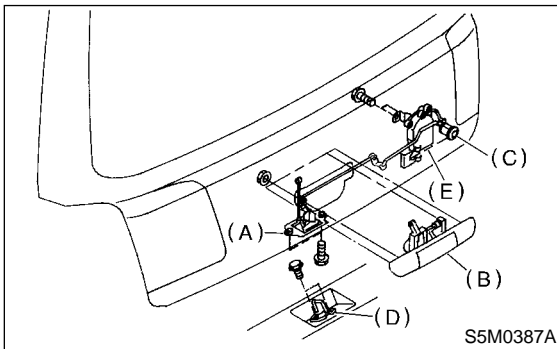

B: INSTALLATION S909626A11

Install in the reverse order of removal.

NOTE:

Make sure the outer handle works properly after installation.

C: INSPECTION S909626A10

- 1) Inspect the rod for deformation.
- 2) Make sure the lever and rod move smoothly.

13. Rear Gate Latch Assembly

S909316

A: REMOVAL S909316A18

- 1) Remove the rear gate lower trim. <Ref. to EI-42 REMOVAL, Rear Gate Trim.>
- 2) Disconnect rod (latch to link) from latch (A).
- 3) Disconnect rod (latch to outer handle) from outer handle (B).
- 4) Remove bolts from latch (A).

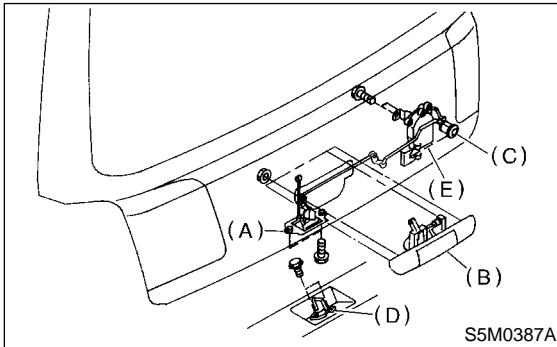

- 5) Disconnect rear gate switch connector from latch (A) and then detach the latch.

B: INSTALLATION S909316A11

Install in the reverse order of removal.

NOTE:

Make sure parts work properly after installation.

C: INSPECTION S909316A10

- 1) Make sure the rod is not deformed.
- 2) Make sure the lever and rod work smoothly.

14. Rear Gate Latch Lock Actuator

S909313

A: REMOVAL S909313A18

- 1) Remove rear gate trim. <Ref. to EI-42 REMOVAL, Rear Gate Trim.>
- 2) Disconnect rod from key cylinder.
- 3) Loosen two bolts to remove rear gate actuator (E).

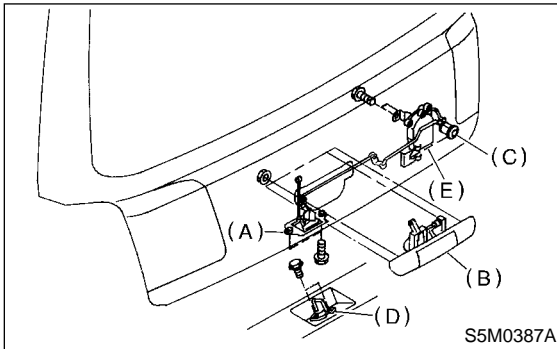

B: INSTALLATION S909313A11

Install in the reverse order of removal.

NOTE:

Make sure the lock works properly after installation.

C: INSPECTION S909313A10

- 1) Disconnect the door lock actuator harness connector.
- 2) Connect the battery to the door lock actuator terminals.

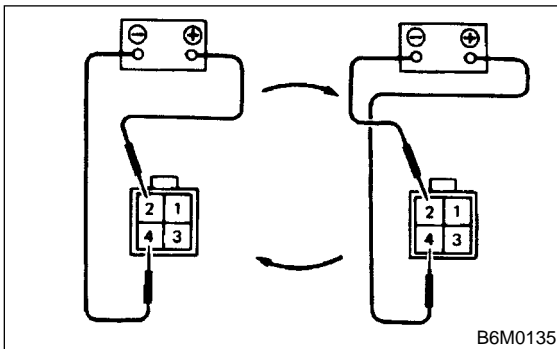

Battery connection	Actuator operation
No. 2 (+) — No. 4 (-)	Unlocked → Locked
No. 4 (+) — No. 2 (-)	Locked → Unlocked

If NG, replace the rear gate latch lock actuator.

15. Front Hood Lock Assembly

S909595

A: REMOVAL S909595A18

- 1) Open the hood.
- 2) Remove the bolt. Remove the hood lock assembly.
- 3) Remove the release cable from the lock assembly.

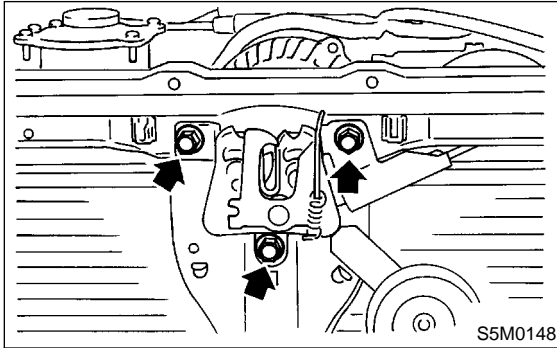

B: INSTALLATION S909595A11

Install in the reverse order of removal.

CAUTION:

- Apply grease to parts that rub.
- Make sure the release cable works properly after installation.

C: ADJUSTMENT S909595A01

Loosen the bolt. Adjust the lock assembly while moving it up and down.

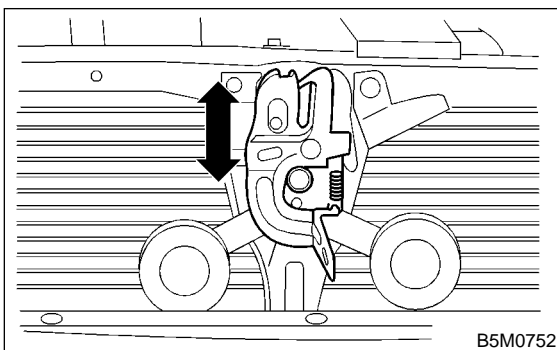

D: INSPECTION S909595A10

- 1) Check the striker for bending or abnormal wear.
- 2) Check the safety lever for improper movement.
- 3) Check other levers and the spring for rust formation and unsmooth movement.

16. Remote Openers S909317

A: REMOVAL S909317A18

1. HOOD OPENER S909317A1801

- 1) Remove the release cable from the hood lock.
- 2) Remove the bolt. Remove the opener lever.

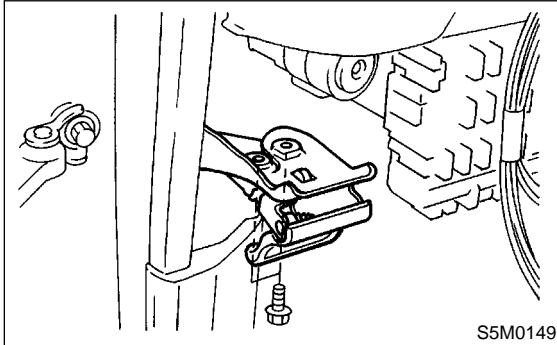

2. FUEL FLAP OPENER S909317A1803

- 1) Remove the rear seat. <Ref. to SE-6 REMOVAL, Rear Seat.>
- 2) Remove the center pillar lower trim and side sill cover on the passenger side. Remove the rear pillar lower trim. Pull back the floor mat. Remove the clip holding the cable.
- 3) Remove the bolt. Remove the opener pull handle.

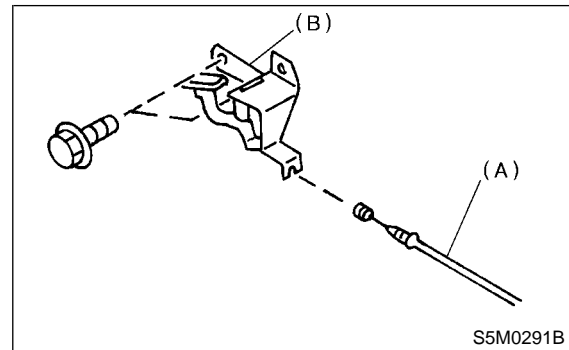

- 4) Remove the cable from the opener pull handle.
- 5) Remove the right rear quarter trim. <Ref. to EI-39 REMOVAL, Rear Quarter Trim.>
- 6) Rotate the fuel lock inside the quarter panel to left and remove.

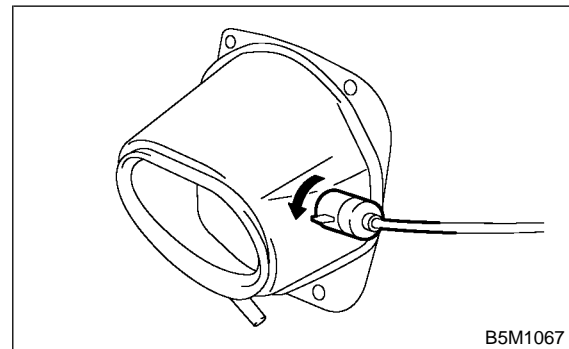

B: INSTALLATION S909317A11

1. HOOD OPENER S909317A1101

Install in the reverse order of removal.

2. FUEL FLAP OPENER S909317A1103

Install in the reverse order of removal.

C: INSPECTION S909317A10

Make sure the fuel flap opens and closes smoothly.

17. Ignition Key Lock S909318

A: REPLACEMENT S909318A20

- 1) Remove the battery ground cable.
- 2) Remove the steering column. <Ref. to DS-30 REMOVAL, Steering Column.>
- 3) Secure the steering column in a vise. Remove the bolt with a drill.

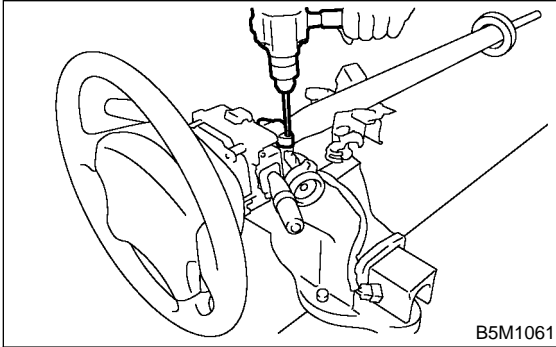

- 4) Remove the ignition key lock.
- 5) Use a new torn bolt. Tighten the torn bolt to the end of the thread.

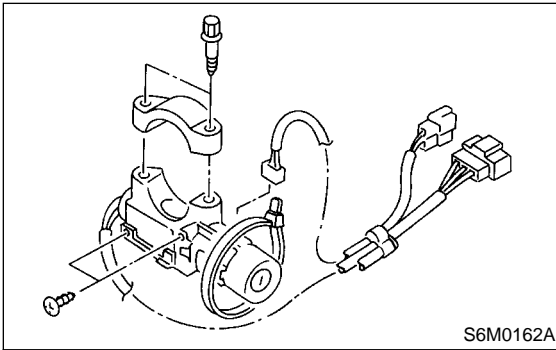

B: INSPECTION S909318A10

- 1) Remove the instrument panel lower cover.
- 2) Remove the lower column cover.
- 3) Unfasten the holddown clip which secures the harness and disconnect the connector of the ignition switch from the body harness.
- 4) Turn the ignition key plate to each position and check the continuity between the terminals of the ignition connector.

Switch position	Tester connection	Specified condition
LOCK		
ACC	No. 1 — No. 2	Continuity
ON	No. 1 — No. 2 — No. 4	Continuity
ST	No. 1 — No. 3 — No. 4	Continuity

If NG, replace the ignition switch.

18. Key Lock Cylinders S909326

A: REPLACEMENT S909326A20

1. FRONT DOOR S909326A2001

- 1) Remove the door trim. <Ref. to EI-26 REMOVAL, Front Door Trim.>
- 2) Pull back the sealing cover.
- 3) Remove the rod clamp. Remove the lock plate. Replace the key cylinder.

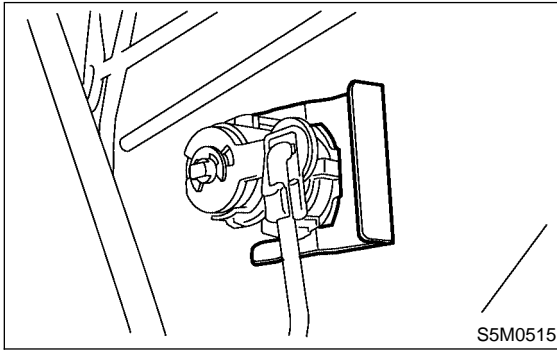

2. REAR GATE S909326A2003

- 1) Remove the rear gate lower trim. <Ref. to EI-42 REMOVAL, Rear Gate Trim.>
- 2) Remove the rod clamp. Remove the lock plate. Replace the key cylinder (C).

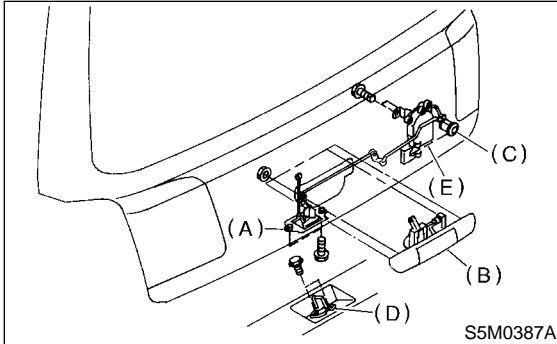

19. Immobilizer Control Module

S909315

A: REMOVAL S909315A18

NOTE:

The following positions for removal and installation are for LHD models. The positions for RHD models are symmetrically opposite.

- 1) Disconnect GND cable from battery.
- 2) Remove instrument panel lower cover. <Ref. to EI-31 REMOVAL, Instrument Panel Assembly.>
- 3) Disconnect connector from immobilizer control module.
- 4) Remove immobilizer control module.

DOHC Turbo and SOHC with OBD model:

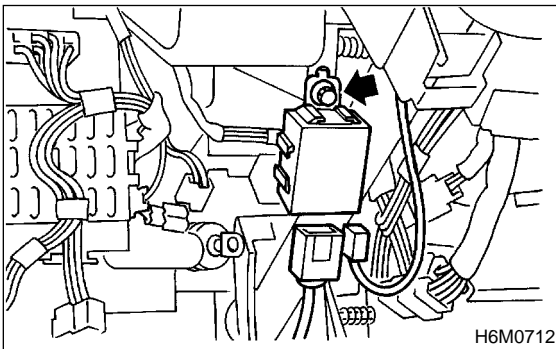

SOHC without OBD model:

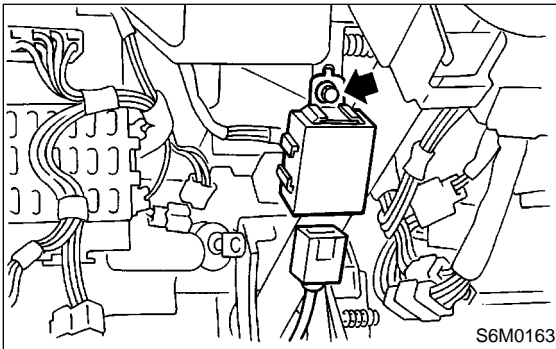

B: INSTALLATION S909315A11

Install in the reverse order of removal.

20. Immobilizer Antenna S909331

A: REMOVAL S909331A18

- 1) Disconnect GND cable from battery.
- 2) Remove instrument panel lower cover. <Ref. to EI-31 REMOVAL, Instrument Panel Assembly.>
- 3) Remove screws, separate upper column cover and lower column cover.

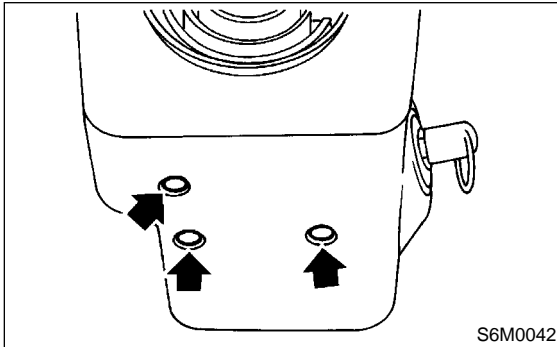

- 4) Disconnect immobilizer antenna connector (A) from immobilizer control module.
- 5) Remove immobilizer antenna (B).

DOHC Turbo and SOHC with OBD model:

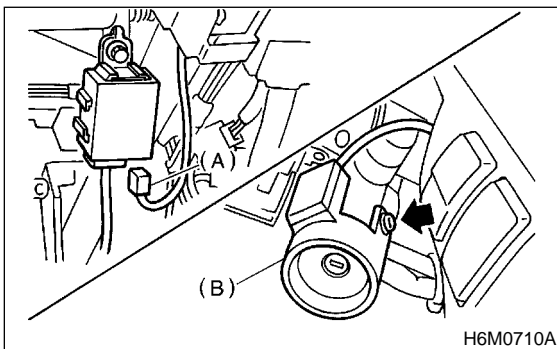

SOHC without OBD model:

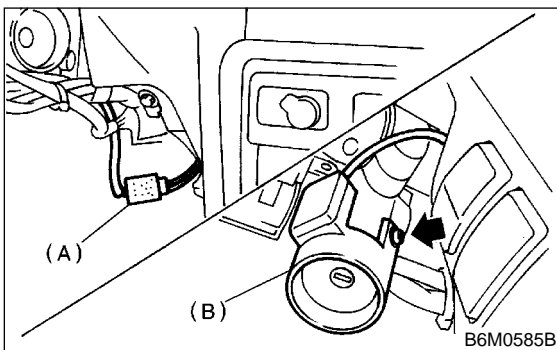

B: INSTALLATION S909331A11

Install in the reverse order of removal.

21. Keyless Entry Control Module

S909324

A: REMOVAL

S909324A18

- 1) Disconnect battery ground cable.
- 2) Remove instrument panel lower cover. <Ref. to EI-31 REMOVAL, Instrument Panel Assembly.>
- 3) Remove nut, then remove keyless entry control module (A) while disconnecting connector.

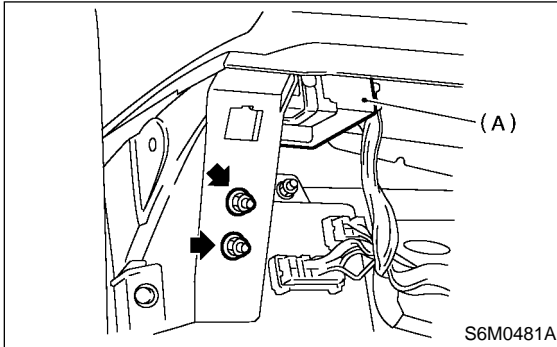

- 4) Disconnect keyless entry control module.

B: INSTALLATION

S909324A11

Install in the reverse order of removal.

22. Keyless Transmitter S909325

A: REMOVAL S909325A18

1. TRANSMITTER BATTERY S909325A1801

Remove battery from transmitter.

NOTE:

To prevent static electricity damage to transmitter printed circuit board, touch steel area of building with hand to discharge static electricity carried on body or clothes before disassembling transmitter.

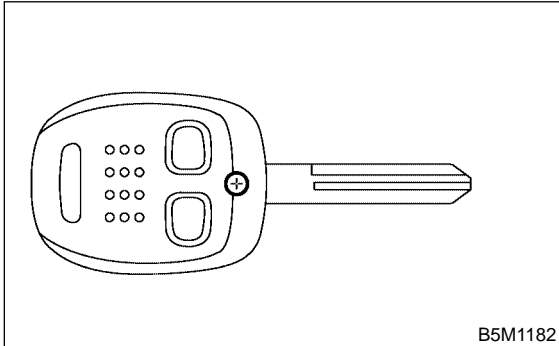

B: INSTALLATION S909325A11

1. TRANSMITTER BATTERY S909325A1101

Install in the reverse order of removal.

C: INSPECTION S909325A10

1. TRANSMITTER BATTERY S909325A1001

1) Measure voltage between battery (+) terminal and (-) terminal.

NOTE:

- Battery discharge occurs during measurement. Complete measurement within 5 seconds.
- During battery voltage measurement, voltage falls more than 1.8 volts in 3 seconds period.

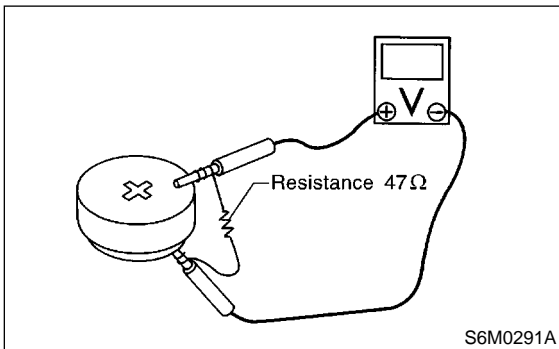

If NG, replace the battery. (Use CR1620 or equivalent.)

D: REPLACEMENT S909325A20

1. TRANSMITTER REGISTRATION S909325A2001

NOTE:

A maximum of 3 transmitters can be registered for each individual vehicle.

- 1) Remove the side sill cover at the driver's side, then connect the registration connectors at the front pillar lower section.
- 2) Unlock the door lock.
- 3) Press any button of the transmitter twice to be registered.
- 4) The door lock will automatically lock and unlock in sequence. This indicates the completion of transmitter registration for the first transmitter.
- 5) If registration of a second transmitter is now to be carried out, press any button of that transmitter twice.
- 6) The door lock will automatically lock and unlock in sequence. This indicates the completion of transmitter registration for the second transmitter.
- 7) If registration of third transmitter is now to be carried out, repeat procedure of step 5) and 6).
- 8) Disconnect the registration connectors after the completion of all registration operations. After confirming the operation of the door lock using the newly registered transmitter(s), reinstall the side sill cover at the driver's side.

Tester connection		Voltage (V)
(+)	(-)	
Battery (+) terminal	Battery (-) terminal	More than 2

KEYLESS TRANSMITTER

Security and Locks

MEMO: