

**BODY SECTION**

This service manual has been prepared to provide SUBARU service personnel with the necessary information and data for the correct maintenance and repair of SUBARU vehicles.

This manual includes the procedures for maintenance, disassembling, reassembling, inspection and adjustment of components and diagnostics for guidance of experienced mechanics.

Please peruse and utilize this manual fully to ensure complete repair work for satisfying our customers by keeping their vehicle in optimum condition. When replacement of parts during repair work is needed, be sure to use SUBARU genuine parts.

All information, illustration and specifications contained in this manual are based on the latest product information available at the time of publication approval.

FUJI HEAVY INDUSTRIES LTD.

**HVAC SYSTEM  
(HEATER, VENTILATOR AND A/C) AC**

**AIRBAG SYSTEM AB**

**SEAT BELT SYSTEM SB**

**LIGHTING SYSTEM LI**

**WIPER AND WASHER SYSTEMS WW**

**ENTERTAINMENT ET**

**COMMUNICATION SYSTEM COM**

**GLASS/WINDOWS/MIRRORS GW**

**BODY STRUCTURE BS**

**INSTRUMENTATION/DRIVER INFO IDI**

**SEATS SE**

**SECURITY AND LOCKS SL**

**SUNROOF/T-TOP/CONVERTIBLE TOP  
(SUNROOF) SR**

**EXTERIOR/INTERIOR TRIM EI**

**EXTERIOR BODY PANELS EB**

**CRUISE CONTROL SYSTEM CC**

# IMMOBILIZER (DIAGNOSTICS)

***IM***

---

	<b>Page</b>
1. Basic Diagnostic Procedure .....	2
2. General Description.....	3
3. Electrical Components Location.....	5
4. Immobilizer Control Module I/O Signal .....	6
5. Subaru Select Monitor.....	14
6. Read Diagnostic Trouble Code .....	16
7. Clear Memory Mode.....	18
8. Diagnostics Chart for Immobilizer Indicator Light .....	19
9. List of Diagnostic Trouble Code .....	25
10. Diagnostics Chart with Trouble Code .....	26

# BASIC DIAGNOSTIC PROCEDURE

Immobilizer (Diagnostics)

## 1. Basic Diagnostic Procedure

S009501

### A: PROCEDURE S009501E45

No.	Step	Check	Yes	No
1	<b>CHECK ILLUMINATION OF IMMOBILIZER INDICATOR LIGHT.</b> Turn ignition switch ON.	Does immobilizer indicator light illuminate?	Go to step 2.	Go to step 3.
2	<b>CHECK ENGINE START.</b> Turn ignition switch to START position.	Is the engine hard to start?	Go to step 5.	Go to step 3.
3	<b>CHECK ILLUMINATION OF IMMOBILIZER INDICATOR LIGHT.</b> 1) Turn ignition switch to OFF or ACC position. 2) Wait at least 60 seconds.	Does immobilizer indicator light blink?	Go to step 4.	Check immobilizer indicator light circuit. <Ref. to IM-19, CHECK IMMOBILIZER INDICATOR CIRCUIT, INSPECTION, Diagnostics Chart for Immobilizer Indicator Light.>
4	<b>CHECK ILLUMINATION OF IMMOBILIZER INDICATOR LIGHT.</b> Remove key from ignition switch.	Does immobilizer indicator light begin to blink 5 seconds after the key is removed?	The immobilizer system is OK.	Check key switch circuit. <Ref. to IM-22, CHECK KEY SWITCH CIRCUIT, INSPECTION, Diagnostics Chart for Immobilizer Indicator Light.>
5	<b>CHECK INDICATION OF DTC ON DISPLAY.</b> 1) Turn ignition switch OFF. 2) Connect the Subaru Select Monitor to data link connector. <Ref. to IM-14, OPERATION, Subaru Select Monitor.> 3) Turn ignition switch and Subaru Select Monitor switch ON. 4) Read DTC on the display.	Is trouble code indicated on display?	Go to step 6.	Repair the related parts.
6	<b>PERFORM THE DIAGNOSIS.</b> 1) Inspect using "Diagnostics Chart with Trouble Code". <Ref. to IM-26, Diagnostics Chart with Trouble Code.> 2) Repair the trouble cause. 3) Perform clear memory mode. 4) Read DTC again.	Is trouble code indicated on display?	Inspect using "Diagnostic Chart with Trouble Code". <Ref. to IM-26, Diagnostics Chart with Trouble Code.>	Finish the diagnostics.

**2. General Description** S009001

**A: CAUTION** S009001A03

**CAUTION:**

- Airbag system wiring harness is routed near the immobilizer control module. All airbag system wiring harness and connectors are colored yellow. Do not use electrical test equipment on these circuits.
- Be careful not to damage airbag system wiring harness when servicing the immobilizer control module.
- While diagnostic items are being checked, do not operate radios, portable telephones, etc. which emit electromagnetic waves near or inside the vehicle.

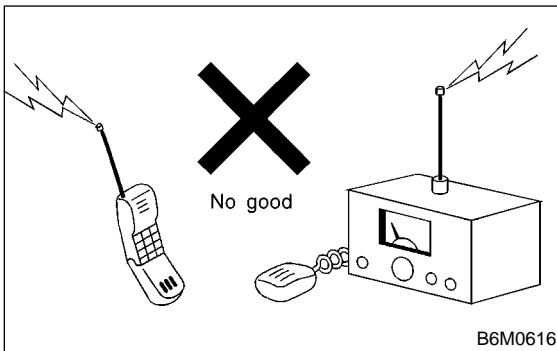

- When ignition switch is being turned ON or OFF while diagnostic items are being checked, do not allow keys with different ID codes close to the ignition switch. If ignition key is in a key holder, remove it from holder before carrying out diagnoses.

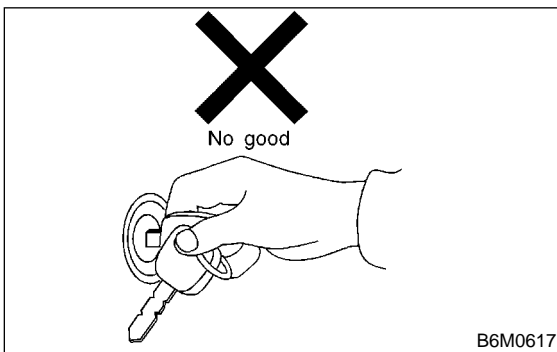

- When repeatedly turning ignition ON or OFF while diagnostic items are being checked, it should be switched in cycles of "ON" for at least 5 seconds → "OFF" for at least 8 seconds.

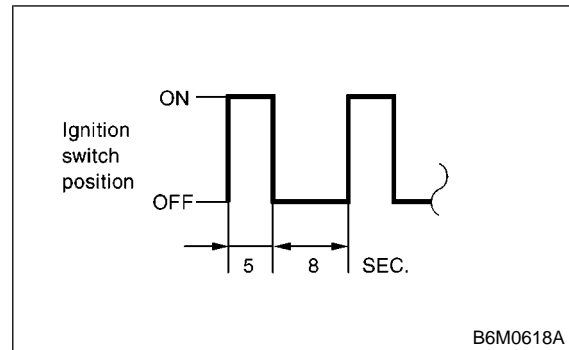



- If engine fails to start with a registered ignition key, detach ignition key from ignition switch and wait for approximately 1 second until immobilizer indicator light begins to flash. Start engine again.
- Before checking diagnostic items, obtain all keys for vehicle to be checked possessed by owner.

# GENERAL DESCRIPTION

Immobilizer (Diagnostics)

## B: PREPARATION TOOL S009001A17

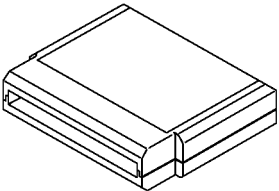
### 1. SPECIAL TOOLS S009001A1701

ILLUSTRATION	TOOL NUMBER	DESCRIPTION	REMARKS
 <small>B2M3876</small>	24082AA150 (Newly adopted tool)	CARTRIDGE	Troubleshooting for electrical systems.
 <small>B2M3877</small>	22771AA030	SELECT MONITOR KIT	Troubleshooting for electrical systems. <ul style="list-style-type: none"> <li>● English: 22771AA030 (Without printer)</li> <li>● German: 22771AA070 (Without printer)</li> <li>● French: 22771AA080 (Without printer)</li> <li>● Spanish: 22771AA090 (Without printer)</li> </ul>

### 2. GENERAL TOOLS S009001A1702

TOOL NAME	REMARKS
Circuit Tester	Used for measuring resistance, voltage and ampere.

### 3. Electrical Components Location

S009507

#### A: LOCATION

S009507A13

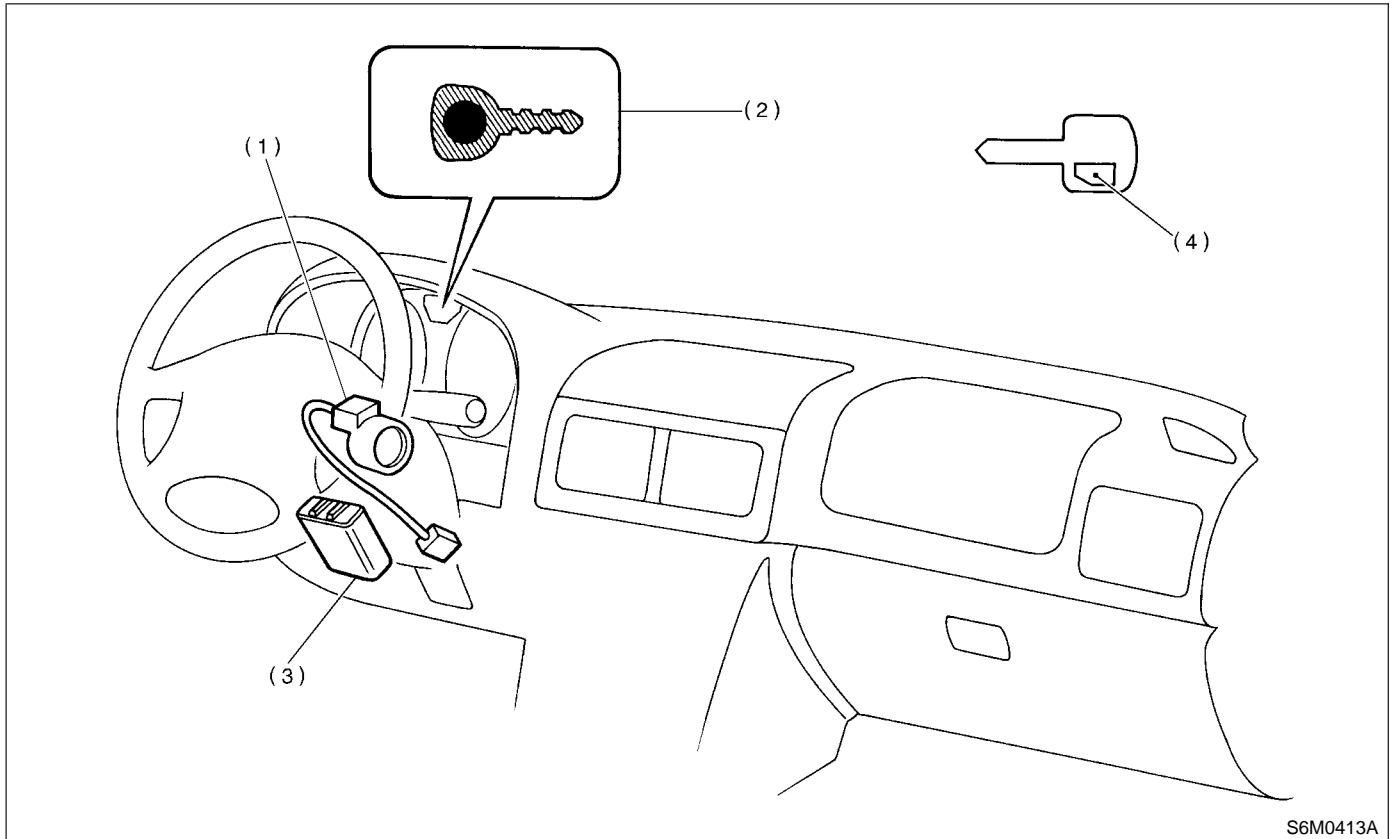

S6M0413A

- |  |  |
|--|--|
| (1) Antenna                                | (3) Immobilizer control module (IMM ECM) |
| (2) Immobilizer indicator light (LED bulb) | (4) Transponder                          |

NOTE:  
IMM ECM location for RHD model is symmetrically opposite.

# IMMOBILIZER CONTROL MODULE I/O SIGNAL

Immobilizer (Diagnostics)

## 4. Immobilizer Control Module I/O Signal S009517

### A: SCHEMATIC S009517A21

#### 1. IMMOBILIZER LHD WITH OBD MODEL S009517A2103

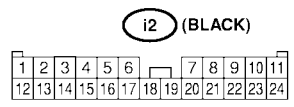
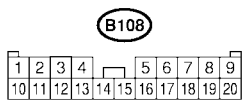
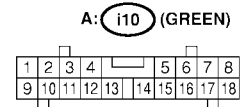
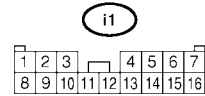
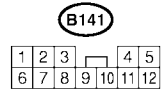
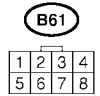
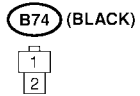
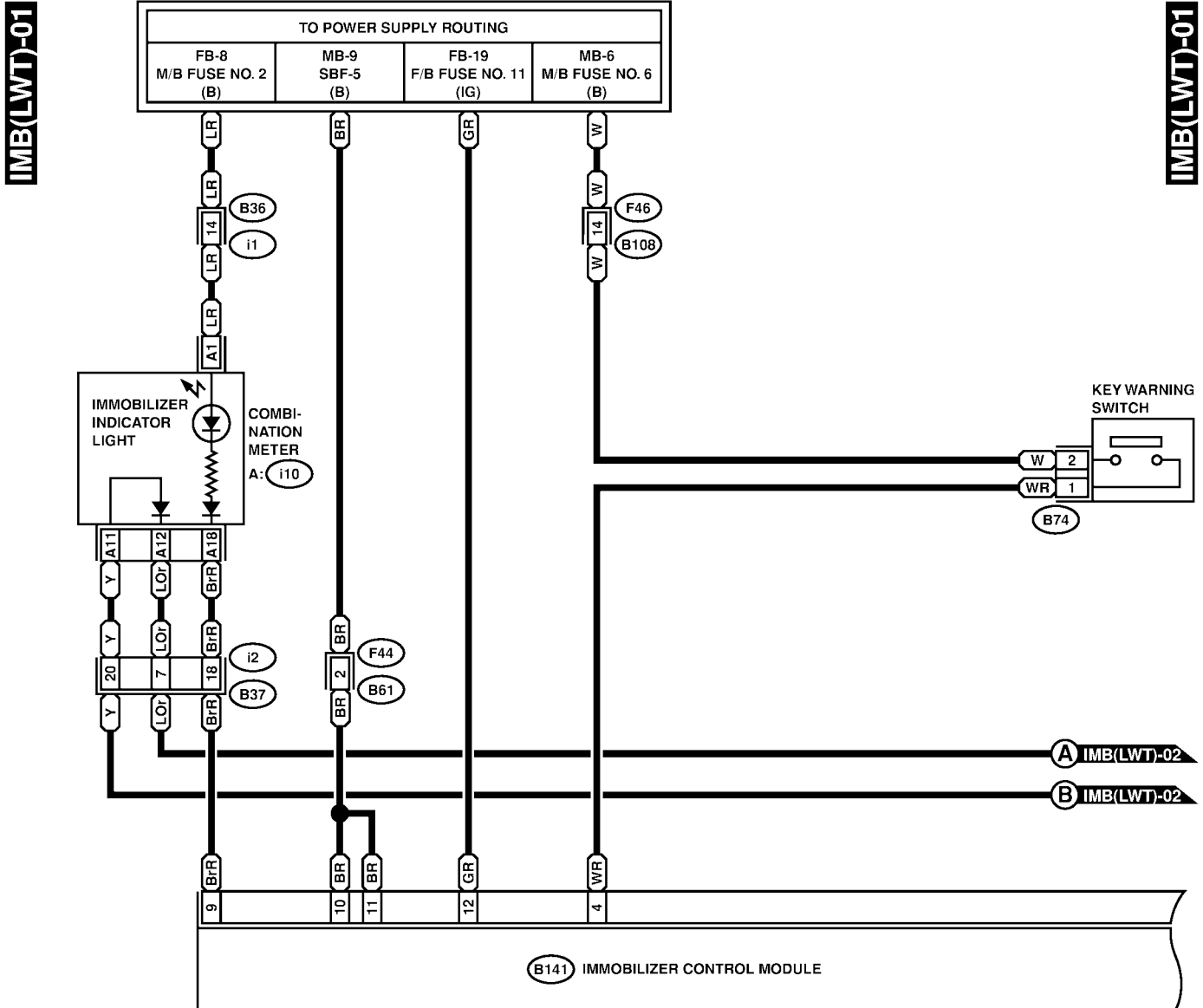

# IMMOBILIZER CONTROL MODULE I/O SIGNAL

Immobilizer (Diagnostics)

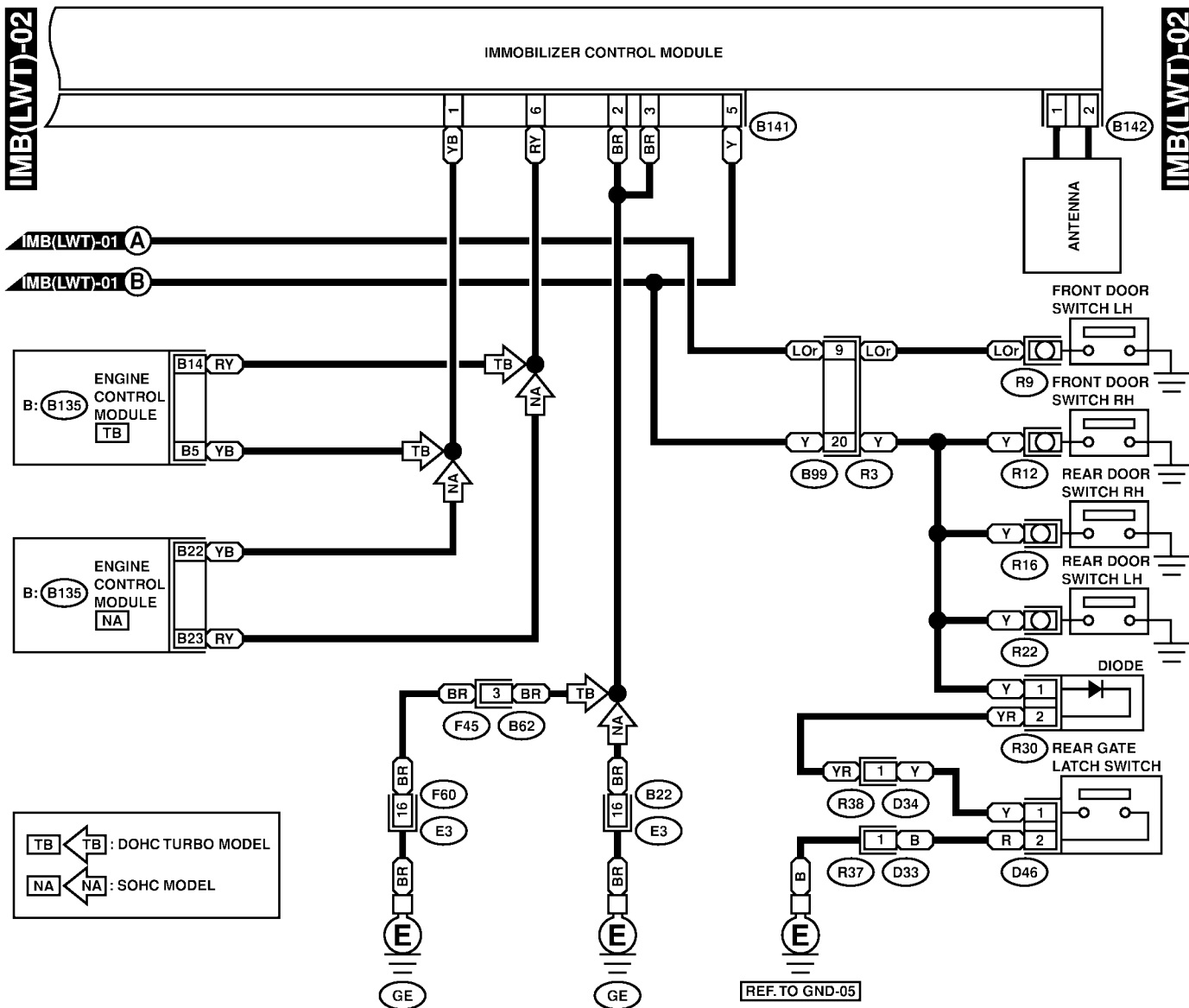

**B142**



**D33**



**D46 (BLACK)**



**R30**



**D34**



**B141**

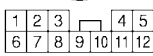

**F60 (BROWN)**

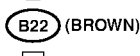

**B: (B135): NA**



**B: (B135): TB**



**B62**



**B99**

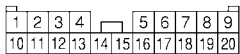



# IMMOBILIZER CONTROL MODULE I/O SIGNAL

Immobilizer (Diagnostics)

## 2. IMMOBILIZER LHD WITHOUT OBD MODEL

MODEL S009517A2104

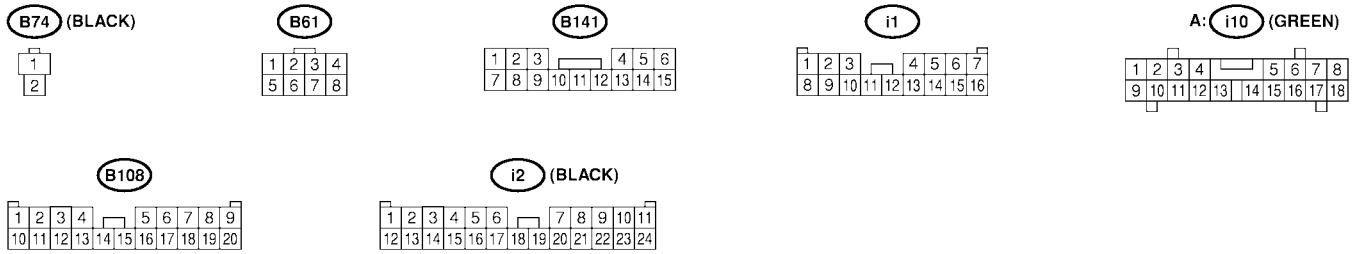
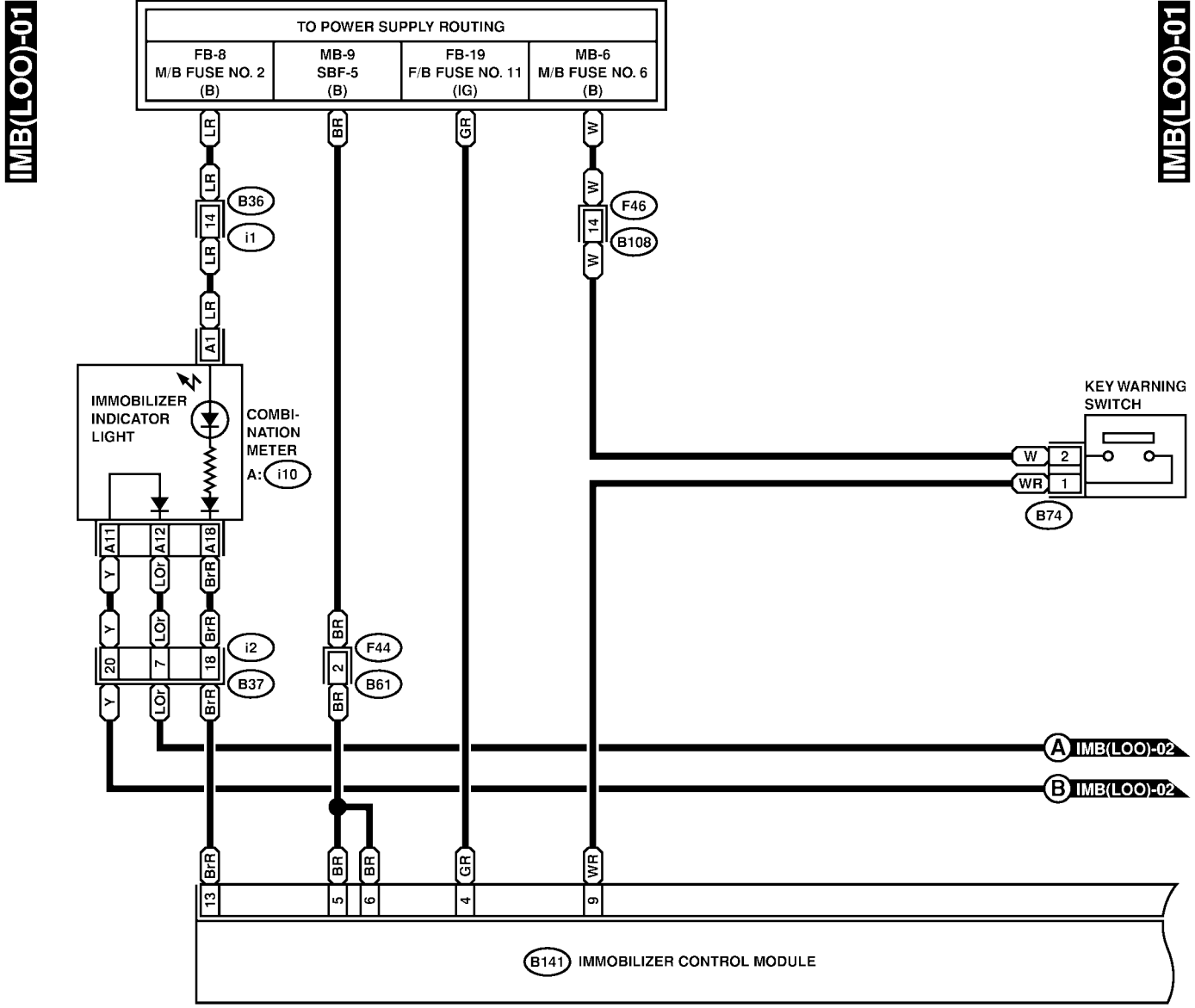

# IMMOBILIZER CONTROL MODULE I/O SIGNAL

Immobilizer (Diagnostics)

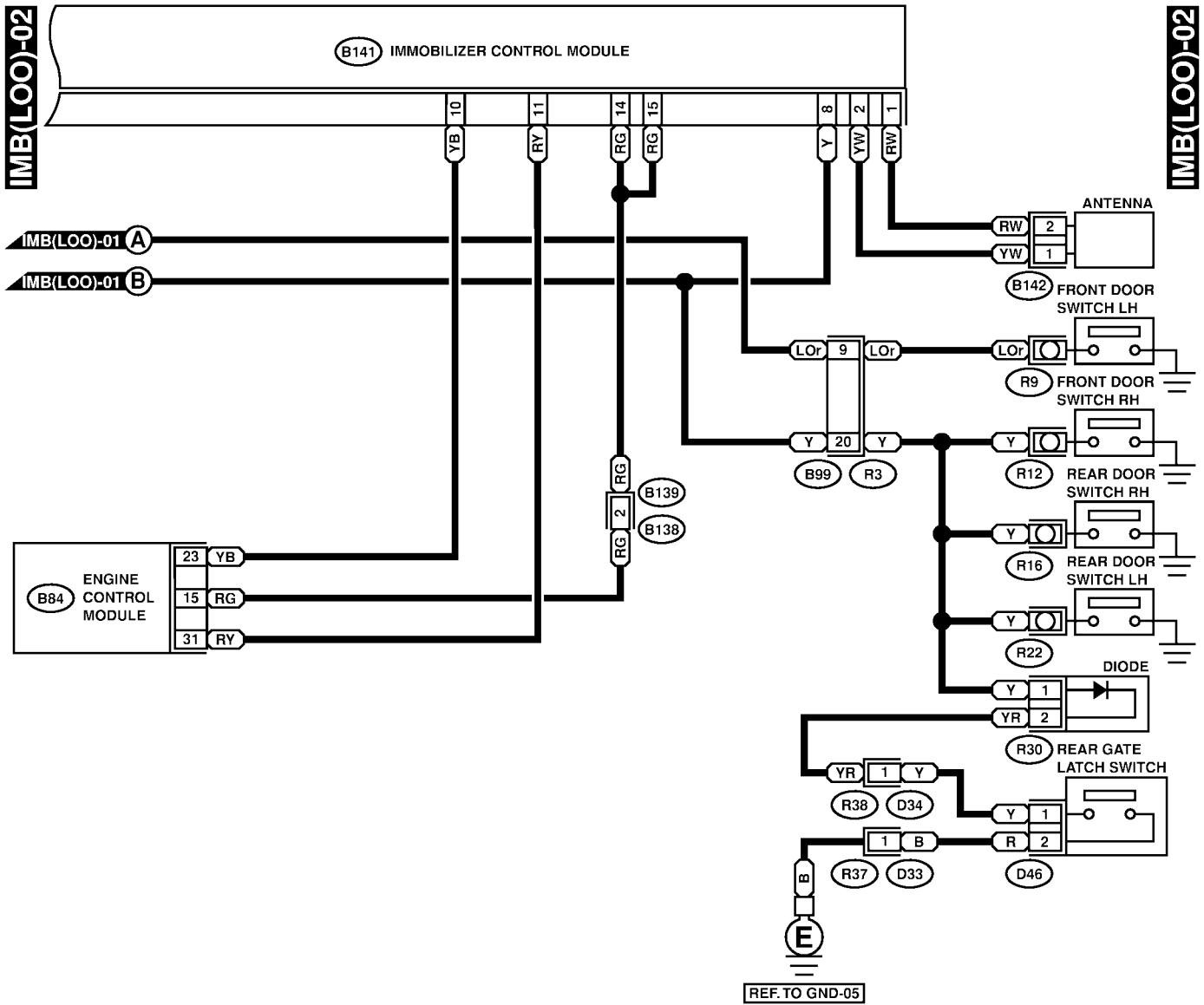

**B138**



**B142**



**D33**



**D46 (BLACK)**



**R30**



**D34**



**B141**

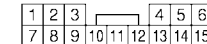

**B99**



**B84**

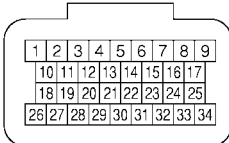

# IMMOBILIZER CONTROL MODULE I/O SIGNAL

Immobilizer (Diagnostics)

## 3. IMMOBILIZER RHD WITH OBD MODEL

S009517A2105

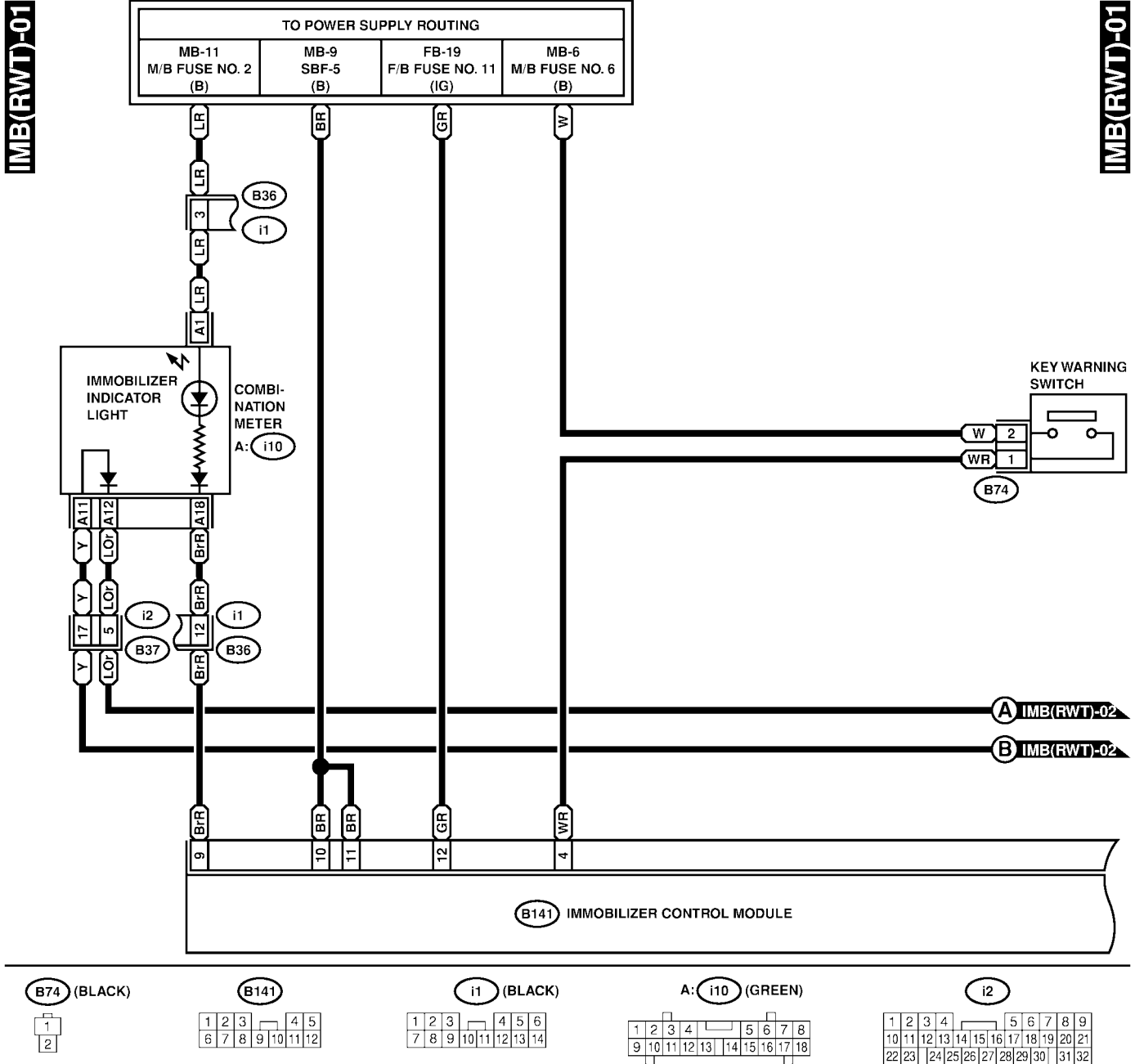

# IMMOBILIZER CONTROL MODULE I/O SIGNAL

Immobilizer (Diagnostics)

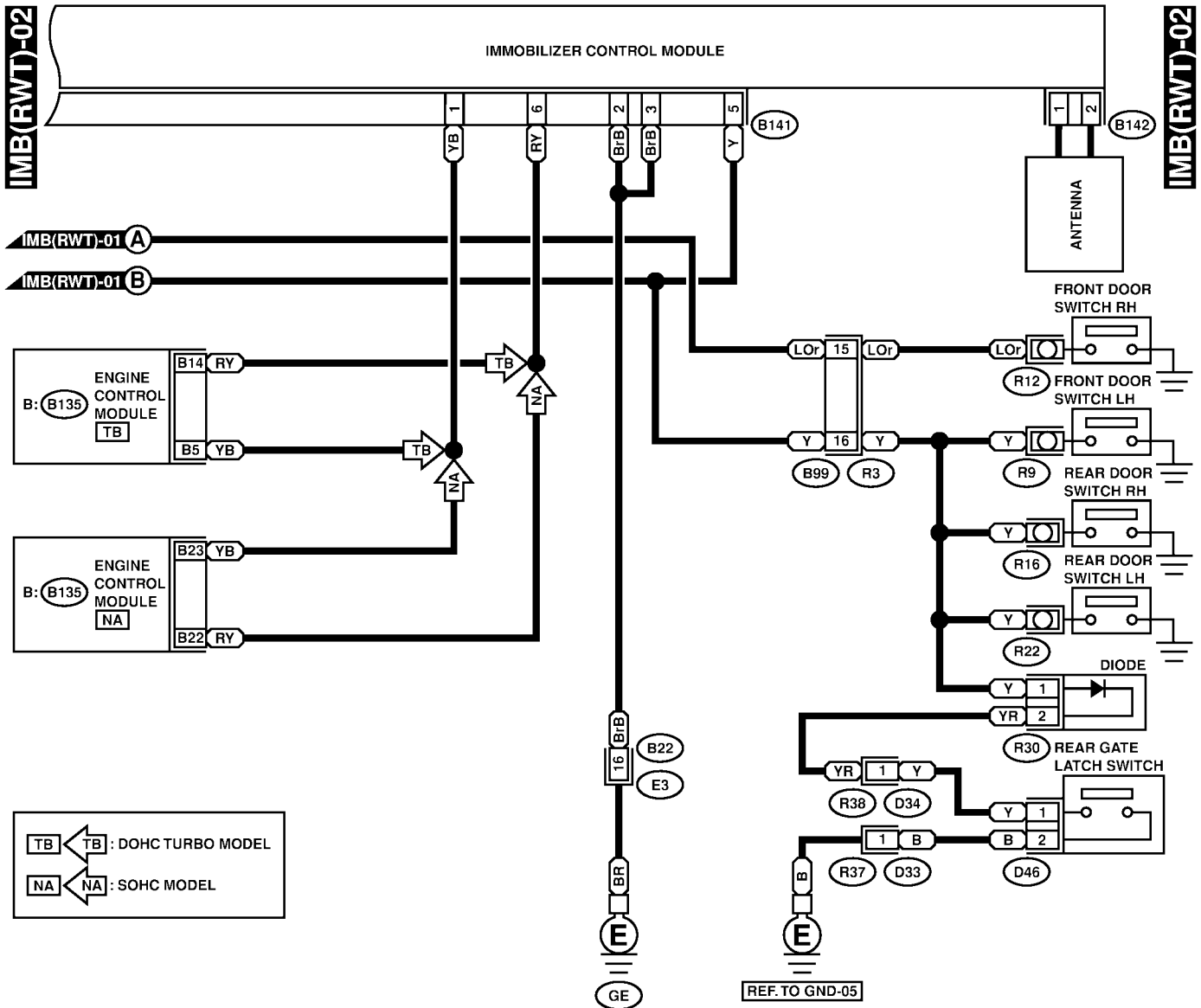

**B142**



**D33**



**D46 (BLACK)**



**R30**



**D34**



**B141**

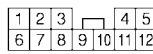

**B22 (BROWN)**



**B99 (BLUE)**

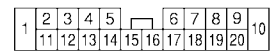

**B: (B135): NA**

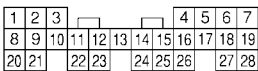

**B: (B135): TB**



# IMMOBILIZER CONTROL MODULE I/O SIGNAL

Immobilizer (Diagnostics)

## 4. IMMOBILIZER RHD WITHOUT OBD

MODEL S009517A2106

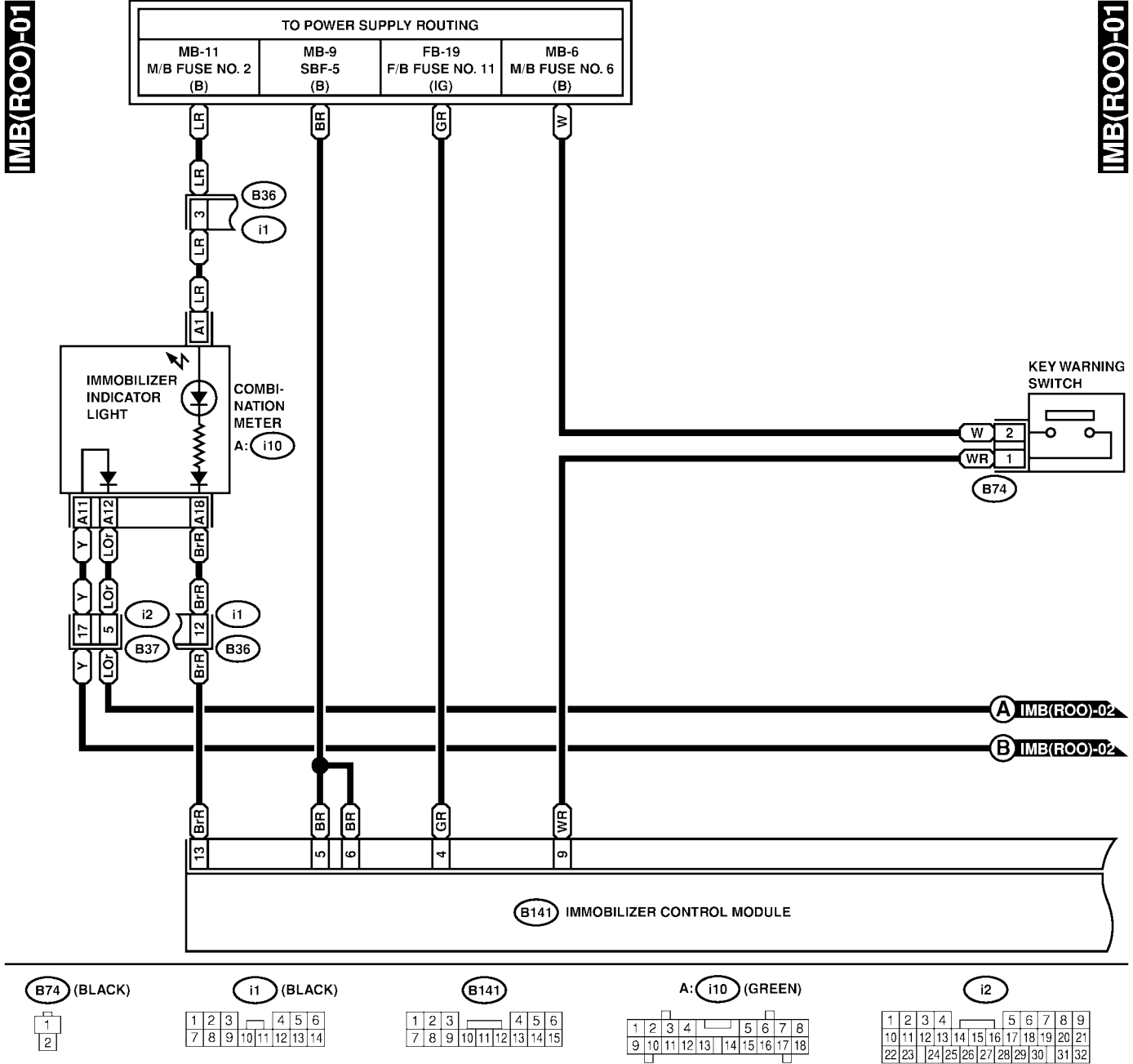

# IMMOBILIZER CONTROL MODULE I/O SIGNAL

Immobilizer (Diagnostics)

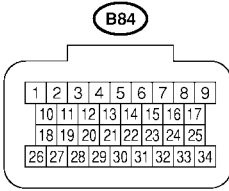
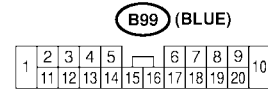
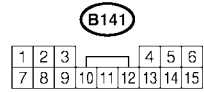
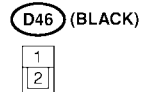
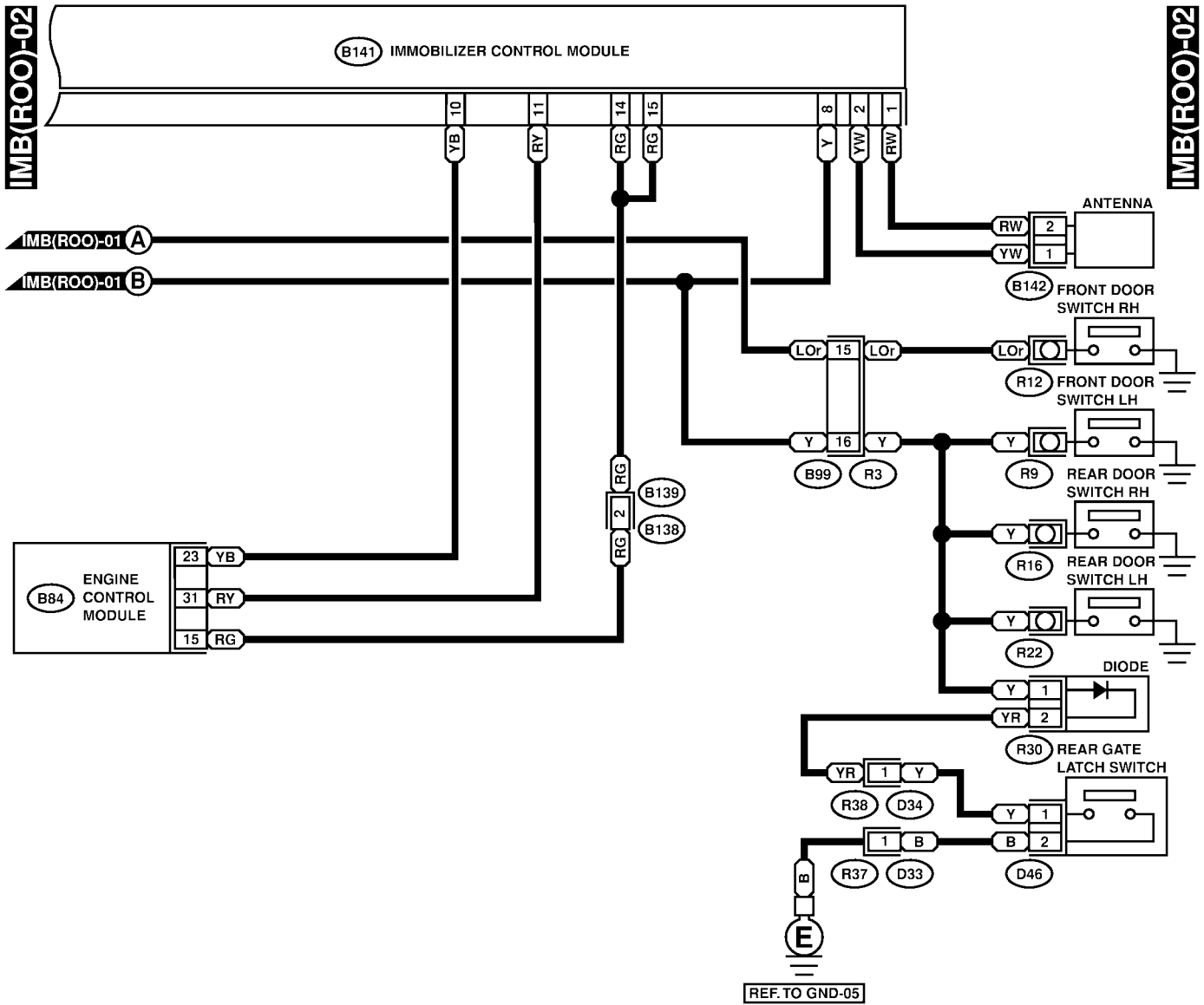

# SUBARU SELECT MONITOR

Immobilizer (Diagnostics)

## 5. Subaru Select Monitor S009503

### A: OPERATION S009503A16

#### 1. HOW TO USE SUBARU SELECT MONITOR S009503A1605

1) Prepare Subaru Select Monitor kit.

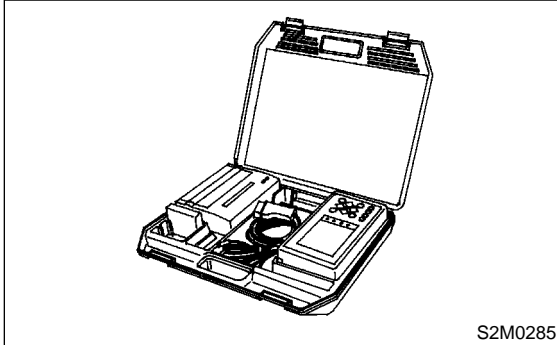

2) Connect diagnosis cable to Subaru Select Monitor.

3) Insert cartridge into Subaru Select Monitor.  
<Ref. to IM-4, SPECIAL TOOLS, PREPARATION TOOL, General Description.>

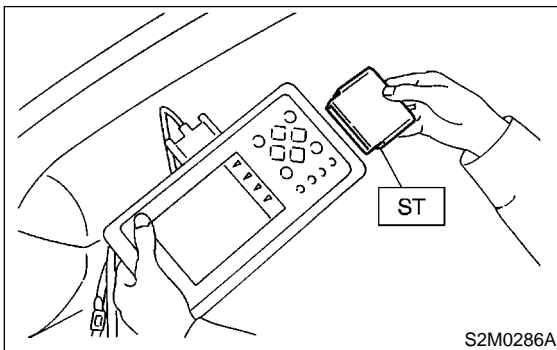

4) Connect Subaru Select Monitor to data link connector.

(1) Data link connector located in the lower portion of the instrument panel (on the driver's side).

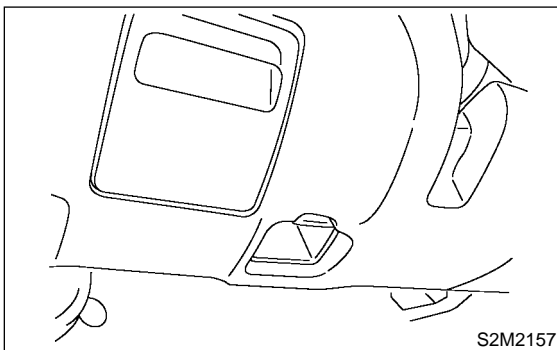

(2) Connect diagnosis cable to data link connector.

#### CAUTION:

Do not connect scan tools except for Subaru Select Monitor.

5) Turn ignition switch to ON (engine OFF) and Subaru Select Monitor switch to ON.

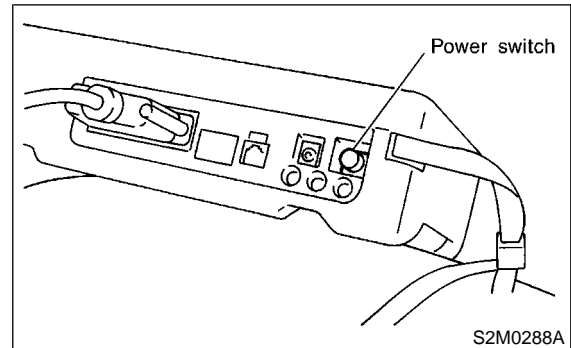

6) Using Subaru Select Monitor, call up diagnostic trouble code(s) and various data, then record them.

#### 2. READ DIAGNOSTIC TROUBLE CODE (DTC) FOR ENGINE. S009503A1606

Refer to Read Diagnostic Trouble Code for information about how to indicate DTC. <Ref. to IM-16, Read Diagnostic Trouble Code.>

#### 3. INTERFACE CHECK S009503A1604

##### NOTE:

Communication line between ECM and IMM ECM can be checked in «System Operation Check Mode». This is referred to as "interface check".

- 1) Connect select monitor.
- 2) Set the «System Operation Check Mode» menu display screen then select «Immobilizer System».
- 3) Screen indicates as shown.

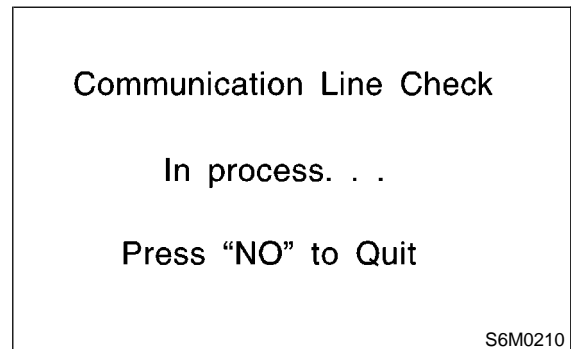

- 4) Start interface check.
- 5) Does "Communication Line not Shorted" appear on screen?  
If "YES". Go to step 6).  
If "NO". Go to step 7).

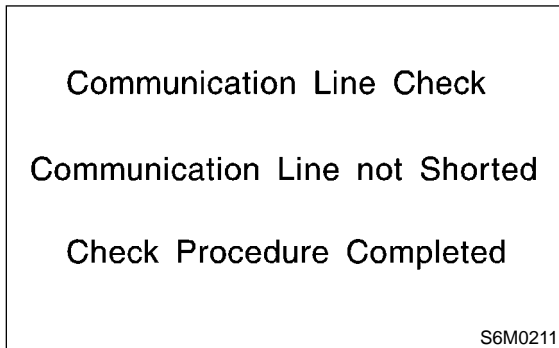

- 6) After diagnostic results, it is determined that short circuit is not a diagnostic item. This completes interface check.
- 7) If a problem is detected, repair. <Ref. to IM-27, DTC P1572 — IMM CIRCUIT FAILURE (EXCEPT ANTENNA CIRCUIT) —, Diagnostics Chart with Trouble Code.>



# READ DIAGNOSTIC TROUBLE CODE

Immobilizer (Diagnostics)

## 6. Read Diagnostic Trouble Code S009508

### A: OPERATION S009508A16

#### 1. WITH SUBARU SELECT MONITOR S009508A1601

- 1) On the «Main Menu» display screen, select the {Each System Check} and press the [YES] key.
- 2) On the «System Selection Menu» display screen, select the {Engine Control System} and press the [YES] key.
- 3) Press the [YES] key after displayed the information of engine type.
- 4) On the «Engine Diagnosis» display screen, select the {Diagnostic Code(s) Display} and press the [YES] key.
- 5) On the «Diagnostic Code(s) Display» display screen, select the {Current Diagnostic Code(s)} or {History Diagnostic Code(s)} and press the [YES] key.

#### NOTE:

- For detailed operation procedure, refer to the SUBARU SELECT MONITOR OPERATION MANUAL.
- For detailed concerning diagnostic trouble codes, refer to the List of Diagnostic Trouble Code (DTC). <Ref. to IM-25, LIST, List of Diagnostic Trouble Code.>

#### 2. WITHOUT SUBARU SELECT MONITOR S009508A1602

No.	Step	Check	Yes	No
1	<b>CHECK STATUS OF CHECK ENGINE MALFUNCTION INDICATOR LAMP (MIL).</b> 1) Turn ignition switch to OFF. 2) Connect read memory connector. <Ref. to EN(SOHCw/oOBD)-10, LOCATION, Electrical Components Location.> 3) Turn ignition switch to ON.	Does the MIL come on?	Go to step 2.	Check the following and repair if necessary. NOTE: ● Open or short circuit in engine control module power supply or ground line ● Open or short circuit in CHECK ENGINE malfunction indicator lamp
2	<b>CHECK DIAGNOSTIC TROUBLE CODE (DTC).</b>	Does the MIL indicate diagnostic trouble code (DTC)?	Record diagnostic trouble code (DTC). Then turn ignition switch to OFF, disconnect read memory connector.	Complete read diagnostic trouble code. Turn ignition switch to OFF and disconnect read memory connector.

# READ DIAGNOSTIC TROUBLE CODE

Immobilizer (Diagnostics)

The CHECK ENGINE malfunction indicator lamp (MIL) flashes the code corresponding to the faulty parts. The long segment (1.3 seconds ON) indicates a "ten", and the short segment (0.2 seconds ON) signifies "one". And middle segment (0.5 seconds ON) means OK code.

**NOTE:**

- For detailed concerning diagnostic trouble codes, refer to the List of Diagnostic Trouble Code (DTC).  
<Ref. to IM-25, LIST, List of Diagnostic Trouble Code.>

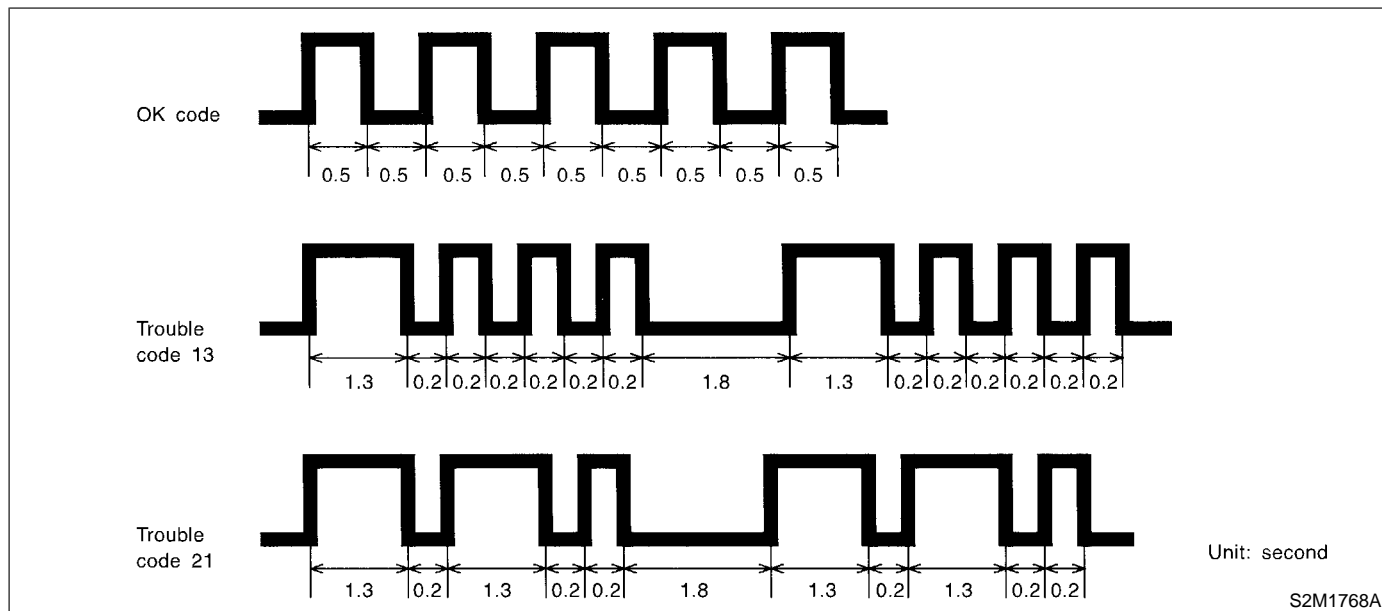

# CLEAR MEMORY MODE

Immobilizer (Diagnostics)

## 7. Clear Memory Mode S009513

### A: OPERATION S009513A16

#### 1. WITH SUBARU SELECT MONITOR

S009513A1601

- 1) On the «Main Menu» display screen, select the {2. Each System Check} and press the [YES] key.
- 2) On the «System Selection Menu» display screen, select the {Engine Control System} and press the [YES] key.
- 3) Press the [YES] key after displayed the information of engine type.
- 4) On the «Engine Diagnosis» display screen, select the {Clear Memory} and press the [YES] key.

#### 2. WITHOUT SUBARU SELECT MONITOR S009513A1602

- 5) When the 'Done' and 'Turn Ignition Switch OFF' are shown on the display screen, turn the Subaru Select Monitor and ignition switch to OFF.

#### NOTE:

- After the memory has been cleared, the ISC must be initialized. To do this, turn the ignition switch to the ON position. Wait 3 seconds before starting the engine.
- For detailed operation procedure, refer to the SUBARU SELECT MONITOR OPERATION MANUAL.

No.	Step	Check	Yes	No
1	<b>CHECK STATUS OF CHECK ENGINE MALFUNCTION INDICATOR LAMP (MIL).</b> 1) Turn ignition switch to OFF. 2) Set shift lever to neutral position (MT vehicles), or set selector lever to "P" position (AT vehicles). 3) Connect test mode connector and read memory connector. 4) Turn ignition switch to ON.	Does the MIL come on?	Go to step 2.	Check the following and repair if necessary. NOTE: ● Open or short circuit in engine control module power supply or ground line ● Open or short circuit in CHECK ENGINE malfunction indicator lamp
2	<b>CHECK DIAGNOSTIC TROUBLE CODE (DTC).</b> 1) Set selector lever "N" position, and then set selector lever to "P" position again (AT vehicles only). 2) Start the engine. 3) Drive vehicle at speed greater than 11 km/h (7 MPH) for at least one minute. 4) Warm-up engine above 2,000 rpm.	Does the MIL indicate diagnostic trouble code (DTC)? <Ref. to IM-25, LIST, List of Diagnostic Trouble Code.>	Record diagnostic trouble code. Repair the trouble cause.	Turn ignition switch to OFF, Disconnect read memory connector and test mode connector. Complete clear memory mode.

## 8. Diagnostics Chart for Immobilizer Indicator Light

S009641

### A: INSPECTION

S009641A10

#### 1. CHECK IMMOBILIZER INDICATOR CIRCUIT

S009641A1001

WIRING DIAGRAM (WITH OBD MODEL):

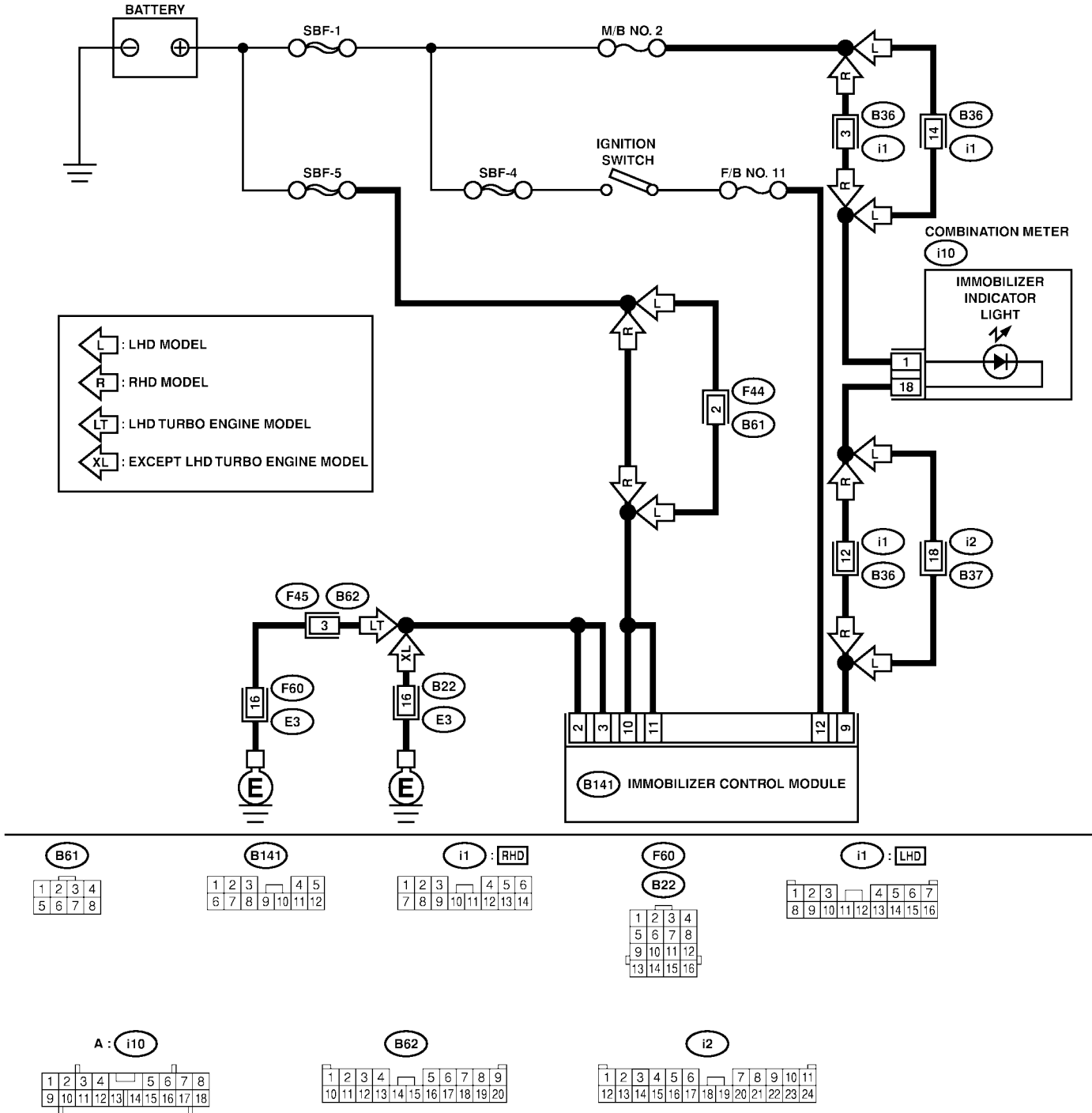

# DIAGNOSTICS CHART FOR IMMOBILIZER INDICATOR LIGHT

Immobilizer (Diagnostics)

## WIRING DIAGRAM (WITHOUT OBD MODEL):

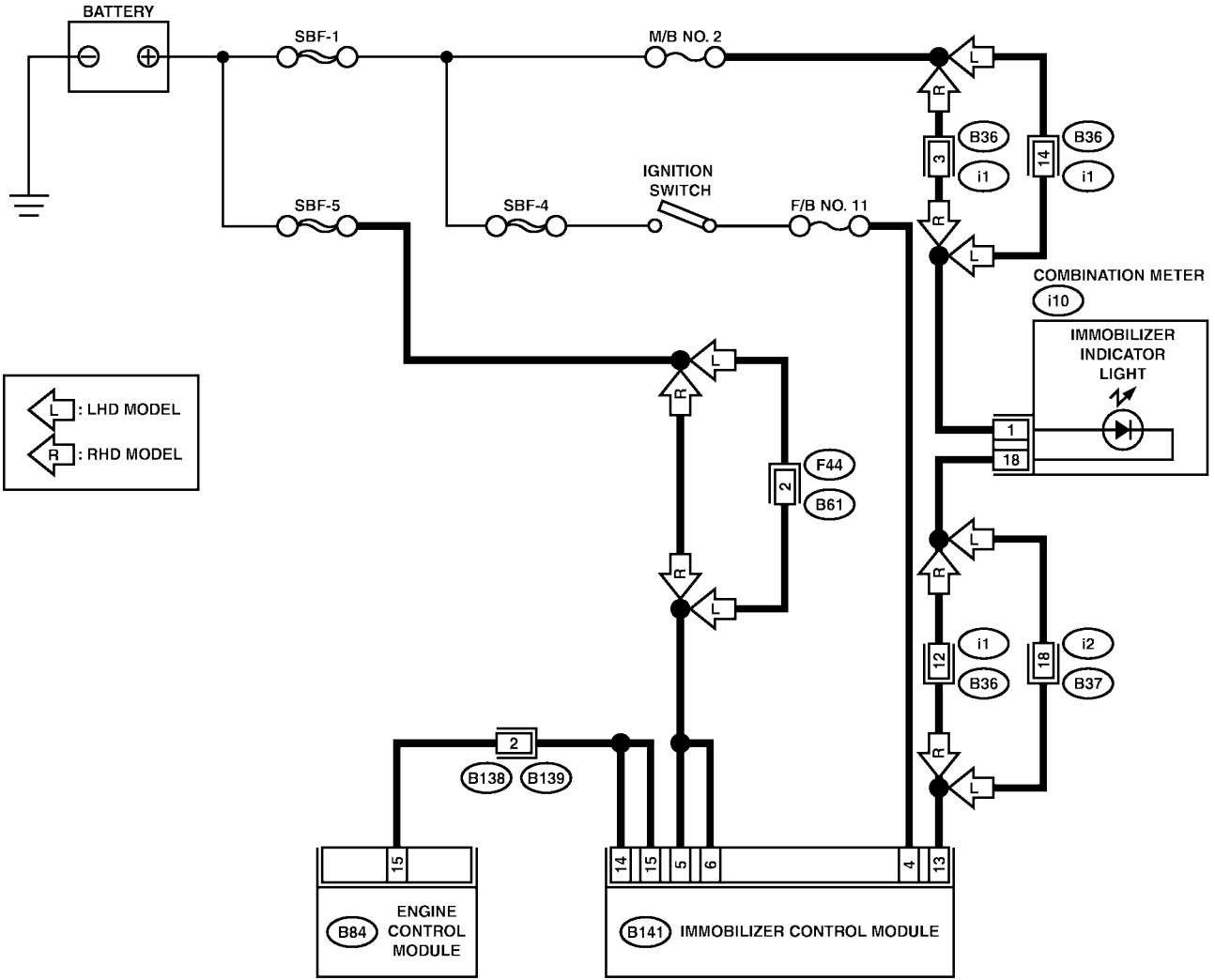

← L : LHD MODEL  
 ← R : RHD MODEL

**B138**

1	2
---	---

**B61**

1	2	3	4
5	6	7	8

**i1 : RHD**

1	2	3	4	5	6		
7	8	9	10	11	12	13	14

**B141**

1	2	3	4	5	6			
7	8	9	10	11	12	13	14	15

**i1 : LHD**

1	2	3	4	5	6	7		
8	9	10	11	12	13	14	15	16

**A : i10**

1	2	3	4	5	6	7	8		
9	10	11	12	13	14	15	16	17	18

**i2**

1	2	3	4	5	6	7	8	9	10	11		
12	13	14	15	16	17	18	19	20	21	22	23	24

**B84**

1	2	3	4	5	6	7	8	9
10	11	12	13	14	15	16	17	
18	19	20	21	22	23	24	25	
26	27	28	29	30	31	32	33	34

S6M0514

# DIAGNOSTICS CHART FOR IMMOBILIZER INDICATOR LIGHT

Immobilizer (Diagnostics)

No.	Step	Check	Yes	No
1	<p><b>CHECK IMMOBILIZER INDICATOR LIGHT COMES ON.</b>                      1) Turn ignition switch OFF.                      2) Disconnect harness connector from IMM ECM.                      3) Connect a resistor (750 Ω) between IMM ECM harness connector terminal No. 9 and chassis ground.</p>	Does indicator light comes on?	Go to step 2.	Go to step 5.
2	<p><b>CHECK IMM ECM GROUND CIRCUIT.</b>                      Measure resistance between IMM ECM harness connector terminal and chassis ground.  <b>Connector &amp; terminal</b>  <b>With OBD:</b>                      (B141) No. 2, No. 3 (+) — Chassis ground (-):  <b>Without OBD:</b>                      (B141) No. 14, No. 15 (+) — Chassis ground (-):</p>	Is the resistance less than 10 Ω?	Go to step 3.	Repair open circuit of IMM ECM ground circuit.
3	<p><b>CHECK IMM ECM IGNITION CIRCUIT.</b>                      1) Turn ignition switch ON. (Engine OFF.)                      2) Measure voltage between IMM ECM harness connector terminal and chassis ground.  <b>Connector &amp; terminal</b>  <b>With OBD:</b>                      (B141) No. 12 (+) — Chassis ground (-):  <b>Without OBD:</b>                      (B141) No. 4 (+) — Chassis ground (-):</p>	Is the voltage more than 10 V?	Go to step 4..	Check harness for open or short between IMM ECM and ignition switch.
4	<p><b>CHECK IMM ECM POWER SUPPLY CIRCUIT.</b>                      1) Turn ignition switch OFF.                      2) Measure voltage between IMM ECM harness connector terminal and chassis ground.  <b>Connector &amp; terminal</b>  <b>With OBD:</b>                      (B141) No. 10, No. 11 (+) — Chassis ground (-):  <b>Without OBD:</b>                      (B141) No. 5, No. 6 (+) — Chassis ground (-):</p>	Is the voltage more than 10 V?	Replace IMM ECM <Ref. to SL-42, Immobilizer Control Module.> and then replace all ignition keys (including the transponder). Then perform teaching operation. Refer to teaching operation manual (Pub. No. S0820GZ).	Check harness for open or short between IMM ECM and fuse.
5	<p><b>CHECK COMBINATION METER CIRCUIT.</b>                      1) Remove combination meter. &lt;Ref. to IDI-15, Combination Meter Assembly.&gt;                      2) Measure voltage between combination meter harness connector terminal and chassis ground.  <b>Connector &amp; terminal</b>                      (i10) No. 1 (+) — Chassis ground (-):</p>	Is the voltage more than 10 V?	Go to step 6.	Check harness for open or short between combination meter and fuse.
6	<p><b>CHECK COMBINATION METER CIRCUIT.</b>                      Measure resistance between IMM ECM harness connector terminal and combination meter harness connector terminal.  <b>Connector &amp; terminal</b>  <b>With OBD:</b>                      (B141) No. 9 — (i10) No. 18:  <b>Without OBD:</b>                      (B141) No. 13 (+) — (i10) No. 18:</p>	Is the resistance less than 10 Ω?	Faulty LED bulb. Replace combination meter printed circuit. <Ref. to IDI-15, DISASSEMBLY, Combination Meter Assembly.>	Repair harness or connector.

# DIAGNOSTICS CHART FOR IMMOBILIZER INDICATOR LIGHT

Immobilizer (Diagnostics)

## 2. CHECK KEY SWITCH CIRCUIT S009641A1002

### WIRING DIAGRAM (WITH OBD MODEL):

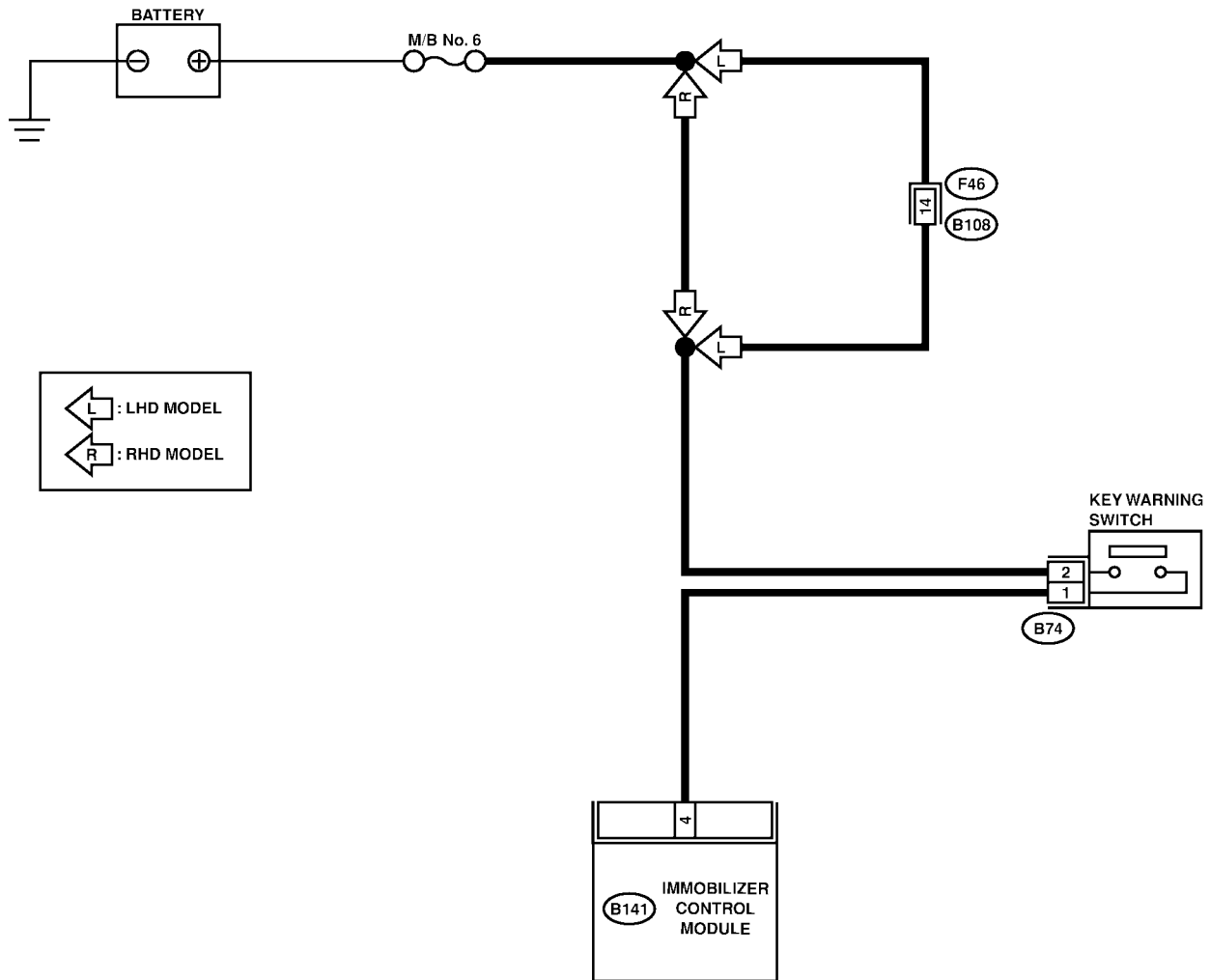

← L : LHD MODEL  
 ← R : RHD MODEL

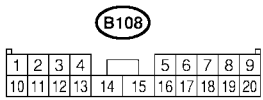
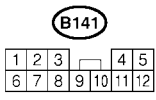
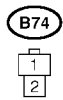

S6M0515

# DIAGNOSTICS CHART FOR IMMOBILIZER INDICATOR LIGHT

Immobilizer (Diagnostics)

## WIRING DIAGRAM (WITHOUT OBD MODEL):

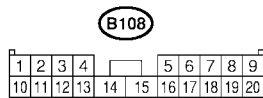
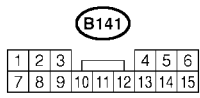
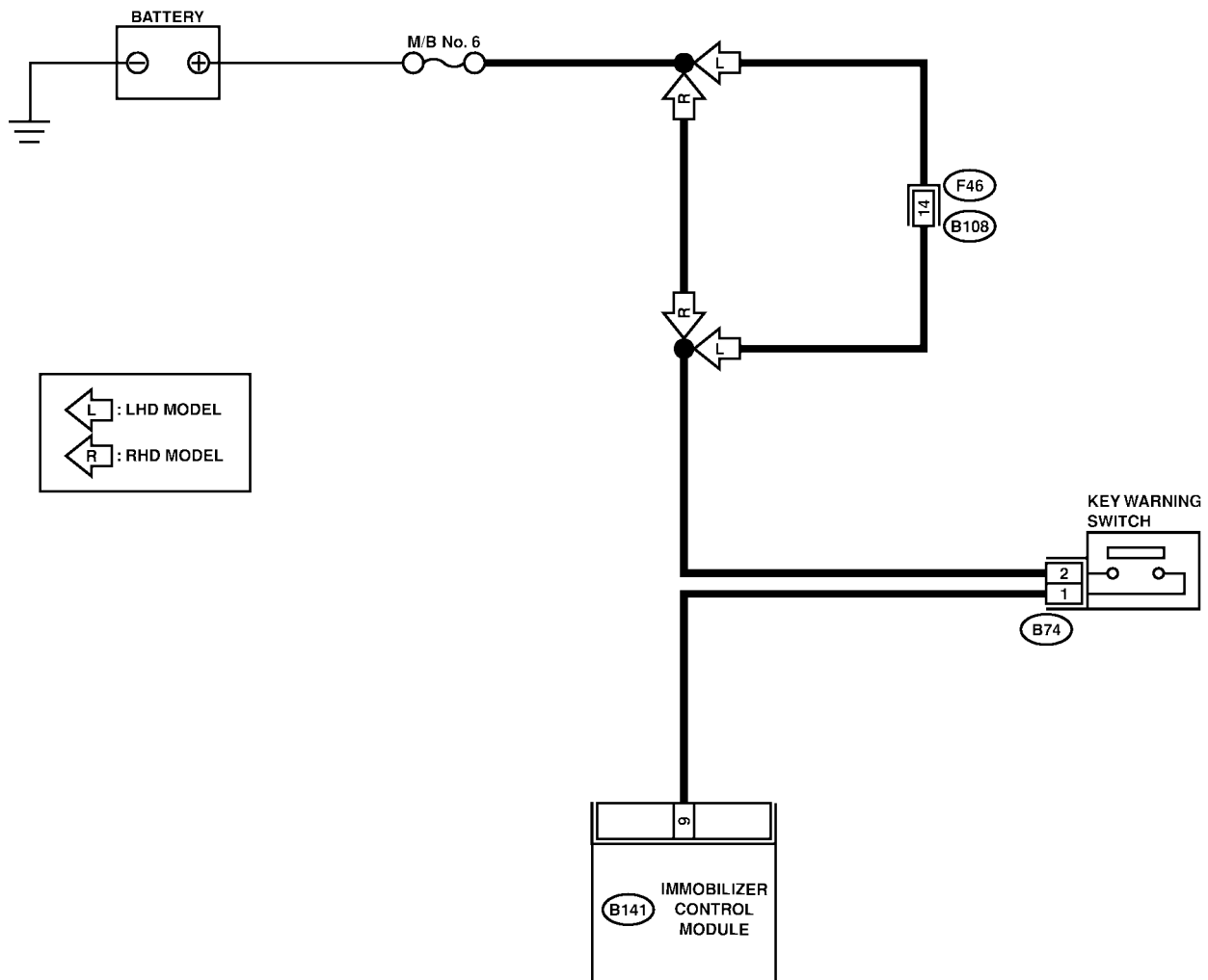

S6M0516



# DIAGNOSTICS CHART FOR IMMOBILIZER INDICATOR LIGHT

Immobilizer (Diagnostics)

No.	Step	Check	Yes	No
1	<p><b>CHECK POWER SUPPLY CIRCUIT.</b></p> <p>1) Disconnect harness connector from key warning switch.</p> <p>2) Turn ignition switch ACC or LOCK position (The key inserted).</p> <p>3) Measure voltage between key warning switch harness connector terminal and chassis ground.</p> <p><b>Connector &amp; terminal</b> <b>(B74) No. 2 (+) — Chassis ground (-):</b></p>	Is the voltage more than 10 V?	Go to step 2.	Check harness for open or short between key warning switch and fuse.
2	<p><b>CHECK KEY SWITCH.</b></p> <p>1) Insert the ignition key to the ignition switch. (OFF or ACC position)</p> <p>2) Check continuity between key warning switch connector terminals.</p> <p><b>Connector &amp; terminal</b> <b>No. 1 — No. 2:</b></p>	Dose continuity exist?	Go to step 3.	Replace key warning switch.
3	<p><b>CHECK KEY SWITCH.</b></p> <p>1) Remove the ignition key from the ignition switch.</p> <p>2) Check continuity between key warning switch connector terminals.</p> <p><b>Connector &amp; terminal</b> <b>No. 1 — No. 2:</b></p>	Does continuity exist?	Replace key warning switch.	Go to step 4.
4	<p><b>CHECK HARNESS BETWEEN KEY SWITCH AND IMM ECM.</b></p> <p>1) Disconnect harness connector from key warning switch.</p> <p>2) Disconnect harness connector from IMM ECM.</p> <p>3) Measure resistance between key warning switch harness connector terminal and IMM ECM harness connector terminal.</p> <p><b>Connector &amp; terminal</b> <b>With OBD:</b> <b>(B74) No. 1 — (B141) No. 4:</b> <b>Without OBD:</b> <b>(B74) No. 1 — (B141) No. 9:</b></p>	Is the resistance less than 10 Ω?	Replace IMM ECM <Ref. to SL-42, Immobilizer Control Module.> and then replace all ignition keys (including the transponder). Then perform teaching operation. Refer to teaching operation manual (Pub. No. S0820GZ).	Repair harness between key warning switch and IMM ECM.

**9. List of Diagnostic Trouble Code** S009511

**A: LIST** S009511A12

DTC		Item	Contents of diagnosis	Index No.
Without OBD	With OBD			
53	P1571	Reference Code Incompatibility	Reference code incompatibility between IMM ECM and ECM	<Ref. to IM-26, DTC P1571 — REFERENCE CODE INCOMPATIBILITY —, Diagnostics Chart with Trouble Code.>
	P1572	IMM Circuit Failure (Except Antenna Circuit)	Communication failure between IMM ECM and ECM	<Ref. to IM-27, DTC P1572 — IMM CIRCUIT FAILURE (EXCEPT ANTENNA CIRCUIT) —, Diagnostics Chart with Trouble Code.>
	P1574	Key Communication Failure	Failure of IMM ECM to verify key (transponder) ID code	<Ref. to IM-33, DTC P1574 — KEY COMMUNICATION FAILURE —, Diagnostics Chart with Trouble Code.>
	P0153	Use of Unregistered Key	Incorrect immobilizer key (Use of unregistered key in IMM ECM)	<Ref. to IM-34, DTC P0153 — INNCORRECT IMMOBILIZER KEY (USE OF UNREGISTERED KEY) —, Diagnostics Chart with Trouble Code.>
	P1576	EGI Control Module EEPROM	ECM malfunctioning	<Ref. to IM-34, DTC P1576 — EGI CONTROL MODULE EEPROM —, Diagnostics Chart with Trouble Code.>
	P1577	IMM Control Module EEPROM	IMM ECM malfunctioning	<Ref. to IM-34, DTC P1577 — IMM CONTROL MODULE EEPROM —, Diagnostics Chart with Trouble Code.>
	P1570	ANTENNA	Faulty antenna	<Ref. to IM-35, DTC P1570 — ANTENNA —, Diagnostics Chart with Trouble Code.>

**NOTE:**

- When reading diagnostic trouble code except with SUBARU SELECT MONITOR, the item cannot be specified. Therefore diagnose for all items.
- When a diagnostic trouble code except for the above immobilizer trouble code has been output, carry out diagnosis for the engine trouble code. <Ref. to EN(SOHC)-80, List of Diagnostic Trouble Code (DTC).> or <Ref. to EN(SOHCw/oOBD)-65, List of Diagnostic Trouble Code (DTC).> or <Ref. to EN(DOHC TURBO)-82, List of Diagnostic Trouble Code (DTC).>

# DIAGNOSTICS CHART WITH TROUBLE CODE

Immobilizer (Diagnostics)

## 10. Diagnostics Chart with Trouble Code S009620

### A: DTC P1571 — REFERENCE CODE INCOMPATIBILITY — S009620H45

#### DIAGNOSIS:

- Reference code incompatibility between IMM ECM and ECM

No.	Step	Check	Yes	No
1	<b>PERFORM TEACHING OPERATION ON IGNITION KEY.</b> Perform teaching operation on all keys of the vehicle. Refer to teaching operation manual.	Is teaching operation for all keys completed?	END	Replace ECM. <Ref. to FU(SOHC)-49, Engine Control Module.>, <Ref. to FU(SOHCw/oOBD)-38, Engine Control Module.>, or <Ref. to FU(DOHC TURBO)-47, Engine Control Module.>, IMM ECM <Ref. to SL-42, Immobilizer Control Module.> and then replace all ignition keys (including the transponder). Then perform teaching operation. Refer to teaching operation manual (Pub. No. S0820GZ).

# DIAGNOSTICS CHART WITH TROUBLE CODE

Immobilizer (Diagnostics)

## B: DTC P1572 — IMM CIRCUIT FAILURE (EXCEPT ANTENNA CIRCUIT) —

S009620H46

### DIAGNOSIS:

- Communication failure between IMM ECM and ECM

### WIRING DIAGRAM (WITH OBD MODEL):

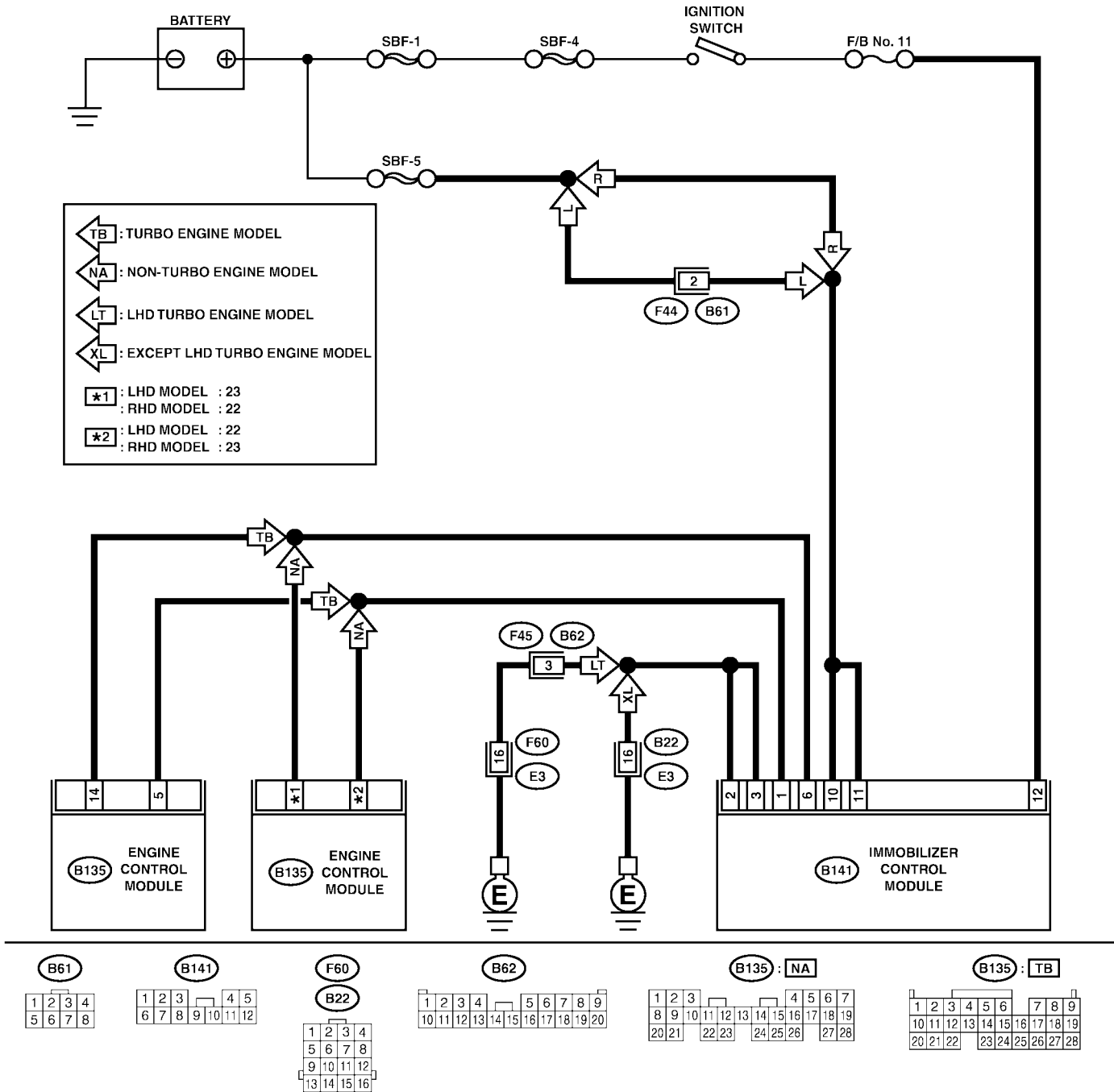

S6M0517

# DIAGNOSTICS CHART WITH TROUBLE CODE

Immobilizer (Diagnostics)

## WIRING DIAGRAM (WITHOUT OBD MODEL):

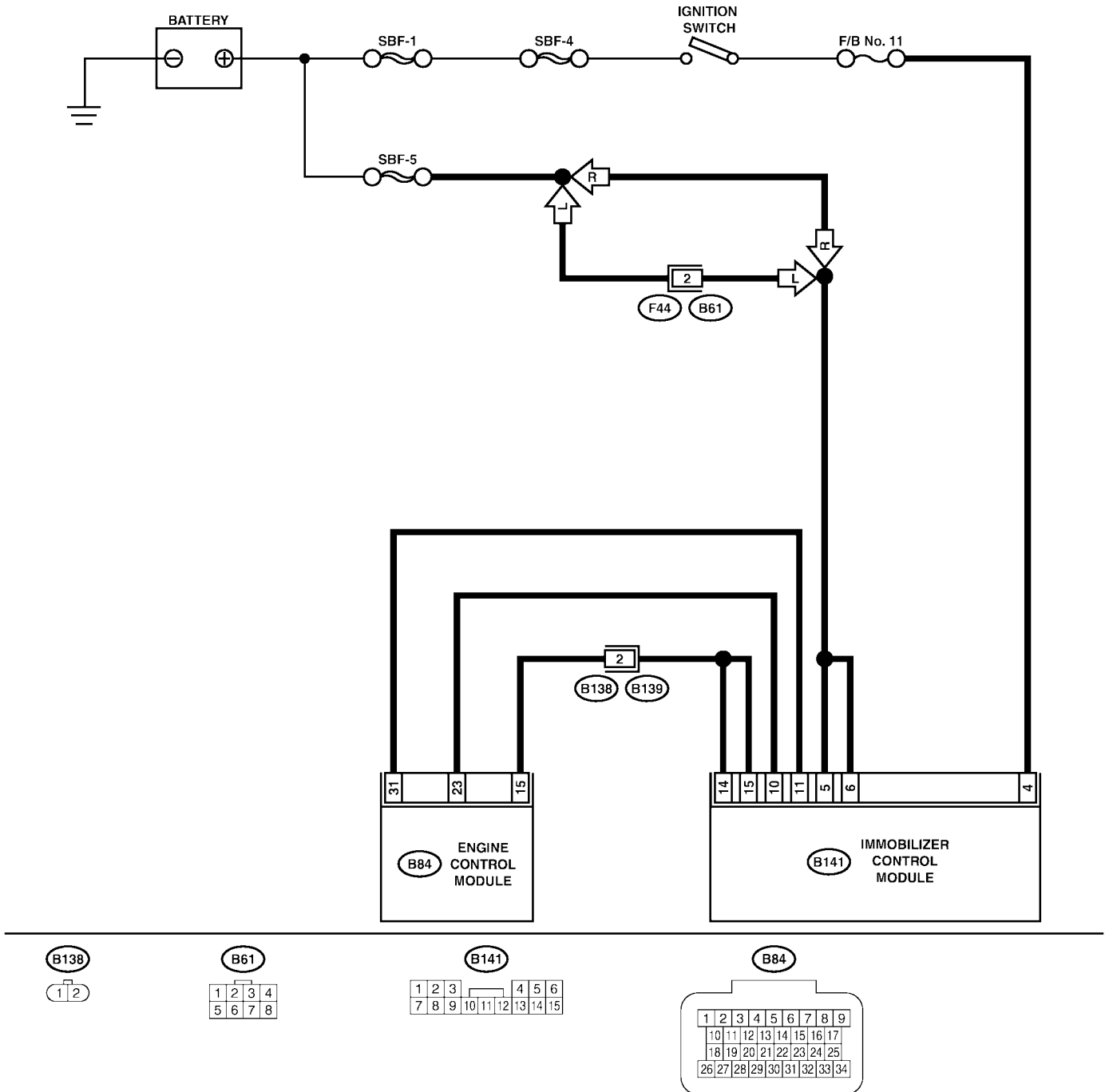

S6M0518

# DIAGNOSTICS CHART WITH TROUBLE CODE

Immobilizer (Diagnostics)

No.	Step	Check	Yes	No
1	<p><b>CHECK POWER SUPPLY CIRCUIT OF IMM ECM.</b></p> <p>1) Turn ignition switch OFF. 2) Disconnect harness connector from IMM ECM. 3) Measure voltage between IMM ECM harness connector terminal and chassis ground.</p> <p><b>Connector &amp; terminal</b> <b>With OBD:</b> <b>(B141) No. 10, No. 11 (+) — Chassis ground (-):</b> <b>Without OBD:</b> <b>(B141) No. 5, No. 6 (+) — Chassis ground (-):</b></p>	Is the voltage more than 10 V?	Go to step 2.	Check harness for open or short between IMM ECM and fuse.
2	<p><b>CHECK POWER SUPPLY CIRCUIT OF IMM ECM.</b></p> <p>1) Turn ignition switch ON. (Engine OFF.) 2) Measure voltage between IMM ECM harness connector terminal and chassis ground.</p> <p><b>Connector &amp; terminal</b> <b>With OBD:</b> <b>(B141) No. 12 (+) — Chassis ground (-):</b> <b>Without OBD:</b> <b>(B141) No. 4 (+) — Chassis ground (-):</b></p>	Is the voltage more than 10 V?	Go to step 3.	Check harness for open or short between IMM ECM and ignition switch.
3	<p><b>CHECK GROUND CIRCUIT OF IMM ECM.</b></p> <p>1) Turn ignition switch OFF. 2) Measure resistance between IMM ECM harness connector terminal and chassis ground.</p> <p><b>Connector &amp; terminal</b> <b>With OBD:</b> <b>(B141) No. 2, No. 3 (+) — Chassis ground (-):</b> <b>Without OBD:</b> <b>(B141) No. 14, No. 15 (+) — Chassis ground (-):</b></p>	Is the resistance less than 10 Ω?	Go to step 4.	Repair open circuit of IMM ECM ground circuit.
4	<p><b>CHECK HARNESS BETWEEN IMM ECM AND ECM.</b></p> <p>1) Disconnect harness connector from ECM and IMM ECM. 2) Measure resistance between IMM ECM harness connector terminal and ECM harness connector terminal.</p> <p><b>Connector &amp; terminal</b> <b>With OBD (turbo):</b> <b>(B141) No. 1 — (B135) No. 5:</b> <b>With OBD (LHD non-turbo):</b> <b>(B141) No. 1 — (B135) No. 22:</b> <b>With OBD (RHD non-turbo):</b> <b>(B141) No. 1 — (B135) No. 23:</b> <b>Without OBD:</b> <b>(B141) No. 10 — (B84) No. 23:</b></p>	Is the resistance less than 10 Ω?	Go to step 5.	Repair open circuit of harness between IMM ECM and ECM.

# DIAGNOSTICS CHART WITH TROUBLE CODE

Immobilizer (Diagnostics)

No.	Step	Check	Yes	No
5	<p><b>CHECK HARNESS BETWEEN IMM ECM AND ECM.</b> Measure resistance between IMM ECM harness connector terminal and ECM harness connector terminal.</p> <p><b>Connector &amp; terminal</b> <b>With OBD (turbo):</b> (B141) No. 6 (+) — (B135) No. 14 (-): <b>With OBD (LHD non-turbo):</b> (B141) No. 6 (+) — (B135) No. 23 (-): <b>With OBD (RHD non-turbo):</b> (B141) No. 6 — (B135) No. 22: <b>Without OBD:</b> (B141) No. 11 — (B84) No. 31:</p>	Is the resistance less than 10 Ω?	Go to step 6.	Repair open circuit of harness between IMM ECM and ECM.
6	<p><b>CHECK HARNESS OF COMMUNICATION LINE.</b> 1) Turn ignition switch ON. (Engine OFF.) 2) Measure voltage between IMM ECM harness connector terminal and chassis ground.</p> <p><b>Connector &amp; terminal</b> <b>With OBD:</b> (B141) No. 1, No. 6 (+) — Chassis ground (-): <b>Without OBD:</b> (B141) No. 10, No. 11 (+) — Chassis ground (-):</p>	Is the voltage 0 V?	Go to step 7.	Repair harness between IMM ECM and ECM, because there is short circuit in battery voltage line or ignition switch "ON" line.
7	<p><b>CHECK HARNESS OF COMMUNICATION LINE.</b> Measure voltage between ECM harness connector terminal and engine ground.</p> <p><b>Connector &amp; terminal</b> <b>With OBD (turbo):</b> (B135) No. 5, No. 14 (+) — Chassis ground (-): <b>With OBD (non-turbo):</b> (B135) No. 22, No. 23 (+) — Chassis ground (-): <b>Without OBD:</b> (B84) No. 23, No. 31 (+) — Chassis ground (-):</p>	Is the voltage 0 V?	Go to step 8.	Repair harness between IMM ECM and ECM, because there is short circuit in battery voltage line or ignition switch "ON" line.
8	<p><b>CHECK ECM BY INTERFACE CHECK.</b> 1) Connect harness connector to ECM. 2) Disconnect harness connector from IMM ECM. 3) Perform interface check. &lt;Ref. to IM-14, INTERFACE CHECK, OPERATION, Subaru Select Monitor.&gt;</p>	Does "Commun. Line Shorted to Ground" appear on screen?	Replace ECM. <Ref. to FU(SOHC)-49, Engine Control Module.>, <Ref. to FU(SOHCw/oOBD)-38, Engine Control Module.>, or <Ref. to FU(DOHC TURBO)-47, Engine Control Module.> Then perform teaching operation. Refer to teaching operation manual (Pub. No. S0820GZ).	Go to step 9.

# DIAGNOSTICS CHART WITH TROUBLE CODE

Immobilizer (Diagnostics)

No.	Step	Check	Yes	No
9	<b>CHECK ECM BY INTERFACE CHECK.</b> Perform interface check.	Does "Commun. Line Shorted to Battery" appear on screen?	Replace ECM. <Ref. to FU(SOHC)-49, Engine Control Module.>, <Ref. to FU(SOHCw/oOBD)-38, Engine Control Module.> or <Ref. to FU(DOHC TURBO)-47, Engine Control Module.> Then perform teaching operation. Refer to teaching operation manual (Pub. No. S0820GZ).	Go to step 10.
10	<b>CHECK ECM BY INTERFACE CHECK.</b> Perform interface check.	Does "Communication Line not Shorted" appear on screen?	Replace IMM ECM <Ref. to SL-42, Immobilizer Control Module.> and then replace all ignition keys (including the transponder). Then perform teaching operation. Refer to teaching operation manual (Pub. No. S0820GZ).	When " <b>Check (Time Out)</b> " appears on screen, perform interface check again.



# DIAGNOSTICS CHART WITH TROUBLE CODE

Immobilizer (Diagnostics)

---

**MEMO:**

# DIAGNOSTICS CHART WITH TROUBLE CODE

Immobilizer (Diagnostics)

## C: DTC P1574 — KEY COMMUNICATION FAILURE — S009620H47

### DIAGNOSIS:

- Failure of IMM ECM to verify key (transponder) ID code

No.	Step	Check	Yes	No
1	<p><b>CHECK IMM ECM FUNCTION.</b>                      Insert the key to ignition switch (LOCK position), measure changes in voltage between Antenna connector.  <b>Connector &amp; terminal</b>  <b>(B142) No. 1 — No. 2:</b></p>	Is the voltage -30 to 30 V? (Approximately 0.1 second after inserting the key.) Is the voltage 0 V? (Approximately 1 second after inserting the key.)	Go to step 2.	Replace IMM ECM <Ref. to SL-42, Immobilizer Control Module.> and then replace all ignition keys (including the transponder). Then perform teaching operation. Refer to teaching operation manual (Pub. No. S0820GZ).
2	<p><b>CHECK IGNITION KEY (TRANSPONDER).</b>                      1) Remove the key from ignition switch.                      2) Start engine using other keys that have undergone the teaching operation, furnished with vehicle.</p>	Does engine start?	Replace ignition key (including the transponder). Then perform teaching operation. Refer to teaching operation manual (Pub. No. S0820GZ).	Replace IMM ECM <Ref. to SL-42, Immobilizer Control Module.> and then replace all ignition keys (including the transponder). Then perform teaching operation. Refer to teaching operation manual (Pub. No. S0820GZ).

## DIAGNOSTICS CHART WITH TROUBLE CODE

Immobilizer (Diagnostics)

### D: DTC P0153 — INCORRECT IMMOBILIZER KEY (USE OF UNREGISTERED KEY) — S009620H48

**DIAGNOSIS:**

- Use of unregistered key in IMM ECM

No.	Step	Check	Yes	No
1	<b>PERFORM TEACHING OPERATION ON IGNITION KEY.</b> Perform teaching operation on all keys of the vehicle. Refer to teaching operation manual (Pub. No. S0820GZ).	Is teaching operation for all keys completed?	END	Replace all ignition keys (including the transponder). Go to step 2.
2	<b>PERFORM TEACHING OPERATION ON IGNITION KEY.</b> Perform teaching operation on all keys with vehicle. Refer to teaching operation manual (Pub. No. S0820GZ).	Is teaching operation for all keys completed?	END	Replace IMM ECM <Ref. to SL-42, Immobilizer Control Module.> and then replace all ignition keys (including the transponder). Then perform teaching operation. Refer to teaching operation manual (Pub. No. S0820GZ).

### E: DTC P1576 — EGI CONTROL MODULE EEPROM — S009620H49

**DIAGNOSIS:**

- ECM malfunctioning

**1. REPLACE ECM.** S009620H4901

Replace ECM.

<Ref. to FU(SOCH)-49, Engine Control Module.>,

<Ref. to FU(SOHCw/oOBD)-38, Engine Control Module.> or <Ref. to FU(DOHC TURBO)-47, Engine Control Module.>

Then perform teaching operation. Refer to teaching operation manual (Pub. No. S0820GZ).

### F: DTC P1577 — IMM CONTROL MODULE EEPROM — S009620H50

**DIAGNOSIS:**

- IMM ECM malfunctioning

**1. REPLACE IMM ECM.** S009620H5001

Replace IMM ECM <Ref. to SL-42, Immobilizer Control Module.> and then replace all ignition keys (including the transponder). Then perform teaching operation. Refer to teaching operation manual (Pub. No. S0820GZ).

## G: DTC P1570 — ANTENNA — S009620H51

### DIAGNOSIS:

- Faulty antenna

### WIRING DIAGRAM (WITH OBD MODEL):

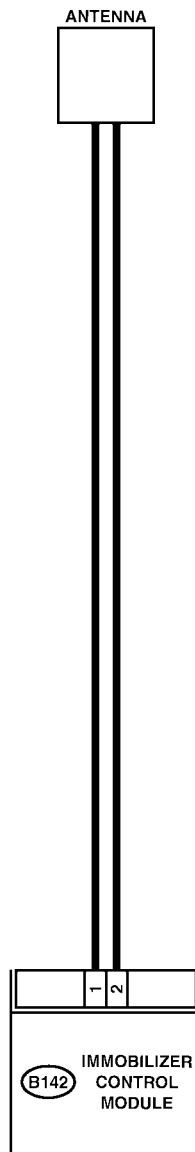

B142

1 2

# DIAGNOSTICS CHART WITH TROUBLE CODE

Immobilizer (Diagnostics)

## WIRING DIAGRAM (WITHOUT OBD MODEL):

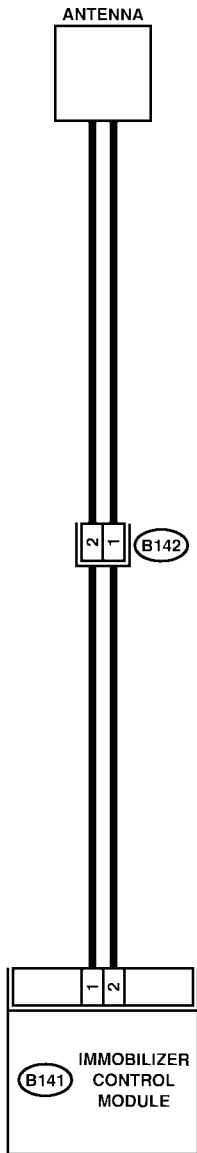

B142



B141

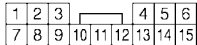

S6M0519

# DIAGNOSTICS CHART WITH TROUBLE CODE

Immobilizer (Diagnostics)

No.	Step	Check	Yes	No
1	<b>CHECK ENGINE TYPE.</b>	Is the vehicle with OBD?	Go to step 2.	Go to step 8.
2	<b>CHECK ANTENNA CIRCUIT.</b> 1) Turn ignition switch OFF. Disconnect harness antenna connector from IMM ECM. <Ref. to SL-43, Immobilizer Antenna.> 2) Measure resistance of antenna circuit. <b>Connector &amp; terminal</b> <b>(B142) No. 1 — No. 2:</b>	Is the resistance less than 10 Ω?	Go to step 3.	Replace antenna. <Ref. to SL-43, Immobilizer Antenna.>
3	<b>CHECK ANTENNA CIRCUIT.</b> Measure resistance between antenna harness connector and chassis ground. <b>Connector &amp; terminal</b> <b>(B142) No. 1 (+) — Chassis ground (-):</b>	Is the resistance less than 10 Ω?	Replace antenna. <Ref. to SL-43, Immobilizer Antenna.>	Go to step 4.
4	<b>CHECK ANTENNA CIRCUIT.</b> Measure resistance between antenna harness connector and chassis ground. <b>Connector &amp; terminal</b> <b>(B142) No. 2 (+) — Chassis ground (-):</b>	Is the resistance less than 10 Ω?	Replace antenna. <Ref. to SL-43, Immobilizer Antenna.>	Go to step 5.
5	<b>CHECK ANTENNA CIRCUIT.</b> 1) Turn ignition switch ON. (Engine OFF.) 2) Measure voltage between antenna harness connector and chassis ground. <b>Connector &amp; terminal</b> <b>(B142) No. 1 (+) — Chassis ground (-):</b>	Is the voltage 0 V?	Go to step 6.	Replace antenna. <Ref. to SL-43, Immobilizer Antenna.>
6	<b>CHECK ANTENNA CIRCUIT.</b> Measure voltage between antenna harness connector and chassis ground. <b>Connector &amp; terminal</b> <b>(B142) No. 2 (+) — Chassis ground (-):</b>	Is the voltage 0 V?	Go to step 7.	Replace antenna. <Ref. to SL-43, Immobilizer Antenna.>
7	<b>CHECK IMM ECM FUNCTION.</b> 1) Turn ignition switch OFF. 2) Connect antenna harness connector to IMM ECM. 3) Insert the key to ignition switch, measure changes in voltage between antenna harness connector. <b>Connector &amp; terminal</b> <b>(B142) No. 1 — No. 2:</b>	Is the voltage -30 to 30 V? (Approximately 0.1 second after inserting the key.) Is the voltage 0 V? (Approximately 1 second after inserting the key.)	Go to step 15.	Replace IMM ECM <Ref. to SL-42, Immobilizer Control Module.> and then replace all ignition keys (including the transponder). Then perform teaching operation. Refer to teaching operation manual (Pub. No. S0820GZ).
8	<b>CHECK ANTENNA CIRCUIT.</b> 1) Turn ignition switch OFF. 2) Disconnect harness antenna connector. <Ref. to SL-43, Immobilizer Antenna.> 3) Measure resistance of antenna circuit. <b>Connector &amp; terminal</b> <b>(B142) No. 1 — No. 2:</b>	Is the resistance less than 10 Ω?	Go to step 9.	Replace antenna. <Ref. to SL-43, Immobilizer Antenna.>

## DIAGNOSTICS CHART WITH TROUBLE CODE

Immobilizer (Diagnostics)

No.	Step	Check	Yes	No
9	<b>CHECK ANTENNA CIRCUIT.</b> 1) Disconnect IMM ECM harness connector. 2) Measure resistance between IMM ECM harness connector terminal and antenna harness connector terminal. <b>Connector &amp; terminal</b> (B141) No. 1 — (B142) No. 2: (B141) No. 2 — (B142) No. 1:	Is the resistance less than 10 Ω?	Go to step 10.	Repair harness between IMM ECM and antenna harness connector.
10	<b>CHECK ANTENNA CIRCUIT.</b> Measure resistance between IMM ECM harness connector and chassis ground. <b>Connector &amp; terminal</b> (B141) No. 1 (+) — Chassis ground (-):	Is the resistance less than 10 Ω?	Repair harness between IMM ECM and antenna harness connector.	Go to step 11.
11	<b>CHECK ANTENNA CIRCUIT.</b> Measure resistance between IMM ECM harness connector and chassis ground. <b>Connector &amp; terminal</b> (B141) No. 2 (+) — Chassis ground (-):	Is the resistance less than 10 Ω?	Repair harness between IMM ECM and antenna harness connector.	Go to step 12.
12	<b>CHECK ANTENNA CIRCUIT.</b> 1) Turn ignition switch ON. (Engine OFF.) 2) Measure voltage between IMM ECM harness connector and chassis ground. <b>Connector &amp; terminal</b> (B141) No. 1 (+) — Chassis ground (-):	Is the voltage 0 V?	Go to step 13.	Repair harness between IMM ECM and antenna harness connector.
13	<b>CHECK ANTENNA CIRCUIT.</b> Measure voltage between IMM ECM harness connector and chassis ground. <b>Connector &amp; terminal</b> (B141) No. 2 (+) — Chassis ground (-):	Is the voltage 0 V?	Go to step 14.	Repair harness between IMM ECM and antenna harness connector.
14	<b>CHECK IMM ECM FUNCTION.</b> 1) Turn ignition switch OFF. 2) Connect antenna harness connector and IMM ECM harness connector. 3) Insert the key to ignition switch, measure changes in voltage between IMM ECM harness connector. <b>Connector &amp; terminal</b> (B141) No. 1 — No. 2:	Is the voltage -30 to 30 V? (Approximately 0.1 second after inserting the key.) Is the voltage 0 V? (Approximately 1 second after inserting the key.)	Go to step 15.	Replace IMM ECM <Ref. to SL-42, Immobilizer Control Module.> and then replace all ignition keys (including the transponder). Then perform teaching operation. Refer to teaching operation manual (Pub. No. S0820GZ).
15	<b>CHECK IGNITION KEY (TRANSPONDER).</b> 1) Remove key from ignition switch. 2) Start engine using other keys that have undergone the teaching operation, furnished with vehicle.	Does engine start?	Replace ignition key (including the transponder). Then perform teaching operation. Refer to teaching operation manual (Pub. No. S0820GZ).	Replace IMM ECM <Ref. to SL-42, Immobilizer Control Module.> and then replace all ignition keys (including the transponder). Then perform teaching operation. Refer to teaching operation manual (Pub. No. S0820GZ).