

BODY SECTION

This service manual has been prepared to provide SUBARU service personnel with the necessary information and data for the correct maintenance and repair of SUBARU vehicles.

This manual includes the procedures for maintenance, disassembling, reassembling, inspection and adjustment of components and diagnostics for guidance of experienced mechanics.

Please peruse and utilize this manual fully to ensure complete repair work for satisfying our customers by keeping their vehicle in optimum condition. When replacement of parts during repair work is needed, be sure to use SUBARU genuine parts.

All information, illustration and specifications contained in this manual are based on the latest product information available at the time of publication approval.

FUJI HEAVY INDUSTRIES LTD.

**HVAC SYSTEM
(HEATER, VENTILATOR AND A/C) AC**

AIRBAG SYSTEM AB

SEAT BELT SYSTEM SB

LIGHTING SYSTEM LI

WIPER AND WASHER SYSTEMS WW

ENTERTAINMENT ET

COMMUNICATION SYSTEM COM

GLASS/WINDOWS/MIRRORS GW

BODY STRUCTURE BS

INSTRUMENTATION/DRIVER INFO IDI

SEATS SE

SECURITY AND LOCKS SL

**SUNROOF/T-TOP/CONVERTIBLE TOP
(SUNROOF) SR**

EXTERIOR/INTERIOR TRIM EI

EXTERIOR BODY PANELS EB

CRUISE CONTROL SYSTEM CC

BODY STRUCTURE

BS

	Page
1. General Description.....	2
2. Datum Points.....	3
3. Datum Dimensions.....	15



GENERAL DESCRIPTION

Body Structure

1. General Description S906001

A: PREPARATION TOOL S906001A17

TOOL NAME	REMARKS
Tram tracking gauge	Used for measuring dimension.
Tape measure	Used for measuring dimension

2. Datum Points S906540

A: LOCATION S906540A13

NOTE:

- Datum points are specified for body repair.
- Guide holes, locators, and indents are provided to facilitate panel replacement and to increase alignment accuracy.
- Both right and left reference points are symmetrical.

DATUM POINTS

Body Structure

1. ROOM SECTION S906540A1301

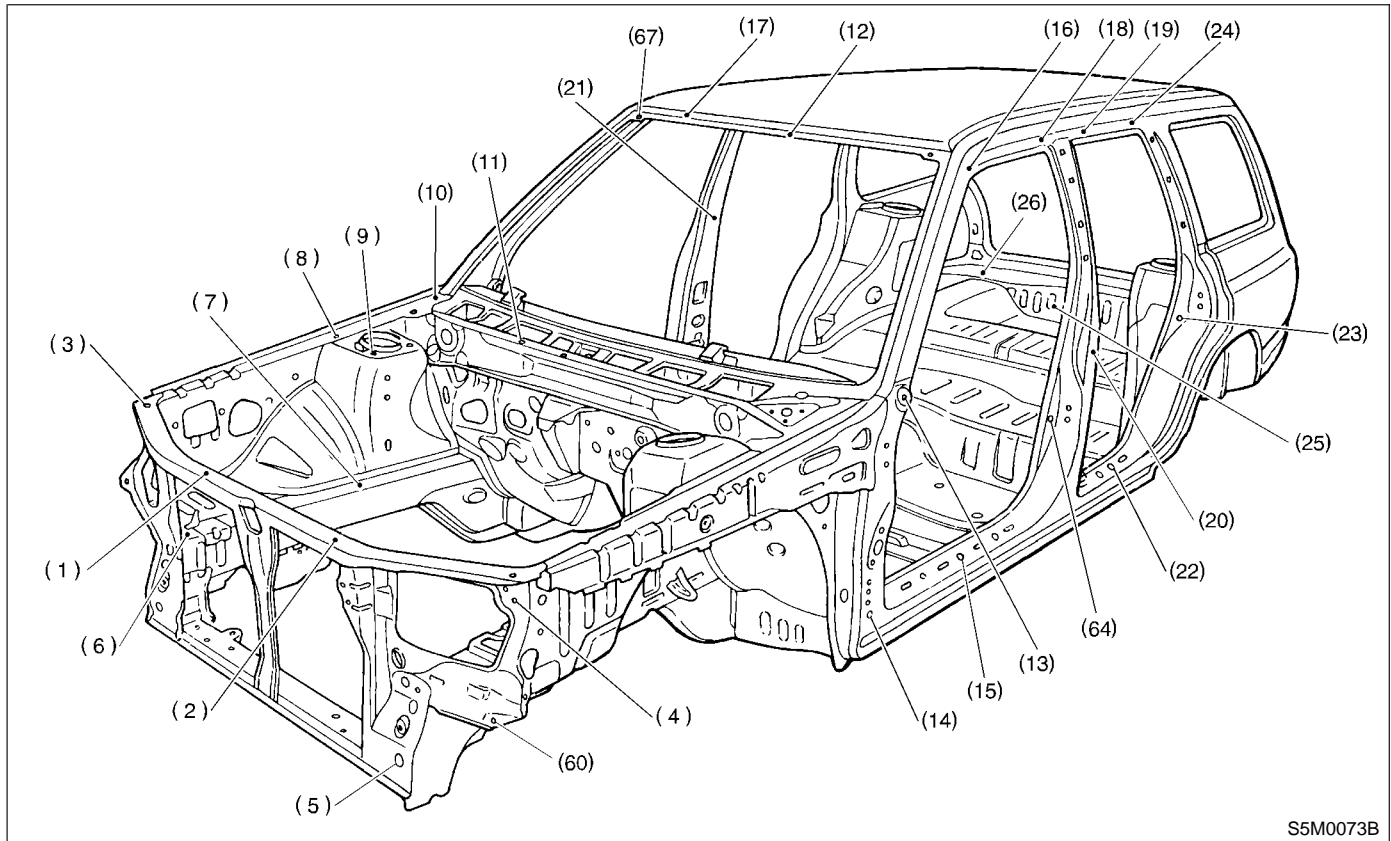

- | | | |
|---|--|--|
| (1) Radiator panel (UPR) repair bolt hole M8 (Right) | (10) Hood hinge attaching bolt hole M8 (Symmetrical) | (20) Center pillar gauge hole 12 mm (0.47 in) dia. (Symmetrical) |
| (2) Radiator panel (UPR) repair bolt hole M8 (Left) | (11) Cowl panel mounting hole 6 mm (0.24 in) dia. (Symmetrical) | (21) Belt anchor attaching bolt hole 11.1 mm (7/16 in) dia. (Symmetrical) |
| (3) Fender attaching bolt hole M6 (Symmetrical) | (12) Roof inner trim attaching bolt hole 8 mm (0.31 in) dia. | (22) Wax coat hole, 20 mm (0.79 in) dia. (Symmetrical) |
| (4) Repair locator 8 mm (0.31 in) dia. (Symmetrical) | (13) Fender attaching bolt hole M6 (Symmetrical) | (23) Rear door switch attaching hole 20 mm (0.79 in) dia. (Symmetrical) |
| (5) Radiator panel side gauge hole 24 mm (0.94 in) dia. (Symmetrical) | (14) Front pillar gauge hole 20 mm (0.79 in) dia. (Symmetrical) | (24) Retainer attaching square hole 7 mm (0.28 in) (Symmetrical) |
| (6) Front bumper mounting hole 14 x 16 mm (0.55 x 0.63 in) dia. (Symmetrical) | (15) Wax coat hole 20 mm (0.79 in) dia. (Symmetrical) | (25) Spare tire attaching bolt hole M8 |
| (7) Front crossmember attaching bolt hole 12.4 mm (0.488 in) dia. (Symmetrical) | (16) Retainer attaching square hole 7 mm (0.28 in) (Symmetrical) | (26) Air draw hole 7 mm (0.28 in) dia. (Symmetrical) |
| (8) Fender attaching bolt hole M6 (Symmetrical) | (17) Sun visor attaching hole 17 mm (0.67 in) dia. (Symmetrical) | (60) Fender attaching bolt hole M6 (Symmetrical) |
| (9) Front strut mounting hole 9.5 mm (0.374 in) dia. (Symmetrical) | (18) Retainer attaching square hole 7 mm (0.28 in) (Symmetrical) | (64) Door switch attaching hole 13.5 mm (0.531 in) dia. (Symmetrical) |
| | (19) Retainer attaching square hole 7 mm (0.28 in) (Symmetrical) | (67) Front glass attaching hole Right 6.5 mm (0.256 in) dia. Left 6.5 x 10 mm (0.256 x 0.39 in) dia. |

2. REAR SECTION S906540A1302

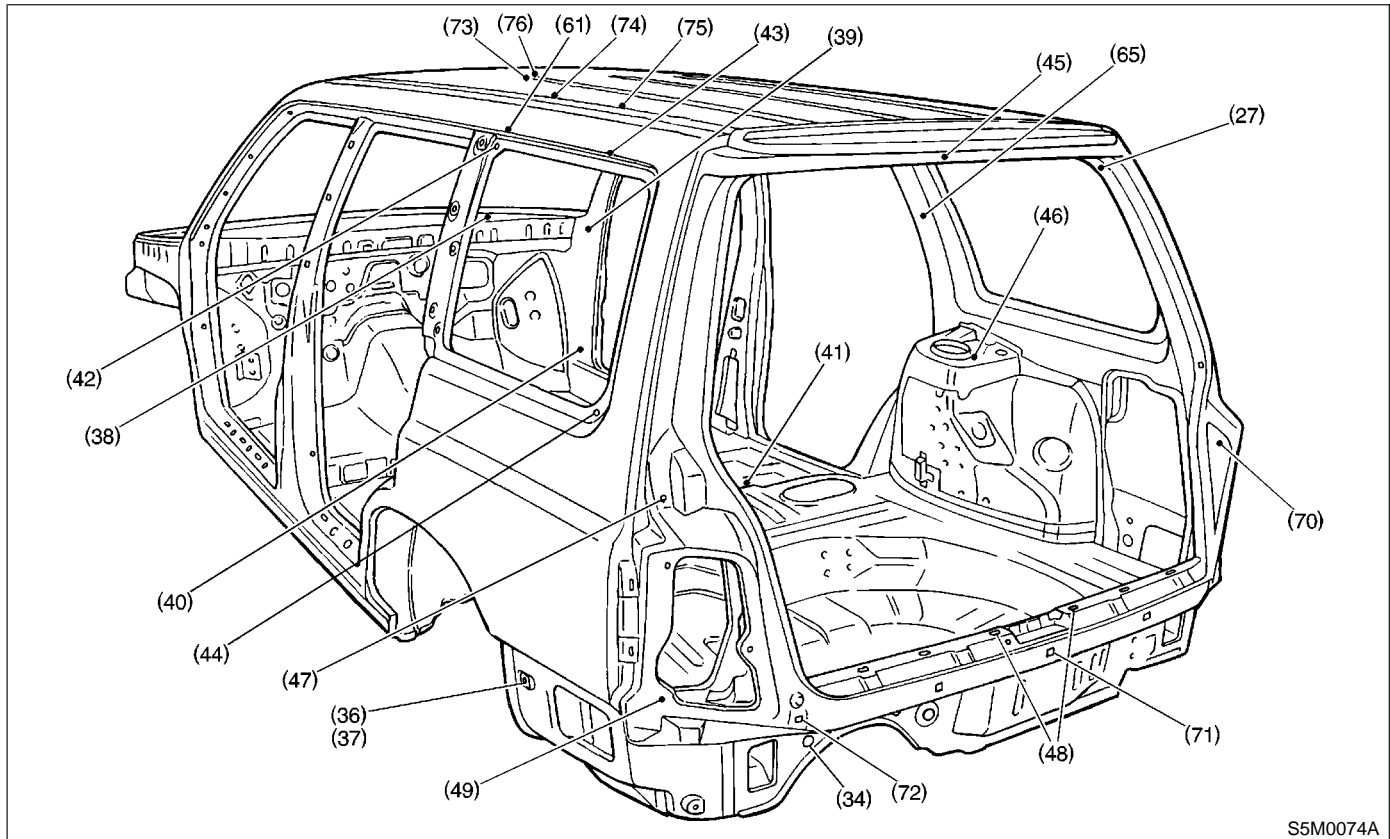

- | | | |
|---|---|--|
| (27) Rear pillar (Inner) harness and hose clip attaching hole 7 mm (0.28 in) dia. (Symmetrical) | (43) Pad attaching square hole 9 mm (0.35 in) dia. (Symmetrical) | (70) Buffer attaching hole M6 (Symmetrical) |
| (34) Rear skirt gauge hole 20 mm (0.79 in) dia. (Symmetrical) | (44) Rear quarter glass attaching hole 8 mm (0.31 in) dia. (Symmetrical) | (71) Bumper face attaching square hole 8 × 9 mm (0.31 × 0.35 in) |
| (36) Rear quarter bumper side gauge hole 20 mm (0.79 in) dia. (Left) | (45) Rear locator hollow 4 mm (0.16 in) dia. | (72) Bumper face attaching square hole 8 × 9 mm (0.31 × 0.35 in) (Symmetrical) |
| (37) Rear quarter bumper side gauge hole 20 mm (0.79 in) dia. (Right) | (46) Rear strut mounting hole 10 mm (0.39 in) dia. (Symmetrical) | (73) Head console bracket gauge hole 8 mm (0.31 in) dia. |
| (38) Instrument panel attaching square hole 22 × 34.5 mm (0.87 × 1.358 in) (Right) | (47) Rear gate stay attaching bolt hole M8 (Symmetrical) | (74) Inner system carrier attaching bolt hole 8 mm (0.31 in) (Symmetrical) |
| (39) Steering support beam attaching bolt hole M8 (Symmetrical) | (48) Inner trim clip attaching hole 8 × 20 mm (0.31 × 0.79 in) dia. (Symmetrical) | (75) Inner system carrier attaching bolt hole 8 mm (0.31 in) (Symmetrical) |
| (40) Front pillar (Inner) gauge hole 10 mm (0.39 in) dia. (Symmetrical) | (49) Rear combination light mounting hole 8 mm (0.31 in) dia. (Symmetrical) | (76) Head console bracket gauge hole 8 mm (0.31 in) dia. |
| (41) Floor mat attaching clip hole 8 mm (0.31 in) dia. (Symmetrical) | (61) Side rail (Inner) gauge hole 10 mm (0.39 in) dia. (Symmetrical) | |
| (42) Rear quarter glass attaching hole 8 × 15 mm (0.31 × 0.59 in) dia. (Symmetrical) | (65) Repair location hole 12 mm (0.47 in) dia. (Symmetrical) | |

DATUM POINTS

Body Structure

3. UNDERBODY SECTION S906540A1303

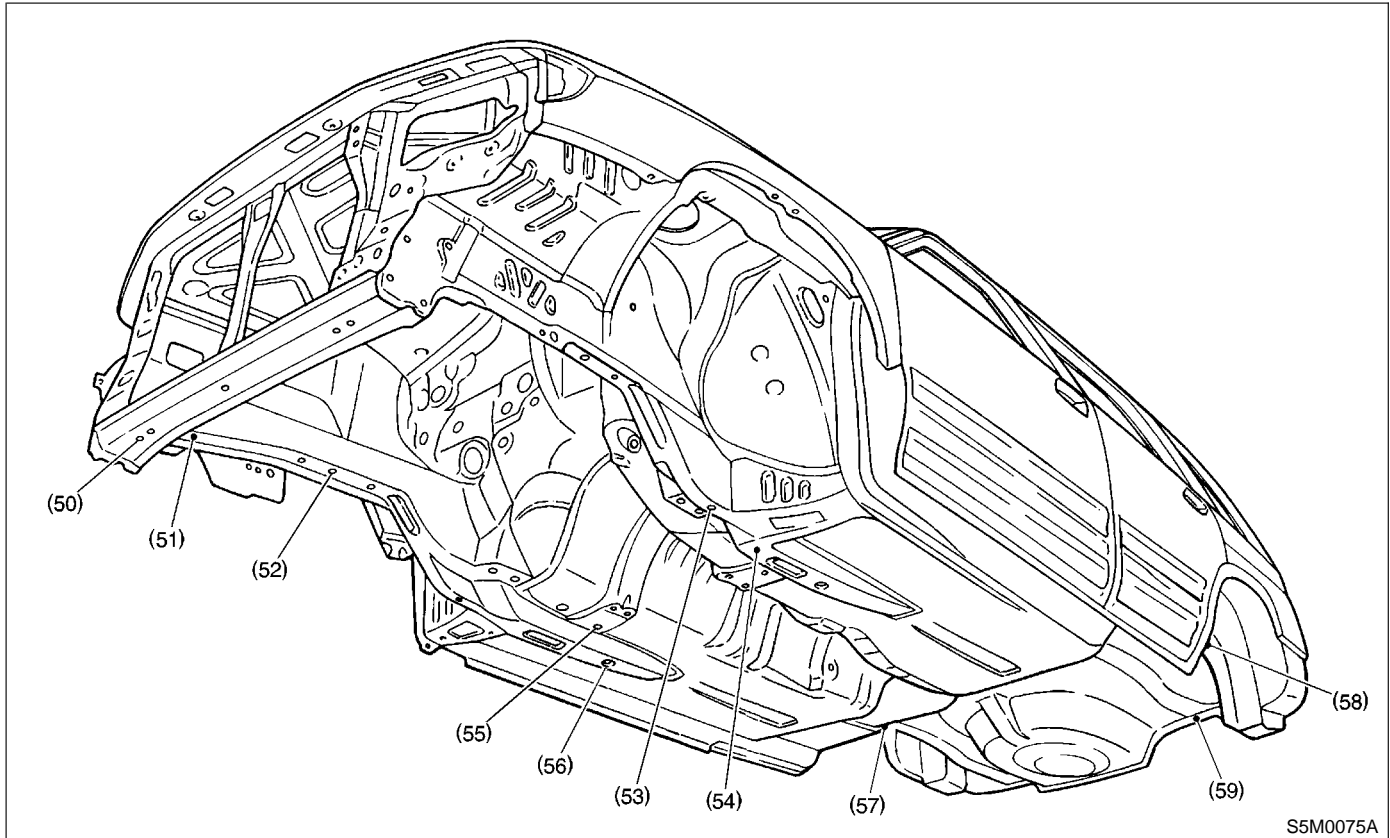

- (50) Radiator panel (LWR) frame gauge hole 15 mm (0.59 in) dia. (Symmetrical)
- (51) Front side frame gauge hole 20 mm (0.79 in) dia. (Symmetrical)
- (52) Front crossmember attaching hole 12.4 mm (0.488 in) dia. (Symmetrical)

- (53) Front suspension attaching bolt hole M14
- (54) Side frame gauge hole 20 mm (0.79 in) dia. (Symmetrical)
- (55) Repair location hole 12 mm (0.47 in) dia. (Symmetrical)
- (56) Side frame gauge hole 15 mm (0.59 in) dia. (Symmetrical)

- (57) Rear differential attaching bolt hole M12 (Symmetrical)
- (58) Rear suspension attaching bolt hole M12 (Symmetrical)
- (59) Rear side frame gauge hole 15 mm (0.59 in) dia. (Symmetrical)

DATUM POINTS

Body Structure

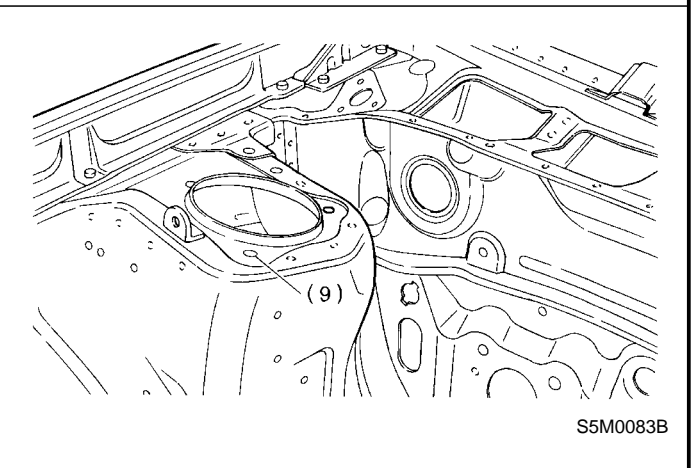
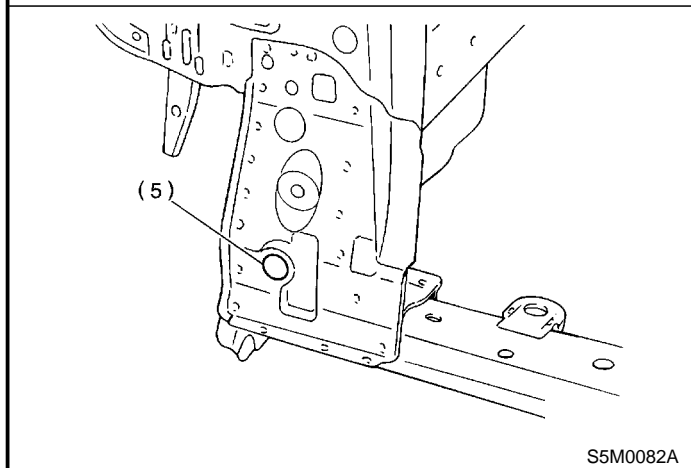
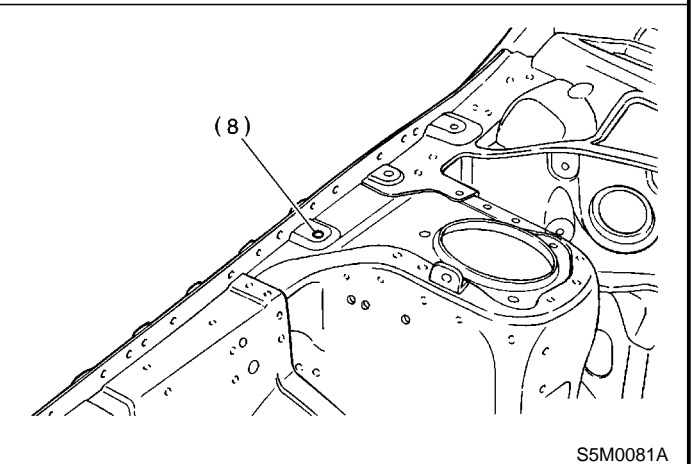
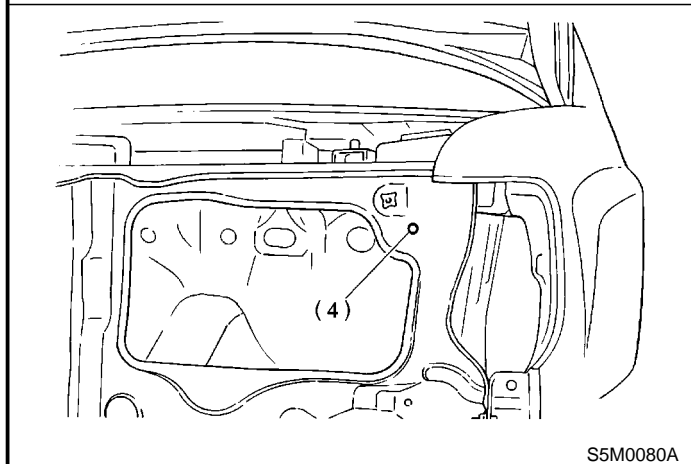
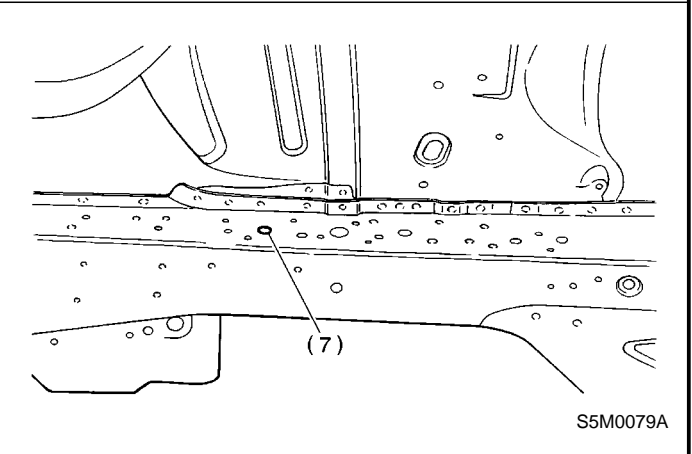
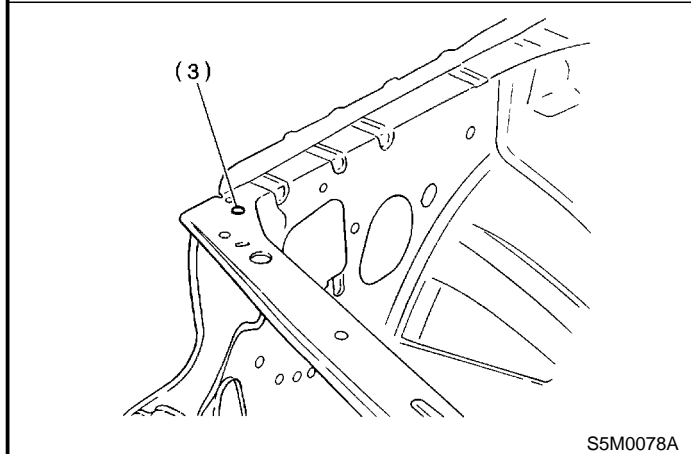
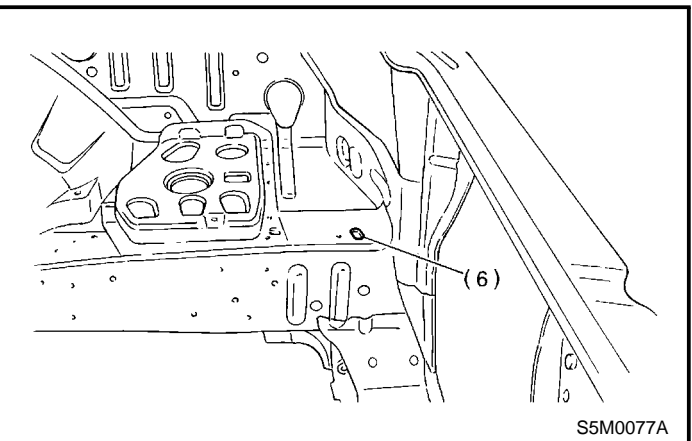
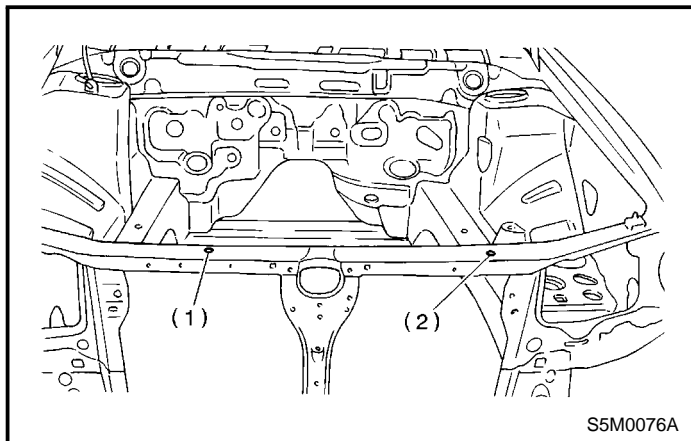

DATUM POINTS

Body Structure

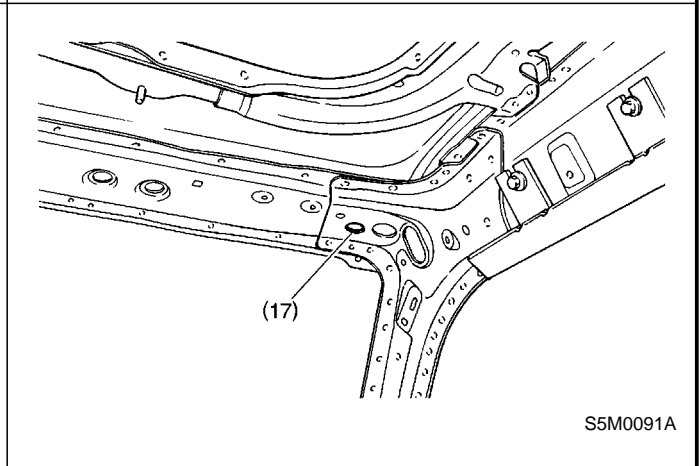
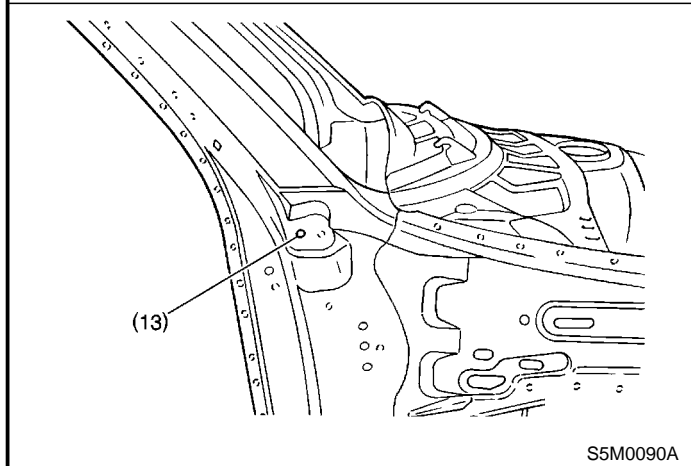
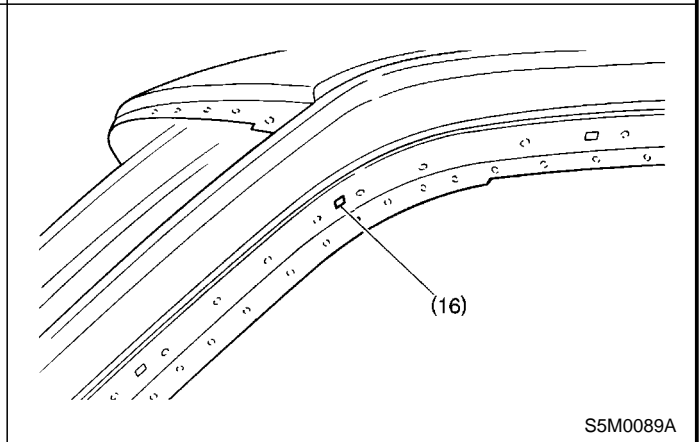
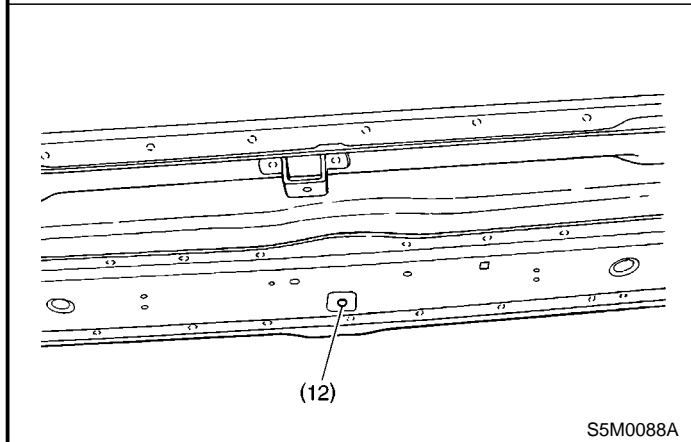
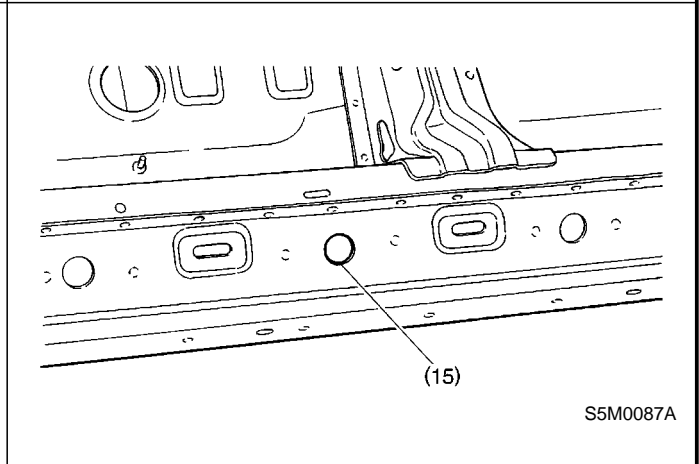
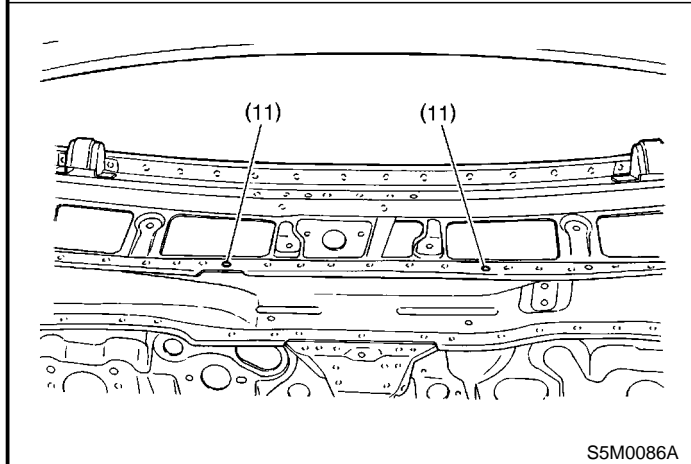
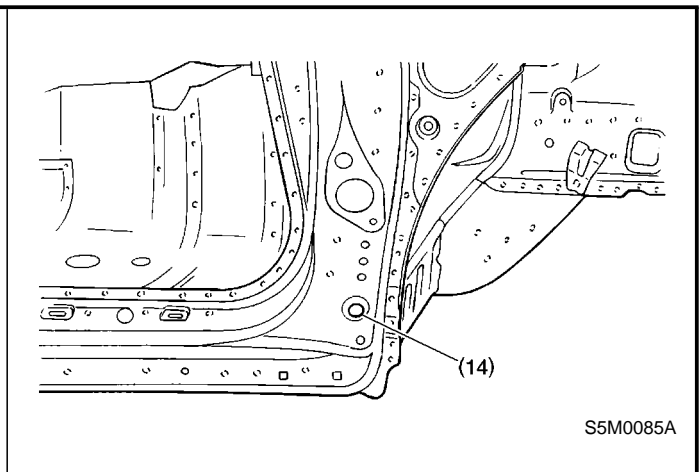
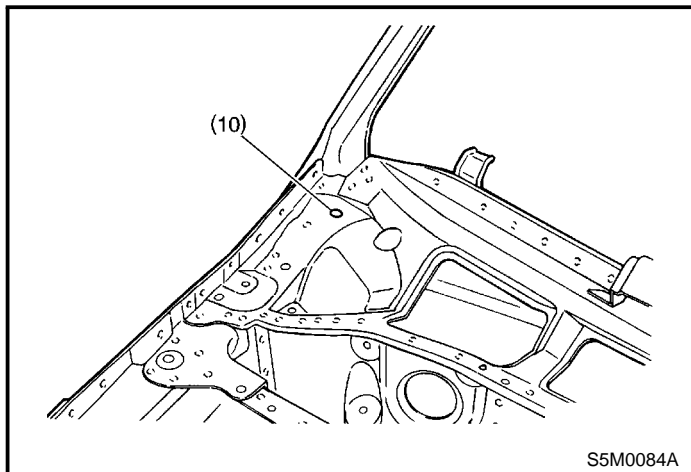

DATUM POINTS

Body Structure

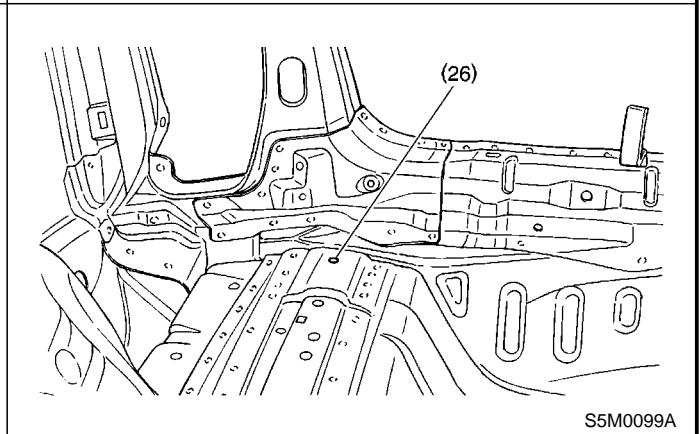
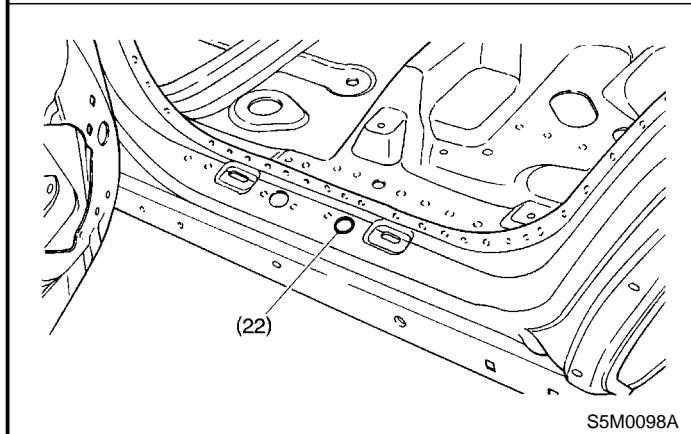
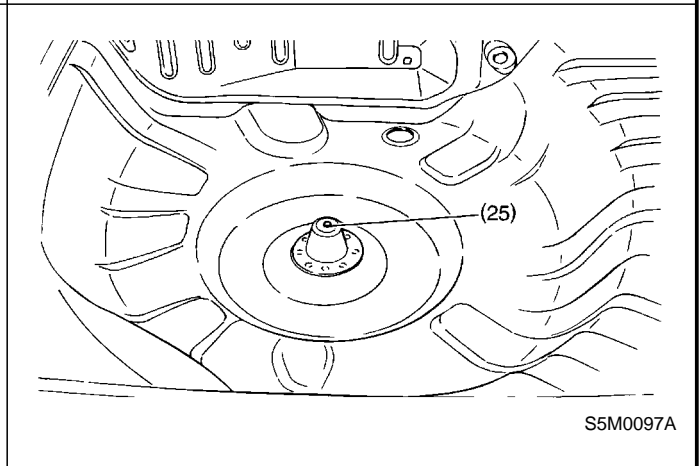
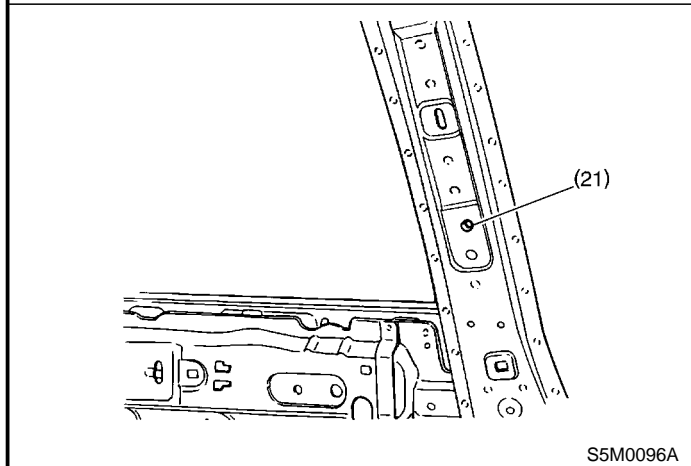
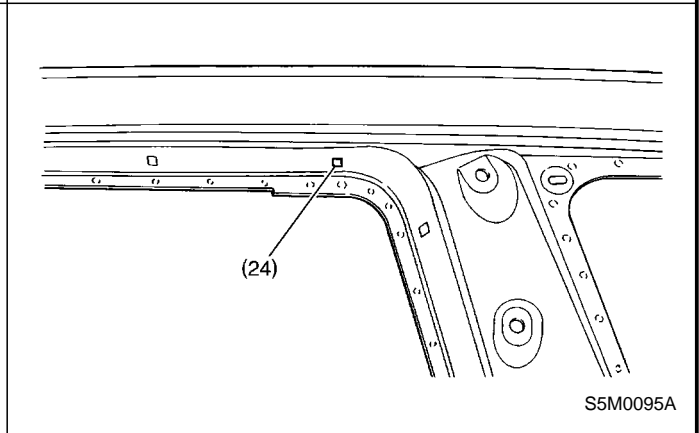
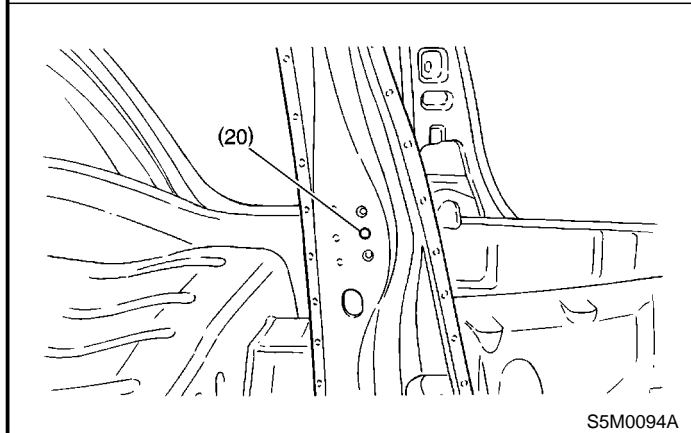
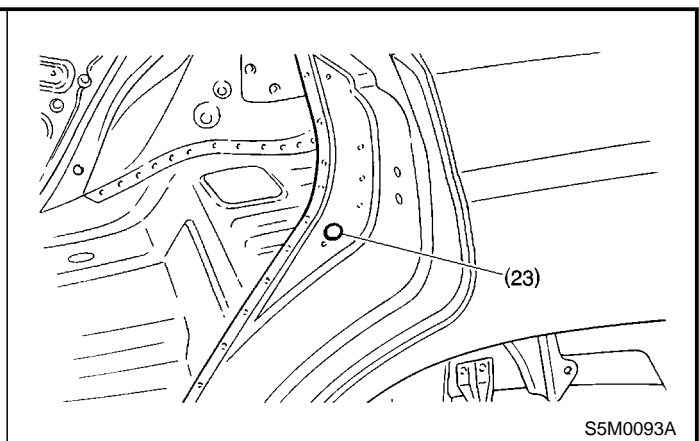
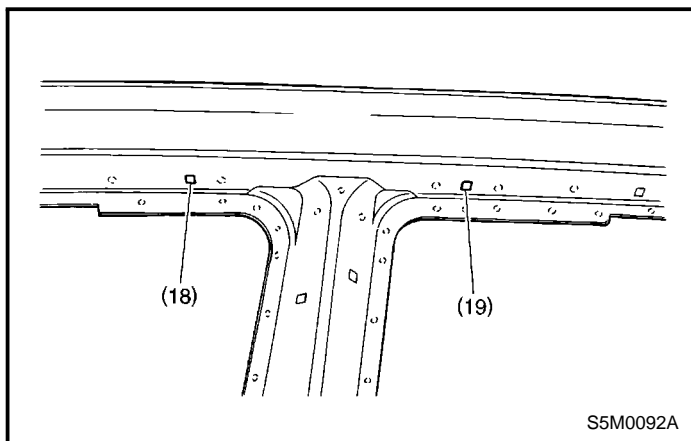

DATUM POINTS

Body Structure

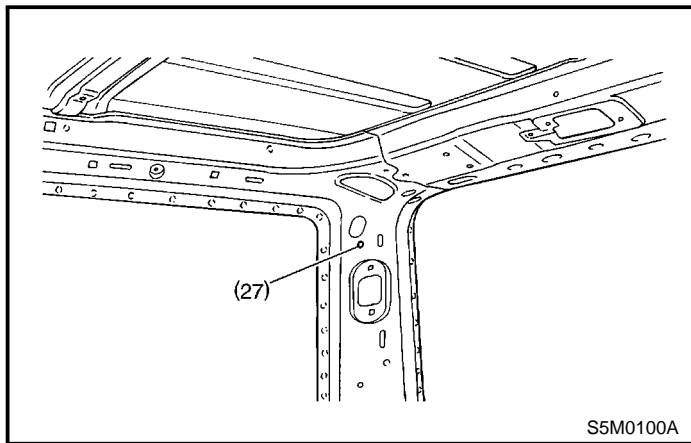

S5M0100A

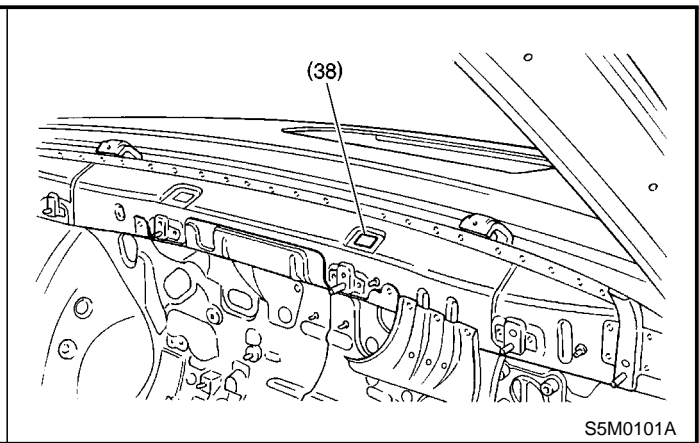

S5M0101A

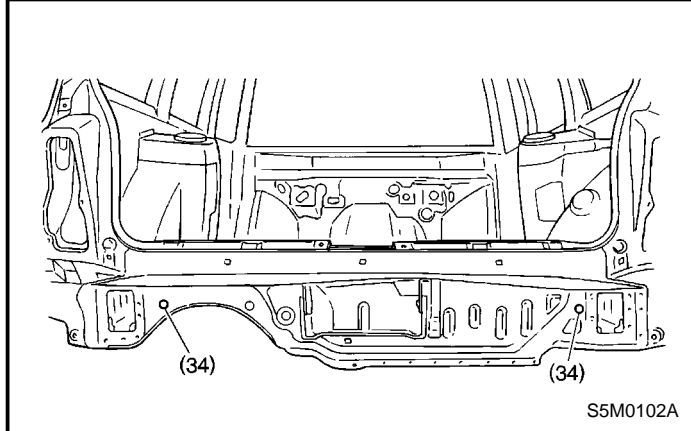

S5M0102A

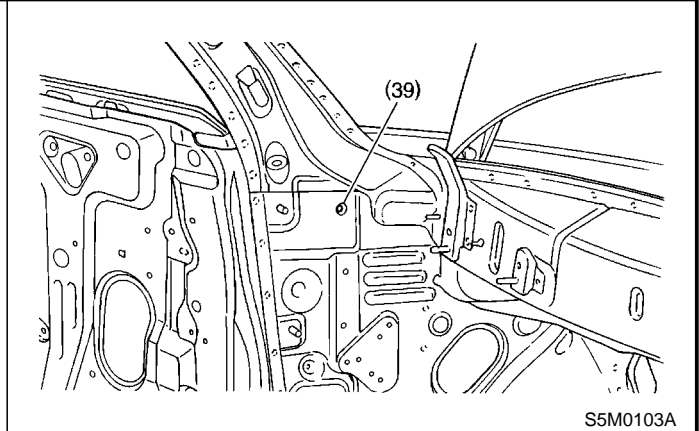

S5M0103A

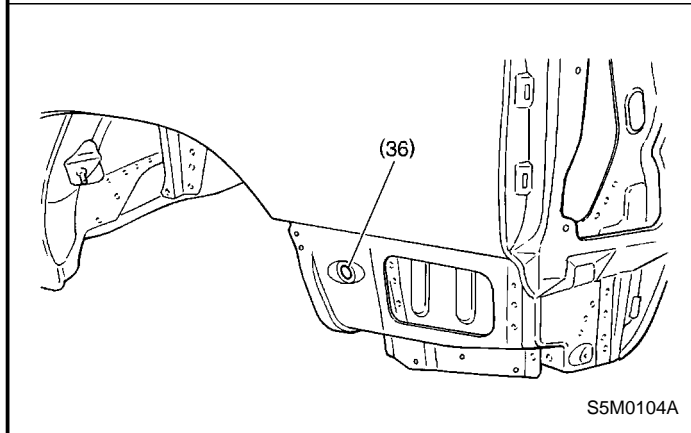

S5M0104A

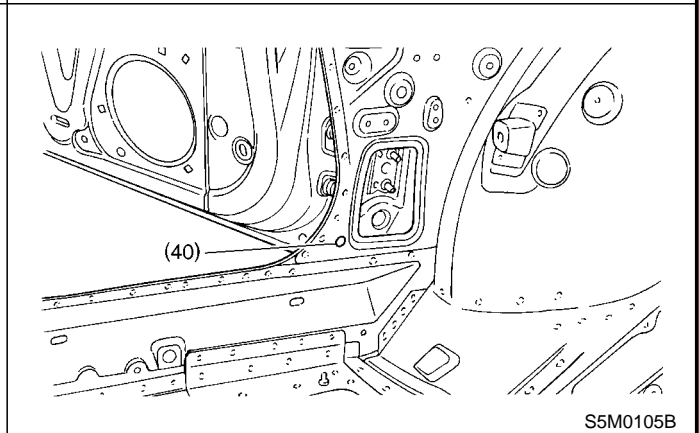

S5M0105B

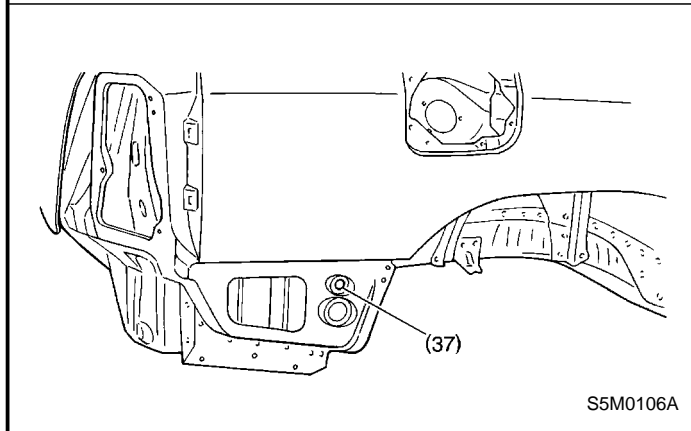

S5M0106A

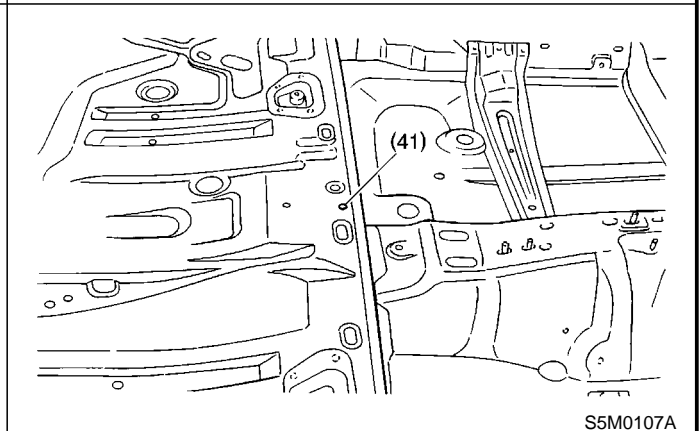

S5M0107A

DATUM POINTS

Body Structure

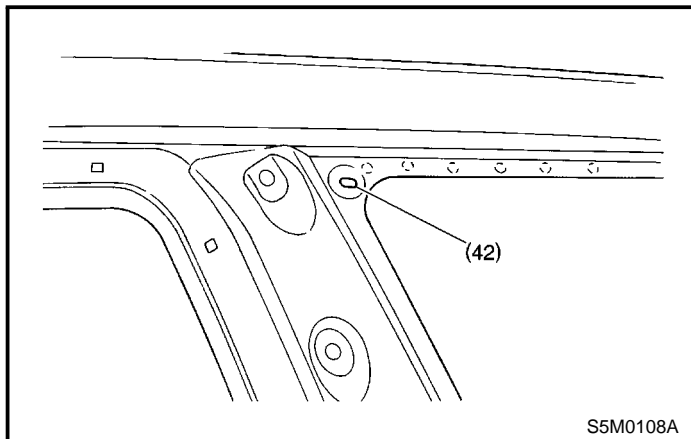

S5M0108A

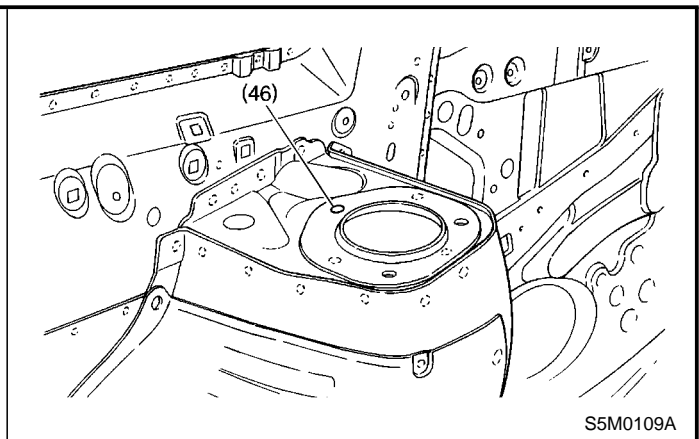

S5M0109A

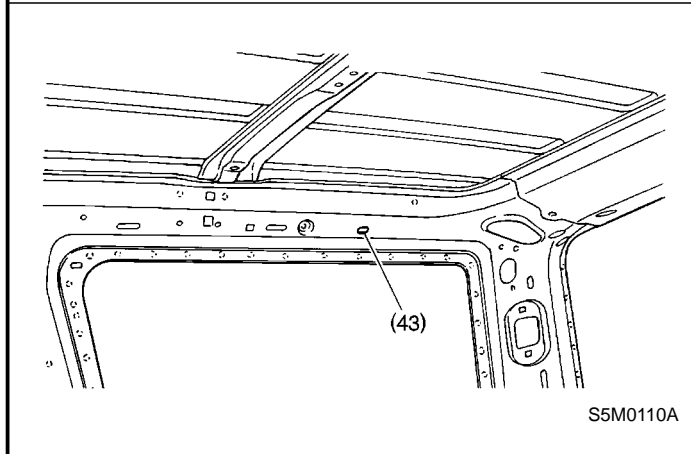

S5M0110A

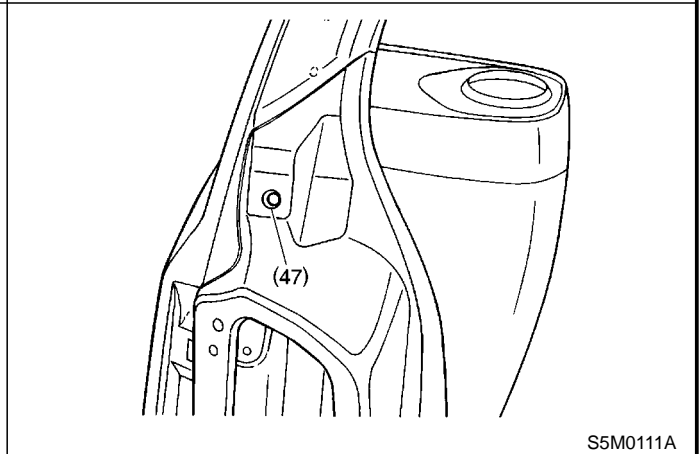

S5M0111A

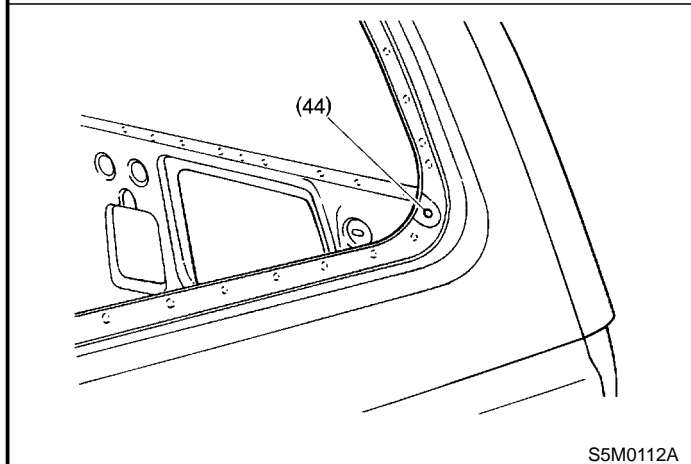

S5M0112A

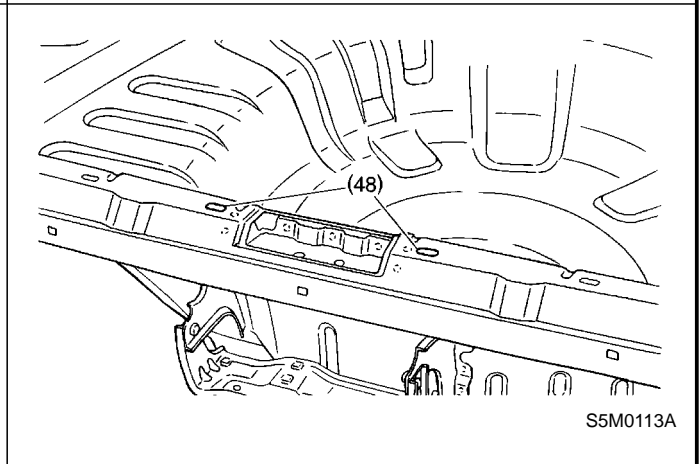

S5M0113A

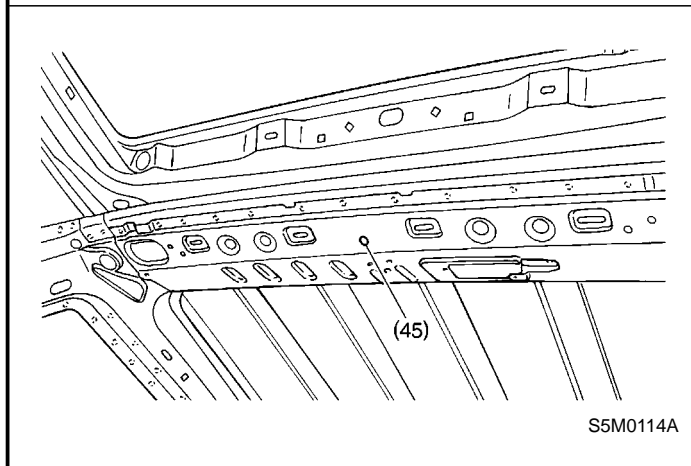

S5M0114A

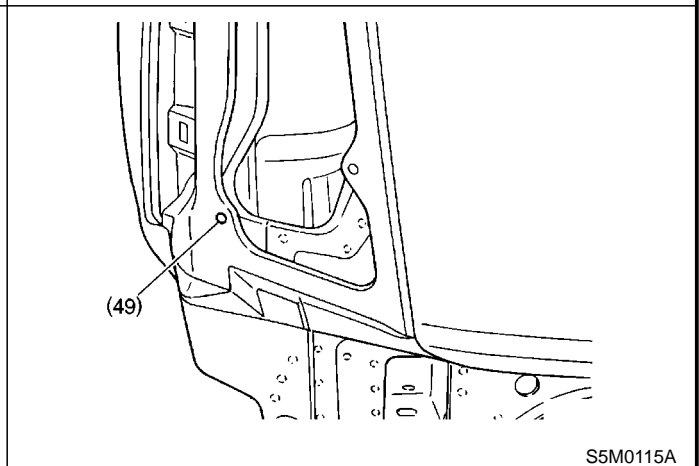

S5M0115A

DATUM POINTS

Body Structure

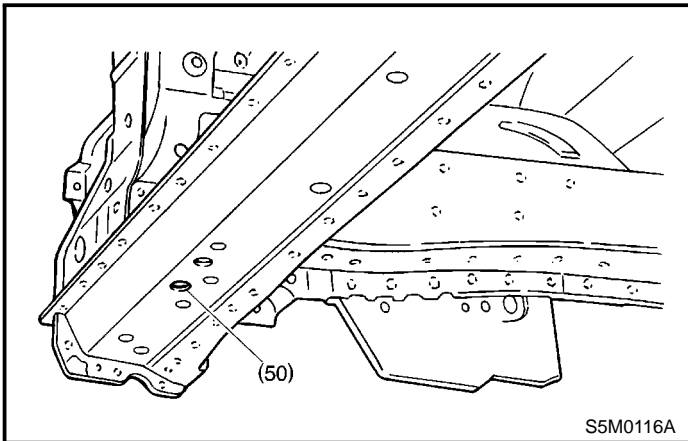

S5M0116A

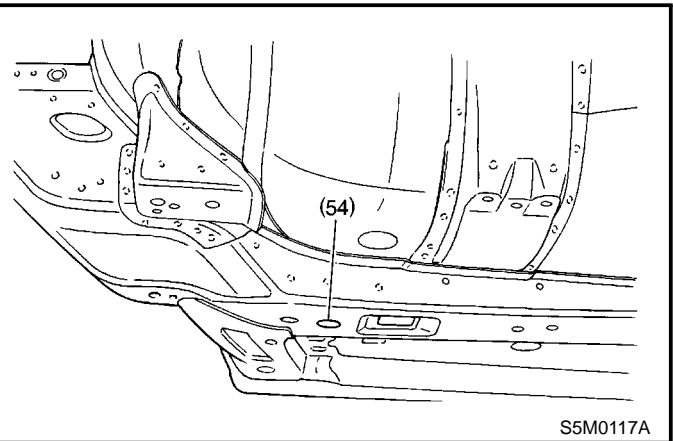

S5M0117A

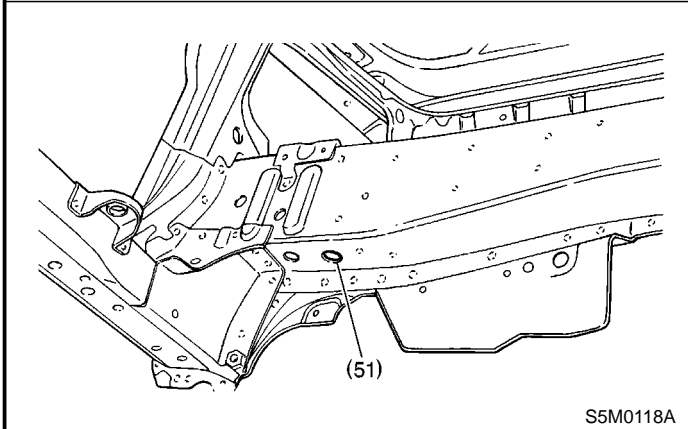

S5M0118A

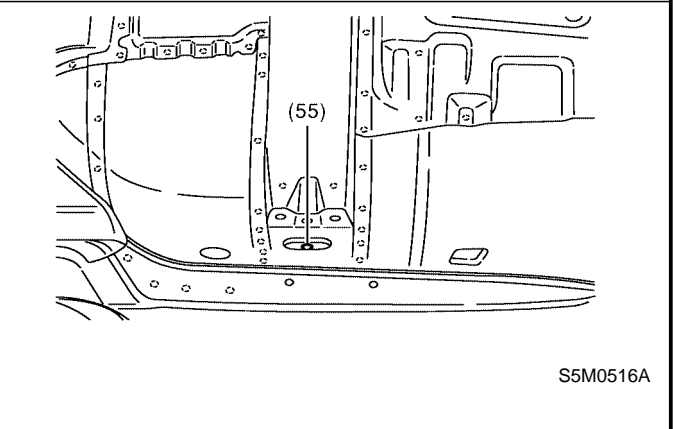

S5M0516A

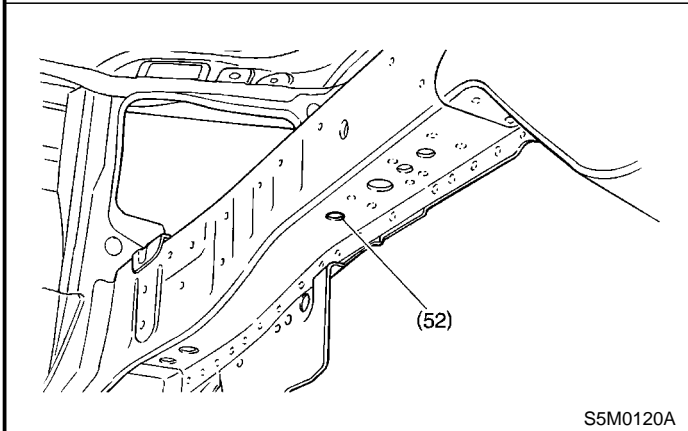

S5M0120A

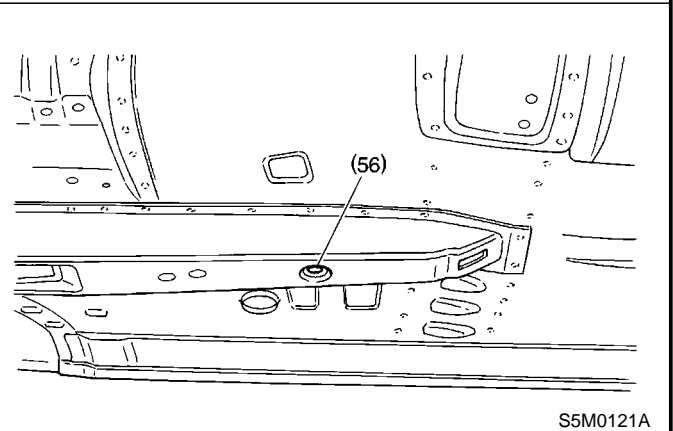

S5M0121A

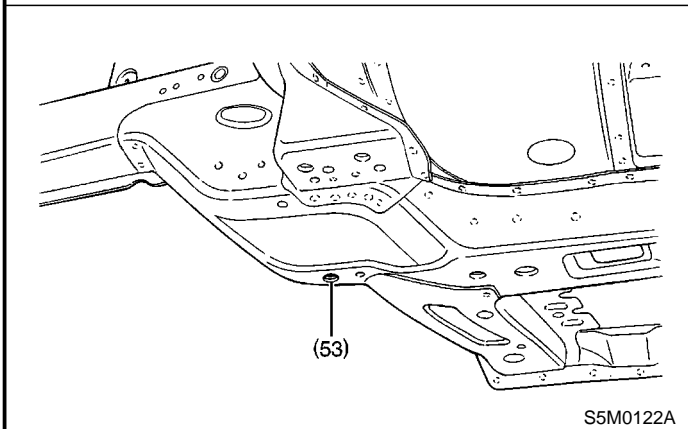

S5M0122A

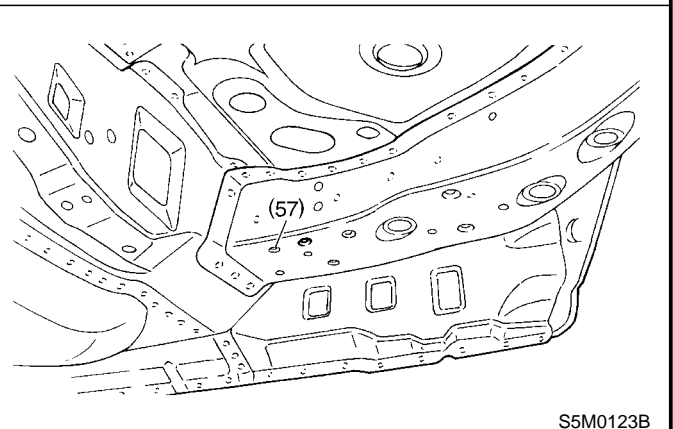

S5M0123B

DATUM POINTS

Body Structure

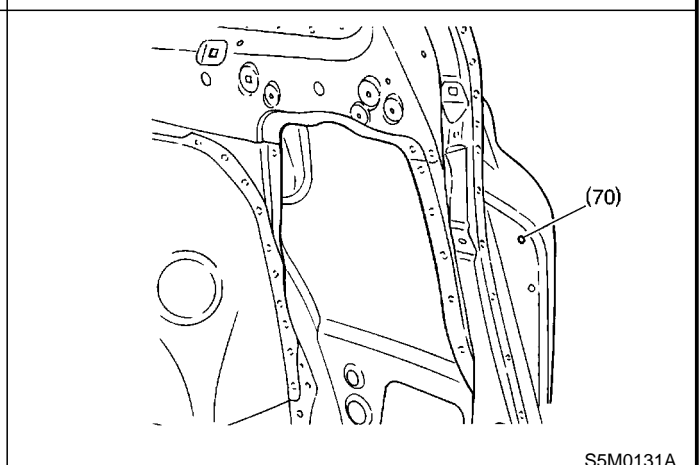
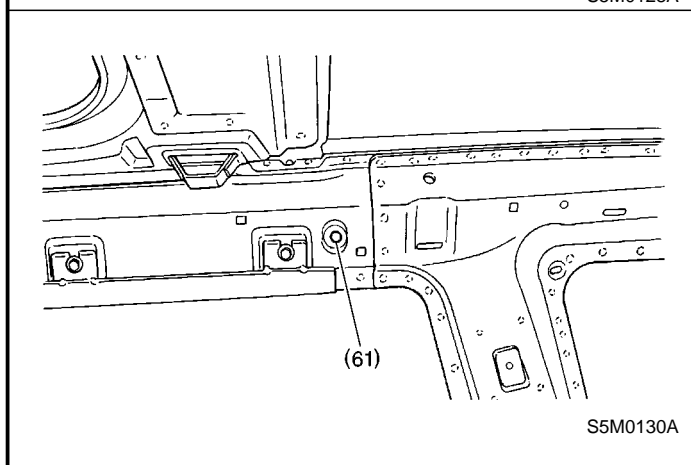
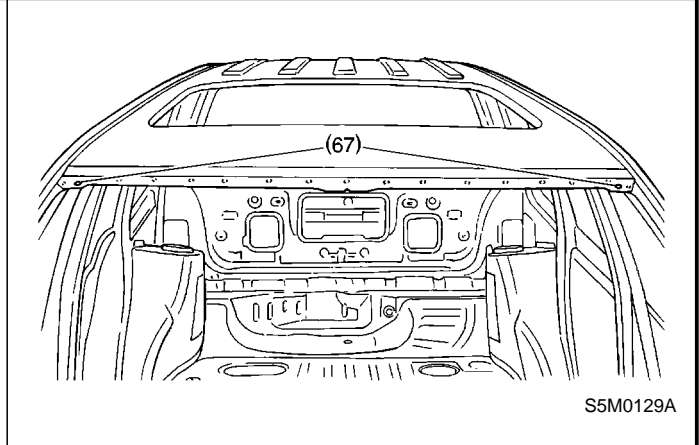
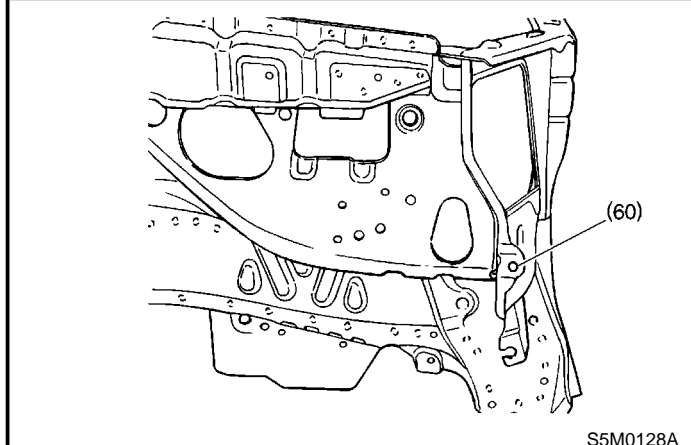
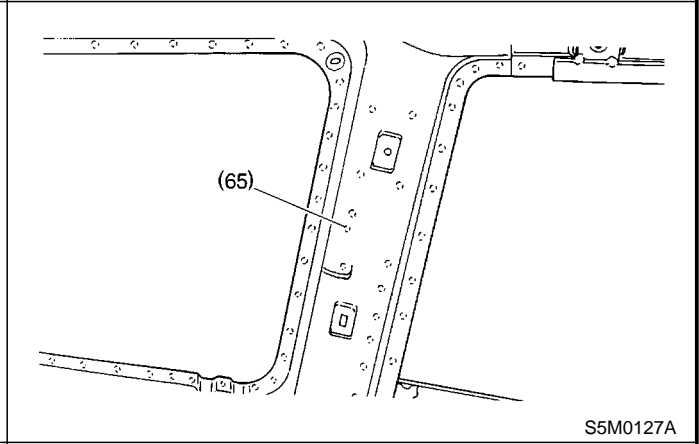
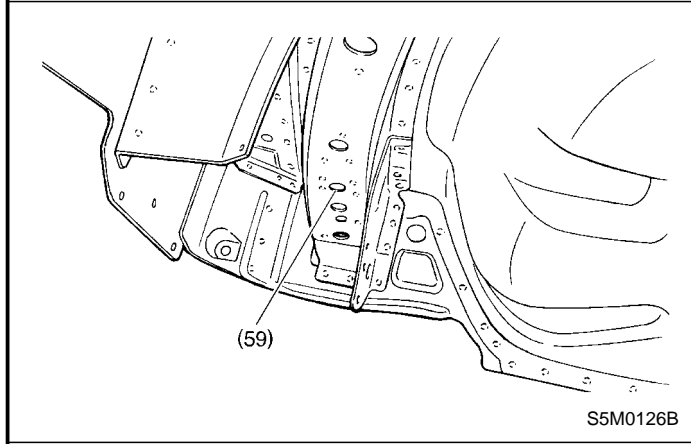
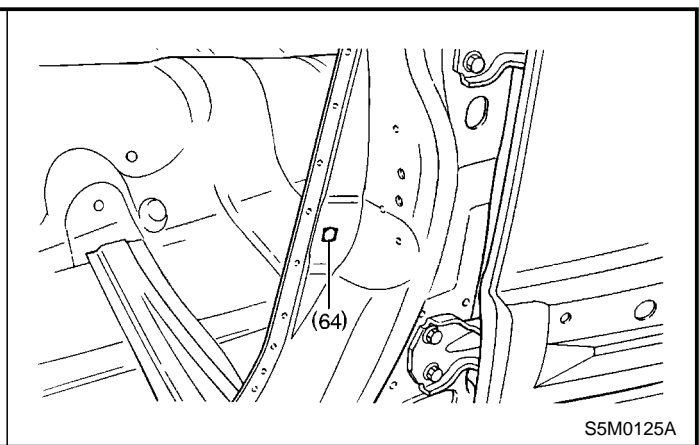
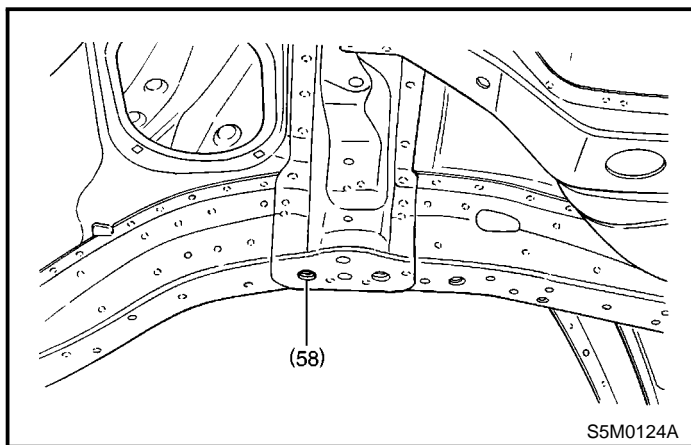

DATUM POINTS

Body Structure

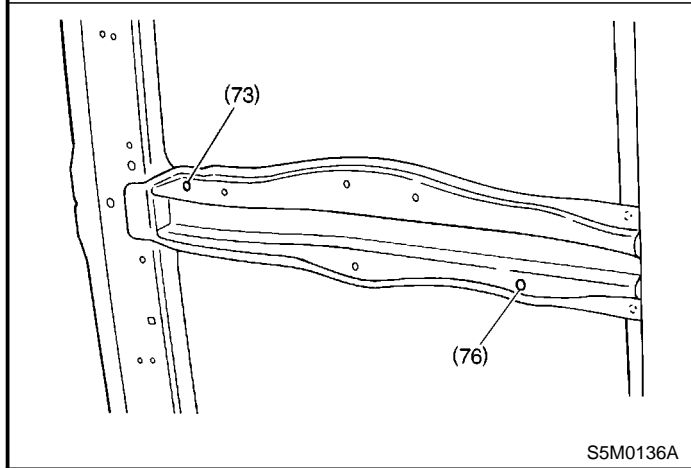
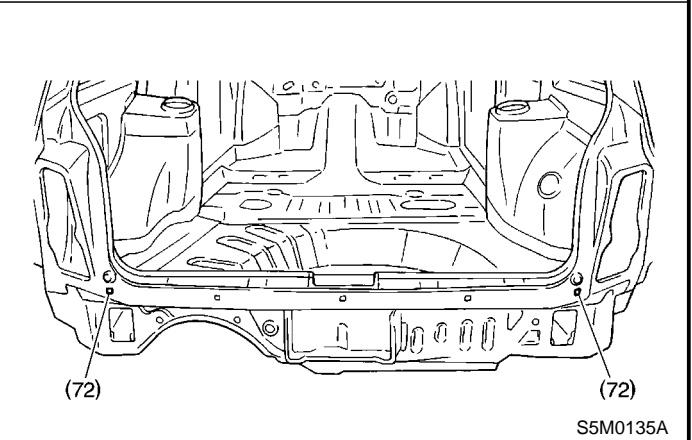
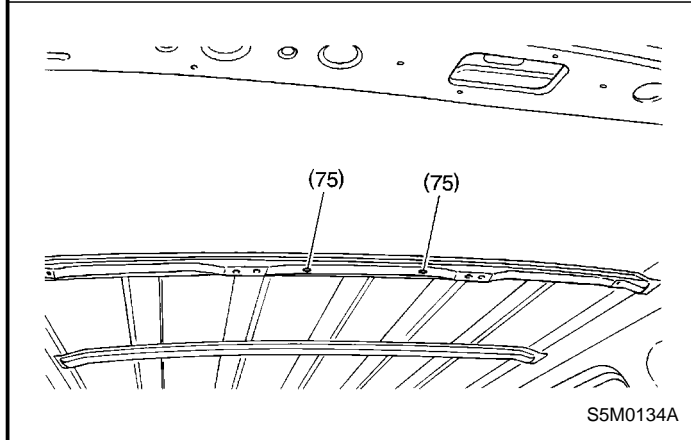
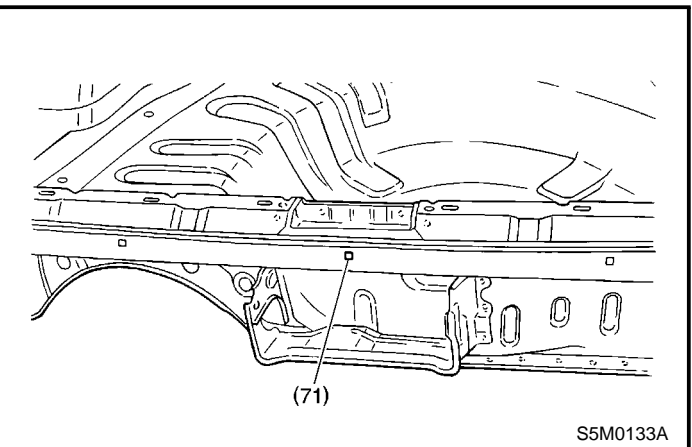
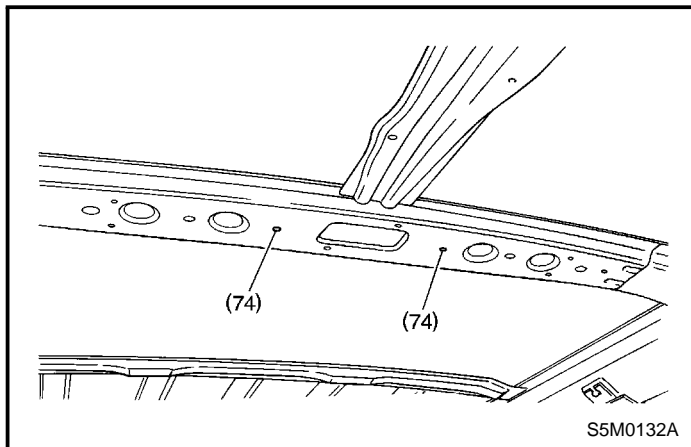

3. Datum Dimensions S906337

A: MEASUREMENT S906337A14

Refer to LOCATION for details on measurement points. <Ref. to BS-3, LOCATION, Datum Points.>

NOTE:

- Using a tram tracking gauge, measure all the dimensions.
- When using a tape measure, carefully measure dimensions without letting the tape measure sag or twist.
- Measure the linear dimensions between CENTERS of holes.
- Suffixes "RH" and "LH" indicate right-hand and left-hand.

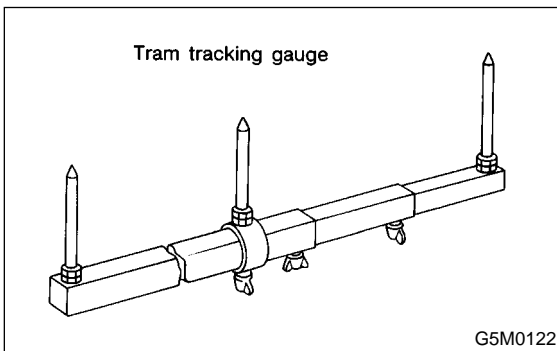

- Measure at the center of the circle around the outside of the body panel.

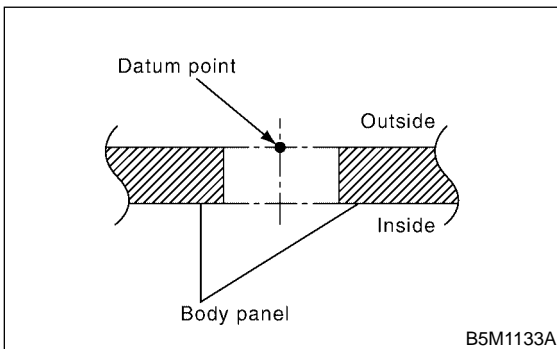

DATUM DIMENSIONS

Body Structure

1. FRONT STRUCTURE S906337A1401

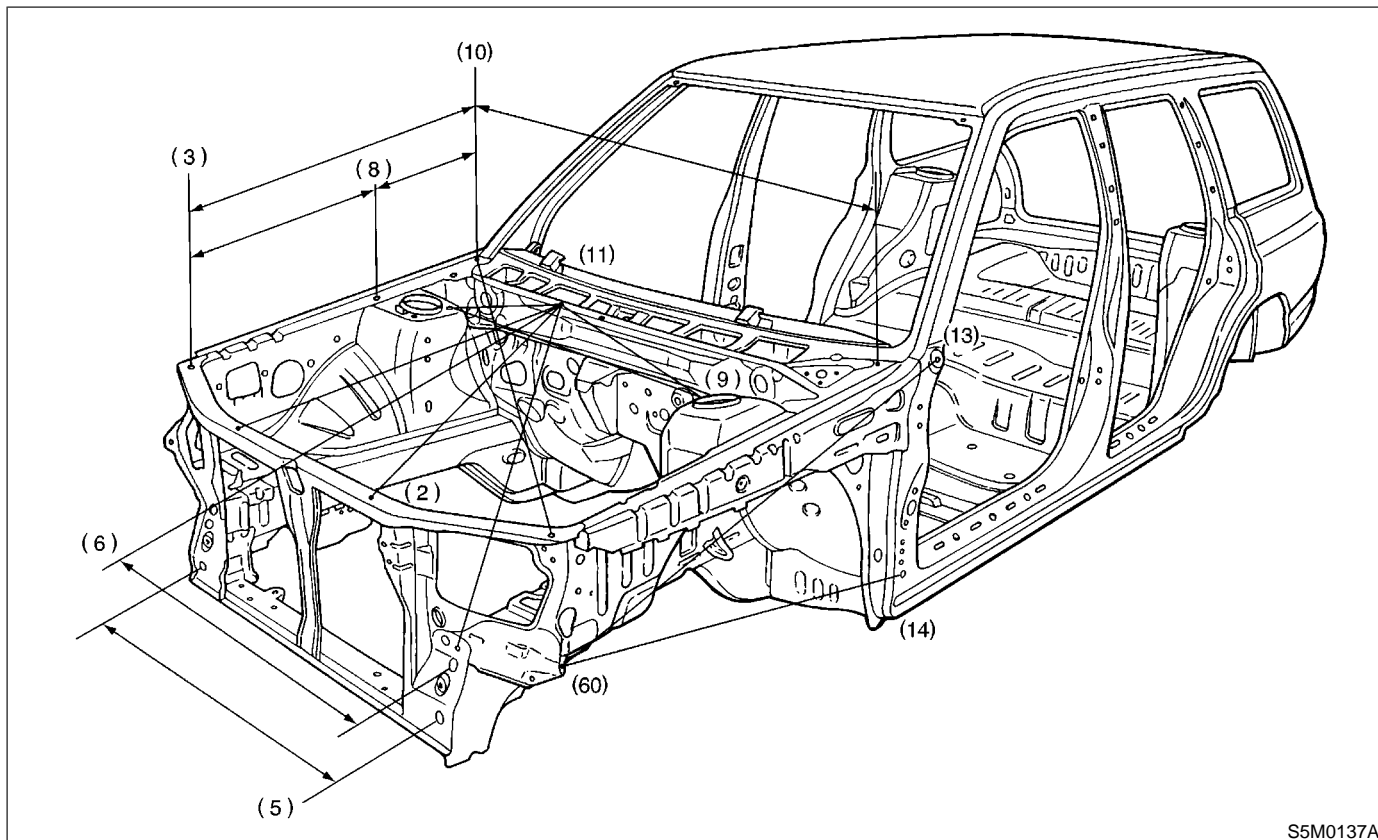

S5M0137A

		Unit: mm (in)	
Point to point	Dimension	Point to point	Dimension
(11) R to (1)	852 (33.54)	(10) R to (8) R	390 (15.35)
(11) L to (1)	913 (35.94)	(10) L to (8) L	390 (15.35)
(11) R to (2)	960 (37.80)	(11) L to (9) R	659 (25.94)
(11) L to (2)	865 (34.06)	(11) R to (9) L	659 (25.94)
(11) R to (9) R	392 (15.43)	(9) R to (9) L	966 (38.03)
(11) L to (9) L	392 (15.43)	(11) L to (6) R	1,059 (41.69)
(11) R to (6) R	926 (36.46)	(11) R to (6) L	1,059 (41.69)
(11) L to (6) L	926 (36.46)	(6) R to (6) L	914 (35.98)
(11) R to (3) R	891 (35.08)	(6) R to (10) L	1,549 (60.98)
(11) L to (3) L	891 (35.08)	(6) L to (10) R	1,549 (60.98)
(10) R to (3) R	917 (36.10)	(8) R to (3) R	528 (20.79)
(10) L to (3) L	917 (36.10)	(8) L to (3) L	528 (20.79)
(10) R to (10) L	1,374 (54.09)	(10) L to (3) R	1,637 (64.45)
(3) R to (3) L	1,338 (52.68)	(8) R to (8) L	1,396 (54.96)
(5) R to (5) L	924 (36.38)	(8) R to (10) L	1,438 (56.61)
(4) R to (4) L	1,296 (51.02)	(8) L to (10) R	1,438 (56.61)
(5) R to (4) L	1,176 (46.30)	(3) R to (8) L	1,465 (57.68)
(5) L to (4) R	1,176 (46.30)	(3) L to (8) R	1,465 (57.68)
(60) R to (13) R	1,174 (46.22)	(7) R to (7) L	860 (33.86)
(60) L to (13) L	1,174 (46.22)	(7) R to (6) L	982 (38.66)
(60) R to (14) R	1,076 (42.36)	(7) L to (6) R	982 (38.66)
(60) L to (14) L	1,076 (42.36)	(7) R to (10) L	1,302 (51.26)
(10) R to (3) L	1,637 (64.45)	(7) L to (10) R	1,302 (51.26)

DATUM DIMENSIONS

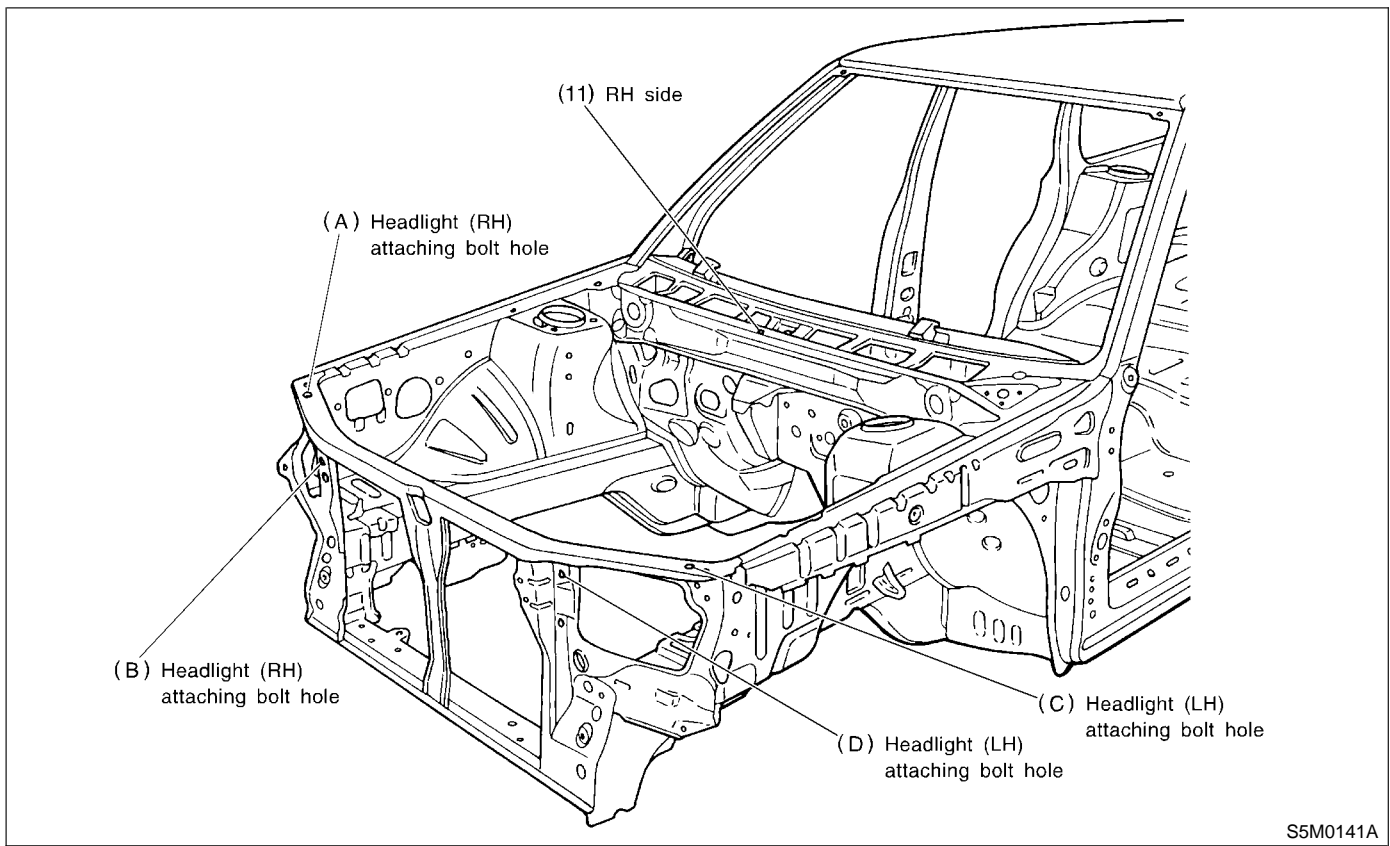

		Unit: mm (in)	
Point to point	Dimension	Point to point	Dimension
(11) to (A)	909.9 (35.82)	(11) to (C)	1,097.7 (43.22)
(11) to (B)	915 (36.02)	(11) to (D)	1,022 (40.24)

DATUM DIMENSIONS

Body Structure

2. CENTER STRUCTURE S906337A1402

Unit: mm (in)

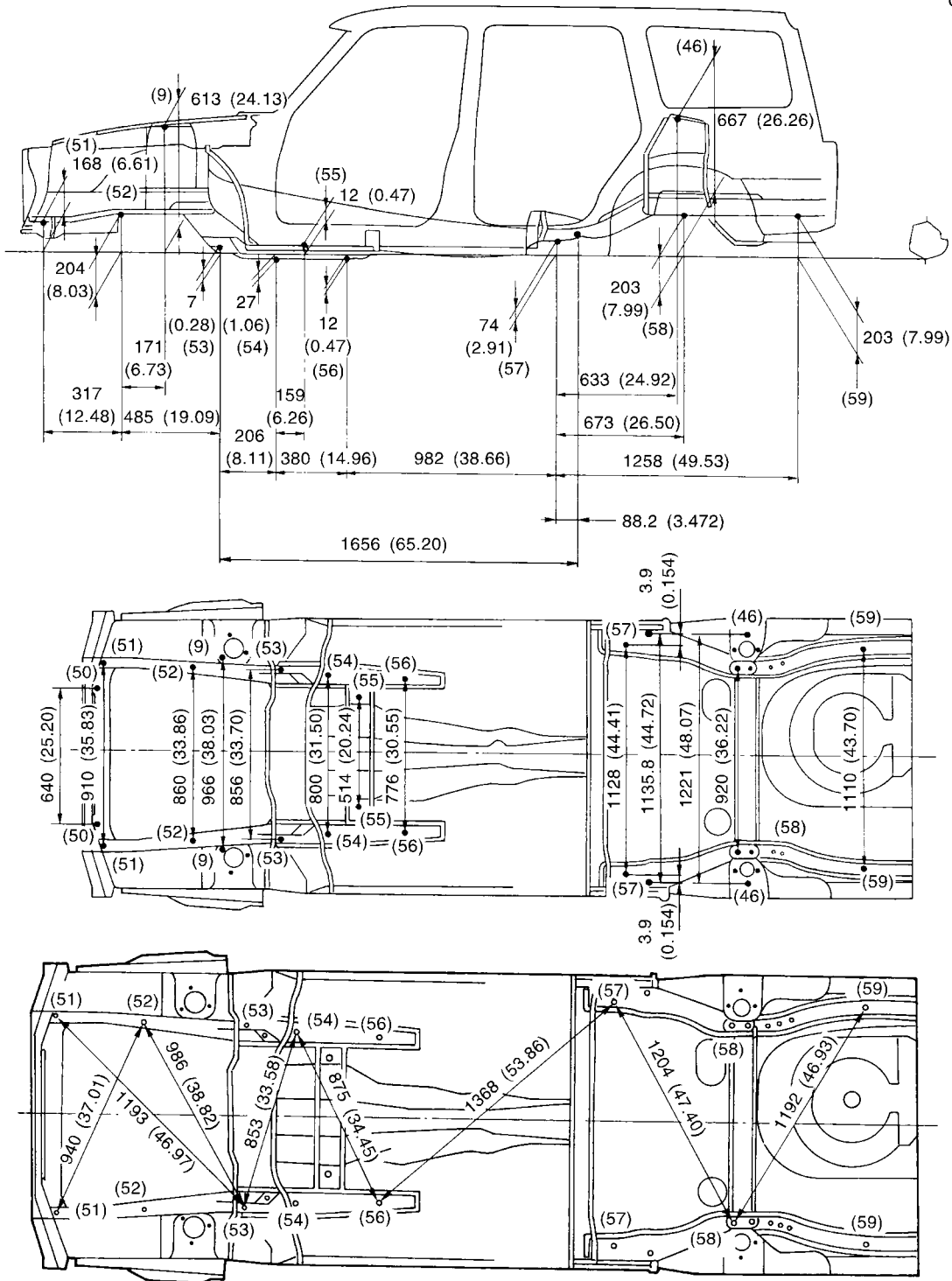

S5M0138B

3. WINDSHIELD AND DOORS S906337A1403

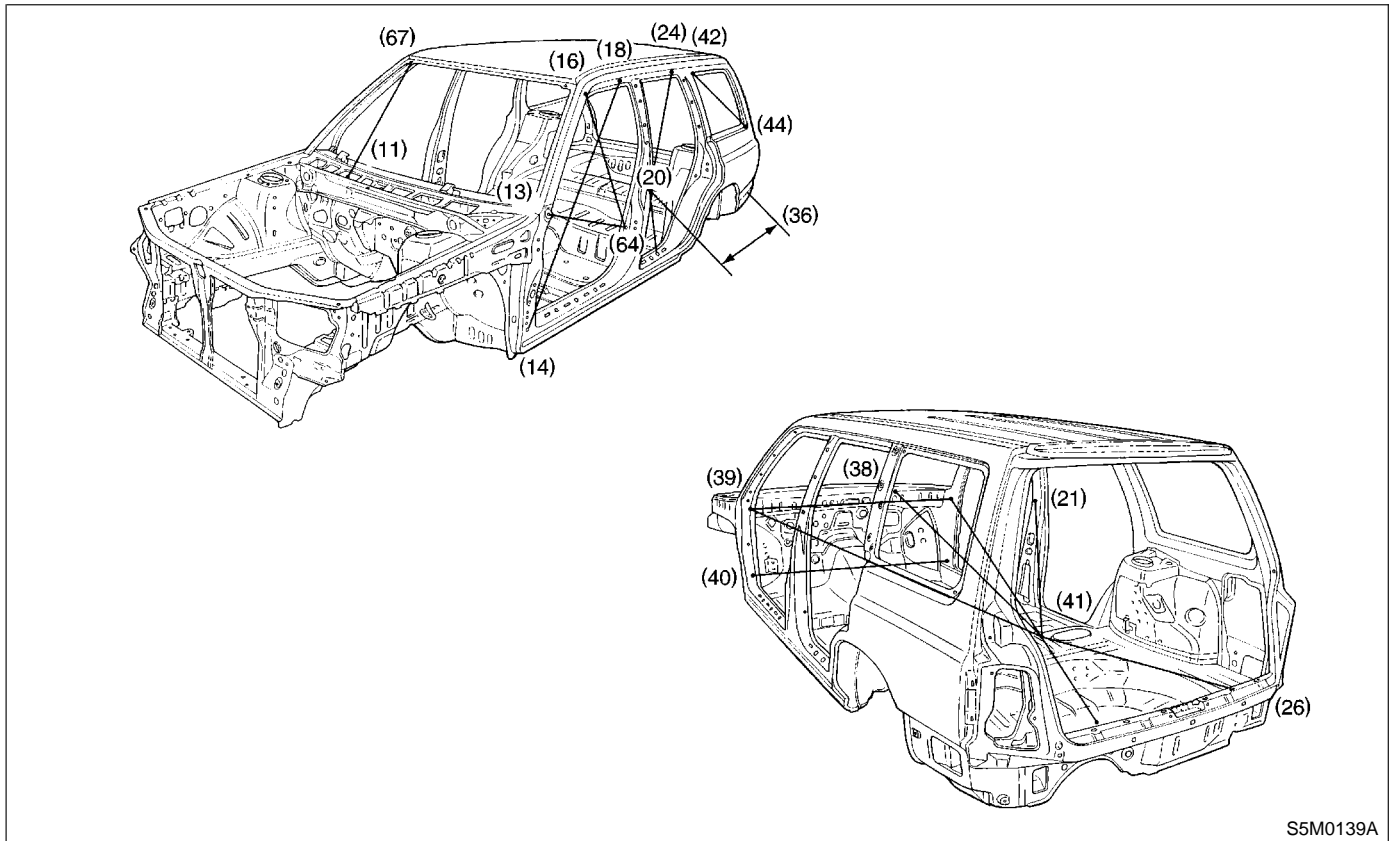

DATUM DIMENSIONS

Body Structure

		Unit: mm (in)	
Point to point	Dimension	Point to point	Dimension
(14) L to (18) L	1,453 (57.20)	(16) L to (64) L	859 (33.82)
(14) R to (18) R	1,453 (57.20)	(16) R to (64) R	859 (33.82)
(13) L to (64) L	944 (37.17)	(20) L to (23) L	845 (33.27)
(13) R to (64) R	944 (37.17)	(20) R to (23) R	845 (33.27)
(20) L to (24) L	947 (37.28)	(19) L to (23) L	885 (34.84)
(20) R to (24) R	947 (37.28)	(19) R to (23) R	885 (34.84)
(20) L to (36)	1,484 (58.43)	(11) L to (67) R	1,147 (45.16)
(20) R to (37)	1,488 (58.58)	(11) R to (67) L	1,147 (45.16)
(42) L to (44) L	769 (30.28)	(41) to (38)	1,157 (45.55)
(42) R to (44) R	769 (30.28)	(41) to (39) R	1,530 (60.24)
(11) R to (12)	918 (36.14)	(41) to (39) L	1,530 (60.24)
(11) L to (12)	918 (36.14)	(41) to (40) R	1,447 (56.97)
(67) R to (67) L	1,045 (41.14)	(41) to (40) L	1,447 (56.97)
(11) R to (67) R	1,006 (39.61)	(41) to (15) R	1,140 (44.88)
(11) L to (67) L	1,006 (39.61)	(41) to (15) L	1,140 (44.88)
(12) to (67) L	525 (20.67)	(41) to (22) R	733 (28.86)
(12) to (67) R	525 (20.67)	(41) to (22) L	733 (28.86)
(12) to (10) L	1,027 (40.43)	(41) to (26) R	1,568 (61.73)
(12) to (10) R	1,027 (40.43)	(41) to (26) L	1,568 (61.73)
(21) R to (21) L	1,322 (52.05)	(41) to (25)	1,212 (47.72)
(15) R to (15) L	1,453 (57.20)	(41) to (12)	1,298 (51.10)
(22) R to (22) L	1,453 (57.20)	(41) to (21) R	944 (37.17)
(39) R to (39) L	1,392 (54.80)	(41) to (21) L	944 (37.17)
(40) R to (40) L	1,402 (55.20)	(41) to (17) R	1,332 (52.44)
(11) L to (17) R	1,168 (45.98)	(41) to (17) L	1,332 (52.44)
(11) R to (17) L	1,168 (45.98)		

DATUM DIMENSIONS

Body Structure

4. COMPARTMENT

S906337A1404

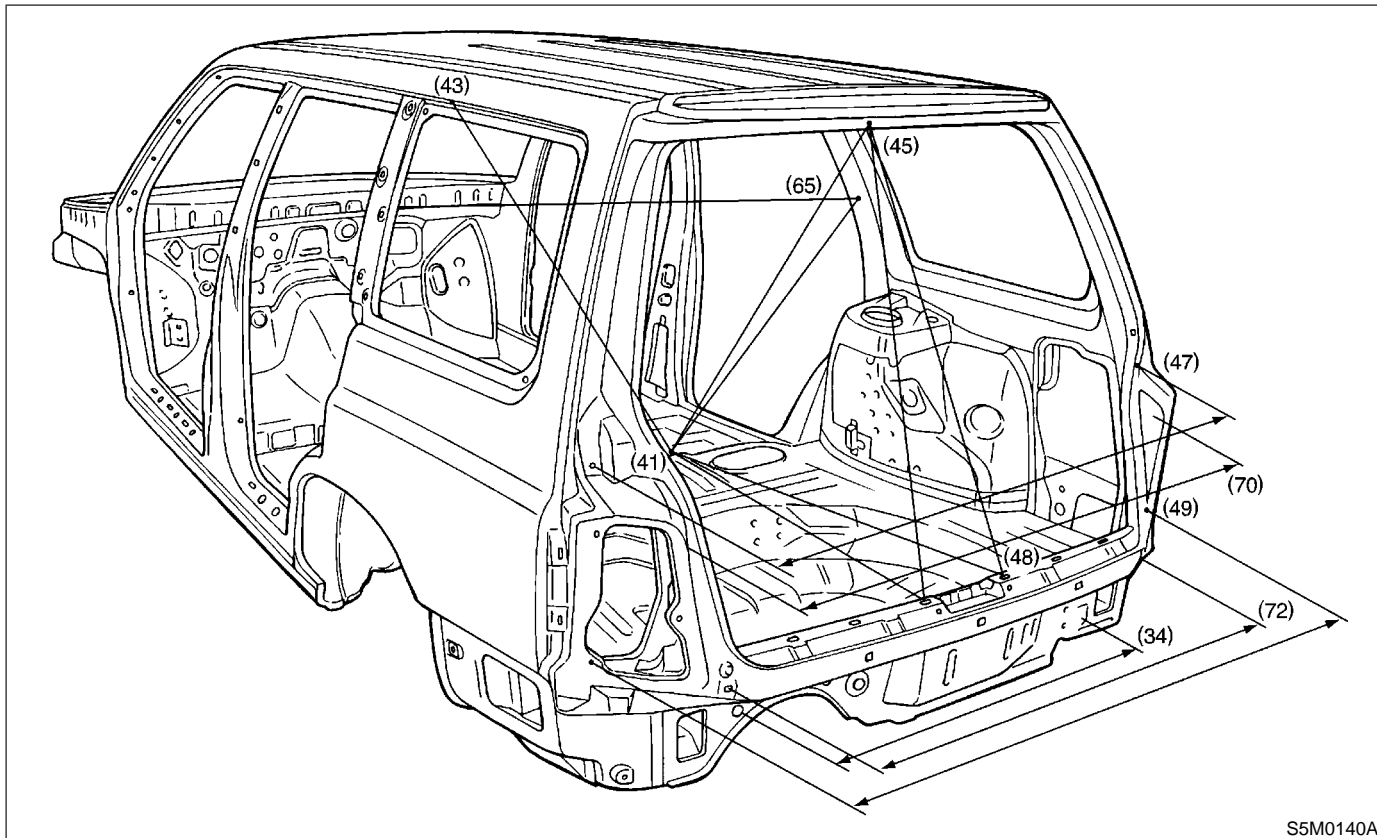

S5M0140A

		Unit: mm (in)	
Point to point	Dimension	Point to point	Dimension
(45) to (48) L	862 (33.94)	(41) to (65) R	1,131 (44.53)
(45) to (48) R	862 (33.94)	(41) to (65)L	1,131 (44.53)
(45) to (47) L	876 (34.49)	(41) to (45)	1,569 (61.77)
(45) to (47) R	876 (34.49)	(41) to (43) R	1,435 (56.50)
(47) R to (47) L	1,426 (56.14)	(41) to (43) L	1,435 (56.50)
(49)R to (49) L	1,479 (58.23)	(41) to (48) L	1,576 (62.05)
(34) R to (34) L	945 (37.20)	(41) to (48) R	1,576 (62.05)
(48) R to (46) R	992 (39.06)	(65) R to (65) L	1,267 (49.88)
(48) L to (46) L	992 (39.06)	(17) R to (76)	627 (24.68)
(70) R to (70) L	1,218 (47.95)	(17) L to (76)	680 (26.77)
(61) R to (75) R	447 (17.60)	(72) R to (72) L	1,111 (43.74)
(61) L to (75) L	447 (17.60)	(74) R to (75) R	480 (18.90)
(17) R to (75) R	1,137 (44.76)	(74) L to (75) L	480 (18.90)
(17) L to (75) L	1,137 (44.76)	(17) R to (73)	518 (20.39)
(45) to (71)	913 (35.94)	(17) L to (73)	476 (18.74)

DATUM DIMENSIONS

Body Structure

MEMO: