

CHASSIS SECTION

This service manual has been prepared to provide SUBARU service personnel with the necessary information and data for the correct maintenance and repair of SUBARU vehicles.

This manual includes the procedures for maintenance, disassembling, reassembling, inspection and adjustment of components and diagnostics for guidance of experienced mechanics.

Please peruse and utilize this manual fully to ensure complete repair work for satisfying our customers by keeping their vehicle in optimum condition. When replacement of parts during repair work is needed, be sure to use SUBARU genuine parts.

FRONT SUSPENSION FS

REAR SUSPENSION RS

WHEEL AND TIRE SYSTEM WT

DIFFERENTIALS DI

TRANSFER CASE TC

DRIVE SHAFT SYSTEM DS

ABS ABS

BRAKE BR

PARKING BRAKE PB

**POWER ASSISTED SYSTEM
(POWER STEERING)** PS

ABS (DIAGNOSTICS) ABS

All information, illustration and specifications contained in this manual are based on the latest product information available at the time of publication approval.

DRIVE SHAFT SYSTEM

DS

	Page
1. General Description.....	2
2. Propeller Shaft.....	14
3. Front Axle	17
4. Rear Axle.....	23
5. Front Drive Shaft.....	32
6. Front Drive Shaft Boot	37
7. Rear Drive Shaft.....	38
8. Rear Drive Shaft Boot.....	44
9. General Diagnostic Table	46

GENERAL DESCRIPTION

Drive Shaft System

1. General Description S301001

A: SPECIFICATIONS S301001E49

1. PROPELLER SHAFT S301001E4901

		Non-Turbo model	Turbo model
Propeller shaft type		UJ type	DOJ type
Front propeller shaft Joint-to-joint length: mm (in)	L ₁	585 (23.03)	580 (22.83)
		644 (25.35)	639 (25.16)
Rear propeller shaft Joint-to-joint length: mm (in)		707 (27.83)	712 (28.03)
Outside dia. of tube mm (in)		D ₁	63.5 (2.500)
		D ₂	57.0 (2.244)

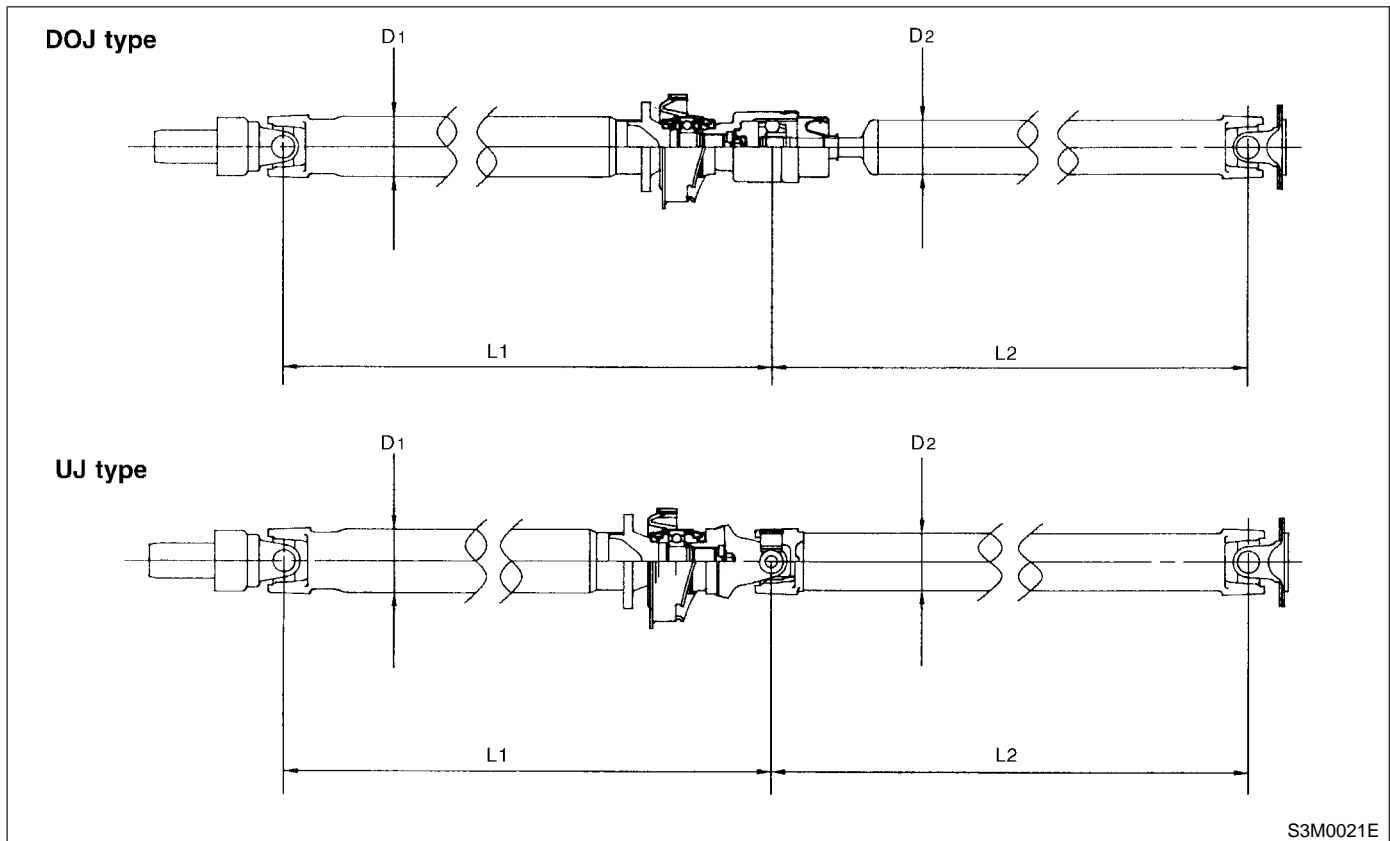

2. FRONT DRIVE SHAFT ASSEMBLY S301001E4902

Model	Tone wheel	Type of drive shaft assembly	SHAFT	Boot band identification color
			Shaft diameter	
Non-TURBO MT (With ABS)	○	BJ87L+SFJ82	28 mm (1.10 in)	Pink
Non-TURBO MT (Without ABS)	—	BJ87L+SFJ82	28 mm (1.10 in)	Purple
Non-TURBO AT (With ABS)	○	BJ87L+SFJ82	26 mm (1.02 in)	—
TURBO				
Non-TURBO AT (Without ABS)	—	BJ87L+SFJ82	26 mm (1.02 in)	Brown

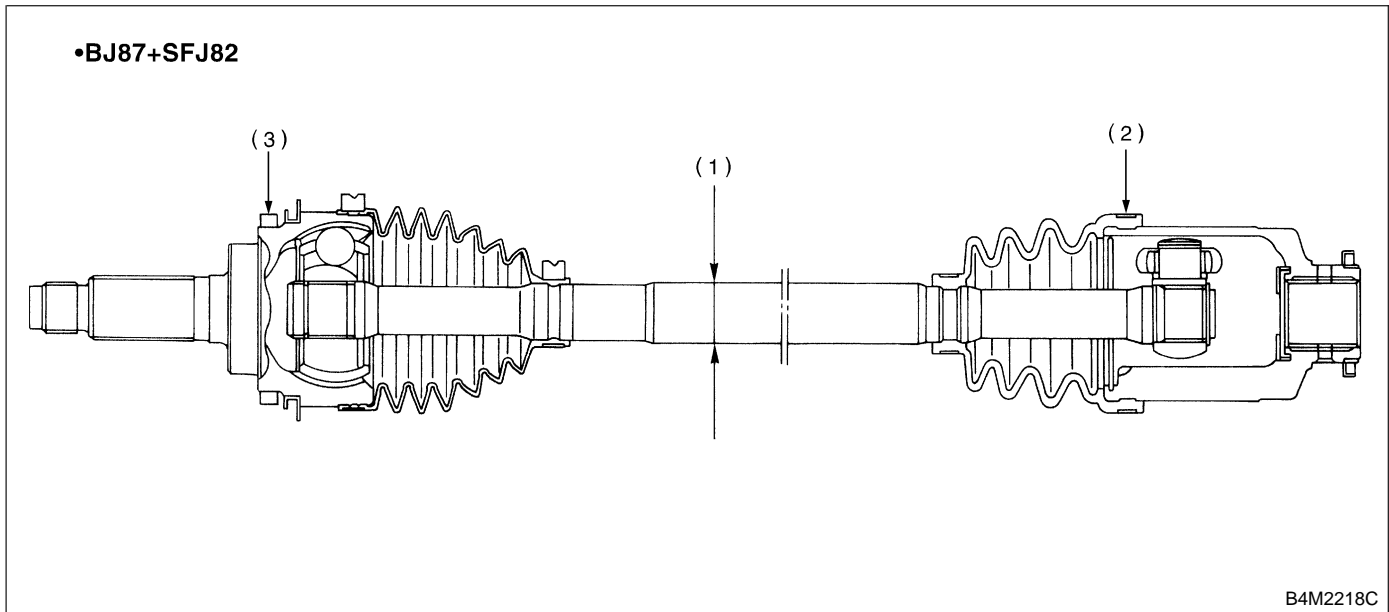

(1) Measuring point

(2) Boot band identification color

(3) Tone wheel

GENERAL DESCRIPTION

Drive Shaft System

3. REAR DRIVE SHAFT ASSEMBLY S301001E4903

Model	Type of axle shaft assembly	SHAFT	Boot band identification color
		No. of identification grooves on shaft	
TURBO	82AC-RH, 82AC-LH	2 (Two)	Auburn
NON-TURBO MT	79AC-RH, 79AC-LH	1 (One)	White
NON-TURBO AT	79AC	None	Orange

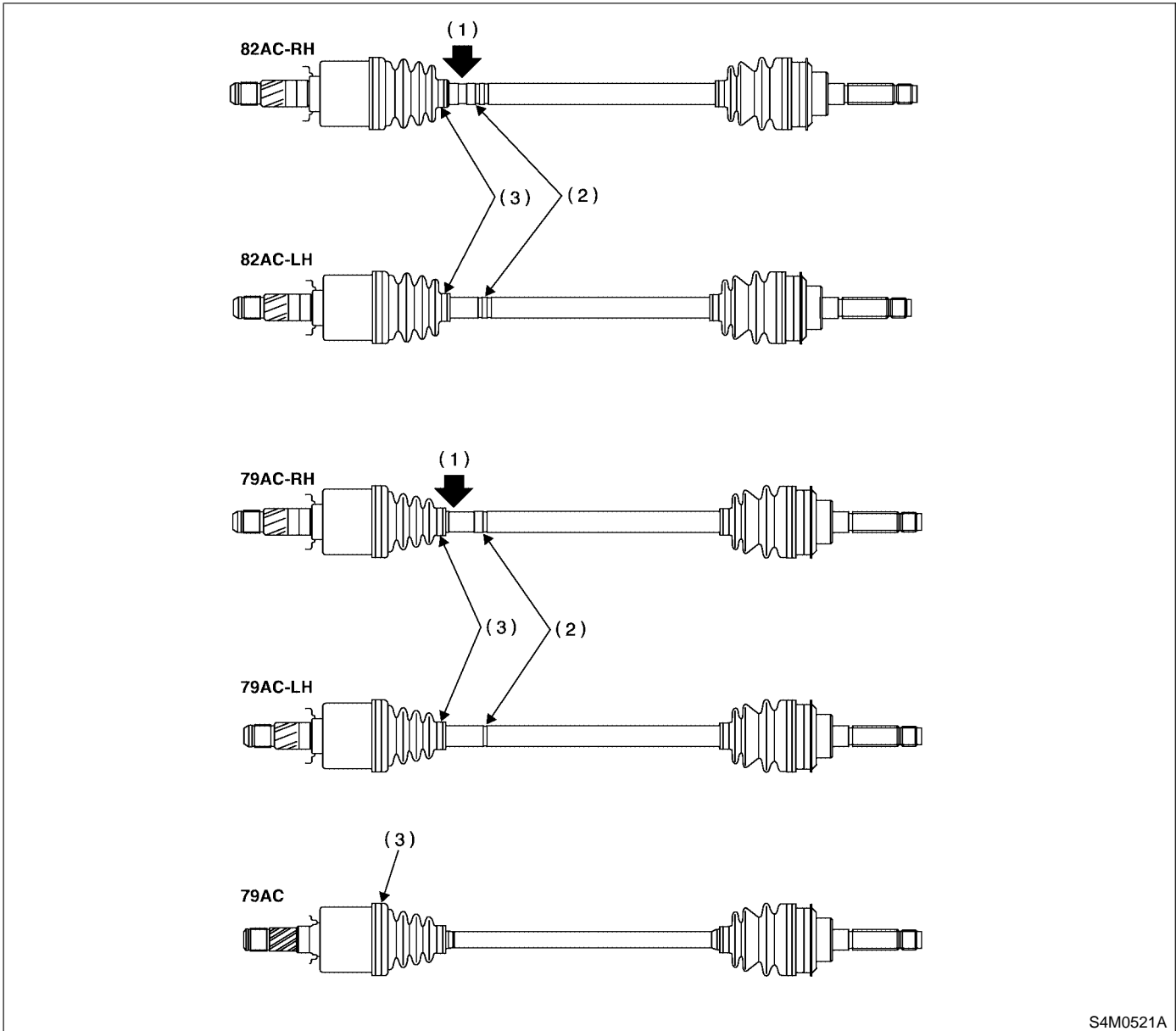

S4M0521A

(1) Indication mark of RH

(2) Identification padding

(3) Boot band Identification

B: COMPONENT S301001A05

1. PROPELLER SHAFT S301001A0501

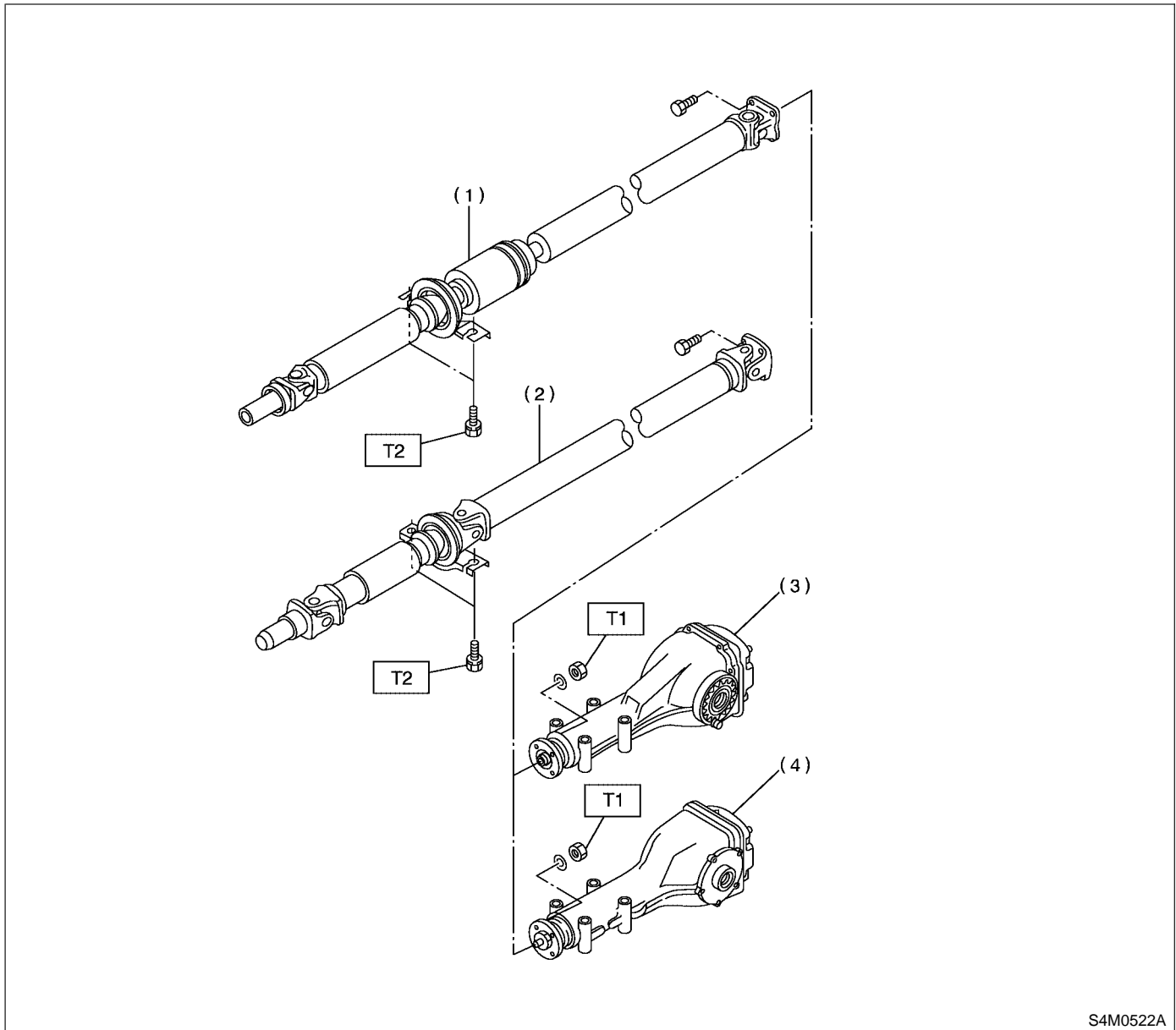

S4M0522A

- (1) Propeller shaft (Turbo model)
- (2) Propeller shaft (Non-Turbo model)
- (3) Rear differential (VA-type)
- (4) Rear differential (T-type)

Tightening torque: N·m (kgf·m, ft·lb)

T1: 31 (3.2, 23.1)

T2: 52 (5.3, 38.3)

GENERAL DESCRIPTION

Drive Shaft System

2. FRONT AXEL S301001A0502

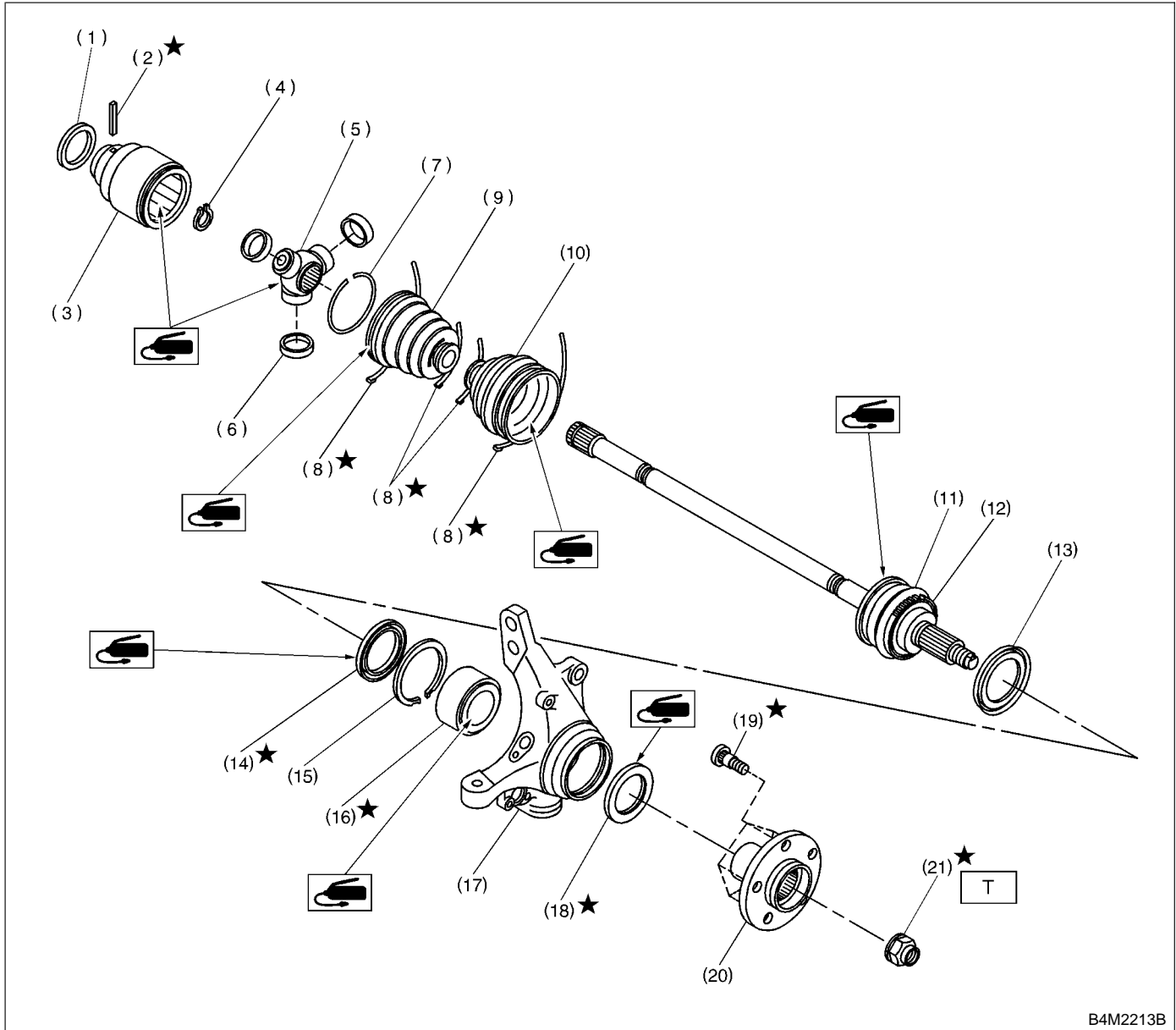

B4M2213B

- (1) Baffle plate (SFJ)
- (2) Spring pin
- (3) Outer race (SFJ)
- (4) Snap ring
- (5) Trunnion
- (6) Free ring
- (7) Circlip
- (8) Boot band
- (9) Boot (SFJ)

- (10) Boot (BJ)
- (11) BJ ASSY
- (12) Tone wheel
- (13) Baffle plate
- (14) Oil seal (IN)
- (15) Snap ring
- (16) Bearing
- (17) Housing
- (18) Oil seal (OUT)

- (19) Hub bolt
- (20) Hub
- (21) Axle nut

Tightening torque: N·m (kgf·m, ft·lb)
T: 186 (19, 137)

3. REAR AXLE S301001A0503

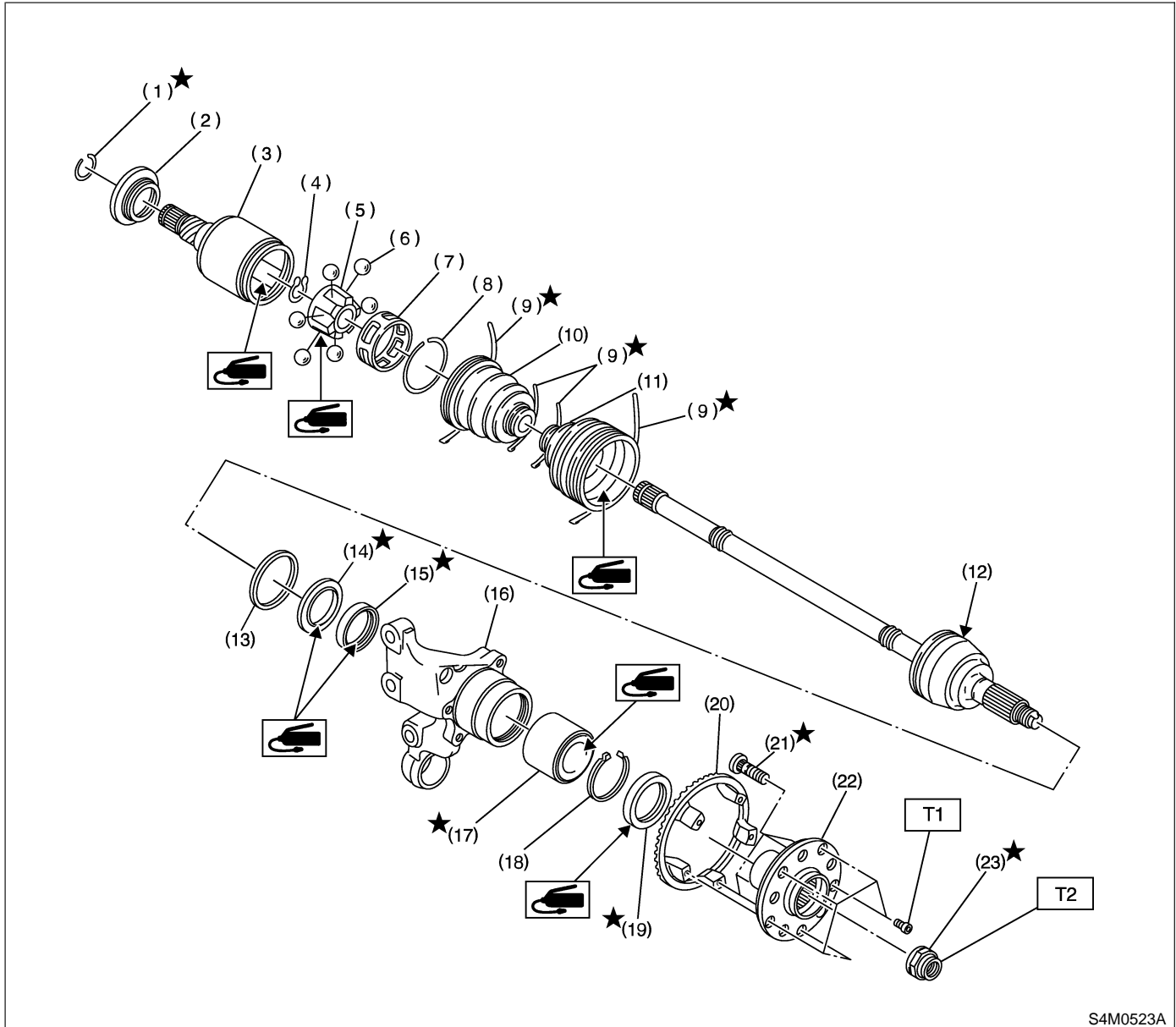

S4M0523A

- (1) Circlip (Non-turbo AT vehicle)
- (2) Baffle plate (DOJ)
- (3) Outer race (DOJ)
- (4) Snap ring
- (5) Inner race
- (6) Ball
- (7) Cage
- (8) Circlip
- (9) Boot band
- (10) Boot (DOJ)

- (11) Boot (BJ or EBJ)
- (12) BJ or EBJ ASSY
- (13) Oil seal (IN. No. 2)
- (14) Baffle plate
- (15) Oil seal (IN)
- (16) Housing
- (17) Bearing
- (18) Snap ring
- (19) Oil seal (OUT)
- (20) Tone wheel

- (21) Hub bolt
- (22) Hub
- (23) Axle nut

Tightening torque: N·m (kgf·m, ft·lb)

T1: 13 (1.3, 9.4)

T2: 186 (19, 137)

C: CAUTION S301001A03

- Wear working clothing, including a cap, protective goggles, and protective shoes during operation.
- Remove contamination including dirt and corrosion before removal, installation or disassembly.
- Keep the disassembled parts in order and protect them from dust or dirt.
- Before removal, installation or disassembly, be sure to clarify the failure. Avoid unnecessary removal, installation, disassembly, and replacement.
- Be careful not to burn your hands, because each part on the vehicle is hot after running.
- Use SUBARU genuine grease etc. or the equivalent. Do not mix grease etc. with that of another grade or from other manufacturers.
- Be sure to tighten fasteners including bolts and nuts to the specified torque.
- Place shop jacks or safety stands at the specified points.
- Apply grease onto sliding or revolution surfaces before installation.
- Before installing O-rings or snap rings, apply sufficient amount of grease to avoid damage and deformation.
- Before securing a part on a vise, place cushioning material such as wood blocks, aluminum plate, or shop cloth between the part and the vise.

D: PREPARATION TOOL S301001A17

1. SPECIAL TOOLS S301001A1701

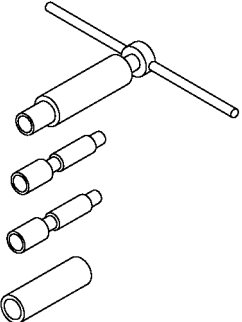
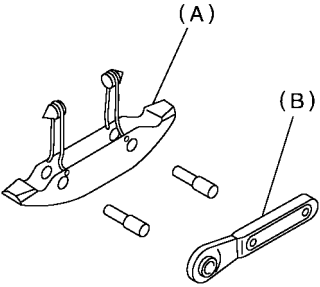
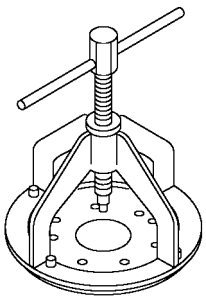
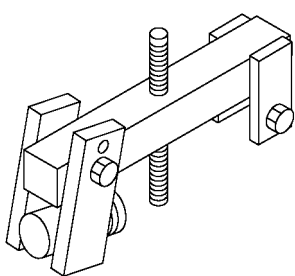
ILLUSTRATION	TOOL NUMBER	DESCRIPTION	REMARKS
 <p style="text-align: right; margin-right: 10px;">B4M2386</p>	922431000	AXLE SHAFT INSTALLER	<ul style="list-style-type: none"> ● Used for installing axle shaft into housing. ● Used with ADAPTER (927390000).
 <p style="text-align: right; margin-right: 10px;">B4M2387A</p>	925091000	BAND TIGHTENING TOOL	<ul style="list-style-type: none"> ● Used for tightening boot band. Except front axle housing side) (A) Jig for band (B) Ratchet wrench
 <p style="text-align: right; margin-right: 10px;">B4M2388</p>	926470000	AXLE SHAFT PULLER	Used for removing axle shaft.
 <p style="text-align: right; margin-right: 10px;">B4M2389</p>	927060000	HUB REMOVER	<ul style="list-style-type: none"> ● Used for removing front hub. ● Used with HUB STAND (927080000).

GENERAL DESCRIPTION

Drive Shaft System

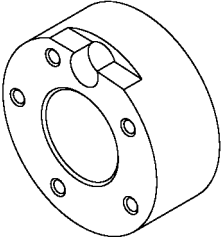
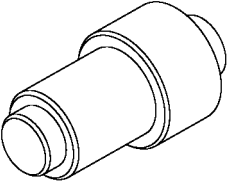
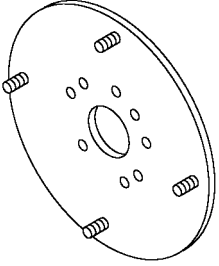
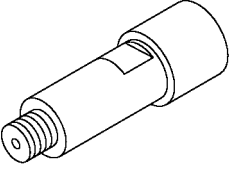
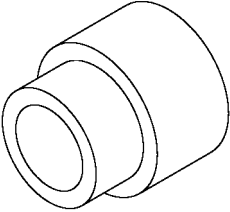
ILLUSTRATION	TOOL NUMBER	DESCRIPTION	REMARKS
 <p style="text-align: center;">B4M2390</p>	927080000	HUB STAND	Used for disassembling and assembling hub bolt in hub.
 <p style="text-align: center;">B4M2391</p>	927100000	BEARING REMOVER	<ul style="list-style-type: none"> ● Used for disassembling and assembling front housing bearing. ● Used with HOUSING STAND (927400000).
 <p style="text-align: center;">B4M2392</p>	927140000	PLATE	Same as plate 2 included in AXLE SHAFT PULLER (926470000).
 <p style="text-align: center;">B4M2393</p>	927390000	ADAPTER	Used as an adapter for AXLE SHAFT INSTALLER (922431000).
 <p style="text-align: center;">B4M2394</p>	927400000	HOUSING STAND	<ul style="list-style-type: none"> ● Used for disassembling and assembling front housing bearing. ● Used with BEARING PULLER (927100000).

GENERAL DESCRIPTION

Drive Shaft System

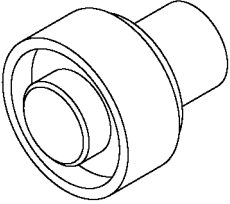
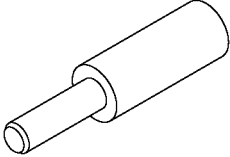
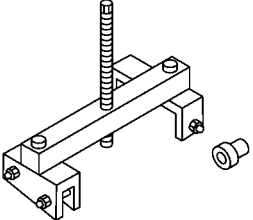
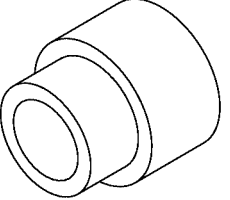
ILLUSTRATION	TOOL NUMBER	DESCRIPTION	REMARKS
 <p data-bbox="363 512 444 533">B4M2395</p>	927410000	OIL SEAL INSTALLER	<ul style="list-style-type: none"> ● Used for installing oil seal into front housing. ● Used with HOUSING STAND (927400000).
 <p data-bbox="363 873 444 894">B4M2399</p>	927120000	HUB INSTALLER	Used for installing hub.
 <p data-bbox="363 1262 444 1283">H5M0981</p>	927420000	HUB REMOVER	<ul style="list-style-type: none"> ● Used for removing rear hub. ● Used with HUB STAND (927080000).
 <p data-bbox="363 1646 444 1667">H5M0982</p>	927430000	HOUSING STAND	<ul style="list-style-type: none"> ● Used for disassembling and assembling rear housing bearing. ● Used with BEARING PULLER (927440000).

GENERAL DESCRIPTION

Drive Shaft System

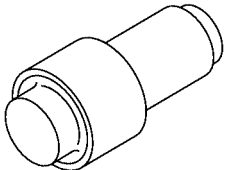
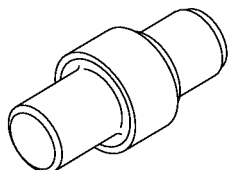
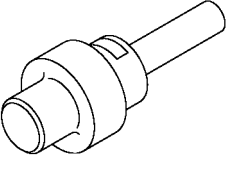
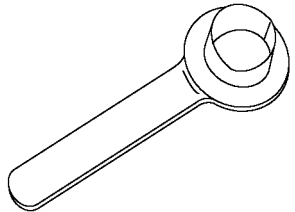
ILLUSTRATION	TOOL NUMBER	DESCRIPTION	REMARKS
 <p style="text-align: center;">H5M0983</p>	927440000	BEARING REMOVER	<ul style="list-style-type: none"> ● Used for disassembling and assembling rear housing bearing. ● Used with HOUSING STAND (927430000).
 <p style="text-align: center;">H5M0984</p>	927460000	OIL SEAL INSTALLER	<ul style="list-style-type: none"> ● Used for installing outer bearing and sub bearing into housing. ● Used with HOUSING STAND (927430000).
 <p style="text-align: center;">B4M2400</p>	927450000	HUB INSTALLER	<ul style="list-style-type: none"> ● Used for installing rear hub into hub ASSY. ● Used with HUB STAND (927080000).
 <p style="text-align: center;">B4M2401</p>	28099PA090	OIL SEAL PROTECTOR	<ul style="list-style-type: none"> ● Used for installing rear drive shaft into rear differential. ● For protecting oil seal.

GENERAL DESCRIPTION

Drive Shaft System

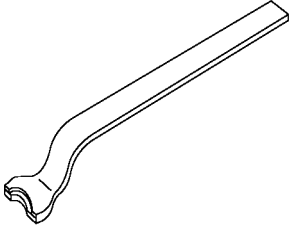
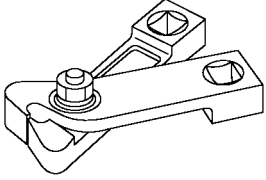
ILLUSTRATION	TOOL NUMBER	DESCRIPTION	REMARKS
 B4M2402	28099PA100	DRIVE SHAFT REMOVER	Used for removing rear drive shaft from rear differential.
 B4M2403	28099AC000	BOOT BAND PLI- ERS	Used for tightening front BJ boot band. (Front axle housing side)

2. GENERAL PURPOSE TOOLS S301001A1702

TOOL NAME	REMARKS
Puller	Used for removing ball joint from knuckle arm.
Dial Gauge	Used for inspecting propeller shaft run-out.
Snap Ring Pliers	Used for installing and removing snap ring.

PROPELLER SHAFT

2. Propeller Shaft S301160

A: REMOVAL S301160A18

NOTE:

- Before removing propeller shaft, wrap metal parts with a cloth or rubber material.
- In case of DOJ type, before removing propeller shaft, wrap metal parts (installed at the rubber boot of center DOJ) with a cloth or rubber material, as shown in the figure. Rubber boot may be damaged due to interference with adjacent metal parts while bending the DOJ during removal.

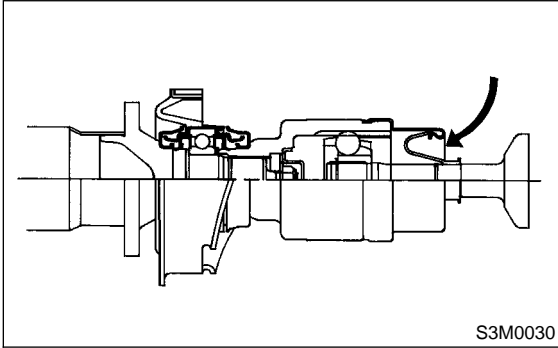

- 1) Set vehicle on a lift.
- 2) Disconnect ground terminal from battery.
- 3) Move select lever or gear shift lever to "N".
- 4) Release the parking brake.
- 5) Jack-up vehicle and support it with sturdy racks.
- 6) Remove front exhaust cover. (Non-Turbo model)

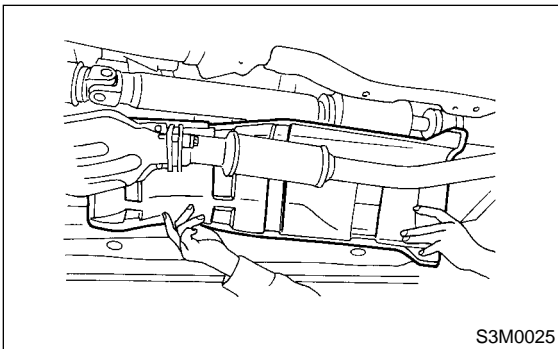

- 7) Remove differential mount front cover.

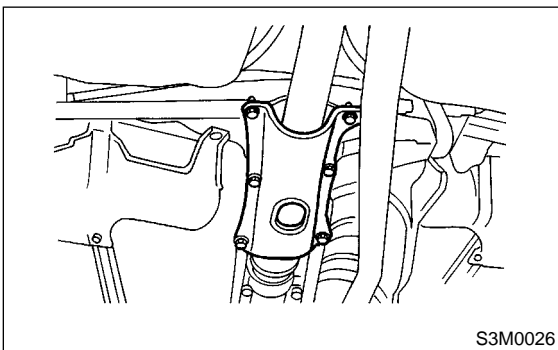

- 8) Remove the four bolts which hold propeller shaft to rear differential.

NOTE:

- Put matching mark on affected parts before removal.
- Remove all but one bolt.

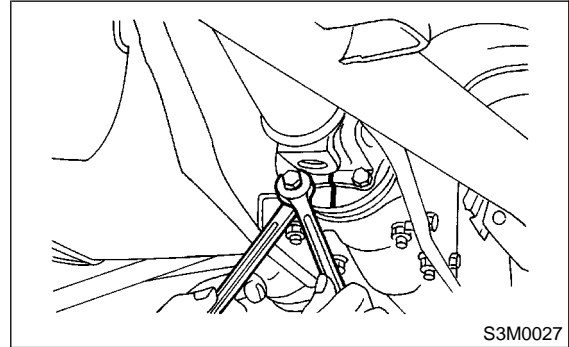

- 9) Remove the two bolts which hold center bearing to car body.

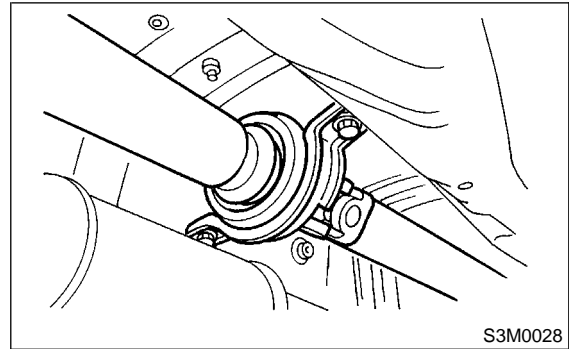

10) Remove propeller shaft from transmission.

CAUTION:

- Be sure not to damage oil seals and the frictional surface of sleeve yoke.
- Cover the center exhaust pipe with a cloth to keep off any ATF or oil spilled from transmission when removing propeller shaft.

NOTE:

- Be sure to use an empty oil can to catch oil flowing out when removing propeller shaft.
- Be sure to plug the opening in transmission after removal of propeller shaft.

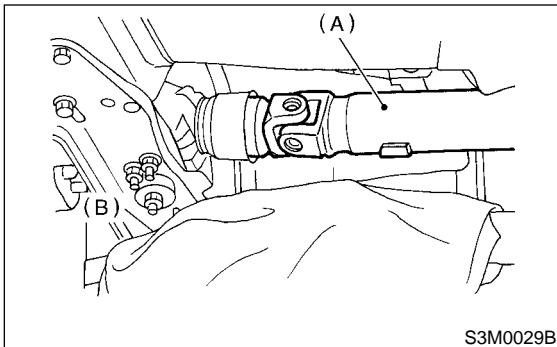

- (A) Propeller shaft
- (B) Cloth

11) Install the extension cap to transmission.

NOTE:

If extension cap is not available, place vinyl bag over opening and fasten with string to prevent gear oil or ATF from leaking.

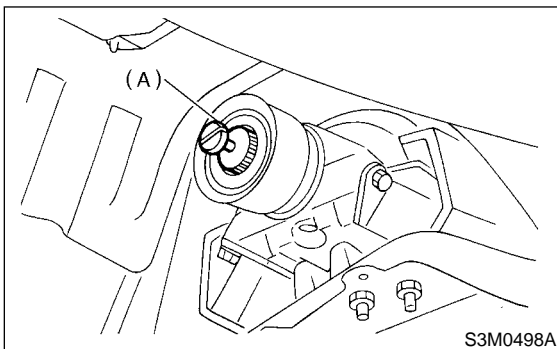

- (A) Extension cap

B: INSTALLATION S301160A11

1) Insert sleeve yoke into transmission and attach center bearing to body.

Tightening torque:

52 N·m (5.3 kgf-m, 38.3 ft-lb)

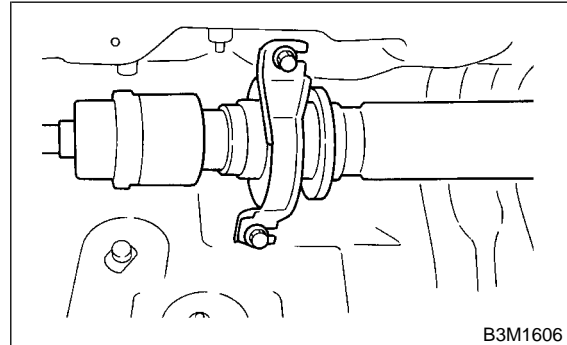

2) Align matching marks and connect flange yoke and rear differential.

Tightening torque:

31 N·m (3.2 kgf-m, 23.1 ft-lb)

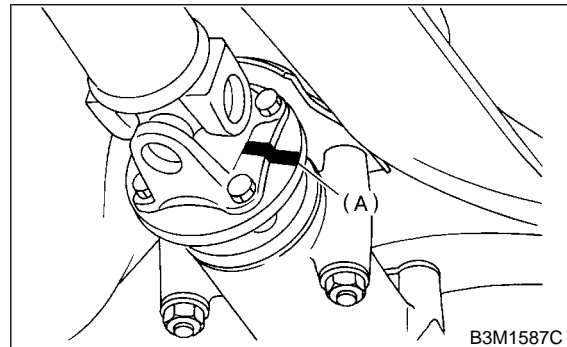

- (A) Matching mark

- 3) Install front exhaust cover. (Non-turbo model)
- 4) Install differential mount front cover.

Tightening torque:

88 N·m (9.0 kgf-m, 65 ft-lb)

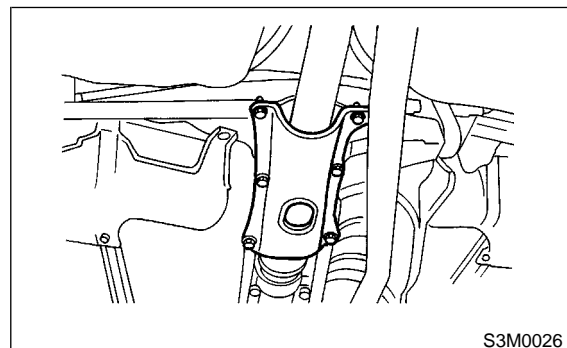

PROPELLER SHAFT

Drive Shaft System

C: INSPECTION S301160A10

NOTE:

Do not disassemble propeller shaft. Check the following and replace if necessary.

- 1) Tube surfaces for dents or cracks
- 2) Splines for deformation or abnormal wear
- 3) Joints for non-smooth operation or abnormal noise
- 4) Center bearing for free play, noise or non-smooth operation
- 5) Oil seals for abnormal wear or damage
- 6) Center bearing for breakage

Check the following points with propeller shaft installed in vehicle.

1. JOINTS AND CONNECTIONS S301160A1001

- 1) Remove center exhaust pipes.
- 2) Remove heat shield cover.
- 3) Check for any looseness of yoke flange connecting bolts and center bearing retaining bolts.

2. SPLINES AND BEARING LOCATIONS S301160A1002

- 1) Remove front exhaust cover. (Non-turbo model)
- 2) Turn propeller shaft by hand to see if abnormal free play exists at splines. Also move yokes to see if abnormal free play exists at spiders and bearings.

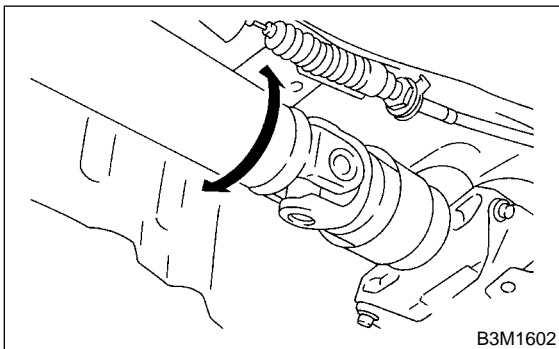

3. RUNOUT OF PROPELLER SHAFT S301160A1003

- 1) Remove front exhaust cover. (Non-turbo model)
- 2) Turn rear wheels by hand to check for "runout" of propeller shaft.

NOTE:

Measure runout with a dial gauge at the center of front and rear propeller shaft tubes.

Runout:

Limit 0.6 mm (0.024 in)

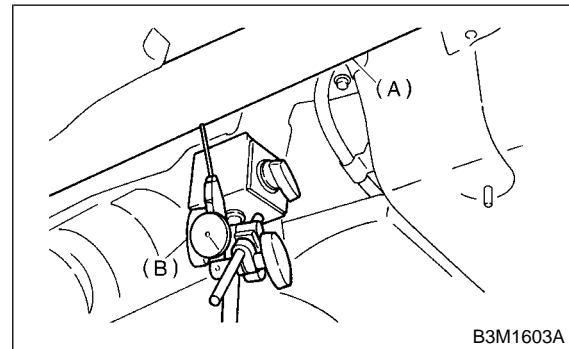

- (A) Propeller shaft
(B) Dial gauge

4. CENTER BEARING FREE PLAY S301160A1004

- 1) Remove front exhaust cover. (Non-turbo model)
- 2) While holding propeller shaft near center bearing with your hand, move it up and down, and left and right to check for any abnormal bearing free play.

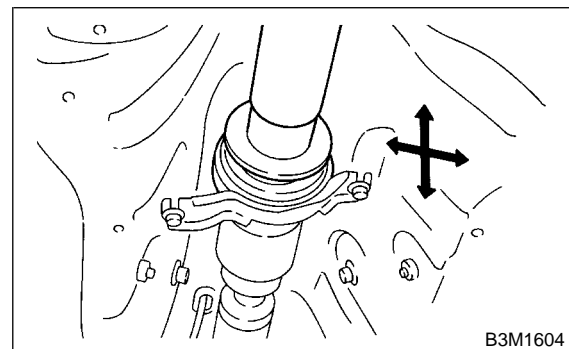

3. Front Axle S301148

A: REMOVAL S301148A18

- 1) Disconnect ground terminal from battery.
- 2) Jack-up vehicle, support it with safety stands, and remove front wheels.
- 3) Unlock axle nut.

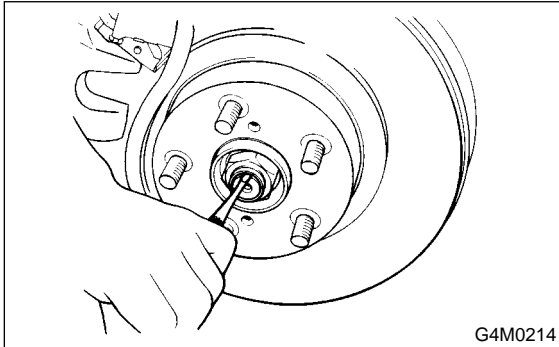

- 4) Remove axle nut using a socket wrench.

CAUTION:

Be sure to loose and retighten axle nut after removing wheel from vehicle. Failure to follow this rule may damage wheel bearings.

- 5) Remove stabilizer link.

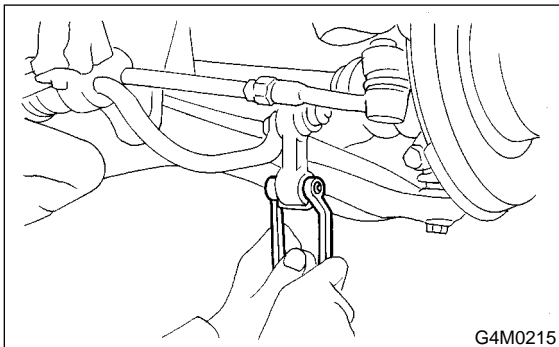

- 6) Remove disc brake caliper from housing, and suspend it from strut using a wire.
- 7) Remove disc rotor from hub.
If disc rotor seizes up within hub, drive disc rotor out by installing an 8-mm bolt in screw hole on the rotor.

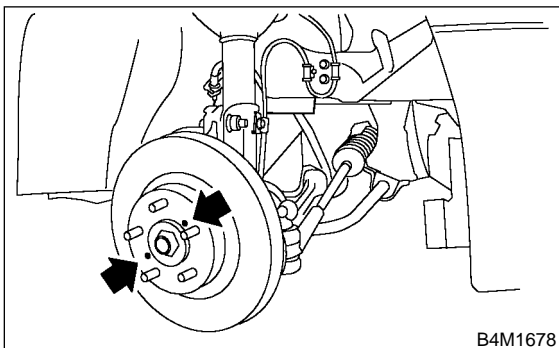

- 8) Remove cotter pin and castle nut which secure tie-rod end to housing knuckle arm.

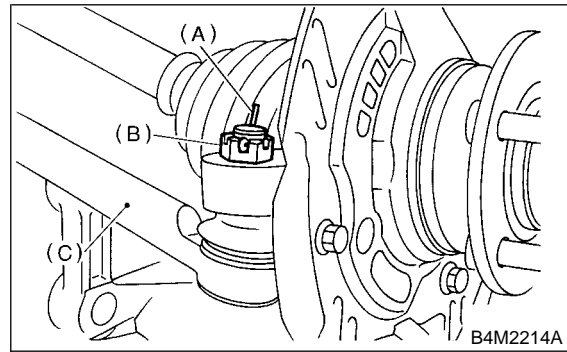

- (A) Cotter pin
- (B) Castle nut
- (C) Tie-rod

- 9) Using a puller, remove tie-rod ball joint from knuckle arm.

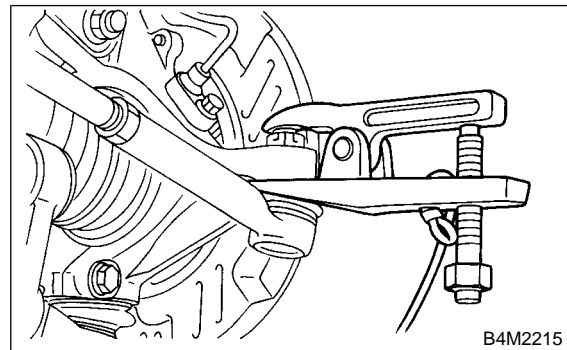

- 10) Remove ABS sensor assembly and harness in advance. (ABS equipped model)

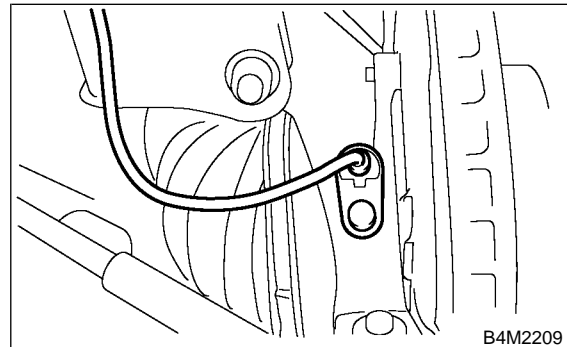

FRONT AXLE

Drive Shaft System

11) Remove bolt which secures sensor harness to strut. (ABS equipped model)

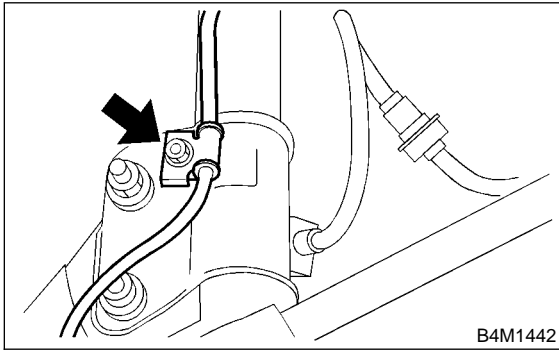

12) Remove transverse link ball joint from housing.

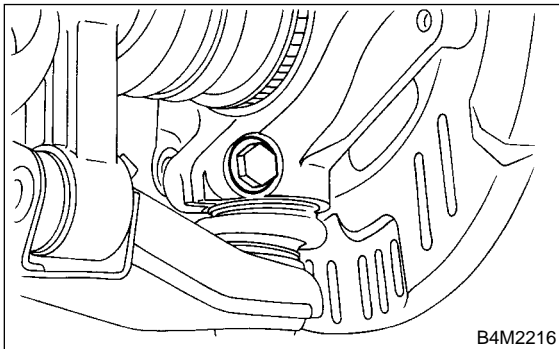

13) Remove SFJ from transmission spindle.
14) Remove front drive shaft assembly from hub.
If it is hard to remove, use STs.
ST1 926470000 AXLE SHAFT PULLER
ST2 927140000 PLATE

CAUTION:

- Be careful not to damage oil seal lip and tone wheel when removing front drive shaft.
- When replacing front drive shaft, also replace inner oil seal.

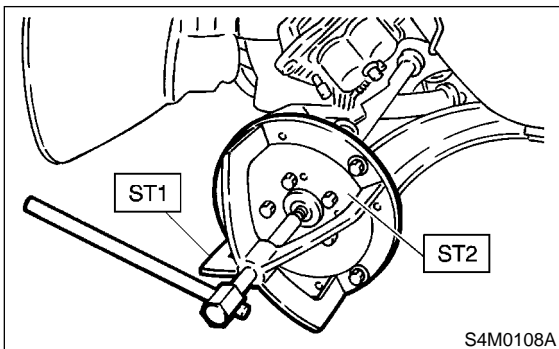

15) After scribing an alignment mark on camber adjusting bolt head, remove bolts which connect housing and strut, and disconnect housing from strut.

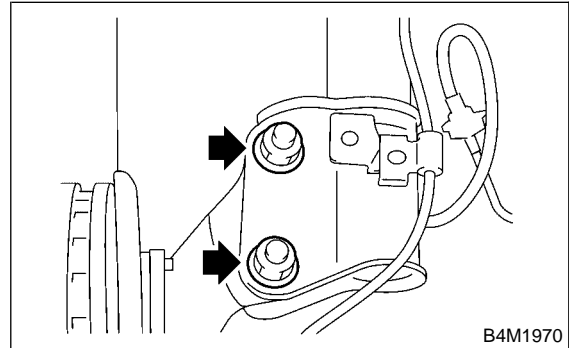

B: INSTALLATION S301148A11

1) Install transverse link ball joint to housing.

Tightening torque:

49 N·m (5.0 kgf-m, 36 ft-lb)

2) While aligning alignment mark on camber adjusting bolt head, connect housing and strut.

CAUTION:

Use a new self-locking nut.

Tightening torque:

155 N·m (15.8 kgf-m, 114 ft-lb)

3) Install ABS sensor on housing.

Tightening torque:

32 N·m (3.3 kgf-m, 23.9 ft-lb)

4) Install ABS sensor harness on strut.

5) Install disc rotor on hub.

6) Install disc brake caliper on housing.

Tightening torque:

78 N·m (8 kgf-m, 57.9 ft-lb)

7) Install front drive shaft. <Ref. to DS-32 INSTALLATION, Front Drive Shaft.>

8) Connect stabilizer link.

9) Connect tie-rod end ball joint and knuckle arm with a castle nut, and insert cotter pin into tie-rod end.

Castle nut tightening torque:

Tighten to 27.0 N-m (2.75 kgf-m, 19.9 ft-lb), and tighten further within 60° until cotter pin hole is aligned with a slot in the nut.

CAUTION:

When connecting, do not hit cap at the bottom of tie-rod end with hammer.

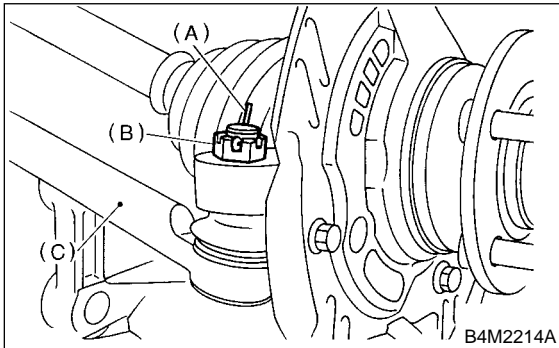

- (A) Cotter pin
- (B) Castle nut
- (C) Tie-rod

10) While depressing brake pedal, tighten axle nut and lock it securely.

Tightening torque:

186 N-m (19 kgf-m, 137 ft-lb)

CAUTION:

- Use a new axle nut.
- Always tighten axle nut before installing wheel on vehicle. If wheel is installed and comes in contact with ground when axle nut is loose, wheel bearings may be damaged.
- Be sure to tighten axle nut to specified torque. Do not overtighten it as this may damage wheel bearing.

11) After tightening axle nut, lock it securely.

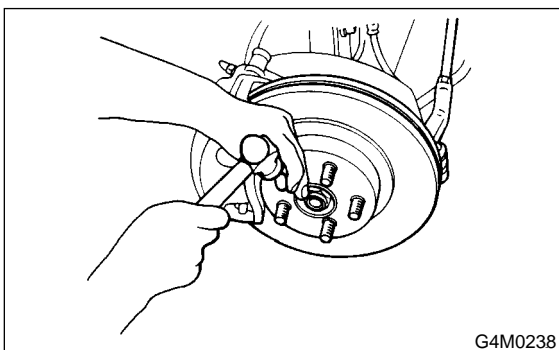

12) Install wheel and tighten wheel nuts to specified torque.

Tightening torque:

88 N-m (9 kgf-m, 65 ft-lb)

C: DISASSEMBLY

S301148A06

- 1) Using ST1, support housing and hub securely.
- 2) Attach ST2 to housing and drive hub out.

ST1 927060000 HUB REMOVER

ST2 927080000 HUB STAND

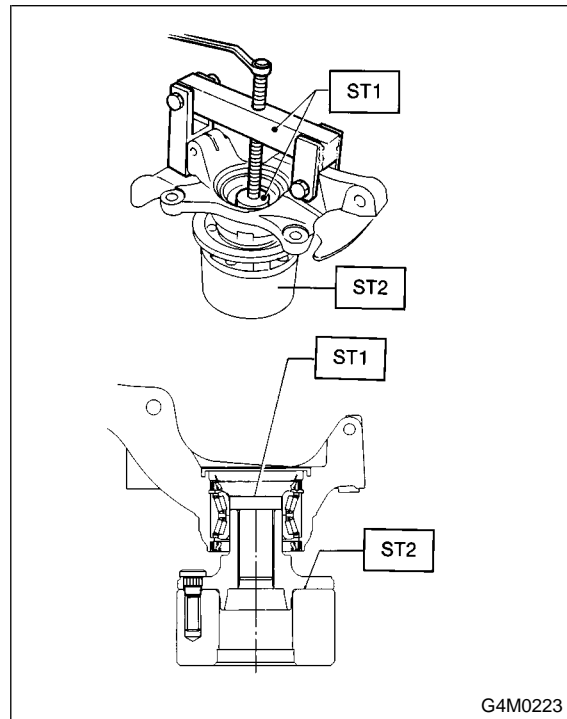

If inner bearing race remains in the hub, remove it with a suitable tool (commercially available).

CAUTION:

- Be careful not to scratch polished area of hub.
- Be sure to install inner race on the side of outer race from which it was removed.

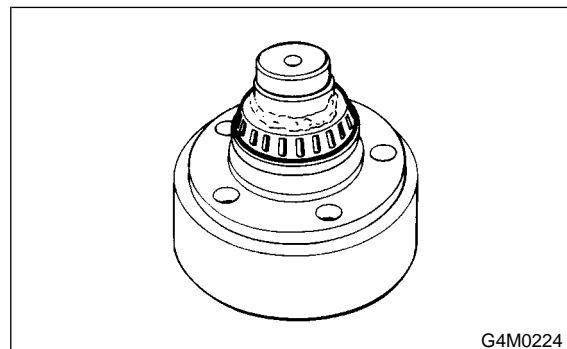

FRONT AXLE

Drive Shaft System

3) Remove disc cover from housing.

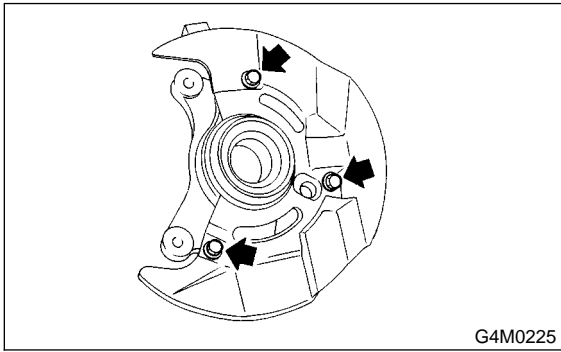

4) Using a standard screwdriver, remove outer and inner oil seals.

CAUTION:

Do not use old oil seals.

5) Using flat bladed screwdriver, remove snap ring.

CAUTION:

Remove without scratching axle housing.

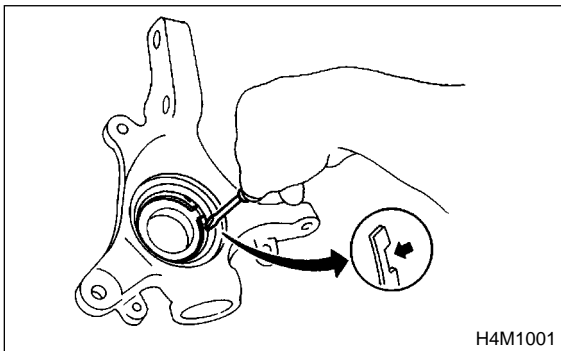

6) Using ST1, support housing securely.

7) Using ST2, press inner race to drive out outer bearing.

ST1 927400000 HOUSING STAND

ST2 927100000 BEARING REMOVER

CAUTION:

- Do not remove outer race unless it is faulty.
- Discard outer race after removal.
- Do not replace inner or outer race separately; always replace as a unit.

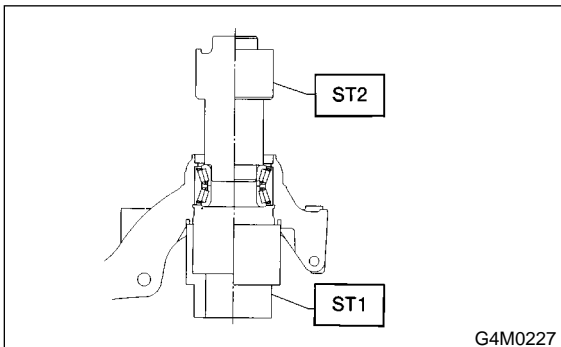

8) Using ST and a hydraulic press, drive hub bolts out.

ST 927080000 HUB STAND

CAUTION:

Be careful not to hammer hub bolts. This may deform hub.

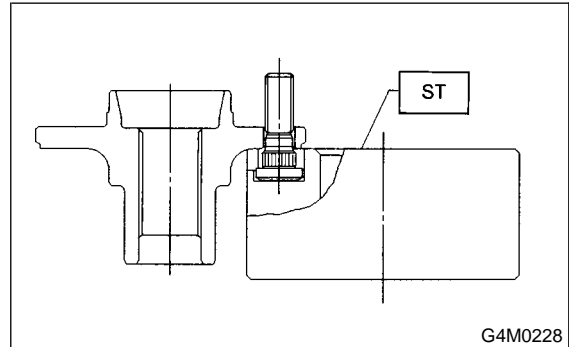

D: ASSEMBLY

S301148A02

1) Attach hub to ST securely.

ST 927080000 HUB STAND

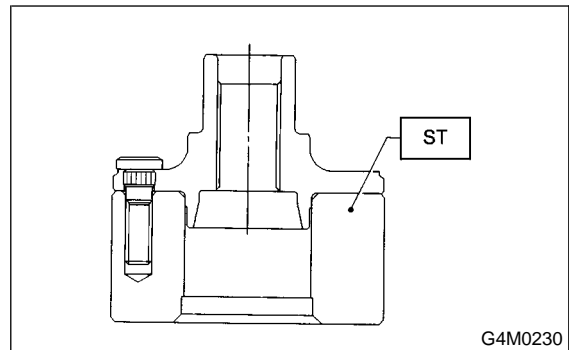

2) Using a hydraulic press, press new hub bolts into place.

CAUTION:

Be sure to press hub bolts until their seating surfaces contact the hub.

NOTE:

Use 12 mm (0.47 in) dia. holes in HUB STAND to prevent bolts from tilting.

3) Clean dust or foreign particles from inside the housing.

4) Using ST1 and ST2, press a new bearing into place.

ST1 927400000 HOUSING STAND

ST2 927100000 BEARING REMOVER

CAUTION:

- Always press outer race when installing bearing.
- Be careful not to remove plastic lock from inner race when installing bearing.
- Charge bearing with new grease when outer race is not removed.

Specified grease:

SHELL 6459N

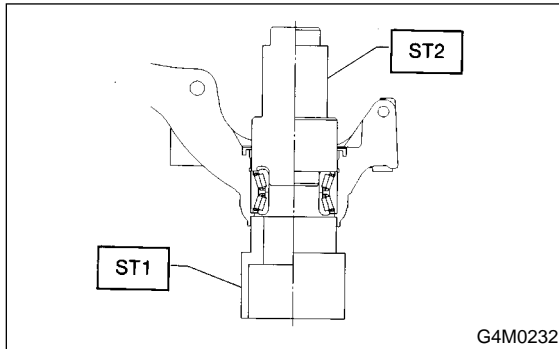

5) Using pliers, install snap ring in its groove.

CAUTION:

- Make sure to install it firmly to groove.
- Install without scratching axle housing.

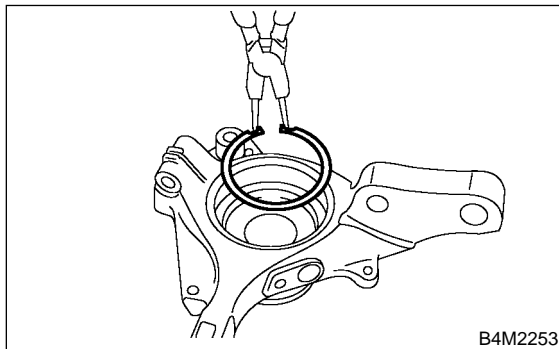

6) Using ST1 and ST2, press inner oil seal until it contacts circlip.

- ST1 927410000 OIL SEAL INSTALLER
ST2 927400000 HOUSING STAND

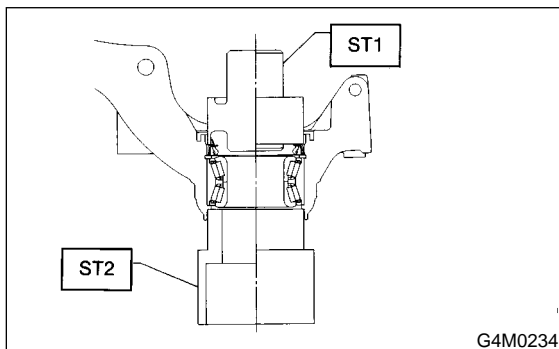

7) Invert ST and housing.

- ST 927400000 HOUSING STAND

8) Using ST1 and ST2, press outer oil seal until it contacts the bottom of housing.

- ST1 927410000 OIL SEAL INSTALLER
ST2 927400000 HOUSING STAND

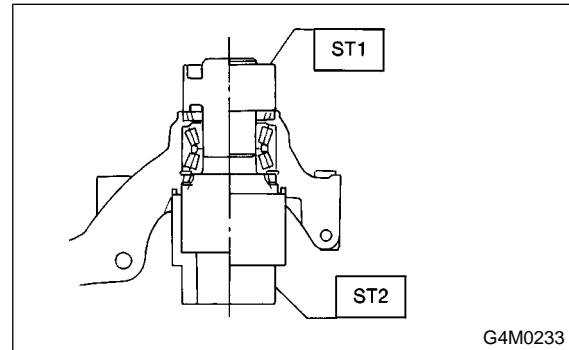

9) Apply sufficient grease to oil seal lip.

Specified grease

SHELL 6459N

CAUTION:

- If specified grease is not available, remove bearing grease and apply Auto Rex A instead.
- Do not mix different types of grease.

10) Install disc cover to housing the three bolts.

Tightening torque:

18 N·m (1.8 kgf·m, 13.0 ft·lb)

11) Attach hub to ST1 securely.

12) Clean dust or foreign particles from the polished surface of hub.

13) Using ST2, press bearing into hub by driving inner race.

- ST1 927080000 HUB STAND
ST2 927120000 HUB INSTALLER

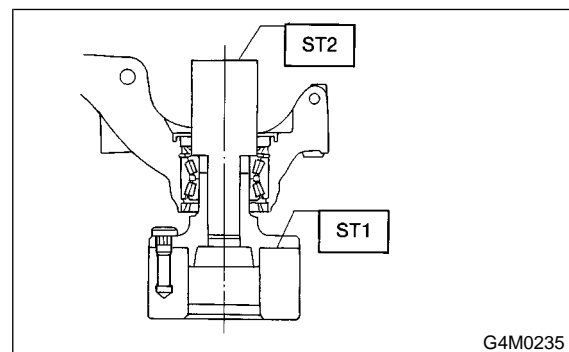

E: INSPECTION S301148A10

1) Moving front tire up and down by hand, check that there is no backlash in the bearing. And check that wheel rotates smoothly.

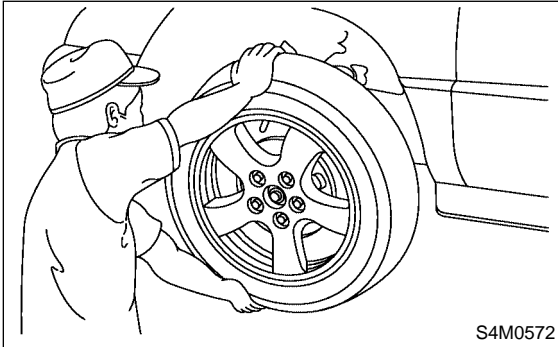

2) Inspect the removed parts for wear and damage. If defective, replace with new ones.

CAUTION:

- If bearing is faulty, replace it as the bearing set.
- Be sure to replace oil seal at every overhaul.

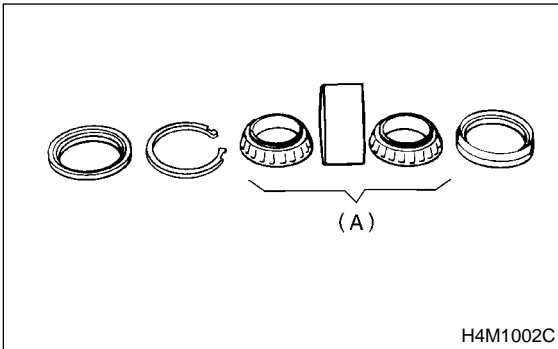

(A) Replace as a set.

4. Rear Axle S301154

A: REMOVAL S301154A18

1. DISC BRAKE S301154A1802

- 1) Disconnect ground cable from battery.
- 2) Jack-up vehicle, and remove rear wheel cap and wheels.

CAUTION:

Be sure to loosen and retighten axle nut after removing wheel from vehicle. Failure to follow this rule may damage wheel bearings.

- 3) Unlock axle nut.
- 4) Remove axle nut using a socket wrench.
- 5) Return parking brake lever and loosen adjusting nut.

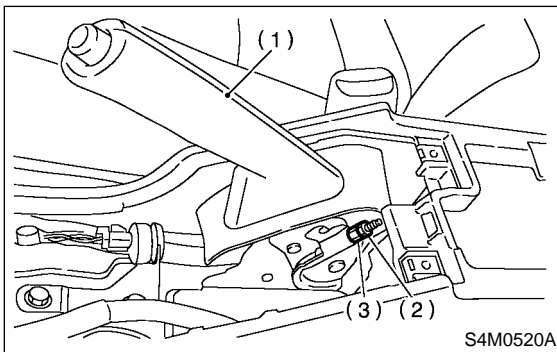

- (1) Parking brake lever
- (2) Lock nut
- (3) Adjusting nut

- 6) Remove disc brake caliper from back plate, and suspend it from strut using a piece of wire.

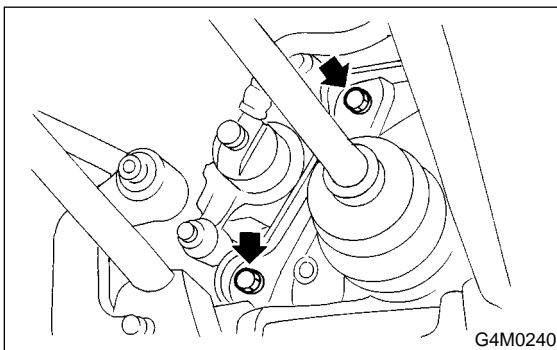

- 7) Remove disc rotor from hub.

NOTE:

If disc rotor seizes up within hub, drive it out by installing an 8-mm bolt into bolt hole in disc rotor.

- 8) Disconnect parking brake cable end.

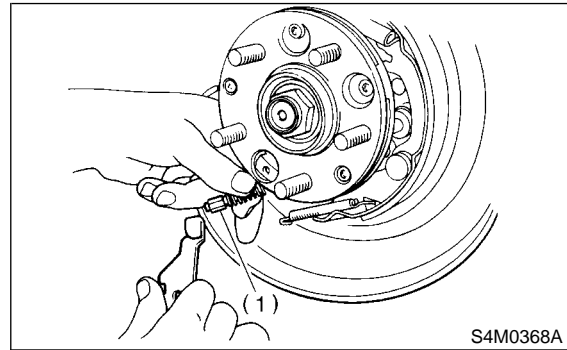

- (1) Cable end

- 9) Disconnect rear stabilizer from rear lateral link.
- 10) Remove bolts which secure trailing link assembly to rear housing.

CAUTION:

Discard old self-locking nut. Replace with a new one.

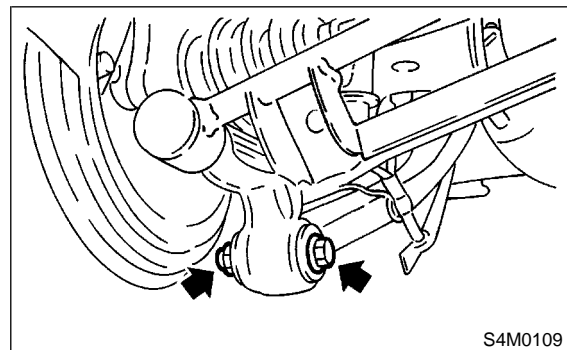

- 11) Remove bolts which secure lateral link assembly to rear housing.

CAUTION:

Discard old self-locking nut. Replace with a new one.

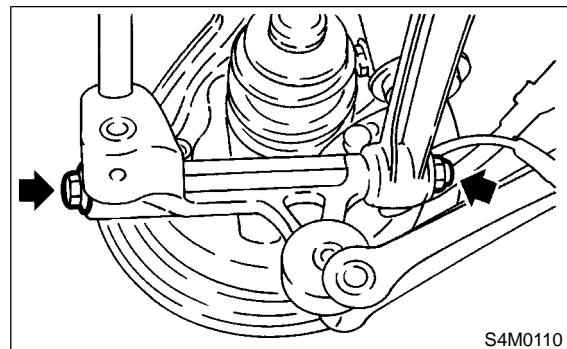

REAR AXLE

Drive Shaft System

12) Disengage BJ from housing splines, and remove rear drive shaft assembly. If it is hard to remove, use STs.

ST1 926470000 AXLE SHAFT PULLER

ST2 927140000 PLATE

CAUTION:

- Be careful not to damage oil seal lip when removing rear drive shaft.
- When rear drive shaft is to be replaced, also replace inner oil seal with a new one.

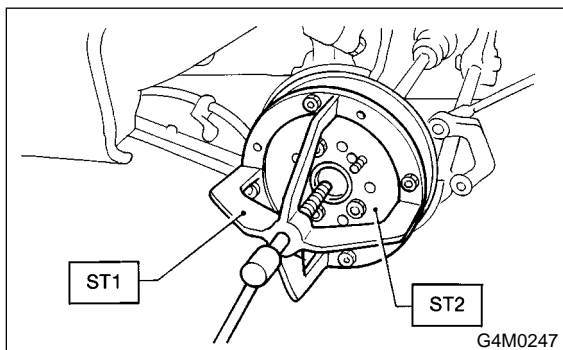

13) Remove rear ABS sensor from back plate (only vehicle equipped with ABS).

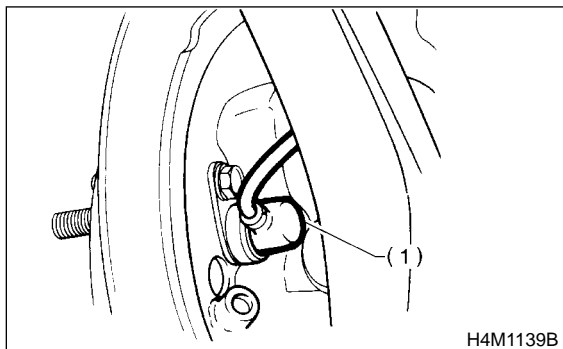

(1) ABS sensor

14) Remove bolts which secure rear housing to strut, and separate the two.

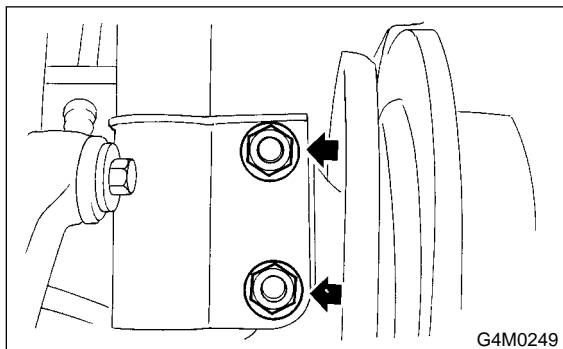

2. DRUM BRAKE S301154A1803

- 1) Disconnect ground cable from battery.
- 2) Jack-up vehicle, and remove rear wheel cap and wheels.

CAUTION:

Be sure to loosen and retighten axle nut after removing wheel from vehicle. Failure to follow this rule may damage wheel bearings.

- 3) Unlock axle nut.
- 4) Remove axle nut using a socket wrench.
- 5) Return parking brake lever and loosen adjusting nut.

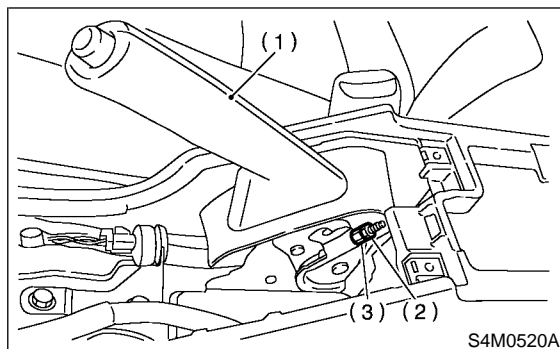

- (1) Parking brake lever
- (2) Lock nut
- (3) Adjusting nut

- 6) Remove brake drum from hub.
- 7) If it is difficult to remove brake drum, remove adjusting hole cover from back plate, and then turn adjusting screw using a slot-type screwdriver until brake shoe separates from the drum.

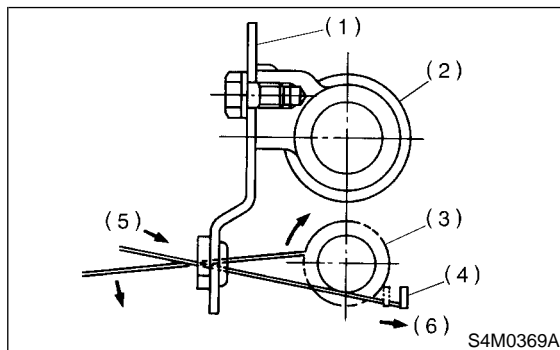

- (1) Back plate
- (2) Wheel cylinder
- (3) Adjuster ASSY pawls
- (4) Adjusting lever
- (5) Tightening direction
- (6) Push

NOTE:

If brake drum is difficult to remove, drive it out by installing an 8-mm bolt into bolt hole in brake drum.

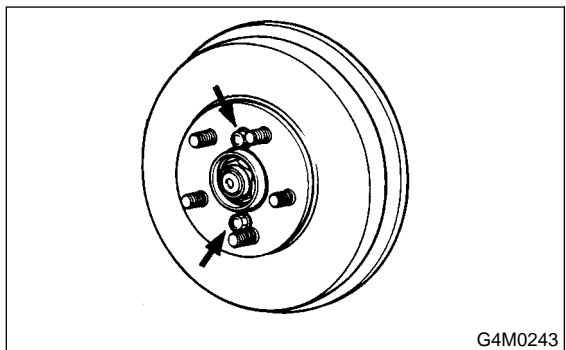

G4M0243

8) Using a flare-nut wrench, disconnect brake pipe from wheel cylinder.

CAUTION:

Cover open end of wheel cylinder to prevent entry of foreign particles.

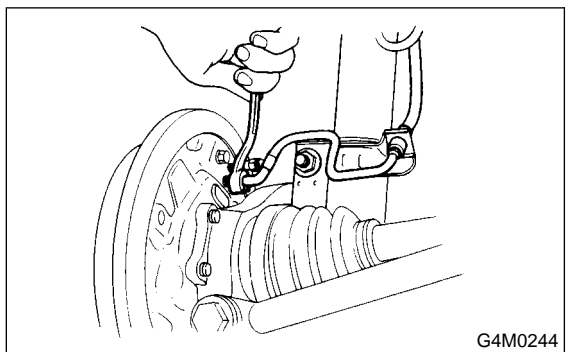

G4M0244

9) Disconnect parking brake cable end.

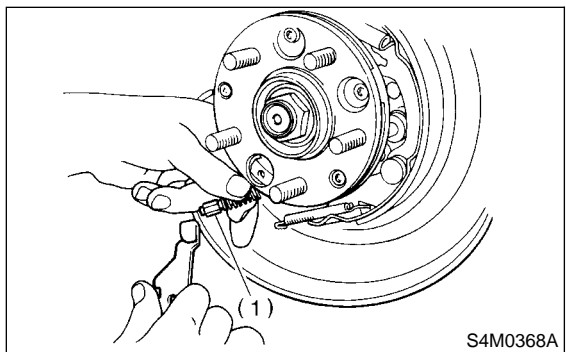

S4M0368A

(1) Cable end

10) Disconnect rear stabilizer from rear lateral link.

11) Remove bolts which secure trailing link assembly to rear housing.

CAUTION:

Discard old self-locking nut. Replace with a new one.

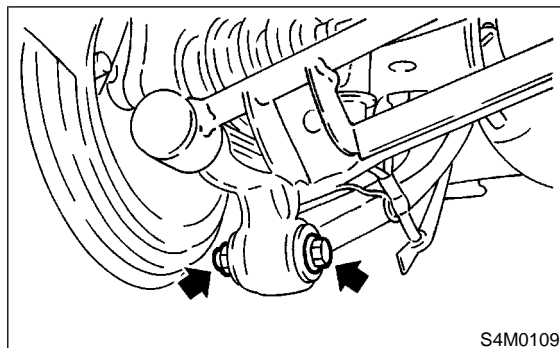

S4M0109

12) Remove bolts which secure lateral link assembly to rear housing.

CAUTION:

Discard old self-locking nut. Replace with a new one.

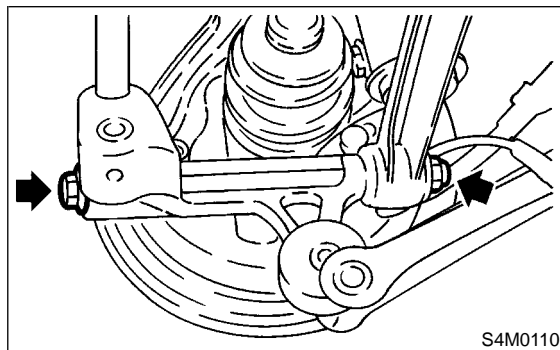

S4M0110

13) Disengage BJ from housing splines, and remove rear drive shaft assembly. If it is hard to remove, use STs.

- ST1 926470000 AXLE SHAFT PULLER
- ST2 927140000 PLATE

CAUTION:

- Be careful not to damage oil seal lip when removing rear drive shaft.
- When rear drive shaft is to be replaced, also replace inner oil seal with a new one.

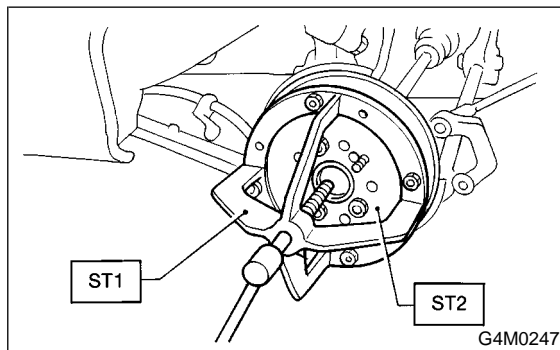

G4M0247

REAR AXLE

Drive Shaft System

- 14) Remove rear ABS sensor from back plate (only vehicle equipped with ABS).

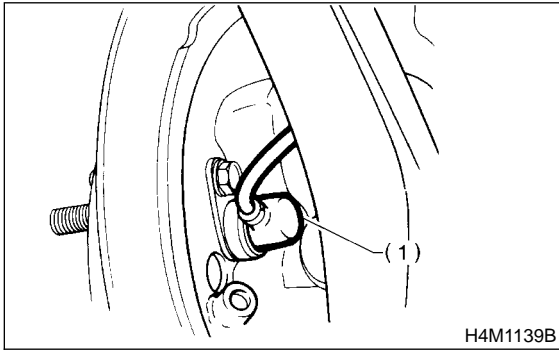

(1) ABS sensor

- 15) Remove bolts which secure rear housing to strut, and separate the two.

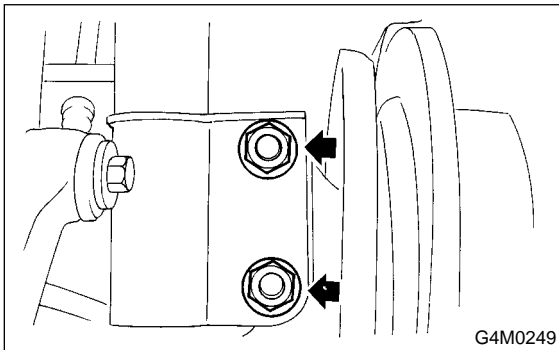

B: INSTALLATION

S301154A11

1. DISC BRAKE

S301154A1102

- 1) Connect rear housing assembly and strut assembly.

CAUTION:

Use a new self-locking nut.

Tightening torque:

196 N·m (20 kgf·m, 145 ft·lb)

- 2) Fit BJ (bell joint) to rear housing splines.

CAUTION:

Be careful not to damage inner oil seal lip.

- 3) Connect rear housing assembly to lateral link assembly.

CAUTION:

Use a new self-locking nut.

Tightening torque:

137 N·m (14 kgf·m, 101 ft·lb)

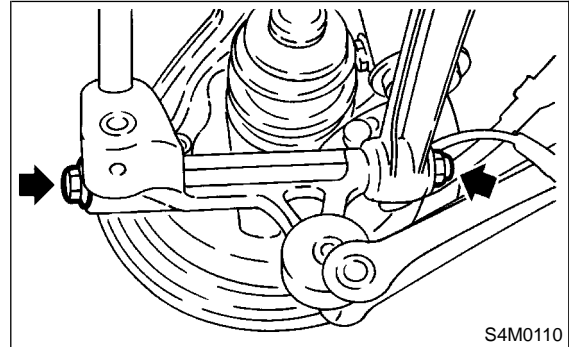

- 4) Connect rear housing assembly to trailing link assembly.

CAUTION:

Use a new self-locking nut.

Tightening torque:

113 N·m (11.5 kgf·m, 83 ft·lb)

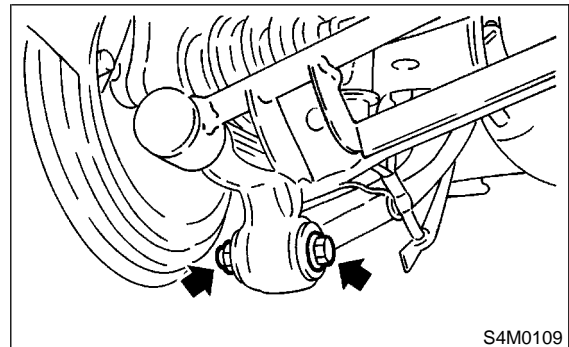

- 5) Connect rear stabilizer to rear lateral link.

CAUTION:

Use a new self-locking nut.

Tightening torque:

44 N·m (4.5 kgf·m, 32.5 ft·lb)

- 6) Connect parking brake cable to parking brake.
- 7) Install disc rotor on rear housing assembly.

8) Install disc brake caliper on back plate.

Tightening torque:

52 N·m (5.3 kgf-m, 38.3 ft-lb)

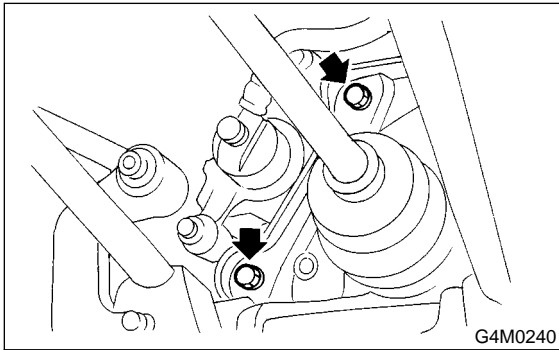

9) Install rear ABS sensor to back plate (only vehicle equipped with ABS).

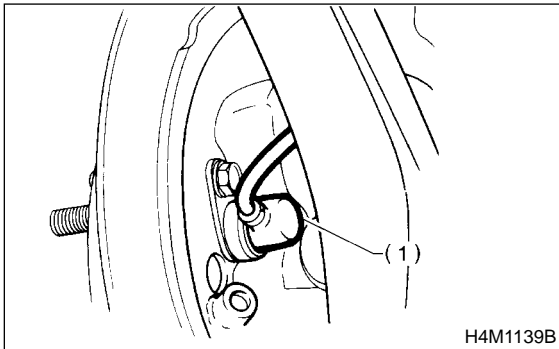

(1) ABS sensor

10) Bleed air from brake system. <Ref. to BR-47, Air Bleeding.>

11) Adjust parking brake lever stroke by turning adjuster.

12) Move brake lever back to apply brakes. While depressing brake pedal, tighten axle nut using a socket wrench. Lock axle nut after tightening.

Tightening torque:

186 N·m (19 kgf-m, 137 ft-lb)

CAUTION:

- Use a new axle nut.
- Always tighten axle nut before installing wheel on vehicle. If wheel is installed and comes in contact with ground when axle nut is loose, wheel bearings may be damaged.
- Be sure to tighten axle nut to specified torque. Do not overtighten it as this may damage wheel bearing.

13) Install wheel and tighten wheel nuts to specified torque.

Tightening torque:

88 N·m (9 kgf-m, 65 ft-lb)

2. DRUM BRAKE S301154A1103

1) Connect rear housing assembly and strut assembly.

CAUTION:

Use a new self-locking nut.

Tightening torque:

196 N·m (20 kgf-m, 145 ft-lb)

2) Fit BJ (bell joint) to rear housing splines.

CAUTION:

Be careful not to damage inner oil seal lip.

3) Connect rear housing assembly to lateral link assembly.

CAUTION:

Use a new self-locking nut.

Tightening torque:

137 N·m (14 kgf-m, 101 ft-lb)

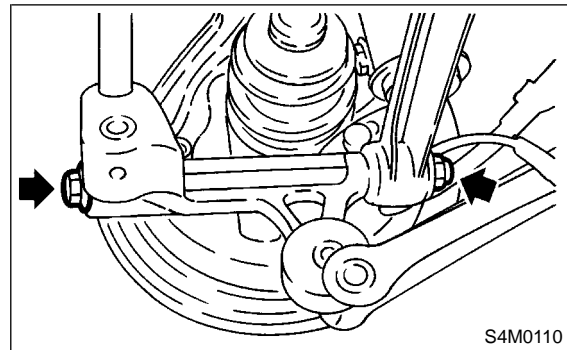

4) Connect rear housing assembly to trailing link assembly.

CAUTION:

Use a new self-locking nut.

Tightening torque:

113 N·m (11.5 kgf-m, 83 ft-lb)

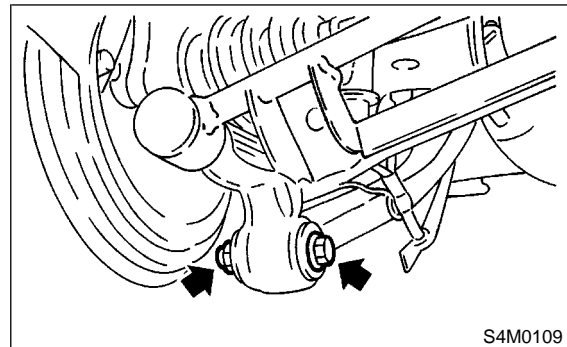

5) Connect rear stabilizer to rear lateral link.

CAUTION:

Use a new self-locking nut.

Tightening torque:

44 N·m (4.5 kgf-m, 32.5 ft-lb)

6) Connect parking brake cable to parking brake.

REAR AXLE

Drive Shaft System

- 7) Clean brake pipe connection. Using a flare-nut wrench, connect brake pipe to wheel cylinder.
- 8) Connect rear ABS sensor to back plate (only vehicle equipped with ABS).

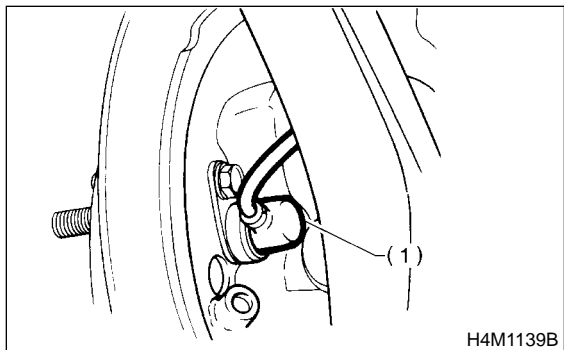

(1) ABS sensor

- 9) Connect parking brake cable to lever.
- 10) Install brake drum on rear housing assembly.
- 11) Bleed air from brake system. <Ref. to BR-47, Air Bleeding.>
- 12) Adjust parking brake lever stroke by turning adjuster.
- 13) Move brake lever back to apply brakes. While depressing brake pedal, tighten axle nut using a socket wrench. Lock axle nut after tightening.

Tightening torque:

186 N·m (19 kgf·m, 137 ft·lb)

CAUTION:

- Use a new axle nut.
- Always tighten axle nut before installing wheel on vehicle. If wheel is installed and comes in contact with ground when axle nut is loose, wheel bearings may be damaged.
- Be sure to tighten axle nut to specified torque. Do not overtighten it as this may damage wheel bearing.

- 14) Install wheel and tighten wheel nuts to specified torque.

Tightening torque:

88 N·m (9 kgf·m, 65 ft·lb)

C: DISASSEMBLY S301154A06

- 1) Using ST1 and ST2, remove hub from rear housing.

ST1 927080000 HUB STAND
ST2 927420000 HUB REMOVER

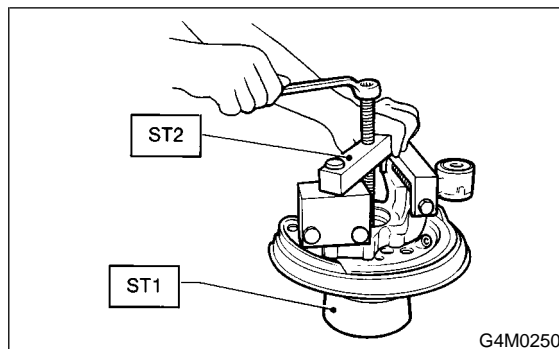

- 2) Remove back plate from rear housing.
- 3) Using a standard screwdriver, remove outer and inner oil seals.

CAUTION:

Use new oil seals.

- 4) Using flat bladed screwdriver, remove snap ring.

CAUTION:

Remove without scratching axle housing.

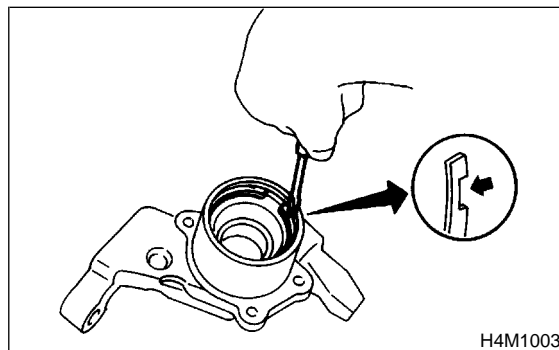

5) Using ST1 and ST2, remove bearing by pressing inner race.

ST1 927430000 HOUSING STAND
ST2 927440000 BEARING REMOVER

CAUTION:

- Do not remove bearing unless damaged.
- Do not re-use bearing after removal.

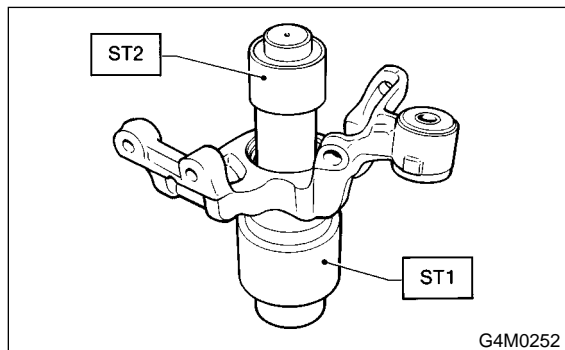

6) Remove tone wheel bolts and remove tone wheel from hub (only vehicle equipped with ABS).

7) Using ST, press hub bolt out.
ST 927080000 HUB STAND

CAUTION:

Be careful not to hammer hub bolts. This may deform hub.

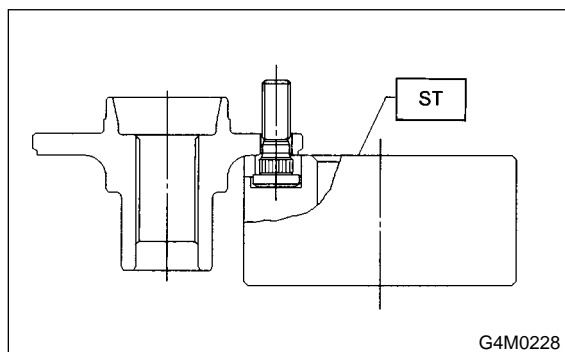

D: ASSEMBLY S301154A02

1) Using ST, press new hub bolt into place.

CAUTION:

- Ensure hub bolt closely contacts hub.
- Use a 12 mm (0.47 in) hole in the ST to prevent hub bolt from tilting during installation.

ST 927080000 HUB STAND

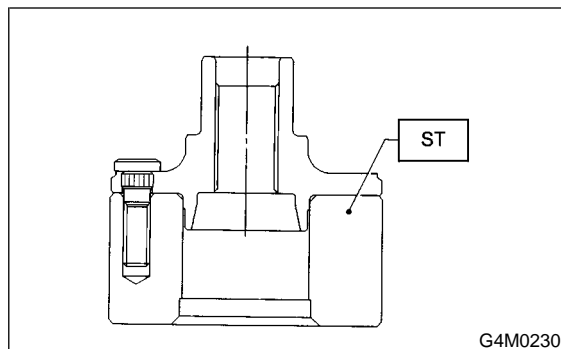

2) Remove foreign particles (dust, rust, etc.) from mating surfaces of hub and tone wheel, and install tone wheel to hub (only vehicle equipped with ABS).

CAUTION:

- Ensure tone wheel closely contacts hub.
- Be careful not to damage tone wheel teeth.

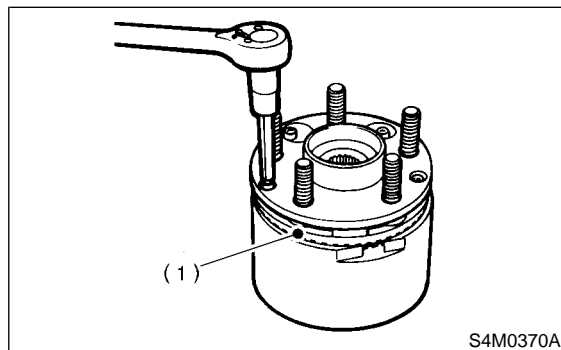

(1) Tone wheel

REAR AXLE

Drive Shaft System

3) Clean housing interior completely. Using ST1 and ST2, press bearing into housing.

ST1 927430000 HOUSING STAND

ST2 927440000 BEARING REMOVER

CAUTION:

- Always press outer race when installing bearing.
- Be careful not to remove plastic lock from inner race when installing bearing.
- Charge bearing with new grease when outer race is not removed.

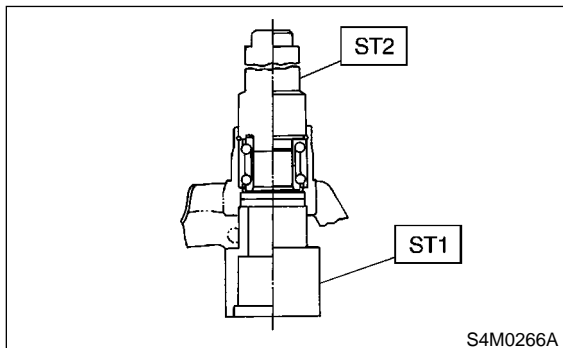

4) Using plier, install snap ring.

CAUTION:

- Ensure snap ring fits in groove properly.
- Install without scratching axle housing.

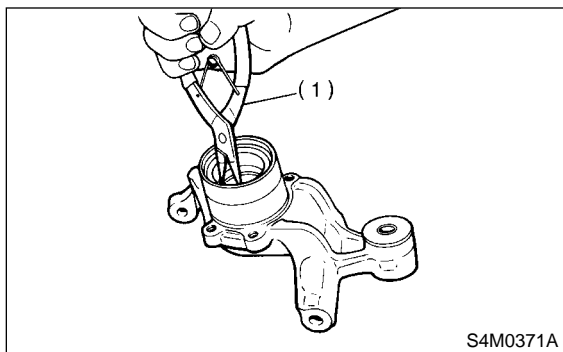

(1) Plier

5) Using ST1 and ST2, press outer oil seal until it comes in contact with snap ring.

ST1 927430000 HOUSING STAND

ST2 927460000 OIL SEAL INSTALLER

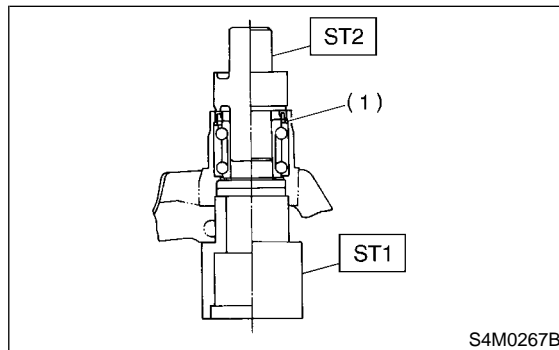

(1) Snap ring

6) Invert both ST1 and housing.

7) Using ST2, press inner oil seal into housing until it touches bottom.

ST1 927430000 HOUSING STAND

ST2 927460000 OIL SEAL INSTALLER

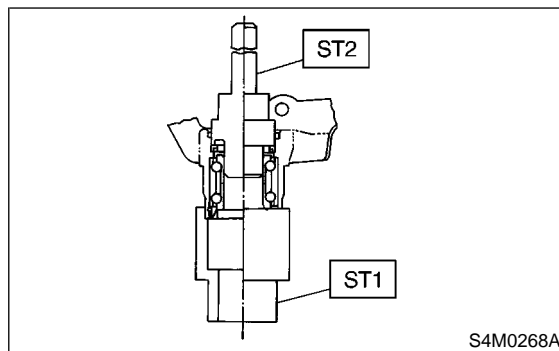

8) Using ST1 and ST2, press sub seal into place.

ST1 927430000 HOUSING STAND

ST2 927460000 OIL SEAL INSTALLER

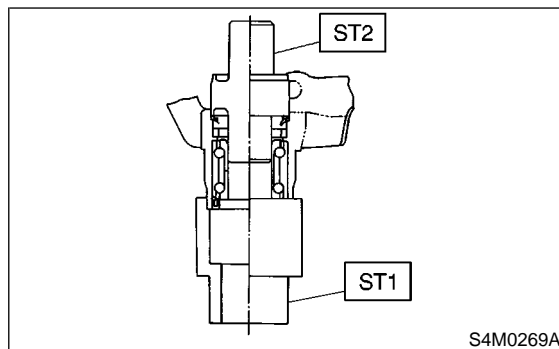

9) Apply sufficient grease to oil seal lip.

Specified grease:

SHELL 6459N

CAUTION:

- If specified grease is not available, remove bearing grease and apply Auto Rex A instead.
- Do not mix different types of grease.

10) Install back plate to rear housing.

Tightening torque:

52 N·m (5.3 kgf-m, 38 ft-lb)

11) Using ST1 and ST2, press bearing into hub.

ST1 927080000 HUB STAND

ST2 927450000 HUB INSTALLER

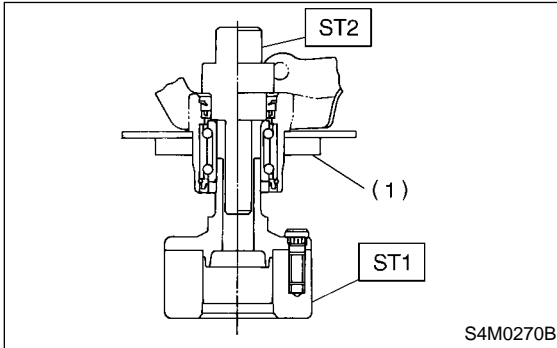

(1) Back plate

E: INSPECTION S301154A10

1) Check that there is no backlash in the rear bearing as well as front. And check that wheel rotates smoothly. <Ref. to DS-22, INSPECTION, Front Axle.>

2) Inspect the removed parts for wear and damage. If defective, replace with a new one.

CAUTION:

- If a bearing is faulty, replace it as the bearing set.
- Be sure to replace oil seal at every overhaul.

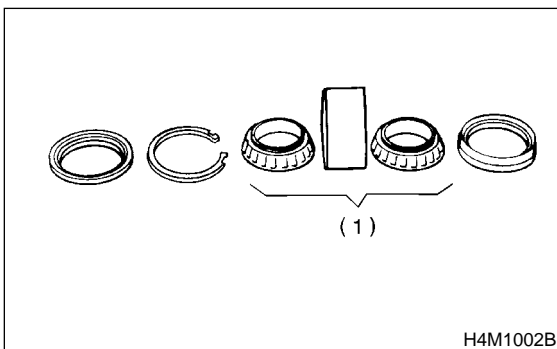

(A) Replace as a set.

FRONT DRIVE SHAFT

Drive Shaft System

5. Front Drive Shaft S301153

A: REMOVAL S301153A18

- 1) Disconnect ground terminal from battery.
- 2) Jack-up vehicle, support it with safety stands (rigid rocks), and remove front wheel cap and wheels.
- 3) Unlock axle nut.
- 4) Depress brake pedal and remove axle nut using a socket wrench.

CAUTION:

Be sure to loosen and retighten axle nut after removing wheel from vehicle. Failure to follow this rule may damage wheel bearings.

- 5) Remove stabilizer link from transverse link.
- 6) Disconnect transverse link from housing.
- 7) Remove spring pin which secures transmission spindle to SFJ.

CAUTION:

Use a new spring pin.

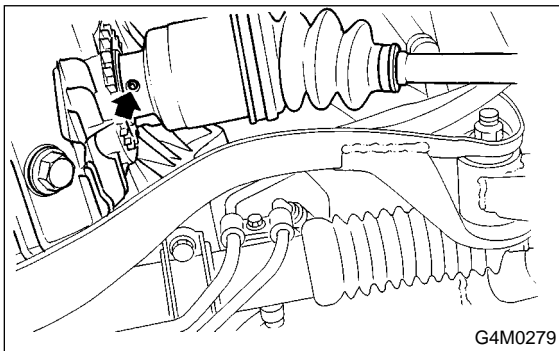

- 8) Remove front drive shaft assembly. If it is hard to remove, use ST1 and ST2.

ST1 926470000 AXLE SHAFT PULLER
ST2 927140000 PLATE

CAUTION:

- Be careful not to damage oil seal lip and tone wheel when removing front drive shaft.
- When front drive shaft is to be replaced, also replace inner oil seal.

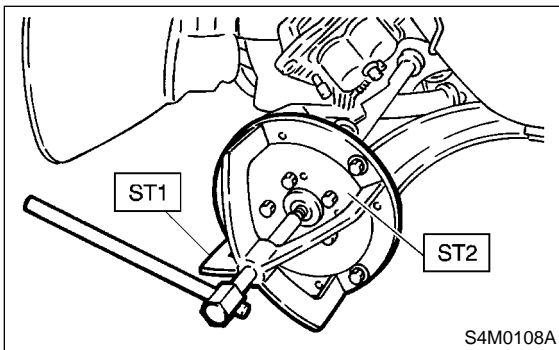

B: INSTALLATION S301153A11

- 1) Insert BJ into hub splines.

CAUTION:

Be careful not to damage inner oil seal lip and tone wheel.

- 2) Using ST1 and ST2, pull drive shaft into place.
ST1 922431000 AXLE SHAFT INSTALLER
ST2 927390000 ADAPTER

CAUTION:

Do not hammer drive shaft when installing it.

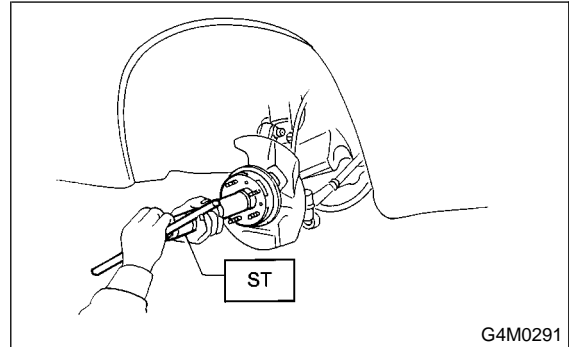

- 3) Tighten axle nut temporarily.
- 4) Install SFJ on transmission spindle and drive spring pin into place.

CAUTION:

Always use a new spring pin.

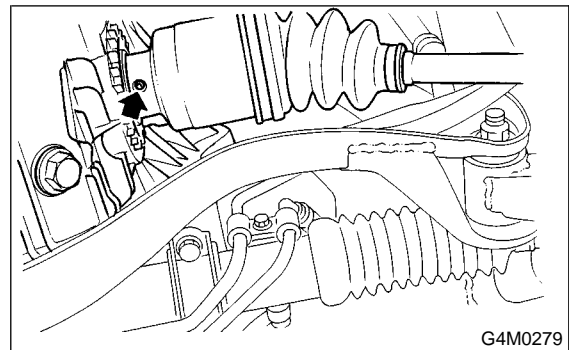

- 5) Connect transverse link to housing.

Tightening torque (self-locking nut):
49 N-m (5.0 kgf-m, 36 ft-lb)

CAUTION:

Use a new self-locking nut.

- 6) Install stabilizer bracket.
- 7) While depressing brake pedal, tighten axle nut to the specified torque.

Tightening torque:
186 N-m (19 kgf-m, 137 ft-lb)

CAUTION:

- Use a new axle nut.
- Always tighten axle nut before installing wheel on vehicle. If wheel is installed and comes in contact with ground when axle nut is loose, wheel bearings may be damaged.
- Be sure to tighten axle nut to specified torque. Do not overtighten it as this may damage wheel bearing.

8) After tightening axle nut, lock it securely.

C: DISASSEMBLY

S301153A06

1) Place alignment marks on shaft and outer race.

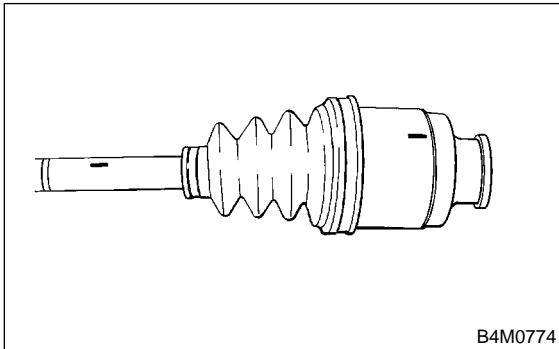

B4M0774

2) Remove SFJ boot band and boot.

CAUTION:

Be careful not to damage boot.

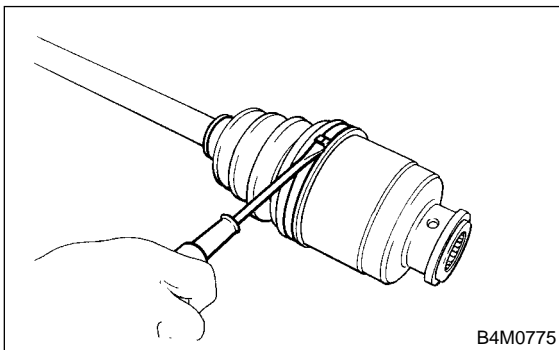

B4M0775

3) Remove circlip from SFJ outer race using screwdriver.

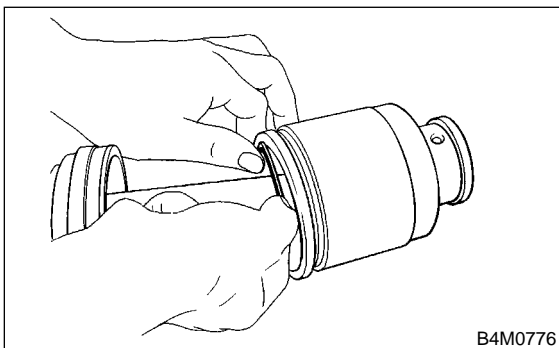

B4M0776

4) Remove SFJ outer race from shaft assembly.
5) Wipe off grease.

CAUTION:

The grease is a special grease. Do not confuse with other greases.

6) Place alignment mark on free ring and trunnion.

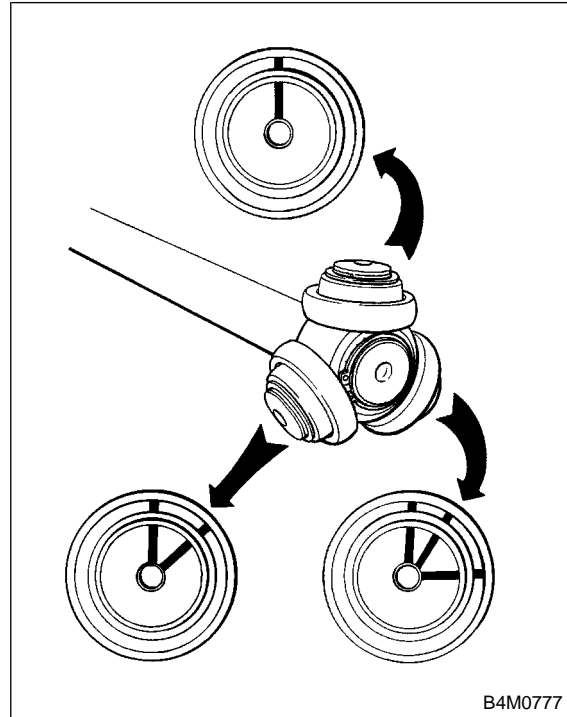

B4M0777

7) Remove free ring from trunnion.

CAUTION:

Be careful with the free ring position.

8) Place alignment mark on trunnion and shaft.

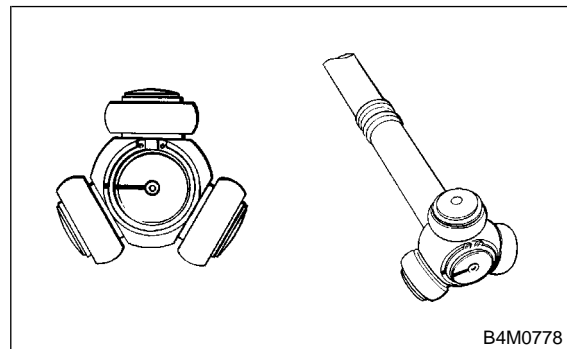

B4M0778

9) Remove snap ring and trunnion.

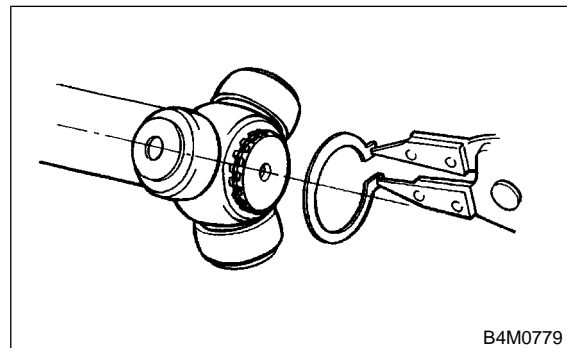

B4M0779

FRONT DRIVE SHAFT

Drive Shaft System

CAUTION:

Be sure to wrap shaft splines with vinyl tape to prevent boot from scratches.

- 10) Remove SFJ boot.
- 11) Place drive shaft in a vise between wooden blocks.

CAUTION:

Do not place drive shaft directly in the vise; use wooden block.

- 12) Raise boot band claws by means of screwdriver and hammer.

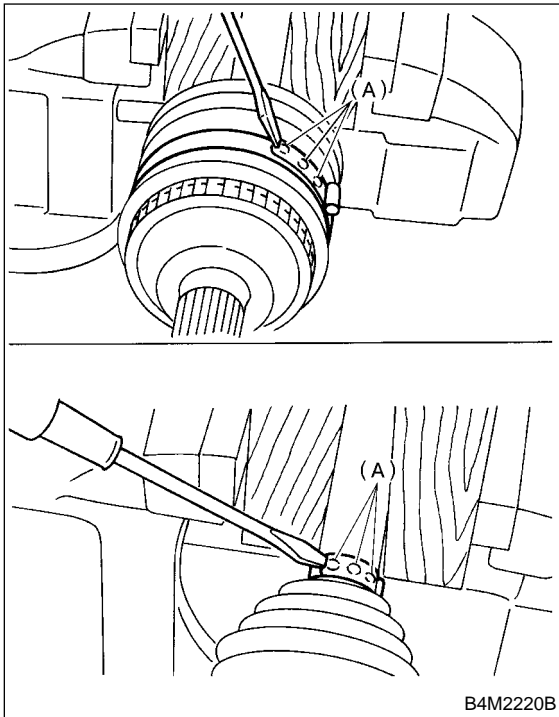

(A) Boot band claws

- 13) Cut and remove the boot.

CAUTION:

The boot must be replaced with a new one whenever it is removed.

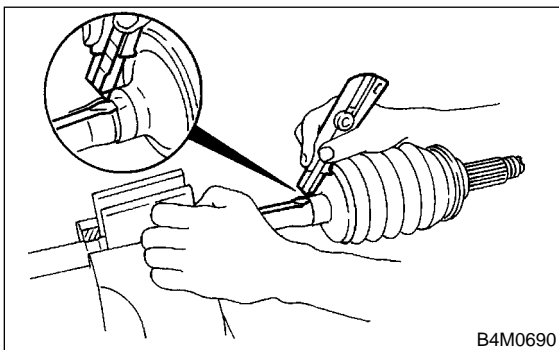

- 14) Thus, disassembly of axle is completed, but BJ cannot be disassembled.

D: ASSEMBLY

S301153A02

CAUTION:

Use specified grease.

BJ side:

NTG2218 (Part No. 28093AA000)

SFJ side:

SSG6003 (Part No. 28093TA000)

- 1) Place BJ boot and small boot band on BJ side of shaft.

CAUTION:

Be sure to wrap shaft splines with vinyl tape to prevent boot from scratches.

- 2) Place drive shaft in a vise.

CAUTION:

Do not place drive shaft directly in the vise; use wooden blocks.

- 3) Apply a coat of specified grease [60 to 70 g (2.12 to 2.47 oz)] to BJ.
- 4) Apply an even coat of specified grease [20 to 30 g (0.71 to 1.06 oz)] to the entire inner surface of boot. Also apply grease to shaft.

NOTE:

The inside of the larger end of BJ boot and the boot groove shall be cleaned so as to be free from grease and other substances.

- 5) Install boot projecting portion to BJ groove.

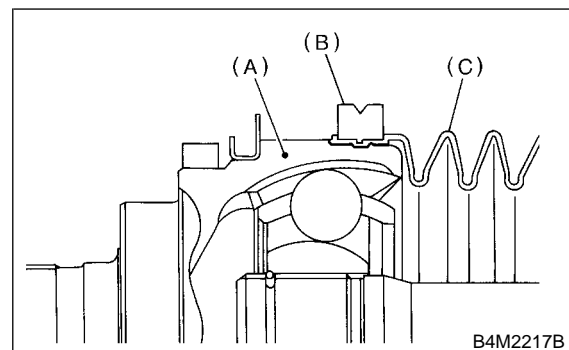

(A) BJ
(B) Large boot band
(C) Boot

- 6) Set large boot band in place.

7) Install boot projecting portion to shaft groove.

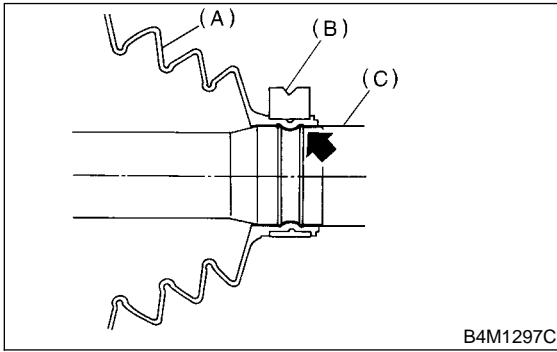

B4M1297C

- (A) Boot
- (B) Small boot band
- (C) Shaft

8) Tighten boot bands using ST, torque wrench and socket flex handle.

ST 28099AC000 BOOT BAND PLIER

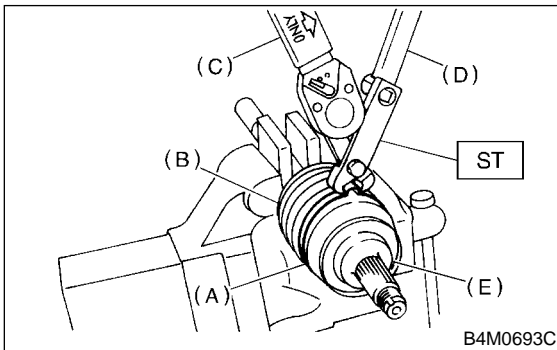

B4M0693C

- (A) Large boot band
- (B) Boot
- (C) Torque wrench
- (D) Socket flex handle
- (E) BJ

Tightening torque:

Large boot band

157 N·m (16.0 kgf·m, 116 ft·lb) or more

Small boot band

133 N·m (13.6 kgf·m, 98 ft·lb) or more

9) Place SFJ boot at the center of shaft.
10) Align alignment marks and install trunnion on shaft.

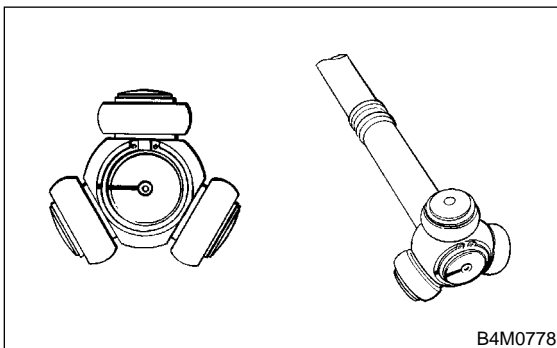

B4M0778

11) Install snap ring to shaft.

CAUTION:

Confirm that the snap ring is completely fitted in the shaft groove.

12) Fill 100 to 110 g (3.53 to 3.88 oz) of specified grease into the interior of SFJ outer race.

13) Apply a coat of specified grease to free ring and trunnion.

14) Align alignment marks on free ring and trunnion and install free ring.

CAUTION:

Be careful with the free ring position.

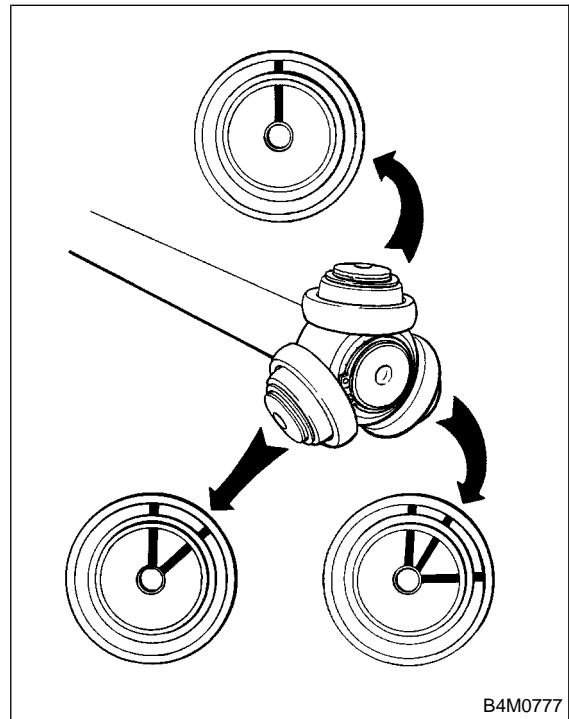

B4M0777

15) Align alignment marks on shaft and outer race, and install outer race.

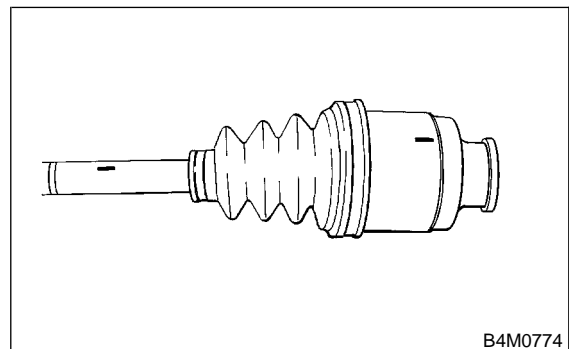

B4M0774

16) Install circlip in the groove on SFJ outer race.

CAUTION:

Pull the shaft lightly and assure that the circlip is completely fitted in the groove.

FRONT DRIVE SHAFT

Drive Shaft System

17) Apply an even coat of the specified grease 30 to 40 g (1.06 to 1.41 oz) to the entire inner surface of boot.

18) Install SFJ boot taking care not to twist it.

CAUTION:

- The inside of the larger end of SFJ boot and the boot groove shall be cleaned so as to be free from grease and other substances.
- When installing SFJ boot, position outer race of SFJ at center of its travel.

19) Put a band through the clip and wind twice in alignment with band groove of boot.

CAUTION:

Use a new band.

20) Pinch the end of band with pliers. Hold the clip and tighten securely.

NOTE:

When tightening boot, exercise care so that the air within the boot is appropriate.

21) Tighten band by using ST.

ST 925091000 BAND TIGHTENING TOOL

NOTE:

Tighten band until it cannot be moved by hand.

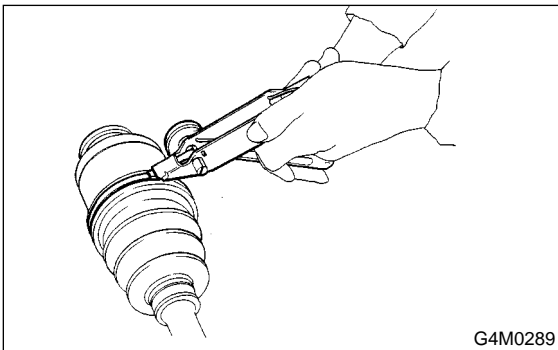

22) Tap on the clip with the punch provided at the end of ST.

ST 925091000 BAND TIGHTENING TOOL

CAUTION:

Tap to an extent that the boot underneath is not damaged.

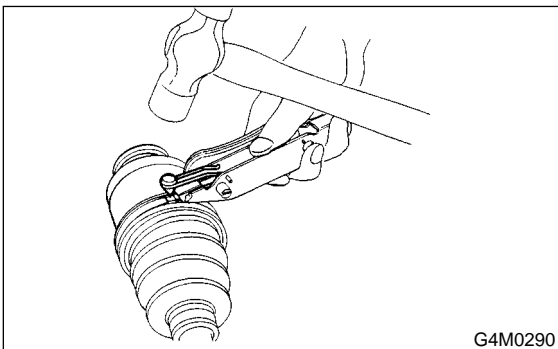

23) Cut off band with an allowance of about 10 mm (0.39 in) left from the clip and bend this allowance over the clip.

CAUTION:

Be careful so that the end of the band is in close contact with clip.

24) Fix up boot on BJ in the same manner.

NOTE:

Extend and retract SFJ to provide equal grease coating.

E: INSPECTION S301153A10

Check the removed parts for damage, wear, corrosion etc. If faulty, repair or replace.

1) DOJ (Double Offset Joint)

Check seizure, corrosion, damage, wear and excessive play.

2) SFJ (Shudder-less Freering tripod Joint)

Check seizure, corrosion, damage and excessive play.

3) Shaft

Check excessive bending, twisting, damage and wear.

4) BJ (Bell Joint)

Check seizure, corrosion, damage and excessive play.

5) Boot

Check for wear, warping, breakage or scratches.

6) Grease

Check for discoloration or fluidity.

6. Front Drive Shaft Boot S301755

A: INSPECTION S301755A10

Check boot for deterioration, deform and damage.
If any fault is found, replace the boot.

B: REPLACEMENT S301755A20

- 1) Set vehicle on a lift.
- 2) Disconnect ground terminal from battery.
- 3) Jack-up vehicle, support it with safety stands (rigid rocks), and remove front wheel cap and wheels.

NOTE:

Do not remove axle nut.

- 4) Remove stabilizer link.
- 5) Disconnect transverse link from housing.
- 6) Remove spring pin which secures transmission spindle to SFJ.

CAUTION:

Use a new spring pin.

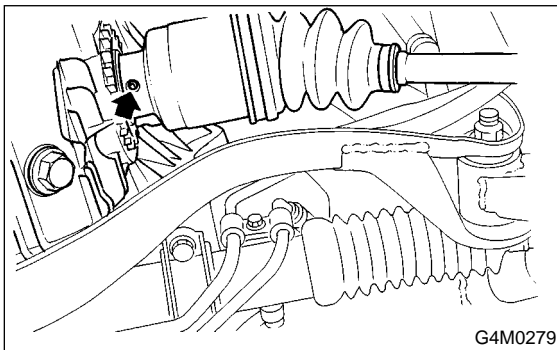

- 7) Remove BJ and SFJ boots from drive shaft.
<Ref. to DS-33, DISASSEMBLY, Front Drive Shaft.>
- 8) Install BJ and SFJ boots to drive shaft.
<Ref. to DS-34, ASSEMBLY, Front Drive Shaft.>
- 9) Install SFJ on transmission spindle and drive spring pin into place.

CAUTION:

Always use a new spring pin.

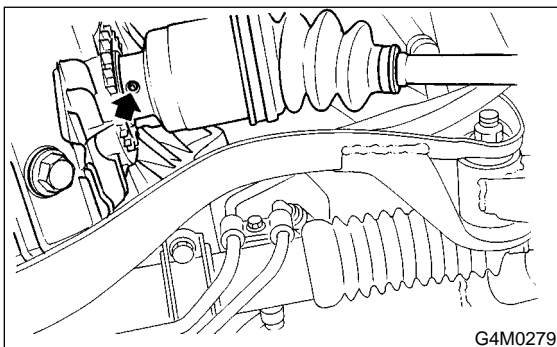

- 10) Connect transverse link to housing.
- 11) Install stabilizer link.

REAR DRIVE SHAFT

Drive Shaft System

7. Rear Drive Shaft S301156

A: REMOVAL S301156A18

- 1) Set vehicle on a lift.
- 2) Disconnect ground cable from battery.
- 3) Lift vehicle. Remove rear wheel cap and wheels.

CAUTION:

Be sure to loosen and retighten axle nut after removing wheel from vehicle. Failure to follow this rule may damage wheel bearings.

- 4) Unlock axle nut.
- 5) Loosen axle nut using a socket wrench.

CAUTION:

Do not remove axle nut.

- 6) Remove ABS sensor clamps and parking brake cable bracket.
- 7) Remove bolts which secure lateral link assembly to rear housing.

CAUTION:

Discard old self-locking nut. Replace with a new one.

- 8) Remove bolts which secure trailing link assembly to rear housing.

CAUTION:

Discard old self-locking nut. Replace with a new one.

- 9) Remove DOJ from rear differential using ST. (Except Non-TURBO AT vehicle)
ST 28099PA100 DRIVE SHAFT REMOVER

CAUTION:

Do not remove circlip attached to inside of differential.

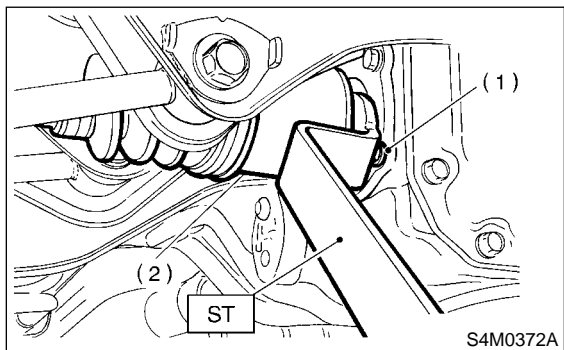

- (1) Bolt
- (2) DOJ

CAUTION:

Be careful not to damage side bearing retainer. Always use bolt as shown in figure, as supporting point for ST during removal.

ST 28099PA100 DRIVE SHAFT REMOVER

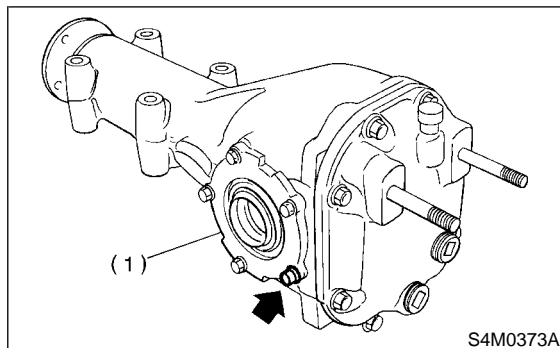

- (1) Side bearing retainer

- 10) Remove DOJ from rear differential using tire lever. (Non-TURBO AT vehicles)

NOTE:

The side spline shaft circlip comes out together with the shaft.

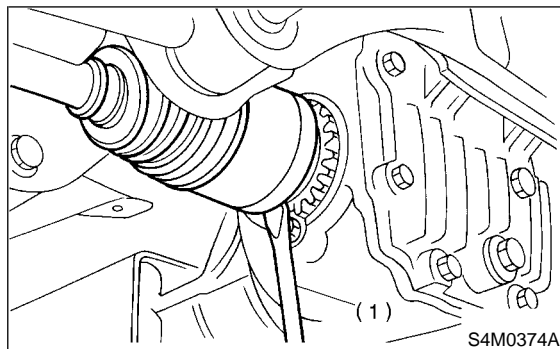

- (1) Tire lever

CAUTION:

When removing the DOJ from the rear differential, fit tire lever to the bolt as shown in figure so as not to damage the axle shaft holder.

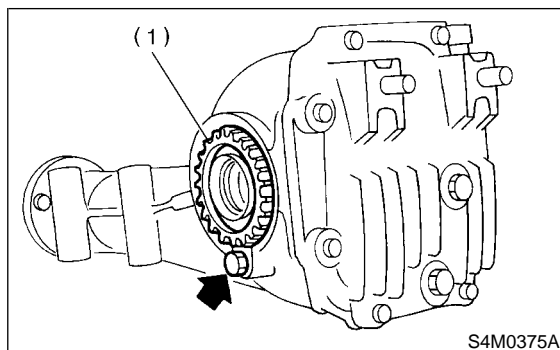

- (1) Axle shaft holder

11) Remove axle nut and drive shaft. If it is hard to remove, use ST1 and ST2.

ST1 926470000 AXLE SHAFT PULLER

ST2 927140000 PLATE

CAUTION:

- Be careful not to damage oil seal lip when removing rear drive shaft.
- When rear drive shaft is to be replaced, also replace inner oil seal with a new one.

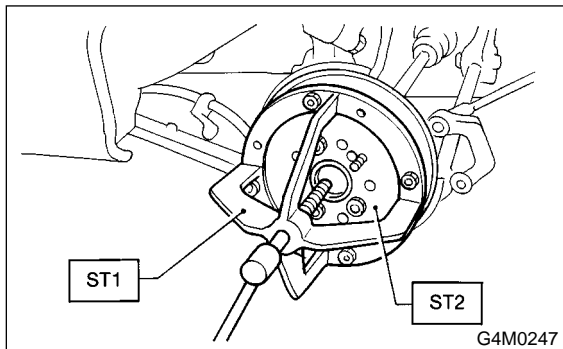

B: INSTALLATION

S301156A11

1) Insert BJ into rear housing splines.

CAUTION:

Be careful not to damage inner oil seal lip.

2) Using ST1 and ST2, pull drive shaft into place.

ST1 922431000 AXLE SHAFT INSTALLER

ST2 927390000 ADAPTER

CAUTION:

Do not hammer drive shaft when installing it.

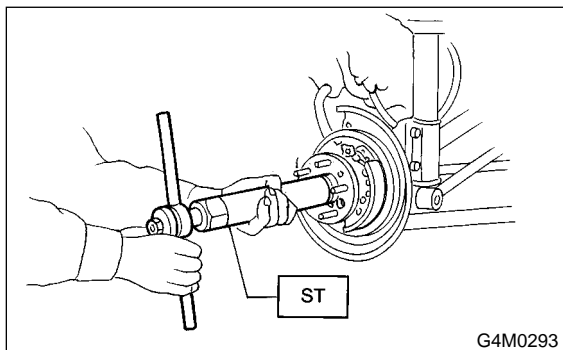

3) Tighten axle nut temporarily.

4) Replace circlips from DOJ spline with new one.

5) Using ST, install DOJ into differential.

ST 28099PA090 SIDE OIL SEAL PROTECTOR

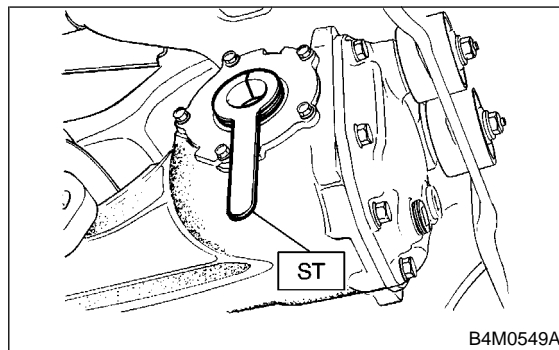

6) Insert DOJ spline end into bore of side oil seal, and remove ST.

CAUTION:

Do not allow DOJ splines to damage side oil seal.

ST 28099PA090 SIDE OIL SEAL PROTECTOR

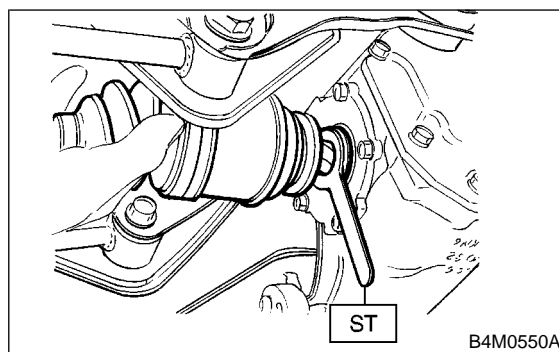

7) Align DOJ and differential splines.

8) Push housing to insert DOJ into differential.

NOTE:

Make sure DOJ is inserted properly.

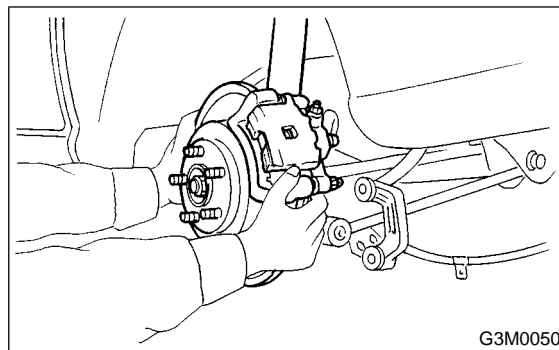

9) Connect rear housing assembly to trailing link assembly, and tighten self-locking nut.

Tightening torque:

113 N·m (11.5 kgf·m, 83 ft·lb)

10) Connect rear housing assembly to lateral link assembly, and tighten self-locking nut.

REAR DRIVE SHAFT

Drive Shaft System

Tightening torque:

137 N·m (14 kgf·m, 101 ft·lb)

- 11) Install stabilizer bracket.
- 12) While depressing brake pedal, tighten axle nut using a socket wrench.

Tightening torque:

186 N·m (19 kgf·m, 137 ft·lb)

CAUTION:

- Use a new axle nut.
- Always tighten axle nut before installing wheel on vehicle. If wheel is installed and comes in contact with ground when axle nut is loose, wheel bearings may be damaged.
- Be sure to tighten axle nut to specified torque. Do not overtighten it as this may damage wheel bearing.

- 13) After tightening axle nut, lock it securely.

C: DISASSEMBLY S301156A06

- 1) Straighten bent claw of larger end of DOJ boot.
- 2) Loosen band by means of screwdriver or pliers with care of not damaging boot.

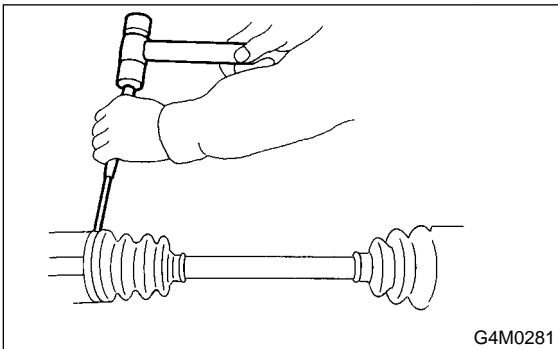

- 3) Remove boot band on the small end of DOJ boot in the same manner.
- 4) Remove the larger end of DOJ boot from DOJ outer race.
- 5) Pry and remove round circlip located at the neck of DOJ outer race with a screwdriver.

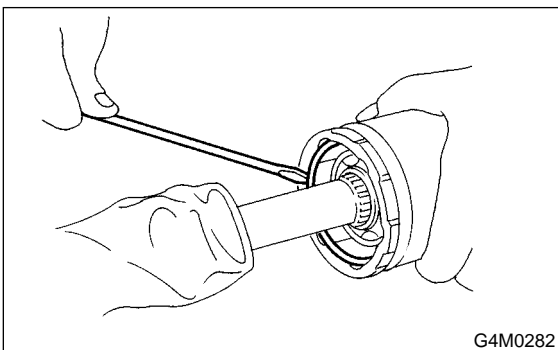

- 6) Take out DOJ outer race from shaft assembly.
- 7) Wipe off grease and take out balls.

CAUTION:

The grease is a special grease (grease for constant velocity joint). Do not confuse with other greases.

NOTE:

Disassemble exercising care not to lose balls (6 pcs).

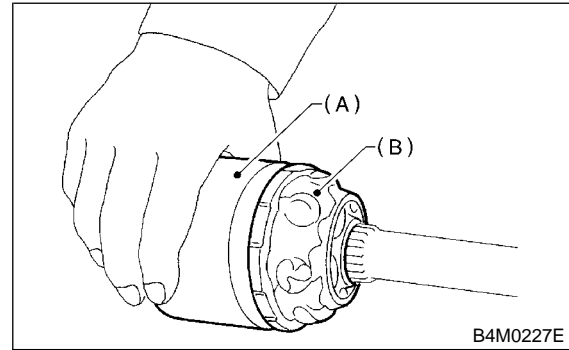

- (A) Outer race
(B) Grease

- 8) To remove the cage from the inner race, turn the cage by a half pitch to the track groove of the inner race and shift the cage.
- 9) Remove snap ring, which fixes inner race to shaft, by using pliers.
- 10) Take out DOJ inner race.
- 11) Take off DOJ cage from shaft and remove DOJ boot.

CAUTION:

Be sure to wrap shaft splines with vinyl tape to prevent boot from scratches.

- 12) Remove BJ boot in the same procedure as DOJ boot.
- 13) Thus, disassembly of axle is completed, but BJ is unable to be disassembled.

D: ASSEMBLY S301156A02

CAUTION:

Use specified grease.

BJ side (Non-turbo model):

Molylex No. 2 (Part No. 723223010)

EBJ side (Turbo model):

NTG 2218 (Part No. 28093AA000)

DOJ side:

VU-3A702 (Yellow) (Part No. 23223GA050)

- 1) Install BJ or EBJ boot in specified position, and fill it with 60 to 70 g (2.12 to 2.47 oz) of specified grease.
- 2) Place DOJ boot at the center of shaft.

CAUTION:

Be sure to wrap shaft splines with vinyl tape to prevent boot from scratches.

3) Insert DOJ cage onto shaft.

NOTE:

Insert the cage with the cut-out portion facing the shaft end, since the cage has an orientation.

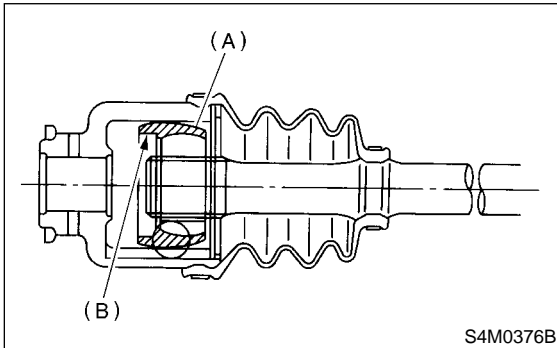

- (A) Cage
- (B) Cut-out portion

4) Install DOJ inner race on shaft and fit snap ring with pliers.

NOTE:

Confirm that the snap ring is completely fitted in the shaft groove.

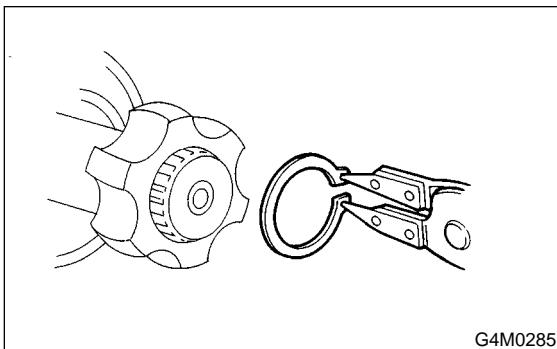

5) Install cage, which was previously fitted, to inner race fixed upon shaft.

NOTE:

Fit the cage with the protruded part aligned with the track on the inner race and then turn by a half pitch.

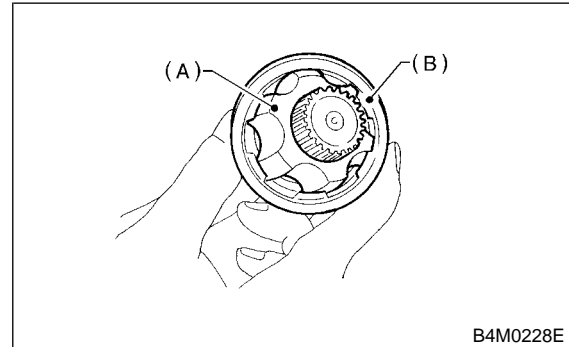

- (A) Inner race
- (B) Cage

6) Fill 80 to 90 g (2.82 to 3.17 oz) of specified grease into the interior of DOJ outer race.

7) Apply a coat of specified grease to the cage pocket and six balls.

8) Insert six balls into the cage pocket.

9) Align the outer race track and ball positions and place in the part where shaft, inner race, cage and balls are previously installed, and then fit outer race.

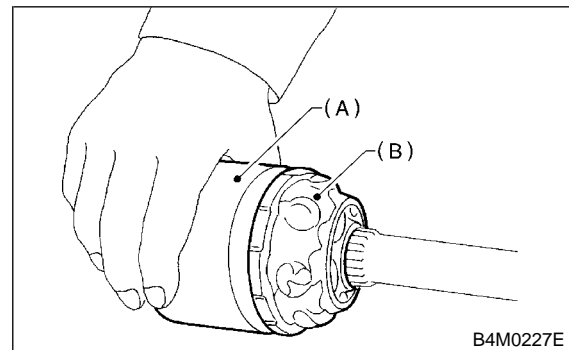

- (A) Outer race
- (B) Grease

REAR DRIVE SHAFT

Drive Shaft System

10) Install circlip in the groove on DOJ outer race.

NOTE:

- Assure that the balls, cage and inner race are completely fitted in the outer race of DOJ.
- Exercise care not to place the matched position of circlip in the ball groove of outer race.
- Pull the shaft lightly and assure that the circlip is completely fitted in the groove.

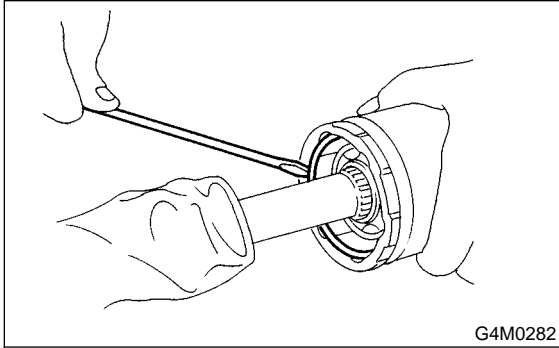

11) Apply an even coat of the specified grease [20 to 30 g (0.71 to 1.06 oz)] to the entire inner surface of boot. Also apply grease to shaft.

12) Install DOJ boot taking care not to twist it.

NOTE:

- The inside of the larger end of DOJ boot and the boot groove shall be cleaned so as to be free from grease and other substances.
- When installing DOJ boot, position outer race of DOJ at center of its travel.

13) Put a band through the clip and wind twice in alignment with band groove of boot.

CAUTION:

Use a new band.

14) Pinch the end of band with pliers. Hold the clip and tighten securely.

NOTE:

When tightening boot, exercise care so that the air within the boot is appropriate.

15) Tighten band by using ST.

ST 925091000 BAND TIGHTENING TOOL

NOTE:

Tighten band until it cannot be moved by hand.

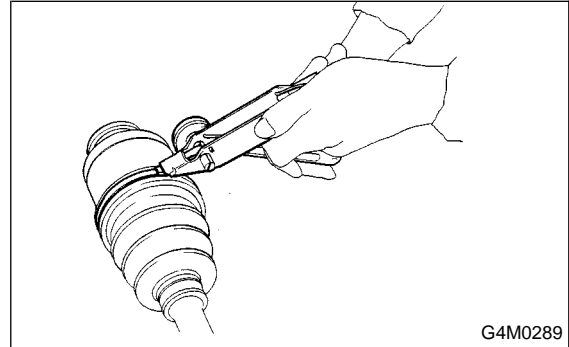

16) Tap on the clip with the punch provided at the end of ST.

ST 925091000 BAND TIGHTENING TOOL

CAUTION:

Tap to an extent that the boot underneath is not damaged.

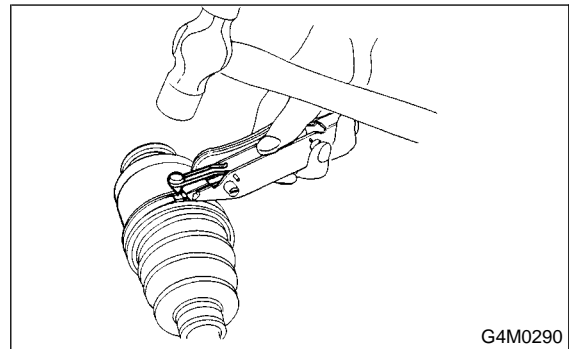

17) Cut off band with an allowance of about 10 mm (0.39 in) left from the clip and bend this allowance over the clip.

CAUTION:

Be careful so that the end of the band is in close contact with clip.

18) Fix up boot on BJ or EBJ in the same manner.

NOTE:

Extend and retract DOJ to provide equal grease coating.

E: INSPECTION S301156A10

Check the removed parts for damage, wear, corrosion etc. If faulty, repair or replace.

1) DOJ (Double Offset Joint)

Check seizure, corrosion, damage, wear and excessive play.

2) SFJ (Shudder-less Freering tripod Joint)

Check seizure, corrosion, damage and excessive play.

3) Shaft

Check excessive bending, twisting, damage and wear.

4) BJ (Bell Joint) or EBJ (High efficiency compact ball fixed joint)

Check seizure, corrosion, damage and excessive play.

5) Boot

Check for wear, warping, breakage or scratches.

6) Grease

Check for discoloration or fluidity.

REAR DRIVE SHAFT BOOT

Drive Shaft System

8. Rear Drive Shaft Boot S301756

A: INSPECTION S301756A10

Check boot for deterioration, deform and damage. If any fault is found, replace the boot.

B: REPLACEMENT S301756A20

- 1) Set vehicle on a lift.
- 2) Disconnect ground cable from battery.
- 3) Lift vehicle. Remove rear wheel cap and wheels.

NOTE:

Axle nut need not be removed.

- 4) Remove ABS sensor clamps and parking brake cable bracket.
- 5) Disconnect stabilizer link from lateral link.
- 6) Remove bolts which secure lateral link assembly to rear housing.
- 7) Remove bolts which secure trailing link assembly to rear housing.
- 8) Remove DOJ from rear differential using ST.

ST 28099PA100 DRIVE SHAFT REMOVER

NOTE:

The side spline shaft circlip comes out together with the shaft.

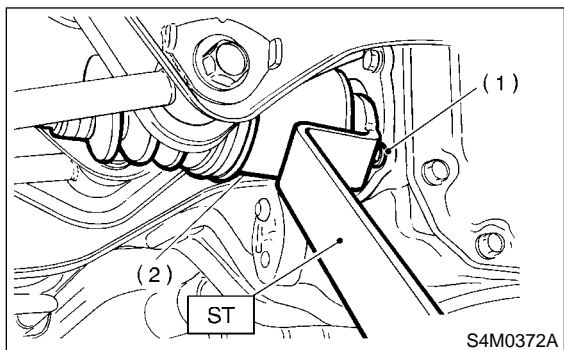

- (1) Bolt
- (2) DOJ

CAUTION:

Be careful not to damage side bearing retainer. Always use bolt as shown in figure, as supporting point for ST during removal.

ST 28099PA100 DRIVE SHAFT REMOVER

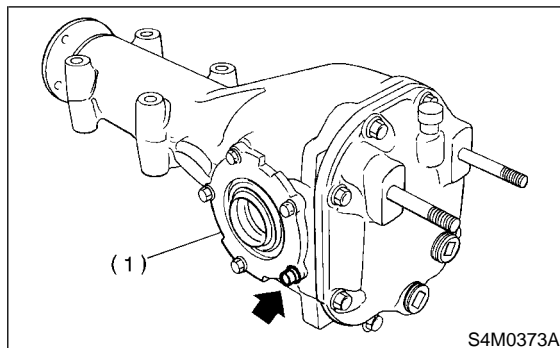

- (1) Side bearing retainer

9) Remove DOJ and BJ or EBJ boots from drive shaft. <Ref. to DS-40, DISASSEMBLY, Front Drive Shaft.>

10) Install DOJ and BJ or EBJ boots to drive shaft. <Ref. to DS-40, ASSEMBLY, Rear Drive Shaft.>

11) Using ST, install DOJ into differential.

ST 28099PA090 SIDE OIL SEAL PROTECTOR

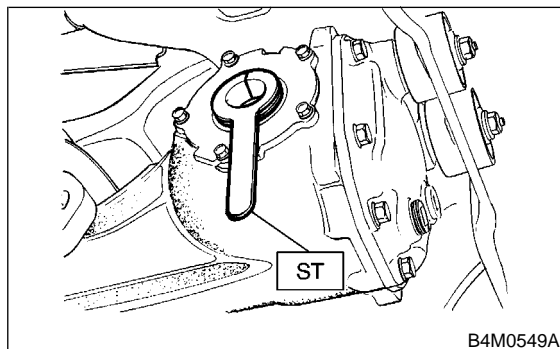

12) Insert DOJ spline end into bore of side oil seal, and remove ST.

CAUTION:

Do not allow DOJ splines to damage side oil seal.

ST 28099PA090 SIDE OIL SEAL PROTECTOR

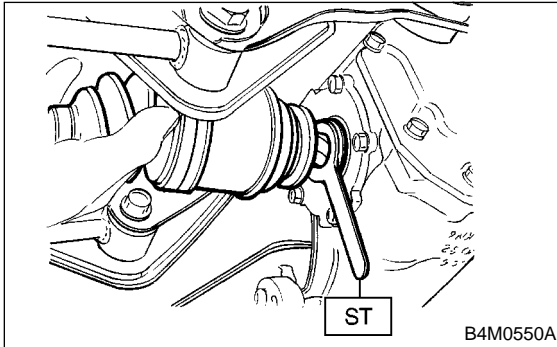

13) Align DOJ and differential splines.
14) Push housing to insert DOJ into differential.

NOTE:

Make sure DOJ is inserted properly.

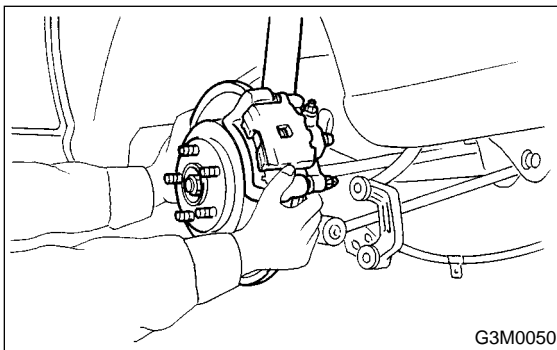

CAUTION:

Discard old self-locking nut. Replace with a new one.

- 15) Connect rear housing assembly to trailing link assembly, and tighten self-locking nut.
- 16) Connect rear housing assembly to lateral link assembly, and tighten self-locking nut.
- 17) Connect stabilizer link to lateral link.
- 18) Install ABS sensor clamps and parking brake cable bracket.

GENERAL DIAGNOSTIC TABLE

Drive Shaft System

9. General Diagnostic Table S301257

A: INSPECTION S301257A10

NOTE:

Vibration while cruising may be caused by an unbalanced tire, improper tire inflation pressure, improper wheel alignment, etc.

Symptom	Possible cause	Remedy
1. Vibration of propeller shaft NOTE: Vibration is caused by propeller shaft during operation and is transferred to vehicle body. Generally vibration increase in proportion to vehicle speed.	(1) Worn or damaged universal joint.	Replace.
	(2) Unbalanced propeller shaft due to bend or dent.	Replace.
	(3) Loose installation of propeller shaft.	Retighten.
	(4) Worn or damaged center bearing and damaged center mounting rubber.	Replace.
2. Tapping when starting and noise while cruising, caused by propeller shaft.	(1) Worn or damaged universal joint.	Replace.
	(2) Worn spline of sleeve yoke.	Replace.
	(3) Loose installation of propeller shaft.	Retighten.
	(4) Loose installation of joint.	Replace.
	(5) Worn or damaged center bearing and damaged center mounting rubber.	Replace.
3. Front wheel shimmy	(1) Worn or damaged hub bearing	Repair or replace.
4. Wander or pulling	(1) Worn or damaged hub bearing	Repair or replace.