

CHASSIS SECTION

This service manual has been prepared to provide SUBARU service personnel with the necessary information and data for the correct maintenance and repair of SUBARU vehicles.

This manual includes the procedures for maintenance, disassembling, reassembling, inspection and adjustment of components and diagnostics for guidance of experienced mechanics.

Please peruse and utilize this manual fully to ensure complete repair work for satisfying our customers by keeping their vehicle in optimum condition. When replacement of parts during repair work is needed, be sure to use SUBARU genuine parts.

All information, illustration and specifications contained in this manual are based on the latest product information available at the time of publication approval.

FUJI HEAVY INDUSTRIES LTD.

FRONT SUSPENSION FS

REAR SUSPENSION RS

WHEEL AND TIRE SYSTEM WT

DIFFERENTIALS DI

TRANSFER CASE TC

DRIVE SHAFT SYSTEM DS

ABS ABS

BRAKE BR

PARKING BRAKE PB

**POWER ASSISTED SYSTEM
(POWER STEERING)** PS

ABS (DIAGNOSTICS) ABS

PARKING BRAKE

PB

	Page
1. General Description.....	2
2. Parking Brake Lever.....	6
3. Parking Brake Cable	7
4. Parking Brake Assembly (Rear Disc Brake)	9
5. General Diagnostic Table	12



GENERAL DESCRIPTION

Parking Brake

1. General Description S404001

A: SPECIFICATIONS S404001E49

Model		Rear drum brake	Rear disc brake
Type		Mechanical on rear brakes, drum in disc	
Effective drum diameter	mm (in)	228.6 (9)	170 (6.69)
Lining dimensions (length × width × thickness)	mm (in)	218.8 × 35.0 × 4.1 (8.61 × 1.378 × 0.161)	162.6 × 30.0 × 3.2 (6.40 × 1.181 × 0.126)
Clearance adjustment		Automatic adjustment	Manual adjustment
Lever stroke	noches/N (kgf, lb)	7 to 8/196 (20, 44)	

B: COMPONENT S404001A05

1. PARKING BRAKE (REAR DISC BRAKE) S404001A0501

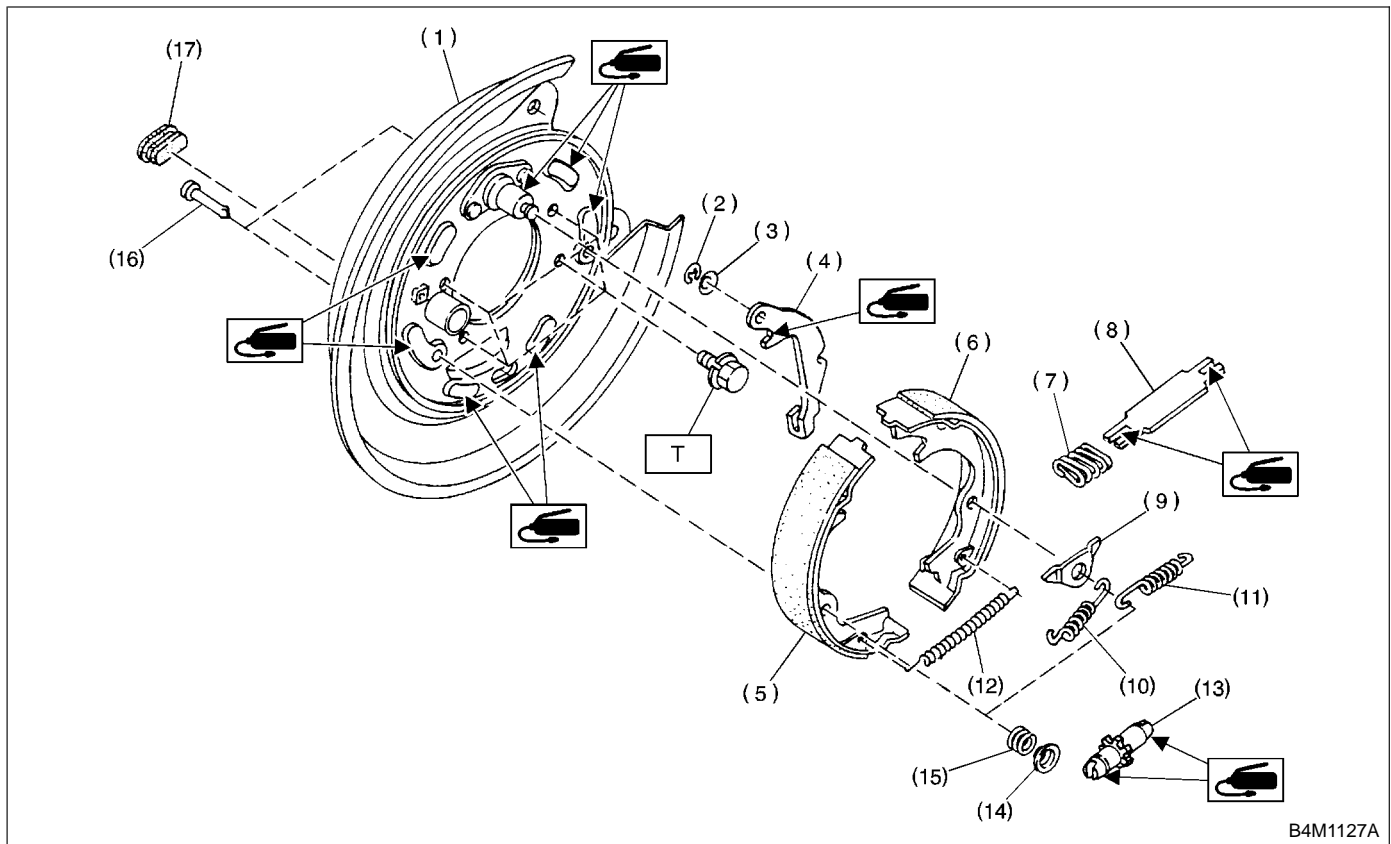

B4M1127A

- | | | |
|------------------------------------|------------------------------|----------------------------|
| (1) Back plate | (8) Strut | (15) Shoe hold down spring |
| (2) Retainer | (9) Shoe guide plate | (16) Shoe hold down pin |
| (3) Spring washer | (10) Primary return spring | (17) Adjusting hole cover |
| (4) Lever | (11) Secondary return spring | |
| (5) Parking brake shoe (Primary) | (12) Adjusting spring | |
| (6) Parking brake shoe (Secondary) | (13) Adjuster | |
| (7) Strut spring | (14) Shoe hold-down cup | |

Tightening torque: N·m (kgf·m, ft·lb)

T: 52 (5.3, 38.3)

GENERAL DESCRIPTION

Parking Brake

2. PARKING BRAKE CABLE S404001A0502

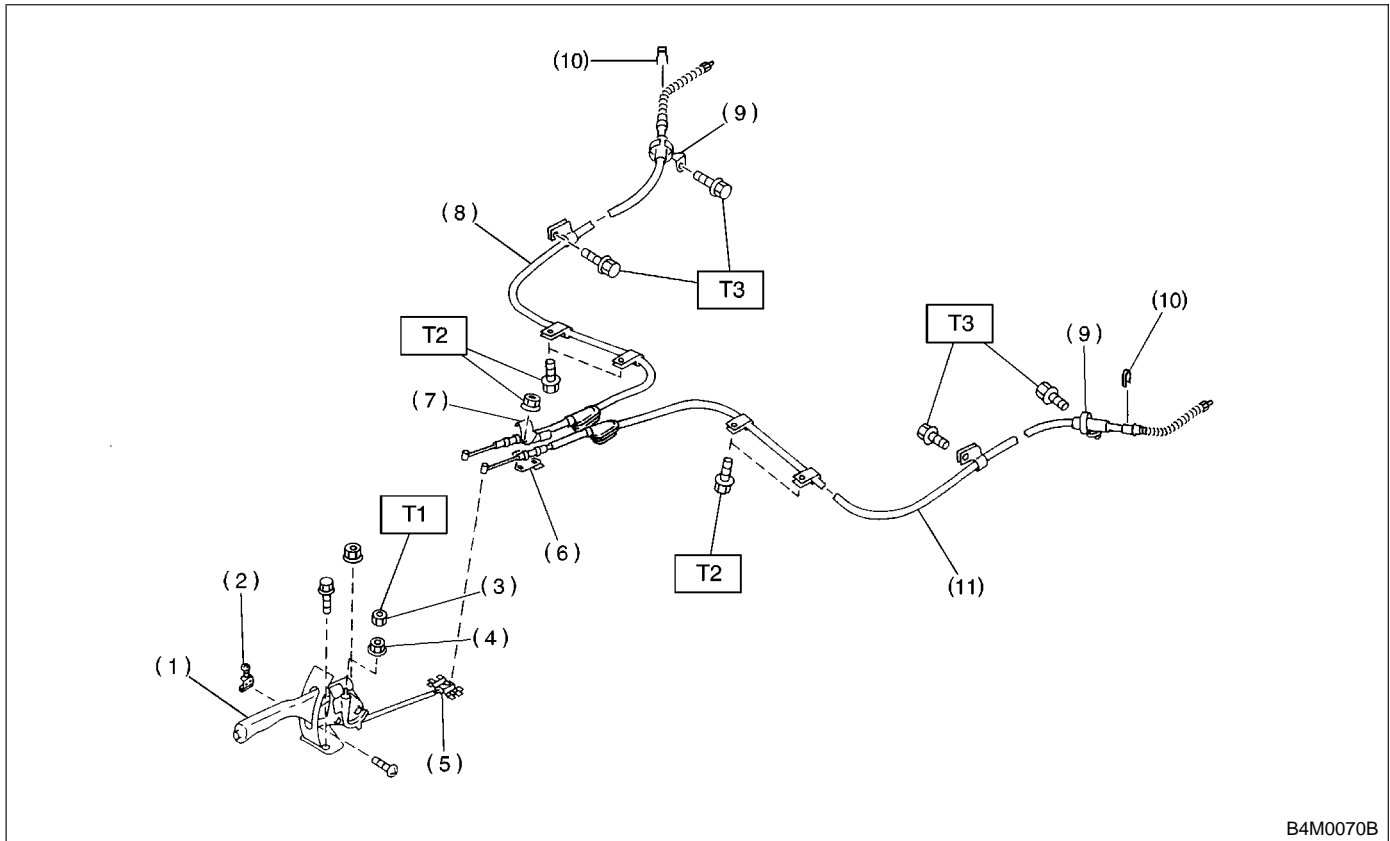

- | | |
|--------------------------|---|
| (1) Parking brake lever | (7) Clamp |
| (2) Parking brake switch | (8) Parking brake cable RH |
| (3) Lock nut | (9) Cable guide |
| (4) Adjusting nut | (10) Clamp (Rear disc brake model only) |
| (5) Equalizer | (11) Parking brake cable LH |
| (6) Bracket | |

Tightening torque: N·m (kgf·m, ft·lb)**T1: 5.9 (0.60, 4.3)****T2: 18 (1.8, 13.0)****T3: 32 (3.3, 24)**

C: CAUTION S404001A03

- Wear working clothing, including a cap, protective goggles, and protective shoes during operation.
- Remove contamination including dirt and corrosion before removal, installation or disassembly.
- Keep the disassembled parts in order and protect them from dust or dirt.
- Before removal, installation or disassembly, be sure to clarify the failure. Avoid unnecessary removal, installation, disassembly, and replacement.
- Be careful not to burn your hands, because each part on the vehicle is hot after running.
- Use SUBARU genuine grease etc. or the equivalent. Do not mix grease etc. with that of another grade or from other manufacturers.
- Be sure to tighten fasteners including bolts and nuts to the specified torque.
- Place shop jacks or safety stands at the specified points.
- Apply grease onto sliding or revolution surfaces before installation.
- Before installing O-rings or snap rings, apply sufficient amount of grease to avoid damage and deformation.
- Before securing a part on a vise, place cushioning material such as wood blocks, aluminum plate, or shop cloth between the part and the vise.
- Keep grease etc. away from parking brake shoes.

PARKING BRAKE LEVER

Parking Brake

2. Parking Brake Lever S404171

A: REMOVAL S404171A18

- 1) To immobilize vehicle, put the select lever in "1st" or "P" position, and lock the tires.
- 2) Disconnect ground terminal connector from battery.
- 3) Remove console cover. <Ref. to EI-30, Console Box.>
- 4) Disconnect connector parking brake switch.
- 5) Loosen parking cable adjusting nut and remove inner cable end from equalizer.
- 6) Remove parking brake lever.

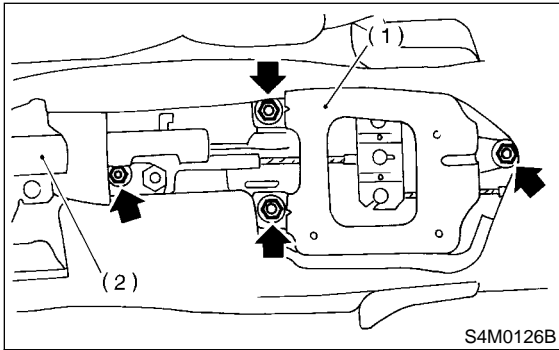

- (1) Console bracket
- (2) Parking brake lever

- 7) Unbend parking brake lever pawls and remove cable.

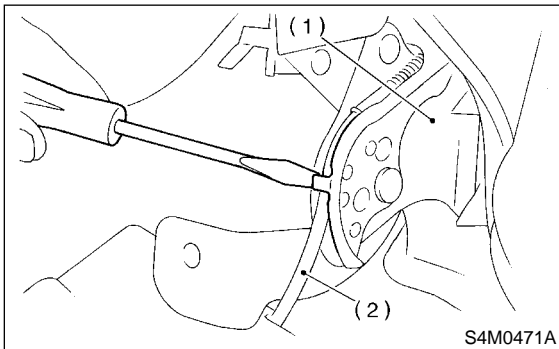

- (1) Parking brake lever
- (2) Cable

B: INSTALLATION S404171A11

Install in the reverse order of removal.

Tightening torque:

Parking brake lever;

18 N·m (1.8 kgf·m, 13.0 ft·lb)

Adjusting nut;

5.9 N·m (0.6 kgf·m, 4.3 ft·lb)

NOTE:

- Be sure to pass cable through guide inside the tunnel.

- Be sure to adjust the lever stroke. <Ref. to PB-6 ADJUSTMENT, Parking Brake Lever.>

C: INSPECTION S404171A10

While pulling parking brake lever upward, count the notches.

Lever stroke:

7 to 8 notches when pulled with a force of 196 N (20 kgf, 44 lb)

Incorrect, adjust the parking brake. <Ref. to PB-11 ADJUSTMENT, Parking Brake Assembly (Rear Disc Brake).>

D: ADJUSTMENT S404171A01

- 1) Remove console cover.
- 2) Forcibly pull parking brake lever 3 to 5 times.
- 3) Adjust parking brake lever by turning adjuster until parking brake lever stroke is set at 7 to 8 notches with operating force of 196 N (20 kgf, 44 lb).
- 4) Tighten lock nut.

Lever stroke:

7 to 8 notches when pulled with a force of 196 N (20 kgf, 44 lb)

Tightening torque (Lock nut):

5.9 N·m (0.60 kgf·m, 4.3 ft·lb)

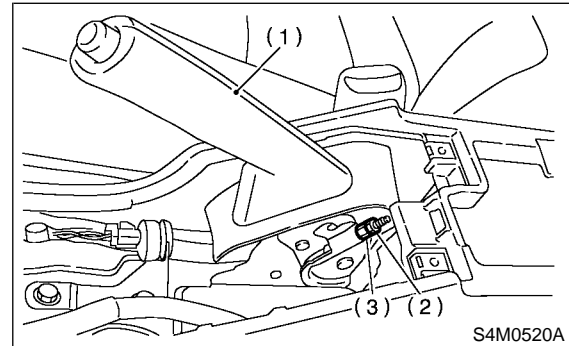

- (1) Parking brake lever
- (2) Lock nut
- (3) Adjusting nut

- 5) Install console cover.

3. Parking Brake Cable S404170

A: REMOVAL S404170A18

- 1) Set vehicle on a lift.
- 2) Disconnect battery ground terminal from battery.
- 3) Lift-up vehicle.
- 4) Remove rear tires and wheels.
- 5) Remove rear cushion.
- 6) Remove console box. <Ref. to EI-30, Console Box.>
- 7) Loosen parking cable adjusting nut and console bracket.
- 8) Remove parking brake lever.

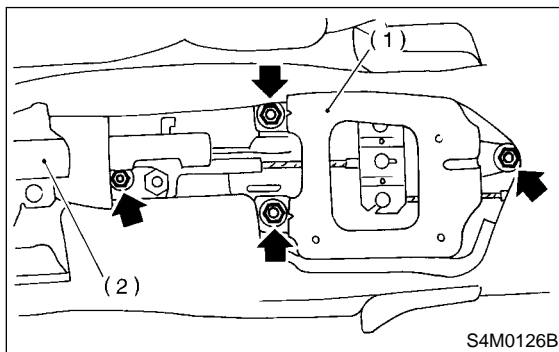

- (1) Console bracket
- (2) Parking brake lever

- 9) Roll up floor mat and remove clamps.

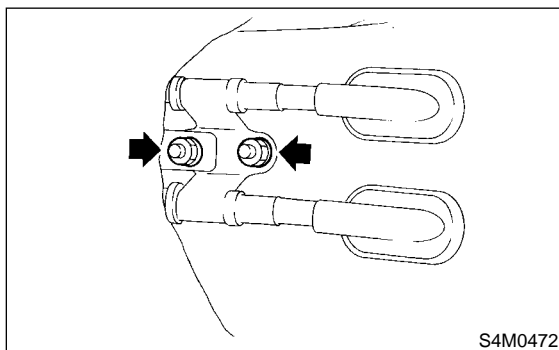

- 10) Remove equalizer cover.

- 11) Remove inner cable end from equalizer.

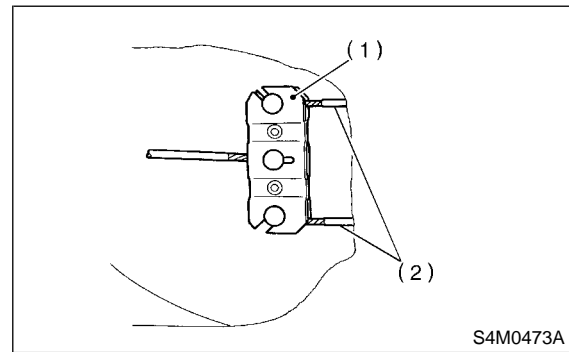

- (1) Equalizer
- (2) Inner cable end

- 12) Pull out parking brake cable from rear brake. Disc brake: <Ref. to PB-9 REMOVAL, Parking Brake Assembly (Rear Disc Brake).>

Drum brake: <Ref. to BR-35, Rear Drum Brake Assembly.>

- 13) Pull out clamp from rear brake.
- 14) Remove bolt and bracket from trailing link bracket.
- 15) Remove bolt and clamp from rear floor.

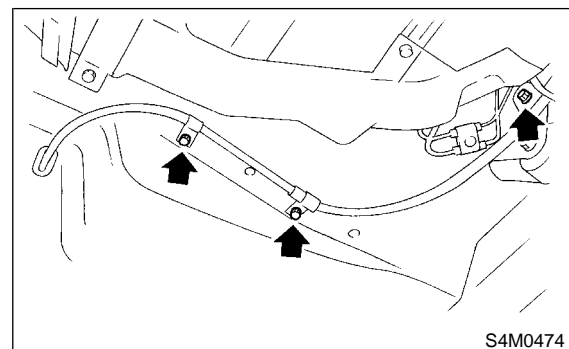

- 16) Detach grommet from rear floor.
- 17) Remove cable assembly from cabin by forcibly pulling it backward.
- 18) Detach parking brake cable from cable guide at rear trailing link.

PARKING BRAKE CABLE

Parking Brake

B: INSTALLATION S404170A11

Install (new) parking brake assembly in the reverse order of removal.

NOTE:

- Be sure to pass cable through cable guide inside the tunnel.
- Be sure to adjust the lever stroke. <Ref. to PB-6 ADJUSTMENT, Parking Brake Lever.>

C: INSPECTION S404170A10

Check the removed cable and replace if damaged, rusty, or malfunctioning.

- 1) Check for smooth operation of the cable.
- 2) Check the inner cable for damage and rust.
- 3) Check the outer cable for damage, bends, and cracks.
- 4) Check the boot for damage, cracks, and deterioration.

4. Parking Brake Assembly (Rear Disc Brake) S404552

A: REMOVAL S404552A18

- 1) Set vehicle on a lift.
- 2) Disconnect battery ground terminal from battery.
- 3) Loosen wheel nuts.
- 4) Lift-up vehicle, and remove wheels.
- 5) Remove the two mounting bolts and remove the disc brake assembly.

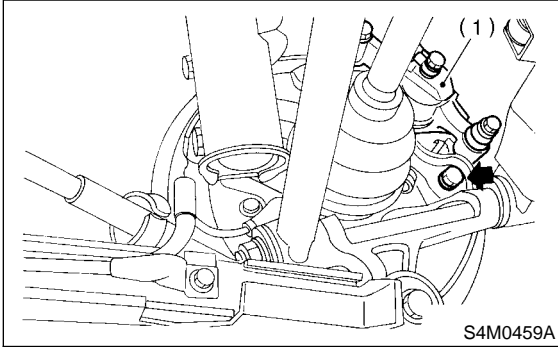

- 6) Suspend the disc brake assembly so that the hose is not stretched.
- 7) Pull down and release parking brake.
- 8) Remove the disc rotor.

NOTE:

If the disc rotor is difficult to remove try the following two methods in order.

- (1) Turn adjusting screw using a slot-type screwdriver until brake shoe gets away enough from the disc rotor.

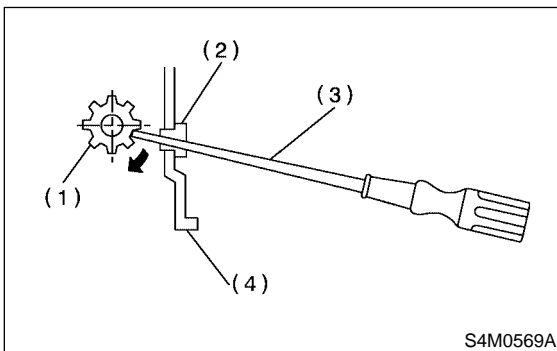

- (1) Adjusting screw
- (2) Adjusting hole cover (rubber)
- (3) Slot-type screwdriver
- (4) Back plate

- (2) If disc rotor seizes up within hub, drive disc rotor out by installing an 8-mm bolt in holes B on the rotor.

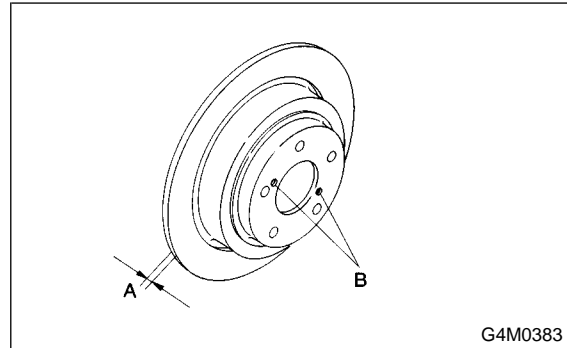

- 9) Remove shoe return spring from parking brake assembly.
- 10) Remove front shoe hold down spring and pin with pliers.

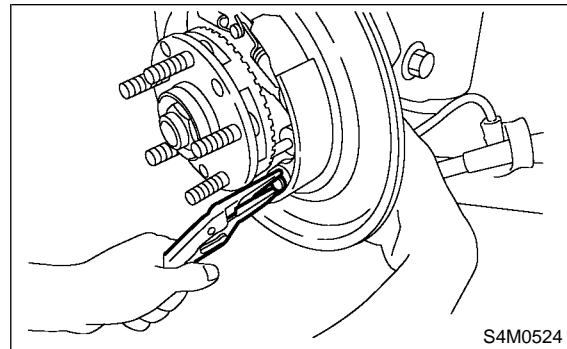

- 11) Remove strut and strut spring.
- 12) Remove adjuster assembly from parking brake assembly.
- 13) Remove brake shoe.
- 14) Remove rear shoe hold-down spring and pin with pliers.
- 15) Remove parking cable from parking lever.

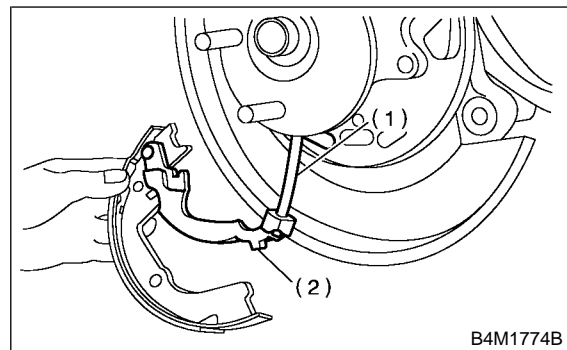

- (1) Parking brake cable
- (2) Parking brake lever

- 16) Using a standard screwdriver, raise retainer. Remove parking lever and washer from brake shoe.

PARKING BRAKE ASSEMBLY (REAR DISC BRAKE)

Parking Brake

B: INSTALLATION S404552A11

CAUTION:

Be sure lining surface is free from oil contamination.

Brake grease:

Dow Corning Molykote No. 7439 (Part No. 725191460)

1) Apply brake grease to the following places.

- Six contact surfaces of shoe rim and back plate packing
- Contact surface of shoe wave and anchor pin
- Contact surface of lever and strut
- Contact surface of shoe wave and adjuster assembly
- Contact surface of shoe wave and strut
- Contact surface of lever and shoe wave

2) Install in reverse order of removal.

CAUTION:

- Use new retainers and clinch them when installing brake shoes to levers.
- Ensure that parking lever moves smoothly.
- Do not confuse left parking lever with right one.
- Do not confuse left strut with right one.

NOTE:

Ensure that adjuster assembly is securely installed with screw in the left side, facing vehicle front.

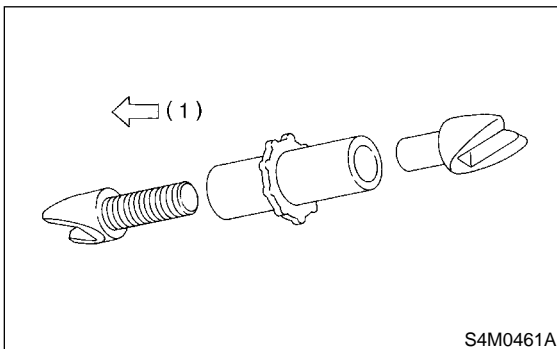

S4M0461A

(1) LEFT

NOTE:

Ensure that shoe return spring is installed as shown in Figure.

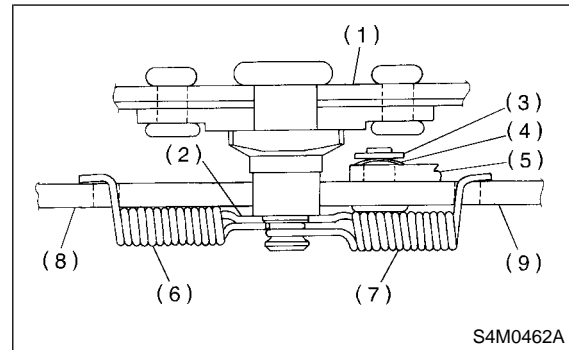

S4M0462A

- (1) Back plate
- (2) Shoe guide plate
- (3) Retainer
- (4) Spring washer
- (5) Lever
- (6) Primary shoe return spring (Blue)
- (7) Secondary shoe return spring (Yellow)
- (8) Parking brake shoe (Primary)
- (9) Parking brake shoe (Secondary)

3) Adjust parking brakes. <Ref. to PB-11 ADJUSTMENT, Parking Brake Assembly (Rear Disc Brake).>

CAUTION:

After replacing parking brake lining, be sure to drive vehicle for "break-in" purposes.

- (1) Drive the vehicle about 35 km/h (22 MPH).
- (2) With the parking brake release button pushed in, pull the parking brake lever gently.
- (3) Drive the vehicle for about 200 meter (0.12 mile) in this condition.
- (4) Wait 5 to 10 minutes for the parking brake to cool down. Repeat this procedure once more.
- (5) After breaking-in, re-adjust parking brakes.

C: INSPECTION S404552A10

1) Measure brake disc inside diameter. If the disc is scored or worn, replace the brake disc.

Disc inside diameter:

Standard

170 mm (6.69 in)

Service limit

171 mm (6.73 in)

2) Measure the lining thickness. If it exceeds the limit, replace shoe assembly.

Lining thickness:

Standard

3.2 mm (0.126 in)

Service limit

1.5 mm (0.059 in)

CAUTION:

Replace the brake shoes on the right and left brake assembly at the same time.

D: ADJUSTMENT S404552A01

1. SHOE CLEARANCE S404552A0101

- 1) Remove adjusting hole cover from back plate.
- 2) Turn adjusting screw using a slot-type screwdriver until brake shoe is in close contact with disc rotor.

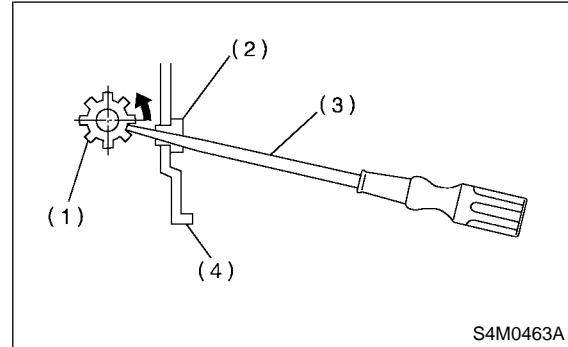

- (1) Adjusting screw
- (2) Adjusting hole cover (rubber)
- (3) Slot-type screwdriver
- (4) Back plate

3) Turn back (downward) adjusting screw 3 or 4 notches.

4) Install adjusting hole cover to back plate.

2. LEVER STROKE S404552A0102

- 1) Remove console box lid.
- 2) Forcibly pull parking brake lever 3 to 5 times.
- 3) Adjust parking brake lever by turning adjuster until parking brake lever stroke is set at 6 notches with operating force of 196 N (20 kgf, 44 lb).

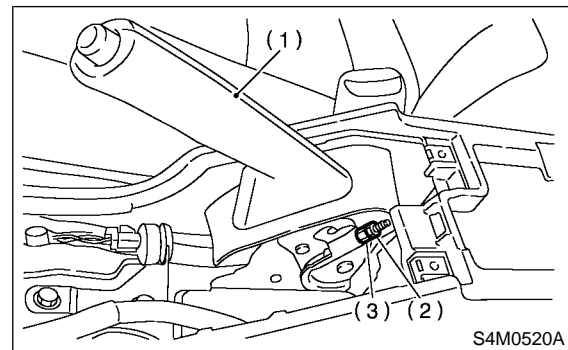

- (1) Parking brake lever
- (2) Lock nut
- (3) Adjusting nut

4) Tighten lock nut.

5) Install console box lid.

Lever stroke:

7 to 8 notches when pulled with a force of 196 N (20 kgf, 44 lb)

Tightening torque (Adjuster lock nut):

5.9 N-m (0.60 kgf-m, 4.3 ft-lb)

GENERAL DIAGNOSTIC TABLE

Parking Brake

5. General Diagnostic Table S404257

A: INSPECTION S404257A10

Symptom	Possible cause	Remedy
Brake drag	● Parking brake lever is maladjusted.	● Adjustment.
	● Parking brake cable does not move.	● Repair or replace.
	● Parking brake shoe clearance is maladjusted.	● Adjustment.
	● Return spring is faulty.	● Replace.
Noise from brake	● Return spring is faulty.	● Replace.
	● Shoe hold down spring is faulty.	● Replace.