

# ENGINE (DIAGNOSTICS)

# *EN(SOHC)*

---

	<b>Page</b>
1. Basic Diagnostic Procedure .....	2
2. Check List for Interview.....	4
3. General Description.....	6
4. Electrical Components Location.....	10
5. Engine Control Module (ECM) I/O Signal.....	24
6. Engine Condition Data .....	27
7. Transmission Control Module (TCM) I/O Signal.....	28
8. Data Link Connector .....	31
9. OBD-II General Scan Tool .....	32
10. Subaru Select Monitor.....	34
11. Read Diagnostic Trouble Code .....	41
12. Inspection Mode.....	42
13. Clear Memory Mode.....	45
14. Compulsory Valve Operation Check Mode.....	46
15. Engine Malfunction Indicator Lamp (MIL).....	48
16. Diagnostics for Engine Starting Failure .....	59
17. List of Diagnostic Trouble Code (DTC).....	80
18. Diagnostic Procedure with Diagnostic Trouble Code (DTC) .....	86
19. General Diagnostic Table .....	294

# BASIC DIAGNOSTIC PROCEDURE

Engine (Diagnostics)

## 1. Basic Diagnostic Procedure

S058501

### A: PROCEDURE S058501E45

#### 1. ENGINE S058501E4501

No.	Step	Check	Yes	No
1	<b>CHECK ENGINE START FAILURE.</b> 1) Ask the customer when and how the trouble occurred using the interview check list. <Ref. to EN(SOHC)-4, CHECK, Check List for Interview.> 2) Start the engine.	Does the engine start?	Go to step 2.	Inspection using "Diagnostics for Engine Start Failure". <Ref. to EN(SOHC)-59, Diagnostics for Engine Starting Failure.>
2	<b>CHECK ILLUMINATION OF CHECK ENGINE MALFUNCTION INDICATOR LAMP (MIL).</b>	Does CHECK ENGINE malfunction indicator lamp illuminate?	Go to step 3.	Inspection using "General Diagnostics Table". <Ref. to EN(SOHC)-294, INSPECTION, General Diagnostic Table.>
3	<b>CHECK INDICATION OF DTC ON DISPLAY.</b> 1) Turn ignition switch to OFF. 2) Connect the Subaru Select Monitor or the OBD-II general scan tool to data link connector. 3) Turn ignition switch to ON and the Subaru Select Monitor or OBD-II general scan tool switch to ON. 4) Read DTC on the Subaru Select Monitor or OBD-II general scan tool.	Does the Subaru Select Monitor or OBD-II general scan tool indicate DTC?	Record diagnostic trouble code. Repair the trouble cause. <Ref. to EN(SOHC)-80, OPERATION, List of Diagnostic Trouble Code (DTC).> Go to step 4.	Repair the related parts. NOTE: If DTC is not shown on display although the MIL illuminates, perform diagnostics of MIL (CHECK ENGINE malfunction indicator lamp) circuit or combination meter. <Ref. to EN(SOHC)-48, Engine Malfunction Indicator Lamp (MIL).>
4	<b>PERFORM THE DIAGNOSIS.</b> 1) Perform the clear memory mode. <Ref. to EN(SOHC)-45, Clear Memory Mode.> 2) Perform the inspection mode. <Ref. to EN(SOHC)-42, Inspection Mode.>	Does the Subaru Select Monitor or OBD-II general scan tool indicate DTC?	Inspect using "Diagnostics Procedure with Diagnostic Trouble Code (DTC)". <Ref. to EN(SOHC)-86, Diagnostic Procedure with Diagnostic Trouble Code (DTC).>	Complete the diagnosis.

## 2. AUTOMATIC TRANSMISSION S058501E4502

When trouble code about automatic transmission is shown on display, carry out the following basic check. After that, carry out the replacement or repair work.

- 1) ATF level check <Ref. to AT-9, Automatic Transmission Fluid.>
- 2) Differential gear oil level check <Ref. to AT-11, Differential Gear Oil.>
- 3) ATF leak check <Ref. to AT-9, Automatic Transmission Fluid.>
- 4) Differential gear oil leak check <Ref. to AT-11, Differential Gear Oil.>
- 5) Stall test <Ref. to AT-13, Stall Test.>
- 6) Line pressure test <Ref. to AT-16, Line Pressure Test.>
- 7) Transfer clutch pressure test <Ref. to AT-18, Transfer Clutch Pressure Test.>
- 8) Time lag test <Ref. to AT-15, Time Lag Test.>
- 9) Road test <Ref. to AT-12, Road Test.>
- 10) Shift characteristics <Ref. to AT-18, Transfer Clutch Pressure Test.>

# CHECK LIST FOR INTERVIEW

Engine (Diagnostics)

## 2. Check List for Interview S058502

Check the following items when problem has occurred.

### A: CHECK S058502A04

NOTE:

#### 1. CHECK LIST NO. 1 S058502A0401

Use copies of this page for interviewing customers.

Customer's name		Engine no.	
Date of sale		Fuel brand	
Date of repair		Odometer reading	km
Vin no.			miles
Weather	<input type="checkbox"/> Fine <input type="checkbox"/> Cloudy <input type="checkbox"/> Rainy <input type="checkbox"/> Snowy <input type="checkbox"/> Various/Others:		
Outdoor temperature	°C (°F)		
	<input type="checkbox"/> Hot <input type="checkbox"/> Warm <input type="checkbox"/> Cool <input type="checkbox"/> Cold		
Place	<input type="checkbox"/> Highway <input type="checkbox"/> Suburbs <input type="checkbox"/> Inner city <input type="checkbox"/> Uphill <input type="checkbox"/> Downhill <input type="checkbox"/> Rough road <input type="checkbox"/> Others:		
Engine temperature	<input type="checkbox"/> Cold <input type="checkbox"/> Warming-up <input type="checkbox"/> After warming-up <input type="checkbox"/> Any temperature <input type="checkbox"/> Others:		
Engine speed	rpm		
Vehicle speed	MPH		
Driving conditions	<input type="checkbox"/> Not affected <input type="checkbox"/> At starting <input type="checkbox"/> While idling <input type="checkbox"/> At racing <input type="checkbox"/> While accelerating <input type="checkbox"/> While cruising <input type="checkbox"/> While decelerating <input type="checkbox"/> While turning (RH/LH)		
Headlight	<input type="checkbox"/> ON/ <input type="checkbox"/> OFF	Rear defogger	<input type="checkbox"/> ON/ <input type="checkbox"/> OFF
Blower	<input type="checkbox"/> ON/ <input type="checkbox"/> OFF	Radio	<input type="checkbox"/> ON/ <input type="checkbox"/> OFF
A/C compressor	<input type="checkbox"/> ON/ <input type="checkbox"/> OFF	CD/Cassette	<input type="checkbox"/> ON/ <input type="checkbox"/> OFF
Cooling fan	<input type="checkbox"/> ON/ <input type="checkbox"/> OFF	Car phone	<input type="checkbox"/> ON/ <input type="checkbox"/> OFF
Front wiper	<input type="checkbox"/> ON/ <input type="checkbox"/> OFF	CB	<input type="checkbox"/> ON/ <input type="checkbox"/> OFF
Rear wiper	<input type="checkbox"/> ON/ <input type="checkbox"/> OFF		

# CHECK LIST FOR INTERVIEW

Engine (Diagnostics)

## 2. CHECK LIST NO. 2 S058502A0402

NOTE:

Use copies of this page for interviewing customers.

Check the following items about the vehicle's state when MIL turns on.

a) Other warning lights or indicators turn on. <input type="checkbox"/> Yes/ <input type="checkbox"/> No
<input type="checkbox"/> Low fuel warning light
<input type="checkbox"/> Charge indicator light
<input type="checkbox"/> AT diagnostics indicator light
<input type="checkbox"/> ABS warning light
<input type="checkbox"/> VDC warning light
<input type="checkbox"/> Engine oil pressure warning light
b) Fuel level
● Lack of gasoline: <input type="checkbox"/> Yes/ <input type="checkbox"/> No
● Indicator position of fuel gauge:
c) Intentional connecting or disconnecting of harness connectors or spark plug cords: <input type="checkbox"/> Yes/ <input type="checkbox"/> No
● What:
d) Intentional connecting or disconnecting of hoses: <input type="checkbox"/> Yes/ <input type="checkbox"/> No
● What:
e) Installing of parts other than genuine parts: <input type="checkbox"/> Yes/ <input type="checkbox"/> No
● What:
● Where:
f) Occurrence of noise: <input type="checkbox"/> Yes/ <input type="checkbox"/> No
● From where:
● What kind:
g) Occurrence of smell: <input type="checkbox"/> Yes/ <input type="checkbox"/> No
● From where:
● What kind:
h) Intrusion of water into engine compartment or passenger compartment: <input type="checkbox"/> Yes/ <input type="checkbox"/> No
i) Troubles occurred
<input type="checkbox"/> Engine does not start.
<input type="checkbox"/> Engine stalls during idling.
<input type="checkbox"/> Engine stalls while driving.
<input type="checkbox"/> Engine speed decreases.
<input type="checkbox"/> Engine speed does not decrease.
<input type="checkbox"/> Rough idling
<input type="checkbox"/> Poor acceleration
<input type="checkbox"/> Back fire
<input type="checkbox"/> After fire
<input type="checkbox"/> No shift
<input type="checkbox"/> Excessive shift shock

# GENERAL DESCRIPTION

Engine (Diagnostics)

## 3. General Description S058001

### A: CAUTION S058001A03

1) Airbag system wiring harness is routed near the engine control module (ECM), main relay and fuel pump relay.

#### CAUTION:

- All Airbag system wiring harness and connectors are colored yellow. Do not use electrical test equipment on these circuit.

- Be careful not to damage Airbag system wiring harness when servicing the engine control module (ECM), transmission control module (TCM), main relay and fuel pump relay.

2) Never connect the battery in reverse polarity.

- The ECM will be destroyed instantly.
- The fuel injector and other part will be damaged in just a few minutes more.

3) Do not disconnect the battery terminals while the engine is running.

- A large counter electromotive force will be generated in the alternator, and this voltage may damage electronic parts such as ECM, etc.

4) Before disconnecting the connectors of each sensor and the ECM, be sure to turn OFF the ignition switch.

5) Poor contact has been identified as a primary cause of this problem. To measure the voltage and/or resistance of individual sensors or all electrical control modules at the harness side connector, use a tapered pin with a diameter of less than 0.64 mm (0.025 in). Do not insert the pin more than 5 mm (0.20 in) into the part.

6) Before removing ECM from the located position, disconnect two cables on battery.

- Otherwise, the ECM may be damaged.

#### CAUTION:

**When replacing ECM, be careful not to use the wrong spec. ECM to avoid any damage on fuel injection system.**

7) The connectors to each sensor in the engine compartment and the harness connectors on the engine side and body side are all designed to be waterproof. However, it is still necessary to take care not to allow water to get into the connectors when washing the vehicle, or when servicing the vehicle on a rainy day.

8) Use ECM mounting stud bolts at the body head grounding point when measuring voltage and resistance inside the passenger compartment.

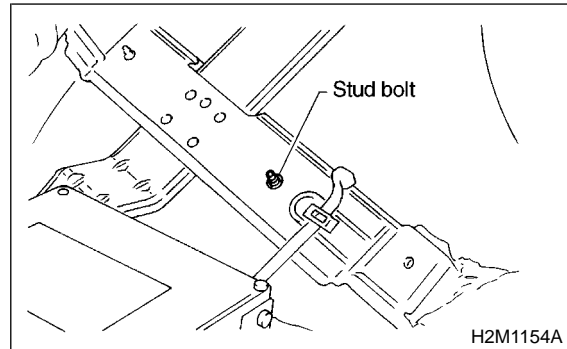

9) Use engine grounding terminal or engine proper as the grounding point to the body when measuring voltage and resistance in the engine compartment.

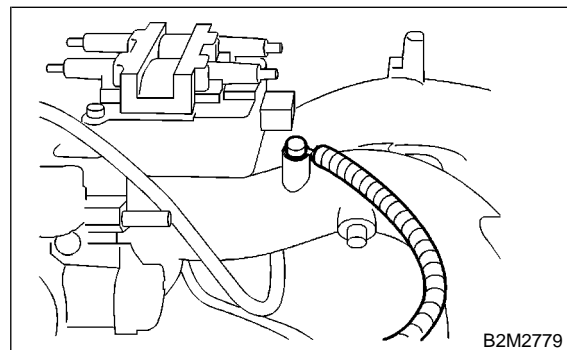

10) Use TCM mounting stud bolts at the body head grounding point when measuring voltage and resistance inside the passenger compartment.

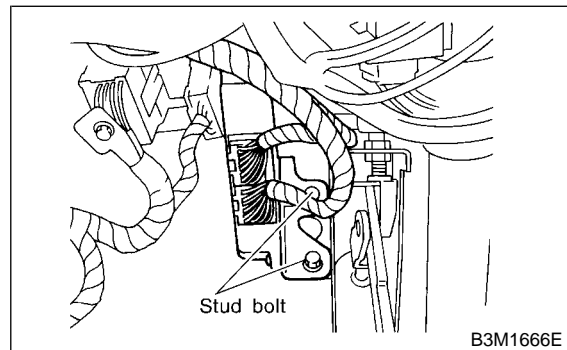

11) Every MFI-related part is a precision part. Do not drop them.

12) Observe the following cautions when installing a radio in MFI equipped models.

#### CAUTION:

- The antenna must be kept as far apart as possible from the control unit.

(The ECM is located under the steering column, inside of the instrument panel lower trim panel.)

- The antenna feeder must be placed as far apart as possible from the ECM and MFI harness.
- Carefully adjust the antenna for correct matching.
- When mounting a large power type radio, pay special attention to the three items above mentioned.
- Incorrect installation of the radio may affect the operation of the ECM.

13) Before disconnecting the fuel hose, disconnect the fuel pump connector and crank the engine for more than five seconds to release pressure in the fuel system. If engine starts during this operation, run it until it stops.

14) Problems in the electronic-controlled automatic transmission may be caused by failure of the engine, the electronic control system, the transmission proper, or by a combination of these. These three causes must be distinguished clearly when performing diagnostics.

15) Diagnostics should be conducted by rotating with simple, easy operations and proceeding to complicated, difficult operations. The most important thing in diagnostics is to understand the customer's complaint, and distinguish between the three causes.

16) In AT vehicles, do not continue the stall for more than five seconds at a time (from closed throttle, fully open throttle to stall engine speed).

17) On ABS vehicle, when performing driving test in jacked-up or lifted-up position, sometimes the warning light may be lit, but this is not a malfunction of the system. The reason for this is the speed difference between the front and rear wheels. After diagnosis of engine control system, perform the ABS memory clearance procedure of self-diagnosis system.

## B: INSPECTION S058001A10

Before performing diagnostics, check the following items which might affect engine problems:

### 1. BATTERY S058001A1001

1) Measure battery voltage and specific gravity of electrolyte.

**Standard voltage: 12 V**

**Specific gravity: Above 1.260**

2) Check the condition of the main and other fuses, and harnesses and connectors. Also check for proper grounding.

## 2. ENGINE GROUNDING S058001A1002

Make sure the engine grounding terminal is properly connected to the engine.

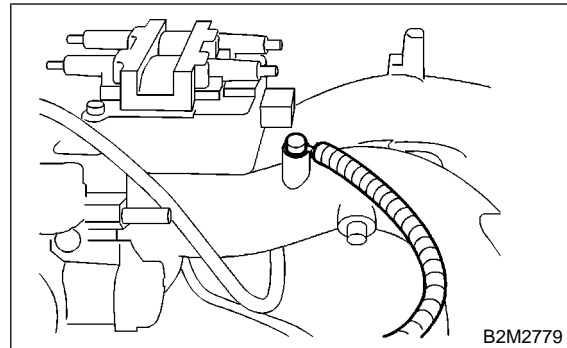

## C: NOTE S058001A15

### 1. DESCRIPTION S058001A1501

● The on-board diagnostics (OBD) system detects and indicates a fault in various inputs and outputs of the complex electronic control. CHECK ENGINE malfunction indicator lamp (MIL) in the combination meter indicates occurrence of a fault or trouble.

● Further, against such a failure or sensors as may disable the drive, the fail-safe function is provided to ensure the minimal driveability.

● The OBD system incorporated with the vehicles within this engine family complies with Section 1968.1, California Code of Regulations (OBD-II regulation). The OBD system monitors the components and the system malfunction listed in Engine Section which affects on emissions.

● When the system decides that a malfunction occurs, MIL illuminates. At the same time of the MIL illumination or blinking, a diagnostic trouble code (DTC) and a freeze frame engine conditions are stored into on-board computer.

● The OBD system stores freeze frame engine condition data (engine load, engine coolant temperature, fuel trim, engine speed and vehicle speed, etc.) into on-board computer when it detects a malfunction first.

● If the OBD system detects the various malfunctions including the fault of fuel trim or misfire, the OBD system first stores freeze frame engine conditions about the fuel trim or misfire.

● When the malfunction does not occur again for three consecutive driving cycles, MIL is turned off, but DTC remains at on-board computer.

● The OBD-II system is capable of communication with a general scan tool (OBD-II general scan tool) formed by ISO 9141 CARB.

● The OBD-II diagnostics procedure is different from the usual diagnostics procedure. When troubleshooting OBD-II vehicles, connect Subaru

# GENERAL DESCRIPTION

Engine (Diagnostics)

Select Monitor or the OBD-II general scan tool to the vehicle.

## 2. ENGINE AND EMISSION CONTROL SYSTEM

S058001A1502

● The Multipoint Fuel Injection (MFI) system is a system that supplies the optimum air-fuel mixture to the engine for all the various operating conditions through the use of the latest electronic technology.

With this system fuel, which is pressurized at a constant pressure, is injected into the intake air passage of the cylinder head. The injection quantity of fuel is controlled by an intermittent injection system where the electro-magnetic injection valve (fuel injector) opens only for a short period of time, depending on the quantity of air required for one cycle of operation. In actual operation, the injection quantity is determined by the duration of an electric pulse applied to the fuel injector and this permits simple, yet highly precise metering of the fuel.

● Further, all the operating conditions of the engine are converted into electric signals, and this results in additional features of the system, such as large improved adaptability, easier addition of compensating element, etc.

The MFI system also has the following features:

- Reduced emission of harmful exhaust gases.
- Reduced in fuel consumption.
- Increased engine output.
- Superior acceleration and deceleration.
- Superior startability and warm-up performance in cold weather since compensation is made for coolant and intake air temperature.



## 3. AUTOMATIC TRANSMISSION AND ELECTRONIC-HYDRAULIC CONTROL SYSTEM

S058001A1503

The electronic-hydraulic control system consists of various sensors and switches, a transmission control module (TCM) and the hydraulic controller including solenoid valves. The system controls the transmission proper including shift control, lock-up control, overrunning clutch control, line pressure control and shift timing control. It also controls the AWD transfer clutch. In other words, the system detects various operating conditions from various input signals and sends output signals to shift solenoids 1, 2 and low clutch timing solenoid and 2-4 brake timing solenoid, line pressure duty solenoid, lock-up duty solenoid, transfer duty solenoid and 2-4 brake duty solenoid (a total of eight solenoids).

## D: PREPARATION TOOL

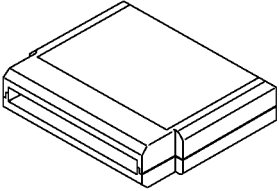
S058001A17

ILLUSTRATION	TOOL NUMBER	DESCRIPTION	REMARKS
 <p>B2M3876</p>	24082AA150 (Newly adopted tool)	CARTRIDGE	Troubleshooting for electrical systems.
 <p>B2M3877</p>	22771AA030	SELECT MONITOR KIT	Troubleshooting for electrical systems. <ul style="list-style-type: none"> <li>● English: 22771AA030 (Without printer)</li> <li>● German: 22771AA070 (Without printer)</li> <li>● French: 22771AA080 (Without printer)</li> <li>● Spanish: 22771AA090 (Without printer)</li> </ul>



**MEMO:**

# ELECTRICAL COMPONENTS LOCATION

Engine (Diagnostics)

## 4. Electrical Components Location

S058507

### A: LOCATION

S058507A13

#### 1. ENGINE

S058507A1301

#### ● MODULE

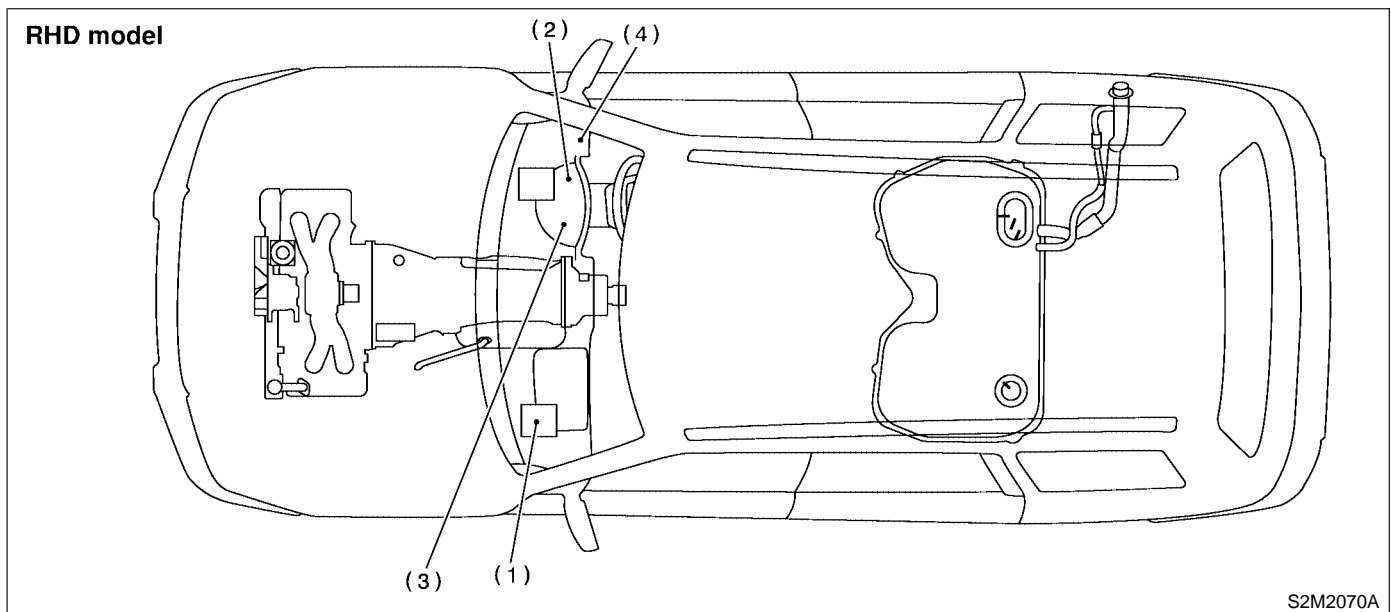
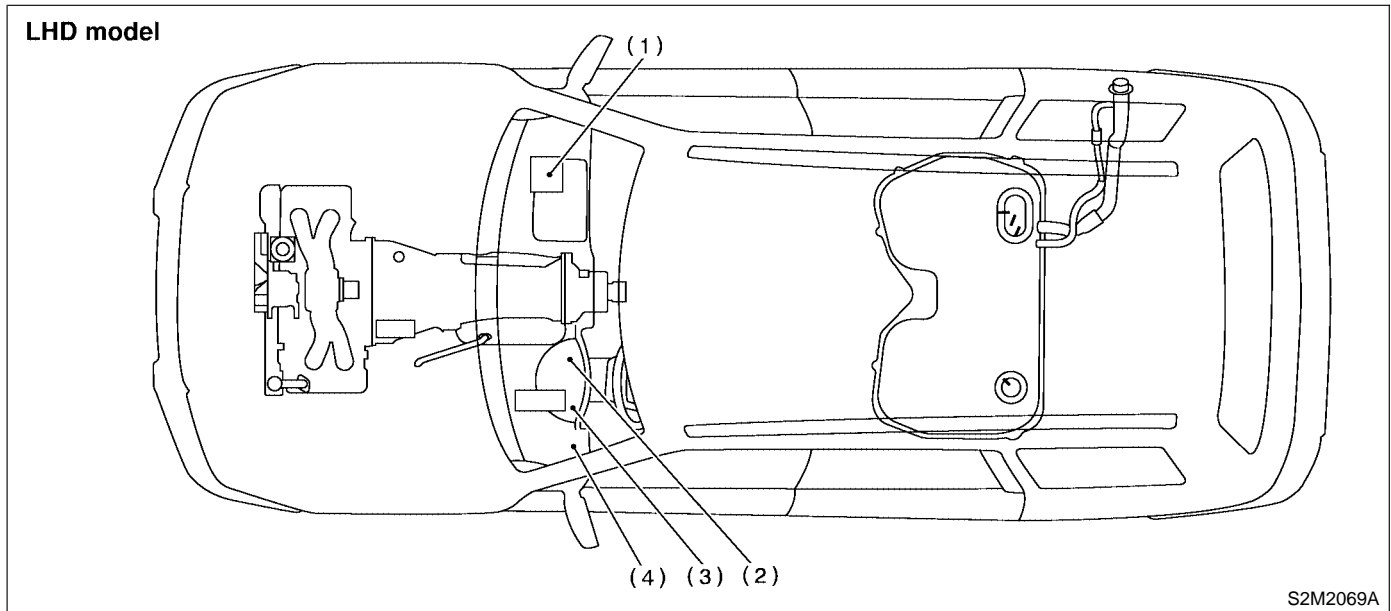

(1) Engine control module (ECM)  
(2) CHECK ENGINE malfunction indicator lamp (MIL)

(3) Test mode connector

(4) Data link connector (for Subaru Select Monitor and OBD-II general scan tool)

# ELECTRICAL COMPONENTS LOCATION

Engine (Diagnostics)

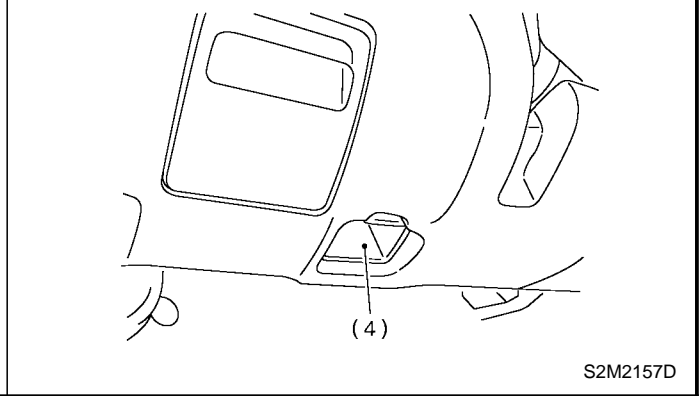
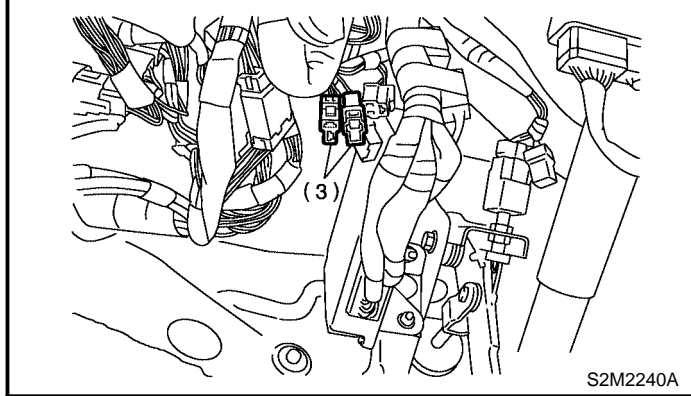
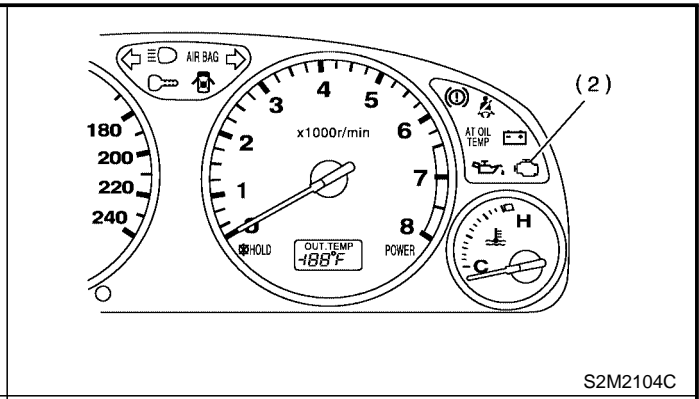
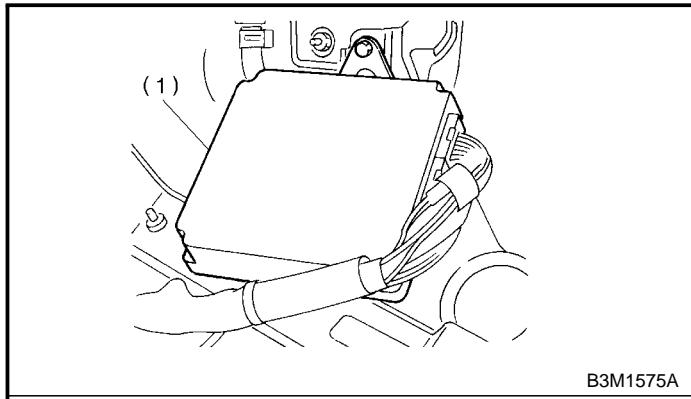

# ELECTRICAL COMPONENTS LOCATION

Engine (Diagnostics)

## ● SENSOR

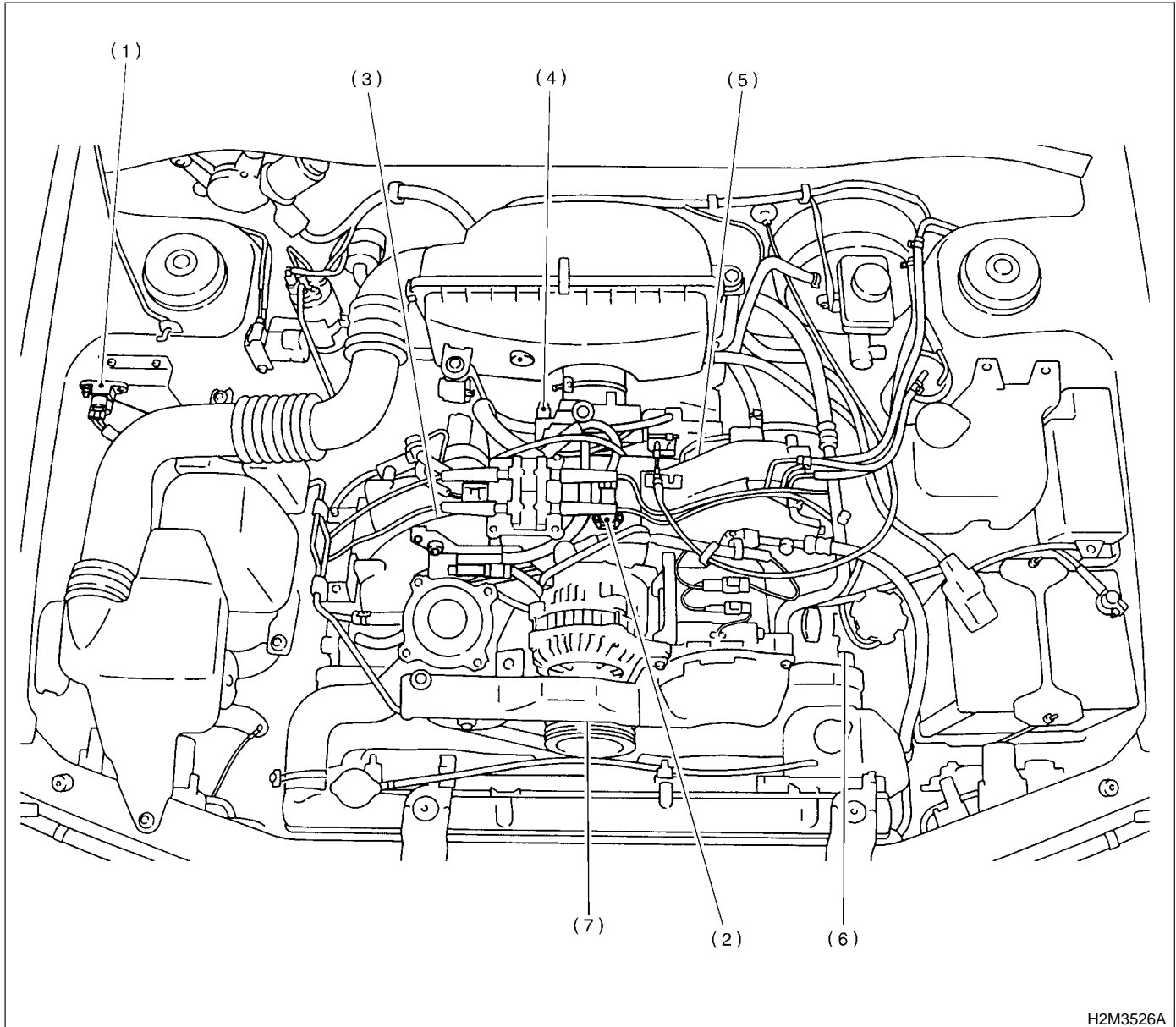

- |  |                                       |                              |
|--|---------------------------------------|------------------------------|
| (1) Atmospheric pressure sensor                | (3) Engine coolant temperature sensor | (5) Knock sensor             |
| (2) Intake air temperature and pressure sensor | (4) Throttle position sensor          | (6) Camshaft position sensor |
|  | (7) Crankshaft position sensor        |                              |

# ELECTRICAL COMPONENTS LOCATION

Engine (Diagnostics)

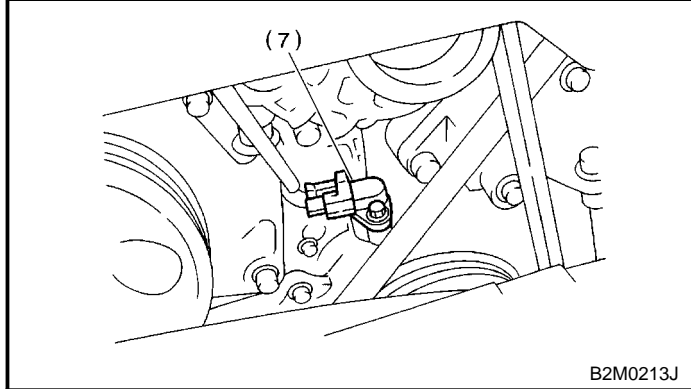
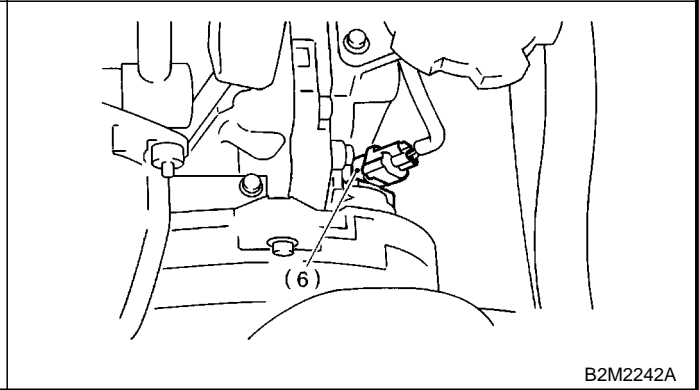
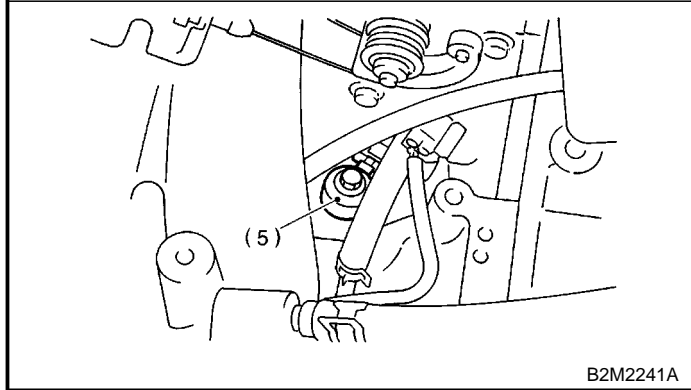
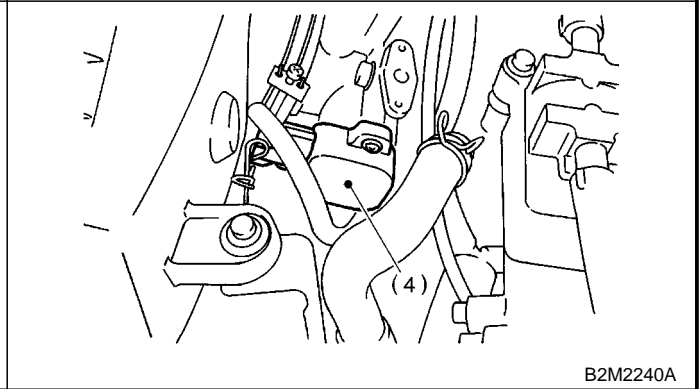
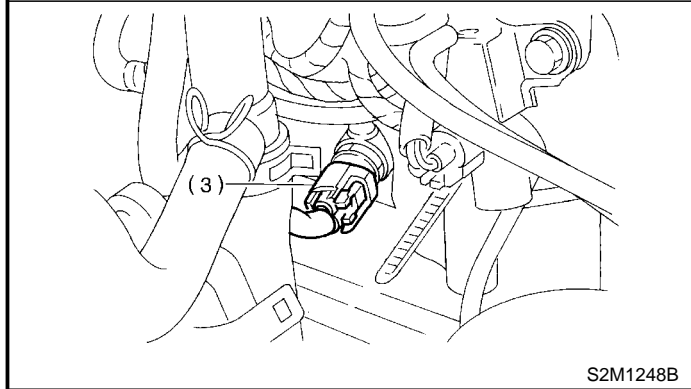
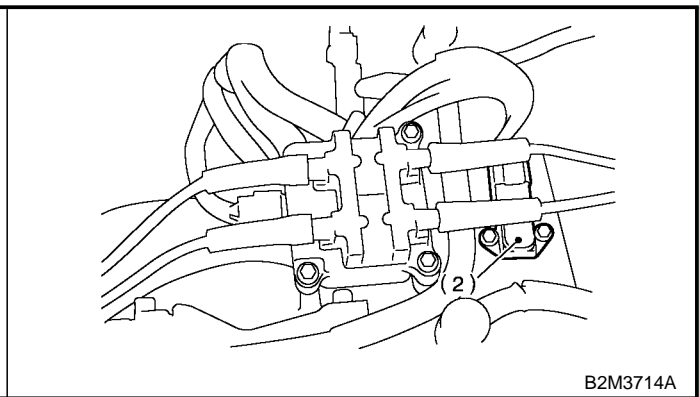
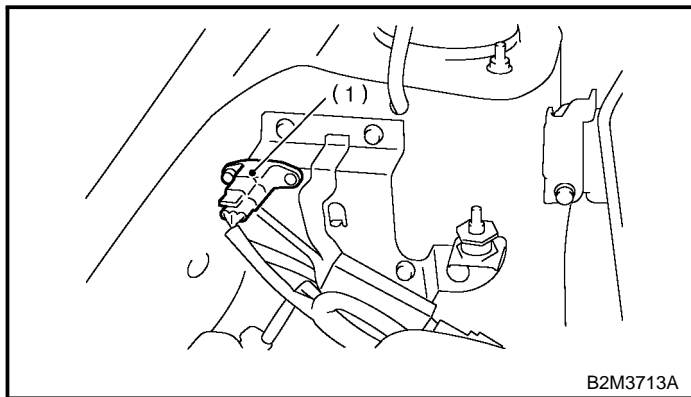

# ELECTRICAL COMPONENTS LOCATION

Engine (Diagnostics)

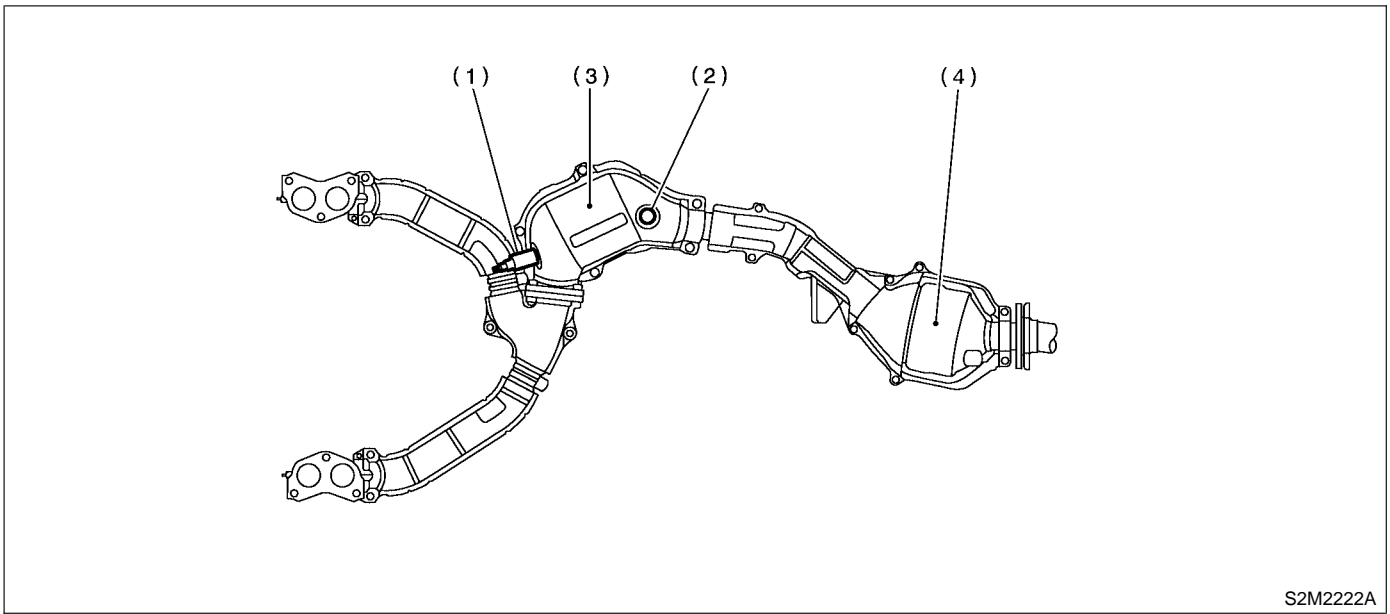

S2M2222A

- (1) Front oxygen (A/F) sensor
- (2) Rear oxygen sensor

- (3) Front catalytic converter
- (4) Rear catalytic converter

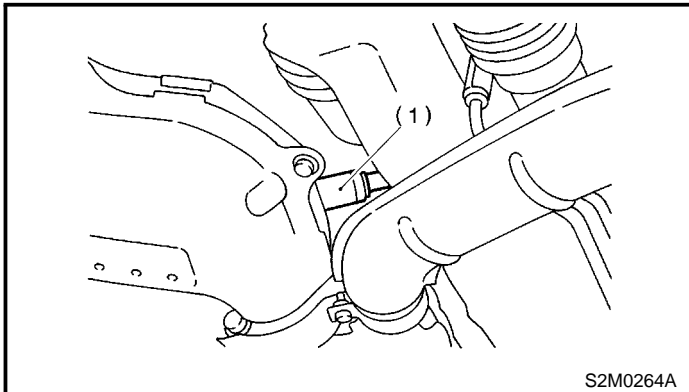

S2M0264A

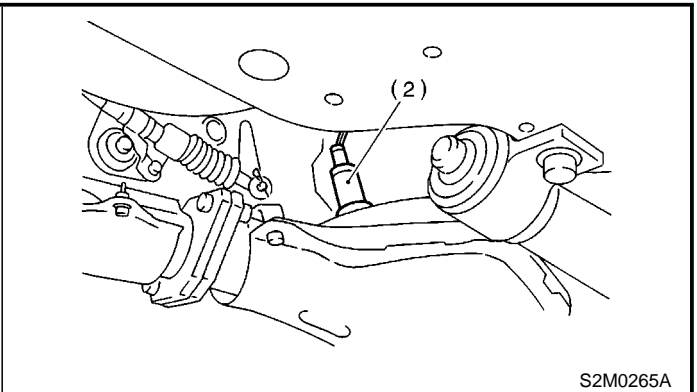

S2M0265A

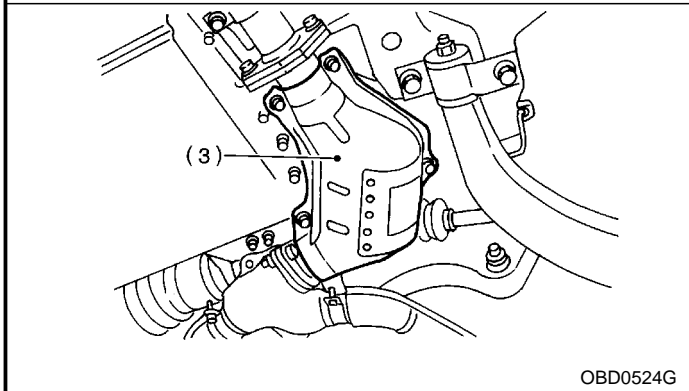

OBD0524G

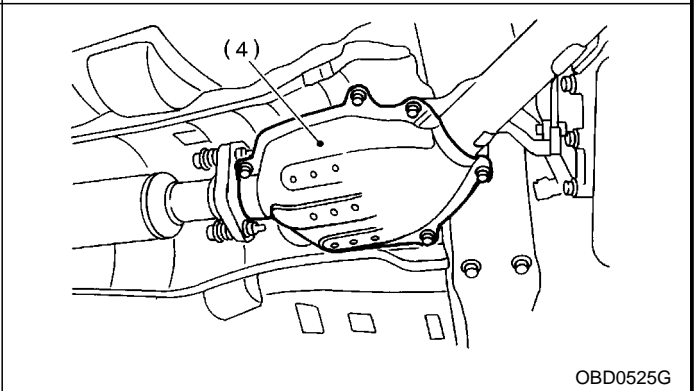

OBD0525G

# ELECTRICAL COMPONENTS LOCATION

Engine (Diagnostics)

LHD model

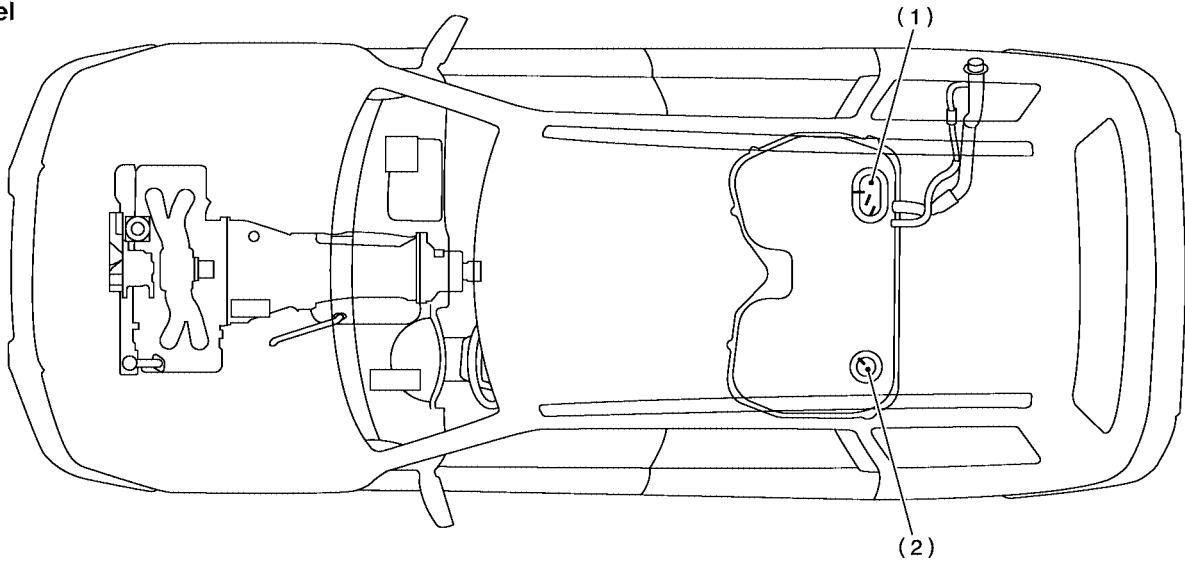

S2M2069B

RHD model

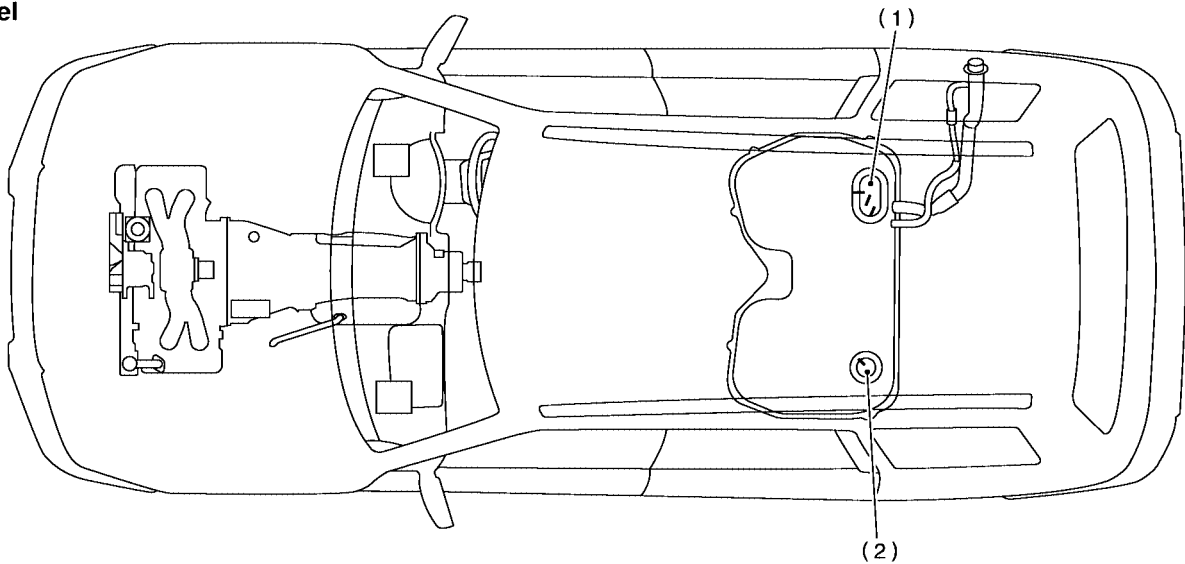

S2M2070B

(1) Fuel level sensor

(2) Fuel sub level sensor

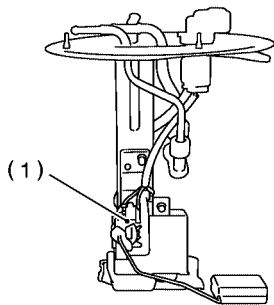

S2M2080A

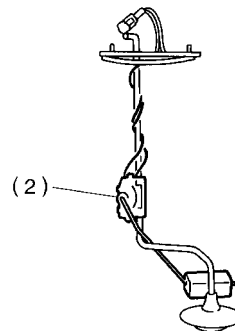

S2M0270B

# ELECTRICAL COMPONENTS LOCATION

Engine (Diagnostics)

## ● SOLENOID VALVE, EMISSION CONTROL SYSTEM PARTS AND IGNITION SYSTEM PARTS

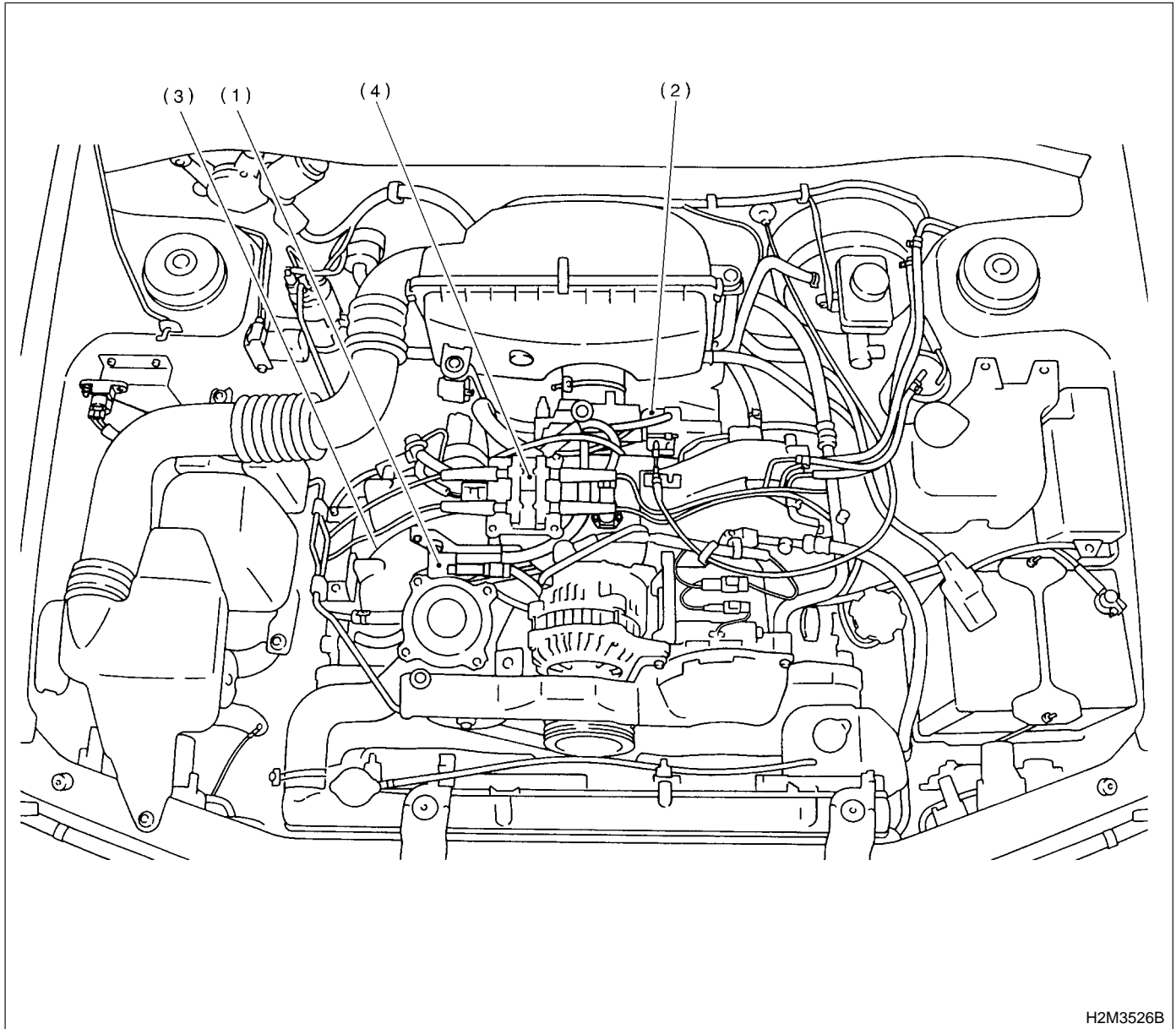

H2M3526B

- |  |                                  |
|--|----------------------------------|
| (1) Air assist injector solenoid valve | (3) Purge control solenoid valve |
| (2) Idle air control solenoid valve    | (4) Ignition coil & ignitor ASSY |



# ELECTRICAL COMPONENTS LOCATION

Engine (Diagnostics)

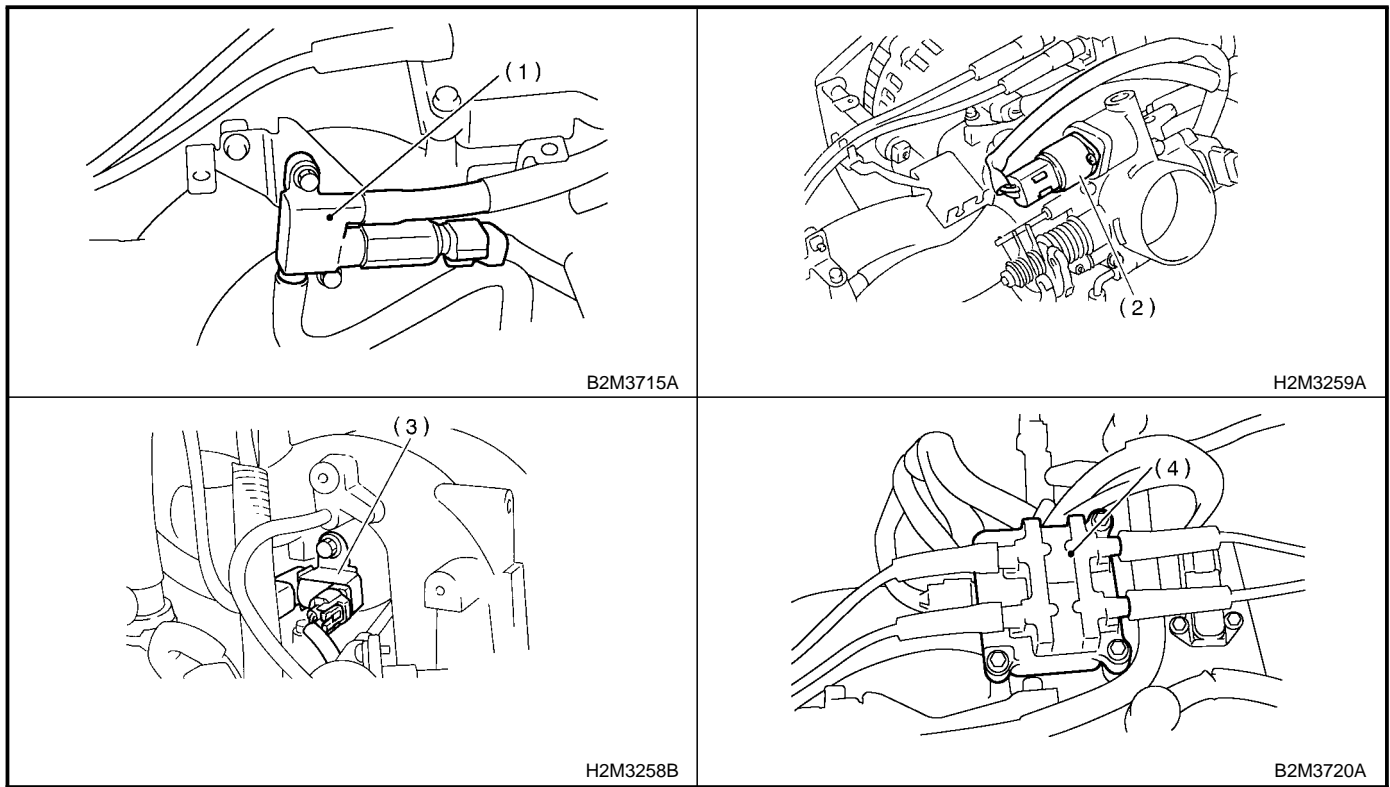

# ELECTRICAL COMPONENTS LOCATION

Engine (Diagnostics)

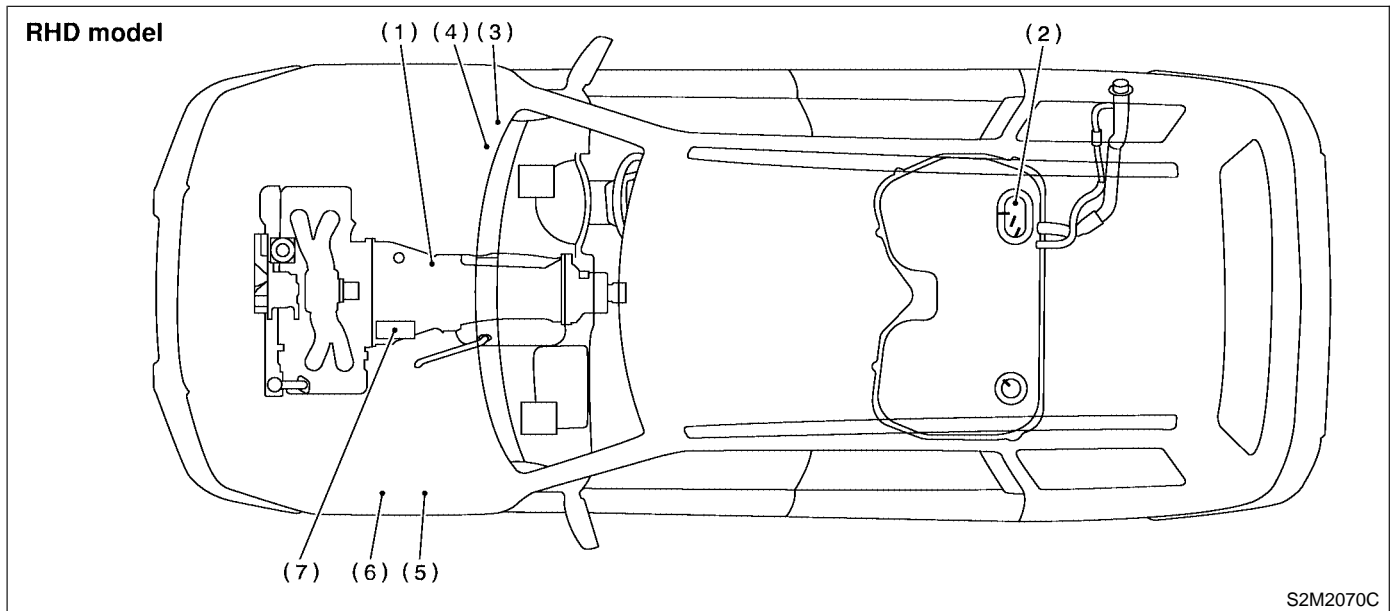
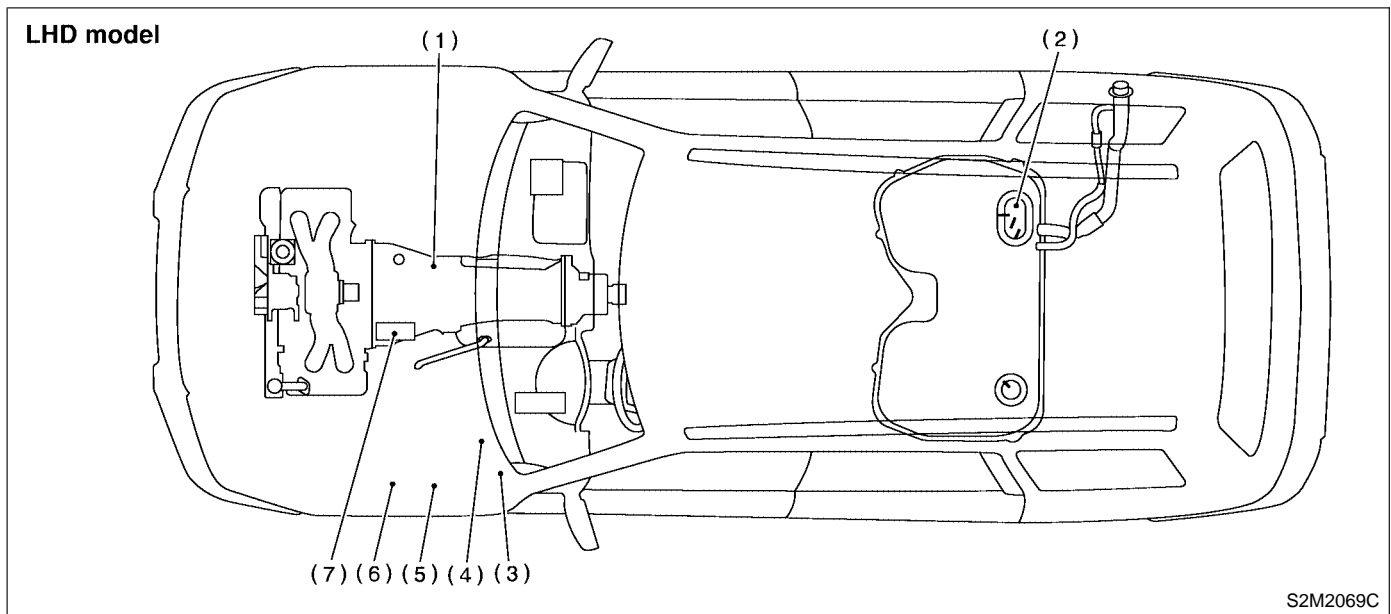

- |                      |                             |             |
|----------------------|-----------------------------|-------------|
| (1) Inhibitor switch | (4) Fuel pump relay         | (7) Starter |
| (2) Fuel pump        | (5) Radiator main fan relay |             |
| (3) Main relay       | (6) Radiator sub fan relay  |             |

# ELECTRICAL COMPONENTS LOCATION

Engine (Diagnostics)

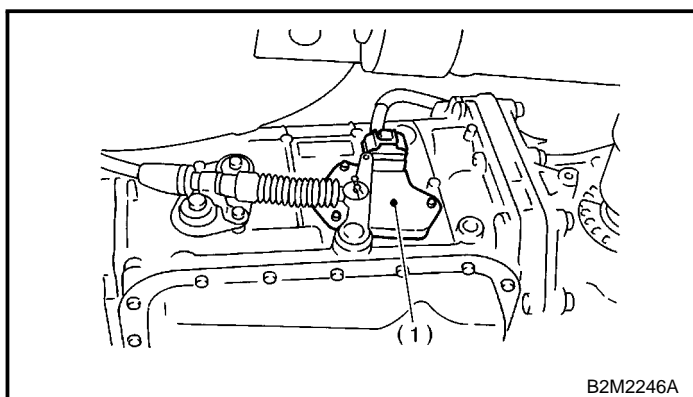

B2M2246A

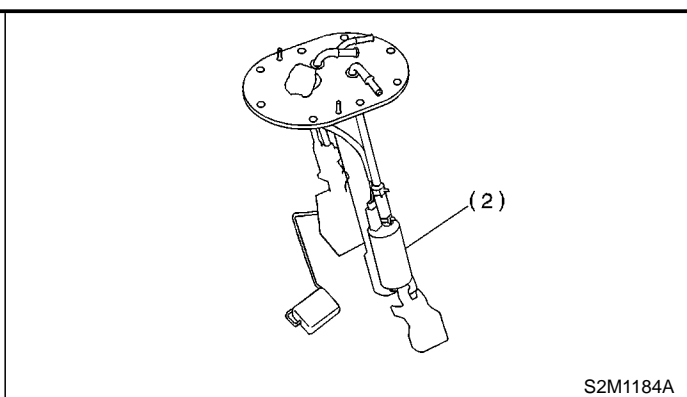

S2M1184A

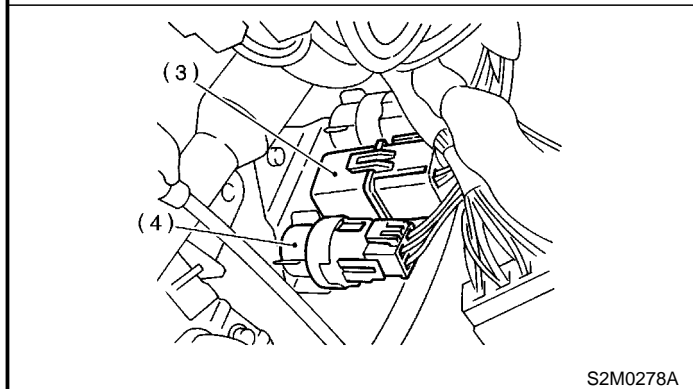

S2M0278A

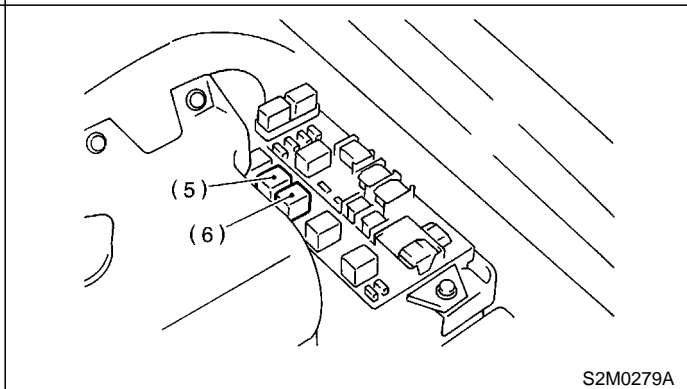

S2M0279A

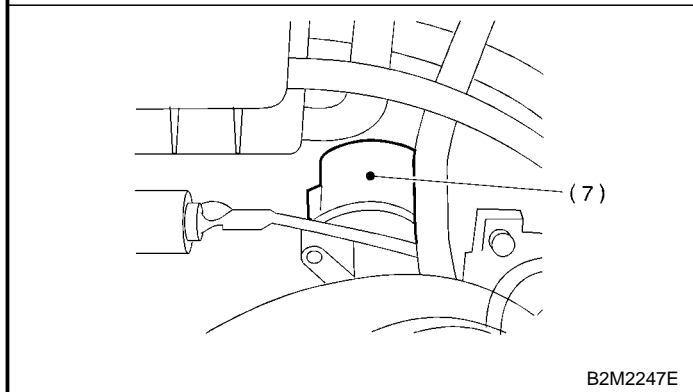

B2M2247E



# ELECTRICAL COMPONENTS LOCATION

Engine (Diagnostics)

## 2. TRANSMISSION S058507A1302

### ● MODULE

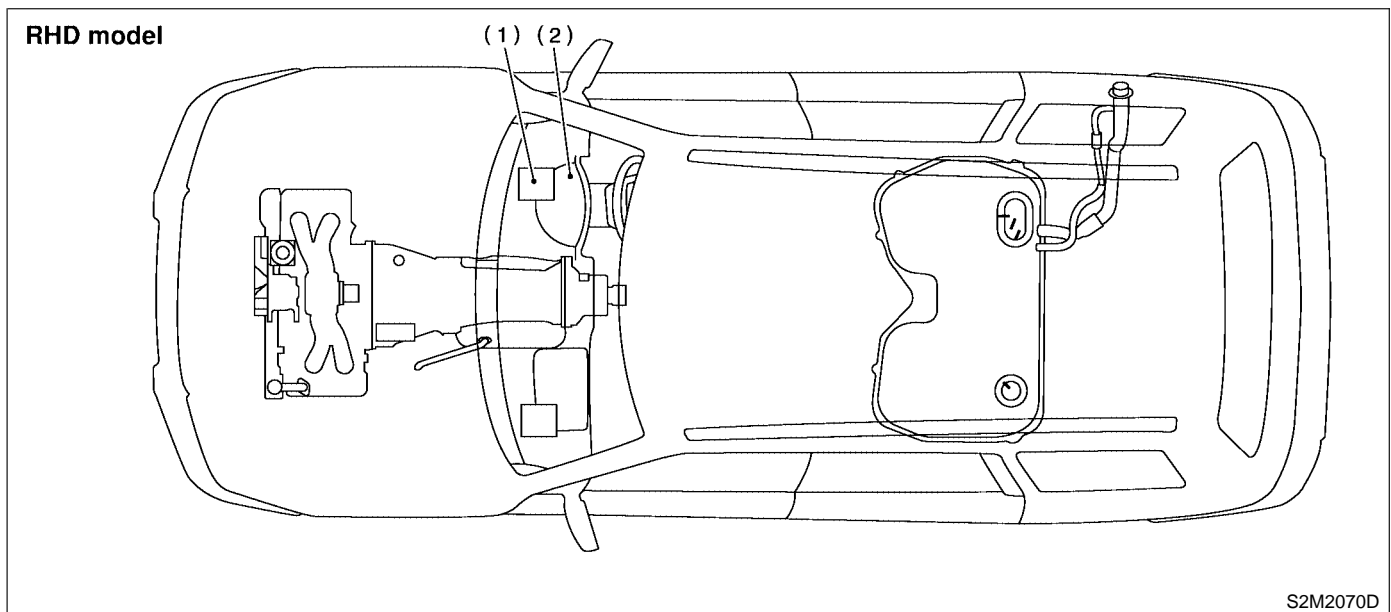
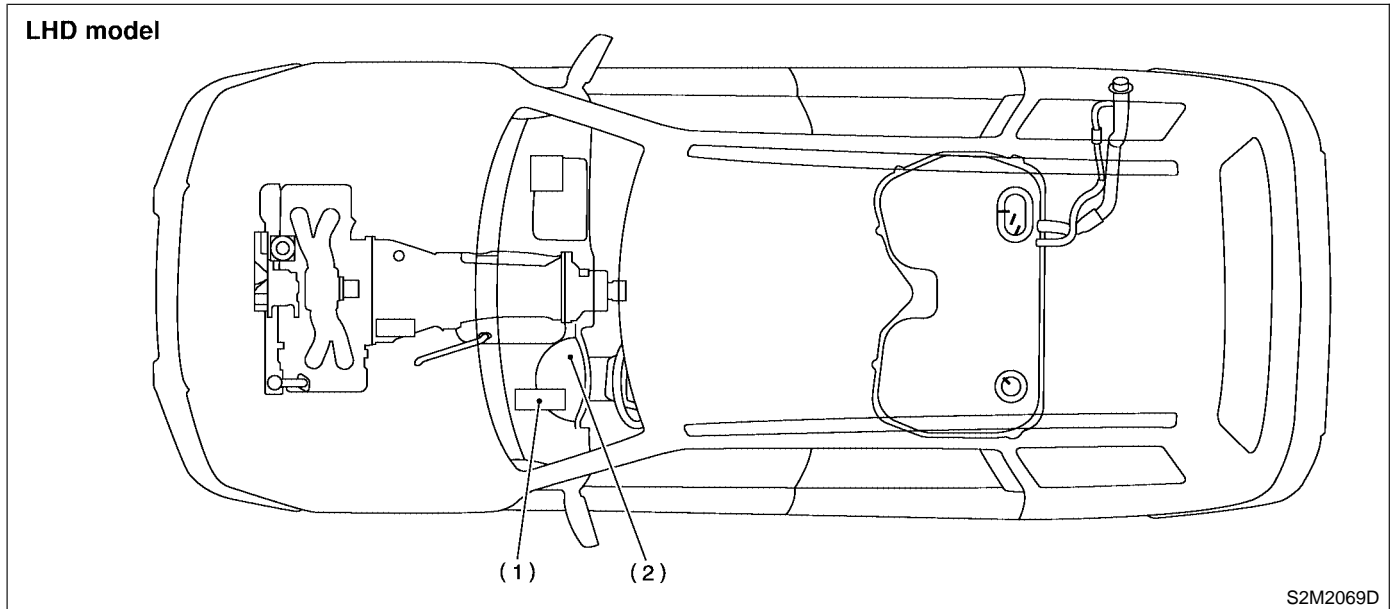

(1) Transmission Control Module (TCM) (for AT vehicles)

(2) AT diagnostic indicator light (for AT vehicles)

# ELECTRICAL COMPONENTS LOCATION

Engine (Diagnostics)

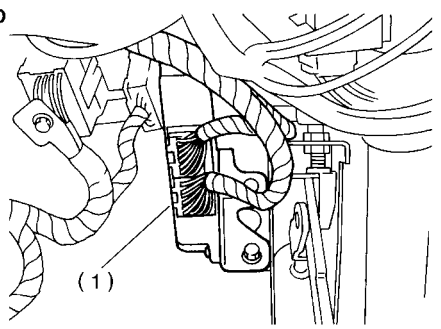
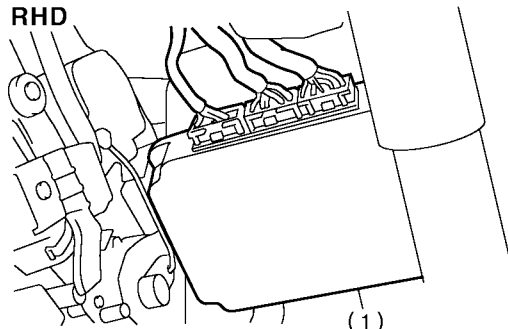
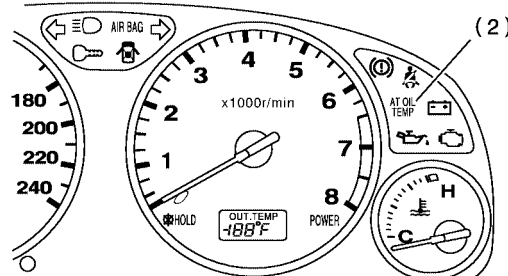
<p>LHD</p>  <p>(1)</p> <p>B3M1666G</p>	<p>RHD</p>  <p>(1)</p> <p>B3M1652B</p>
 <p>(2)</p> <p>S2M2104B</p>	<p>SUBARU.</p>

# ELECTRICAL COMPONENTS LOCATION

Engine (Diagnostics)

## ● SENSOR

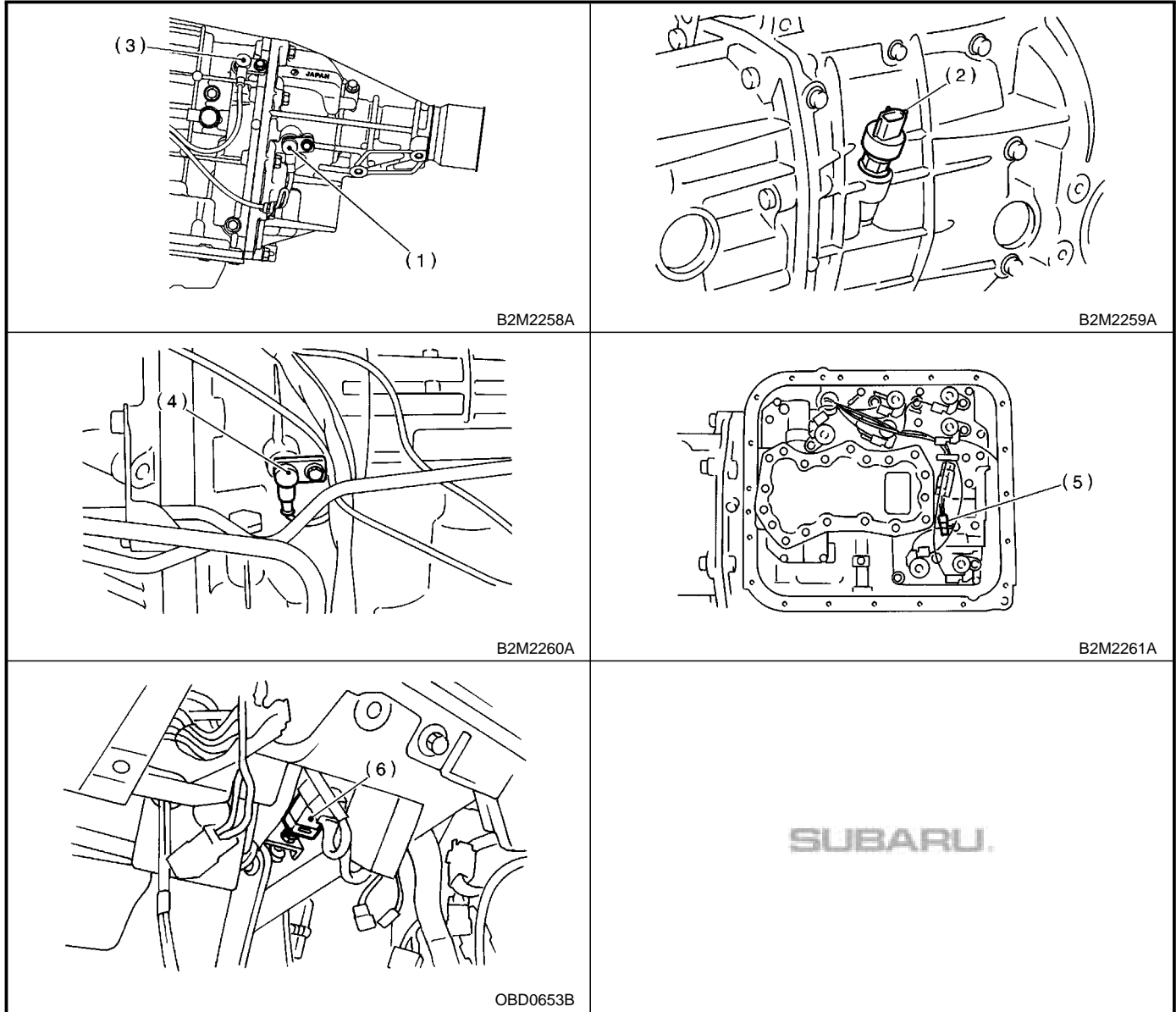

- (1) Rear vehicle speed sensor (for AT vehicles)
- (2) Front vehicle speed sensor (for MT vehicles)
- (3) Front vehicle speed sensor (for AT vehicles)
- (4) Torque converter turbine speed sensor
- (5) ATF temperature sensor (for AT vehicles)
- (6) Brake light switch

## ● SOLENOID VALVE AND SWITCH (AT VEHICLES)

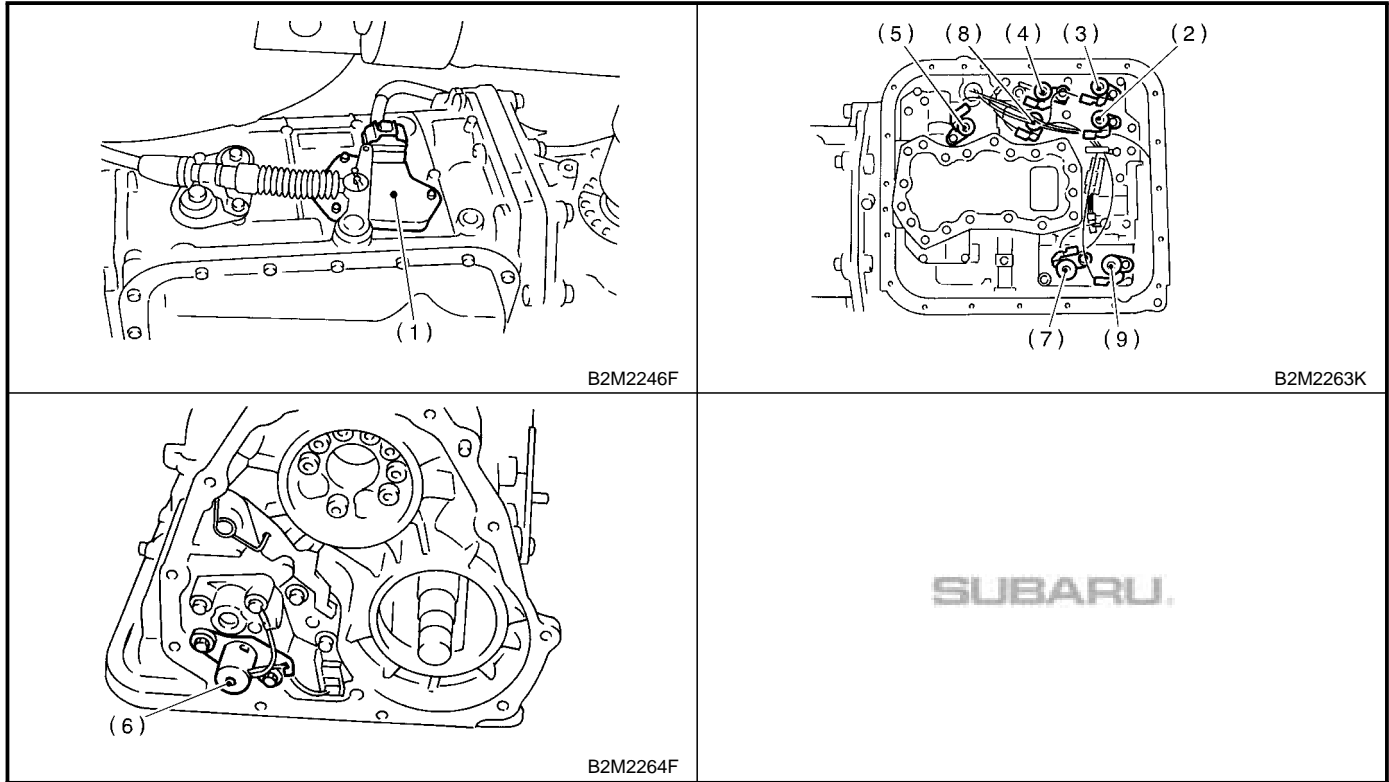

- (1) Inhibitor switch
- (2) Shift solenoid valve 1
- (3) Shift solenoid valve 2
- (4) Line pressure duty solenoid
- (5) Lock-up duty solenoid
- (6) Transfer duty solenoid
- (7) 2-4 brake duty solenoid
- (8) Low clutch timing solenoid valve
- (9) 2-4 brake timing solenoid valve

## ● SOLENOID VALVE AND SWITCH (MT VEHICLES)

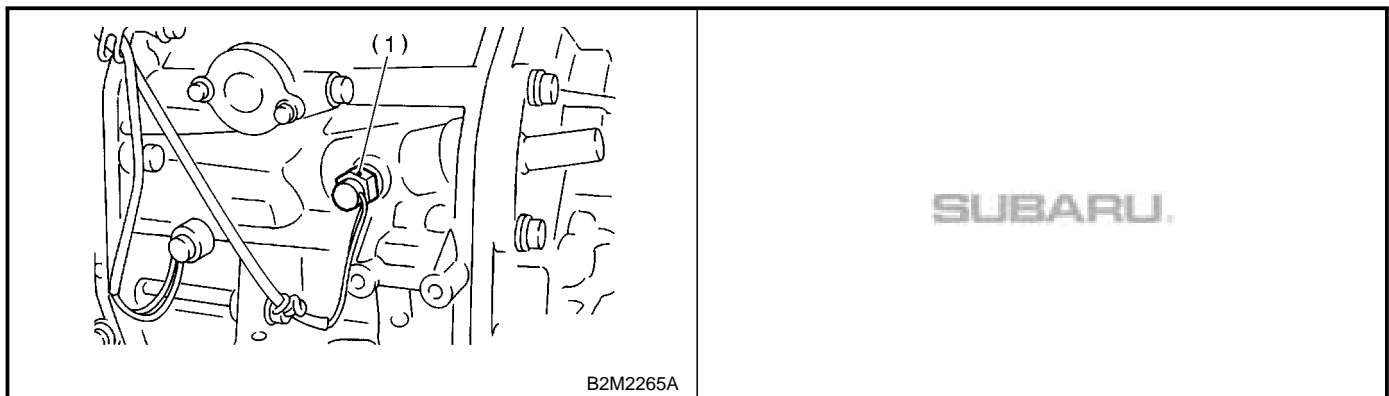

- (1) Neutral position switch

# ENGINE CONTROL MODULE (ECM) I/O SIGNAL

Engine (Diagnostics)

## 5. Engine Control Module (ECM) I/O Signal S058526

### A: ELECTRICAL SPECIFICATION S058526A08

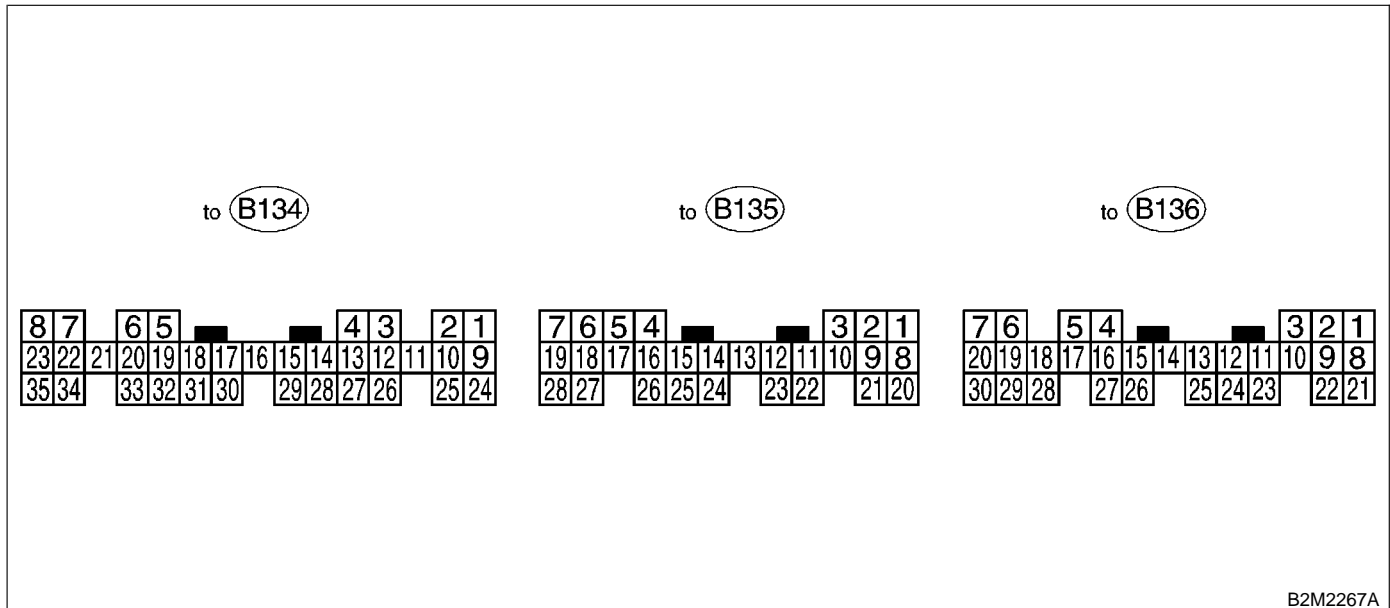

B2M2267A

Content		Con- nector No.	Termi- nal No.	Signal (V)		Note
				Ignition SW ON (Engine OFF)	Engine ON (Idling)	
Crankshaft position sensor	Signal (+)	B135	2	0	-7 — +7	Sensor output waveform
	Signal (-)	B135	9	0	0	—
	Shield	B135	10	0	0	—
Camshaft position sensor	Signal (+)	B135	1	0	-7 — +7	Sensor output waveform
	Signal (-)	B135	8	0	0	—
	Shield	B135	10	0	0	—
Throttle position sensor	Signal	B136	17	Fully closed: 0.2 — 1.0 Fully opened: 4.2 — 4.7		—
	Power sup- ply	B136	15	5	5	—
	GND (sen- sor)	B136	16	0	0	—
Rear oxy- gen sensor	Signal	B136	18	0	0 — 0.9	—
	Shield	B136	24	0	0	—
	GND (sen- sor)	B136	16	0	0	—
Front oxy- gen (A/F) sensor heater	Signal 1	B134	22	0 — 1.0	0 — 1.0	—
	Signal 2	B134	23	0 — 1.0	0 — 1.0	—
Rear oxygen sensor heater signal		B134	21	0 — 1.0	0 — 1.0	—
Engine coolant tempera- ture sensor	Signal	B136	14	1.0 — 1.4	1.0 — 1.4	After warm-up the engine.
	GND (sen- sor)	B136	16	0	0	After warm-up the engine.
Vehicle speed signal		B135	24	0 or 5	0 or 5	"5" and "0" are repeatedly dis- played when vehicle is driven.
Starter switch		B135	28	0	0	Cranking: 8 — 14



# ENGINE CONTROL MODULE (ECM) I/O SIGNAL

Engine (Diagnostics)

Content	Con- nector No.	Termi- nal No.	Signal (V)		Note	
			Ignition SW ON (Engine OFF)	Engine ON (Idling)		
A/C switch	B135	27	ON: 10 — 13 OFF: 0	ON: 13 — 14 OFF: 0	—	
Ignition switch	B135	7	10 — 13	13 — 14	—	
Neutral position switch	MT	B135	26	ON: 12±0.5 OFF: 0	On MT vehicle; Switch is ON when gear is in neutral posi- tion.	
	AT	B135	26	ON: 0 OFF: 12±0.5	ON AT vehicle; Switch is ON when shift is in "N" or "P" posi- tion.	
Test mode connector	B135	20	5	5	When connected: 0	
Knock sen- sor	Signal	B136	4	2.8	2.8	—
	Shield	B136	25	0	0	—
Back-up power supply	B136	9	10 — 13	13 — 14	Ignition switch "OFF": 10 — 13	
Control unit power sup- ply	B136	1	10 — 13	13 — 14	—	
	B136	2	10 — 13	13 — 14	—	
Sensor power supply	B136	15	5	5	—	
Line end check 1	B135	14	0	0	—	
Ignition control	#1, #2	B134	25	0	1 — 3.4	Waveform
	#3, #4	B134	26	0	1 — 3.4	Waveform
Fuel injec- tor	#1	B134	4	10 — 13	1 — 14	Waveform
	#2	B134	13	10 — 13	1 — 14	Waveform
	#3	B134	14	10 — 13	1 — 14	Waveform
	#4	B134	15	10 — 13	1 — 14	Waveform
Idle air control solenoid valve	Signal 1	B134	5	—	1 — 13	Waveform
	Signal 2	B134	6	—	1 — 13	Waveform
	Signal 3	B134	19	—	1 — 13	Waveform
	Signal 4	B134	20	—	1 — 13	Waveform
	Power sup- ply	B136	2	10 — 13	13 — 14	—
Fuel pump relay control	B134	29	ON: 0.5, or less OFF: 10 — 13	0.5, or less	—	
A/C relay control	B134	17	ON: 0.5, or less OFF: 10 — 13	ON: 0.5, or less OFF: 13 — 14	—	
Radiator fan relay 1 control	B134	3	ON: 0.5, or less OFF: 10 — 13	ON: 0.5, or less OFF: 13 — 14	—	
Radiator fan relay 2 control	B134	12	ON: 0.5, or less OFF: 10 — 13	ON: 0.5, or less OFF: 13 — 14	With A/C vehicles only	
Malfunction indicator lamp	B134	11	—	—	Light "ON": 1, or less Light "OFF": 10 — 14	
Engine speed output	B134	30	—	0 — 13, or more	Waveform	
Torque control 1 signal	B135	16	5	5	—	
Torque control 2 signal	B135	17	5	5	—	
Torque control cut sig- nal	B134	31	8	8	—	
Purge control solenoid valve	B134	2	ON: 1, or less OFF: 10 — 13	ON: 1, or less OFF: 13 — 14	—	
Atmo- spheric pressure sensor	Signal	B136	29	3.9 — 4.1	2.0 — 2.3	—
	Power sup- ply	B136	15	5	5	
	GND (sen- sor)	B136	16	0	0	
Fuel level sensor	B136	27	0.12 — 4.75	0.12 — 4.75	—	

# ENGINE CONTROL MODULE (ECM) I/O SIGNAL

Engine (Diagnostics)

Content	Con- nector No.	Termi- nal No.	Signal (V)		Note
			Ignition SW ON (Engine OFF)	Engine ON (Idling)	
AT diagnosis input sig- nal	B135	4	Less than 1 ←→ More than 4	Less than 1 ←→ More than 4	Waveform
Small light switch	B136	3	ON: 0 OFF: 10 — 13	ON: 0 OFF: 13 — 14	—
Blower fan switch	B136	30	ON: 0 OFF: 10 — 13	ON: 0 OFF: 13 — 14	—
Rear defogger switch	B135	21	ON: 0 OFF: 10 — 13	ON: 0 OFF: 13 — 14	—
Front oxygen (A/F) sen- sor signal 1	B136	19	2.8 — 3.2	2.8 — 3.2	—
Front oxygen (A/F) sen- sor signal 2	B136	6	2.4 — 2.7	2.4 — 2.7	—
Front oxygen (A/F) sen- sor signal 3	B136	7	0.2 — 4.9	0.2 — 4.9	—
Front oxygen (A/F) sen- sor signal 4	B136	20	0.2 — 4.9	0.2 — 4.9	—
Pressure sensor	B136	5	2.4 — 4.8	0.4 — 1.8	—
Intake air temperature sensor	B136	13	2.3 — 2.5	1.4 — 1.6	—
SSM/GST communica- tion line	B135	3	Less than 1 ←→ More than 4	Less than 1 ←→ More than 4	—
GND (sensors)	B136	16	0	0	—
GND (injectors)	B134	7	0	0	—
GND (ignition system)	B134	27	0	0	—
GND (power supply)	B134	8	0	0	—
GND (control systems)	B136	21	0	0	—
	B136	22	0	0	—
GND (oxygen sensor heater 1)	B134	35	0	0	—
GND (oxygen sensor heater 2)	B134	34	0	0	—

## 6. Engine Condition Data S058530

### A: ELECTRICAL SPECIFICATION

S058530A08

Content	Specified data
Engine load	1.6 — 2.9 (%): Idling
	6.4 — 12.8 (%): 2,500 rpm racing

Measuring condition:

- After warm-up the engine.
- Gear position is in “N” or “P” position.
- A/C is turned OFF.
- All accessory switches are turned OFF.

# TRANSMISSION CONTROL MODULE (TCM) I/O SIGNAL

Engine (Diagnostics)

## 7. Transmission Control Module (TCM) I/O Signal S058506

### A: ELECTRICAL SPECIFICATION S058506A08

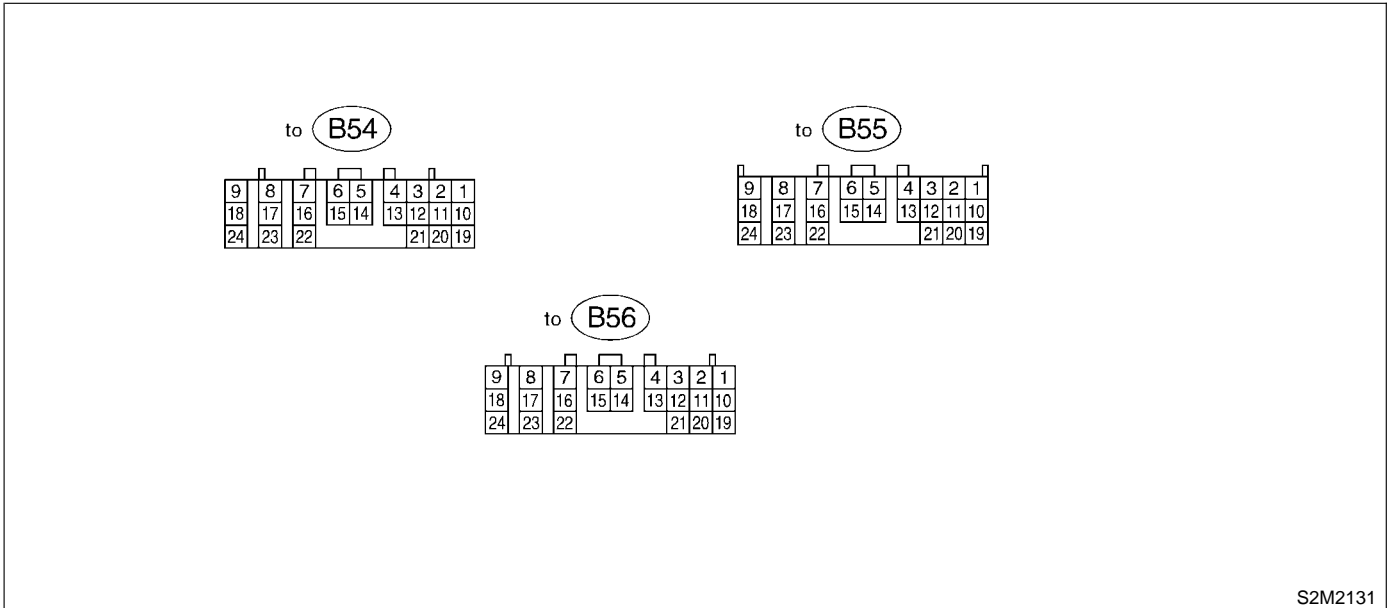

S2M2131

Check with ignition switch ON.						
Content	Connector No.	Terminal No.	Measuring conditions	Voltage (V)	Resistance to body (ohms)	
Back-up power supply	B56	1	Ignition switch OFF	10 — 16	—	
Ignition power supply	B54	23	Ignition switch ON (with engine OFF)	10 — 16	—	
	B54	24				
Inhibitor switch	"P" range switch	B55	1	Select lever in "P" range	Less than 1	—
				Select lever in any other than "P" range (except "N" range)	More than 8	
	"N" range switch	B55	14	Select lever in "N" range	Less than 1	—
				Select lever in any other than "N" range (except "P" range)	More than 8	
	"R" range switch	B55	3	Select lever in "R" range	Less than 1	—
				Select lever in any other than "R" range	More than 9.5	
	"D" range switch	B55	4	Select lever in "D" range	Less than 1	—
				Select lever in any other than "D" range	More than 9.5	
	"3" range switch	B55	5	Select lever in "3" range	Less than 1	—
				Select lever in any other than "3" range	More than 9.5	
	"2" range switch	B55	6	Select lever in "2" range	Less than 1	—
				Select lever in any other than "2" range	More than 9.5	
	"1" range switch	B55	7	Select lever in "1" range	Less than 1	—
				Select lever in any other than "1" range	More than 9.5	
Brake switch	B55	12	Brake pedal depressed.	More than 10.5	—	
			Brake pedal released.	Less than 1		
ABS signal	B55	21	ABS switch ON	Less than 1	—	
			ABS switch OFF	6.5 — 15		

# TRANSMISSION CONTROL MODULE (TCM) I/O SIGNAL

Engine (Diagnostics)

Check with ignition switch ON.					
Content	Connector No.	Terminal No.	Measuring conditions	Voltage (V)	Resistance to body (ohms)
Hold switch	B55	16	Hold switch ON	Less than 1	—
			Hold switch OFF	More than 8	
Power switch	B55	23	Power switch ON	Less than 1	—
			Power switch OFF	More than 10	
Kick-down switch	B55	11	Throttle fully opened.	Less than 1	—
			Throttle fully closed.	More than 6.5	
POWER indicator light	B56	11	Light ON	Less than 1	—
			Light OFF	More than 9	
AT OIL TEMP indicator light	B56	10	Light ON	Less than 1	—
			Light OFF	More than 9	
Throttle position sensor	B54	3	Throttle fully closed.	0.3 — 0.7	—
			Throttle fully open.	4.0 — 4.6	
Throttle position sensor power supply	B54	2	Ignition switch ON (With engine OFF)	4.8 — 5.3	—
ATF temperature sensor	B54	11	ATF temperature 20°C (68°F)	1.6 — 2.0	2.1 — 2.9 k
			ATF temperature 80°C (176°F)	0.4 — 0.9	275 — 375
Rear vehicle speed sensor	B55	24	Vehicle stopped.	0	450 — 650
			Vehicle speed at least 20 km/h (12 MPH)	More than 1 (AC range)	
Front vehicle speed sensor	B55	18	Vehicle speed at least 20 km/h (12 MPH)	More than 1 (AC range)	450 — 650
Torque converter turbine speed sensor	B55	8	Engine idling after warm-up. (D range)	0	450 — 650
			Engine idling after warm-up. (N range)	More than 1 (AC range)	
Vehicle speed output signal	B56	17	Vehicle speed at most 10 km/h (6 MPH)	Less than 1 ← → More than 4	—
Engine speed signal	B55	17	Ignition switch ON (with engine OFF)	More than 10.5	—
			Ignition switch ON (with engine ON)	8 — 11	
Cruise set signal	B55	22	When cruise control is set (SET lamp ON)	Less than 1	—
			When cruise control is not set (SET lamp OFF)	More than 6.5	
Torque control signal 1	B56	5	Ignition switch ON (with engine ON)	4	—
Torque control signal 2	B56	14	Ignition switch ON (with engine ON)	4	—
Torque control cut signal	B55	10	Ignition switch ON	8	—
Intake manifold pressure signal	B54	1	Engine idling after warm-up.	1.2 — 1.8	—
Shift solenoid 1	B54	22	1st or 4th gear	More than 9	10 — 16
			2nd or 3rd gear	Less than 1	
Shift solenoid 2	B54	5	1st or 2nd gear	More than 9	10 — 16
			3rd or 4th gear	Less than 1	

# TRANSMISSION CONTROL MODULE (TCM) I/O SIGNAL

Engine (Diagnostics)

Check with ignition switch ON.					
Content	Connector No.	Terminal No.	Measuring conditions	Voltage (V)	Resistance to body (ohms)
Line pressure duty solenoid	B54	9	Ignition switch ON (with engine OFF) Throttle fully closed after warm-up.	1.5 — 4.0	2.0 — 4.5
			Ignition switch ON (with engine OFF) Throttle fully open after warm-up.	Less than 0.5	
Lock-up duty solenoid	B54	7	When lock up occurs.	More than 8.5	10 — 17
			When lock up is released.	Less than 0.5	
Transfer duty solenoid	B54	6	Fuse on FWD switch	More than 8.5	10 — 17
			Fuse removed from FWD switch (with throttle fully open and with select lever in 1st gear).	Less than 0.5	
2-4 brake duty solenoid	B54	18	Ignition switch ON (with engine OFF) Throttle fully closed after warm-up.	1.5 — 4.0	2.0 — 4.5
			Ignition switch ON (with engine OFF) Throttle fully open after warm-up.	Less than 0.5	
2-4 brake timing solenoid	B54	16	1st gear	Less than 1	10 — 16
			3rd gear	More than 9	
Low clutch timing solenoid	B54	15	2nd gear	Less than 1	10 — 16
			4th gear	More than 9	
Sensor ground line 1	B54	20	—	0	Less than 1
Sensor ground line 2	B55	9	—	0	Less than 1
Sensor ground line 3	B54	10	—	0	Less than 1
Sensor ground line 4	B54	19	—	0	Less than 1
System ground line	B56	19	—	0	Less than 1
	B54	20			
FWD switch	B55	20	Fuse removed.	6 — 9.1	—
			Fuse installed.	Less than 1	
FWD indicator light	B56	2	Fuse ON FWD switch	Less than 1	—
			Fuse removed from FWD switch	More than 9	
Data link signal (Subaru Select Monitor)	B56	15	—	—	—
		6	—	—	

## 8. Data Link Connector S058505

### A: NOTE S058505A15

- 1) This connector is used both for OBD-II general scan tools and the Subaru Select Monitor.
- 2) Terminal No. 4 to No. 6 of the data link connector is used for the Subaru Select Monitor signal.

### CAUTION:

**Do not connect any scan tools other than the OBD-II general scan tools and the Subaru Select Monitor, because the circuit for the Subaru Select Monitor may be damaged.**

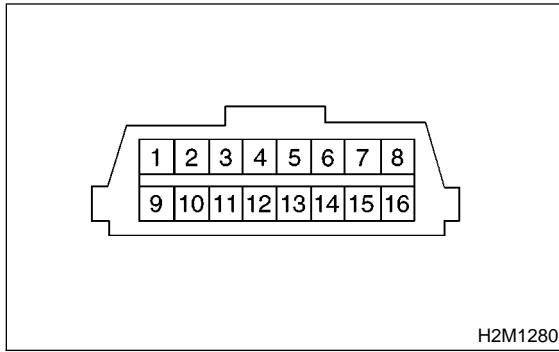

Terminal No.	Contents	Terminal No.	Contents
1	Power supply	9	Blank
2	Blank	10	K line of ISO 9141 CARB
3	Blank	11	Blank
4	Subaru Select Monitor signal (ECM to Subaru Select Monitor)*	12	Ground
5	Subaru Select Monitor signal (Subaru Select Monitor to ECM)*	13	Ground
6	Line end check signal 1	14	Blank
7	Blank	15	Blank
8	Blank	16	Blank

\*: Circuit only for Subaru Select Monitor

# OBD-II GENERAL SCAN TOOL

Engine (Diagnostics)

## 9. OBD-II General Scan Tool S058527

### A: OPERATION S058527A16

#### 1. HOW TO USE OBD-II GENERAL SCAN TOOL S058527A1601

- 1) Prepare a general scan tool (OBD-II general scan tool) required by SAE J1978.
- 2) Connect the OBD-II general scan tool to the data link connector (A) located in the lower portion of the instrument panel (on the driver's side).

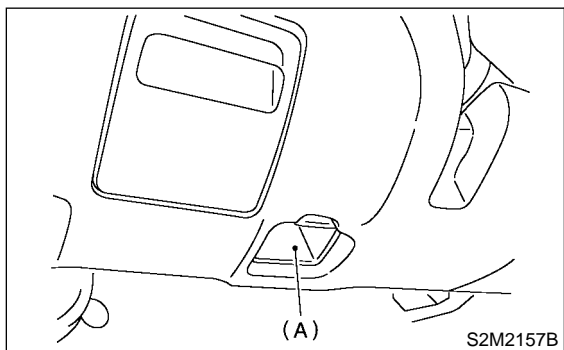

- 3) Using the OBD-II general scan tool, call up diagnostic trouble code(s) and freeze frame data. OBD-II general scan tool functions consist of:

- (1) MODE \$01: Current powertrain diagnostic data
- (2) MODE \$02: Powertrain freeze frame data
- (3) MODE \$03: Emission-related powertrain diagnostic trouble codes
- (4) MODE \$04: Clear/Reset emission-related diagnostic information

Read out data according to repair procedures. (For detailed operation procedures, refer to the OBD-II General Scan Tool Operation Manual.)

#### NOTE:

For details concerning diagnostic trouble codes, refer to the List of Diagnostic Trouble Code (DTC). <Ref. to EN(SOHC)-80, List of Diagnostic Trouble Code (DTC).>

#### 2. MODE \$01 (CURRENT POWERTRAIN DIAGNOSTIC DATA) S058527A1602

Refers to data denoting the current operating condition of analog input/output, digital input/output and/or the powertrain system.

A list of the support data and PID (Parameter Identification) codes are shown in the following table.

PID	Data	Unit of measure
01	Number of emission-related powertrain trouble codes and MIL status	ON/OFF
03	Fuel system control status	—
04	Calculated engine load value	%
05	Engine coolant temperature	°C
06	Short term fuel trim	%
07	Long term fuel trim	%
0B	Intake manifold absolute pressure	kPa
0C	Engine revolution	rpm
0D	Vehicle speed	km/h
0E	Ignition timing advance	°
0F	Intake air temperature	°C
10	Air flow rate from pressure sensor	g/sec
11	Throttle valve opening angle	%
13	Check whether oxygen sensor is installed.	—
15	Oxygen sensor output voltage and short term fuel trim associated with oxygen sensor—bank 2	V and %
24	A/F sensor 1 output voltage and short term fuel trim associated with A/F sensor 1	V and %
1C	On-board diagnosis system	—

#### NOTE:

Refer to OBD-II general scan tool manufacturer's instruction manual to access generic OBD-II PIDs (MODE \$01).



**3. MODE \$02 (POWERTRAIN FREEZE FRAME DATA)** S058527A1603

Refers to data denoting the operating condition when trouble is sensed by the on-board diagnosis system. A list of the support data and PID (Parameter Identification) codes are shown in the following table.

PID	Data	Unit of measure
02	Trouble code that caused CARB required freeze frame data storage	—
03	Fuel system control status	—
04	Calculated engine load value	%
05	Engine coolant temperature	°C
06	Short term fuel trim	%
07	Long term fuel trim	%
0B	Intake manifold absolute pressure	kPa
0C	Engine revolution	rpm
0D	Vehicle speed	km/h

**NOTE:**

Refer to OBD-II general scan tool manufacturer's instruction manual to access freeze frame data (MODE \$02).

**4. MODE \$03 (EMISSION-RELATED POWERTRAIN DIAGNOSTIC TROUBLE CODE)** S058527A1604

Refer to Read Diagnostic Trouble Code for information about data denoting emission-related powertrain diagnostic trouble codes. <Ref. to EN(SOHC)-41, Read Diagnostic Trouble Code.>

**5. MODE \$04 (CLEAR/RESET EMISSION-RELATED DIAGNOSTIC INFORMATION)** S058527A1605

Refers to the mode used to clear or reset emission-related diagnostic information (OBD-II trouble diagnostic information).

**NOTE:**

Refer to OBD-II general scan tool manufacturer's instruction manual to clear or reset emission-related diagnostic information (MODE \$04).

# SUBARU SELECT MONITOR

Engine (Diagnostics)

## 10. Subaru Select Monitor S058503

### A: OPERATION S058503A16

#### 1. HOW TO USE SUBARU SELECT MONITOR S058503A1601

1) Prepare Subaru Select Monitor kit. <Ref. to EN(SOHC)-8, PREPARATION TOOL, General Description.>

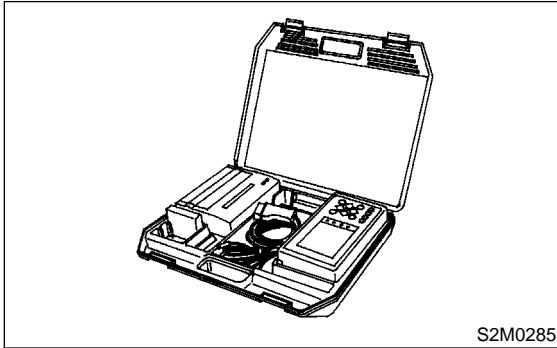

2) Connect diagnosis cable to Subaru Select Monitor.

3) Insert cartridge into Subaru Select Monitor. <Ref. to EN(SOHC)-8, PREPARATION TOOL, General Description.>

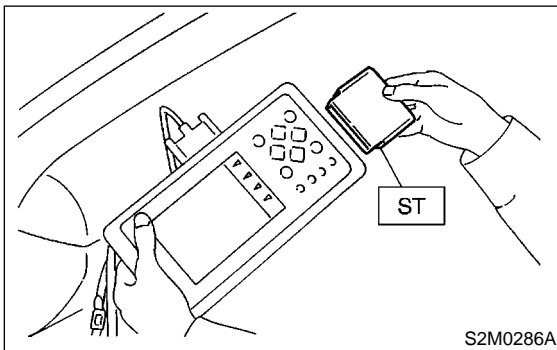

4) Connect Subaru Select Monitor to data link connector.

(1) Data link connector (A) located in the lower portion of the instrument panel (on the driver's side).

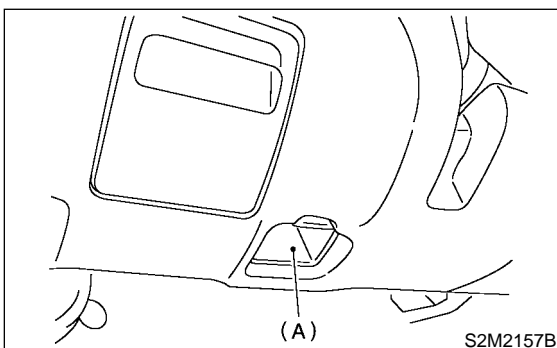

(2) Connect diagnosis cable to data link connector.

### CAUTION:

Do not connect scan tools except for Subaru Select Monitor and OBD-II general scan tool.

5) Turn ignition switch to ON (engine OFF) and Subaru Select Monitor switch to ON.

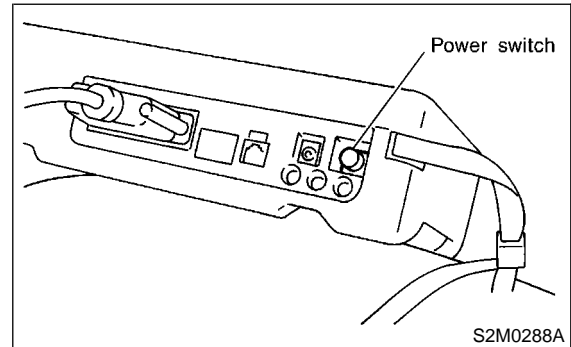

6) Using Subaru Select Monitor, call up diagnostic trouble code(s) and various data, then record them.

#### 2. READ DIAGNOSTIC TROUBLE CODE (DTC) FOR ENGINE. (NORMAL MODE)

S058503A1602

Refer to Read Diagnostic Trouble Code for information about how to indicate DTC. <Ref. to EN(SOHC)-41, Read Diagnostic Trouble Code.>

#### 3. READ DIAGNOSTIC TROUBLE CODE (DTC) FOR ENGINE. (OBD MODE) S058503A1603

Refer to Read Diagnostic Trouble Code for information about how to indicate DTC. <Ref. to EN(SOHC)-41, Read Diagnostic Trouble Code.>

## 4. READ CURRENT DATA FOR ENGINE. (NORMAL MODE) S058503A1604

- 1) On the «Main Menu» display screen, select the {Each System Check} and press the [YES] key.
  - 2) On the «System Selection Menu» display screen, select the {Engine Control System} and press the [YES] key.
  - 3) Press the [YES] key after displayed the information of engine type.
  - 4) On the «Engine Diagnosis» display screen, select the {Current Data Display & Save} and press the [YES] key.
  - 5) On the «Data Display Menu» display screen, select the {Data Display} and press the [YES] key.
  - 6) Using the scroll key, move the display screen up or down until the desired data is shown.
- A list of the support data is shown in the following table.

Contents	Display	Unit of measure
Battery voltage	Battery Voltage	V
Vehicle speed signal	Vehicle Speed	km/h or MPH
Engine speed signal	Engine Speed	rpm
Engine coolant temperature signal	Coolant Temp.	°C or °F
Ignition timing signal	Ignition Timing	deg
Throttle position signal	Throttle Opening Angle	%
Throttle position signal	Throttle Sensor Voltage	V
Injection pulse width	Fuel Injection #1 Pulse	ms
Idle air control signal	ISC Valve Step	STEP
Engine load data	Engine Load	%
Front oxygen (A/F) sensor output signal	A/F Sensor #1	—
Rear oxygen sensor output signal	Rear O2 Sensor	V
Short term fuel trim	A/F Correction #1	%
Knock sensor signal	Knocking Correction	deg
Atmospheric absolute pressure signal	Atmosphere Pressure	mmHg or kPa or inHg or psi
Intake manifold relative pressure signal	Mani. Relative Pressure	mmHg or kPa or inHg or psi
Intake manifold absolute pressure signal	Mani. Absolute Pressure	mmHg or kPa or inHg or psi
A/F correction (short term fuel trim) by rear oxygen sensor	A/F Correction #3	%
Long term whole fuel trim	A/F Learning #1	%
Front oxygen (A/F) sensor heater current	Front O2 Heater #1	A
Rear oxygen sensor heater current	Rear O2 Heater Current	A
Canister purge control solenoid valve duty ratio	CPC Valve Duty Ratio	%
Fuel level signal	Fuel Level	V
Intake air temperature signal	Intake Air Temp.	°C or °F
Learned ignition timing	Learned Ignition Timing	deg
Ignition switch signal	Ignition Switch	ON or OFF
Test mode connector signal	Test Mode Signal	ON or OFF
Neutral position switch signal	Neutral Position Switch	ON or OFF
Air conditioning switch signal	A/C Switch	ON or OFF
Air conditioning signal	A/C Compressor Signal	ON or OFF
Radiator main fan relay signal	Radiator Fan Relay #1	ON or OFF
Fuel pump relay signal	Fuel Pump Relay	ON or OFF
Knocking signal	Knocking Signal	ON or OFF
Radiator sub fan relay signal	Radiator Fan Relay #2	ON or OFF
Power steering switch signal	P/S Switch	ON or OFF
Engine torque control signal #1	Torque Control Signal #1	ON or OFF
Engine torque control signal #2	Torque Control Signal #2	ON or OFF
Engine torque control permission signal	Torque Permission Signal	ON or OFF
Rear oxygen sensor rich signal	Rear O2 Rich Signal	ON or OFF

# SUBARU SELECT MONITOR

Engine (Diagnostics)

Contents	Display	Unit of measure
Starter switch signal	Starter Switch Signal	ON or OFF
Idle switch signal	Idle Switch Signal	ON or OFF
Crankshaft position sensor signal	Crankshaft Position Sig.	ON or OFF
Camshaft position sensor signal	Camshaft Position Sig.	ON or OFF
Rear defogger switch signal	Rear Defogger Switch	ON or OFF
Blower fan switch signal	Blower Fan Switch	ON or OFF
Small light switch signal	Light Switch	ON or OFF
Air assist injector solenoid valve signal	Assist Air Sol. Valve	ON or OFF
AT vehicle ID signal	AT Vehicle ID Signal	ON or OFF

**NOTE:**

For detailed operation procedure, refer to the SUBARU SELECT MONITOR OPERATION MANUAL.

## 5. READ CURRENT DATA FOR ENGINE. (OBD MODE) S058503A1605

- 1) On the «Main Menu» display screen, select the {Each System Check} and press the [YES] key.
  - 2) On the «System Selection Menu» display screen, select the {Engine Control System} and press the [YES] key.
  - 3) Press the [YES] key after displayed the information of engine type.
  - 4) On the «Engine Diagnosis» display screen, select the {OBD System} and press the [YES] key.
  - 5) On the «OBD Menu» display screen, select the {Current Data Display & Save} and press the [YES] key.
  - 6) On the «Data Display Menu» display screen, select the {Data Display} and press the [YES] key.
  - 7) Using the scroll key, move the display screen up or down until the desired data is shown.
- A list of the support data is shown in the following table.

Contents	Display	Unit of measure
Number of diagnosis code	Number of Diagnosis Code	—
Malfunction indicator lamp status	MI (MIL)	Complete or incomplete
Monitoring test of misfire	Misfire monitoring	Complete or incomplete
Monitoring test of fuel system	Fuel system monitoring	Complete or incomplete
Monitoring test of comprehensive component	Component monitoring	Complete or incomplete
Test of catalyst	Catalyst Diagnosis	No support
Test of heated catalyst	Heated catalyst	No support
Test of evaporative emission purge control system	Evaporative purge system	No support
Test of secondary air system	Secondary air system	No support
Test of air conditioning system refrigerant	A/C system refrigerant	No support
Test of oxygen sensor	Oxygen sensor	Complete or incomplete
Test of oxygen sensor heater	O2 Heater Diagnosis	Complete or incomplete
Test of EGR system	EGR system	No support
Air fuel ratio control system for bank 1	Fuel System for Bank 1	—
Engine load data	Calculated load value	%
Engine coolant temperature signal	Coolant Temp.	°C or °F
Short term fuel trim by front oxygen (A/F) sensor	Short term fuel trim B1	%
Long term fuel trim by front oxygen (A/F) sensor	Long term fuel trim B1	%
Intake manifold absolute pressure signal	Mani. Absolute Pressure	mmHg or kPa or inHg or psi
Engine speed signal	Engine Speed	rpm
Vehicle speed signal	Vehicle Speed	km/h or MPH
Ignition timing advance for #1 cylinder	Ignition timing adv. #1	°
Intake air temperature signal	Intake Air Temp.	°C or °F
Intake air amount	Mass Air Flow	g/s
Throttle position signal	Throttle Opening Angle	%
A/F sensor equipment	A/F sensor	ON or OFF
Rear oxygen sensor output signal	Oxygen Sensor #12	V
Air fuel ratio correction by rear oxygen sensor	Short term fuel trim #12	%
On-board diagnostic system	OBD System	—

**NOTE:**

For detailed operation procedure, refer to the SUBARU SELECT MONITOR OPERATION MANUAL.

# SUBARU SELECT MONITOR

Engine (Diagnostics)

## 6. READ FREEZE FRAME DATA FOR ENGINE. (OBD MODE) S058503A1606

- 1) On the «Main Menu» display screen, select the {Each System Check} and press the [YES] key.
  - 2) On the «System Selection Menu» display screen, select the {Engine Control System} and press the [YES] key.
  - 3) Press the [YES] key after displayed the information of engine type.
  - 4) On the «Engine Diagnosis» display screen, select the {OBD System} and press the [YES] key.
  - 5) On the «OBD Menu» display screen, select the {Freeze Frame Data} and press the [YES] key.
- A list of the support data is shown in the following table.

Contents	Display	Unit of measure
Diagnostic trouble code (DTC) for freeze frame data	Freeze frame data	DTC
Air fuel ratio control system for bank 1	Fuel system for Bank1	ON or OFF
Engine load data	Engine Load	%
Engine coolant temperature signal	Coolant Temp.	°C or °F
Short term fuel trim by front oxygen (A/F) sensor	Short term fuel trim B1	%
Long term fuel trim by front oxygen (A/F) sensor	Long term fuel trim B1	%
Intake manifold absolute pressure signal	Mani. Absolute Pressure	mmHg or kPa or inHg or psi
Engine speed signal	Engine Speed	rpm
Vehicle speed signal	Vehicle Speed	km/h or MPH

NOTE:

For detailed operation procedure, refer to the SUBARU SELECT MONITOR OPERATION MANUAL.

## 7. READ OXYGEN SENSOR MONITORING TEST RESULTS DATA FOR ENGINE. (OBD MODE) S058503A1607

- 1) On the «Main Menu» display screen, select the {Each System Check} and press the [YES] key.
  - 2) On the «System Selection Menu» display screen, select the {Engine Control System} and press the [YES] key.
  - 3) Press the [YES] key after displayed the information of engine type.
  - 4) On the «Engine Diagnosis» display screen, select the {OBD System} and press the [YES] key.
  - 5) On the «OBD Menu» display screen, select the {O2 Sensor Monitor} and press the [YES] key.
  - 6) On the «O2 Sensor Select» display screen, select the {Bank 1-Sensor1} or {Bank 1-Sensor2} and press the [YES] key.
- Bank 1-Sensor1 indicates the front oxygen or A/F sensor, and Bank 1-Sensor2 indicates the rear oxygen sensor.
  - A list of the support data is shown in the following table.

Contents	Display	Unit of measure
Oxygen sensor for monitoring test	<O2 Sensor Monitor (-----)>	—
Rich to lean oxygen sensor threshold voltage	Rich to lean sensor volt	V
Lean to rich oxygen sensor threshold voltage	Lean to rich sensor volt	V
Low oxygen sensor voltage for switch time calculation	Low sensor voltage	V
High oxygen sensor voltage for switch time calculation	High sensor voltage	V
Rich to lean oxygen sensor switch time	Rich to lean switch time	sec
Lean to rich oxygen sensor switch time	Lean to rich switch time	sec
Maximum oxygen sensor voltage for test cycle	Maximum sensor Voltage	V
Minimum oxygen sensor voltage for test cycle	Minimum sensor Voltage	V

NOTE:

For detailed operation procedure, refer to the SUBARU SELECT MONITOR OPERATION MANUAL.

## 8. LED OPERATION MODE FOR ENGINE S058503A1608

- 1) On the «Main Menu» display screen, select the {Each System Check} and press the [YES] key.
  - 2) On the «System Selection Menu» display screen, select the {Engine Control System} and press the [YES] key.
  - 3) Press the [YES] key after displayed the information of engine type.
  - 4) On the «Engine Diagnosis» display screen, select the {Current Data Display & Save} and press the [YES] key.
  - 5) On the «Data Display Menu» display screen, select the {Data & LED Display} and press the [YES] key.
  - 6) Using the scroll key, move the display screen up or down until the desired data is shown.
- A list of the support data is shown in the following table.

Contents	Display	Message	LED "ON" requirements
Ignition switch signal	Ignition Switch	ON or OFF	When ignition switch is turned ON.
Test mode connector signal	Test Mode Signal	ON or OFF	When test mode connector is connected.
Neutral position switch signal	Neutral Position Switch	ON or OFF	When neutral position signal is entered.
Air conditioning switch signal	A/C Switch	ON or OFF	When air conditioning switch is turned ON.
Air conditioning relay signal	A/C Relay	ON or OFF	When air conditioning relay is in function.
Radiator main fan relay signal	Radiator Fan Relay #1	ON or OFF	When radiator main fan relay is in function.
Fuel pump relay signal	Fuel Pump Relay	ON or OFF	When fuel pump relay is in function.
Knocking signal	Knocking Signal	ON or OFF	When knocking signal is entered.
Radiator sub fan relay signal	Radiator Fan Relay #2	ON or OFF	When radiator sub fan relay is in function.
Engine torque control signal #1	Torque Control Signal #1	ON or OFF	When engine torque control signal 1 is entered.
Engine torque control signal #2	Torque Control Signal #2	ON or OFF	When engine torque control signal 2 is entered.
Engine torque control permission signal	Torque Control Permit	ON or OFF	When engine torque control permission signal is entered.
Front oxygen (A/F) sensor rich signal	Front O2 Rich Signal #1	ON or OFF	When front oxygen (A/F) sensor mixture ratio is rich.
Rear oxygen sensor rich signal	Rear O2 Rich Signal	ON or OFF	When rear oxygen sensor mixture ratio is rich.
Starter switch signal	Starter Switch Signal	ON or OFF	When starter switch signal is entered.
Idle switch signal	Idle Switch Signal	ON or OFF	When idle switch signal is entered.
Crankshaft position sensor signal	Crankshaft Position Sig.	ON or OFF	When crankshaft position sensor signal is entered.
Camshaft position sensor signal	Camshaft Position Sig.	ON or OFF	When camshaft position sensor signal is entered.

**NOTE:**

For detailed operation procedure, refer to the SUBARU SELECT MONITOR OPERATION MANUAL.

# SUBARU SELECT MONITOR

Engine (Diagnostics)

## 9. READ CURRENT DATA FOR AT. S058503A1609

- 1) On the «Main Menu» display screen, select the {Each System Check} and press the [YES] key.
  - 2) On the «System Selection Menu» display screen, select the {Transmission Control System} and press the [YES] key.
  - 3) Press the [YES] key after displayed the information of transmission type.
  - 4) On the «Transmission Diagnosis» display screen, select the {Current Data Display & Save} and press the [YES] key.
  - 5) On the «Data Display Menu» display screen, select the {Data Display} and press the [YES] key.
  - 6) Using the scroll key, move the display screen up or down until the desired data is shown.
- A list of the support data is shown in the following table.

Contents	Display	Unit of measure
Battery voltage	Battery Voltage	V
Rear vehicle speed sensor signal	Vehicle Speed #1	km/h or MPH
Front vehicle speed sensor signal	Vehicle Speed #2	km/h or MPH
Engine speed signal	Engine Speed	rpm
Automatic transmission fluid temperature signal	ATF Temp.	°C or °F
Throttle position signal	Throttle Sensor Voltage	V
Gear position	Gear Position	—
Line pressure control duty ratio	Line Pressure Duty Ratio	%
Lock up clutch control duty ratio	Lock Up Duty Ratio	%
Transfer clutch control duty ratio	Transfer Duty Ratio	%
Power supply for throttle position sensor	Throttle Sensor Power	V
Torque converter turbine speed signal	AT Turbine Speed	rpm
2-4 brake timing pressure control duty ratio	2-4B Duty Ratio	%
Intake manifold pressure sensor voltage	Mani. Pressure Voltage	V
2 wheel drive switch signal	2WD Switch	ON or OFF
Kick down switch signal	Kick Down Switch	ON or OFF
Stop lamp switch signal	Stop Lamp Switch	ON or OFF
Anti lock brake system signal	ABS Signal	ON or OFF
Cruise control system signal	Cruise Control Signal	ON or OFF
Neutral/Parking range signal	N/P Range Signal	ON or OFF
Reverse range signal	R Range Signal	ON or OFF
Drive range signal	D Range Signal	ON or OFF
3rd range signal	3rd Range Signal	ON or OFF
2nd range signal	2nd Range Signal	ON or OFF
1st range signal	1st Range Signal	ON or OFF
Shift control solenoid A	Shift Solenoid #1	ON or OFF
Shift control solenoid B	Shift Solenoid #2	ON or OFF
Torque control output signal #1	Torque Control Signal #1	ON or OFF
Torque control output signal #2	Torque Control Signal #2	ON or OFF
Torque control cut signal	Torque Control Cut Sig.	ON or OFF
2-4 brake timing control solenoid valve	2-4 Brake Timing Sol.	ON or OFF
Low clutch timing control solenoid valve	Low Clutch Timing Sol.	ON or OFF
Automatic transmission diagnosis indicator lamp	AT Diagnosis Lamp	ON or OFF

**NOTE:**

For detailed operation procedure, refer to the SUBARU SELECT MONITOR OPERATION MANUAL.



## 11. Read Diagnostic Trouble Code S058508

### A: OPERATION S058508A16

#### 1. SUBARU SELECT MONITOR (NORMAL MODE) S058508A1601

- 1) On the «Main Menu» display screen, select the {Each System Check} and press the [YES] key.
- 2) On the «System Selection Menu» display screen, select the {Engine Control System} and press the [YES] key.
- 3) Press the [YES] key after displayed the information of engine type.
- 4) On the «Engine Diagnosis» display screen, select the {Diagnostic Code(s) Display} and press the [YES] key.
- 5) On the «Diagnostic Code(s) Display» display screen, select the {Current Diagnostic Code(s)} or {History Diagnostic Code(s)} and press the [YES] key.

**NOTE:**

- For detailed operation procedure, refer to the SUBARU SELECT MONITOR OPERATION MANUAL.
- For detailed concerning diagnostic trouble codes, refer to the List of Diagnostic Trouble Code (DTC). <Ref. to EN(SOHC)-80, List of Diagnostic Trouble Code (DTC).>

#### 2. SUBARU SELECT MONITOR (OBD MODE) S058508A1602

- 1) On the «Main Menu» display screen, select the {2. Each System Check} and press the [YES] key.
- 2) On the «System Selection Menu» display screen, select the {Engine Control System} and press the [YES] key.
- 3) Press the [YES] key after displayed the information of engine type.
- 4) On the «Engine Diagnosis» display screen, select the {OBD System} and press the [YES] key.
- 5) On the «OBD Menu» display screen, select the {Diagnosis Code(s) Display} and press the [YES] key.
- 6) Make sure that a diagnostic trouble code (DTC) is shown on the display screen.

**NOTE:**

- For detailed operation procedure, refer to the SUBARU SELECT MONITOR OPERATION MANUAL.
- For detailed concerning diagnostic trouble codes, refer to the List of Diagnostic Trouble Code (DTC). <Ref. to EN(SOHC)-80, List of Diagnostic Trouble Code (DTC).>

### 3. OBD-II GENERAL SCAN TOOL S058508A1603

Refers to data denoting emission-related powertrain diagnostic trouble codes.

For details concerning diagnostic trouble codes, refer to the List of Diagnostic Trouble Code (DTC). <Ref. to EN(SOHC)-80, List of Diagnostic Trouble Code (DTC).>

**NOTE:**

Refer to OBD-II general scan tool manufacturer's instruction manual to access emission-related powertrain diagnostic trouble codes (MODE \$03).

## 12. Inspection Mode S058510

### A: OPERATION S058510A16

#### 1. PREPARATION FOR THE INSPECTION MODE S058510A1601

Raise the vehicle using a garage jack and place on safety stands or drive the vehicle onto free rollers.

**WARNING:**

- Before raising the vehicle, ensure parking brakes are applied.
- Do not use a pantograph jack in place of a safety stand.
- Secure a rope or wire to the front and rear towing or tie-down hooks to prevent the lateral runout of front wheels.
- Do not abruptly depress/release clutch pedal or accelerator pedal during works even when engine is operating at low speeds since this may cause vehicle to jump off free rollers.
- In order to prevent the vehicle from slipping due to vibration, do not place any wooden blocks or similar items between the safety stands and the vehicle.
- Since the rear wheels will also rotate, do not place anything near them. Also, make sure that nobody goes in front of the vehicle.

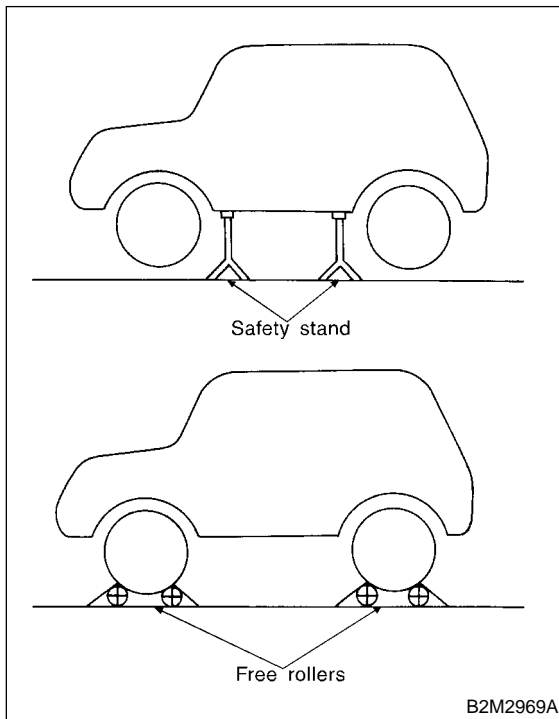

#### 2. SUBARU SELECT MONITOR S058510A1602

After performing diagnostics and clearing the memory, check for any remaining unresolved trouble data.

- 1) Prepare Subaru Select Monitor kit. <Ref. to EN(SOHC)-8, PREPARATION TOOL, General Description.>

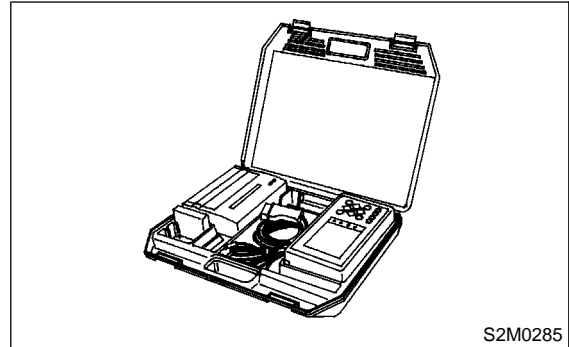

- 2) Connect diagnosis cable to Subaru Select Monitor.
- 3) Insert cartridge into Subaru Select Monitor. <Ref. to EN(SOHC)-8, PREPARATION TOOL, General Description.>

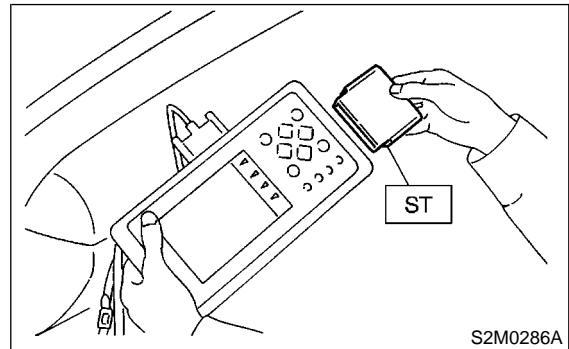

- 4) Connect test mode connector (A) at the lower portion of instrument panel (on the driver's side), to the side of the center console box.

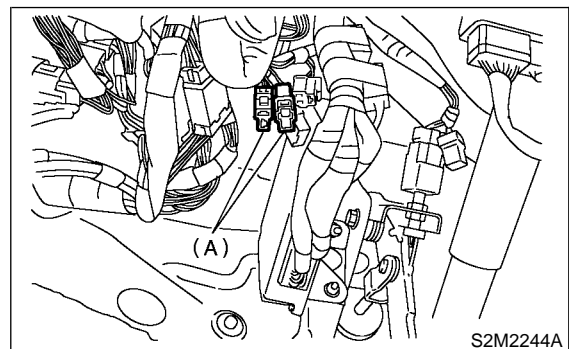

5) Connect Subaru Select Monitor to data link connector.

(1) Connect Subaru Select Monitor to data link connector located in the lower portion of the instrument panel (on the driver's side).

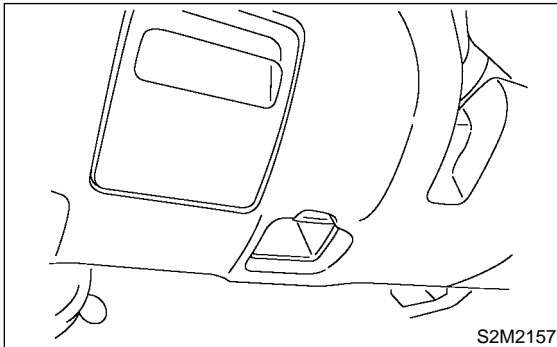

(2) Connect diagnosis cable to data link connector.

**CAUTION:**

**Do not connect scan tools except for Subaru Select Monitor and OBD-II general scan tool.**

6) Turn ignition switch to ON (engine OFF) and Subaru Select Monitor switch to ON.

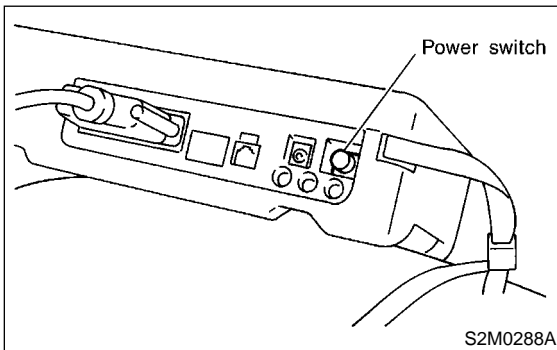

7) On the «Main Menu» display screen, select the {2. Each System Check} and press the [YES] key.

8) On the «System Selection Menu» display screen, select the {Engine Control System} and press the [YES] key.

9) Press the [YES] key after displayed the information of engine type.

10) On the «Engine Diagnosis» display screen, select the {Dealer Check Mode Procedure} and press the [YES] key.

11) When the "Perform Inspection (Dealer Check) Mode?" is shown on the display screen, press the [YES] key.

12) Perform subsequent procedures as instructed on the display screen.

- If trouble still remains in the memory, the corresponding diagnostic trouble code (DTC) appears on the display screen.

**NOTE:**

- For detailed operation procedure, refer to the SUBARU SELECT MONITOR OPERATION MANUAL.

- For detailed concerning diagnostic trouble codes, refer to the List of Diagnostic Trouble Code (DTC). <Ref. to EN(SOHC)-80, List of Diagnostic Trouble Code (DTC).>

- Release the parking brake.

- The speed difference between front and rear wheels may light either the ABS warning light, but this indicates no malfunctions. When engine control diagnosis is finished, perform the ABS memory clearance procedure of self-diagnosis system.

**3. OBD-II GENERAL SCAN TOOL** S058510A1603

After performing diagnostics and clearing the memory, check for any remaining unresolved trouble data:

1) Connect test mode connector (A) at the lower side of the instrument panel (on the driver's side), to the side of the center console box.

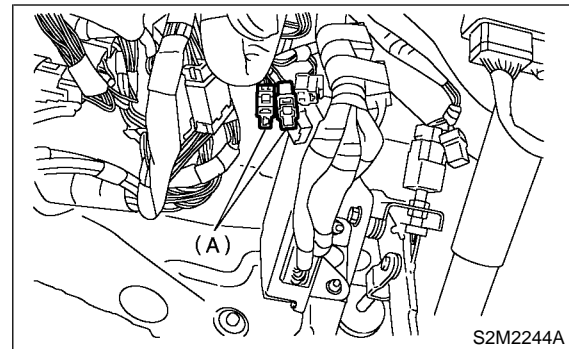

2) Connect the OBD-II general scan tool to its data link connector (A) in the lower portion of the instrument panel (on the driver's side).

**CAUTION:**

**Do not connect the scan tools except for Subaru Select Monitor and OBD-II general scan tool.**

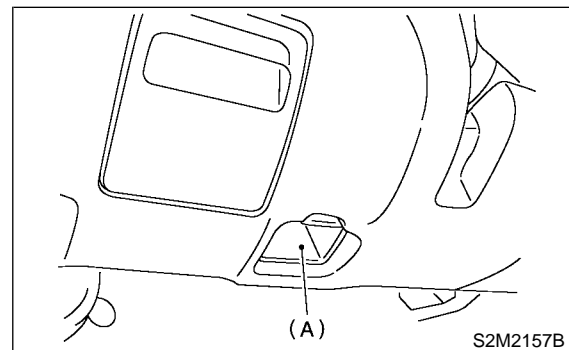

# INSPECTION MODE

## Engine (Diagnostics)

---

3) Start the engine.

**NOTE:**

- Ensure the selector lever is placed in the “P” position before starting. (AT vehicles)
- Depress clutch pedal when starting the engine. (MT vehicles)

4) Using the selector lever or shift lever, turn the “P” position switch and the “N” position switch to ON.

5) Depress the brake pedal to turn the brake switch ON. (AT vehicles)

6) Keep engine speed in the 2,500 — 3,000 rpm range for 40 seconds.

**NOTE:**

On models without tachometer, use the tachometer (Secondary pickup type).

7) Place the selector lever or shift lever in the “D” position (AT vehicles) or “1st” gear (MT vehicles) and drive the vehicle at 5 to 10 km/h (3 to 6 MPH).

**NOTE:**

- On AWD vehicles, release the parking brake.
- The speed difference between front and rear wheels may light the ABS warning light, but this indicates no malfunctions. When engine control diagnosis is finished, perform the ABS memory clearance procedure of self-diagnosis system.

8) Using the OBD-II general scan tool, check for diagnostic trouble code(s) and record the result(s).

**NOTE:**

- For detailed operation procedures, refer to the OBD-II General Scan Tool Instruction Manual.
- For detailed concerning diagnostic trouble codes, refer to the List of Diagnostic Trouble Code (DTC). <Ref. to EN(SOHC)-80, List of Diagnostic Trouble Code (DTC).>

## 13. Clear Memory Mode S058513

### A: OPERATION S058513A16

#### 1. SUBARU SELECT MONITOR (NORMAL MODE) S058513A1601

- 1) On the «Main Menu» display screen, select the {2. Each System Check} and press the [YES] key.
- 2) On the «System Selection Menu» display screen, select the {Engine Control System} and press the [YES] key.
- 3) Press the [YES] key after displayed the information of engine type.
- 4) On the «Engine Diagnosis» display screen, select the {Clear Memory} and press the [YES] key.
- 5) When the 'Done' and 'Turn Ignition Switch OFF' are shown on the display screen, turn the Subaru Select Monitor and ignition switch to OFF.

#### NOTE:

- After the memory has been cleared, the idle air control solenoid valve must be initialized. To do this, turn the ignition switch to the ON position. Wait 3 seconds before starting the engine.
- For detailed operation procedure, refer to the SUBARU SELECT MONITOR OPERATION MANUAL.

#### 2. SUBARU SELECT MONITOR (OBD MODE) S058513A1602

- 1) On the «Main Menu» display screen, select the {2. Each System Check} and press the [YES] key.
- 2) On the «System Selection Menu» display screen, select the {Engine Control System} and press the [YES] key.
- 3) Press the [YES] key after displayed the information of engine type.
- 4) On the «Engine Diagnosis» display screen, select the {OBD System} and press the [YES] key.
- 5) On the «OBD Menu» display screen, select the {4. Diagnosis Code(s) Cleared} and press the [YES] key.
- 6) When the 'Clear Diagnostic Code?' is shown on the display screen, press the [YES] key.
- 7) Turn Subaru Select Monitor and ignition switch to OFF.

#### NOTE:

- After the memory has been cleared, the idle air control solenoid valve must be initialized. To do this, turn the ignition switch to the ON position. Wait 3 seconds before starting the engine.
- For detailed operation procedure, refer to the SUBARU SELECT MONITOR OPERATION MANUAL.

### 3. OBD-II GENERAL SCAN TOOL S058513A1603

For clear memory procedures using the OBD-II general scan tool, refer to the OBD-II General Scan Tool Instruction Manual.

After the memory has been cleared, the idle air control solenoid valve must be initialized. To do this, turn the ignition switch to the ON position. Wait 3 seconds before starting the engine.

# COMPULSORY VALVE OPERATION CHECK MODE

Engine (Diagnostics)

## 14. Compulsory Valve Operation Check Mode

S058528

### A: OPERATION

S058528A16

1) Prepare Subaru Select Monitor kit. <Ref. to EN(SOHC)-8, PREPARATION TOOL, General Description.>

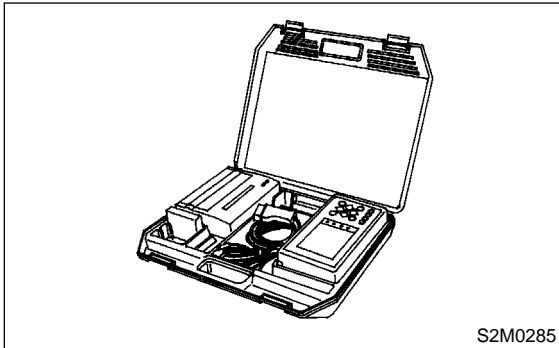

2) Connect diagnosis cable to Subaru Select Monitor.

3) Insert cartridge into Subaru Select Monitor. <Ref. to EN(SOHC)-8, PREPARATION TOOL, General Description.>

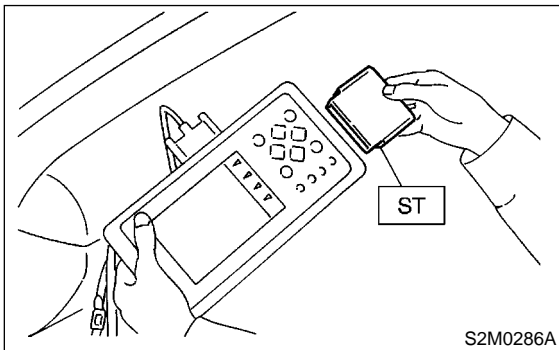

4) Connect test mode connector (A) at the lower portion of instrument panel (on the driver's side), to the side of the center console box.

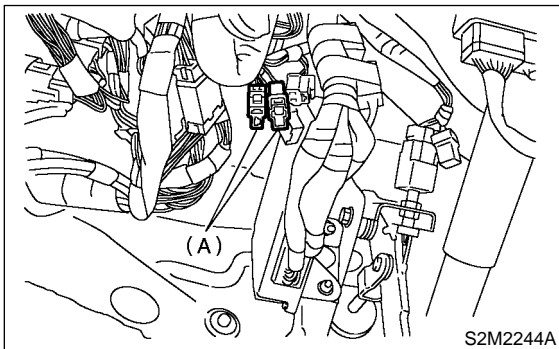

5) Connect Subaru Select Monitor to data link connector.

(1) Connect Subaru Select Monitor to data link connector located in the lower portion of the instrument panel (on the driver's side).

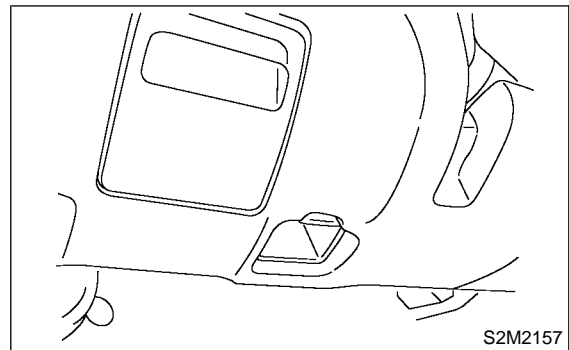

(2) Connect diagnosis cable to data link connector.

### CAUTION:

**Do not connect scan tools except for Subaru Select Monitor and OBD-II general scan tool.**

6) Turn ignition switch to ON (engine OFF) and Subaru Select Monitor switch to ON.

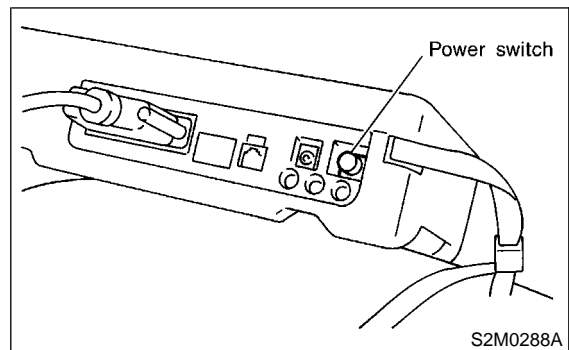

7) On the «Main Menu» display screen, select the {2. Each System Check} and press the [YES] key.

8) On the «System Selection Menu» display screen, select the {Engine Control System} and press the [YES] key.

9) Press the [YES] key after displayed the information of engine type.

10) On the «Engine Diagnosis» display screen, select the {System Operation Check Mode} and press the [YES] key.

11) On the «System Operation Check Mode» display screen, select the {Actuator ON/OFF Operation} and press the [YES] key.

12) Select the desired compulsory actuator on the «Actuator ON/OFF Operation» display screen and press the [YES] key.

13) Pressing the [NO] key completes the compulsory operation check mode. The display will then return to the «Actuator ON/OFF Operation» screen.

# COMPULSORY VALVE OPERATION CHECK MODE

Engine (Diagnostics)

- A list of the support data is shown in the following table.

Contents	Display
Compulsory fuel pump relay operation check	Fuel Pump Relay
Compulsory radiator fan relay operation check	Radiator Fan Relay
Compulsory air conditioning relay operation check	A/C Compressor Relay
Compulsory purge control solenoid valve operation check	CPC Solenoid Valve
Compulsory air assist injector solenoid valve operation check	AAI Solenoid Valve

## NOTE:

- The following parts will be displayed but not functional because they are not installed on the vehicle.

Display
EGR Solenoid Valve
ASV Solenoid Valve
PCV Solenoid Valve
Vent Control Solenoid Valve
FICD Solenoid
Pressure Switching Sol. 1
Pressure Switching Sol. 2
Fuel Tank Sensor Control Valve

- For detailed operation procedure, refer to the SUBARU SELECT MONITOR OPERATION MANUAL.

# ENGINE MALFUNCTION INDICATOR LAMP (MIL)

Engine (Diagnostics)

## 15. Engine Malfunction Indicator Lamp (MIL) S058653

### A: PROCEDURE S058653E45

1. Activation of check engine malfunction indicator lamp (MIL). <Ref. to EN(SOHC)-49, ACTIVATION OF CHECK ENGINE MALFUNCTION INDICATOR LAMP (MIL), Engine Malfunction Indicator Lamp (MIL).>
↓
2. Check engine malfunction indicator lamp (MIL) does not come on. <Ref. to EN(SOHC)-50, CHECK ENGINE MALFUNCTION INDICATOR LAMP (MIL) DOES NOT COME ON., Engine Malfunction Indicator Lamp (MIL).>
↓
3. Check engine malfunction indicator lamp (MIL) does not go off. <Ref. to EN(SOHC)-53, CHECK ENGINE MALFUNCTION INDICATOR LAMP (MIL) DOES NOT GO OFF., Engine Malfunction Indicator Lamp (MIL).>
↓
4. Check engine malfunction indicator lamp (MIL) does not blink at a cycle of 3 Hz. <Ref. to EN(SOHC)-54, CHECK ENGINE MALFUNCTION INDICATOR LAMP (MIL) DOES NOT BLINK AT A CYCLE OF 3 HZ., Engine Malfunction Indicator Lamp (MIL).>
↓
5. Check engine malfunction indicator lamp (MIL) remains blinking at a cycle of 3 Hz. <Ref. to EN(SOHC)-56, CHECK ENGINE MALFUNCTION INDICATOR LAMP (MIL) REMAINS BLINKING AT A CYCLE OF 3 HZ., Engine Malfunction Indicator Lamp (MIL).>



## B: ACTIVATION OF CHECK ENGINE MALFUNCTION INDICATOR LAMP (MIL)

S058653E89

1) When ignition switch is turned to ON (engine off), the CHECK ENGINE malfunction indicator lamp (MIL) in the combination meter illuminates.

### NOTE:

If the MIL does not illuminate, perform diagnostics of the CHECK ENGINE light circuit or the combination meter circuit. <Ref. to EN(SOHC)-50, CHECK ENGINE MALFUNCTION INDICATOR LAMP (MIL) DOES NOT COME ON., Engine Malfunction Indicator Lamp (MIL).>

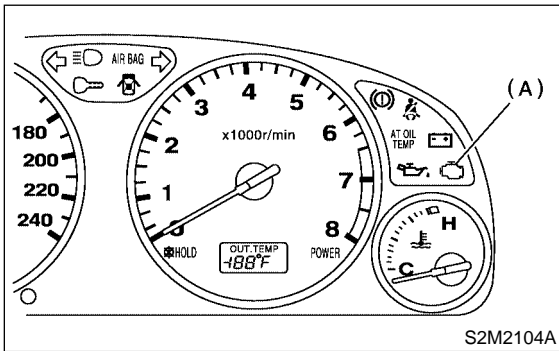

S2M2104A

(A) Malfunction indicator lamp (MIL)

2) After starting the engine, the MIL goes out. If it does not, either the engine or the emission control system is malfunctioning.

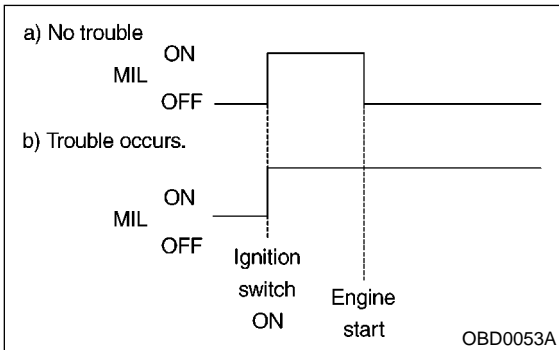

OBD0053A

3) If the diagnosis system senses a misfire which could damage the catalyzer, the MIL will blink at a cycle of 1 Hz.

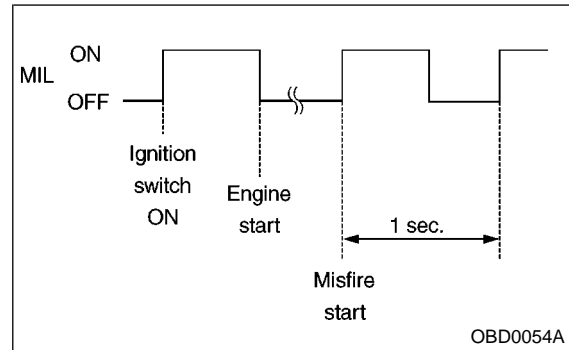

OBD0054A

4) When ignition switch is turned to ON (engine off) or to "START" with the test mode connector connected, the MIL blinks at a cycle of 3 Hz.

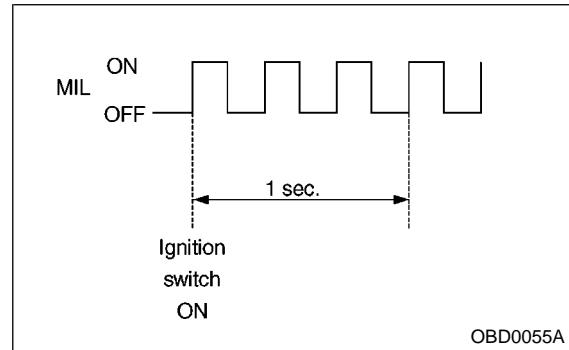

OBD0055A

# ENGINE MALFUNCTION INDICATOR LAMP (MIL)

Engine (Diagnostics)

## C: CHECK ENGINE MALFUNCTION INDICATOR LAMP (MIL) DOES NOT COME ON. S058653E90

- **DIAGNOSIS:**
  - The CHECK ENGINE malfunction indicator lamp (MIL) circuit is open or shorted.
- **TROUBLE SYMPTOM:**
  - When ignition switch is turned ON (engine OFF), MIL does not come on.
- **WIRING DIAGRAM:**

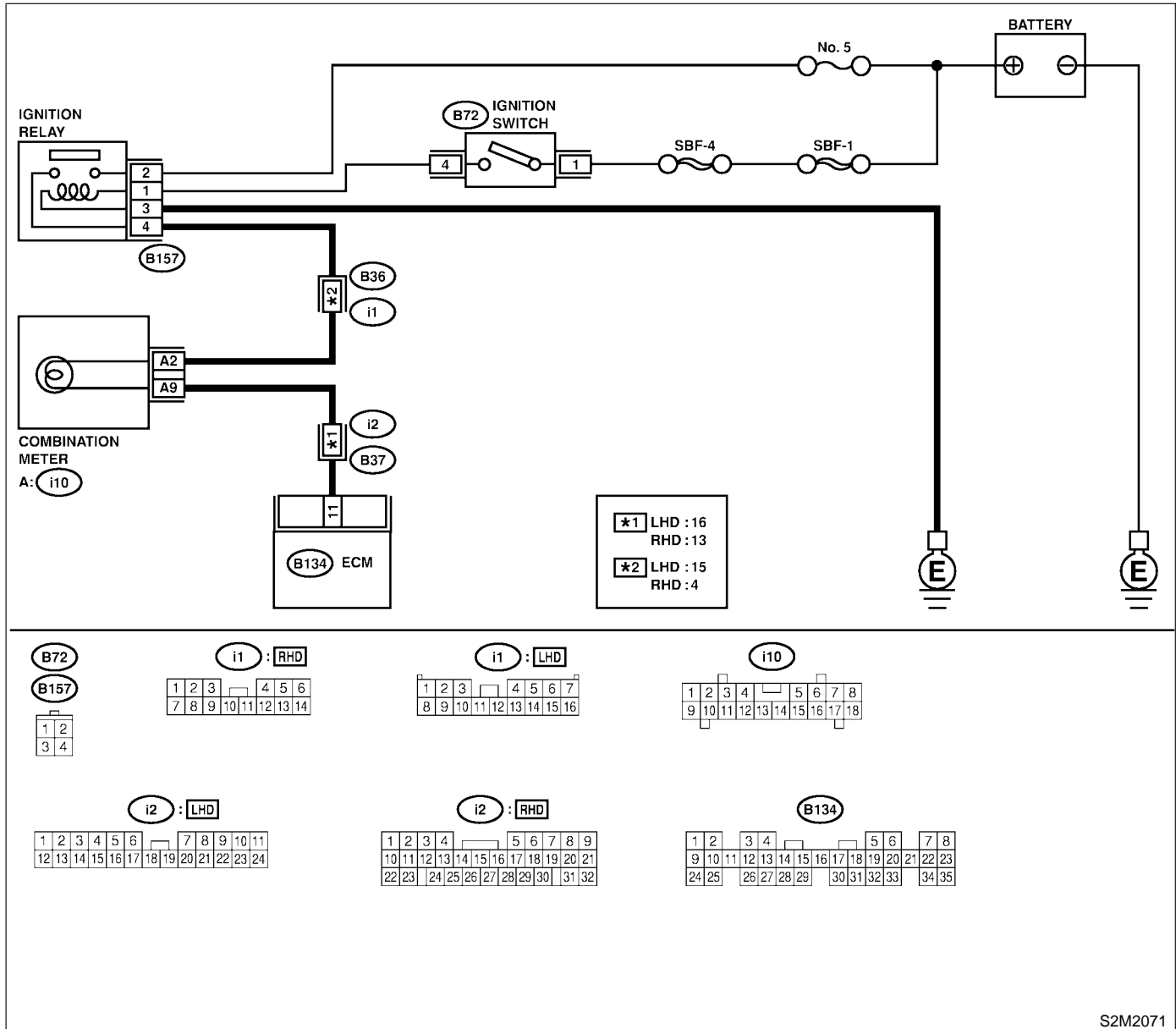

No.	Step	Check	Yes	No
1	<b>CHECK OUTPUT SIGNAL FROM ECM.</b> 1) Turn ignition switch to ON. 2) Measure voltage between ECM connector and chassis ground. <b>Connector &amp; terminal</b> <b>(B134) No. 11 (+) — Chassis ground (-):</b>	Is the voltage less than 1 V?	Go to step 4.	Go to step 2.

# ENGINE MALFUNCTION INDICATOR LAMP (MIL)

Engine (Diagnostics)

No.	Step	Check	Yes	No
2	<b>CHECK POOR CONTACT.</b>	Does the MIL come on when shaking or pulling ECM connector and harness?	Repair poor contact in ECM connector.	Go to step 3.
3	<b>CHECK ECM CONNECTOR.</b>	Is ECM connector correctly connected?	Replace ECM. <Ref. to FU(SOHC)-49, Engine Control Module.>	Repair connection of ECM connector.
4	<b>CHECK HARNESS BETWEEN COMBINATION METER AND ECM CONNECTOR.</b> 1) Turn ignition switch to OFF. 2) Remove combination meter. <Ref. to IDI-15, Combination Meter Assembly.> 3) Disconnect connector from ECM and combination meter. 4) Measure resistance of harness between ECM and combination meter connector. <b>Connector &amp; terminal</b> <b>(B134) No. 11 — (i10) No. 9:</b>	Is resistance less than 1 $\Omega$ ?	Go to step 5.	Repair harness and connector. NOTE: In this case, repair the following: <ul style="list-style-type: none"> <li>● Open circuit in harness between ECM and combination meter connector</li> <li>● Poor contact in coupling connector (i2)</li> </ul>
5	<b>CHECK POOR CONTACT.</b> Check poor contact in combination meter connector.	Is there poor contact in combination meter connector?	Repair poor contact in combination meter connector.	Go to step 6.
6	<b>CHECK HARNESS BETWEEN COMBINATION METER AND IGNITION SWITCH CONNECTOR.</b> 1) Turn ignition switch to ON. 2) Measure voltage between combination meter connector and chassis ground. <b>Connector &amp; terminal</b> <b>(i10) No. 2 (+) — Chassis ground (-):</b>	Is voltage more than 10 V?	Go to step 7.	Check the following and repair if necessary. NOTE: <ul style="list-style-type: none"> <li>● Broken down ignition relay.</li> <li>● Blown out fuse (No. 5).</li> <li>● If replaced fuse (No. 5) blows easily, check the harness for short circuit of harness between fuse (No. 5) and ignition relay connector.</li> <li>● Open or short circuit in harness between fuse (No. 5) and battery terminal</li> <li>● Open circuit in harness between fuse (No. 5) and ignition relay connector</li> <li>● Poor contact in ignition relay connector</li> <li>● Poor contact in ignition switch connector</li> </ul>

# ENGINE MALFUNCTION INDICATOR LAMP (MIL)

Engine (Diagnostics)

No.	Step	Check	Yes	No
7	<b>CHECK LAMP BULB.</b> Remove engine malfunction indicator lamp bulb.	Is lamp bulb condition OK?	Repair combination meter connector.	Replace lamp bulb.

# ENGINE MALFUNCTION INDICATOR LAMP (MIL)

Engine (Diagnostics)

## D: CHECK ENGINE MALFUNCTION INDICATOR LAMP (MIL) DOES NOT GO OFF.

S058653E91

### ● DIAGNOSIS:

- The CHECK ENGINE malfunction indicator lamp (MIL) circuit is shorted.

### ● TROUBLE SYMPTOM:

- Although MIL comes on when engine runs, trouble code is not shown on Subaru select monitor or OBD-II general scan tool display.

### ● WIRING DIAGRAM:

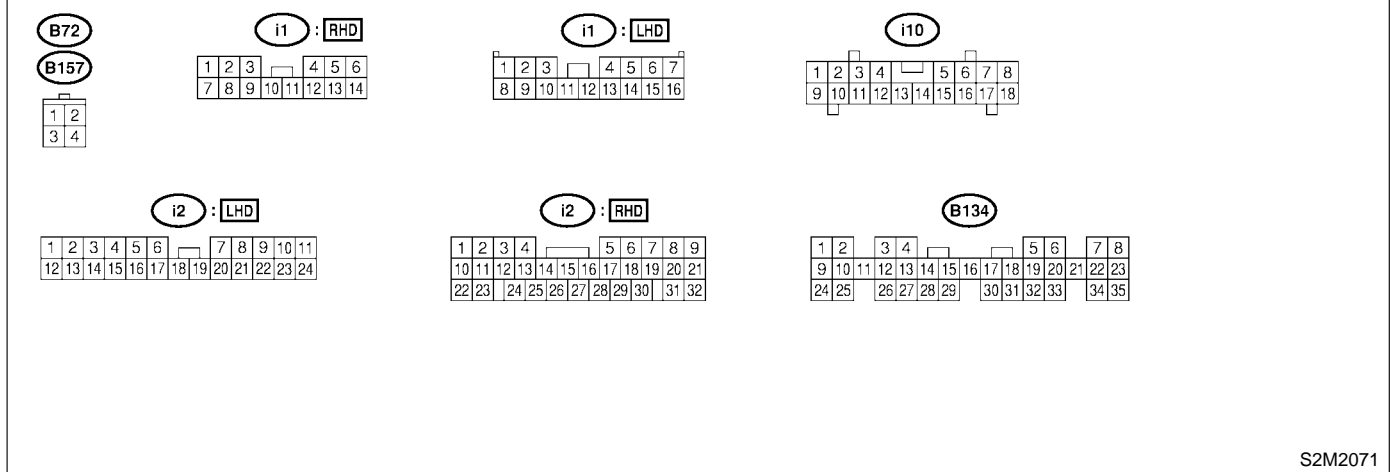
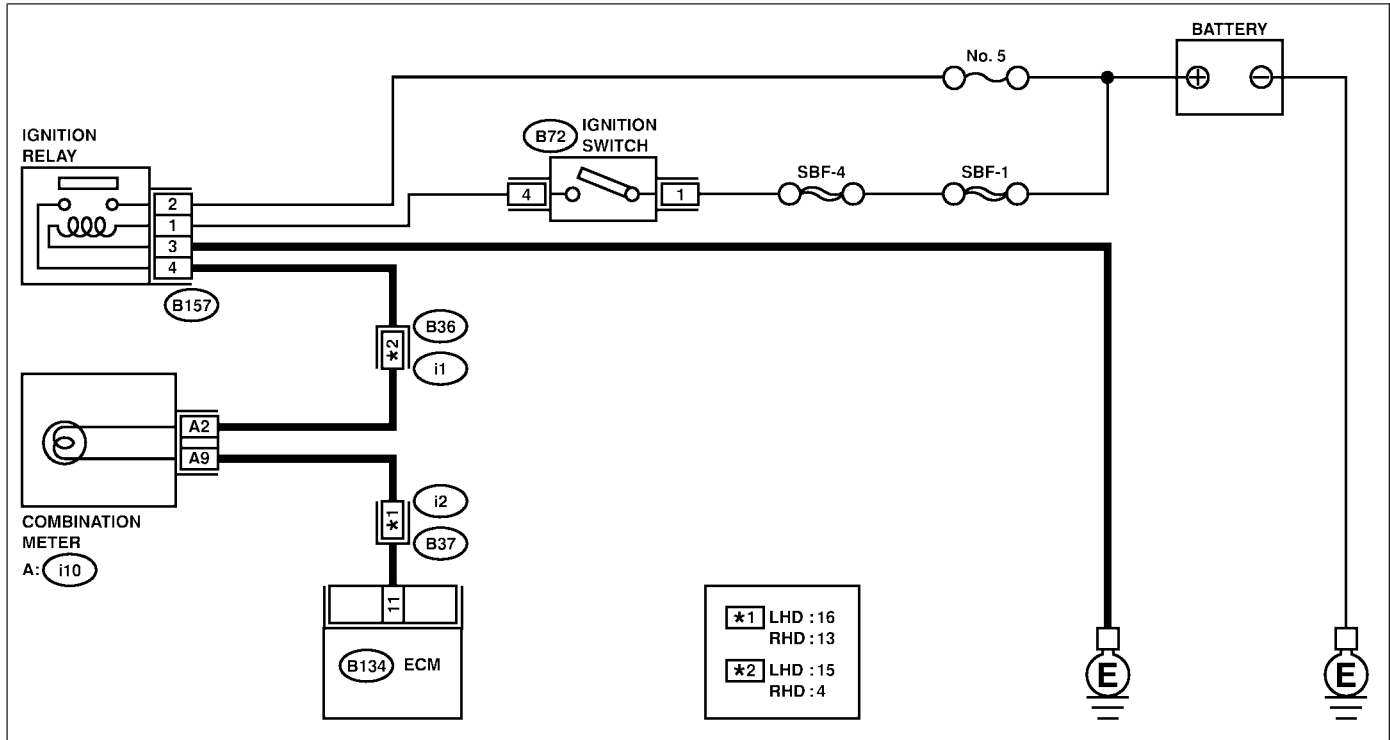

S2M2071

No.	Step	Check	Yes	No
1	<b>CHECK HARNESS BETWEEN COMBINATION METER AND ECM CONNECTOR.</b> 1) Turn ignition switch to OFF. 2) Disconnect connector from ECM. 3) Turn ignition switch to ON.	Does the MIL come on?	Repair short circuit in harness between combination meter and ECM connector.	Replace ECM. <Ref. to FU(SOHC)-49, Engine Control Module.>

# ENGINE MALFUNCTION INDICATOR LAMP (MIL)

Engine (Diagnostics)

## E: CHECK ENGINE MALFUNCTION INDICATOR LAMP (MIL) DOES NOT BLINK AT A CYCLE OF 3 Hz. S058653E92

- **DIAGNOSIS:**
  - The CHECK ENGINE malfunction indicator lamp (MIL) circuit is open or shorted.
  - Test mode connector circuit is in open.
- **TROUBLE SYMPTOM:**
  - When inspection mode, MIL does not blink at a cycle of 3 Hz.
- **WIRING DIAGRAM:**

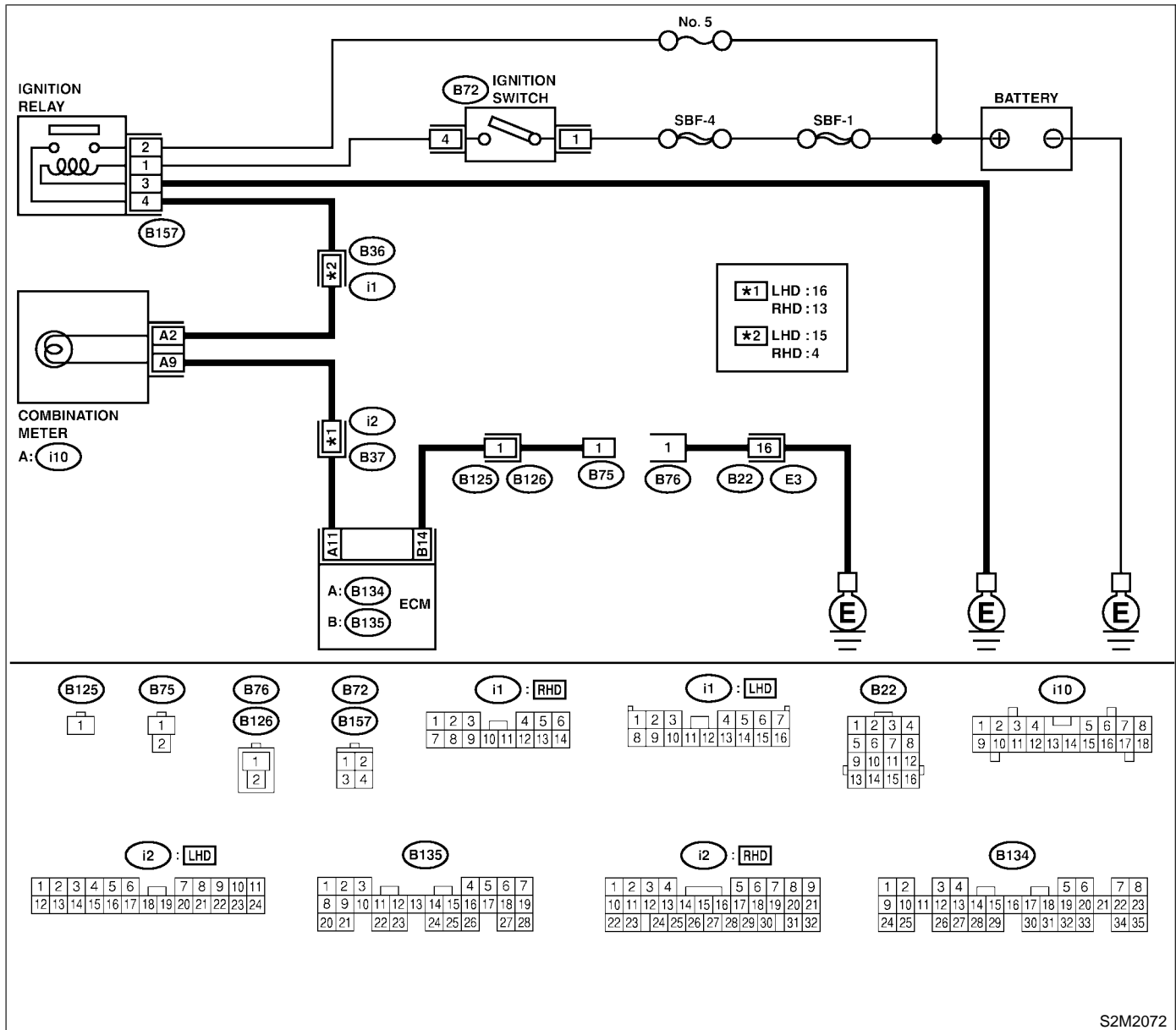

S2M2072

# ENGINE MALFUNCTION INDICATOR LAMP (MIL)

Engine (Diagnostics)

No.	Step	Check	Yes	No
1	<b>CHECK STATUS OF CHECK ENGINE MALFUNCTION INDICATOR LAMP (MIL).</b> 1) Turn ignition switch to OFF. 2) Disconnect test mode connector. 3) Turn ignition switch to ON. (engine OFF)	Does the MIL come on?	Go to step 2.	Repair the MIL circuit. <Ref. to EN(SOHC)-50, CHECK ENGINE MALFUNCTION INDICATOR LAMP (MIL) DOES NOT COME ON., Engine Malfunction Indicator Lamp (MIL).>
2	<b>CHECK HARNESS BETWEEN COMBINATION METER AND ECM CONNECTOR.</b> 1) Turn ignition switch to OFF. 2) Disconnect connector from ECM. 3) Turn ignition switch to ON.	Does the MIL come on?	Repair ground short circuit in harness between combination meter and ECM connector.	Go to step 3.
3	<b>CHECK HARNESS BETWEEN TEST MODE CONNECTOR AND CHASSIS GROUND.</b> 1) Turn ignition switch to OFF. 2) Disconnect connector from ECM. 3) Measure resistance of harness between test mode connector and chassis ground. <i><b>Connector &amp; terminal</b></i> <i><b>(B76) No. 1 — Chassis ground:</b></i>	Is resistance less than 1 $\Omega$ ?	Go to step 4.	Repair harness and connector. NOTE: In this case, repair the following: <ul style="list-style-type: none"> <li>● Open circuit in harness between test mode connector and chassis ground</li> </ul>
4	<b>CHECK POOR CONTACT.</b> Check poor contact in ECM connector.	Is there poor contact in ECM connector?	Repair poor contact in ECM connector.	Go to step 5.
5	<b>CHECK HARNESS BETWEEN ECM AND TEST MODE CONNECTOR.</b> 1) Connect test mode connector. 2) Measure resistance of harness between ECM and chassis ground. <i><b>Connector &amp; terminal</b></i> <i><b>(B135) No. 14 — Chassis ground:</b></i>	Is resistance less than 1 $\Omega$ ?	Go to step 6.	Repair open circuit in harness between ECM and test mode connector.
6	<b>CHECK POOR CONTACT.</b> Check poor contact in ECM connector.	Is there poor contact in ECM connector?	Repair poor contact in ECM connector.	Replace ECM. <Ref. to FU(SOHC)-49, Engine Control Module.>

# ENGINE MALFUNCTION INDICATOR LAMP (MIL)

Engine (Diagnostics)

## F: CHECK ENGINE MALFUNCTION INDICATOR LAMP (MIL) REMAINS BLINKING AT A CYCLE OF 3 Hz. S058653E93

- **DIAGNOSIS:**
  - Test mode connector circuit is shorted.
- **TROUBLE SYMPTOM:**
  - MIL blinks at a cycle of 3 Hz when ignition switch is turned to ON.
- **WIRING DIAGRAM:**

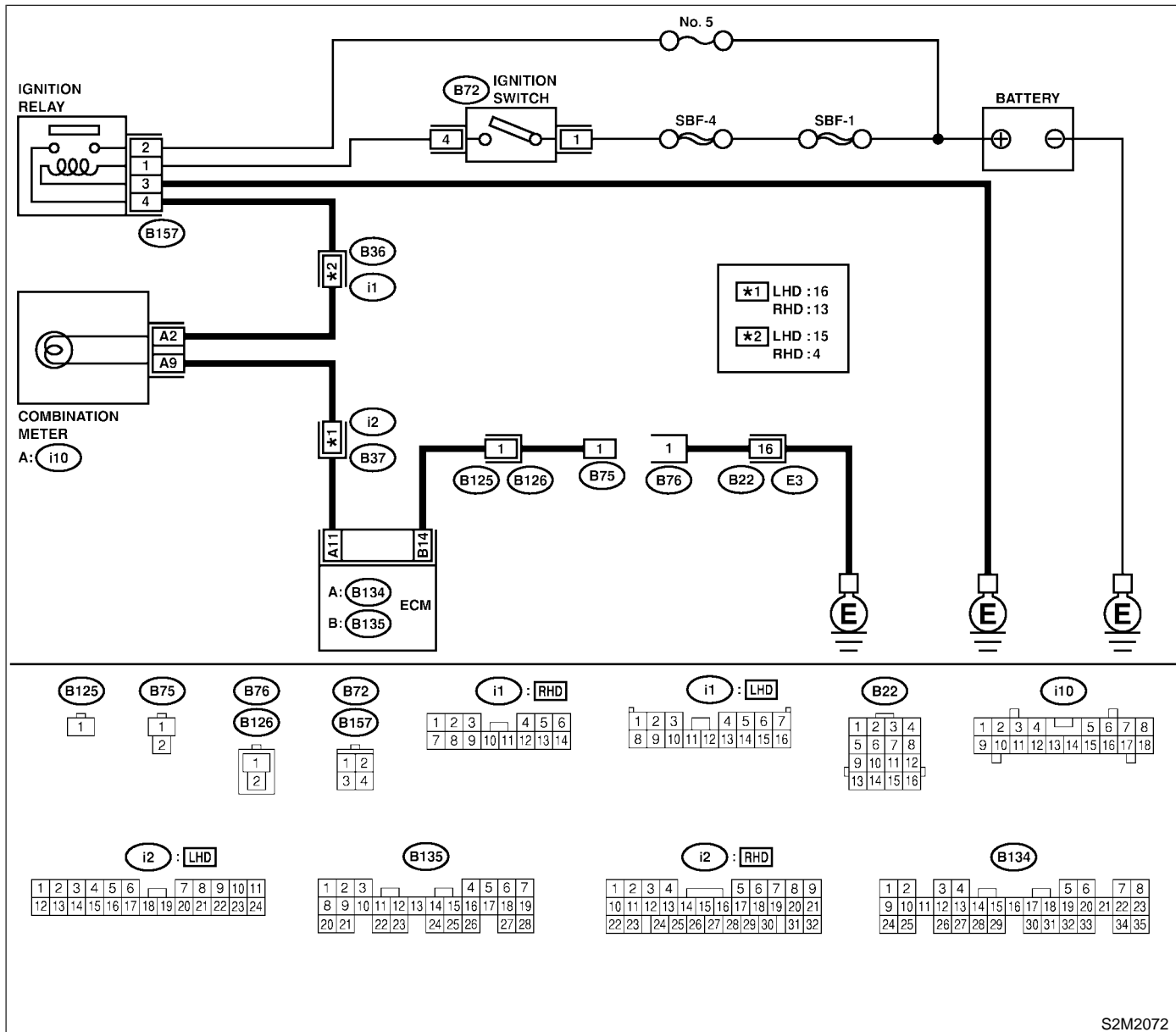

S2M2072

No.	Step	Check	Yes	No
1	<b>CHECK TEST MODE CONNECTOR.</b> 1) Disconnect test mode connector. 2) Turn ignition switch to ON.	Does MIL flash on and off?	Go to step 2.	System is in good order. NOTE: MIL blinks at a cycle of 3 Hz when test mode connector is connected.



# ENGINE MALFUNCTION INDICATOR LAMP (MIL)

Engine (Diagnostics)

No.	Step	Check	Yes	No
2	<b>CHECK HARNESS BETWEEN ECM CONNECTOR AND ENGINE GROUNDING TERMINAL.</b> 1) Turn ignition switch to OFF. 2) Disconnect connector from ECM. 3) Measure resistance of harness between ECM connector and chassis ground. <b>Connector &amp; terminal</b> <b>(B135) No. 14 — Chassis ground:</b>	Is resistance less than 5 $\Omega$ ?	Repair short circuit in harness between ECM and test mode connector.	Replace ECM. <Ref. to FU(SOHC)-49, Engine Control Module.>

# ENGINE MALFUNCTION INDICATOR LAMP (MIL)

Engine (Diagnostics)

---

**MEMO:**

## 16. Diagnostics for Engine Starting Failure S058533

### A: PROCEDURE S058533E45

1. Inspection of starter motor circuit. <Ref. to EN(SOHC)-60, STARTER MOTOR CIRCUIT, Diagnostics for Engine Starting Failure.>
↓
2. Inspection of ECM power supply and ground line. <Ref. to EN(SOHC)-64, CONTROL MODULE POWER SUPPLY AND GROUND LINE, Diagnostics for Engine Starting Failure.>
↓
3. Inspection of ignition control system. <Ref. to EN(SOHC)-68, IGNITION CONTROL SYSTEM, Diagnostics for Engine Starting Failure.>
↓
4. Inspection of fuel pump circuit. <Ref. to EN(SOHC)-72, FUEL PUMP CIRCUIT, Diagnostics for Engine Starting Failure.>
↓
5. Inspection of fuel injector circuit. <Ref. to EN(SOHC)-76, FUEL INJECTOR CIRCUIT, Diagnostics for Engine Starting Failure.>

# DIAGNOSTICS FOR ENGINE STARTING FAILURE

Engine (Diagnostics)

## B: STARTER MOTOR CIRCUIT S058533E94

### CAUTION:

After repair or replacement of faulty parts, conduct CLEAR MEMORY MODE <Ref. to EN(SOHC)-45, Clear Memory Mode.> and INSPECTION MODE <Ref. to EN(SOHC)-42, Inspection Mode.>

### ● WIRING DIAGRAM:

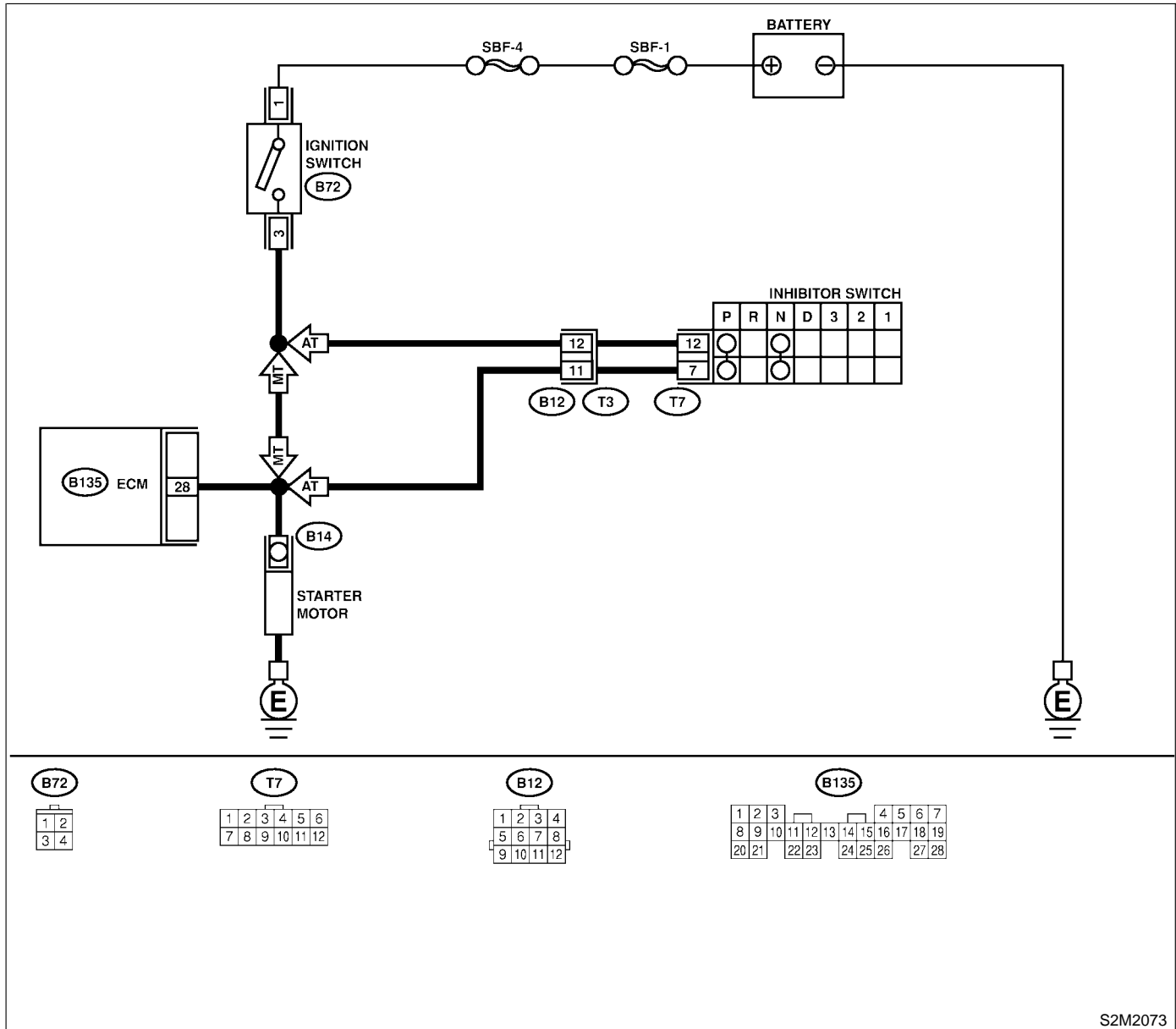

S2M2073

# DIAGNOSTICS FOR ENGINE STARTING FAILURE

Engine (Diagnostics)

No.	Step	Check	Yes	No
1	<b>CHECK OPERATION OF STARTER MOTOR.</b>	Does starter motor operate when the switch starts?	Go to step 2.	Go to step 3.
2	<b>CHECK DTC.</b> <Ref. to EN(SOHC)-41, OPERATION, Read Diagnostic Trouble Code.>	Is the trouble code stored in memory? <Ref. to EN(SOHC)-80, LIST, List of Diagnostic Trouble Code (DTC).>	Record DTC. Repair the trouble case. <Ref. to EN(SOHC)-86, Engine Control Module (ECM) I/O Signal.>	Go to step 3.
3	<b>CHECK INPUT SIGNAL FOR STARTER MOTOR.</b> 1) Turn ignition switch to OFF. 2) Disconnect connector from starter motor. 3) Turn ignition switch to ST. 4) Measure power supply voltage between starter motor connector terminal and engine ground. <b>Connector &amp; terminal</b> <b>(B14) No. 1 (+) — Engine ground (-):</b> NOTE: On AT vehicles, place the selector lever in the "P" or "N" position.	Is the voltage more than 10 V?	Go to step 4.	Go to step 5.
4	<b>CHECK GROUND CIRCUIT OF STARTER MOTOR.</b> 1) Turn ignition switch to OFF. 2) Disconnect terminal from starter motor. 3) Measure resistance of ground cable between ground cable terminal and engine ground.	Is resistance less than 5 $\Omega$ ?	Check starter motor. <Ref. to SC-5, Starter.>	Repair open circuit of ground cable.
5	<b>CHECK HARNESS BETWEEN ECM AND STARTER MOTOR CIRCUIT.</b> 1) Turn ignition switch to OFF. 2) Measure resistance between starter motor and ECM. <b>Connector &amp; terminal</b> <b>(B14) No. 1 — Engine ground:</b>	Is resistance less than 1 $\Omega$ ?	Repair ground short circuit.	Go to step 6.
6	<b>CHECK HARNESS BETWEEN ECM AND STARTER MOTOR CIRCUIT.</b> 1) Turn ignition switch to START. 2) Measure resistance of fuse. <b>Connector &amp; terminal</b> <b>(B14) No. 1 — Engine ground:</b>	Is resistance less than 1 $\Omega$ ?	Go to step 7.	Repair ground short circuit.
7	<b>CHECK HARNESS BETWEEN BATTERY AND IGNITION SWITCH CONNECTOR.</b> 1) Ignition switch to OFF. 2) Disconnect connector from ignition switch. 3) Measure power supply voltage between ignition switch connector and chassis ground. <b>Connector &amp; terminal</b> <b>(B72) No. 1 (+) — Chassis ground (-):</b>	Is the voltage more than 10 V?	Go to step 8.	Repair open circuit in harness between ignition switch and battery.
8	<b>CHECK HARNESS BETWEEN BATTERY AND IGNITION SWITCH CONNECTOR.</b> 1) Connect connector to ignition switch. 2) Turn ignition switch to START. 3) Measure voltage between ignition switch and chassis ground. <b>Connector &amp; terminal</b> <b>(B72) No. 3 (+) — Chassis ground (-):</b>	Is the voltage more than 10 V?	Go to step 9.	Replace ignition switch.

# DIAGNOSTICS FOR ENGINE STARTING FAILURE

Engine (Diagnostics)

No.	Step	Check	Yes	No
9	<b>CHECK TRANSMISSION TYPE.</b>	Is the vehicle AT?	Go to step 10.	Repair open circuit between ignition switch and starter motor circuit.
10	<b>CHECK INHIBITOR SWITCH CIRCUIT.</b> 1) Turn ignition switch to OFF. 2) Place the selector lever in the "P" or "N" position. 3) Separate transmission harness connector. 4) Measure resistance between transmission harness connector receptacle's terminals. <b>Connector &amp; terminal</b> <b>(T3) No. 11 — No. 12:</b>	Is the resistance less than 1 Ω?	Repair open circuit in harness between starter motor and ignition switch connector.	Go to step 11.
11	<b>CHECK TRANSMISSION HARNESS.</b> 1) Disconnect connector from inhibitor switch. 2) Measure resistance of harness between transmission harness and inhibitor switch connector. <b>Connector &amp; terminal</b> <b>(T3) No. 11 — (T7) No. 7:</b>	Is the resistance less than 1 Ω?	Go to step 12.	Repair open circuit in harness between transmission harness and inhibitor switch connector.
12	<b>CHECK POOR CONTACT.</b> Check poor contact in inhibitor switch connector.	Is there poor contact in inhibitor switch connector?	Repair poor contact in inhibitor switch connector.	Replace inhibitor switch.

# DIAGNOSTICS FOR ENGINE STARTING FAILURE

Engine (Diagnostics)

---

**MEMO:**

# DIAGNOSTICS FOR ENGINE STARTING FAILURE

Engine (Diagnostics)

## C: CONTROL MODULE POWER SUPPLY AND GROUND LINE

S058533E37

### CAUTION:

After repair or replacement of faulty parts, conduct CLEAR MEMORY MODE <Ref. to EN(SOHC)-45, Clear Memory Mode.> and INSPECTION MODE. <Ref. to EN(SOHC)-42, Inspection Mode.>

### ● WIRING DIAGRAM:

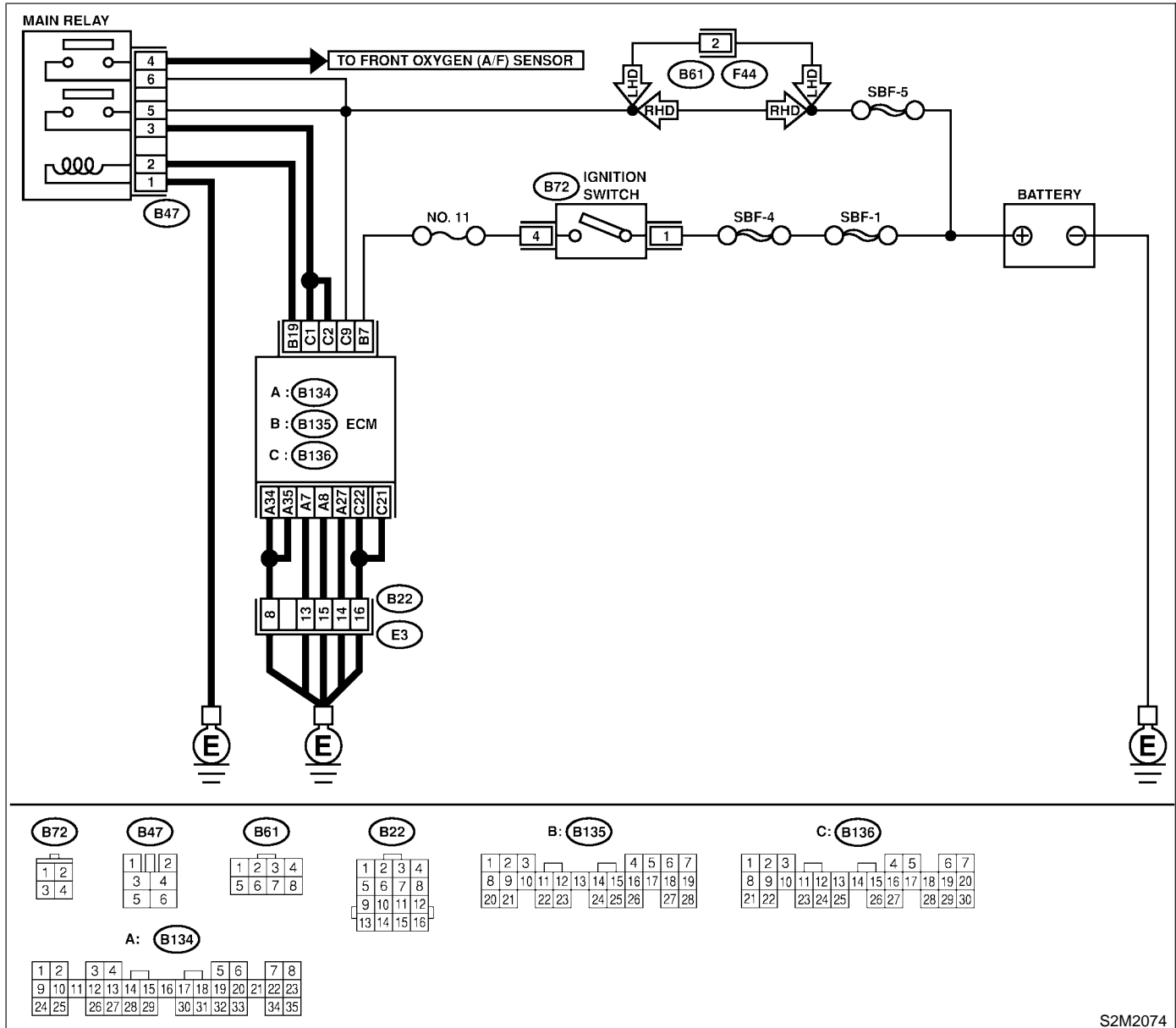

S2M2074

No.	Step	Check	Yes	No
1	<b>CHECK MAIN RELAY.</b> 1) Turn the ignition switch to OFF. 2) Remove main relay. 3) Connect battery to main relay terminals No. 1 and No. 2. 4) Measure resistance between main relay terminals. <b>Terminals</b> No. 3 — No. 5: No. 4 — No. 6:	Is the resistance less than 10 Ω?	Go to step 2.	Replace main relay.



# DIAGNOSTICS FOR ENGINE STARTING FAILURE

Engine (Diagnostics)

No.	Step	Check	Yes	No
2	<b>CHECK GROUND CIRCUIT OF ECM.</b> 1) Disconnect connector from ECM. 2) Measure resistance of harness between ECM and chassis ground. <b>Connector &amp; terminal</b> <i>(B136) No. 21 — Chassis ground:</i> <i>(B136) No. 22 — Chassis ground:</i> <i>(B134) No. 27 — Chassis ground:</i> <i>(B134) No. 8 — Chassis ground:</i> <i>(B134) No. 7 — Chassis ground:</i> <i>(B134) No. 34 — Chassis ground:</i> <i>(B134) No. 35 — Chassis ground:</i>	Is the resistance less than 5 $\Omega$ ?	Go to step 3.	Repair open circuit in harness between ECM connector and engine grounding terminal.
3	<b>CHECK INPUT VOLTAGE OF ECM.</b> Measure voltage between ECM connector and chassis ground. <b>Connector &amp; terminal</b> <i>(B136) No. 9 (+) — Chassis ground (-):</i>	Is the voltage more than 10 V?	Go to step 4.	Repair open or ground short circuit of power supply circuit.
4	<b>CHECK INPUT VOLTAGE OF ECM.</b> 1) Turn ignition switch to ON. 2) Measure voltage between ECM connector and chassis ground. <b>Connector &amp; terminal</b> <i>(B135) No. 7 (+) — Chassis ground (-):</i>	Is the voltage more than 10 V?	Go to step 5.	Repair open or ground short circuit of power supply circuit.
5	<b>CHECK HARNESS BETWEEN ECM AND MAIN RELAY CONNECTOR.</b> 1) Turn ignition switch to OFF. 2) Measure resistance between ECM and chassis ground. <b>Connector &amp; terminal</b> <i>(B135) No. 19 — Chassis ground:</i>	Is the resistance more than 1 M $\Omega$ ?	Go to step 6.	Repair ground short circuit in harness between ECM connector and main relay connector, then replace ECM.
6	<b>CHECK OUTPUT VOLTAGE FROM ECM.</b> 1) Connect connector to ECM. 2) Turn ignition switch to ON. 3) Measure voltage between ECM connector and chassis ground. <b>Connector &amp; terminal</b> <i>(B135) No. 19 (+) — Chassis ground (-):</i>	Is the voltage more than 10 V?	Go to step 7.	Replace ECM.
7	<b>CHECK INPUT VOLTAGE OF MAIN RELAY.</b> Check voltage between main relay connector and chassis ground. <b>Connector &amp; terminal</b> <i>(B47) No. 2 (+) — Chassis ground (-):</i>	Is the voltage more than 10 V?	Go to step 8.	Repair open circuit in harness between ECM connector and main relay connector.
8	<b>CHECK GROUND CIRCUIT OF MAIN RELAY.</b> 1) Turn ignition switch to OFF. 2) Measure resistance between main relay connector and chassis ground. <b>Connector &amp; terminal</b> <i>(B47) No. 1 — Chassis ground:</i>	Is the resistance less than 5 $\Omega$ ?	Go to step 9.	Repair open circuit between main relay and chassis ground.
9	<b>CHECK INPUT VOLTAGE OF MAIN RELAY.</b> Measure voltage between main relay connector and chassis ground. <b>Connector &amp; terminal</b> <i>(B47) No. 5 (+) — Chassis ground (-):</i> <i>(B47) No. 6 (+) — Chassis ground (-):</i>	Is the voltage more than 10 V?	Go to step 10.	Repair open or ground short circuit in harness of power supply circuit.

# DIAGNOSTICS FOR ENGINE STARTING FAILURE

Engine (Diagnostics)

No.	Step	Check	Yes	No
10	<b>CHECK INPUT VOLTAGE OF ECM.</b> 1) Connect main relay connector. 2) Turn ignition switch to ON. 3) Measure voltage between ECM connector and chassis ground. <b>Connector &amp; terminal</b> <b>(B136) No. 1 (+) — Chassis ground (-):</b> <b>(B136) No. 2 (+) — Chassis ground (-):</b>	Is the voltage more than 10 V?	Check ignition control system. <Ref. to EN(SOHC)-68, IGNITION CONTROL SYSTEM, Diagnostics for Engine Starting Failure.>	Repair open or ground short circuit in harness between ECM connector and main relay connector.

# DIAGNOSTICS FOR ENGINE STARTING FAILURE

Engine (Diagnostics)

---

**MEMO:**

# DIAGNOSTICS FOR ENGINE STARTING FAILURE

Engine (Diagnostics)

## D: IGNITION CONTROL SYSTEM

S058533E95

### CAUTION:

After repair or replacement of faulty parts, conduct CLEAR MEMORY MODE <Ref. to EN(SOHC)-45, Clear Memory Mode.> and INSPECTION MODE <Ref. to EN(SOHC)-42, Inspection Mode.>

### ● WIRING DIAGRAM:

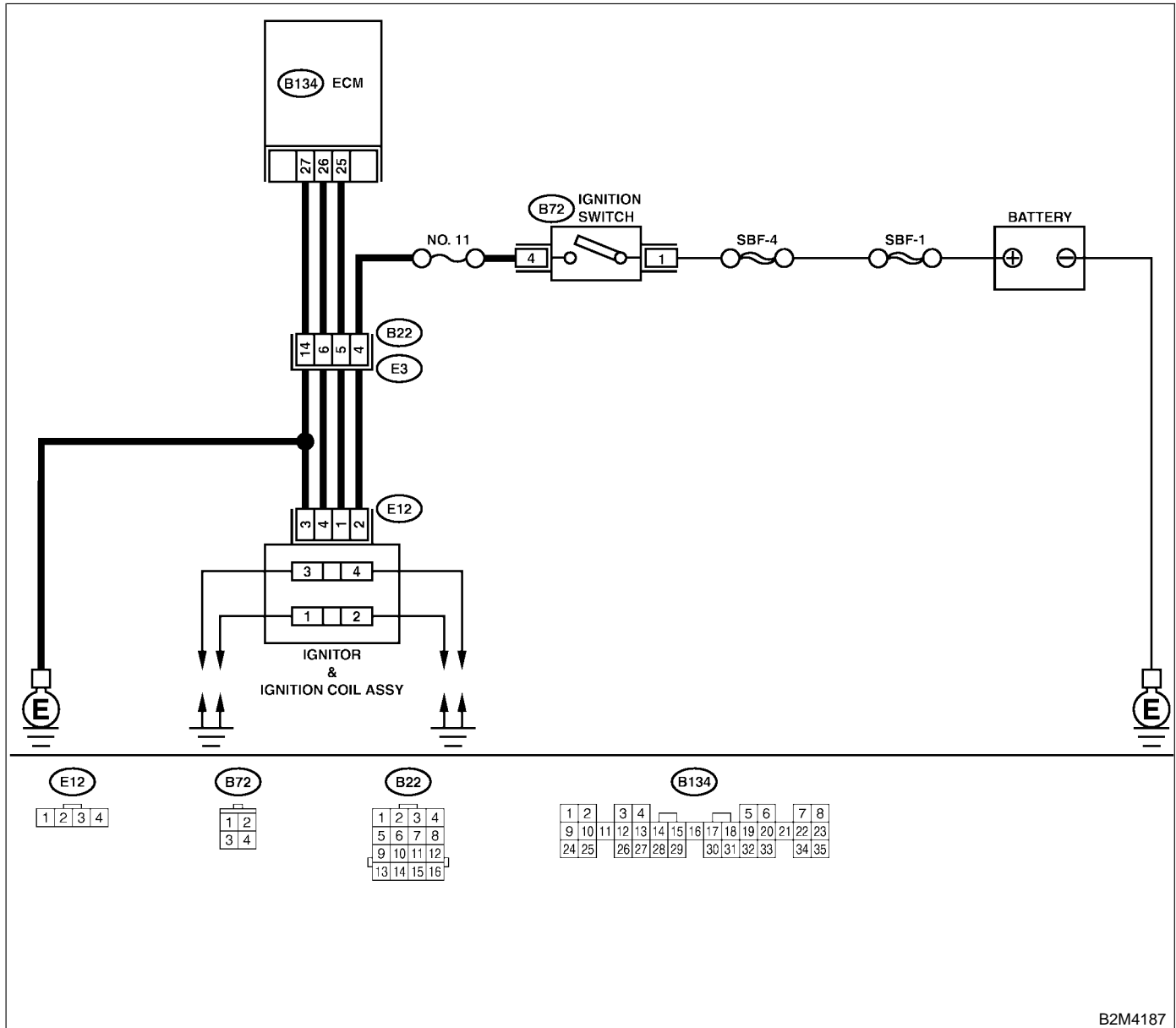

B2M4187

# DIAGNOSTICS FOR ENGINE STARTING FAILURE

Engine (Diagnostics)

No.	Step	Check	Yes	No
1	<p><b>CHECK IGNITION SYSTEM FOR SPARKS.</b>                      1) Remove plug cord cap from each spark plug.                      2) Install new spark plug on plug cord cap.  <b>CAUTION:</b>  <b>Do not remove spark plug from engine.</b>                      3) Contact spark plug's thread portion on engine.                      4) While opening throttle valve fully, crank engine to check that spark occurs at each cylinder.</p>	Does spark occur at each cylinder?	Check fuel pump system. <Ref. to EN(SOHC)-72, FUEL PUMP CIRCUIT, Diagnostics for Engine Starting Failure.>	Go to step 2.
2	<p><b>CHECK POWER SUPPLY CIRCUIT FOR IGNITION COIL &amp; IGNITOR ASSEMBLY.</b>                      1) Turn ignition switch to OFF.                      2) Disconnect connector from ignition coil &amp; ignitor assembly.                      3) Turn ignition switch to ON.                      4) Measure power supply voltage between ignition coil &amp; ignitor assembly connector and engine ground.  <b>Connector &amp; terminal</b>  <b>(E12) No. 2 (+) — Engine ground (-):</b></p>	Is the voltage more than 10 V?	Go to step 3.	Repair harness and connector. <b>NOTE:</b> In this case, repair the following: <ul style="list-style-type: none"> <li>● Open circuit in harness between ignition coil &amp; ignitor assembly, and ignition switch connector</li> <li>● Poor contact in coupling connectors (B22)</li> </ul>
3	<p><b>CHECK HARNESS OF IGNITION COIL &amp; IGNITOR ASSEMBLY GROUND CIRCUIT.</b>                      1) Turn ignition switch to OFF.                      2) Measure resistance between ignition coil &amp; ignitor assembly connector and engine ground.  <b>Connector &amp; terminal</b>  <b>(E12) No. 3 — Engine ground:</b></p>	Is the resistance between less than 5 $\Omega$ ?	Go to step 4.	Repair harness and connector. <b>NOTE:</b> In this case, repair the following: <ul style="list-style-type: none"> <li>● Open circuit in harness between ignition coil &amp; ignitor assembly connector and engine grounding terminal</li> </ul>
4	<p><b>CHECK IGNITION COIL &amp; IGNITOR ASSEMBLY.</b>                      1) Remove spark plug cords.                      2) Measure resistance between spark plug cord contact portions to check secondary coil.  <b>Terminals</b>  <b>No. 1 — No. 2:</b></p>	Is the resistance between 10 and 15 k $\Omega$ ?	Go to step 5.	Replace ignition coil & ignitor assembly. <Ref. to IG(SOHC)-8, Ignition Coil and Ignitor Assembly.>
5	<p><b>CHECK IGNITION COIL &amp; IGNITOR ASSEMBLY.</b>                      Measure resistance between spark plug cord contact portions to check secondary coil.  <b>Terminals</b>  <b>No. 3 — No. 4:</b></p>	Is the resistance between 10 and 15 k $\Omega$ ?	Go to step 6.	Replace ignition coil & ignitor assembly. <Ref. to IG(SOHC)-8, Ignition Coil and Ignitor Assembly.>

# DIAGNOSTICS FOR ENGINE STARTING FAILURE

Engine (Diagnostics)

No.	Step	Check	Yes	No
6	<p><b>CHECK INPUT SIGNAL FOR IGNITION COIL &amp; IGNITOR ASSEMBLY.</b>                      1) Connect connector to ignition coil &amp; ignitor assembly.                      2) Check if voltage varies synchronously with engine speed when cranking, while monitoring voltage between ignition coil &amp; ignitor assembly connector and engine ground.  <b>Connector &amp; terminal</b>  <b>(E12) No. 1 (+) — Engine ground (-):</b></p>	Is the voltage more than 10 V?	Go to step 7.	Replace ignition coil & ignitor assembly. <Ref. to IG(SOHC)-8, Ignition Coil and Ignitor Assembly.>
7	<p><b>CHECK INPUT SIGNAL FOR IGNITION COIL &amp; IGNITOR ASSEMBLY.</b>                      Check if voltage varies synchronously with engine speed when cranking, while monitoring voltage between ignition coil &amp; ignitor assembly connector and engine ground.  <b>Connector &amp; terminal</b>  <b>(E12) No. 4 (+) — Engine ground (-):</b></p>	Is the voltage more than 10 V?	Go to step 8.	Replace ignition coil & ignitor assembly. <Ref. to IG(SOHC)-8, Ignition Coil and Ignitor Assembly.>
8	<p><b>CHECK HARNESS BETWEEN ECM AND IGNITION COIL &amp; IGNITOR ASSEMBLY CONNECTOR.</b>                      1) Turn ignition switch to OFF.                      2) Disconnect connector from ECM.                      3) Disconnect connector from ignition coil &amp; ignitor assembly.                      4) Measure resistance of harness between ECM and ignition coil &amp; ignitor assembly connector.  <b>Connector &amp; terminal</b>  <b>(B134) No. 25 — (E12) No. 1:</b></p>	Is the resistance less than 1 $\Omega$ ?	Go to step 9.	Repair harness and connector. NOTE: In this case, repair the following: <ul style="list-style-type: none"> <li>● Open circuit in harness between ECM and ignition coil &amp; ignitor assembly connector</li> <li>● Poor contact in coupling connector (B22)</li> </ul>
9	<p><b>CHECK HARNESS BETWEEN ECM AND IGNITION COIL &amp; IGNITOR ASSEMBLY CONNECTOR.</b>                      Measure resistance of harness between ECM and ignition coil &amp; ignitor assembly connector.  <b>Connector &amp; terminal</b>  <b>(B134) No. 26 — (E12) No. 4:</b></p>	Is the resistance less than 1 $\Omega$ ?	Go to step 10.	Repair harness and connector. NOTE: In this case, repair the following: <ul style="list-style-type: none"> <li>● Open circuit in harness between ECM and ignition coil &amp; ignitor assembly connector</li> <li>● Poor contact in coupling connector (B22)</li> </ul>
10	<p><b>CHECK HARNESS BETWEEN ECM AND IGNITION COIL &amp; IGNITOR ASSEMBLY CONNECTOR.</b>                      Measure resistance of harness between ECM and engine ground.  <b>Connector &amp; terminal:</b>  <b>(B134) No. 25 — Engine ground:</b></p>	Is the resistance more than 1 M $\Omega$ ?	Go to step 11.	Repair ground short circuit in harness between ECM and ignition coil & ignitor assembly connector.

# DIAGNOSTICS FOR ENGINE STARTING FAILURE

Engine (Diagnostics)

No.	Step	Check	Yes	No
11	<b>CHECK HARNESS BETWEEN ECM AND IGNITION COIL &amp; IGNITOR ASSEMBLY CONNECTOR.</b> Measure resistance of harness between ECM and engine ground. <i>Connector &amp; terminal (B134) No. 26 — Engine ground:</i>	Is the resistance more than 1 M $\Omega$ ?	Go to step 12.	Repair ground short circuit in harness between ECM and ignition coil & ignitor assembly connector.
12	<b>CHECK POOR CONTACT.</b> Check poor contact in ECM connector.	Is there poor contact in ECM connector?	Repair poor contact in ECM connector.	Check fuel pump circuit. <Ref. to EN(SOHC)-72, FUEL PUMP CIRCUIT, Diagnostics for Engine Starting Failure.>

# DIAGNOSTICS FOR ENGINE STARTING FAILURE

Engine (Diagnostics)

## E: FUEL PUMP CIRCUIT

S058533E96

### CAUTION:

After repair or replacement of faulty parts, conduct CLEAR MEMORY MODE <Ref. to EN(SOHC)-45, Clear Memory Mode.> and INSPECTION MODE <Ref. to EN(SOHC)-42, Inspection Mode.>

### ● WIRING DIAGRAM:

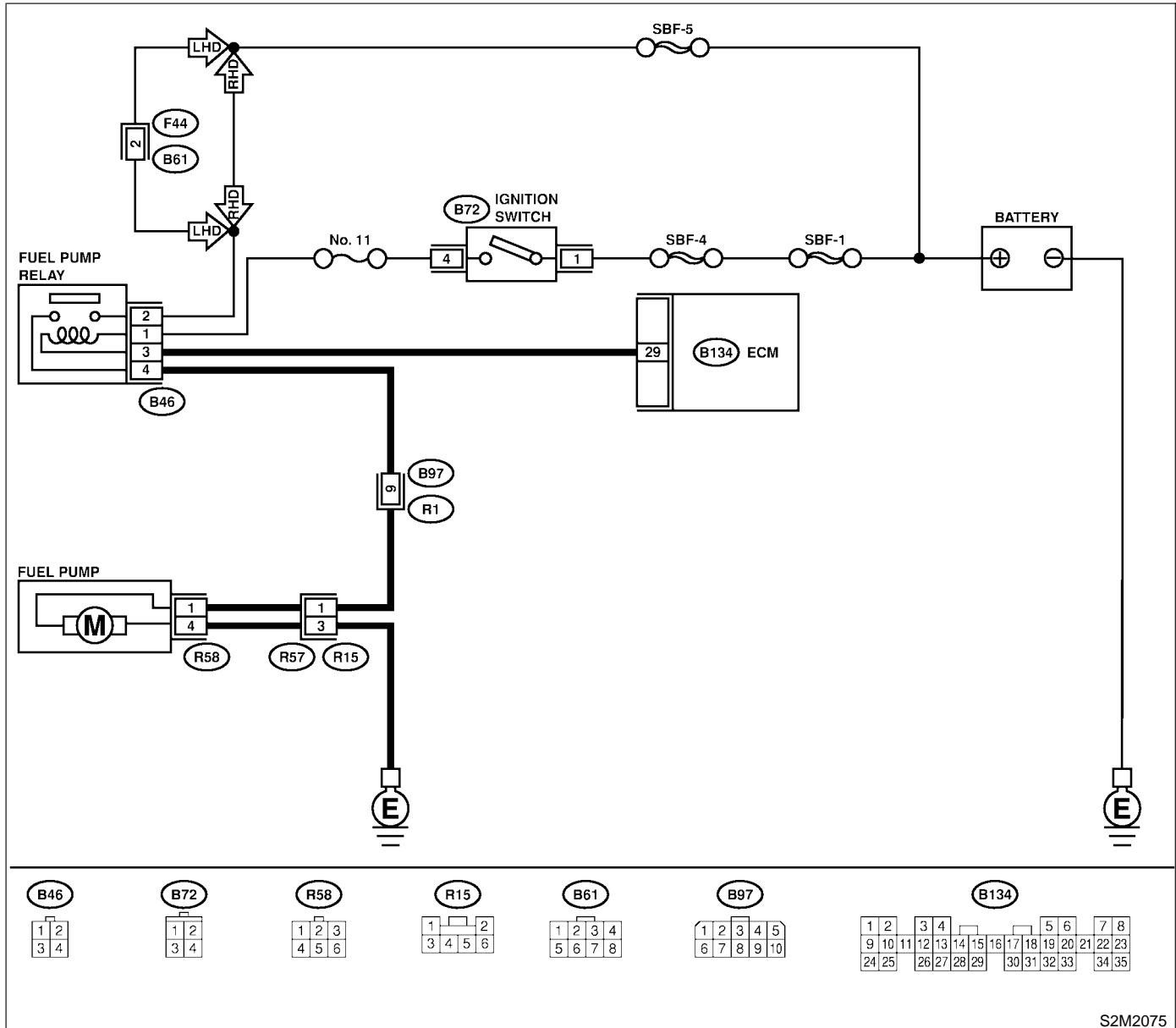

S2M2075



# DIAGNOSTICS FOR ENGINE STARTING FAILURE

Engine (Diagnostics)

No.	Step	Check	Yes	No
1	<p><b>CHECK OPERATING SOUND OF FUEL PUMP.</b>                      Make sure that fuel pump is in operation for two seconds when turning ignition switch to ON.                      NOTE:                      Fuel pump operation can also be executed using Subaru Select Monitor (Function mode: FD01).                      For the procedure, refer to "Compulsory Valve Operation Check Mode". &lt;Ref. to EN(SOHC)-46, Compulsory Valve Operation Check Mode.&gt;</p>	Does fuel pump produce operating sound?	Check fuel injector circuit. <Ref. to EN(SOHC)-76, FUEL INJECTOR CIRCUIT, Diagnostics for Engine Starting Failure.>	Go to step 2.
2	<p><b>CHECK GROUND CIRCUIT OF FUEL PUMP.</b>                      1) Turn ignition switch to OFF.                      2) Remove fuel pump access hole lid located on the right rear of trunk compartment floor (Sedan) or luggage compartment floor (Wagon).                      3) Disconnect connector from fuel pump.                      4) Measure resistance of harness connector between fuel pump and chassis ground.  <b>Connector &amp; terminal</b>  <b>(R58) No. 4 — Chassis ground:</b></p>	Is the resistance less than 5 Ω?	Go to step 3.	Repair harness and connector. NOTE: In this case, repair the following: <ul style="list-style-type: none"> <li>● Open circuit in harness between fuel pump connector and chassis grounding terminal</li> <li>● Poor contact in coupling connector (R15)</li> </ul>
3	<p><b>CHECK POWER SUPPLY TO FUEL PUMP.</b>                      1) Turn ignition switch to ON.                      2) Measure voltage of power supply circuit between fuel pump connector and chassis ground.  <b>Connector &amp; terminal</b>  <b>(R58) No. 1 (+) — Chassis ground (-):</b></p>	Is the voltage more than 10 V?	Replace fuel pump. <Ref. to FU(SOHC)-62, Fuel Pump.>	Go to step 4.
4	<p><b>CHECK HARNESS BETWEEN FUEL PUMP AND FUEL PUMP RELAY CONNECTOR.</b>                      1) Turn ignition switch to OFF.                      2) Measure resistance of harness connector between fuel pump and fuel pump relay.  <b>Connector &amp; terminal</b>  <b>(R58) No. 1 — (B46) No. 4:</b></p>	Is the resistance less than 1 Ω?	Go to step 5.	Repair harness and connector. NOTE: In this case, repair the following: <ul style="list-style-type: none"> <li>● Open circuit in harness between fuel pump connector and chassis grounding terminal</li> <li>● Poor contact in coupling connectors R15 and B97</li> </ul>
5	<p><b>CHECK HARNESS BETWEEN FUEL PUMP AND FUEL PUMP RELAY CONNECTOR.</b>                      Measure resistance of harness between fuel pump and fuel pump relay connector.  <b>Connector &amp; terminal</b>  <b>(R58) No. 1 — Chassis ground:</b></p>	Is the resistance more than 1 MΩ?	Go to step 6.	Repair short circuit in harness between fuel pump and fuel pump relay connector.

# DIAGNOSTICS FOR ENGINE STARTING FAILURE

Engine (Diagnostics)

No.	Step	Check	Yes	No
6	<p><b>CHECK FUEL PUMP RELAY.</b></p> <p>1) Disconnect connectors from fuel pump relay and main relay.</p> <p>2) Remove fuel pump relay and main relay with bracket.</p> <p>3) Connect battery to fuel pump relay connector terminals No. 1 and No. 3.</p> <p>4) Measure resistance between connector terminals of fuel pump relay.</p> <p><b>Terminals</b> <b>No. 2 — No. 4:</b></p>	Is the resistance less than 10 Ω?	Go to step 7.	Replace fuel pump relay. <Ref. to FU(SOHC)-51, Fuel Pump Relay.>
7	<p><b>CHECK HARNESS BETWEEN ECM AND FUEL PUMP RELAY CONNECTOR.</b></p> <p>1) Disconnect connectors from ECM.</p> <p>2) Measure resistance of harness between ECM and fuel pump relay connector.</p> <p><b>Connector &amp; terminal</b> <b>(B134) No. 29 — (B46) No. 3:</b></p>	Is the resistance less than 1 Ω?	Go to step 8.	Repair open circuit in harness between ECM and fuel pump relay connector.
8	<p><b>CHECK POOR CONTACT.</b></p> <p>Check poor contact in ECM connector.</p>	Is there poor contact in ECM connector?	Repair poor contact in ECM connector.	Check fuel injector circuit. <Ref. to EN(SOHC)-76, FUEL INJECTOR CIRCUIT, Diagnostics for Engine Starting Failure.>

**MEMO:**

# DIAGNOSTICS FOR ENGINE STARTING FAILURE

Engine (Diagnostics)

## F: FUEL INJECTOR CIRCUIT

S058533E97

### CAUTION:

- Check or repair only faulty parts.
- After repair or replacement of faulty parts, conduct CLEAR MEMORY MODE <Ref. to EN(SOHC)-45, Clear Memory Mode.> and INSPECTION MODE. <Ref. to EN(SOHC)-42, Inspection Mode.>

### • WIRING DIAGRAM:

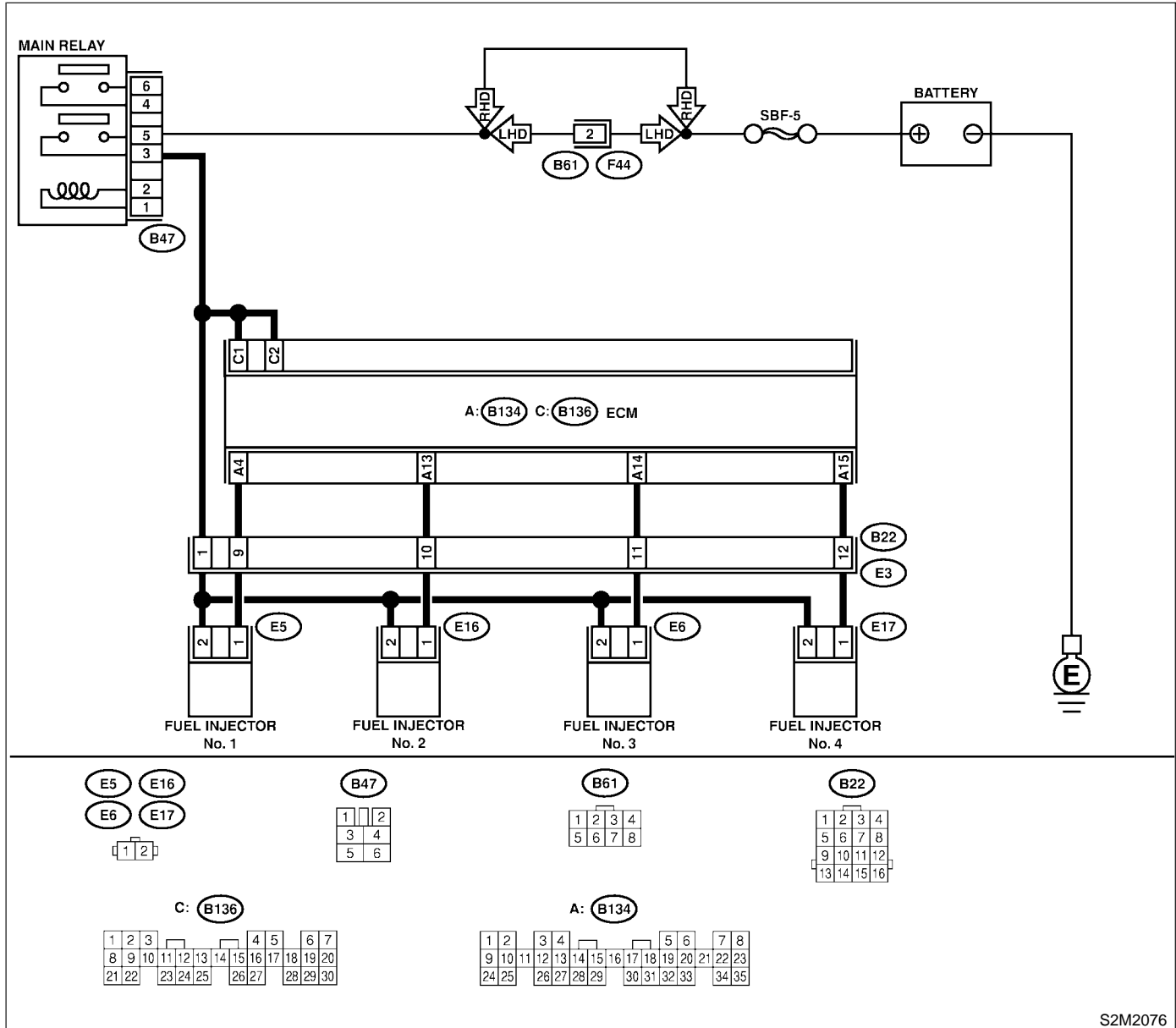

S2M2076

No.	Step	Check	Yes	No
1	<b>CHECK OPERATION OF EACH FUEL INJECTOR.</b> While cranking the engine, check that each fuel injector emits "operating" sound. Use a sound scope or attach a screwdriver to injector for this check.	Is the fuel injector emits "operating" sound?	Check fuel pressure. <Ref. to ME(SOHC)-28, INSPECTION, Fuel Pressure.>	Go to step 2.

# DIAGNOSTICS FOR ENGINE STARTING FAILURE

Engine (Diagnostics)

No.	Step	Check	Yes	No
2	<p><b>CHECK POWER SUPPLY TO EACH FUEL INJECTOR.</b></p> <p>1) Turn ignition switch to OFF.                      2) Disconnect connector from #1 cylinder fuel injector.                      3) Turn ignition switch to ON.                      4) Measure power supply voltage between the fuel injector terminal and engine ground.</p> <p><b>Connector &amp; terminal</b>  <b>#1 (E5) No. 2 (+) — Engine ground (-):</b>  <b>#2 (E16) No. 2 (+) — Engine ground (-):</b>  <b>#3 (E6) No. 2 (+) — Engine ground (-):</b>  <b>#4 (E17) No. 2 (+) — Engine ground (-):</b></p>	Is the voltage more than 10 V?	Go to step 3.	Repair harness and connector. NOTE: In this case, repair the following: ● Open circuit in harness between main relay and fuel injector connector ● Poor contact in main relay connector ● Poor contact in coupling connector (B22) ● Poor contact in fuel injector connector
3	<p><b>CHECK HARNESS BETWEEN ECM AND FUEL INJECTOR CONNECTOR.</b></p> <p>1) Disconnect connector from ECM.                      2) Measure resistance of harness between ECM and fuel injector connector.</p> <p><b>Connector &amp; terminal</b>  <b>(B134) No. 4 — (B136) No. 2:</b></p>	Is the resistance between 5 and 20 $\Omega$ ?	Go to step 4.	Repair harness and connector. NOTE: In this case, repair the following: ● Open circuit in harness between ECM and fuel injector connector ● Poor contact in coupling connector (B22)
4	<p><b>CHECK HARNESS BETWEEN ECM AND FUEL INJECTOR CONNECTOR.</b></p> <p>Measure resistance of harness between ECM and fuel injector connector.</p> <p><b>Connector &amp; terminal</b>  <b>(B134) No. 4 — Chassis ground:</b></p>	Is the resistance less than 1 $\Omega$ ?	Repair ground short circuit in harness between ECM and fuel injector connector.	Go to step 5.
5	<p><b>CHECK HARNESS BETWEEN ECM AND FUEL INJECTOR CONNECTOR.</b></p> <p>Measure resistance of harness between ECM and fuel injector connector.</p> <p><b>Connector &amp; terminal</b>  <b>(B134) No. 13 — (B136) No. 2:</b></p>	Is the resistance between 5 and 20 $\Omega$ ?	Go to step 6.	Repair harness and connector. NOTE: In this case, repair the following: ● Open circuit in harness between ECM and fuel injector connector ● Poor contact in coupling connector (B22)
6	<p><b>CHECK HARNESS BETWEEN ECM AND FUEL INJECTOR CONNECTOR.</b></p> <p>Measure resistance of harness between ECM and fuel injector connector.</p> <p><b>Connector &amp; terminal</b>  <b>(B134) No. 13 — Chassis ground:</b></p>	Is the resistance less than 1 $\Omega$ ?	Repair ground short circuit in harness between ECM and fuel injector connector.	Go to step 7.

# DIAGNOSTICS FOR ENGINE STARTING FAILURE

Engine (Diagnostics)

No.	Step	Check	Yes	No
7	<p><b>CHECK HARNESS BETWEEN ECM AND FUEL INJECTOR CONNECTOR.</b>                      Measure resistance of harness between ECM and fuel injector connector.  <i>Connector &amp; terminal</i>                      (B134) No. 14 — (B136) No. 2:</p>	Is the resistance between 5 and 20 $\Omega$ ?	Go to step 8.	Repair harness and connector. NOTE: In this case, repair the following: <ul style="list-style-type: none"> <li>● Open circuit in harness between ECM and fuel injector connector</li> <li>● Poor contact in coupling connector (B22)</li> </ul>
8	<p><b>CHECK HARNESS BETWEEN ECM AND FUEL INJECTOR CONNECTOR.</b>                      Measure resistance of harness between ECM and fuel injector connector.  <i>Connector &amp; terminal</i>                      (B134) No. 14 — Chassis ground:</p>	Is the resistance less than 1 $\Omega$ ?	Repair ground short circuit in harness between ECM and fuel injector connector.	Go to step 9.
9	<p><b>CHECK HARNESS BETWEEN ECM AND FUEL INJECTOR CONNECTOR.</b>                      Measure resistance of harness between ECM and fuel injector connector.  <i>Connector &amp; terminal</i>                      (B134) No. 15 — (B136) No. 2:</p>	Is the resistance between 5 and 20 $\Omega$ ?	Go to step 10.	Repair harness and connector. NOTE: In this case, repair the following: <ul style="list-style-type: none"> <li>● Open circuit in harness between ECM and fuel injector connector</li> <li>● Poor contact in coupling connector (B22)</li> </ul>
10	<p><b>CHECK HARNESS BETWEEN ECM AND FUEL INJECTOR CONNECTOR.</b>                      Measure resistance of harness between ECM and fuel injector connector.  <i>Connector &amp; terminal</i>                      (B134) No. 15 — Chassis ground:</p>	Is the resistance less than 1 $\Omega$ ?	Repair ground short circuit in harness between ECM and fuel injector connector.	Go to step 11.
11	<p><b>CHECK EACH FUEL INJECTOR.</b>                      1) Turn ignition switch to OFF.                      2) Measure resistance between each fuel injector terminals.  <i>Terminals</i>                      No. 1 — No. 2:</p>	Is the resistance between 5 and 20 $\Omega$ ?	Go to step 12.	Replace faulty fuel injector.
12	<p><b>CHECK POOR CONTACT.</b>                      Check poor contact in ECM connector.</p>	Is there poor contact in ECM connector?	Repair poor contact in ECM connector.	Inspection using "General Diagnostic Table". <Ref. to EN(SOHC)-294, INSPECTION, General Diagnostic Table.>

**MEMO:**

# LIST OF DIAGNOSTIC TROUBLE CODE (DTC)

Engine (Diagnostics)

## 17. List of Diagnostic Trouble Code (DTC)

S058525

### A: LIST

S058525A12

DTC No.	Item	Index
P0031	Front oxygen (A/F) sensor heater circuit low input	<Ref. to EN(SOHC)-86, DTC P0031 — FRONT OXYGEN (A/F) SENSOR HEATER CIRCUIT LOW INPUT —, Diagnostic Procedure with Diagnostic Trouble Code (DTC).>
P0032	Front oxygen (A/F) sensor heater circuit high input	<Ref. to EN(SOHC)-90, DTC P0032 — FRONT OXYGEN (A/F) SENSOR HEATER CIRCUIT HIGH INPUT —, Diagnostic Procedure with Diagnostic Trouble Code (DTC).>
P0037	Rear oxygen sensor heater circuit malfunction	<Ref. to EN(SOHC)-92, DTC P0037 — REAR OXYGEN SENSOR HEATER CIRCUIT MALFUNCTION —, Diagnostic Procedure with Diagnostic Trouble Code (DTC).>
P0038	Rear oxygen sensor heater circuit high input	<Ref. to EN(SOHC)-96, DTC P0038 — REAR OXYGEN SENSOR HEATER CIRCUIT HIGH INPUT —, Diagnostic Procedure with Diagnostic Trouble Code (DTC).>
P0066	Air assist injector solenoid valve circuit low input	<Ref. to EN(SOHC)-98, DTC P0066 — AIR ASSIST INJECTOR SOLENOID VALVE CIRCUIT LOW INPUT —, Diagnostic Procedure with Diagnostic Trouble Code (DTC).>
P0067	Air assist injector solenoid valve circuit high input	<Ref. to EN(SOHC)-100, DTC P0067 — AIR ASSIST INJECTOR SOLENOID VALVE CIRCUIT HIGH INPUT —, Diagnostic Procedure with Diagnostic Trouble Code (DTC).>
P0106	Pressure sensor circuit range/performance problem (low input)	<Ref. to EN(SOHC)-102, DTC P0106 — PRESSURE SENSOR CIRCUIT RANGE/PERFORMANCE PROBLEM (LOW INPUT) —, Diagnostic Procedure with Diagnostic Trouble Code (DTC).>
P0107	Pressure sensor circuit low input	<Ref. to EN(SOHC)-106, DTC P0107 — PRESSURE SENSOR CIRCUIT LOW INPUT —, Diagnostic Procedure with Diagnostic Trouble Code (DTC).>
P0108	Pressure sensor circuit high input	<Ref. to EN(SOHC)-110, DTC P0108 — PRESSURE SENSOR CIRCUIT HIGH INPUT —, Diagnostic Procedure with Diagnostic Trouble Code (DTC).>
P0111	Intake air temperature sensor circuit range/performance problem	<Ref. to EN(SOHC)-114, DTC P0111 — INTAKE AIR TEMPERATURE SENSOR CIRCUIT RANGE/PERFORMANCE PROBLEM —, Diagnostic Procedure with Diagnostic Trouble Code (DTC).>
P0112	Intake air temperature sensor circuit low input	<Ref. to EN(SOHC)-116, DTC P0112 — INTAKE AIR TEMPERATURE SENSOR CIRCUIT LOW INPUT —, Diagnostic Procedure with Diagnostic Trouble Code (DTC).>
P0113	Intake air temperature sensor circuit high input	<Ref. to EN(SOHC)-118, DTC P0113 — INTAKE AIR TEMPERATURE SENSOR CIRCUIT HIGH INPUT —, Diagnostic Procedure with Diagnostic Trouble Code (DTC).>
P0117	Engine coolant temperature sensor circuit low input	<Ref. to EN(SOHC)-122, DTC P0117 — ENGINE COOLANT TEMPERATURE SENSOR CIRCUIT LOW INPUT —, Diagnostic Procedure with Diagnostic Trouble Code (DTC).>
P0118	Engine coolant temperature sensor circuit high input	<Ref. to EN(SOHC)-124, DTC P0118 — ENGINE COOLANT TEMPERATURE SENSOR CIRCUIT HIGH INPUT —, Diagnostic Procedure with Diagnostic Trouble Code (DTC).>
P0121	Throttle position sensor circuit range/performance problem (high input)	<Ref. to EN(SOHC)-128, DTC P0121 — THROTTLE POSITION SENSOR CIRCUIT RANGE/PERFORMANCE PROBLEM (HIGH INPUT) —, Diagnostic Procedure with Diagnostic Trouble Code (DTC).>
P0122	Throttle position sensor circuit low input	<Ref. to EN(SOHC)-130, DTC P0122 — THROTTLE POSITION SENSOR CIRCUIT LOW INPUT —, Diagnostic Procedure with Diagnostic Trouble Code (DTC).>
P0123	Throttle position sensor circuit high input	<Ref. to EN(SOHC)-134, DTC P0123 — THROTTLE POSITION SENSOR CIRCUIT HIGH INPUT —, Diagnostic Procedure with Diagnostic Trouble Code (DTC).>



# LIST OF DIAGNOSTIC TROUBLE CODE (DTC)

Engine (Diagnostics)

DTC No.	Item	Index
P0125	Insufficient coolant temperature for closed loop fuel control	<Ref. to EN(SOHC)-136, DTC P0125 — INSUFFICIENT COOLANT TEMPERATURE FOR CLOSED LOOP FUEL CONTROL —, Diagnostic Procedure with Diagnostic Trouble Code (DTC).>
P0130	Front oxygen (A/F) sensor circuit range/performance problem (Lean)	<Ref. to EN(SOHC)-138, DTC P0130 — FRONT OXYGEN (A/F) SENSOR CIRCUIT RANGE/PERFORMANCE PROBLEM (LEAN) —, Diagnostic Procedure with Diagnostic Trouble Code (DTC).>
P0131	Front oxygen (A/F) sensor circuit malfunction (open circuit)	<Ref. to EN(SOHC)-142, DTC P0131 — FRONT OXYGEN (A/F) SENSOR CIRCUIT MALFUNCTION (OPEN CIRCUIT) —, Diagnostic Procedure with Diagnostic Trouble Code (DTC).>
P0132	Front oxygen (A/F) sensor circuit malfunction (short circuit)	<Ref. to EN(SOHC)-144, DTC P0132 — FRONT OXYGEN (A/F) SENSOR CIRCUIT MALFUNCTION (SHORT CIRCUIT) —, Diagnostic Procedure with Diagnostic Trouble Code (DTC).>
P0133	Front oxygen (A/F) sensor circuit slow response	<Ref. to EN(SOHC)-146, DTC P0133 — FRONT OXYGEN (A/F) SENSOR CIRCUIT SLOW RESPONSE —, Diagnostic Procedure with Diagnostic Trouble Code (DTC).>
P0136	Rear oxygen sensor circuit malfunction	<Ref. to EN(SOHC)-148, DTC P0136 — REAR OXYGEN SENSOR CIRCUIT MALFUNCTION —, Diagnostic Procedure with Diagnostic Trouble Code (DTC).>
P0139	Rear oxygen sensor circuit slow response	<Ref. to EN(SOHC)-152, DTC P0139 — REAR OXYGEN SENSOR CIRCUIT SLOW RESPONSE —, Diagnostic Procedure with Diagnostic Trouble Code (DTC).>
P0170	Fuel trim malfunction	<Ref. to EN(SOHC)-154, DTC P0170 — FUEL TRIM MALFUNCTION —, Diagnostic Procedure with Diagnostic Trouble Code (DTC).>
P0301	Cylinder 1 misfire detected	<Ref. to EN(SOHC)-156, DTC P0301 — CYLINDER 1 MISFIRE DETECTED —, Diagnostic Procedure with Diagnostic Trouble Code (DTC).>
P0302	Cylinder 2 misfire detected	<Ref. to EN(SOHC)-156, DTC P0302 — CYLINDER 2 MISFIRE DETECTED —, Diagnostic Procedure with Diagnostic Trouble Code (DTC).>
P0303	Cylinder 3 misfire detected	<Ref. to EN(SOHC)-156, DTC P0303 — CYLINDER 3 MISFIRE DETECTED —, Diagnostic Procedure with Diagnostic Trouble Code (DTC).>
P0304	Cylinder 4 misfire detected	<Ref. to EN(SOHC)-158, DTC P0304 — CYLINDER 4 MISFIRE DETECTED —, Diagnostic Procedure with Diagnostic Trouble Code (DTC).>
P0327	Knock sensor circuit low input	<Ref. to EN(SOHC)-166, DTC P0327 — KNOCK SENSOR CIRCUIT LOW INPUT —, Diagnostic Procedure with Diagnostic Trouble Code (DTC).>
P0328	Knock sensor circuit high input	<Ref. to EN(SOHC)-168, DTC P0328 — KNOCK SENSOR CIRCUIT HIGH INPUT —, Diagnostic Procedure with Diagnostic Trouble Code (DTC).>
P0335	Crankshaft position sensor circuit malfunction	<Ref. to EN(SOHC)-170, DTC P0335 — CRANKSHAFT POSITION SENSOR CIRCUIT MALFUNCTION —, Diagnostic Procedure with Diagnostic Trouble Code (DTC).>
P0336	Crankshaft position sensor circuit range/performance problem	<Ref. to EN(SOHC)-172, DTC P0336 — CRANKSHAFT POSITION SENSOR CIRCUIT RANGE/PERFORMANCE PROBLEM —, Diagnostic Procedure with Diagnostic Trouble Code (DTC).>
P0340	Camshaft position sensor circuit malfunction	<Ref. to EN(SOHC)-174, DTC P0340 — CAMSHAFT POSITION SENSOR CIRCUIT MALFUNCTION —, Diagnostic Procedure with Diagnostic Trouble Code (DTC).>
P0341	Camshaft position sensor circuit range/performance problem	<Ref. to EN(SOHC)-176, DTC P0341 — CAMSHAFT POSITION SENSOR CIRCUIT RANGE/PERFORMANCE PROBLEM —, Diagnostic Procedure with Diagnostic Trouble Code (DTC).>
P0420	Catalyst system efficiency below threshold	<Ref. to EN(SOHC)-180, DTC P0420 — CATALYST SYSTEM EFFICIENCY BELOW THRESHOLD —, Diagnostic Procedure with Diagnostic Trouble Code (DTC).>

## LIST OF DIAGNOSTIC TROUBLE CODE (DTC)

Engine (Diagnostics)

DTC No.	Item	Index
P0444	Evaporative emission control system purge control valve circuit low input	<Ref. to EN(SOHC)-182, DTC P0444 — EVAPORATIVE EMISSION CONTROL SYSTEM PURGE CONTROL VALVE CIRCUIT LOW INPUT —, Diagnostic Procedure with Diagnostic Trouble Code (DTC).>
P0445	Evaporative emission control system purge control valve circuit high input	<Ref. to EN(SOHC)-186, DTC P0445 — EVAPORATIVE EMISSION CONTROL SYSTEM PURGE CONTROL VALVE CIRCUIT HIGH INPUT —, Diagnostic Procedure with Diagnostic Trouble Code (DTC).>
P0461	Fuel level sensor circuit range/performance problem	<Ref. to EN(SOHC)-188, DTC P0461 — FUEL LEVEL SENSOR CIRCUIT RANGE/PERFORMANCE PROBLEM —, Diagnostic Procedure with Diagnostic Trouble Code (DTC).>
P0462	Fuel level sensor circuit low input	<Ref. to EN(SOHC)-190, DTC P0462 — FUEL LEVEL SENSOR CIRCUIT LOW INPUT —, Diagnostic Procedure with Diagnostic Trouble Code (DTC).>
P0463	Fuel level sensor circuit high input	<Ref. to EN(SOHC)-194, DTC P0463 — FUEL LEVEL SENSOR CIRCUIT HIGH INPUT —, Diagnostic Procedure with Diagnostic Trouble Code (DTC).>
P0464	Fuel level sensor intermittent input	<Ref. to EN(SOHC)-198, DTC P0464 — FUEL LEVEL SENSOR INTERMITTENT INPUT —, Diagnostic Procedure with Diagnostic Trouble Code (DTC).>
P0480	Cooling fan relay 1 circuit low input	<Ref. to EN(SOHC)-200, DTC P0480 — COOLING FAN RELAY 1 CIRCUIT LOW INPUT —, Diagnostic Procedure with Diagnostic Trouble Code (DTC).>
P0483	Cooling fan function problem	<Ref. to EN(SOHC)-204, DTC P0483 — COOLING FAN FUNCTION PROBLEM —, Diagnostic Procedure with Diagnostic Trouble Code (DTC).>
P0500	Vehicle speed sensor malfunction	<Ref. to EN(SOHC)-208, DTC P0500 — VEHICLE SPEED SENSOR MALFUNCTION —, Diagnostic Procedure with Diagnostic Trouble Code (DTC).>
P0506	Idle control system RPM lower than expected	<Ref. to EN(SOHC)-210, DTC P0506 — IDLE CONTROL SYSTEM RPM LOWER THAN EXPECTED —, Diagnostic Procedure with Diagnostic Trouble Code (DTC).>
P0507	Idle control system RPM higher than expected	<Ref. to EN(SOHC)-212, DTC P0507 — IDLE CONTROL SYSTEM RPM HIGHER THAN EXPECTED —, Diagnostic Procedure with Diagnostic Trouble Code (DTC).>
P0512	Starter switch circuit high input	<Ref. to EN(SOHC)-214, DTC P0512 — STARTER SWITCH CIRCUIT HIGH INPUT —, Diagnostic Procedure with Diagnostic Trouble Code (DTC).>
P0513	Incorrect immobilizer key	<Ref. to IM-34, DTC P0513 — INCORRECT IMMOBILIZER KEY (USE OF UNREGISTERED KEY) —, Diagnostics Chart with Trouble Code.>
P0562	Charge system circuit low input	<Ref. to EN(SOHC)-216, DTC P0562 — CHARGE SYSTEM CIRCUIT LOW INPUT —, Diagnostic Procedure with Diagnostic Trouble Code (DTC).>
P0563	Charge system circuit high input	<Ref. to EN(SOHC)-218, DTC P0563 — CHARGE SYSTEM CIRCUIT HIGH INPUT —, Diagnostic Procedure with Diagnostic Trouble Code (DTC).>
P0604	Internal control module memory check sum error	<Ref. to EN(SOHC)-220, DTC P0604 — INTERNAL CONTROL MODULE MEMORY CHECK SUM ERROR —, Diagnostic Procedure with Diagnostic Trouble Code (DTC).>
P0703	Brake switch input malfunction	<Ref. to EN(SOHC)-222, DTC P0703 — BRAKE SWITCH INPUT MALFUNCTION —, Diagnostic Procedure with Diagnostic Trouble Code (DTC).>
P0705	Transmission range sensor circuit malfunction	<Ref. to AT-122, CHECK INHIBITOR SWITCH., Diagnostic Procedure for No-trouble Code.>
P0710	Transmission fluid temperature sensor circuit malfunction	<Ref. to AT-46, TROUBLE CODE 27 — ATF TEMPERATURE SENSOR —, Diagnostic Procedure with Trouble Code.>
P0715	Torque converter turbine speed sensor circuit malfunction	<Ref. to AT-64, TROUBLE CODE 36 — TORQUE CONVERTER TURBINE SPEED SENSOR —, Diagnostic Procedure with Trouble Code.>

# LIST OF DIAGNOSTIC TROUBLE CODE (DTC)

Engine (Diagnostics)

DTC No.	Item	Index
P0720	Output speed sensor (Front vehicle speed sensor) circuit malfunction	<Ref. to AT-58, TROUBLE CODE 33 — FRONT VEHICLE SPEED SENSOR —, Diagnostic Procedure with Trouble Code.>
P0725	Engine speed input circuit malfunction	<Ref. to AT-42, TROUBLE CODE 11 — ENGINE SPEED SIGNAL —, Diagnostic Procedure with Trouble Code.>
P0731	Gear 1 incorrect ratio	<Ref. to EN(SOHC)-224, DTC P0731 — GEAR 1 INCORRECT RATIO —, Diagnostic Procedure with Diagnostic Trouble Code (DTC).>
P0732	Gear 2 incorrect ratio	<Ref. to EN(SOHC)-224, DTC P0732 — GEAR 2 INCORRECT RATIO —, Diagnostic Procedure with Diagnostic Trouble Code (DTC).>
P0733	Gear 3 incorrect ratio	<Ref. to EN(SOHC)-224, DTC P0733 — GEAR 3 INCORRECT RATIO —, Diagnostic Procedure with Diagnostic Trouble Code (DTC).>
P0734	Gear 4 incorrect ratio	<Ref. to EN(SOHC)-225, DTC P0734 — GEAR 4 INCORRECT RATIO —, Diagnostic Procedure with Diagnostic Trouble Code (DTC).>
P0741	Torque converter clutch system malfunction	<Ref. to EN(SOHC)-226, DTC P0741 — TORQUE CONVERTER CLUTCH SYSTEM MALFUNCTION —, Diagnostic Procedure with Diagnostic Trouble Code (DTC).>
P0743	Torque converter clutch system (Lock-up duty solenoid) electrical	<Ref. to AT-96, TROUBLE CODE 77 — LOCK-UP DUTY SOLENOID —, Diagnostic Procedure with Trouble Code.>
P0748	Pressure control solenoid (Line pressure duty solenoid) electrical	<Ref. to AT-88, TROUBLE CODE 75 — LINE PRESSURE DUTY SOLENOID —, Diagnostic Procedure with Trouble Code.>
P0753	Shift solenoid A (Shift solenoid 1) electrical	<Ref. to AT-72, TROUBLE CODE 71 — SHIFT SOLENOID 1 —, Diagnostic Procedure with Trouble Code.>
P0758	Shift solenoid B (Shift solenoid 2) electrical	<Ref. to AT-76, TROUBLE CODE 72 — SHIFT SOLENOID 2 —, Diagnostic Procedure with Trouble Code.>
P0778	2-4 brake pressure control solenoid valve circuit malfunction	<Ref. to AT-92, TROUBLE CODE 76 — 2-4 BRAKE DUTY SOLENOID —, Diagnostic Procedure with Trouble Code.>
P0785	2-4 brake timing control solenoid valve circuit malfunction	<Ref. to AT-84, TROUBLE CODE 74 — 2-4 BRAKE TIMING SOLENOID —, Diagnostic Procedure with Trouble Code.>
P1110	Atmospheric pressure sensor low input	<Ref. to EN(SOHC)-228, DTC P1110 — ATMOSPHERIC PRESSURE SENSOR CIRCUIT LOW INPUT —, Diagnostic Procedure with Diagnostic Trouble Code (DTC).>
P1111	Atmospheric pressure sensor high input	<Ref. to EN(SOHC)-232, DTC P1111 — ATMOSPHERIC PRESSURE SENSOR CIRCUIT HIGH INPUT —, Diagnostic Procedure with Diagnostic Trouble Code (DTC).>
P1112	Atmospheric pressure sensor range/performance problem	<Ref. to EN(SOHC)-236, DTC P1112 — ATMOSPHERIC PRESSURE SENSOR CIRCUIT RANGE/PERFORMANCE PROBLEM —, Diagnostic Procedure with Diagnostic Trouble Code (DTC).>
P1137	Front oxygen (A/F) sensor circuit range/performance problem	<Ref. to EN(SOHC)-238, DTC P1137 — FRONT OXYGEN (A/F) SENSOR CIRCUIT RANGE/PERFORMANCE PROBLEM —, Diagnostic Procedure with Diagnostic Trouble Code (DTC).>
P1142	Throttle position sensor circuit range/performance problem (low input)	<Ref. to EN(SOHC)-242, DTC P1142 — THROTTLE POSITION SENSOR CIRCUIT RANGE/PERFORMANCE PROBLEM (LOW INPUT) —, Diagnostic Procedure with Diagnostic Trouble Code (DTC).>
P1146	Pressure sensor circuit range/performance problem (high input)	<Ref. to EN(SOHC)-244, DTC P1146 — PRESSURE SENSOR CIRCUIT RANGE/PERFORMANCE PROBLEM (HIGH INPUT) —, Diagnostic Procedure with Diagnostic Trouble Code (DTC) for.>
P1442	Fuel level sensor circuit range/performance problem 2	<Ref. to EN(SOHC)-248, DTC P1442 — FUEL LEVEL SENSOR CIRCUIT RANGE/PERFORMANCE PROBLEM 2 —, Diagnostic Procedure with Diagnostic Trouble Code (DTC).>
P1480	Cooling fan relay 1 circuit high input	<Ref. to EN(SOHC)-250, DTC P1480 — COOLING FAN RELAY 1 CIRCUIT HIGH INPUT —, Diagnostic Procedure with Diagnostic Trouble Code (DTC).>
P1507	Idle control system malfunction (fail-safe)	<Ref. to EN(SOHC)-254, DTC P1507 — IDLE CONTROL SYSTEM MALFUNCTION (FAIL-SAFE) —, Diagnostic Procedure with Diagnostic Trouble Code (DTC).>

## LIST OF DIAGNOSTIC TROUBLE CODE (DTC)

Engine (Diagnostics)

DTC No.	Item	Index
P1510	Idle air control solenoid valve signal 1 circuit low input	<Ref. to EN(SOHC)-256, DTC P1510 — IDLE AIR CONTROL SOLENOID VALVE SIGNAL 1 CIRCUIT LOW INPUT —, Diagnostic Procedure with Diagnostic Trouble Code (DTC).>
P1511	Idle air control solenoid valve signal 1 circuit high input	<Ref. to EN(SOHC)-256, DTC P1511 — IDLE AIR CONTROL SOLENOID VALVE SIGNAL 1 CIRCUIT HIGH INPUT —, Diagnostic Procedure with Diagnostic Trouble Code (DTC).>
P1512	Idle air control solenoid valve signal 2 circuit low input	<Ref. to EN(SOHC)-256, DTC P1512 — IDLE AIR CONTROL SOLENOID VALVE SIGNAL 2 CIRCUIT LOW INPUT —, Diagnostic Procedure with Diagnostic Trouble Code (DTC).>
P1513	Idle air control solenoid valve signal 2 circuit high input	<Ref. to EN(SOHC)-256, DTC P1513 — IDLE AIR CONTROL SOLENOID VALVE SIGNAL 2 CIRCUIT HIGH INPUT —, Diagnostic Procedure with Diagnostic Trouble Code (DTC).>
P1514	Idle air control solenoid valve signal 3 circuit low input	<Ref. to EN(SOHC)-256, DTC P1514 — IDLE AIR CONTROL SOLENOID VALVE SIGNAL 3 CIRCUIT LOW INPUT —, Diagnostic Procedure with Diagnostic Trouble Code (DTC).>
P1515	Idle air control solenoid valve signal 3 circuit high input	<Ref. to EN(SOHC)-256, DTC P1515 — IDLE AIR CONTROL SOLENOID VALVE SIGNAL 3 CIRCUIT HIGH INPUT —, Diagnostic Procedure with Diagnostic Trouble Code (DTC).>
P1516	Idle air control solenoid valve signal 4 circuit low input	<Ref. to EN(SOHC)-258, DTC P1516 — IDLE AIR CONTROL SOLENOID VALVE SIGNAL 4 CIRCUIT LOW INPUT —, Diagnostic Procedure with Diagnostic Trouble Code (DTC).>
P1517	Idle air control solenoid valve signal 4 circuit high input	<Ref. to EN(SOHC)-262, DTC P1517 — IDLE AIR CONTROL SOLENOID VALVE SIGNAL 4 CIRCUIT HIGH INPUT —, Diagnostic Procedure with Diagnostic Trouble Code (DTC).>
P1518	Starter switch circuit low input	<Ref. to EN(SOHC)-264, DTC P1518 — STARTER SWITCH CIRCUIT LOW INPUT —, Diagnostic Procedure with Diagnostic Trouble Code (DTC).>
P1540	Vehicle speed sensor malfunction 2	<Ref. to EN(SOHC)-266, DTC P1540 — VEHICLE SPEED SENSOR MALFUNCTION 2 —, Diagnostic Procedure with Diagnostic Trouble Code (DTC).>
P1560	Back-up voltage circuit malfunction	<Ref. to EN(SOHC)-268, DTC P1560 — BACK-UP VOLTAGE CIRCUIT MALFUNCTION —, Diagnostic Procedure with Diagnostic Trouble Code (DTC).>
P1570	Antenna	<Ref. to IM-35, DTC P1570 — ANTENNA —, Diagnostics Chart with Trouble Code.>
P1571	Reference code incompatibility	<Ref. to IM-26, DTC P1571 — REFERENCE CODE INCOMPATIBILITY —, Diagnostics Chart with Trouble Code.>
P1572	IMM circuit failure except antenna circuit	<Ref. to IM-27, DTC P1572 — IMM CIRCUIT FAILURE (EXCEPT ANTENNA CIRCUIT) —, Diagnostics Chart with Trouble Code.>
P1574	Key communication failure	<Ref. to IM-33, DTC P1574 — KEY COMMUNICATION FAILURE —, Diagnostics Chart with Trouble Code.>
P1576	EGI control module EEPROM	<Ref. to IM-34, DTC P1576 — EGI CONTROL MODULE EEPROM —, Diagnostics Chart with Trouble Code.>
P1577	IMM control module EEPROM	<Ref. to IM-34, DTC P1577 — IMM CONTROL MODULE EEPROM —, Diagnostics Chart with Trouble Code.>
P1590	Neutral position switch circuit high input (AT model)	<Ref. to EN(SOHC)-270, DTC P1590 — NEUTRAL POSITION SWITCH CIRCUIT HIGH INPUT —, Diagnostic Procedure with Diagnostic Trouble Code (DTC).>
P1591	Neutral position switch circuit low input (AT model)	<Ref. to EN(SOHC)-274, DTC P1591 — NEUTRAL POSITION SWITCH CIRCUIT LOW INPUT —, Diagnostic Procedure with Diagnostic Trouble Code (DTC).>
P1592	Neutral position switch circuit (MT model)	<Ref. to EN(SOHC)-276, DTC P1592 — NEUTRAL POSITION SWITCH CIRCUIT LOW INPUT —, Diagnostic Procedure with Diagnostic Trouble Code (DTC).>

# LIST OF DIAGNOSTIC TROUBLE CODE (DTC)

Engine (Diagnostics)

DTC No.	Item	Index
P1594	Automatic transmission diagnosis input signal circuit malfunction	<Ref. to EN(SOHC)-278, DTC P1594 — AUTOMATIC TRANSMISSION DIAGNOSIS INPUT SIGNAL CIRCUIT MALFUNCTION —, Diagnostic Procedure with Diagnostic Trouble Code (DTC).>
P1595	Automatic transmission diagnosis input signal circuit low input	<Ref. to EN(SOHC)-280, DTC P1595 — AUTOMATIC TRANSMISSION DIAGNOSIS INPUT SIGNAL CIRCUIT LOW INPUT —, Diagnostic Procedure with Diagnostic Trouble Code (DTC).>
P1596	Automatic transmission diagnosis input signal circuit high input	<Ref. to EN(SOHC)-282, DTC P1596 — AUTOMATIC TRANSMISSION DIAGNOSIS INPUT SIGNAL CIRCUIT HIGH INPUT —, Diagnostic Procedure with Diagnostic Trouble Code (DTC).>
P1698	Engine torque control cut signal circuit low input	<Ref. to EN(SOHC)-284, DTC P1698 — ENGINE TORQUE CONTROL CUT SIGNAL CIRCUIT LOW INPUT —, Diagnostic Procedure with Diagnostic Trouble Code (DTC).>
P1699	Engine torque control cut signal circuit high input	<Ref. to EN(SOHC)-286, DTC P1699 — ENGINE TORQUE CONTROL CUT SIGNAL CIRCUIT HIGH INPUT —, Diagnostic Procedure with Diagnostic Trouble Code (DTC).>
P1700	Throttle position sensor circuit malfunction for automatic transmission	<Ref. to AT-50, TROUBLE CODE 31 — THROTTLE POSITION SENSOR —, Diagnostic Procedure with Trouble Code.>
P1701	Cruise control set signal circuit malfunction for automatic transmission	<Ref. to EN(SOHC)-288, DTC P1701 — CRUISE CONTROL SET SIGNAL CIRCUIT MALFUNCTION FOR AUTOMATIC TRANSMISSION —, Diagnostic Procedure with Diagnostic Trouble Code (DTC).>
P1703	Low clutch timing control solenoid valve circuit malfunction	<Ref. to AT-80, TROUBLE CODE 73 — LOW CLUTCH TIMING SOLENOID —, Diagnostic Procedure with Trouble Code.>
P1711	Engine torque control signal 1 circuit malfunction	<Ref. to EN(SOHC)-290, DTC P1711 — ENGINE TORQUE CONTROL SIGNAL 1 CIRCUIT MALFUNCTION —, Diagnostic Procedure with Diagnostic Trouble Code (DTC).>
P1712	Engine torque control signal 2 circuit malfunction	<Ref. to EN(SOHC)-292, DTC P1712 — ENGINE TORQUE CONTROL SIGNAL 2 CIRCUIT MALFUNCTION —, Diagnostic Procedure with Diagnostic Trouble Code (DTC).>

## 18. Diagnostic Procedure with Diagnostic Trouble Code (DTC) S058521

### A: DTC P0031 — FRONT OXYGEN (A/F) SENSOR HEATER CIRCUIT LOW INPUT — S058521F83

- DTC DETECTING CONDITION:
  - Immediately at fault recognition

**CAUTION:**

After repair or replacement of faulty parts, conduct Clear Memory Mode <Ref. to EN(SOHC)-45, OPERATION, Clear Memory Mode.> and Inspection Mode <Ref. to EN(SOHC)-42, OPERATION, Inspection Mode.>.

● WIRING DIAGRAM:

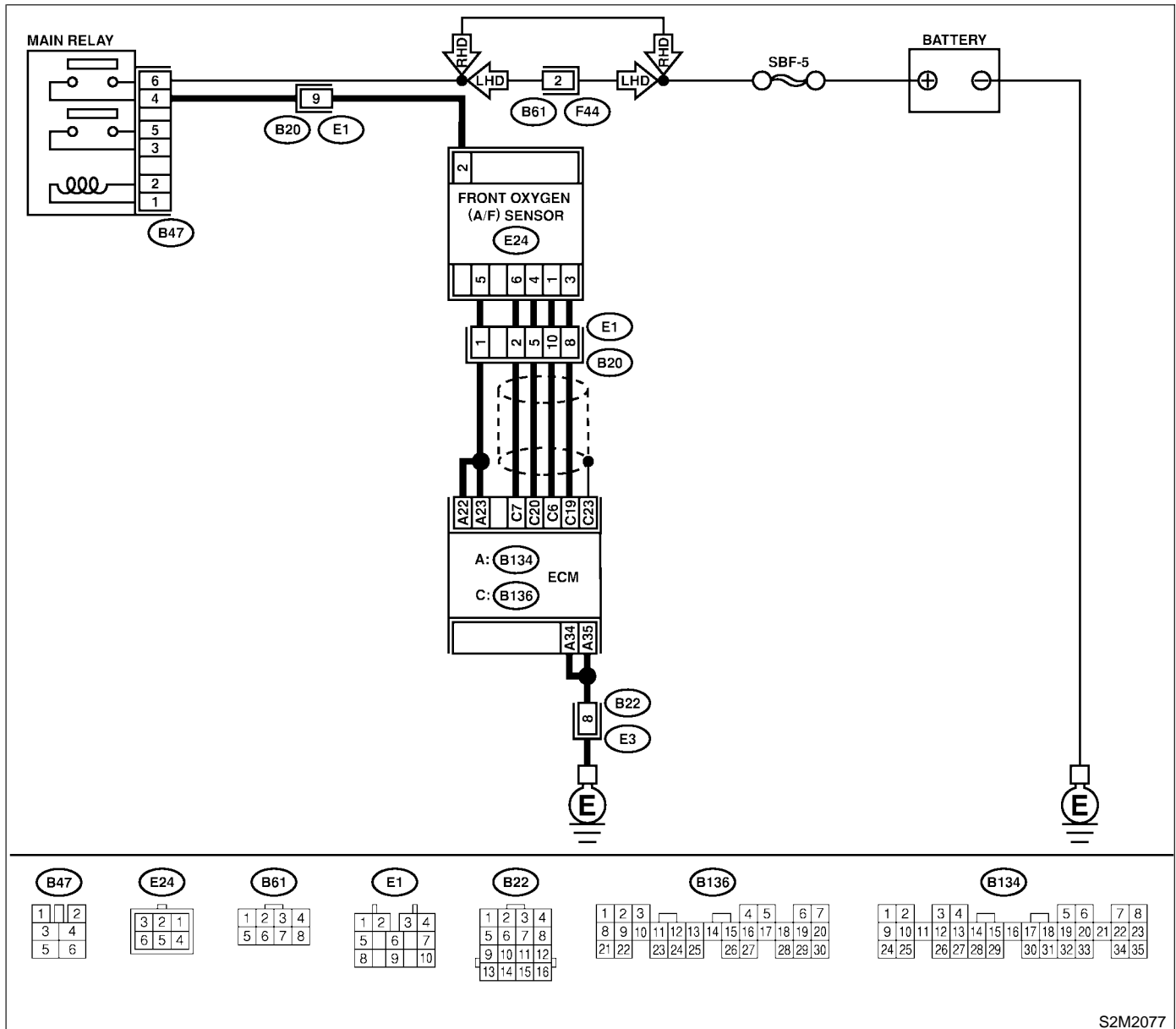

# DIAGNOSTIC PROCEDURE WITH DIAGNOSTIC TROUBLE CODE (DTC)

Engine (Diagnostics)

No.	Step	Check	Yes	No
1	<b>CHECK ANY OTHER DTC ON DISPLAY.</b>	Does the Subaru Select Monitor or OBD-II general scan tool indicate DTC P0031 and P0037 at the same time?	Go to step 2.	Go to step 5.
2	<b>CHECK POWER SUPPLY TO FRONT OXYGEN (A/F) SENSOR.</b> 1) Turn ignition switch to OFF. 2) Disconnect connector from front oxygen (A/F) sensor. 3) Turn ignition switch to ON. 4) Measure voltage between front oxygen (A/F) sensor connector and engine ground. <b>Connector &amp; terminal</b> <b>(E24) No. 2 (+) — Engine ground (-):</b>	Is the voltage more than 10 V?	Go to step 3.	Repair power supply line. NOTE: In this case, repair the following: ● Open circuit in harness between main relay and front oxygen (A/F) sensor connector ● Poor contact in front oxygen (A/F) sensor connector ● Poor contact in main relay connector
3	<b>CHECK GROUND CIRCUIT OF ECM.</b> Measure resistance of harness between ECM connector and chassis ground. <b>Connector &amp; terminal</b> <b>(B134) No. 35 — Chassis ground:</b> <b>(B134) No. 34 — Chassis ground:</b>	Is the resistance less than 5 Ω?	Go to step 4.	Repair harness and connector. NOTE: In this case, repair the following: ● Open circuit in harness between ECM and engine ground terminal ● Poor contact in ECM connector Poor contact in coupling connector (B22)
4	<b>CHECK CURRENT DATA.</b> 1) Start engine 2) Read data of front oxygen (A/F) sensor heater current using Subaru Select Monitor or OBD-II general scan tool. NOTE: ● Subaru Select Monitor For detailed operation procedure, refer to the "READ CURRENT DATA FOR ENGINE". <Ref. to EN(SOHC)-34, Subaru Select Monitor.> ● OBD-II scan tool For detailed operation procedures, refer to the OBD-II General Scan Tool Instruction Manual.	Is the value more than 0.2 A?	Repair poor contact in connector. NOTE: In this case, repair the following: ● Poor contact in front oxygen (A/F) sensor connector ● Poor contact in ECM connector	Go to step 5.
5	<b>CHECK OUTPUT SIGNAL FROM ECM.</b> 1) Start and idle the engine. 2) Measure voltage between ECM connector and chassis ground. <b>Connector &amp; terminal</b> <b>(B134) No. 22 (+) — Chassis ground (-):</b>	Is the voltage less than 1.0 V?	Go to step 7.	Go to step 6.

# DIAGNOSTIC PROCEDURE WITH DIAGNOSTIC TROUBLE CODE (DTC)

Engine (Diagnostics)

No.	Step	Check	Yes	No
6	<b>CHECK OUTPUT SIGNAL FROM ECM.</b> Measure voltage between ECM connector and chassis ground. <b>Connector &amp; terminal</b> <b>(B134) No. 22 (+) — Chassis ground (-):</b>	Does the voltage change less than 1.0 V by shaking harness and connector of ECM while monitoring the value with voltage meter?	Repair poor contact in ECM connector.	Go to step 7.
7	<b>CHECK OUTPUT SIGNAL FROM ECM.</b> Measure voltage between ECM connector and chassis ground. <b>Connector &amp; terminal</b> <b>(B134) No. 23 (+) — Chassis ground (-):</b>	Is the voltage less than 1.0 V?	Go to step 9.	Go to step 8.
8	<b>CHECK OUTPUT SIGNAL FROM ECM.</b> Measure voltage between ECM connector and chassis ground. <b>Connector &amp; terminal</b> <b>(B134) No. 23 (+) — Chassis ground (-):</b>	Does the voltage change less than 1.0 V by shaking harness and connector of ECM while monitoring the value with voltage meter?	Repair poor contact in ECM connector.	Go to step 9.
9	<b>CHECK FRONT OXYGEN (A/F) SENSOR.</b> 1) Turn ignition switch to OFF. 2) Measure resistance between front oxygen (A/F) sensor connector terminals. <b>Terminals</b> <b>No. 2 — No. 5:</b>	Is the resistance less than 10 Ω?	Repair harness and connector. NOTE: In this case, repair the following: <ul style="list-style-type: none"> <li>● Open or ground short circuit in harness between front oxygen (A/F) sensor and ECM connector</li> <li>● Poor contact in front oxygen (A/F) sensor connector</li> <li>● Poor contact in ECM connector</li> </ul>	Replace front oxygen (A/F) sensor. <Ref. to FU(SOHC)-45, Front Oxygen (A/F) Sensor.>



**MEMO:**

# DIAGNOSTIC PROCEDURE WITH DIAGNOSTIC TROUBLE CODE (DTC)

Engine (Diagnostics)

## B: DTC P0032 — FRONT OXYGEN (A/F) SENSOR HEATER CIRCUIT HIGH INPUT — S058521F84

- **DTC DETECTING CONDITION:**
  - Immediately at fault recognition

### CAUTION:

After repair or replacement of faulty parts, conduct Clear Memory Mode <Ref. to EN(SOHC)-45, OPERATION, Clear Memory Mode.> and Inspection Mode <Ref. to EN(SOHC)-42, OPERATION, Inspection Mode.>.

### ● WIRING DIAGRAM:

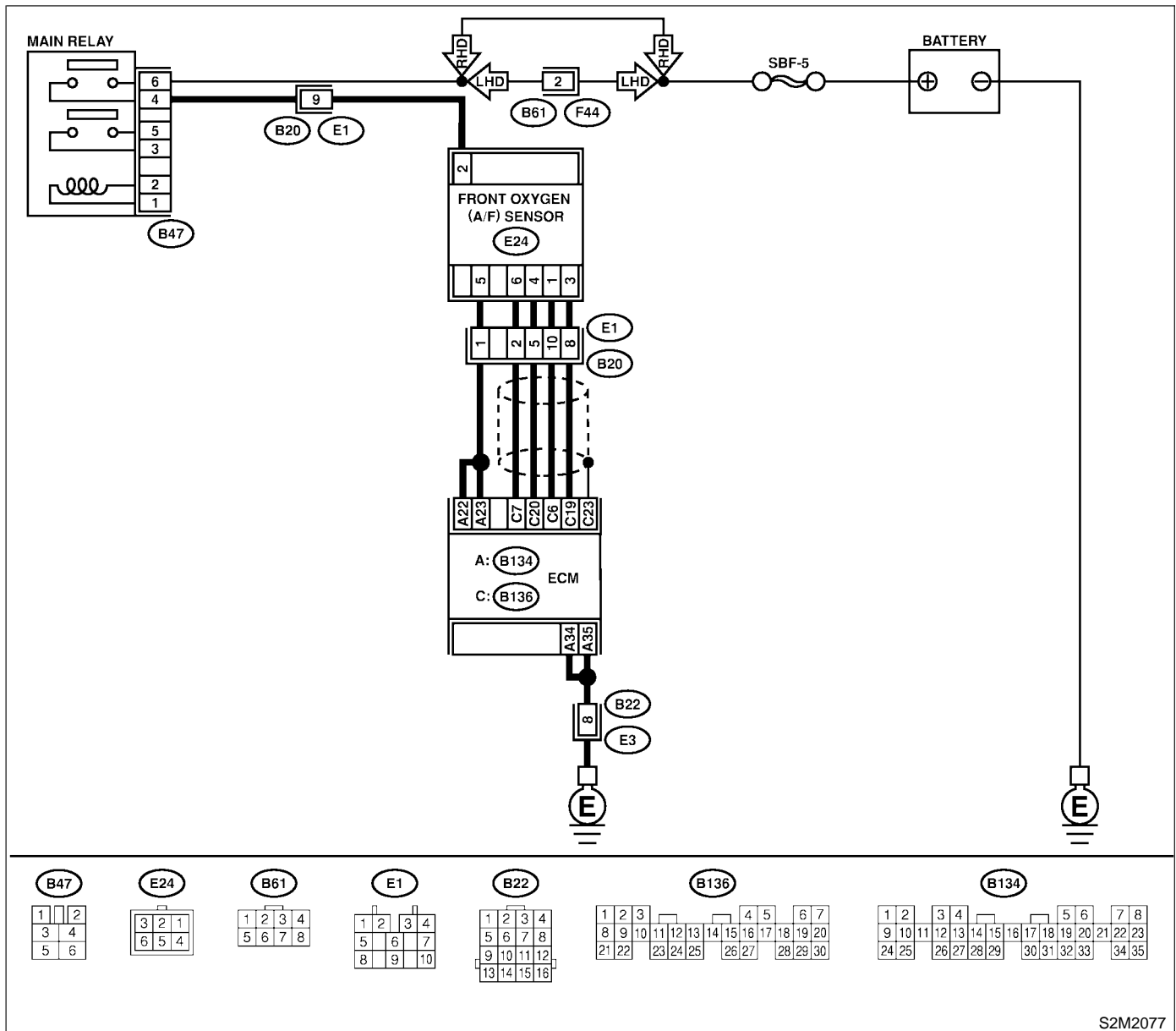

S2M2077

# DIAGNOSTIC PROCEDURE WITH DIAGNOSTIC TROUBLE CODE (DTC)

Engine (Diagnostics)

No.	Step	Check	Yes	No
1	<b>CHECK OUTPUT SIGNAL FROM ECM.</b> 1) Turn ignition switch to ON. 2) Measure voltage between ECM connector and chassis ground. <b>Connector &amp; terminal</b> <b>(B134) No. 23 (+) — Chassis ground (-):</b>	Is the voltage more than 8 V?	Go to step 3.	Go to step 2.
2	<b>CHECK OUTPUT SIGNAL FROM ECM.</b> Measure voltage between ECM connector and chassis ground. <b>Connector &amp; terminal</b> <b>(B134) No. 22 (+) — Chassis ground (-):</b>	Is the voltage more than 8 V?	Go to step 3.	Go to step 4.
3	<b>CHECK FRONT OXYGEN (A/F) SENSOR HEATER CURRENT.</b> 1) Turn ignition switch to OFF. 2) Repair battery short circuit in harness between ECM and front oxygen (A/F) sensor connector. 3) Turn ignition switch to ON. 4) Read data of front oxygen (A/F) sensor heater current using Subaru Select Monitor or the OBD-II general scan tool. NOTE: ● Subaru Select Monitor For detailed operation procedure, refer to the "READ CURRENT DATA FOR ENGINE". <Ref. to EN(SOHC)-34, Subaru Select Monitor.> ● OBD-II general scan tool For detailed operation procedure, refer to the OBD-II General Scan Tool Instruction Manual.	Is the value more than 2.3 A?	Replace ECM. <Ref. to FU(SOHC)-49, Engine Control Module.>	END
4	<b>CHECK OUTPUT SIGNAL FROM ECM.</b> Measure voltage between ECM connector and chassis ground. <b>Connector &amp; terminal</b> <b>(B134) No. 23 (+) — Chassis ground (-):</b>	Does the voltage change more than 8 V by shaking harness and connector of ECM while monitoring the value with voltage meter?	Repair battery short circuit in harness between ECM and front oxygen (A/F) sensor connector.	Go to step 5.
5	<b>CHECK OUTPUT SIGNAL FROM ECM.</b> Measure voltage between ECM connector and chassis ground. <b>Connector &amp; terminal</b> <b>(B134) No. 22 (+) — Chassis ground (-):</b>	Does the voltage change more than 8 V by shaking harness and connector of ECM while monitoring the value with voltage meter?	Repair battery short circuit in harness between ECM and front oxygen (A/F) sensor connector.	END

# DIAGNOSTIC PROCEDURE WITH DIAGNOSTIC TROUBLE CODE (DTC)

Engine (Diagnostics)

## C: DTC P0037 — REAR OXYGEN SENSOR HEATER CIRCUIT MALFUNCTION

— S058521F85

### ● DTC DETECTING CONDITION:

- Two consecutive driving cycles with fault

### CAUTION:

After repair or replacement of faulty parts, conduct Clear Memory Mode <Ref. to EN(SOHC)-45, OPERATION, Clear Memory Mode.> and Inspection Mode <Ref. to EN(SOHC)-42, OPERATION, Inspection Mode.>.

### ● WIRING DIAGRAM:

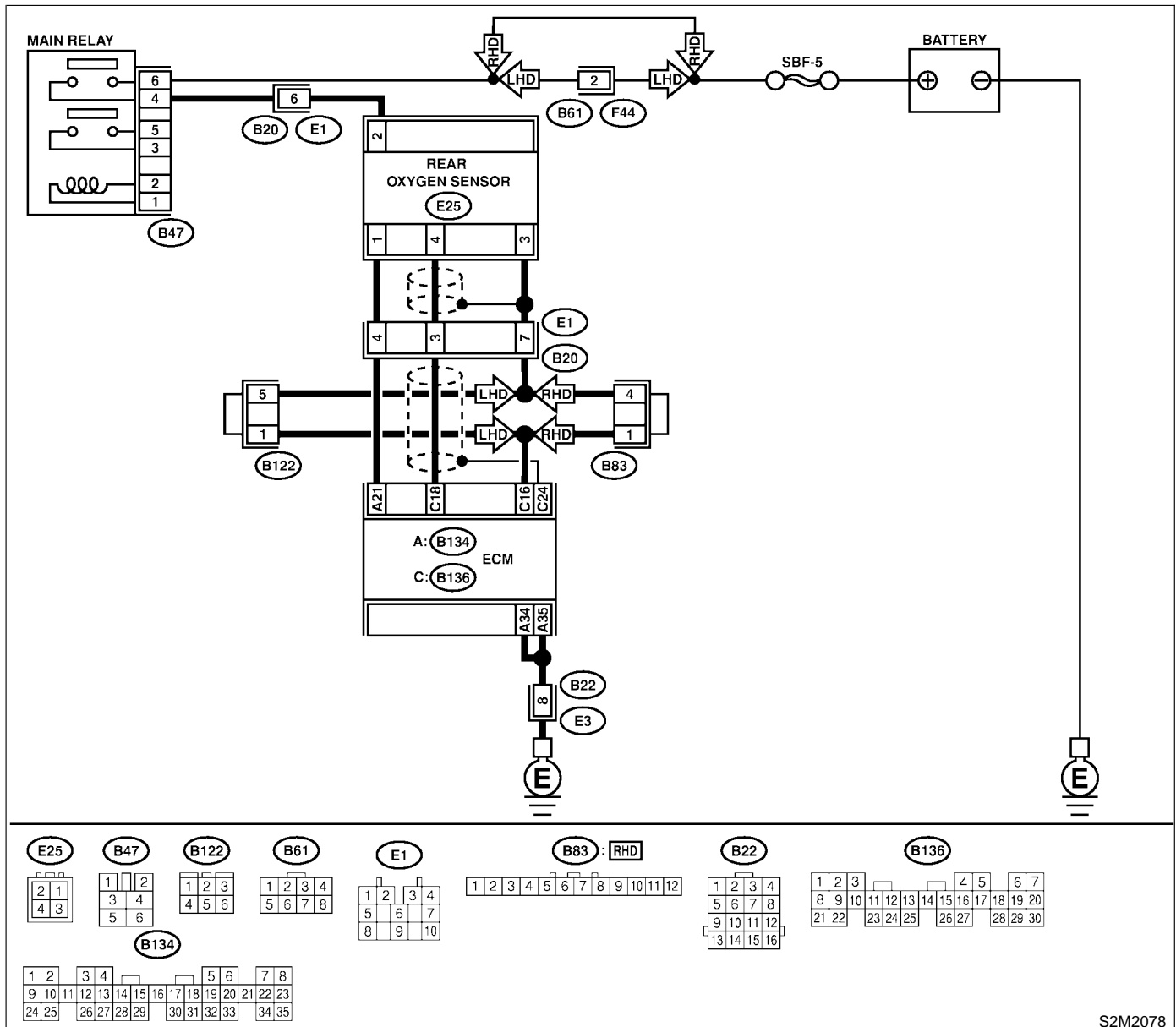

S2M2078

# DIAGNOSTIC PROCEDURE WITH DIAGNOSTIC TROUBLE CODE (DTC)

Engine (Diagnostics)

No.	Step	Check	Yes	No
1	<p><b>CHECK GROUND CIRCUIT OF ECM.</b>                      1) Turn ignition switch to OFF.                      2) Disconnect connector from ECM.                      3) Measure resistance of harness between ECM connector and chassis ground.  <b>Connector &amp; terminal</b>  <b>(B134) No. 35 — Chassis ground:</b></p>	Is the resistance less than 5 Ω?	Go to step 3.	Go to step 2.
2	<p><b>CHECK GROUND CIRCUIT OF ECM.</b>                      1) Repair harness and connector.                      NOTE:                      In this case, repair the following:                      ● Open circuit in harness between ECM and engine ground terminal                      ● Poor contact in ECM connector                      ● Poor contact in coupling connector (B22)                      2) Measure resistance of harness between ECM connector and chassis ground.  <b>Connector &amp; terminal</b>  <b>(B134) No. 34 — Chassis ground:</b></p>	Is the resistance less than 5 Ω?	Go to step 3.	Repair harness and connector. NOTE: In this case, repair the following: ● Open circuit in harness between ECM and engine ground terminal ● Poor contact in ECM connector ● Poor contact in coupling connector (B22)
3	<p><b>CHECK CURRENT DATA.</b>                      1) Start engine.                      2) Read data of rear oxygen sensor heater current using Subaru Select Monitor or OBD-II general scan tool.                      NOTE:                      ● Subaru Select Monitor                      For detailed operation procedure, refer to the "READ CURRENT DATA FOR ENGINE".                      &lt;Ref. to EN(SOHC)-34, Subaru Select Monitor.&gt;                      ● OBD-II scan tool                      For detailed operation procedures, refer to the OBD-II General Scan Tool Instruction Manual.</p>	Is the value more than 0.2 A?	Repair connector. NOTE: In this case, repair the following: ● Poor contact in rear oxygen sensor connector ● Poor contact in rear oxygen sensor connecting harness connector ● Poor contact in ECM connector	Go to step 4.
4	<p><b>CHECK OUTPUT SIGNAL FROM ECM.</b>                      1) Start and idle the engine.                      2) Measure voltage between ECM connector and chassis ground.  <b>Connector &amp; terminal</b>  <b>(B134) No. 21 (+) — Chassis ground (-):</b></p>	Is the voltage less than 1.0 V?	Go to step 7.	Go to step 5.
5	<p><b>CHECK OUTPUT SIGNAL FROM ECM.</b>                      Measure voltage between ECM connector and chassis ground.  <b>Connector &amp; terminal</b>  <b>(B134) No. 21 (+) — Chassis ground (-):</b></p>	Does the voltage change less than 1.0 V by shaking harness and connector of ECM while monitoring the value with voltage meter?	Repair poor contact in ECM connector.	Go to step 6.
6	<p><b>CHECK OUTPUT SIGNAL FROM ECM.</b>                      1) Disconnect connector from rear oxygen sensor.                      2) Measure voltage between ECM connector and chassis ground.  <b>Connector &amp; terminal</b>  <b>(B134) No. 21 (+) — Chassis ground (-):</b></p>	Is the voltage less than 1.0 V?	Replace ECM. <Ref. to FU(SOHC)-49, Engine Control Module.>	Repair battery short circuit in harness between ECM and rear oxygen sensor connector. After repair, replace ECM. <Ref. to FU(SOHC)-49, Engine Control Module.>

# DIAGNOSTIC PROCEDURE WITH DIAGNOSTIC TROUBLE CODE (DTC)

Engine (Diagnostics)

No.	Step	Check	Yes	No
7	<p><b>CHECK POWER SUPPLY TO REAR OXYGEN SENSOR.</b></p> <p>1) Turn ignition switch to OFF.                      2) Disconnect connector from rear oxygen sensor.                      3) Turn ignition switch to ON.                      4) Measure voltage between rear oxygen sensor connector and engine ground or chassis ground.</p> <p><b>Connector &amp; terminal</b>  <b>(E25) No. 2 (+) — Chassis ground (-):</b></p>	<p>Is the voltage more than 10 V?</p>	<p>Go to step 8.</p>	<p>Repair power supply line.                      NOTE:                      In this case, repair the following:</p> <ul style="list-style-type: none"> <li>● Open circuit in harness between main relay and rear oxygen sensor connector</li> <li>● Poor contact in rear oxygen sensor connector</li> <li>● Poor contact in coupling connector (E1)</li> </ul>
8	<p><b>CHECK REAR OXYGEN SENSOR.</b></p> <p>1) Turn ignition switch to OFF.                      2) Measure resistance between rear oxygen sensor connector terminals.</p> <p><b>Terminals</b>  <b>No. 1 — No. 2:</b></p>	<p>Is the resistance less than 30 Ω?</p>	<p>Repair harness and connector.                      NOTE:                      In this case, repair the following:</p> <ul style="list-style-type: none"> <li>● Open circuit in harness between rear oxygen sensor and ECM connector</li> <li>● Poor contact in rear oxygen sensor connector</li> <li>● Poor contact in ECM connector</li> <li>● Poor contact in coupling connector (E1)</li> </ul>	<p>Replace rear oxygen sensor. &lt;Ref. to FU(SOHC)-47, Rear Oxygen Sensor.&gt;</p>

**MEMO:**

# DIAGNOSTIC PROCEDURE WITH DIAGNOSTIC TROUBLE CODE (DTC)

Engine (Diagnostics)

## D: DTC P0038 — REAR OXYGEN SENSOR HEATER CIRCUIT HIGH INPUT —

S058521F86

### • DTC DETECTING CONDITION:

- Two consecutive driving cycles with fault

### CAUTION:

After repair or replacement of faulty parts, conduct Clear Memory Mode <Ref. to EN(SOHC)-45, OPERATION, Clear Memory Mode.> and Inspection Mode <Ref. to EN(SOHC)-42, OPERATION, Inspection Mode.>.

### • WIRING DIAGRAM:

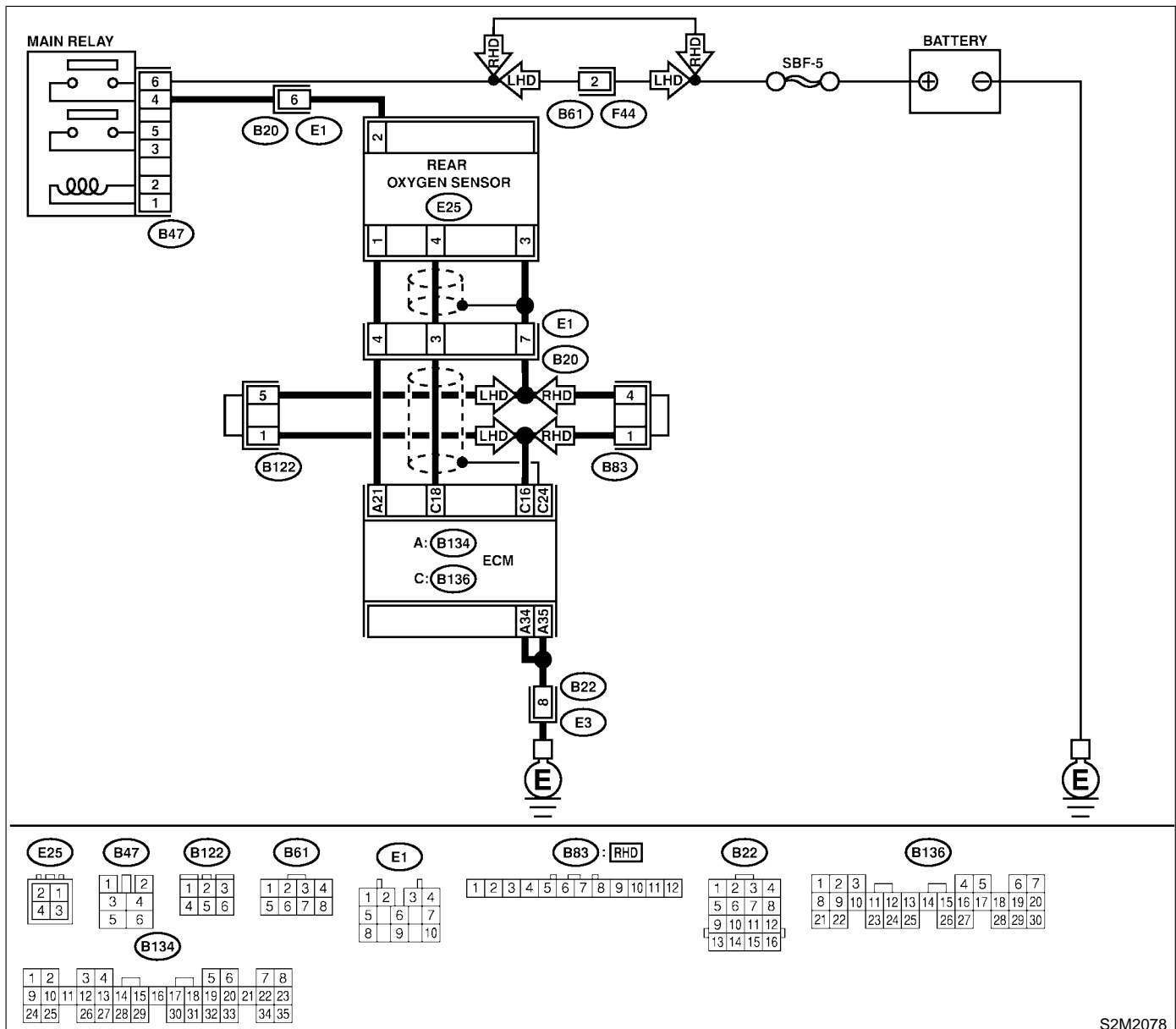

S2M2078

No.	Step	Check	Yes	No
1	<b>CHECK INPUT SIGNAL FOR ECM.</b> Measure voltage between ECM connector and chassis ground. <b>Connector &amp; terminal</b> (B134) No. 21 (+) — Chassis ground (-):	Is the voltage more than 8 V?	Go to step 2.	Go to step 3.



# DIAGNOSTIC PROCEDURE WITH DIAGNOSTIC TROUBLE CODE (DTC)

Engine (Diagnostics)

No.	Step	Check	Yes	No
2	<p><b>CHECK CURRENT DATA.</b></p> <p>1) Turn ignition switch to OFF. 2) Repair battery short circuit in harness between ECM and rear oxygen sensor connector. 3) Turn ignition switch to ON. 4) Read data of rear oxygen sensor heater current using Subaru Select Monitor or the OBD-II general scan tool.</p> <p>NOTE:</p> <ul style="list-style-type: none"><li>● Subaru Select Monitor For detailed operation procedure, refer to the "READ CURRENT DATA FOR ENGINE". &lt;Ref. to EN(SOHC)-34, Subaru Select Monitor.&gt;</li><li>● OBD-II general scan tool For detailed operation procedure, refer to the OBD-II General Scan Tool Instruction Manual.</li></ul>	Is the value more than 7 A?	Replace ECM. <Ref. to FU(SOHC)-49, Engine Control Module.>	END
3	<p><b>CHECK POOR CONTACT.</b></p> <p>Check poor contact in ECM connector.</p>	Is there poor contact in ECM connector?	Repair poor contact in ECM connector.	END

# DIAGNOSTIC PROCEDURE WITH DIAGNOSTIC TROUBLE CODE (DTC)

Engine (Diagnostics)

## E: DTC P0066 — AIR ASSIST INJECTOR SOLENOID VALVE CIRCUIT LOW INPUT — S058521F88

- **DTC DETECTING CONDITION:**
  - Immediately at fault recognition
- **TROUBLE SYMPTOM:**
  - Erroneous idling
  - Engine stalls.

### CAUTION:

After repair or replacement of faulty parts, conduct Clear Memory Mode <Ref. to EN(SOHC)-45, OPERATION, Clear Memory Mode.> and Inspection Mode <Ref. to EN(SOHC)-42, OPERATION, Inspection Mode.>.

- **WIRING DIAGRAM:**

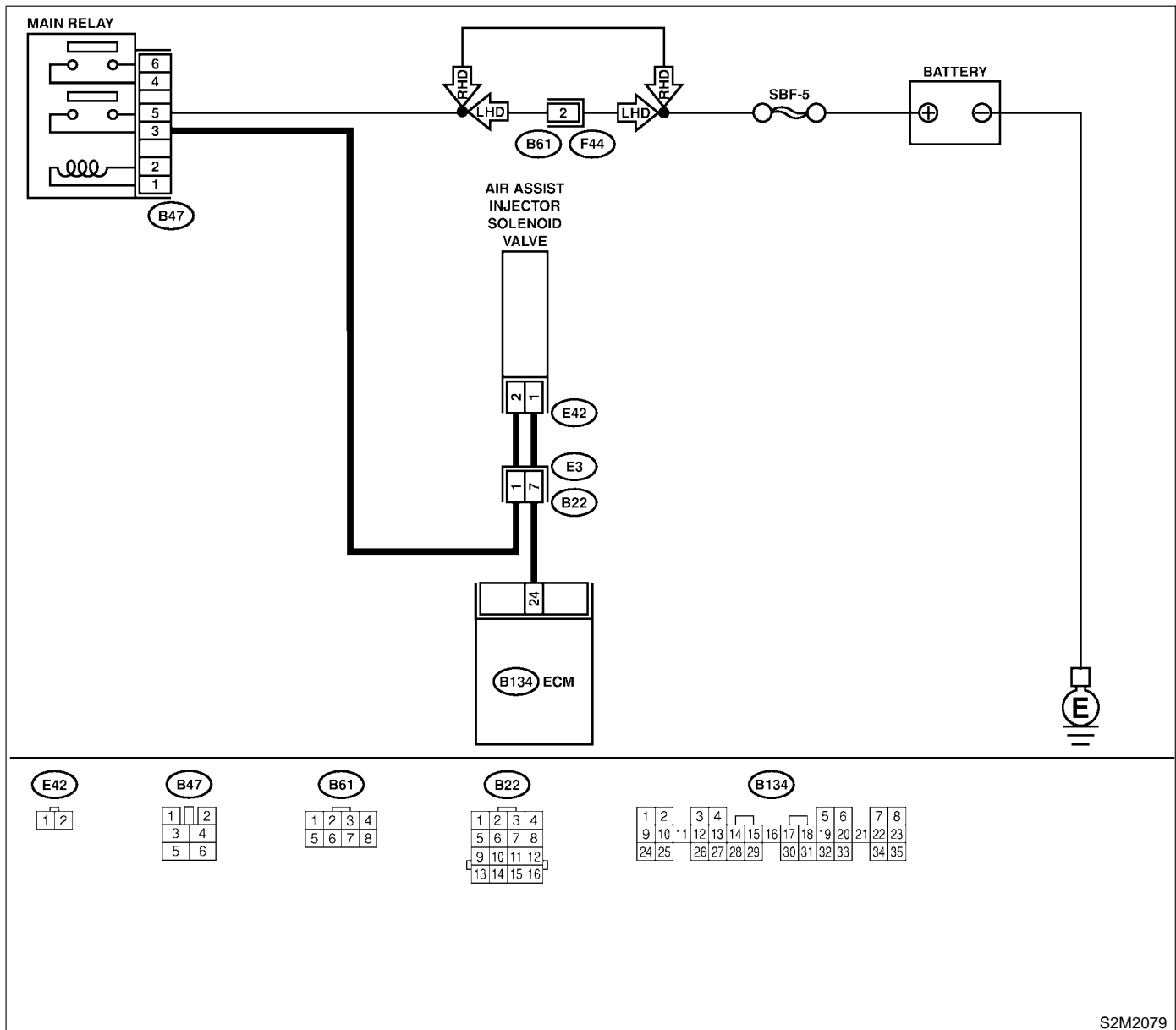

S2M2079

# DIAGNOSTIC PROCEDURE WITH DIAGNOSTIC TROUBLE CODE (DTC)

Engine (Diagnostics)

No.	Step	Check	Yes	No
1	<p><b>CHECK OUTPUT SIGNAL FROM ECM.</b>                      1) Turn ignition switch to ON.                      2) Measure voltage between ECM and chassis ground.  <b>Connector &amp; terminal</b>  <i>(B134) No. 24 (+) — Chassis ground (-):</i></p>	Is the voltage more than 10 V?	Repair poor contact in ECM connector.	Go to step 2.
2	<p><b>CHECK POWER SUPPLY TO AIR ASSIST INJECTOR SOLENOID VALVE.</b>                      1) Turn ignition switch to OFF.                      2) Disconnect connector from air assist injector solenoid valve.                      3) Turn ignition switch to ON.                      4) Measure voltage between air assist injector solenoid valve and engine ground.  <b>Connector &amp; terminal</b>  <i>(E42) No. 2 (+) — Engine ground (-):</i></p>	Is the voltage more than 10 V?	Go to step 3.	Repair harness and connector. NOTE: In this case, repair the following: <ul style="list-style-type: none"> <li>● Open circuit in harness between air assist injector solenoid valve and main relay connector</li> <li>● Poor contact in coupling connector (B22)</li> </ul>
3	<p><b>CHECK HARNESS BETWEEN ECM AND AIR ASSIST INJECTOR SOLENOID VALVE CONNECTOR.</b>                      1) Turn ignition switch to OFF.                      2) Disconnect connector from ECM.                      3) Measure resistance of harness between ECM and air assist injector solenoid valve connector.  <b>Connector &amp; terminal</b>  <i>(B134) No. 24 — (E42) No. 1:</i></p>	Is the resistance less than 1 $\Omega$ ?	Go to step 4.	Repair harness and connector. NOTE: In this case, repair the following: <ul style="list-style-type: none"> <li>● Open circuit in harness between ECM and air assist injector solenoid valve connector</li> <li>● Poor contact in coupling connector (B22)</li> </ul>
4	<p><b>CHECK HARNESS BETWEEN ECM AND AIR ASSIST INJECTOR SOLENOID VALVE CONNECTOR.</b>                      Measure resistance of harness between ECM and chassis ground.  <b>Connector &amp; terminal</b>  <i>(B134) No. 24 — Chassis ground:</i></p>	Is the resistance less than 10 $\Omega$ ?	Repair ground short circuit in harness between ECM and air assist injector solenoid valve connector.	Go to step 5.
5	<p><b>CHECK POOR CONTACT.</b>                      Check poor contact in ECM and air assist injector solenoid valve connectors.</p>	Is there poor contact in ECM and air assist injector solenoid valve connectors?	Repair poor contact in ECM and air assist injector solenoid valve connectors.	Replace air assist injector solenoid valve. <Ref. to FU(SOHC)-39, Air Assist Injector Solenoid Valve.>

# DIAGNOSTIC PROCEDURE WITH DIAGNOSTIC TROUBLE CODE (DTC)

Engine (Diagnostics)

## F: DTC P0067 — AIR ASSIST INJECTOR SOLENOID VALVE CIRCUIT HIGH INPUT — S058521G72

- **DTC DETECTING CONDITION:**
  - Immediately at fault recognition
- **TROUBLE SYMPTOM:**
  - Erroneous idling
  - Engine stalls.

### CAUTION:

After repair or replacement of faulty parts, conduct Clear Memory Mode <Ref. to EN(SOHC)-45, OPERATION, Clear Memory Mode.> and Inspection Mode <Ref. to EN(SOHC)-42, OPERATION, Inspection Mode.>.

- **WIRING DIAGRAM:**

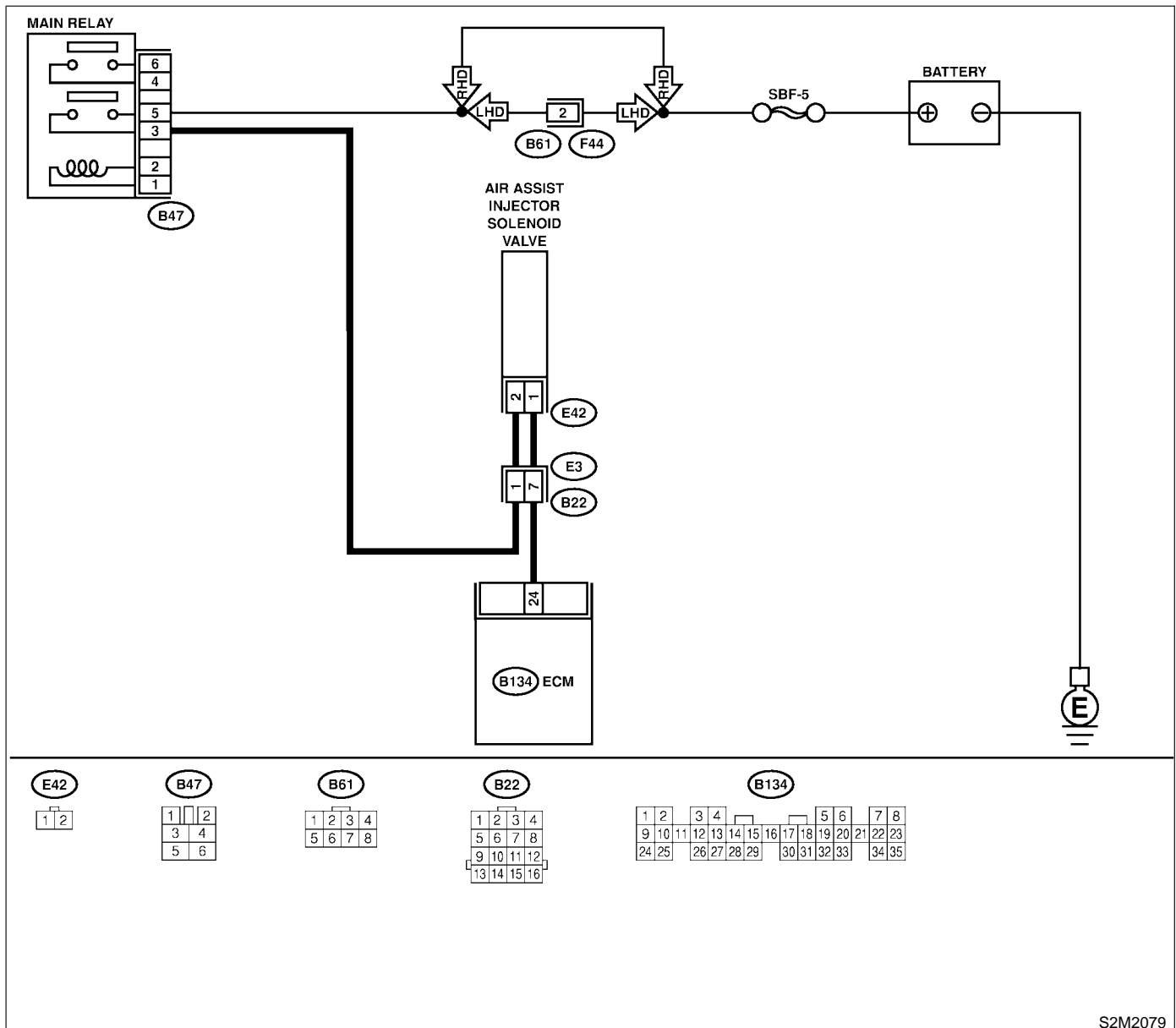

# DIAGNOSTIC PROCEDURE WITH DIAGNOSTIC TROUBLE CODE (DTC)

Engine (Diagnostics)

No.	Step	Check	Yes	No
1	<p><b>CHECK OUTPUT SIGNAL FROM ECM.</b>                      1) Turn ignition switch to ON.                      2) Measure voltage between ECM and chassis ground.  <b>Connector &amp; terminal</b>  <b>(B134) No. 24 (+) — Chassis ground (-):</b></p>	Is the voltage more than 10 V?	Go to step 2.	Go to step 3.
2	<p><b>CHECK OUTPUT SIGNAL FROM ECM.</b>                      1) Turn ignition switch to OFF.                      2) Disconnect connector from air assist injector solenoid valve.                      3) Turn ignition switch to ON.                      4) Measure voltage between ECM and chassis ground.  <b>Connector &amp; terminal</b>  <b>(B134) No. 24 (+) — Chassis ground (-):</b></p>	Is the voltage more than 10 V?	Repair battery short circuit in harness between ECM and air assist injector solenoid valve connector. After repair, replace ECM. <Ref. to FU(SOHC)-49, Engine Control Module.>	Replace air assist injector solenoid valve <Ref. to FU(SOHC)-39, Air Assist Injector Solenoid Valve.> and ECM <Ref. to FU(SOHC)-49, Engine Control Module.>
3	<p><b>CHECK OUTPUT SIGNAL FROM ECM.</b>                      Measure voltage between ECM and chassis ground.  <b>Connector &amp; terminal</b>  <b>(B134) No. 24 (+) — Chassis ground (-):</b></p>	Does the voltage change more than 10 V by shaking harness and connector of ECM while monitoring the value with voltage meter?	Repair battery short circuit in harness between ECM and air assist injector solenoid valve connector. After repair, replace ECM. <Ref. to FU(SOHC)-49, Engine Control Module.>	Contact your Subaru distributor. NOTE: Inspection by DTM is required, because probable cause is deterioration of multiple parts.

# DIAGNOSTIC PROCEDURE WITH DIAGNOSTIC TROUBLE CODE (DTC)

Engine (Diagnostics)

## G: DTC P0106 — PRESSURE SENSOR CIRCUIT RANGE/PERFORMANCE PROBLEM (LOW INPUT) — S058521F90

### • DTC DETECTING CONDITION:

- Two consecutive driving cycles with fault

### CAUTION:

After repair or replacement of faulty parts, conduct Clear Memory Mode <Ref. to EN(SOHC)-45, OPERATION, Clear Memory Mode.> and Inspection Mode <Ref. to EN(SOHC)-42, OPERATION, Inspection Mode.>.

### • WIRING DIAGRAM:

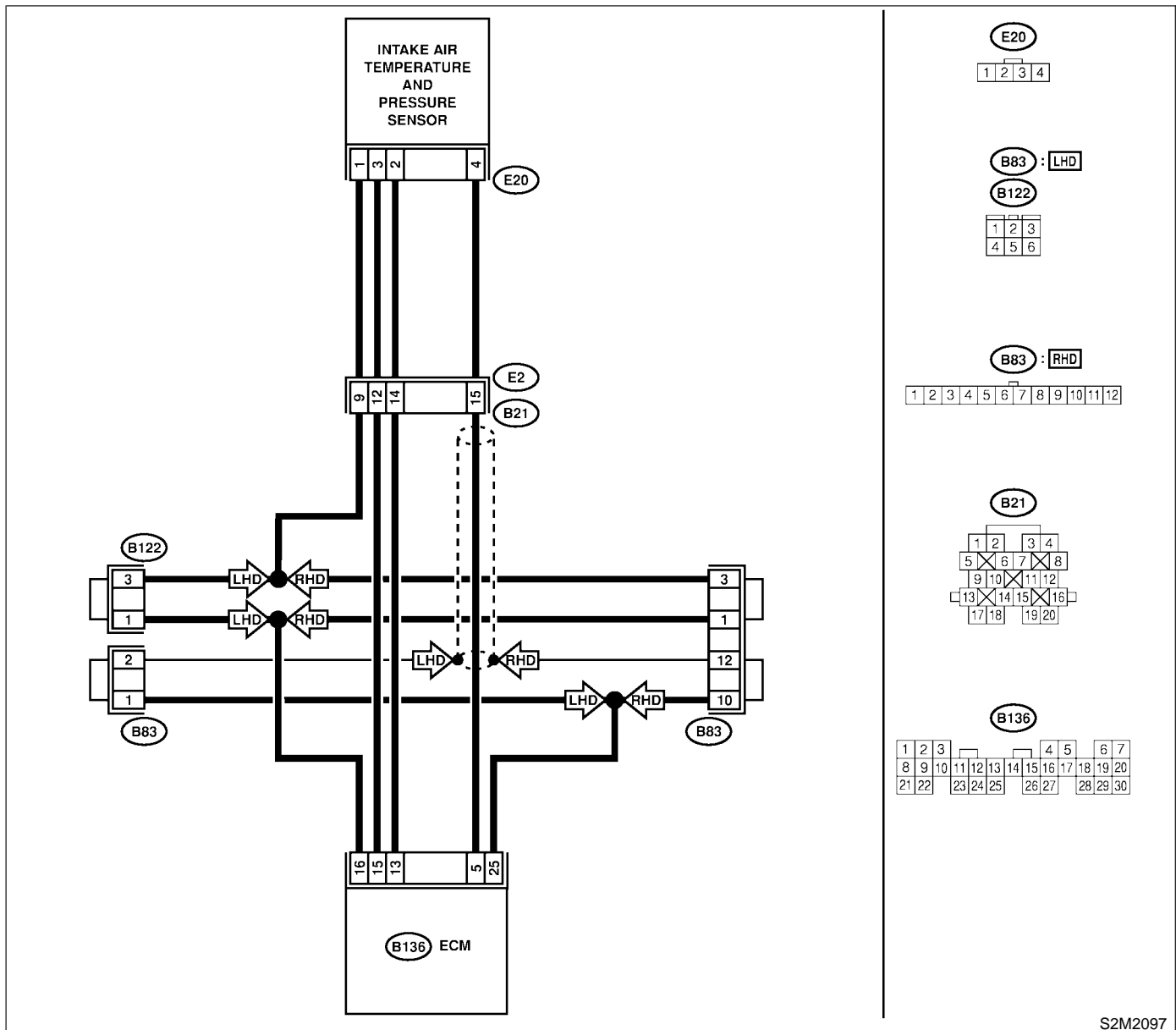

S2M2097

# DIAGNOSTIC PROCEDURE WITH DIAGNOSTIC TROUBLE CODE (DTC)

Engine (Diagnostics)

No.	Step	Check	Yes	No
1	<p><b>CHECK ANY OTHER DTC ON DISPLAY.</b></p> <p>NOTE: In this case, it is not necessary to inspect DTC P0106.</p>	Does the Subaru Select Monitor or OBD-II general scan tool indicate DTC P0107, P0108 or P1112?	Inspect DTC P0107, P0108 or P1112 using "17. List of Diagnostic Trouble Code (DTC)". <Ref. to EN(SOHC)-80, List of Diagnostic Trouble Code (DTC).>	Go to step 2.
2	<p><b>CHECK AIR INTAKE SYSTEM.</b></p>	Are there holes, loose bolts or disconnection of hose on air intake system?	Repair air intake system.	Go to step 3.
3	<p><b>CHECK PRESSURE SENSOR.</b></p> <p>1) Start the engine and warm-up engine until coolant temperature is greater than 60°C (140°F). 2) Place the shift lever in the selector lever in "N" or "P" position. 3) Turn A/C switch to OFF. 4) Turn all accessory switches to OFF. 5) Read data of intake manifold pressure sensor signal using Subaru Select Monitor or OBD-II general scan tool.</p> <p>NOTE:</p> <ul style="list-style-type: none"> <li>Subaru Select Monitor For detailed operation procedure, refer to the "READ CURRENT DATA FOR ENGINE". &lt;Ref. to EN(SOHC)-34, Subaru Select Monitor.&gt;</li> <li>OBD-II general scan tool For detailed operation procedure, refer to the OBD-II General Scan Tool Instruction Manual.</li> </ul> <p>Specification:</p> <ul style="list-style-type: none"> <li>Intake manifold absolute pressure</li> </ul> <p><b>Ignition ON</b> 73.3 — 106.6 kPa (550 — 800 mmHg, 21.65 — 31.50 inHg)</p> <p><b>Idling</b> 20.0 — 46.7 kPa (150 — 350 mmHg, 5.91 — 13.78 inHg)</p>	Is the value within the specifications?	Go to step 4.	Replace intake air temperature sensor and pressure sensor. <Ref. to FU(SOHC)-36, Intake Air Temperature and Pressure Sensor.>
4	<p><b>CHECK THROTTLE POSITION.</b></p> <p>Read data of throttle position signal using Subaru Select Monitor or OBD-II general scan tool.</p> <p>NOTE:</p> <ul style="list-style-type: none"> <li>Subaru Select Monitor For detailed operation procedure, refer to the "READ CURRENT DATA FOR ENGINE". &lt;Ref. to EN(SOHC)-34, Subaru Select Monitor.&gt;</li> <li>OBD-II general scan tool For detailed operation procedure, refer to the OBD-II General Scan Tool Instruction Manual.</li> </ul>	Is throttle positioning ratio equal to or less than 5% when throttle is fully closed?	Go to step 5.	Adjust or replace throttle position sensor. <Ref. to FU(SOHC)-33 Throttle Position Sensor.>

# DIAGNOSTIC PROCEDURE WITH DIAGNOSTIC TROUBLE CODE (DTC)

Engine (Diagnostics)

No.	Step	Check	Yes	No
5	CHECK THROTTLE POSITION.	Is throttle positioning ratio equal to or more than 85% when throttle is fully open?	Replace intake air temperature and pressure sensor. <Ref. to FU(SOHC)-36, Intake Air Temperature and Pressure Sensor.>	Replace throttle position sensor. <Ref. to FU(SOHC)-33, Throttle Position Sensor.>



**MEMO:**

# DIAGNOSTIC PROCEDURE WITH DIAGNOSTIC TROUBLE CODE (DTC)

Engine (Diagnostics)

## H: DTC P0107 — PRESSURE SENSOR CIRCUIT LOW INPUT — S058521B12

- DTC DETECTING CONDITION:
  - Immediately at fault recognition

### CAUTION:

After repair or replacement of faulty parts, conduct Clear Memory Mode <Ref. to EN(SOHC)-45, OPERATION, Clear Memory Mode.> and Inspection Mode <Ref. to EN(SOHC)-42, OPERATION, Inspection Mode.>.

### ● WIRING DIAGRAM:

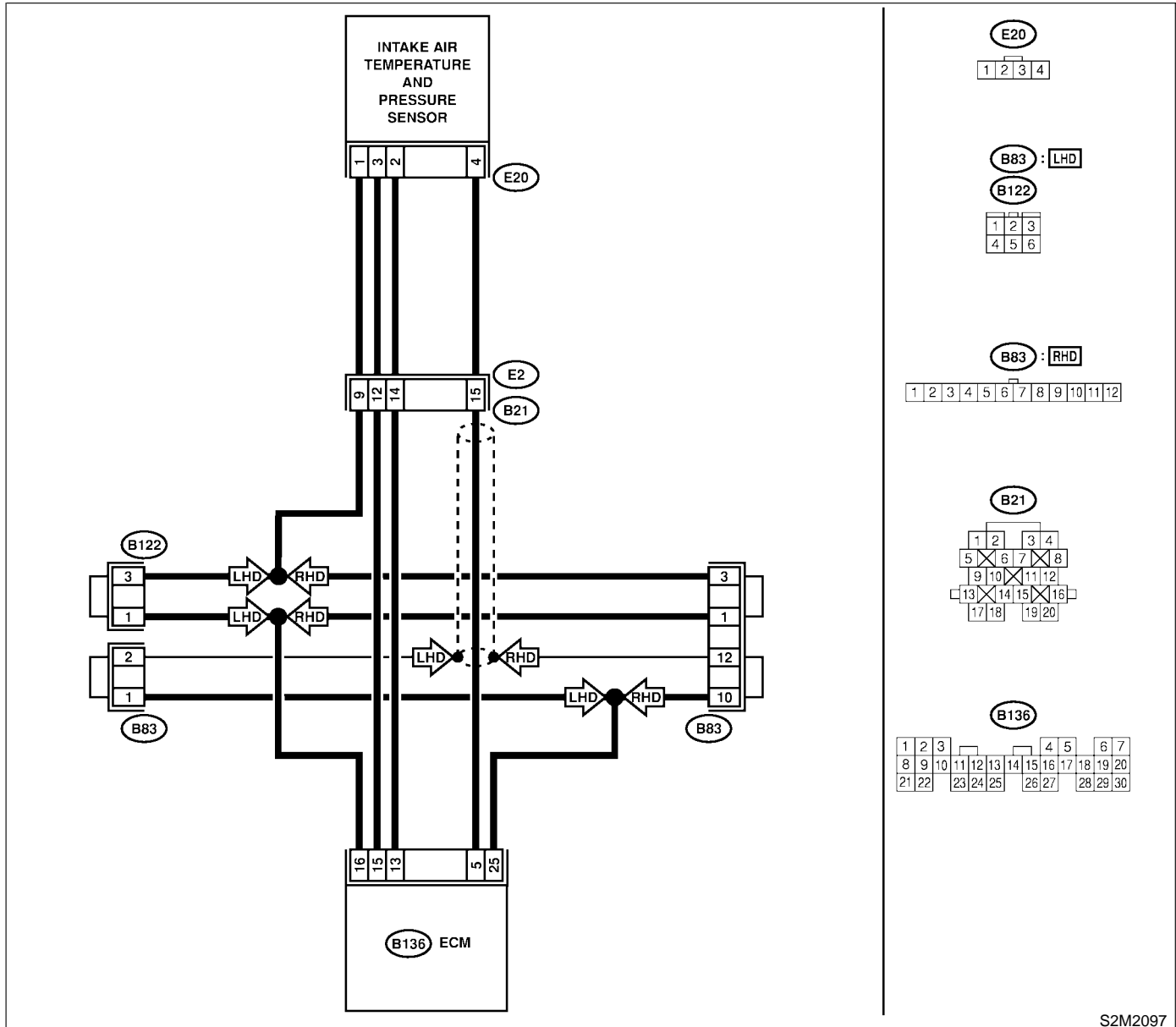

S2M2097

# DIAGNOSTIC PROCEDURE WITH DIAGNOSTIC TROUBLE CODE (DTC)

Engine (Diagnostics)

No.	Step	Check	Yes	No
1	<p><b>CHECK CURRENT DATA.</b>                      1) Start engine.                      2) Read the data of intake manifold absolute pressure signal using Subaru Select Monitor or OBD-II general scan tool.                      NOTE:                      ● Subaru Select Monitor                      For detailed operation procedure, refer to the "READ CURRENT DATA FOR ENGINE".                      &lt;Ref. to EN(SOHC)-34, Subaru Select Monitor.&gt;                      ● OBD-II general scan tool                      For detailed operation procedures, refer to the OBD-II General Scan Tool Instruction Manual.</p>	Is the value less than 13.3 kPa (100 mmHg, 3.94 inHg)?	Go to step 3.	Go to step 2.
2	<p><b>CHECK POOR CONTACT.</b>                      Check poor contact in ECM and pressure sensor connector.</p>	Is there poor contact in ECM or pressure sensor connector?	Repair poor contact in ECM or pressure sensor connector.	Even if MIL lights up, the circuit has returned to a normal condition at this time.
3	<p><b>CHECK INPUT SIGNAL FOR ECM.</b>                      Measure voltage between ECM connector and chassis ground.  <i>Connector &amp; terminal</i>  <i>(B136) No. 15 (+) — Chassis ground (-):</i></p>	Is the voltage more than 4.5 V?	Go to step 5.	Go to step 4.
4	<p><b>CHECK INPUT SIGNAL FOR ECM.</b>                      Measure voltage between ECM connector and chassis ground.  <i>Connector &amp; terminal</i>  <i>(B136) No. 15 (+) — Chassis ground (-):</i></p>	Does the voltage change more than 4.5 V by shaking harness and connector of ECM while monitoring the value with voltage meter?	Repair poor contact in ECM connector.	Contact your Subaru distributor. NOTE: Inspection by DTM is required, because probable cause is deterioration of multiple parts.
5	<p><b>CHECK INPUT SIGNAL FOR ECM.</b>                      Measure voltage between ECM and chassis ground.  <i>Connector &amp; terminal</i>  <i>(B136) No. 5 (+) — Chassis ground (-):</i></p>	Is the voltage less than 0.2 V?	Go to step 7.	Go to step 6.
6	<p><b>CHECK INPUT SIGNAL FOR ECM. (USING SUBARU SELECT MONITOR.)</b>                      Read data of atmospheric absolute pressure signal using Subaru Select Monitor.                      NOTE:                      ● Subaru Select Monitor                      For detailed operation procedure, refer to the "READ CURRENT DATA FOR ENGINE".                      &lt;Ref. to EN(SOHC)-34, Subaru Select Monitor.&gt;</p>	Does the value change more than 13.3 kPa (100 mmHg, 3.94 inHg) by shaking harness and connector of ECM while monitoring the value with Subaru Select Monitor?	Repair poor contact in ECM connector.	Go to step 7.

# DIAGNOSTIC PROCEDURE WITH DIAGNOSTIC TROUBLE CODE (DTC)

Engine (Diagnostics)

No.	Step	Check	Yes	No
7	<p><b>CHECK HARNESS BETWEEN ECM AND INTAKE AIR TEMPERATURE AND PRESSURE SENSOR CONNECTOR.</b></p> <p>1) Turn ignition switch to OFF. 2) Disconnect connector from intake air temperature and pressure sensor. 3) Turn ignition switch to ON. 4) Measure voltage between intake air temperature sensor and pressure sensor connector and engine ground.</p> <p><b>Connector &amp; terminal</b> <b>(E20) No. 3 (+) — Engine ground (-):</b></p>	Is the voltage more than 4.5 V?	Go to step 8.	Repair open circuit in harness between ECM and intake air temperature and pressure sensor connector.
8	<p><b>CHECK HARNESS BETWEEN ECM AND INTAKE AIR TEMPERATURE AND PRESSURE SENSOR CONNECTOR.</b></p> <p>1) Turn ignition switch to OFF. 2) Disconnect connector from ECM. 3) Measure resistance of harness between ECM and intake air temperature and pressure sensor connector.</p> <p><b>Connector &amp; terminal</b> <b>(B136) No. 16 — (E20) No. 1:</b></p>	Is the resistance less than 1 Ω?	Go to step 9.	Repair open circuit in harness between ECM and intake air temperature and pressure sensor connector.
9	<p><b>CHECK HARNESS BETWEEN ECM AND INTAKE AIR TEMPERATURE AND PRESSURE SENSOR CONNECTOR.</b></p> <p>Measure resistance of harness between intake air temperature and pressure sensor connector and engine ground.</p> <p><b>Connector &amp; terminal</b> <b>(E20) No. 4 — Engine ground:</b></p>	Is the resistance more than 500 kΩ?	Go to step 10.	Repair ground short circuit in harness between ECM and intake air temperature and pressure sensor connector.
10	<p><b>CHECK POOR CONTACT.</b></p> <p>Check poor contact in intake manifold pressure sensor connector.</p>	Is there poor contact in intake manifold pressure sensor connector?	Repair poor contact in intake air temperature and pressure sensor connector.	Replace intake air temperature and pressure sensor. <Ref. to FU(SOHC)-36, Intake Air Temperature and Pressure Sensor.>

**MEMO:**

# DIAGNOSTIC PROCEDURE WITH DIAGNOSTIC TROUBLE CODE (DTC)

Engine (Diagnostics)

## I: DTC P0108 — PRESSURE SENSOR CIRCUIT HIGH INPUT — S058521B13

- DTC DETECTING CONDITION:
  - Immediately at fault recognition

### CAUTION:

After repair or replacement of faulty parts, conduct Clear Memory Mode <Ref. to EN(SOHC)-45, OPERATION, Clear Memory Mode.> and Inspection Mode <Ref. to EN(SOHC)-42, OPERATION, Inspection Mode.>.

### ● WIRING DIAGRAM:

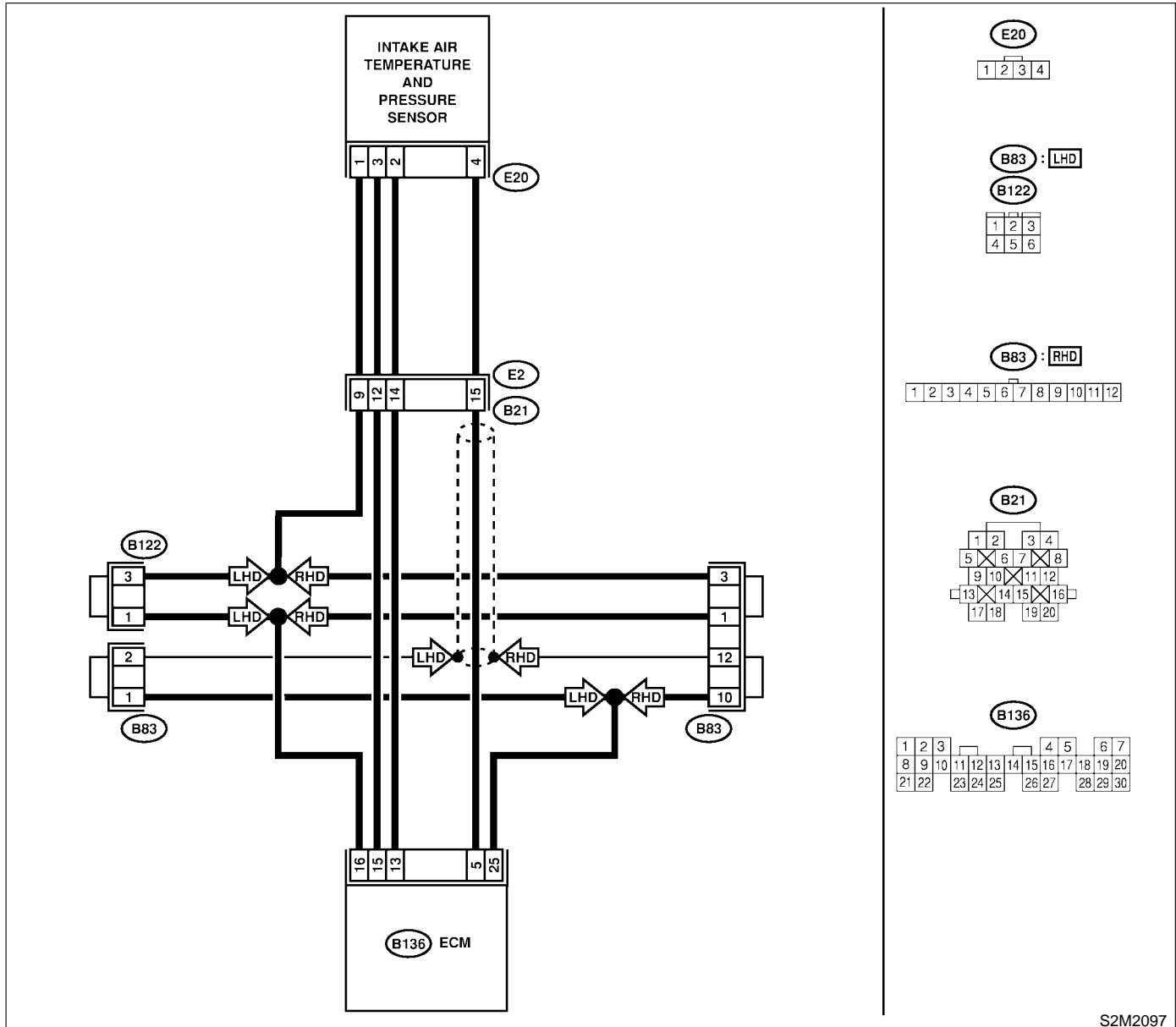

S2M2097

# DIAGNOSTIC PROCEDURE WITH DIAGNOSTIC TROUBLE CODE (DTC)

Engine (Diagnostics)

No.	Step	Check	Yes	No
1	<p><b>CHECK CURRENT DATA.</b>                      1) Start engine.                      2) Read the data of intake manifold absolute pressure signal using Subaru Select Monitor or OBD-II general scan tool.                      NOTE:                      ● Subaru Select Monitor                      For detailed operation procedure, refer to the "READ CURRENT DATA FOR ENGINE".                      &lt;Ref. to EN(SOHC)-34, Subaru Select Monitor.&gt;                      ● OBD-II general scan tool                      For detailed operation procedures, refer to the OBD-II General Scan Tool Instruction Manual.</p>	Is the value more than 119.5 kPa (896.5 mmHg, 35.29 inHg)?	Go to step 10.	Go to step 2.
2	<p><b>CHECK INPUT SIGNAL FOR ECM.</b>                      Measure voltage between ECM connector and chassis ground.  <b>Connector &amp; terminal</b>  <b>(B136) No. 15 (+) — Chassis ground (-):</b></p>	Is the voltage more than 4.5 V?	Go to step 4.	Go to step 3.
3	<p><b>CHECK INPUT SIGNAL FOR ECM.</b>                      Measure voltage between ECM connector and chassis ground.  <b>Connector &amp; terminal</b>  <b>(B136) No. 15 (+) — Chassis ground (-):</b></p>	Does the voltage change more than 4.5 V by shaking harness and connector of ECM while monitoring the value with voltage meter?	Repair poor contact in ECM connector.	Contact your Subaru distributor. NOTE: Inspection by DTM is required, because probable cause is deterioration of multiple parts.
4	<p><b>CHECK INPUT SIGNAL FOR ECM.</b>                      Measure voltage between ECM connector and chassis ground.  <b>Connector &amp; terminal</b>  <b>(B136) No. 5 (+) — Chassis ground (-):</b></p>	Is the voltage less than 0.2 V?	Go to step 6.	Go to step 5.
5	<p><b>CHECK INPUT SIGNAL FOR ECM. (USING SUBARU SELECT MONITOR.)</b>                      Read data of atmospheric absolute pressure signal using Subaru Select Monitor.                      NOTE:                      ● Subaru Select Monitor                      For detailed operation procedure, refer to the "READ CURRENT DATA FOR ENGINE".                      &lt;Ref. to EN(SOHC)-34, Subaru Select Monitor.&gt;</p>	Does the value change more than 13.3 kPa (100 mmHg, 3.94 inHg) by shaking harness and connector of ECM while monitoring the value with Subaru Select Monitor?	Repair poor contact in ECM connector.	Go to step 6.
6	<p><b>CHECK HARNESS BETWEEN ECM AND INTAKE AIR TEMPERATURE AND PRESSURE SENSOR CONNECTOR.</b>                      1) Turn ignition switch to OFF.                      2) Disconnect connector from intake air temperature and pressure sensor.                      3) Turn ignition switch to ON.                      4) Measure voltage between intake air temperature and pressure sensor connector and engine ground.  <b>Connector &amp; terminal</b>  <b>(E20) No. 3 (+) — Engine ground (-):</b></p>	Is the voltage more than 4.5 V?	Go to step 7.	Repair open circuit in harness between ECM and intake air temperature and pressure sensor connector.

# DIAGNOSTIC PROCEDURE WITH DIAGNOSTIC TROUBLE CODE (DTC)

Engine (Diagnostics)

No.	Step	Check	Yes	No
7	<p><b>CHECK HARNESS BETWEEN ECM AND INTAKE AIR TEMPERATURE AND PRESSURE SENSOR CONNECTOR.</b></p> <p>1) Turn ignition switch to OFF. 2) Disconnect connector from ECM. 3) Measure resistance of harness between ECM and intake air temperature and pressure sensor connector.</p> <p><b>Connector &amp; terminal</b> <b>(B136) No. 5 — (E20) No. 4:</b></p>	Is the resistance less than 1 Ω?	Go to step 8.	Repair open circuit in harness between ECM and intake air temperature and pressure sensor connector.
8	<p><b>CHECK HARNESS BETWEEN ECM AND INTAKE AIR TEMPERATURE AND PRESSURE SENSOR CONNECTOR.</b></p> <p>Measure resistance of harness between ECM and intake air temperature and pressure sensor connector.</p> <p><b>Connector &amp; terminal</b> <b>(B136) No. 16 — (E20) No. 1:</b></p>	Is the resistance less than 1 Ω?	Go to step 9.	Repair open circuit in harness between ECM and intake air temperature and pressure sensor connector.
9	<p><b>CHECK POOR CONTACT.</b></p> <p>Check poor contact in intake air temperature and pressure sensor connector.</p>	Is there poor contact in intake manifold pressure sensor connector?	Repair poor contact in intake air temperature and pressure sensor connector.	Replace intake air temperature and pressure sensor. <Ref. to FU(SOHC)-36, Intake Air Temperature and Pressure Sensor.>
10	<p><b>CHECK HARNESS BETWEEN ECM AND INTAKE AIR TEMPERATURE AND PRESSURE SENSOR CONNECTOR.</b></p> <p>1) Turn ignition switch to OFF and Subaru Select Monitor or the OBD-II general scan tool switch to OFF. 2) Disconnect connector from intake air temperature and pressure sensor. 3) Turn ignition switch to ON and Subaru Select Monitor or the OBD-II general scan tool switch to ON. 4) Read data of intake manifold absolute pressure signal using Subaru Select Monitor or OBD-II general scan tool.</p> <p>NOTE:</p> <ul style="list-style-type: none"> <li>● Subaru Select Monitor For detailed operation procedure, refer to the "READ CURRENT DATA FOR ENGINE". &lt;Ref. to EN(SOHC)-34, Subaru Select Monitor.&gt;</li> <li>● OBD-II general scan tool For detailed operation procedures, refer to the OBD-II General Scan Tool Instruction Manual.</li> </ul>	Is the value more than 119.5 kPa (896.5 mmHg, 35.29 inHg)?	Repair battery short circuit in harness between ECM and intake air temperature and pressure sensor connector.	Replace intake air temperature and pressure sensor. <Ref. to FU(SOHC)-36, Intake Air Temperature and Pressure Sensor.>



**MEMO:**

# DIAGNOSTIC PROCEDURE WITH DIAGNOSTIC TROUBLE CODE (DTC)

Engine (Diagnostics)

## J: DTC P0111 — INTAKE AIR TEMPERATURE SENSOR CIRCUIT RANGE/PERFORMANCE PROBLEM —

S058521B14

- **DTC DETECTING CONDITION:**
  - Immediately at fault recognition
- **TROUBLE SYMPTOM:**
  - Erroneous idling
  - Poor driving performance

### CAUTION:

After repair or replacement of faulty parts, conduct Clear Memory Mode <Ref. to EN(SOHC)-45, OPERATION, Clear Memory Mode.> and Inspection Mode <Ref. to EN(SOHC)-42, OPERATION, Inspection Mode.>.

### ● WIRING DIAGRAM:

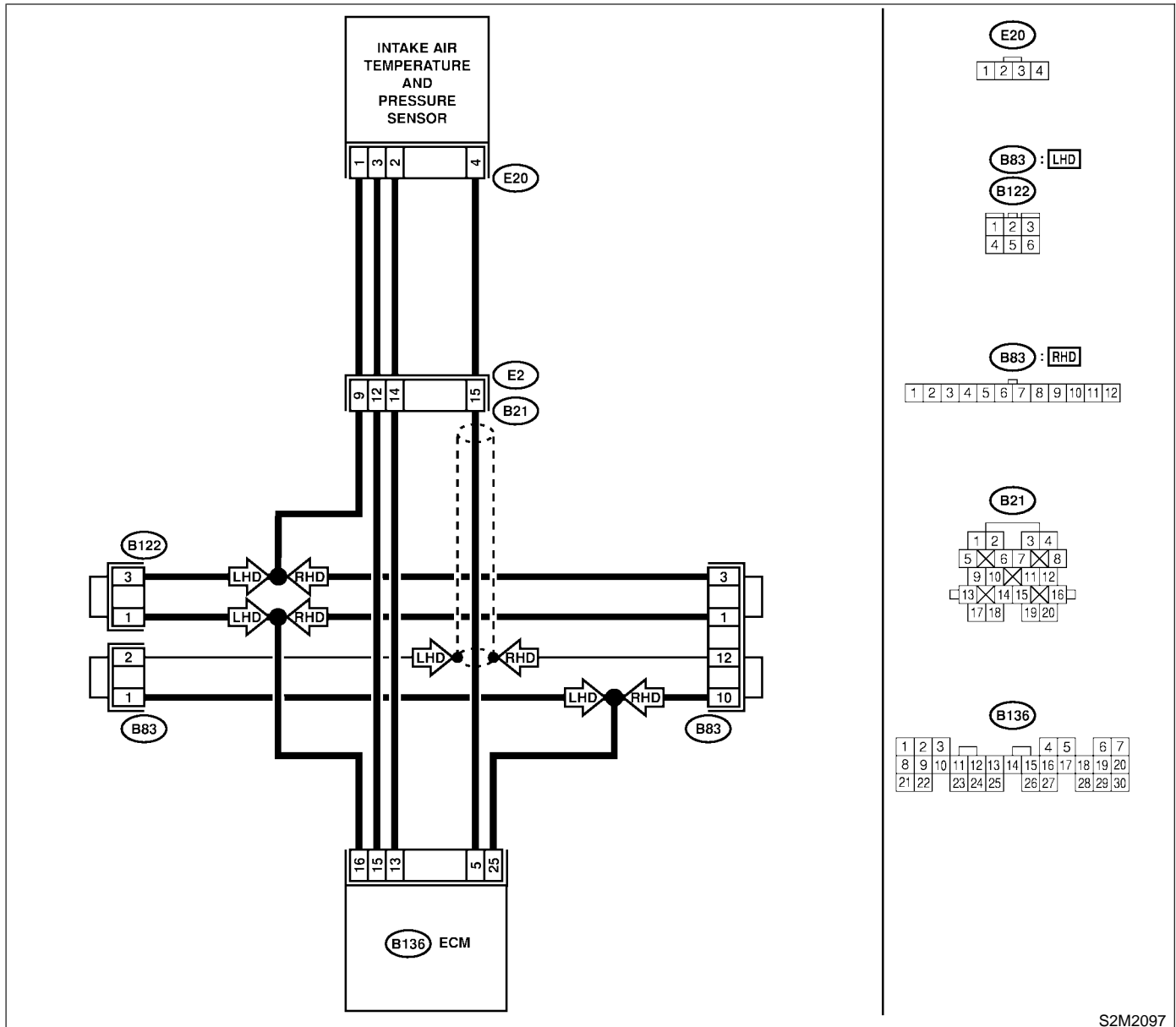

S2M2097

# DIAGNOSTIC PROCEDURE WITH DIAGNOSTIC TROUBLE CODE (DTC)

Engine (Diagnostics)

No.	Step	Check	Yes	No
1	<p><b>CHECK ANY OTHER DTC ON DISPLAY.</b></p>	<p>Does the Subaru Select Monitor or OBD-II general scan tool indicate DTC P0112, P0113, P0117, P0118 or P0125?</p>	<p>Inspect DTC P0112, P0113, P0117, P0118 or P0125 using "17. List of Diagnostic Trouble Code (DTC)". &lt;Ref. to EN(SOHC)-80, List of Diagnostic Trouble Code (DTC).&gt; NOTE: In this case, it is not necessary to inspect DTC P0111.</p>	<p>Go to step 2.</p>
2	<p><b>CHECK ENGINE COOLANT TEMPERATURE.</b> 1) Start the engine and warm it up completely. 2) Measure engine coolant temperature using Subaru Select Monitor or OBD-II general scan tool. NOTE: ● Subaru Select Monitor For detailed operation procedure, refer to the "READ CURRENT DATA FOR ENGINE". &lt;Ref. to EN(SOHC)-34, Subaru Select Monitor.&gt; ● OBD-II general scan tool For detailed operation procedures, refer to the OBD-II General Scan Tool Instruction Manual.</p>	<p>Is the engine coolant temperature between 75°C (167°F) and 95°C (203°F)?</p>	<p>Replace intake air temperature and pressure sensor. &lt;Ref. to FU(SOHC)-36, Intake Air Temperature and Pressure Sensor.&gt;</p>	<p>Inspect DTC P0125 using "17. List of Diagnostic Trouble Code (DTC)". &lt;Ref. to EN(SOHC)-80, List of Diagnostic Trouble Code (DTC).&gt;</p>

# DIAGNOSTIC PROCEDURE WITH DIAGNOSTIC TROUBLE CODE (DTC)

Engine (Diagnostics)

## K: DTC P0112 — INTAKE AIR TEMPERATURE SENSOR CIRCUIT LOW INPUT

S058521B15

- **DTC DETECTING CONDITION:**
  - Immediately at fault recognition
- **TROUBLE SYMPTOM:**
  - Erroneous idling
  - Poor driving performance

### CAUTION:

After repair or replacement of faulty parts, conduct Clear Memory Mode <Ref. to EN(SOHC)-45, OPERATION, Clear Memory Mode.> and Inspection Mode <Ref. to EN(SOHC)-42, OPERATION, Inspection Mode.>.

### ● WIRING DIAGRAM:

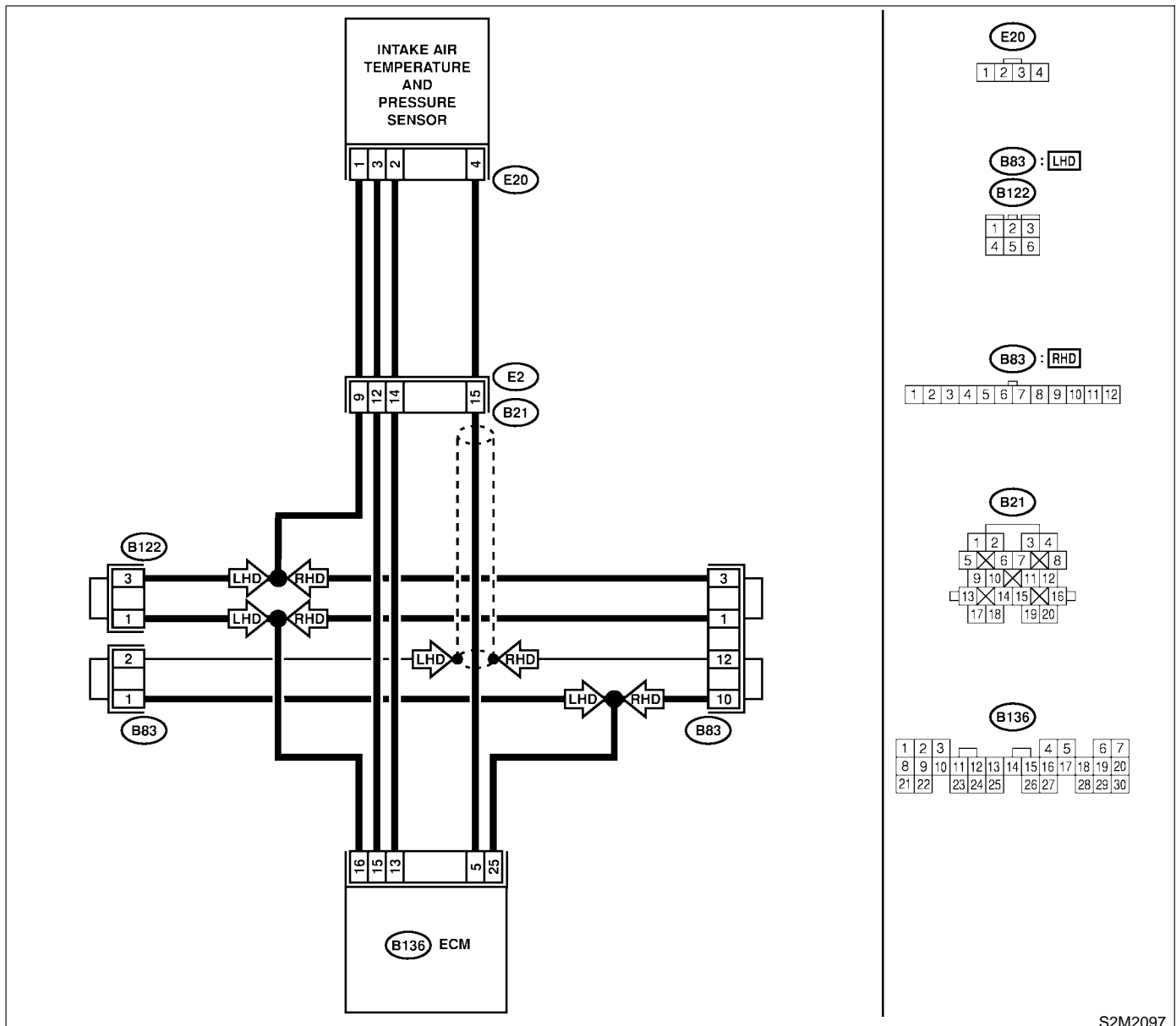

S2M2097

# DIAGNOSTIC PROCEDURE WITH DIAGNOSTIC TROUBLE CODE (DTC)

Engine (Diagnostics)

No.	Step	Check	Yes	No
1	<p><b>CHECK CURRENT DATA.</b></p> <p>1) Start engine. 2) Read data of intake air temperature sensor signal using Subaru Select Monitor or the OBD-II general scan tool.</p> <p>NOTE:</p> <ul style="list-style-type: none"> <li>● Subaru Select Monitor</li> </ul> <p>For detailed operation procedure, refer to the "READ CURRENT DATA FOR ENGINE". &lt;Ref. to EN(SOHC)-34, Subaru Select Monitor.&gt;</p> <ul style="list-style-type: none"> <li>● OBD-II general scan tool</li> </ul> <p>For detailed operation procedure, refer to the OBD-II General Scan Tool Instruction Manual.</p>	<p>Is the value greater than 120°C (248°F)?</p>	<p>Go to step 2.</p>	<p>Repair poor contact.</p> <p>NOTE:</p> <p>In this case, repair the following:</p> <ul style="list-style-type: none"> <li>● Poor contact in intake air temperature and pressure sensor</li> <li>● Poor contact in ECM</li> <li>● Poor contact in coupling connector (B21)</li> <li>● Poor contact in joint connector (B83, B122)</li> </ul>
2	<p><b>CHECK HARNESS BETWEEN INTAKE AIR TEMPERATURE AND PRESSURE SENSOR AND ECM CONNECTOR.</b></p> <p>1) Turn ignition switch to OFF. 2) Disconnect connector from intake air temperature and pressure sensor. 3) Turn ignition switch to ON. 4) Read data of intake air temperature sensor signal using Subaru Select Monitor or the OBD-II general scan tool.</p> <p>NOTE:</p> <ul style="list-style-type: none"> <li>● Subaru Select Monitor</li> </ul> <p>For detailed operation procedure, refer to the "READ CURRENT DATA FOR ENGINE". &lt;Ref. to EN(SOHC)-34, Subaru Select Monitor.&gt;</p> <ul style="list-style-type: none"> <li>● OBD-II general scan tool</li> </ul> <p>For detailed operation procedure, refer to the OBD-II General Scan Tool Instruction Manual.</p>	<p>Is the value less than -40°C (-40°F)?</p>	<p>Replace intake air temperature and pressure sensor. &lt;Ref. to FU(SOHC)-36, Intake Air Temperature and Pressure Sensor.&gt;</p>	<p>Repair ground short circuit in harness between intake air temperature sensor and ECM connector.</p>

# DIAGNOSTIC PROCEDURE WITH DIAGNOSTIC TROUBLE CODE (DTC)

Engine (Diagnostics)

## L: DTC P0113 — INTAKE AIR TEMPERATURE SENSOR CIRCUIT HIGH INPUT

— S058521B16

- **DTC DETECTING CONDITION:**
  - Immediately at fault recognition
- **TROUBLE SYMPTOM:**
  - Erroneous idling
  - Poor driving performance

### CAUTION:

After repair or replacement of faulty parts, conduct Clear Memory Mode <Ref. to EN(SOHC)-45, OPERATION, Clear Memory Mode.> and Inspection Mode <Ref. to EN(SOHC)-42, OPERATION, Inspection Mode.>.

### ● WIRING DIAGRAM:

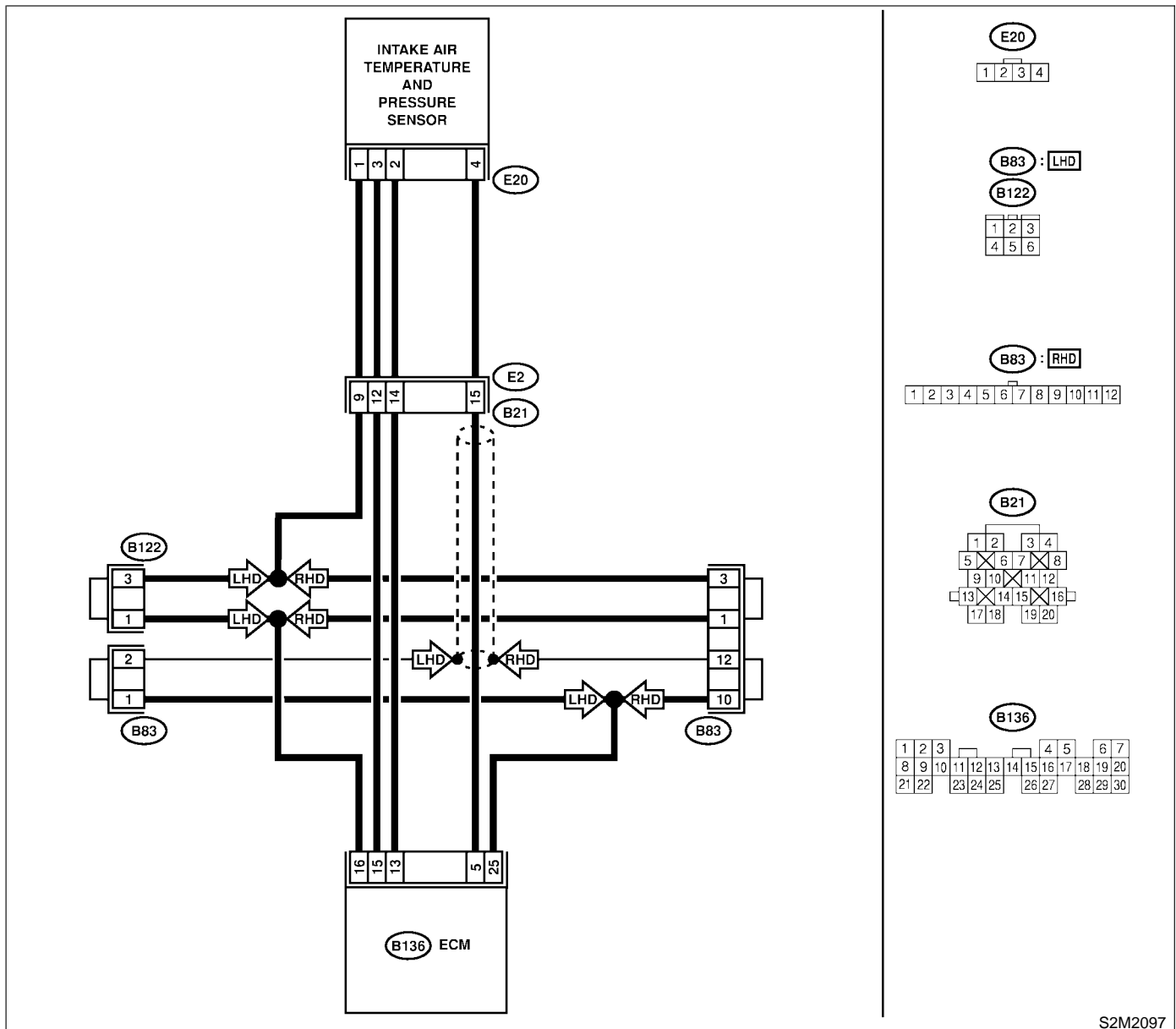

S2M2097

# DIAGNOSTIC PROCEDURE WITH DIAGNOSTIC TROUBLE CODE (DTC)

Engine (Diagnostics)

No.	Step	Check	Yes	No
1	<p><b>CHECK CURRENT DATA.</b></p> <p>1) Start engine.</p> <p>2) Read data of intake air temperature sensor signal using Subaru Select Monitor or the OBD-II general scan tool.</p> <p>NOTE:</p> <ul style="list-style-type: none"> <li>● Subaru Select Monitor</li> </ul> <p>For detailed operation procedure, refer to the "READ CURRENT DATA FOR ENGINE".</p> <p>&lt;Ref. to EN(SOHC)-34, Subaru Select Monitor.&gt;</p> <ul style="list-style-type: none"> <li>● OBD-II general scan tool</li> </ul> <p>For detailed operation procedure, refer to the OBD-II General Scan Tool Instruction Manual.</p>	<p>Is the value less than -40°C (-40°F)?</p>	<p>Go to step 2.</p>	<p>Repair poor contact.</p> <p>NOTE:</p> <p>In this case, repair the following:</p> <ul style="list-style-type: none"> <li>● Poor contact in intake air temperature and pressure sensor</li> <li>● Poor contact in ECM</li> <li>● Poor contact in coupling connector (B21)</li> <li>● Poor contact in joint connector (B83, B122)</li> </ul>
2	<p><b>CHECK HARNESS BETWEEN INTAKE AIR TEMPERATURE AND PRESSURE SENSOR AND ECM CONNECTOR.</b></p> <p>1) Turn ignition switch to OFF.</p> <p>2) Disconnect connector from intake air temperature and pressure sensor.</p> <p>3) Measure voltage between intake air temperature and pressure sensor connector and engine ground.</p> <p><b>Connector &amp; terminal</b> <b>(E20) No. 2 (+) — Engine ground (-):</b></p>	<p>Is the voltage more than 10 V?</p>	<p>Repair battery short circuit in harness between intake air temperature and pressure sensor and ECM connector.</p>	<p>Go to step 3.</p>
3	<p><b>CHECK HARNESS BETWEEN INTAKE AIR TEMPERATURE AND PRESSURE SENSOR AND ECM CONNECTOR.</b></p> <p>1) Turn ignition switch to ON.</p> <p>2) Measure voltage between intake air temperature and pressure sensor connector and engine ground.</p> <p><b>Connector &amp; terminal</b> <b>(E20) No. 2 (+) — Engine ground (-):</b></p>	<p>Is the voltage more than 10 V?</p>	<p>Repair battery short circuit in harness between intake air temperature and pressure sensor and ECM connector.</p>	<p>Go to step 4.</p>

# DIAGNOSTIC PROCEDURE WITH DIAGNOSTIC TROUBLE CODE (DTC)

Engine (Diagnostics)

No.	Step	Check	Yes	No
4	<p><b>CHECK HARNESS BETWEEN INTAKE AIR TEMPERATURE AND PRESSURE SENSOR AND ECM CONNECTOR.</b>                      Measure voltage between intake air temperature and pressure sensor connector and engine ground.  <b>Connector &amp; terminal</b>  <b>(E20) No. 2 (+) — Engine ground (-):</b></p>	<p>Is the voltage more than 3 V?</p>	<p>Go to step 5.</p>	<p>Repair harness and connector.                      NOTE:                      In this case, repair the following:</p> <ul style="list-style-type: none"> <li>● Open circuit in harness between intake air temperature and pressure sensor and ECM connector</li> <li>● Poor contact in intake air temperature and pressure sensor</li> <li>● Poor contact in ECM</li> <li>● Poor contact in coupling connector (B21)</li> <li>● Poor contact in joint connector (B83, B122)</li> </ul>
5	<p><b>CHECK HARNESS BETWEEN INTAKE AIR TEMPERATURE AND PRESSURE SENSOR AND ECM CONNECTOR.</b>                      1) Turn ignition switch to OFF.                      2) Measure resistance of harness between intake air temperature and pressure sensor connector and engine ground.  <b>Connector &amp; terminal</b>  <b>(E20) No. 1 — Engine ground:</b></p>	<p>Is the resistance less than 5 <math>\Omega</math>?</p>	<p>Replace intake air temperature and pressure sensor.                      &lt;Ref. to FU(SOHC)-36, Intake Air Temperature and Pressure Sensor.&gt;</p>	<p>Repair harness and connector.                      NOTE:                      In this case, repair the following:</p> <ul style="list-style-type: none"> <li>● Open circuit in harness between intake air temperature and pressure sensor and ECM connector</li> <li>● Poor contact in intake air temperature and pressure sensor</li> <li>● Poor contact in ECM</li> <li>● Poor contact in coupling connector (B21)</li> <li>● Poor contact in joint connector (B83, B122)</li> </ul>



**MEMO:**

# DIAGNOSTIC PROCEDURE WITH DIAGNOSTIC TROUBLE CODE (DTC)

Engine (Diagnostics)

## M: DTC P0117 — ENGINE COOLANT TEMPERATURE SENSOR CIRCUIT LOW INPUT — S058521F91

- **DTC DETECTING CONDITION:**
  - Immediately at fault recognition
- **TROUBLE SYMPTOM:**
  - Hard to start
  - Erroneous idling
  - Poor driving performance

### CAUTION:

After repair or replacement of faulty parts, conduct Clear Memory Mode <Ref. to EN(SOHC)-45, OPERATION, Clear Memory Mode.> and Inspection Mode <Ref. to EN(SOHC)-42, OPERATION, Inspection Mode.>.

### ● WIRING DIAGRAM:

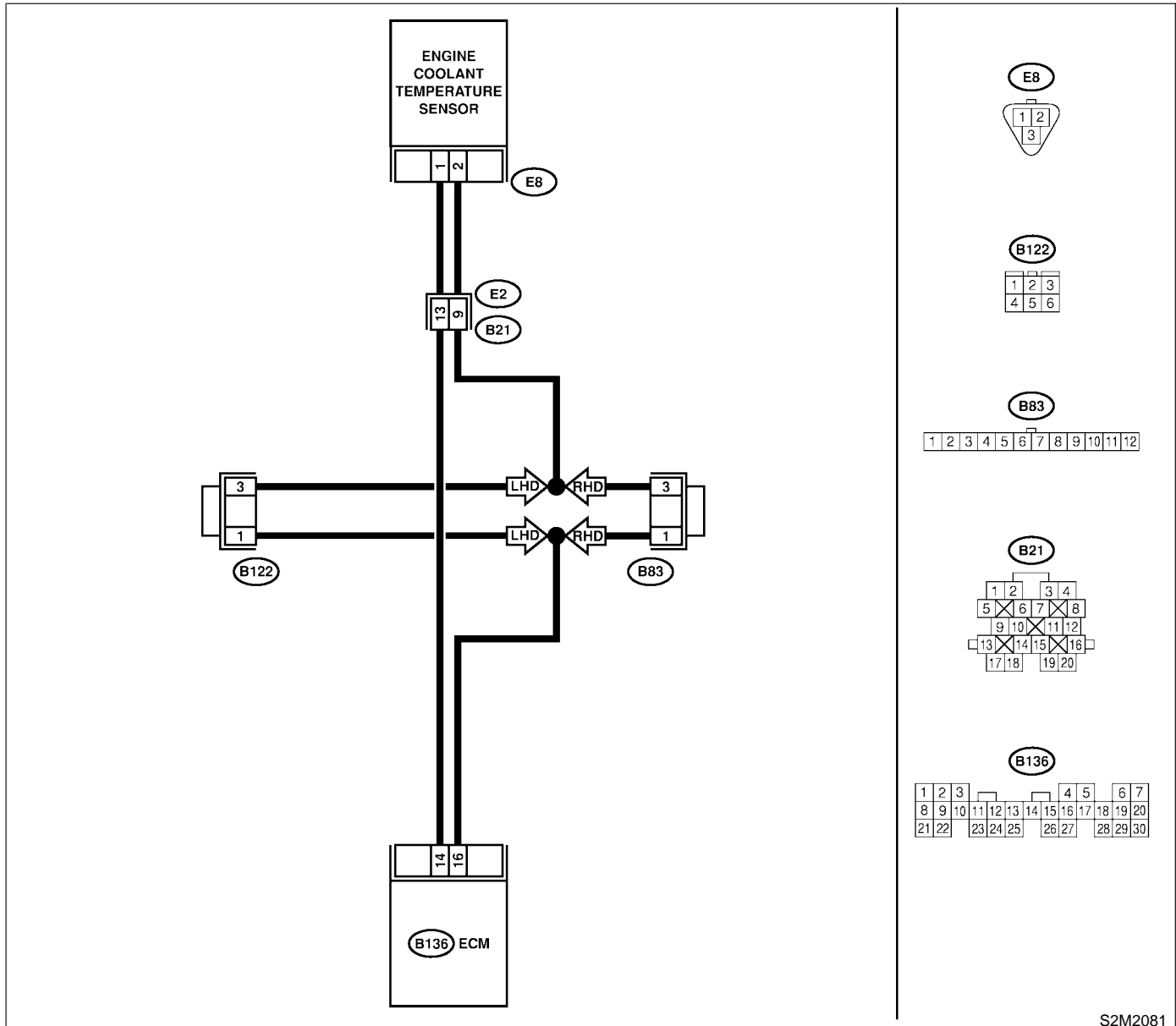

S2M2081

# DIAGNOSTIC PROCEDURE WITH DIAGNOSTIC TROUBLE CODE (DTC)

Engine (Diagnostics)

No.	Step	Check	Yes	No
1	<p><b>CHECK CURRENT DATA.</b></p> <p>1) Start engine.</p> <p>2) Read data of engine coolant temperature sensor signal using Subaru Select Monitor or OBD-II general scan tool.</p> <p>NOTE:</p> <ul style="list-style-type: none"> <li>● Subaru Select Monitor</li> </ul> <p>For detailed operation procedure, refer to the "READ CURRENT DATA FOR ENGINE". &lt;Ref. to EN(SOHC)-34, Subaru Select Monitor.&gt;</p> <ul style="list-style-type: none"> <li>● OBD-II general scan tool</li> </ul> <p>For detailed operation procedures, refer to the OBD-II General Scan Tool Instruction Manual.</p>	Is the value greater than 150°C (302°F)?	Go to step 2.	<p>Repair poor contact.</p> <p>NOTE:</p> <p>In this case, repair the following:</p> <ul style="list-style-type: none"> <li>● Poor contact in engine coolant temperature sensor</li> <li>● Poor contact in ECM</li> <li>● Poor contact in coupling connector (B21)</li> <li>● Poor contact in joint connector</li> </ul> <p>LHD: B122 RHD: B83</p>
2	<p><b>CHECK HARNESS BETWEEN ENGINE COOLANT TEMPERATURE SENSOR AND ECM CONNECTOR.</b></p> <p>1) Turn ignition switch to OFF.</p> <p>2) Disconnect connector from engine coolant temperature sensor.</p> <p>3) Turn ignition switch to ON.</p> <p>4) Read data of engine coolant temperature sensor signal using Subaru Select Monitor or OBD-II general scan tool.</p> <p>NOTE:</p> <ul style="list-style-type: none"> <li>● Subaru Select Monitor</li> </ul> <p>For detailed operation procedure, refer to the "READ CURRENT DATA FOR ENGINE". &lt;Ref. to EN(SOHC)-34, Subaru Select Monitor.&gt;</p> <ul style="list-style-type: none"> <li>● OBD-II general scan tool</li> </ul> <p>For detailed operation procedures, refer to the OBD-II General Scan Tool Instruction Manual.</p>	Is the value less than -40°C (-40°F)?	Replace engine coolant temperature sensor. <Ref. to FU(SOHC)-28, Engine Coolant Temperature Sensor.>	Repair ground short circuit in harness between engine coolant temperature sensor and ECM connector.

# DIAGNOSTIC PROCEDURE WITH DIAGNOSTIC TROUBLE CODE (DTC)

Engine (Diagnostics)

## N: DTC P0118 — ENGINE COOLANT TEMPERATURE SENSOR CIRCUIT HIGH INPUT —

S058521F92

- **DTC DETECTING CONDITION:**
  - Immediately at fault recognition
- **TROUBLE SYMPTOM:**
  - Hard to start
  - Erroneous idling
  - Poor driving performance

### CAUTION:

After repair or replacement of faulty parts, conduct Clear Memory Mode <Ref. to EN(SOHC)-45, OPERATION, Clear Memory Mode.> and Inspection Mode <Ref. to EN(SOHC)-42, OPERATION, Inspection Mode.>.

### ● WIRING DIAGRAM:

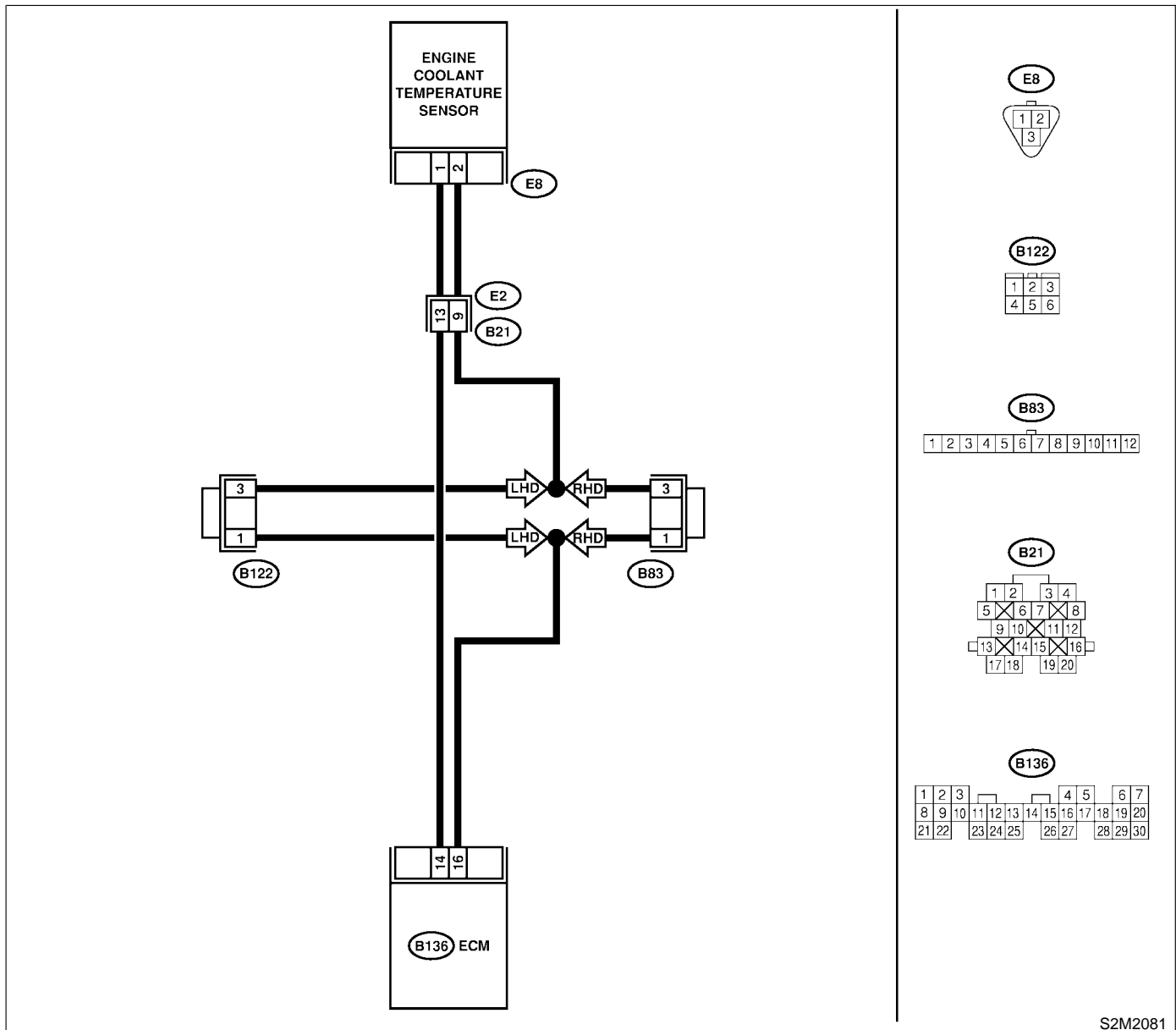

S2M2081

# DIAGNOSTIC PROCEDURE WITH DIAGNOSTIC TROUBLE CODE (DTC)

Engine (Diagnostics)

No.	Step	Check	Yes	No
1	<p><b>CHECK CURRENT DATA.</b></p> <p>1) Start engine.</p> <p>2) Read data of engine coolant temperature sensor signal using Subaru Select Monitor or OBD-II general scan tool.</p> <p>NOTE:</p> <ul style="list-style-type: none"> <li>● Subaru Select Monitor</li> </ul> <p>For detailed operation procedure, refer to the "READ CURRENT DATA FOR ENGINE".</p> <p>&lt;Ref. to EN(SOHC)-34, Subaru Select Monitor.&gt;</p> <ul style="list-style-type: none"> <li>● OBD-II general scan tool</li> </ul> <p>For detailed operation procedures, refer to the OBD-II General Scan Tool Instruction Manual.</p>	Is the value less than -40°C (-40°F)?	Go to step 2.	<p>Repair poor contact.</p> <p>NOTE:</p> <p>In this case, repair the following:</p> <ul style="list-style-type: none"> <li>● Poor contact in engine coolant temperature sensor</li> <li>● Poor contact in ECM</li> <li>● Poor contact in coupling connector (B21)</li> <li>● Poor contact in joint connector</li> </ul> <p>LHD: B122 RHD: B83</p>
2	<p><b>CHECK HARNESS BETWEEN ENGINE COOLANT TEMPERATURE SENSOR AND ECM CONNECTOR.</b></p> <p>1) Turn ignition switch to OFF.</p> <p>2) Disconnect connector from engine coolant temperature sensor.</p> <p>3) Measure voltage between engine coolant temperature sensor connector and engine ground.</p> <p><b>Connector &amp; terminal</b> <b>(E8) No. 1 (+) — Engine ground (-):</b></p>	Is the voltage more than 10 V?	Repair battery short circuit in harness between ECM and engine coolant temperature sensor connector.	Go to step 3.
3	<p><b>CHECK HARNESS BETWEEN ENGINE COOLANT TEMPERATURE SENSOR AND ECM CONNECTOR.</b></p> <p>1) Turn ignition switch to ON.</p> <p>2) Measure voltage between engine coolant temperature sensor connector and engine ground.</p> <p><b>Connector &amp; terminal</b> <b>(E8) No. 1 (+) — Engine ground (-):</b></p>	Is the voltage more than 10 V?	Repair battery short circuit in harness between ECM and engine coolant temperature sensor connector.	Go to step 4.

# DIAGNOSTIC PROCEDURE WITH DIAGNOSTIC TROUBLE CODE (DTC)

Engine (Diagnostics)

No.	Step	Check	Yes	No
4	<p><b>CHECK HARNESS BETWEEN ENGINE COOLANT TEMPERATURE SENSOR AND ECM CONNECTOR.</b></p> <p>Measure voltage between engine coolant temperature sensor connector and engine ground.</p> <p><b>Connector &amp; terminal</b> <b>(E8) No. 1 (+) — Engine ground (-):</b></p>	Is the voltage more than 4 V?	Go to step 5.	<p>Repair harness and connector.</p> <p><b>NOTE:</b> In this case, repair the following:</p> <ul style="list-style-type: none"> <li>● Open circuit in harness between ECM and engine coolant temperature sensor connector</li> <li>● Poor contact in engine coolant temperature sensor connector</li> <li>● Poor contact in ECM connector</li> <li>● Poor contact in coupling connector (B21)</li> <li>● Poor contact in joint connector LHD: B122 RHD: B83</li> </ul>
5	<p><b>CHECK HARNESS BETWEEN ENGINE COOLANT TEMPERATURE SENSOR AND ECM CONNECTOR.</b></p> <p>1) Turn ignition switch to OFF. 2) Measure resistance of harness between engine coolant temperature sensor connector and engine ground.</p> <p><b>Connector &amp; terminal</b> <b>(E8) No. 2 — Engine ground:</b></p>	Is the resistance less than 5 $\Omega$ ?	Replace engine coolant temperature sensor. <Ref. to FU(SOHC)-28, Engine Coolant Temperature Sensor.>	<p>Repair harness and connector.</p> <p><b>NOTE:</b> In this case, repair the following:</p> <ul style="list-style-type: none"> <li>● Open circuit in harness between ECM and engine coolant temperature sensor connector</li> <li>● Poor contact in engine coolant temperature sensor connector</li> <li>● Poor contact in ECM connector</li> <li>● Poor contact in coupling connector (B21)</li> <li>● Poor contact in joint connector LHD: B122 RHD: B83</li> </ul>

**MEMO:**

# DIAGNOSTIC PROCEDURE WITH DIAGNOSTIC TROUBLE CODE (DTC)

Engine (Diagnostics)

## O: DTC P0121 — THROTTLE POSITION SENSOR CIRCUIT RANGE/PERFORMANCE PROBLEM (HIGH INPUT) — S058521B19

- **DTC DETECTING CONDITION:**
  - Two consecutive driving cycles with fault
- **TROUBLE SYMPTOM:**
  - Erroneous idling
  - Engine stalls.
  - Poor driving performance

### CAUTION:

After repair or replacement of faulty parts, conduct Clear Memory Mode <Ref. to EN(SOHC)-45 OPERATION, Clear Memory Mode.> and Inspection Mode <Ref. to EN(SOHC)-42 OPERATION, Inspection Mode.>.

### ● WIRING DIAGRAM:

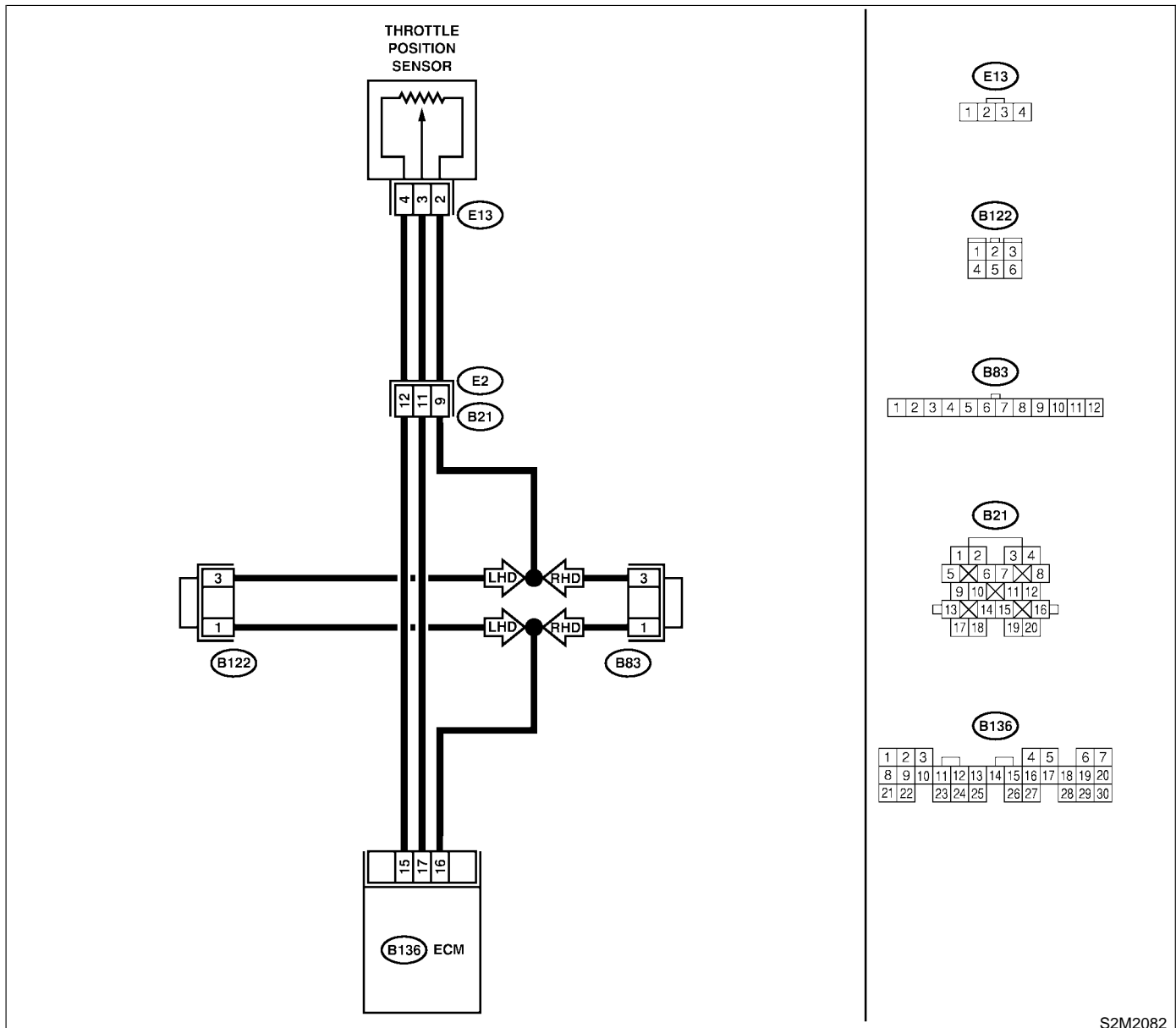

S2M2082



# DIAGNOSTIC PROCEDURE WITH DIAGNOSTIC TROUBLE CODE (DTC)

Engine (Diagnostics)

No.	Step	Check	Yes	No
1	CHECK ANY OTHER DTC ON DISPLAY.	Does the Subaru Select Monitor or OBD-II general scan tool indicate DTC P0122 or P0123?	Inspect DTC P0122 or P0123 using "17. List of Diagnostic Trouble Code (DTC)". <Ref. to EN(SOHC)-80, List of Diagnostic Trouble Code (DTC).> NOTE: In this case, it is not necessary to inspect DTC P0121.	Replace throttle position sensor. <Ref. to FU(SOHC)-33, Throttle Position Sensor.>

# DIAGNOSTIC PROCEDURE WITH DIAGNOSTIC TROUBLE CODE (DTC)

Engine (Diagnostics)

## P: DTC P0122 — THROTTLE POSITION SENSOR CIRCUIT LOW INPUT —

S058521B20

- **DTC DETECTING CONDITION:**
  - Immediately at fault recognition
- **TROUBLE SYMPTOM:**
  - Erroneous idling
  - Engine stalls.
  - Poor driving performance

### CAUTION:

After repair or replacement of faulty parts, conduct Clear Memory Mode <Ref. to EN(SOHC)-45, OPERATION, Clear Memory Mode.> and Inspection Mode <Ref. to EN(SOHC)-42, OPERATION, Inspection Mode.>.

### ● WIRING DIAGRAM:

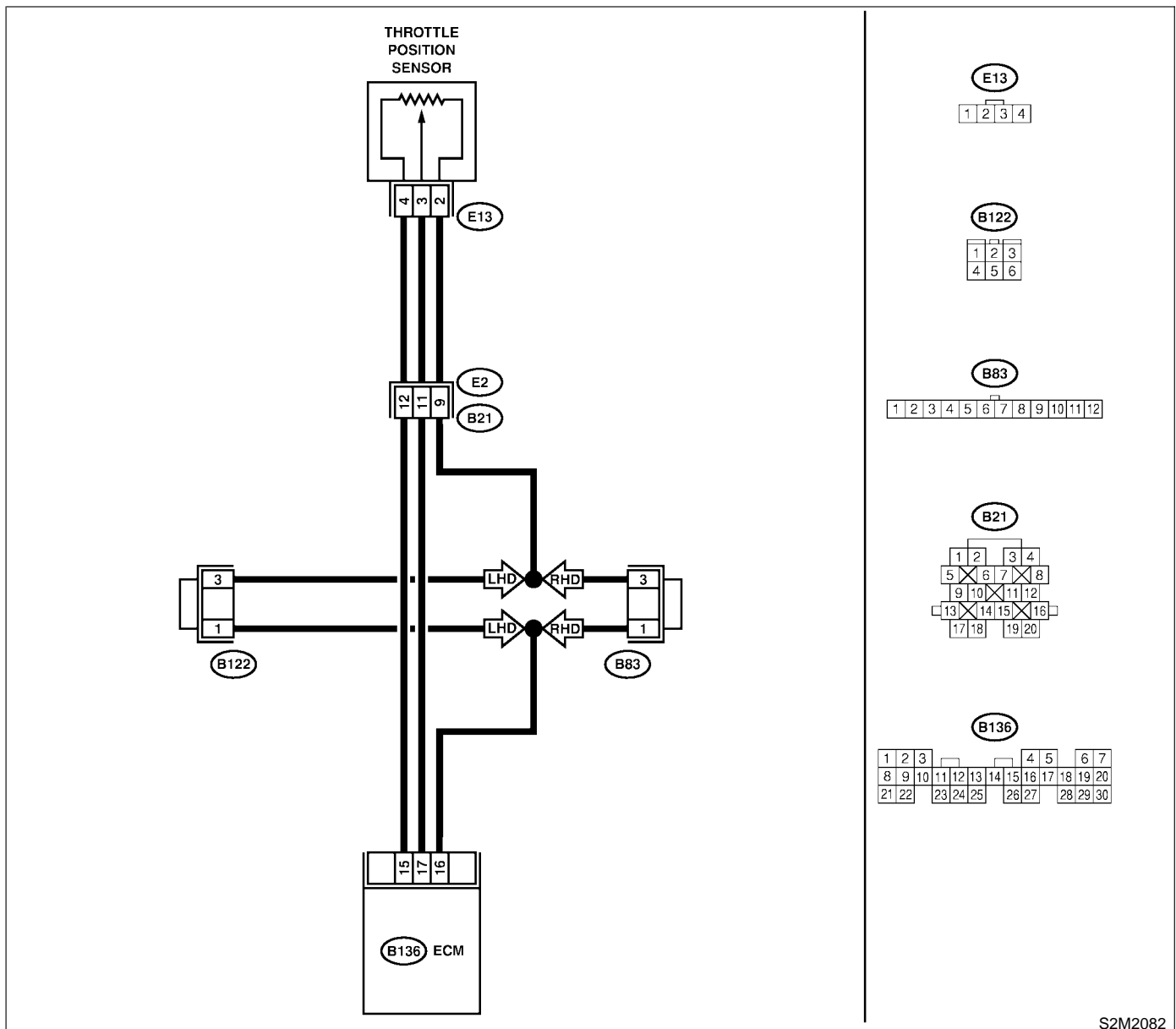

S2M2082

# DIAGNOSTIC PROCEDURE WITH DIAGNOSTIC TROUBLE CODE (DTC)

Engine (Diagnostics)

No.	Step	Check	Yes	No
1	<p><b>CHECK CURRENT DATA.</b>                      1) Start engine.                      2) Read data of throttle position sensor signal using Subaru Select Monitor or OBD-II general scan tool.                      NOTE:                      ● Subaru Select Monitor                      For detailed operation procedure, refer to the "READ CURRENT DATA FOR ENGINE".                      &lt;Ref. to EN(SOHC)-34, Subaru Select Monitor.&gt;                      ● OBD-II general scan tool                      For detailed operation procedures, refer to the OBD-II General Scan Tool Instruction Manual.</p>	Is the value less than 0.1 V?	Go to step 2.	Even if MIL lights up, the circuit has returned to a normal condition at this time. A temporary poor contact of the connector may be the cause. NOTE: In this case, repair the following: ● Poor contact in throttle position sensor connector ● Poor contact in ECM connector ● Poor contact in coupling connector (B21)
2	<p><b>CHECK INPUT SIGNAL FOR ECM.</b>                      Measure voltage between ECM connector and chassis ground while throttle valve is fully closed.  <b>Connector &amp; terminal</b>  <b>(B136) No. 15 (+) — Chassis ground (-):</b></p>	Is the voltage more than 4.5 V?	Go to step 4.	Go to step 3.
3	<p><b>CHECK INPUT SIGNAL FOR ECM.</b>                      Measure voltage between ECM connector and chassis ground.  <b>Connector &amp; terminal</b>  <b>(B136) No. 15 (+) — Chassis ground (-):</b></p>	Does the voltage change more than 4.5 V by shaking harness and connector of ECM while monitoring the value with voltage meter?	Repair poor contact in ECM connector.	Contact your Subaru distributor. NOTE: Inspection by DTM is required, because probable cause is deterioration of multiple parts.
4	<p><b>CHECK INPUT SIGNAL FOR ECM.</b>                      Measure voltage between ECM connector and chassis ground.  <b>Connector &amp; terminal</b>  <b>(B136) No. 17 (+) — Chassis ground (-):</b></p>	Is the voltage less than 0.1 V?	Go to step 6.	Go to step 5.
5	<p><b>CHECK INPUT SIGNAL FOR ECM. (USING SUBARU SELECT MONITOR.)</b>                      Measure voltage between ECM connector and chassis ground.</p>	Does the voltage change more than 0.1 V by shaking harness and connector of ECM while monitoring the value with Subaru Select Monitor?	Repair poor contact in ECM connector.	Go to step 6.

# DIAGNOSTIC PROCEDURE WITH DIAGNOSTIC TROUBLE CODE (DTC)

Engine (Diagnostics)

No.	Step	Check	Yes	No
6	<p><b>CHECK HARNESS BETWEEN ECM AND THROTTLE POSITION SENSOR CONNECTOR.</b></p> <p>1) Turn ignition switch to OFF. 2) Disconnect connectors from throttle position sensor. 3) Turn ignition switch to ON. 4) Measure voltage between throttle position sensor connector and engine ground.</p> <p><b>Connector &amp; terminal</b> <b>(E13) No. 4 (+) — Engine ground (-):</b></p>	Is the voltage more than 4.5 V?	Go to step 7.	<p>Repair harness and connector.</p> <p>NOTE: In this case, repair the following:</p> <ul style="list-style-type: none"> <li>● Open circuit in harness between throttle position sensor and ECM connector</li> <li>● Poor contact in throttle position sensor connector</li> <li>● Poor contact in ECM connector</li> <li>● Poor contact in coupling connector (B21)</li> <li>● Poor contact in joint connector LHD: B122 RHD: B83</li> </ul>
7	<p><b>CHECK HARNESS BETWEEN ECM AND THROTTLE POSITION SENSOR CONNECTOR.</b></p> <p>1) Turn ignition switch to OFF. 2) Measure resistance of harness between ECM connector and throttle position sensor connector.</p> <p><b>Connector &amp; terminal</b> <b>(B136) No. 17 — (E13) No. 3:</b></p>	Is the resistance less than 1 $\Omega$ ?	Go to step 8.	<p>Repair harness and connector.</p> <p>NOTE: In this case, repair the following:</p> <ul style="list-style-type: none"> <li>● Open circuit in harness between throttle position sensor and ECM connector</li> <li>● Poor contact in ECM connector</li> <li>● Poor contact in throttle position sensor connector</li> <li>● Poor contact in coupling connector (B21)</li> </ul>
8	<p><b>CHECK HARNESS BETWEEN ECM AND THROTTLE POSITION SENSOR CONNECTOR.</b></p> <p>Measure resistance of harness between throttle position sensor connector and engine ground.</p> <p><b>Connector &amp; terminal</b> <b>(E13) No. 3 — Engine ground:</b></p>	Is the resistance less than 10 $\Omega$ ?	Repair ground short circuit in harness between throttle position sensor and ECM connector.	Go to step 9.
9	<p><b>CHECK POOR CONTACT.</b></p> <p>Check poor contact in throttle position sensor connector.</p>	Is there poor contact in throttle position sensor connector?	Repair poor contact in throttle position sensor connector.	Replace throttle position sensor. <Ref. to FU(SOHC)-33, Throttle Position Sensor.>

**MEMO:**

# DIAGNOSTIC PROCEDURE WITH DIAGNOSTIC TROUBLE CODE (DTC)

Engine (Diagnostics)

## Q: DTC P0123 — THROTTLE POSITION SENSOR CIRCUIT HIGH INPUT —

S058521B21

- **DTC DETECTING CONDITION:**
  - Immediately at fault recognition
- **TROUBLE SYMPTOM:**
  - Erroneous idling
  - Engine stalls.
  - Poor driving performance

### CAUTION:

After repair or replacement of faulty parts, conduct Clear Memory Mode <Ref. to EN(SOHC)-45, OPERATION, Clear Memory Mode.> and Inspection Mode <Ref. to EN(SOHC)-42, OPERATION, Inspection Mode.>.

### ● WIRING DIAGRAM:

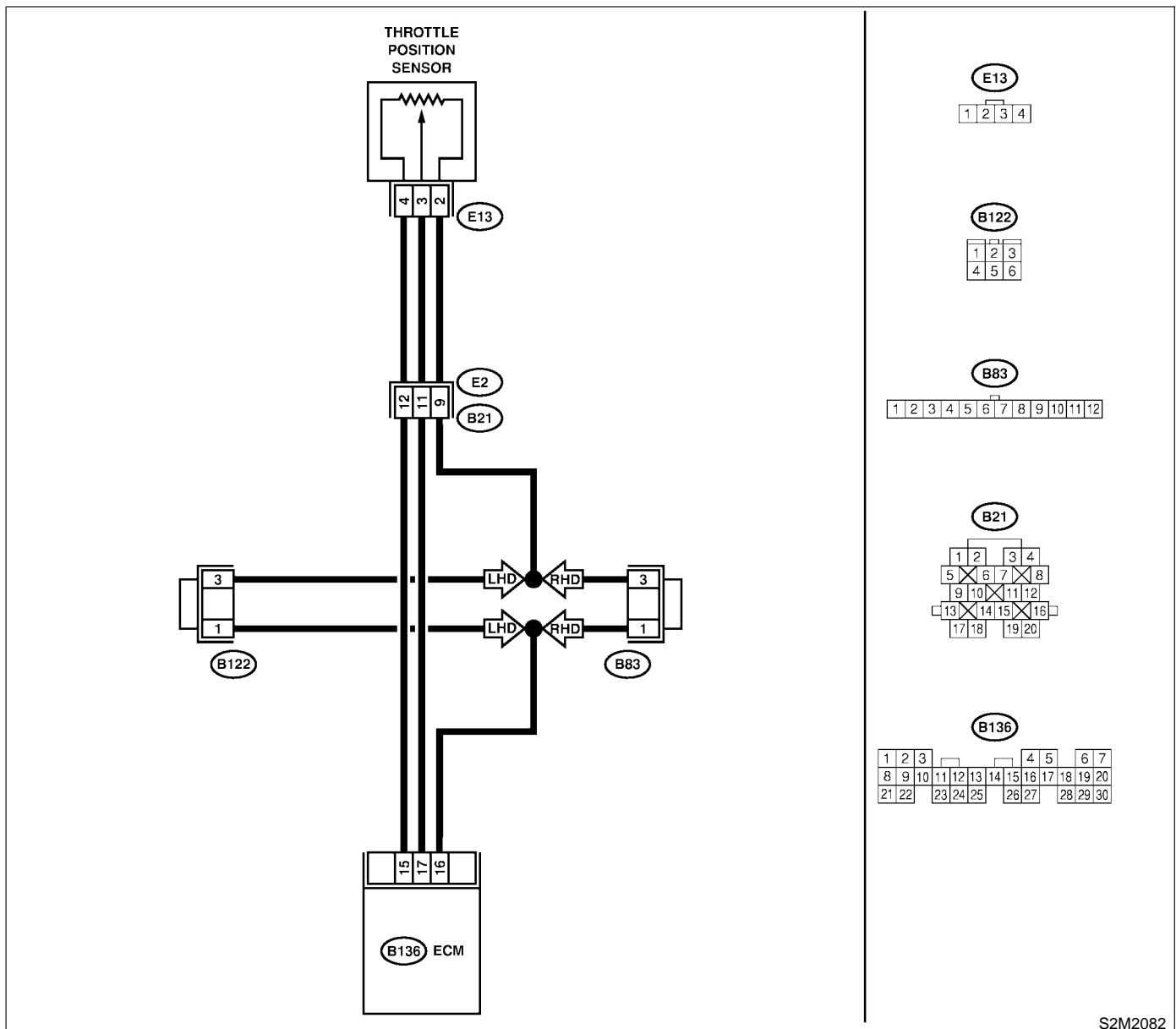

S2M2082

# DIAGNOSTIC PROCEDURE WITH DIAGNOSTIC TROUBLE CODE (DTC)

Engine (Diagnostics)

No.	Step	Check	Yes	No
1	<p><b>CHECK CURRENT DATA.</b></p> <p>1) Start engine.</p> <p>2) Read data of throttle position sensor signal using Subaru Select Monitor or OBD-II general scan tool.</p> <p>NOTE:</p> <ul style="list-style-type: none"> <li>● Subaru Select Monitor</li> </ul> <p>For detailed operation procedure, refer to the "READ CURRENT DATA FOR ENGINE".</p> <p>&lt;Ref. to EN(SOHC)-34, Subaru Select Monitor.&gt;</p> <ul style="list-style-type: none"> <li>● OBD-II general scan tool</li> </ul> <p>For detailed operation procedures, refer to the OBD-II General Scan Tool Instruction Manual.</p>	Is the value more than 4.9 V?	Go to step 2.	<p>Even if MIL lights up, the circuit has returned to a normal condition at this time. A temporary poor contact of the connector may be the cause.</p> <p>NOTE:</p> <p>In this case, repair the following:</p> <ul style="list-style-type: none"> <li>● Poor contact in throttle position sensor connector</li> <li>● Poor contact in ECM connector</li> <li>● Poor contact in coupling connector (B21)</li> </ul>
2	<p><b>CHECK HARNESS BETWEEN THROTTLE POSITION SENSOR AND ECM CONNECTOR.</b></p> <p>1) Turn ignition switch to OFF.</p> <p>2) Disconnect connector from throttle position sensor.</p> <p>3) Measure resistance of harness between throttle position sensor connector and engine ground.</p> <p><b>Connector &amp; terminal</b></p> <p><b>(E13) No. 2 — Engine ground:</b></p>	Is the resistance less than 5 Ω?	Go to step 3.	<p>Repair harness and connector.</p> <p>NOTE:</p> <p>In this case, repair the following:</p> <ul style="list-style-type: none"> <li>● Open circuit in harness between throttle position sensor and ECM connector</li> <li>● Poor contact in coupling connector (B21)</li> <li>● Poor contact in joint connector</li> </ul> <p>LHD: B122 RHD: B83</p>
3	<p><b>CHECK HARNESS BETWEEN THROTTLE POSITION SENSOR AND ECM CONNECTOR.</b></p> <p>1) Turn ignition switch to ON.</p> <p>2) Measure voltage between throttle position sensor connector and engine ground.</p> <p><b>Connector &amp; terminal</b></p> <p><b>(E13) No. 3 (+) — Engine ground (-):</b></p>	Is the voltage more than 4.9 V?	Repair battery short circuit in harness between throttle position sensor and ECM connector. After repair, replace ECM. <Ref. to FU(SOHC)-49, Engine Control Module.>	<p>Replace throttle position sensor.</p> <p>&lt;Ref. to FU(SOHC)-33 Throttle Position Sensor.&gt;</p>

# DIAGNOSTIC PROCEDURE WITH DIAGNOSTIC TROUBLE CODE (DTC)

Engine (Diagnostics)

## R: DTC P0125 — INSUFFICIENT COOLANT TEMPERATURE FOR CLOSED LOOP FUEL CONTROL —

S058521B22

### ● DTC DETECTING CONDITION:

- Two consecutive driving cycles with fault

### ● TROUBLE SYMPTOM:

- Engine would not return to idling.

### CAUTION:

After repair or replacement of faulty parts, conduct Clear Memory Mode <Ref. to EN(SOHC)-45, OPERATION, Clear Memory Mode.> and Inspection Mode <Ref. to EN(SOHC)-42, OPERATION, Inspection Mode.>.

### ● WIRING DIAGRAM:

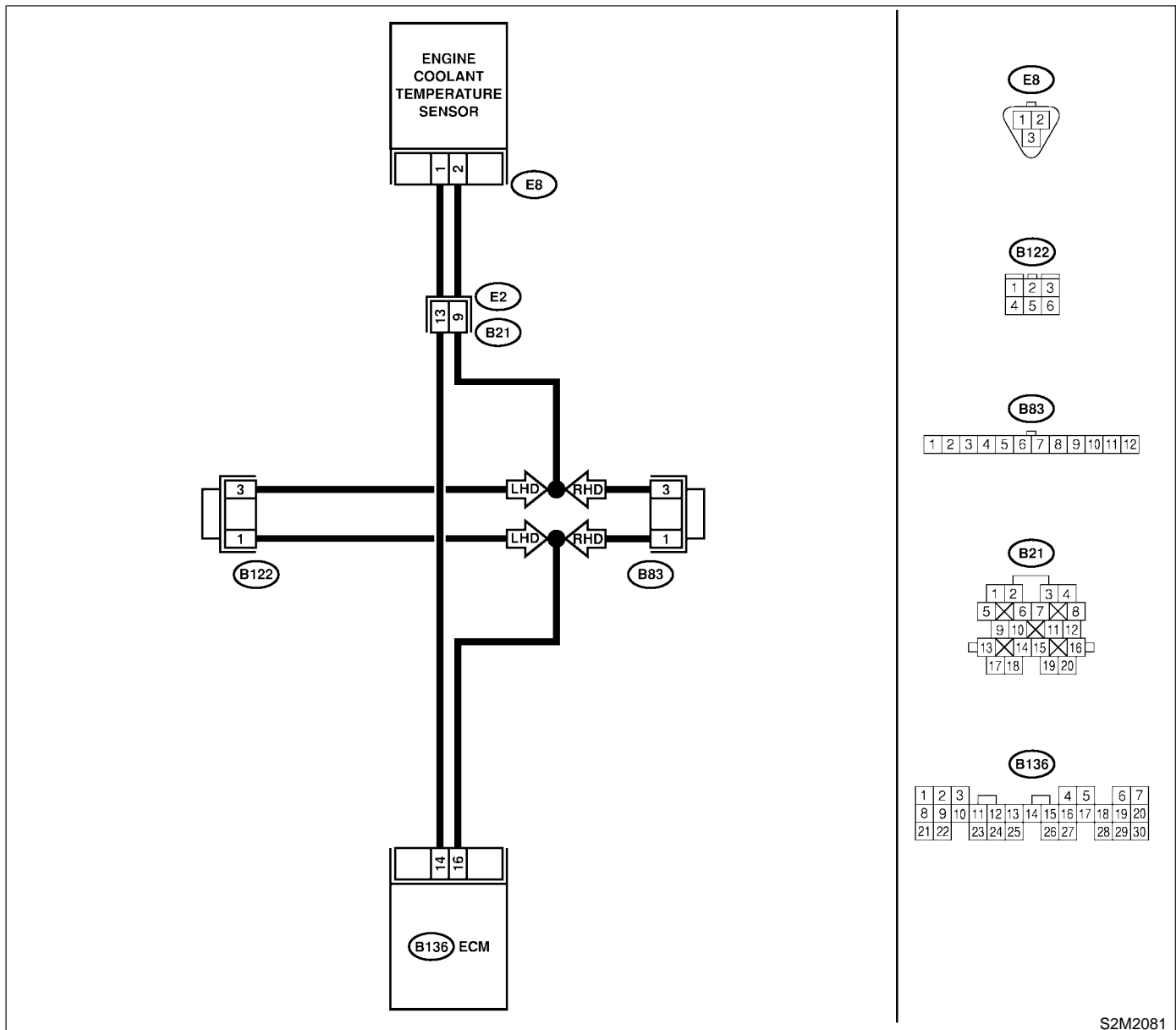

S2M2081



# DIAGNOSTIC PROCEDURE WITH DIAGNOSTIC TROUBLE CODE (DTC)

Engine (Diagnostics)

No.	Step	Check	Yes	No
1	CHECK ANY OTHER DTC ON DISPLAY.	Does the Subaru Select Monitor or OBD-II general scan tool indicate DTC P0117 or P0118?	Inspect DTC P0117 or P0118 using "17. List of Diagnostic Trouble Code (DTC)". <Ref. to EN(SOHC)-80, List of Diagnostic Trouble Code (DTC).> NOTE: In this case, it is not necessary to inspect DTC P0125.	Go to step 2.
2	CHECK THERMOSTAT.	Does thermostat remain opened?	Replace thermostat. <Ref. to CO-23, Thermostat.>	Replace engine coolant temperature sensor. <Ref. to FU(SOHC)-28, Engine Coolant Temperature Sensor.>

# DIAGNOSTIC PROCEDURE WITH DIAGNOSTIC TROUBLE CODE (DTC)

Engine (Diagnostics)

## S: DTC P0130 — FRONT OXYGEN (A/F) SENSOR CIRCUIT RANGE/PERFORMANCE PROBLEM (LEAN) — S058521G44

- DTC DETECTING CONDITION:
  - Immediately at fault recognition

### CAUTION:

After repair or replacement of faulty parts, conduct Clear Memory Mode <Ref. to EN(SOHC)-45, OPERATION, Clear Memory Mode.> and Inspection Mode <Ref. to EN(SOHC)-42, OPERATION, Inspection Mode.>.

### ● WIRING DIAGRAM:

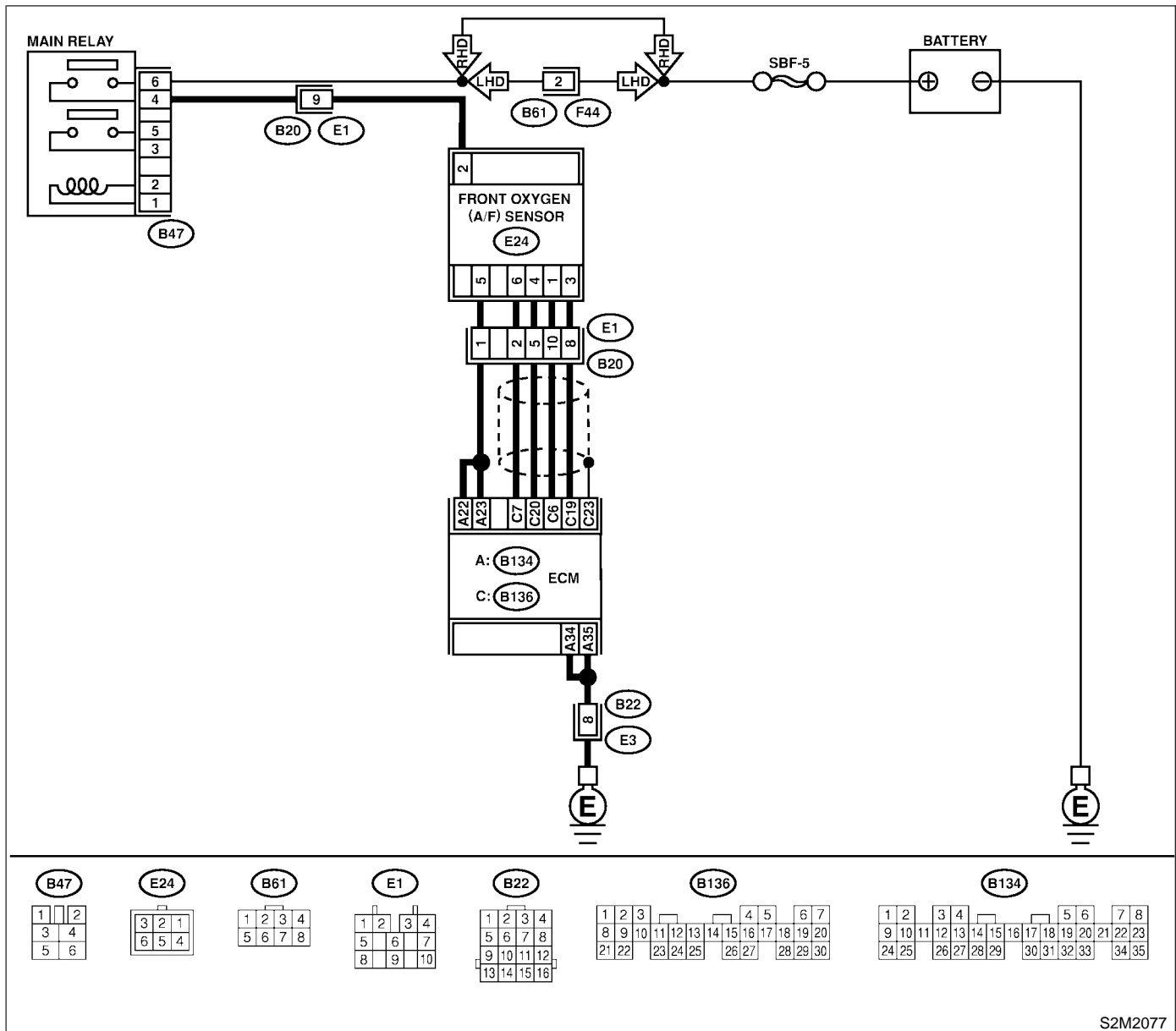

S2M2077

# DIAGNOSTIC PROCEDURE WITH DIAGNOSTIC TROUBLE CODE (DTC)

Engine (Diagnostics)

No.	Step	Check	Yes	No
1	<b>CHECK ANY OTHER DTC ON DISPLAY.</b>	Does the Subaru Select Monitor or OBD-II general scan tool indicate DTC P0131, P0132, P0031 or P0032?	Inspect DTC P0131, P0132, P0031 or P0032 using "17. List of Diagnostic Trouble Code (DTC)". <Ref. to EN(SOHC)-80, List of Diagnostic Trouble Code (DTC).>	Go to step 2.
2	<b>CHECK FRONT OXYGEN (A/F) SENSOR DATA.</b> 1) Start engine. 2) While observing the Subaru Select Monitor or OBD-II general scan tool screen, warm-up the engine until coolant temperature is above 70°C (160°F). If the engine is already warmed-up, operate at idle speed for at least 1 minute. 3) Read data of front oxygen (A/F) sensor signal using Subaru Select Monitor or OBD-II general scan tool. <b>NOTE:</b> ● Subaru Select Monitor For detailed operation procedure, refer to the "READ CURRENT DATA FOR ENGINE". <Ref. to EN(SOHC)-34, Subaru Select Monitor.> ● OBD-II general scan tool For detailed operation procedures, refer to the OBD-II General Scan Tool Instruction Manual.	Is the value equal to or more than 0.85 and equal to less than 1.15 in idling?	Go to step 3.	Go to step 4.
3	<b>CHECK FRONT OXYGEN (A/F) SENSOR DATA.</b> Race engine at speeds from idling to 5,000 rpm for a total of 5 cycles. <b>NOTE:</b> To increase engine speed to 5,000 rpm, slowly depress accelerator pedal, taking approximately 5 seconds, and quickly release accelerator pedal to decrease engine speed.	Is the value more than 1.1 for a moment?	Go to step 6.	Go to step 4.
4	<b>CHECK HARNESS BETWEEN ECM AND FRONT OXYGEN (A/F) SENSOR.</b> 1) Turn ignition switch to OFF. 2) Disconnect connector from ECM and front oxygen (A/F) sensor connector. 3) Measure resistance between ECM and front oxygen (A/F) sensor. <b>Connector &amp; terminals</b> (B136) No. 6 — (E24) No. 1: (B136) No. 7 — (E24) No. 6: (B136) No. 19 — (E24) No. 3: (B136) No. 20 — (E24) No. 4:	Is the resistance less than 5 Ω?	Go to step 5.	Repair open circuit between ECM and front oxygen (A/F) sensor.

# DIAGNOSTIC PROCEDURE WITH DIAGNOSTIC TROUBLE CODE (DTC)

Engine (Diagnostics)

No.	Step	Check	Yes	No
5	<p><b>CHECK HARNESS BETWEEN ECM AND FRONT OXYGEN (A/F) SENSOR.</b>                      Measure resistance between ECM and chassis ground.</p> <p><b>Connector &amp; terminals</b>                      (B136) No. 6 — Chassis ground:                      (B136) No. 7 — Chassis ground:                      (B136) No. 19 — Chassis ground:                      (B136) No. 20 — Chassis ground:</p>	Is the resistance more than 1 MΩ?	Go to step 6.	Repair ground short circuit between ECM and front oxygen (A/F) sensor.
6	<p><b>CHECK EXHAUST SYSTEM.</b>                      Check exhaust system parts.                      NOTE:                      Check the following items.</p> <ul style="list-style-type: none"> <li>● Loose installation of portions</li> <li>● Damage (crack, hole etc.) of parts</li> <li>● Looseness of front oxygen (A/F) sensor</li> <li>● Looseness and ill fitting of parts between front oxygen (A/F) sensor and rear oxygen sensor</li> </ul>	Is there a fault in exhaust system?	Repair or replace faulty parts.	Replace front oxygen (A/F) sensor. <Ref. to FU(SOHC)-45, Front Oxygen (A/F) Sensor.>

**MEMO:**

# DIAGNOSTIC PROCEDURE WITH DIAGNOSTIC TROUBLE CODE (DTC)

Engine (Diagnostics)

## T: DTC P0131 — FRONT OXYGEN (A/F) SENSOR CIRCUIT MALFUNCTION (OPEN CIRCUIT) — S058521G45

- DTC DETECTING CONDITION:
  - Immediately at fault recognition

### CAUTION:

After repair or replacement of faulty parts, conduct Clear Memory Mode <Ref. to EN(SOHC)-45, OPERATION, Clear Memory Mode.> and Inspection Mode <Ref. to EN(SOHC)-42, OPERATION, Inspection Mode.>.

### ● WIRING DIAGRAM:

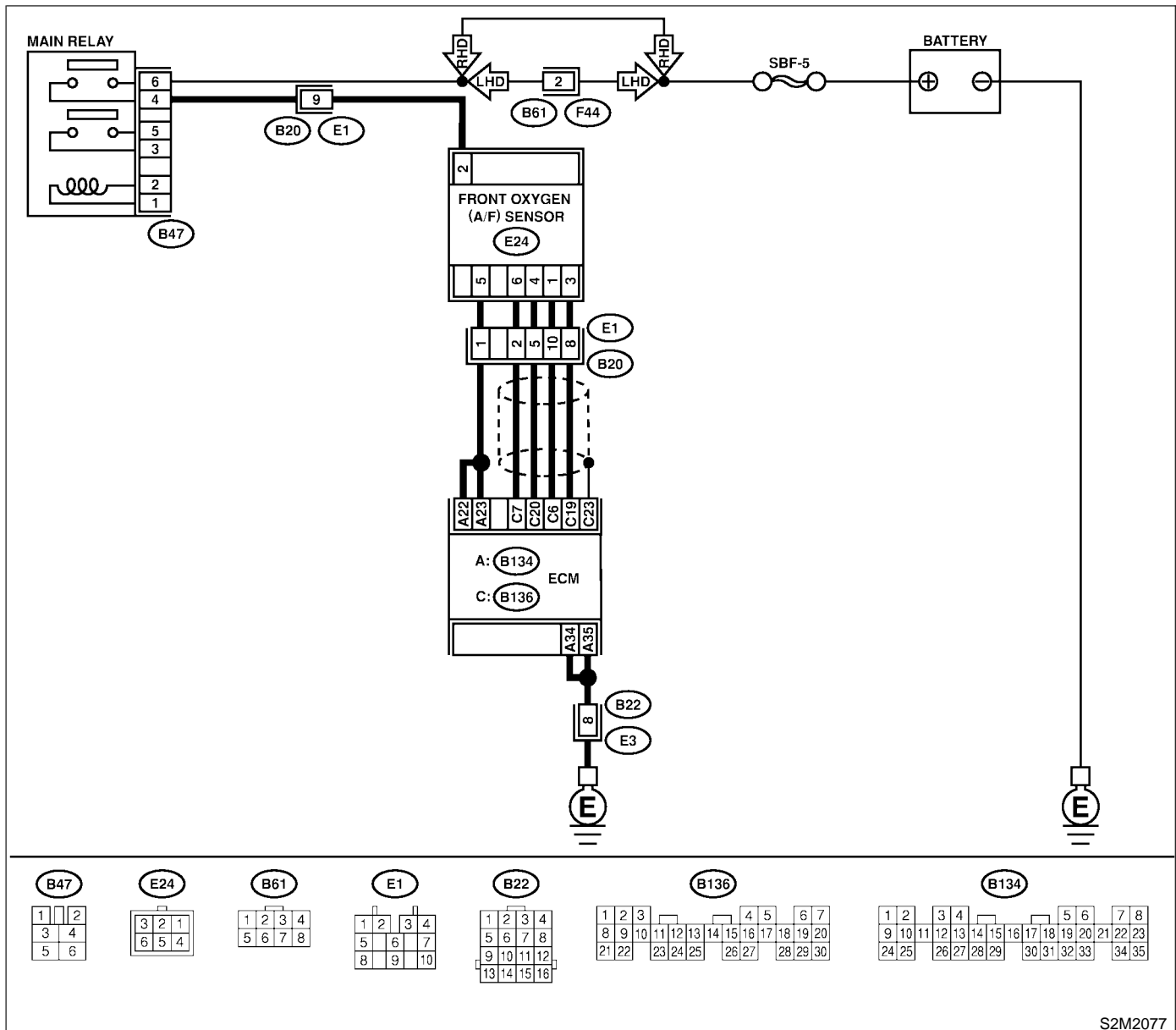

S2M2077

# DIAGNOSTIC PROCEDURE WITH DIAGNOSTIC TROUBLE CODE (DTC)

Engine (Diagnostics)

No.	Step	Check	Yes	No
1	<p><b>CHECK HARNESS BETWEEN ECM AND FRONT OXYGEN (A/F) SENSOR CONNECTOR.</b></p> <p>1) Turn ignition switch to OFF.                      2) Disconnect connectors from ECM and front oxygen (A/F) sensor connector.                      3) Measure resistance of harness between ECM and front oxygen (A/F) sensor connector.</p> <p><b>Connector &amp; terminal</b>                      (B136) No. 6 — (E24) No. 1:                      (B136) No. 7 — (E24) No. 6:                      (B136) No. 19 — (E24) No. 3:                      (B136) No. 20 — (E24) No. 4:</p>	Is the resistance less than 1 Ω?	Go to step 2.	Repair harness and connector. NOTE: In this case, repair the following: <ul style="list-style-type: none"> <li>● Open circuit in harness between ECM and front oxygen (A/F) sensor connector</li> <li>● Poor contact in front oxygen (A/F) sensor connector</li> <li>● Poor contact in ECM connector</li> </ul>
2	<p><b>CHECK POOR CONTACT.</b></p> <p>Check poor contact in front oxygen (A/F) sensor connector.</p>	Is there poor contact in front oxygen (A/F) sensor connector?	Repair poor contact in front oxygen (A/F) sensor connector.	Replace front oxygen (A/F) sensor. <Ref. to FU(SOHC)-45, Front Oxygen (A/F) Sensor.>

# DIAGNOSTIC PROCEDURE WITH DIAGNOSTIC TROUBLE CODE (DTC)

Engine (Diagnostics)

## U: DTC P0132 — FRONT OXYGEN (A/F) SENSOR CIRCUIT MALFUNCTION (SHORT CIRCUIT) — S058521G46

- DTC DETECTING CONDITION:
  - Immediately at fault recognition

### CAUTION:

After repair or replacement of faulty parts, conduct Clear Memory Mode <Ref. to EN(SOHC)-45, OPERATION, Clear Memory Mode.> and Inspection Mode <Ref. to EN(SOHC)-42, OPERATION, Inspection Mode.>.

### ● WIRING DIAGRAM:

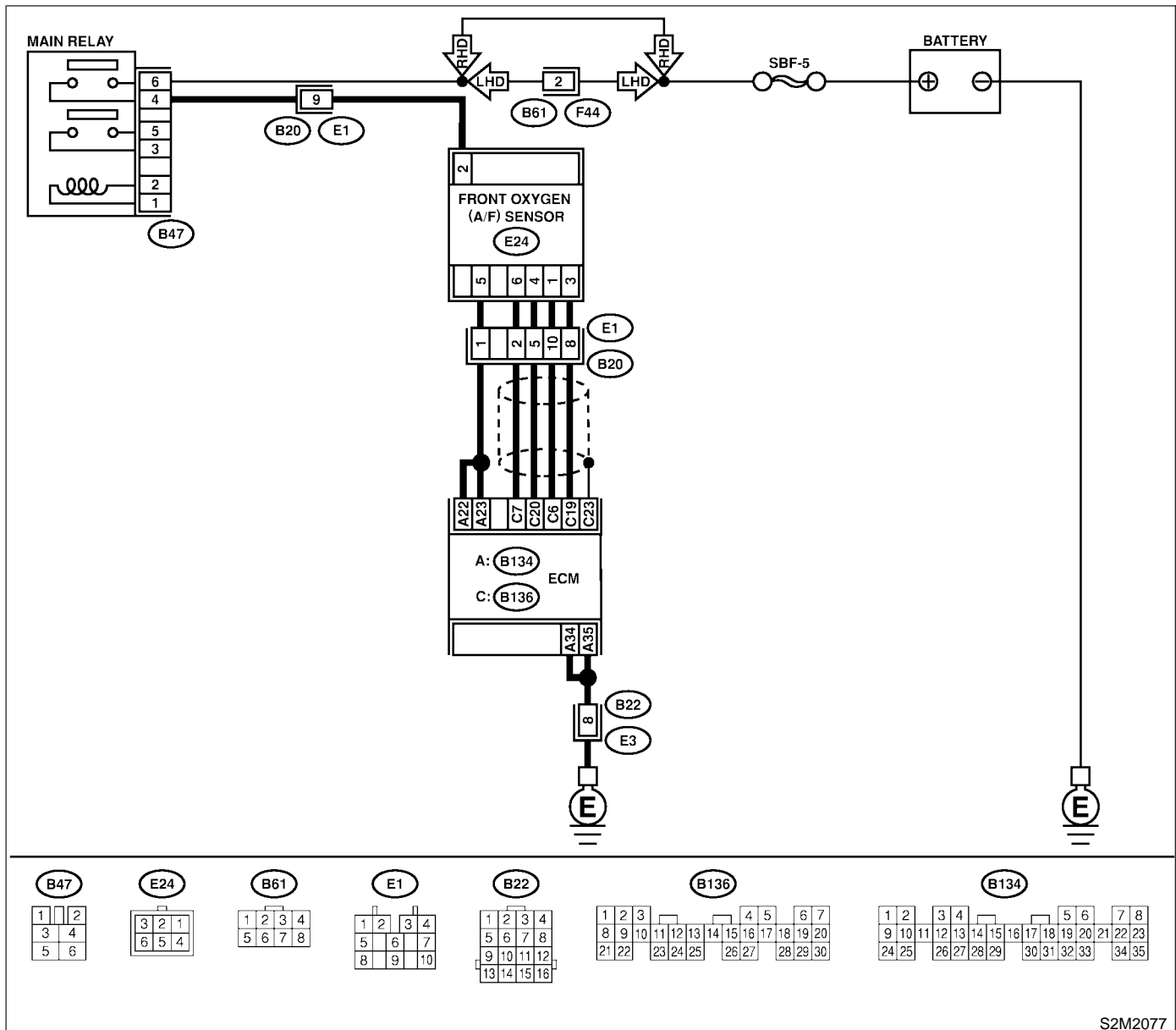

S2M2077



# DIAGNOSTIC PROCEDURE WITH DIAGNOSTIC TROUBLE CODE (DTC)

Engine (Diagnostics)

No.	Step	Check	Yes	No
1	<p><b>CHECK HARNESS BETWEEN ECM AND FRONT OXYGEN (A/F) SENSOR CONNECTOR.</b></p> <p>1) Turn ignition switch to OFF. 2) Disconnect connector from ECM. 3) Measure resistance of harness between ECM connector and chassis ground.</p> <p><b>Connector &amp; terminal</b> <b>(B136) No. 6 — Chassis ground:</b> <b>(B136) No. 7 — Chassis ground:</b> <b>(B136) No. 19 — Chassis ground:</b> <b>(B136) No. 20 — Chassis ground:</b></p>	Is the resistance more than 10 $\Omega$ ?	Replace front oxygen (A/F) sensor. <Ref. to FU(SOHC)-45, Front Oxygen (A/F) Sensor.>	Repair ground short circuit in harness between ECM and front oxygen (A/F) sensor connector.

# DIAGNOSTIC PROCEDURE WITH DIAGNOSTIC TROUBLE CODE (DTC)

Engine (Diagnostics)

## V: DTC P0133 — FRONT OXYGEN (A/F) SENSOR CIRCUIT SLOW RESPONSE —

S058521B26

### ● DTC DETECTING CONDITION:

- Two consecutive driving cycles with fault

### CAUTION:

After repair or replacement of faulty parts, conduct Clear Memory Mode <Ref. to EN(SOHC)-45, OPERATION, Clear Memory Mode.> and Inspection Mode <Ref. to EN(SOHC)-42, OPERATION, Inspection Mode.>.

### ● WIRING DIAGRAM:

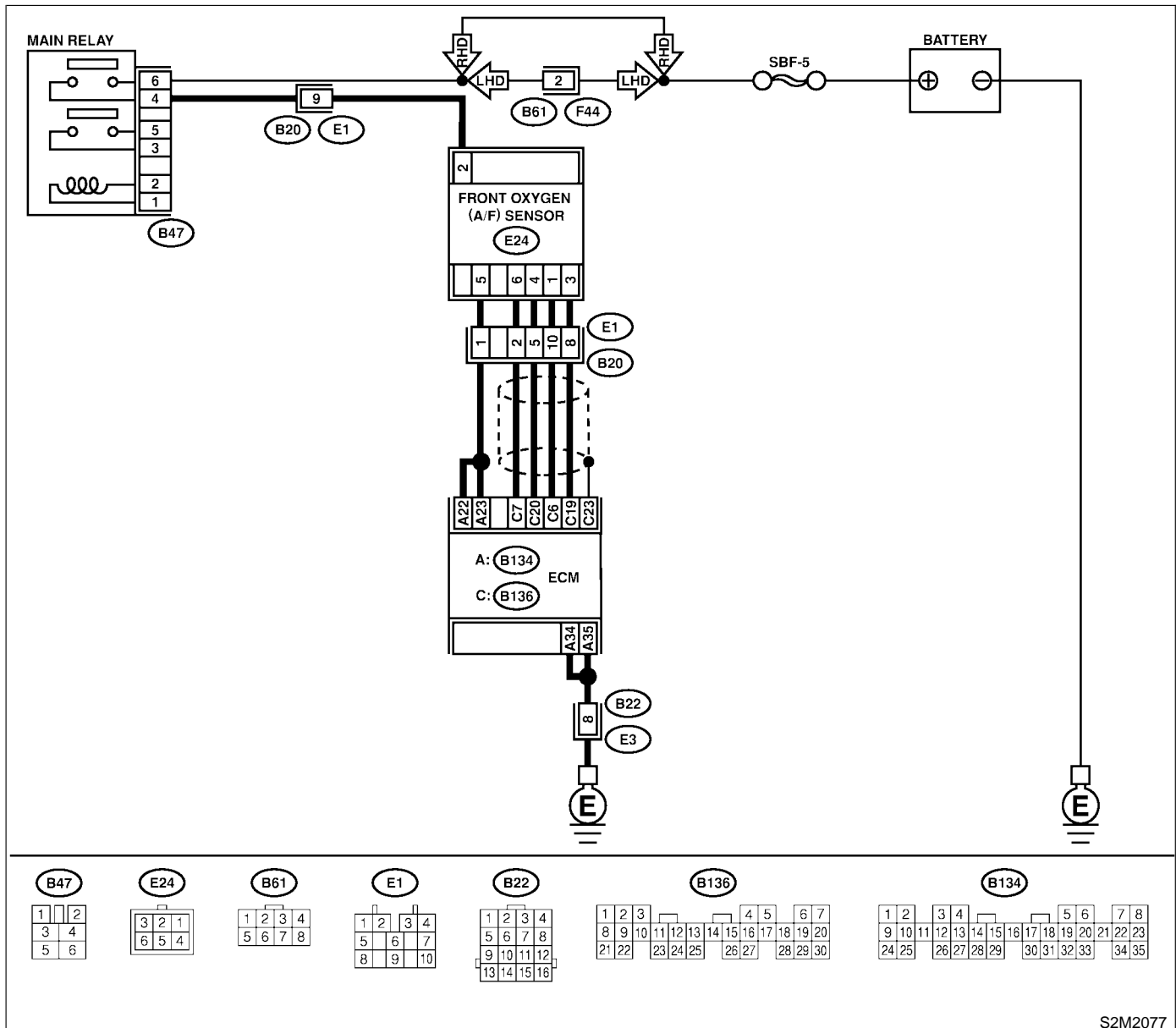

S2M2077

# DIAGNOSTIC PROCEDURE WITH DIAGNOSTIC TROUBLE CODE (DTC)

Engine (Diagnostics)

No.	Step	Check	Yes	No
1	<b>CHECK ANY OTHER DTC ON DISPLAY.</b>	Does the Subaru Select Monitor or OBD-II general scan tool indicate DTC P0131, P0132, P0031 or P0032?	Inspect DTC P0131, P0132, P0031 or P0032 using "17. List of Diagnostic Trouble Code (DTC)". <Ref. to EN(SOHC)-80, List of Diagnostic Trouble Code (DTC).> NOTE: In this case, it is not necessary to inspect DTC P0133.	Go to step 2.
2	<b>CHECK EXHAUST SYSTEM.</b> NOTE: Check the following items. <ul style="list-style-type: none"><li>● Loose installation of front portion of exhaust pipe onto cylinder heads</li><li>● Loose connection between front exhaust pipe and front catalytic converter</li><li>● Damage of exhaust pipe resulting in a hole</li></ul>	Is there a fault in exhaust system?	Repair exhaust system.	Replace front oxygen (A/F) sensor. <Ref. to FU(SOHC)-45, Front Oxygen (A/F) Sensor.>

# DIAGNOSTIC PROCEDURE WITH DIAGNOSTIC TROUBLE CODE (DTC)

Engine (Diagnostics)

## W: DTC P0136 — REAR OXYGEN SENSOR CIRCUIT MALFUNCTION —

S058521B28

### • DTC DETECTING CONDITION:

- Two consecutive driving cycles with fault

### CAUTION:

After repair or replacement of faulty parts, conduct Clear Memory Mode <Ref. to EN(SOHC)-45, OPERATION, Clear Memory Mode.> and Inspection Mode <Ref. to EN(SOHC)-42, OPERATION, Inspection Mode.>.

### • WIRING DIAGRAM:

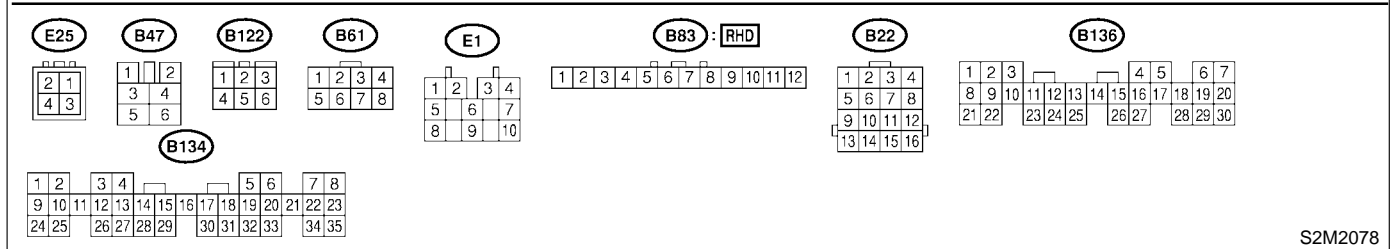
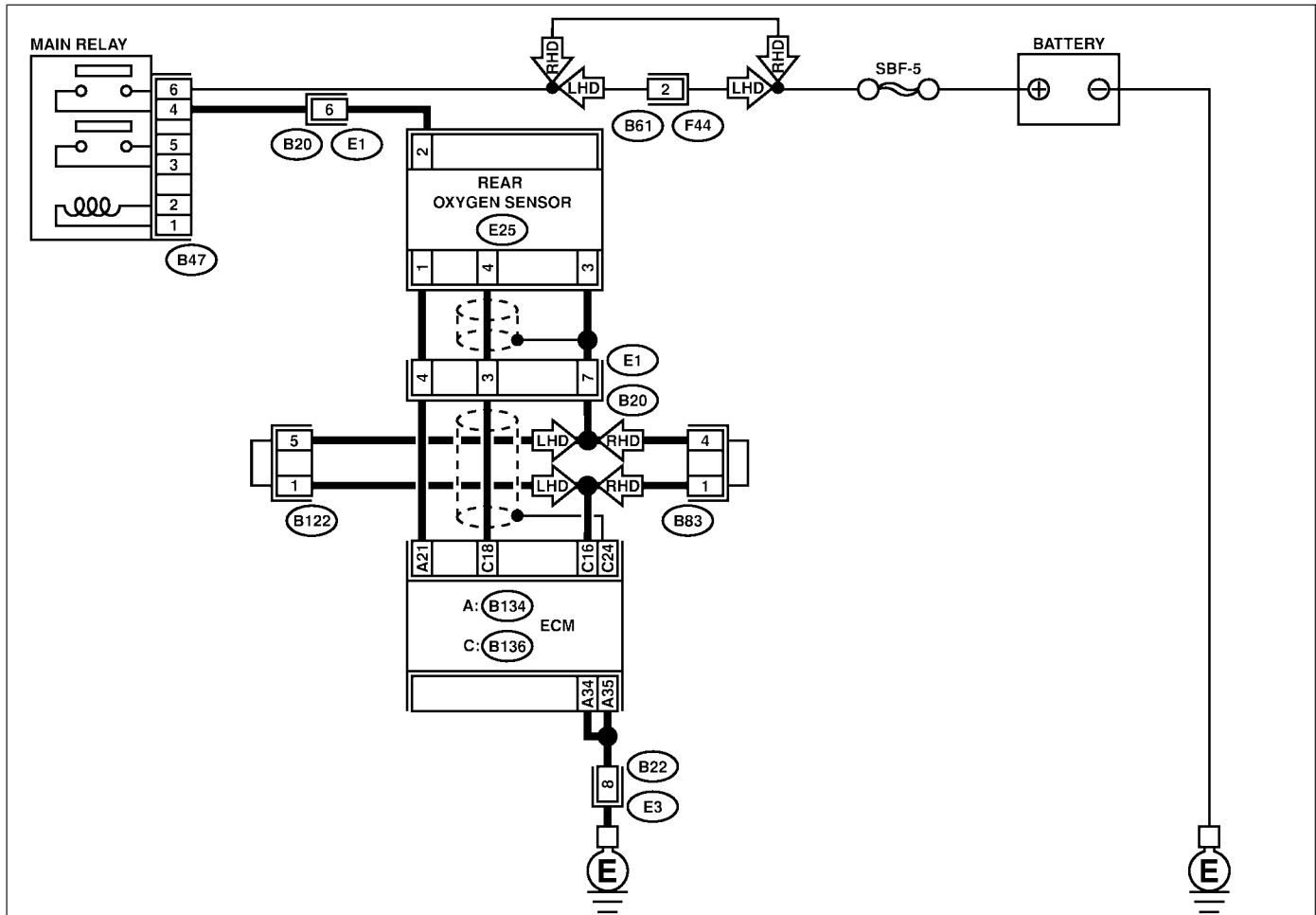

S2M2078

No.	Step	Check	Yes	No
1	CHECK ANY OTHER DTC ON DISPLAY.	Does the Subaru Select Monitor or OBD-II general scan tool indicate DTC P0131 or P0132?	Go to step 2.	Go to step 3.

# DIAGNOSTIC PROCEDURE WITH DIAGNOSTIC TROUBLE CODE (DTC)

Engine (Diagnostics)

No.	Step	Check	Yes	No
2	<p><b>CHECK FAILURE CAUSE OF P0131 or P0132.</b> Inspect DTC P0131 or P0132 using "17. List of Diagnostic Trouble Code (DTC)". &lt;Ref. to EN(SOHC)-80, List of Diagnostic Trouble Code (DTC).&gt;</p>	Is the failure cause of P0131 or P0132 in the fuel system?	Check fuel system. NOTE: In this case, it is not necessary to inspect DTC P0136.	Go to step 3.
3	<p><b>CHECK REAR OXYGEN SENSOR DATA.</b> 1) Warm-up the engine until engine coolant temperature is above 70°C (158°F), and keep the engine speed at 2,000 rpm to 3,000 rpm for two minutes. 2) Read data of rear oxygen sensor signal using Subaru Select Monitor or OBD-II general scan tool. NOTE: ● Subaru Select Monitor For detailed operation procedure, refer to the "READ CURRENT DATA SHOWN ON DISPLAY FOR ENGINE". &lt;Ref. to EN(SOHC)-34, Subaru Select Monitor.&gt; ● OBD-II general scan tool For detailed operation procedures, refer to the OBD-II General Scan Tool Instruction Manual.</p>	Does the value fluctuate?	Go to step 7.	Go to step 4.
4	<p><b>CHECK REAR OXYGEN SENSOR DATA.</b> Read data of rear oxygen sensor signal using Subaru Select Monitor or OBD-II General Scan Tool.</p>	Is the value fixed between 0.2 and 0.4 V?	Go to step 5.	Replace rear oxygen sensor. <Ref. to FU(SOHC)-47, Rear Oxygen Sensor.>
5	<p><b>CHECK HARNESS BETWEEN ECM AND REAR OXYGEN SENSOR CONNECTOR.</b> 1) Turn ignition switch to OFF. 2) Disconnect connectors from ECM and rear oxygen sensor. 3) Measure resistance of harness between ECM and rear oxygen sensor connector. <b>Connector &amp; terminal</b> <b>(B136) No. 16 — (E25) No. 3:</b></p>	Is the resistance more than 3 Ω?	Repair open circuit in harness between ECM and rear oxygen sensor connector.	Go to step 6.
6	<p><b>CHECK HARNESS BETWEEN REAR OXYGEN SENSOR AND ECM CONNECTOR.</b> 1) Turn ignition switch to OFF. 2) Disconnect connector from rear oxygen sensor. 3) Turn ignition switch to ON. 4) Measure voltage between rear oxygen sensor harness connector and engine ground or chassis ground. <b>Connector &amp; terminal</b> <b>(E25) No. 4 (+) — Engine ground (-):</b></p>	Is the voltage more than 0.2 V?	Replace rear oxygen sensor. <Ref. to FU(SOHC)-47, Rear Oxygen Sensor.>	Repair harness and connector. NOTE: In this case, repair the following: ● Open circuit in harness between rear oxygen sensor and ECM connector ● Poor contact in rear oxygen sensor connector ● Poor contact in ECM connector

# DIAGNOSTIC PROCEDURE WITH DIAGNOSTIC TROUBLE CODE (DTC)

Engine (Diagnostics)

No.	Step	Check	Yes	No
7	<b>CHECK EXHAUST SYSTEM.</b> Check exhaust system parts. NOTE: Check the following items. <ul style="list-style-type: none"><li>● Loose installation of portions</li><li>● Damage (crack, hole etc.) of parts</li><li>● Looseness and ill fitting of parts between front oxygen (A/F) sensor and rear oxygen sensor</li></ul>	Is there a fault in exhaust system?	Repair or replace faulty parts.	Replace rear oxygen sensor. <Ref. to FU(SOHC)-47, Rear Oxygen Sensor.>

**MEMO:**

# DIAGNOSTIC PROCEDURE WITH DIAGNOSTIC TROUBLE CODE (DTC)

Engine (Diagnostics)

## X: DTC P0139 — REAR OXYGEN SENSOR CIRCUIT SLOW RESPONSE —

S058521B29

### • DTC DETECTING CONDITION:

- Two consecutive driving cycles with fault

### CAUTION:

After repair or replacement of faulty parts, conduct Clear Memory Mode <Ref. to EN(SOHC)-45, OPERATION, Clear Memory Mode.> and Inspection Mode <Ref. to EN(SOHC)-42, OPERATION, Inspection Mode.>.

### • WIRING DIAGRAM:

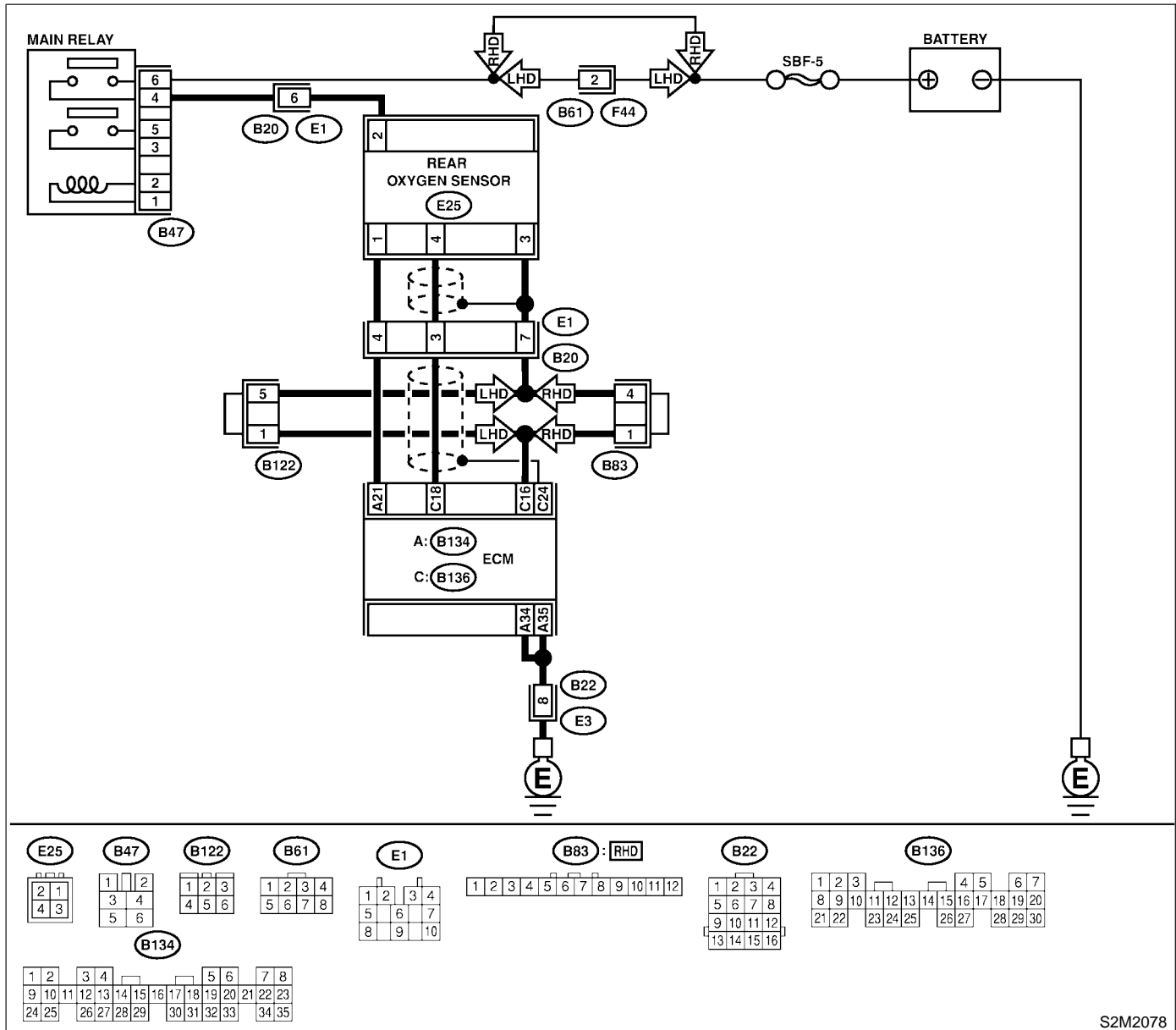

S2M2078



# DIAGNOSTIC PROCEDURE WITH DIAGNOSTIC TROUBLE CODE (DTC)

Engine (Diagnostics)

No.	Step	Check	Yes	No
1	CHECK ANY OTHER DTC ON DISPLAY.	Does the Subaru Select Monitor or OBD-II general scan tool indicate DTC P0136?	Inspect DTC P0136 using "17. List of Diagnostic Trouble Code (DTC)". <Ref. to EN(SOHC)-80, List of Diagnostic Trouble Code (DTC).> NOTE: In this case, it is not necessary to inspect DTC P0139.	Replace rear oxygen sensor. <Ref. to FU(SOHC)-47, Rear Oxygen Sensor.>

# DIAGNOSTIC PROCEDURE WITH DIAGNOSTIC TROUBLE CODE (DTC)

Engine (Diagnostics)

## Y: DTC P0170 — FUEL TRIM MALFUNCTION — S058521B31

- **DTC DETECTING CONDITION:**
  - Two consecutive driving cycles with fault
- **TROUBLE SYMPTOM:**
  - Erroneous idling
  - Engine stalls.
  - Poor driving performance

### CAUTION:

After repair or replacement of faulty parts, conduct Clear Memory Mode <Ref. to EN(SOHC)-45, OPERATION, Clear Memory Mode.> and Inspection Mode <Ref. to EN(SOHC)-42, OPERATION, Inspection Mode.>.

No.	Step	Check	Yes	No
1	<b>CHECK EXHAUST SYSTEM.</b>	Are there holes or loose bolts on exhaust system?	Repair exhaust system.	Go to step 2.
2	<b>CHECK AIR INTAKE SYSTEM.</b>	Are there holes, loose bolts or disconnection of hose on air intake system?	Repair air intake system.	Go to step 3.
3	<b>CHECK FUEL PRESSURE.</b> <b>WARNING:</b> <ul style="list-style-type: none"> <li>● Place “NO FIRE” signs near the working area.</li> <li>● Be careful not to spill fuel on the floor.</li> </ul> 1) Release fuel pressure. <ol style="list-style-type: none"> <li>(1) Disconnect connector from fuel pump relay.</li> <li>(2) Start the engine and run it until it stalls.</li> <li>(3) After the engine stalls, crank it for five more seconds.</li> <li>(4) Turn ignition switch to OFF.</li> </ol> 2) Connect connector to fuel pump relay. 3) Disconnect fuel delivery hose from fuel filter, and connect fuel pressure gauge. 4) Install fuel filler cap. 5) Start the engine and idle while gear position is neutral. 6) Measure fuel pressure while disconnecting pressure regulator vacuum hose from intake manifold. <b>WARNING:</b> Before removing fuel pressure gauge, release fuel pressure. <b>NOTE:</b> If fuel pressure does not increase, squeeze fuel return hose 2 to 3 times, then measure fuel pressure again.	Is fuel pressure between 284 and 314 kPa (2.9 — 3.2 kg/cm <sup>2</sup> , 41 — 46 psi)?	Go to step 4.	Repair the following items. <b>Fuel pressure too high</b> <ul style="list-style-type: none"> <li>● Clogged fuel return line or bent hose</li> </ul> <b>Fuel pressure too low</b> <ul style="list-style-type: none"> <li>● Improper fuel pump discharge</li> <li>● Clogged fuel supply line</li> </ul>

# DIAGNOSTIC PROCEDURE WITH DIAGNOSTIC TROUBLE CODE (DTC)

Engine (Diagnostics)

No.	Step	Check	Yes	No
4	<p><b>CHECK FUEL PRESSURE.</b> After connecting pressure regulator vacuum hose, measure fuel pressure.</p> <p><b>WARNING:</b> <b>Before removing fuel pressure gauge, release fuel pressure.</b></p> <p>NOTE:</p> <ul style="list-style-type: none"> <li>● If fuel pressure does not increase, squeeze fuel return hose 2 to 3 times, then measure fuel pressure again.</li> <li>● If out of specification as measured at this step, check or replace pressure regulator and pressure regulator vacuum hose.</li> </ul>	Is fuel pressure between 206 and 235 kPa (2.1 — 2.4 kg/cm <sup>2</sup> , 30 — 34 psi)?	Go to step 5.	<p>Repair the following items.</p> <p><b>Fuel pressure too high</b></p> <ul style="list-style-type: none"> <li>● Faulty pressure regulator</li> <li>● Clogged fuel return line or bent hose</li> </ul> <p><b>Fuel pressure too low</b></p> <ul style="list-style-type: none"> <li>● Faulty pressure regulator</li> <li>● Improper fuel pump discharge</li> <li>● Clogged fuel supply line</li> </ul>
5	<p><b>CHECK ENGINE COOLANT TEMPERATURE SENSOR.</b></p> <ol style="list-style-type: none"> <li>1) Start the engine and warm-up completely.</li> <li>2) Read data of engine coolant temperature sensor signal using Subaru Select Monitor or OBD-II general scan tool.</li> </ol> <p>NOTE:</p> <ul style="list-style-type: none"> <li>● Subaru Select Monitor For detailed operation procedure, refer to the "READ CURRENT DATA FOR ENGINE". &lt;Ref. to EN(SOHC)-34, Subaru Select Monitor.&gt;</li> <li>● OBD-II general scan tool For detailed operation procedures, refer to the OBD-II General Scan Tool Instruction Manual.</li> </ul>	Is temperature between 70°C (158°F) and 100°C (212°F)?	Go to step 6.	Replace engine coolant temperature sensor. <Ref. to FU(SOHC)-28, Engine Coolant Temperature Sensor.>
6	<p><b>CHECK INTAKE MANIFOLD PRESSURE SENSOR SIGNAL.</b></p> <ol style="list-style-type: none"> <li>1) Start the engine and warm-up engine until coolant temperature is greater than 60°C (140°F).</li> <li>2) Place the selector lever in "N" or "P" position.</li> <li>3) Turn A/C switch to OFF.</li> <li>4) Turn all accessory switches to OFF.</li> <li>5) Read data of intake manifold pressure sensor signal using Subaru Select Monitor or OBD-II general scan tool.</li> </ol> <p>NOTE:</p> <ul style="list-style-type: none"> <li>● Subaru Select Monitor For detailed operation procedure, refer to the "READ CURRENT DATA FOR ENGINE". &lt;Ref. to EN(SOHC)-34, Subaru Select Monitor.&gt;</li> <li>● OBD-II general scan tool For detailed operation procedures, refer to the OBD-II General Scan Tool Instruction Manual.</li> </ul> <p>Specification:</p> <p><b>Idling</b> 24.0 — 41.3 kPa (180 — 310 mmHg, 7.09 — 12.20 inHg)</p> <p><b>Ignition ON</b> 73.3 — 106.6 kPa (550 — 800 mmHg, 21.65 — 31.50 inHg)</p>	Is the voltage within the specifications?	Contact your Subaru distributor. NOTE: Inspection by DTM is required, because probable cause is deterioration of multiple parts.	Replace intake air temperature and pressure sensor. <Ref. to FU(SOHC)-36, Intake Air Temperature and Pressure Sensor.>

# DIAGNOSTIC PROCEDURE WITH DIAGNOSTIC TROUBLE CODE (DTC)

Engine (Diagnostics)

---

## **Z: DTC P0301 — CYLINDER 1 MISFIRE DETECTED —** S058521B37

NOTE:

For the diagnostic procedure, refer to DTC P0304. <Ref. to EN(SOHC)-158, DTC P0304 — CYLINDER 4 MISFIRE DETECTED —, Diagnostic Procedure with Diagnostic Trouble Code (DTC).>

## **AA: DTC P0302 — CYLINDER 2 MISFIRE DETECTED —** S058521B38

NOTE:

For the diagnostic procedure, refer to DTC P0304. <Ref. to EN(SOHC)-158, DTC P0304 — CYLINDER 4 MISFIRE DETECTED —, Diagnostic Procedure with Diagnostic Trouble Code (DTC).>

## **AB: DTC P0303 — CYLINDER 3 MISFIRE DETECTED —** S058521B39

NOTE:

For the diagnostic procedure, refer to DTC P0304. <Ref. to EN(SOHC)-158, DTC P0304 — CYLINDER 4 MISFIRE DETECTED —, Diagnostic Procedure with Diagnostic Trouble Code (DTC).>

**MEMO:**

# DIAGNOSTIC PROCEDURE WITH DIAGNOSTIC TROUBLE CODE (DTC)

Engine (Diagnostics)

## AC: DTC P0304 — CYLINDER 4 MISFIRE DETECTED — S058521B40

### ● DTC DETECTING CONDITION:

- Two consecutive driving cycles with fault
- Immediately at fault recognition (A misfire which could damage catalyst occurs.)

### ● TROUBLE SYMPTOM:

- Engine stalls.
- Erroneous idling
- Rough driving

### CAUTION:

After repair or replacement of faulty parts, conduct Clear Memory Mode <Ref. to EN(SOHC)-45, OPERATION, Clear Memory Mode.> and Inspection Mode <Ref. to EN(SOHC)-42, OPERATION, Inspection Mode.>.

### ● WIRING DIAGRAM:

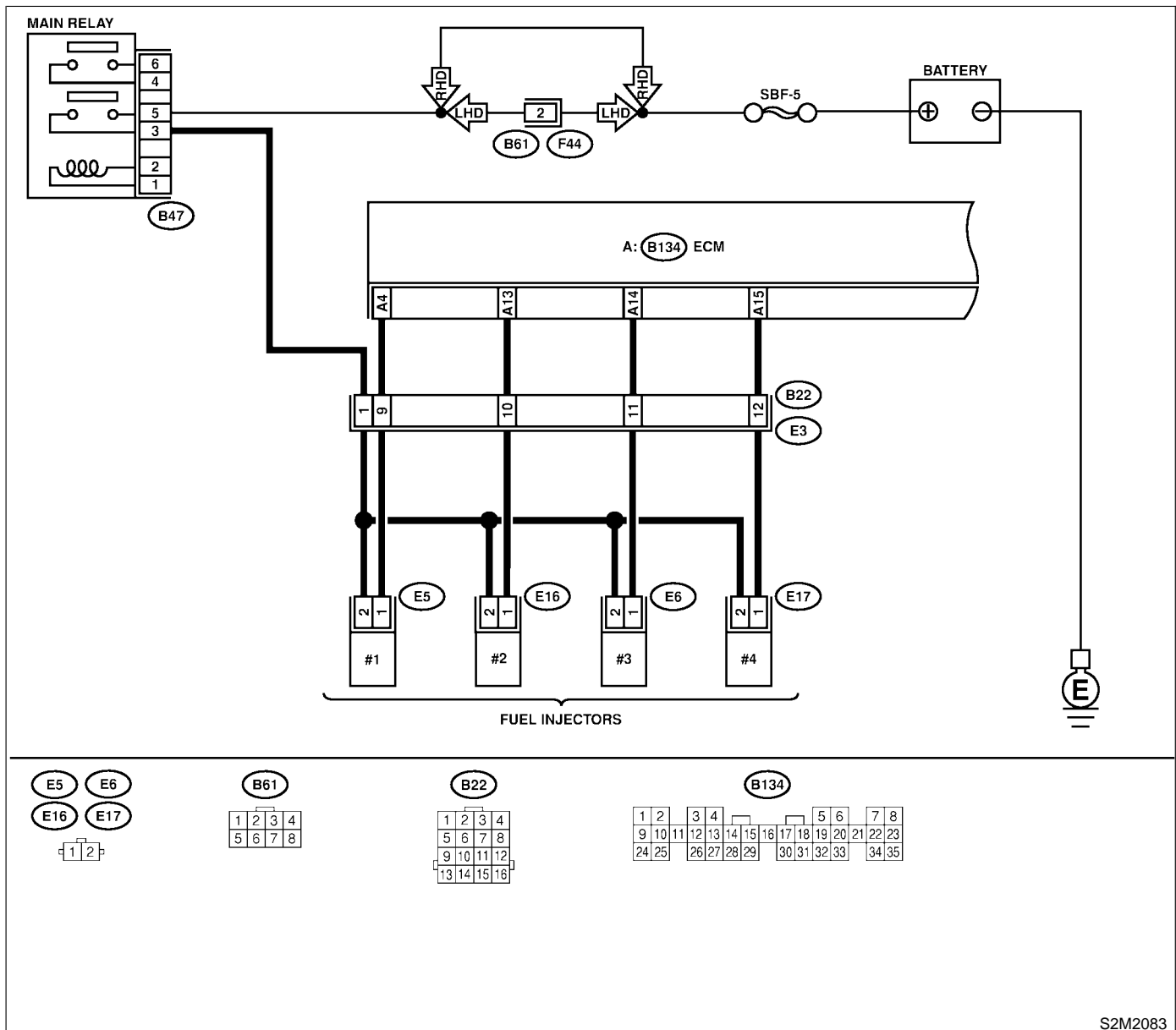

S2M2083

# DIAGNOSTIC PROCEDURE WITH DIAGNOSTIC TROUBLE CODE (DTC)

Engine (Diagnostics)

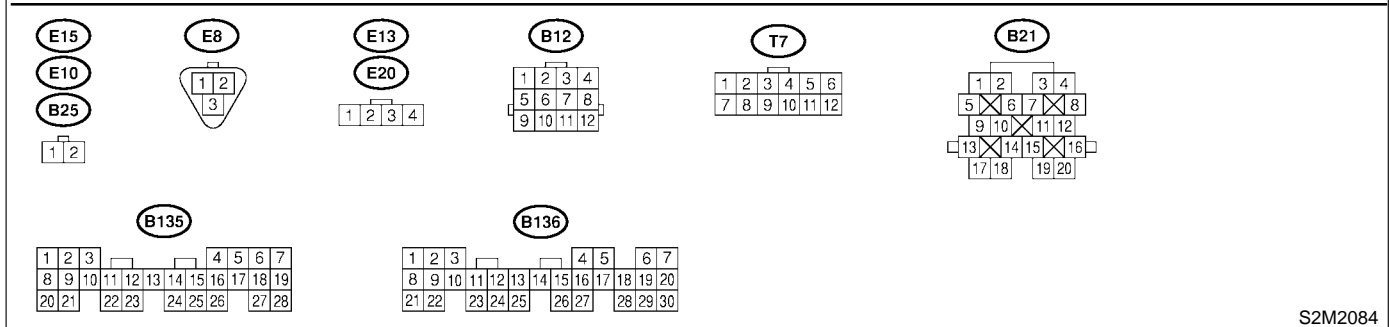
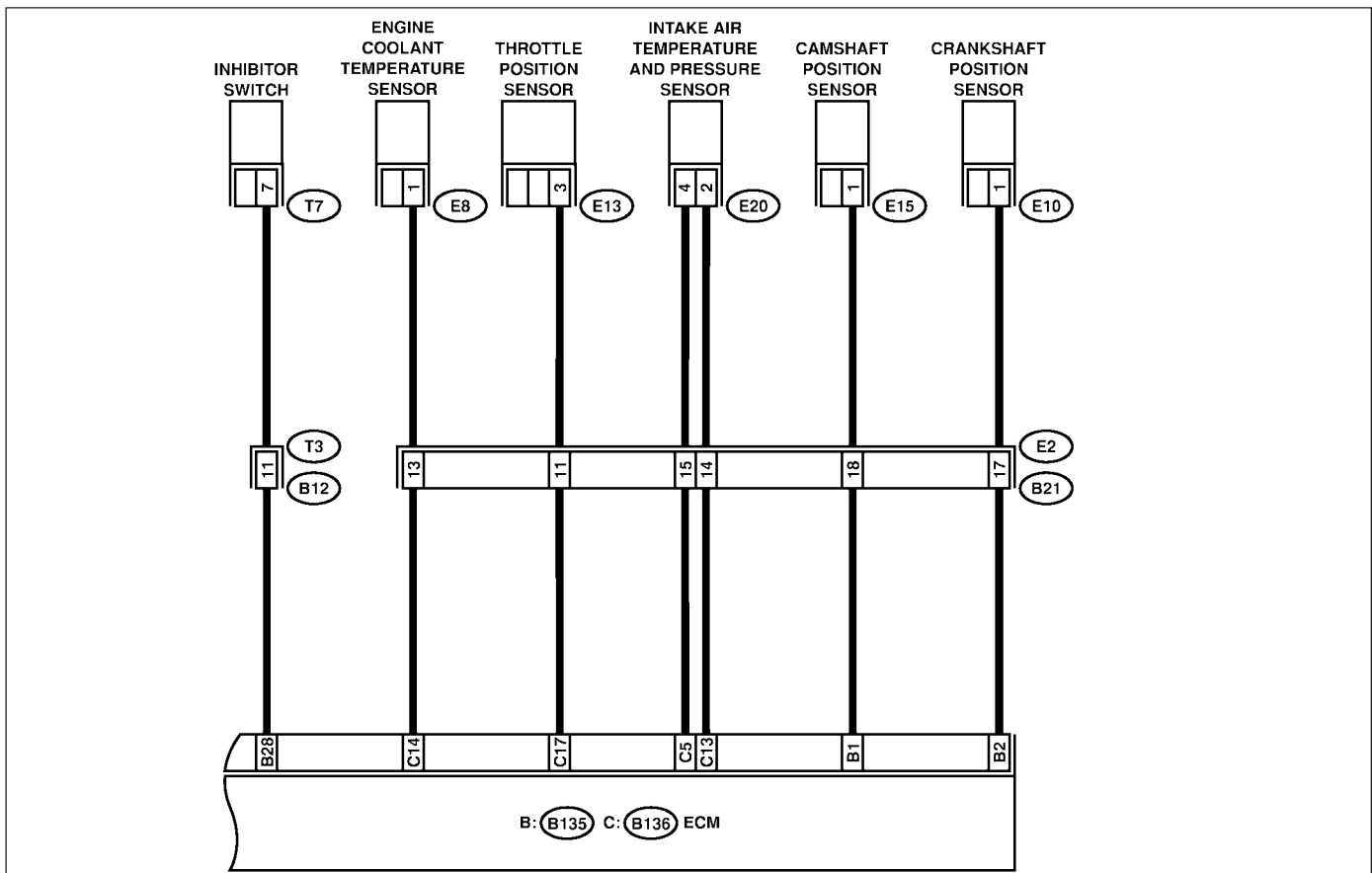

S2M2084

No.	Step	Check	Yes	No
1	<b>CHECK ANY OTHER DTC ON DISPLAY.</b>	Does the Subaru Select Monitor or OBD-II general scan tool indicate DTC P0106, P0107, P0108, P0117, P0118 or P0125?	Inspect DTC P0106, P0107, P0108, P0117, P0118 or P0125 using "17. List of Diagnostic Trouble Code (DTC)". <Ref. to EN(SOHC)-80, List of Diagnostic Trouble Code (DTC).> NOTE: In this case, it is not necessary to inspect DTC P0301, P0302, P0303 and P0304.	Go to step 2.

# DIAGNOSTIC PROCEDURE WITH DIAGNOSTIC TROUBLE CODE (DTC)

Engine (Diagnostics)

No.	Step	Check	Yes	No
2	<p><b>CHECK OUTPUT SIGNAL FROM ECM.</b>                      1) Turn ignition switch to ON.                      2) Measure voltage between ECM connector and chassis ground on faulty cylinders.</p> <p><b>Connector &amp; terminal</b>                      #1 (B134) No. 4 (+) — Chassis ground (-):                      #2 (B134) No. 13 (+) — Chassis ground (-):                      #3 (B134) No. 14 (+) — Chassis ground (-):                      #4 (B134) No. 15 (+) — Chassis ground (-):</p>	Is the voltage more than 10 V?	Go to step 7.	Go to step 3.
3	<p><b>CHECK HARNESS BETWEEN FUEL INJECTOR AND ECM CONNECTOR.</b>                      1) Turn ignition switch to OFF.                      2) Disconnect connector from fuel injector on faulty cylinders.                      3) Measure voltage between ECM connector and engine ground on faulty cylinders.</p> <p><b>Connector &amp; terminal</b>                      #1 (E5) No. 1 — Engine ground:                      #2 (E16) No. 1 — Engine ground:                      #3 (E6) No. 1 — Engine ground:                      #4 (E17) No. 1 — Engine ground:</p>	Is the resistance less than 10 Ω?	Repair ground short circuit in harness between fuel injector and ECM connector.	Go to step 4.
4	<p><b>CHECK HARNESS BETWEEN FUEL INJECTOR AND ECM CONNECTOR.</b>                      Measure resistance of harness connector between ECM connector and fuel injector on faulty cylinders.</p> <p><b>Connector &amp; terminal</b>                      #1 (B134) No. 4 — (E5) No. 1:                      #2 (B134) No. 13 — (E16) No. 1:                      #3 (B134) No. 14 — (E6) No. 1:                      #4 (B134) No. 15 — (E17) No. 1:</p>	Is the resistance less than 1 Ω?	Go to step 5.	Repair harness and connector. NOTE: In this case, repair the following: ● Open circuit in harness between ECM and fuel injector connector ● Poor contact in coupling connector (B22)
5	<p><b>CHECK FUEL INJECTOR.</b>                      Measure resistance between fuel injector terminals on faulty cylinder.</p> <p><b>Terminals</b>                      No. 1 — No. 2:</p>	Is the resistance between 5 and 20 Ω?	Go to step 6.	Replace faulty fuel injector. <Ref. to FU(SOHC)-40, Fuel Injector.>



# DIAGNOSTIC PROCEDURE WITH DIAGNOSTIC TROUBLE CODE (DTC)

Engine (Diagnostics)

No.	Step	Check	Yes	No
6	<p><b>CHECK POWER SUPPLY LINE.</b>                      1) Turn ignition switch to ON.                      2) Measure voltage between fuel injector and engine ground on faulty cylinders.</p> <p><b>Connector &amp; terminal</b>  <b>#1 (E5) No. 2 (+) — Engine ground (-):</b>  <b>#2 (E16) No. 2 (+) — Engine ground (-):</b>  <b>#3 (E6) No. 2 (+) — Engine ground (-):</b>  <b>#4 (E17) No. 2 (+) — Engine ground (-):</b></p>	Is the voltage more than 10 V?	Repair poor contact in all connectors in fuel injector circuit.	Repair harness and connector. NOTE: In this case, repair the following: <ul style="list-style-type: none"> <li>● Open circuit in harness between main relay and fuel injector connector on faulty cylinders</li> <li>● Poor contact in coupling connector</li> <li>● Poor contact in main relay connector</li> <li>● Poor contact in fuel injector connector on faulty cylinders</li> </ul>
7	<p><b>CHECK HARNESS BETWEEN FUEL INJECTOR AND ECM CONNECTOR.</b>                      1) Turn ignition switch to OFF.                      2) Disconnect connector from fuel injector on faulty cylinder.                      3) Turn ignition switch to ON.                      4) Measure voltage between ECM connector and chassis ground on faulty cylinders.</p> <p><b>Connector &amp; terminal</b>  <b>#1 (B134) No. 4 (+) — Chassis ground (-):</b>  <b>#2 (B134) No. 13 (+) — Chassis ground (-):</b>  <b>#3 (B134) No. 14 (+) — Chassis ground (-):</b>  <b>#4 (B134) No. 15 (+) — Chassis ground (-):</b></p>	Is the voltage more than 10 V?	Repair battery short circuit in harness between ECM and fuel injector. After repair, replace ECM. <Ref. to FU(SOHC)-49, Engine Control Module.>	Go to step 8.
8	<p><b>CHECK FUEL INJECTOR.</b>                      1) Turn ignition switch to OFF.                      2) Measure resistance between fuel injector terminals on faulty cylinder.</p> <p><b>Terminals</b>  <b>No. 1 — No. 2:</b></p>	Is the resistance less than 1 Ω?	Replace faulty fuel injector <Ref. to FU(SOHC)-40, Fuel Injector .> and ECM <Ref. to FU(SOHC)-49, Engine Control Module.>.	Go to step 9.
9	<p><b>CHECK INSTALLATION OF CAMSHAFT POSITION SENSOR/CRANKSHAFT POSITION SENSOR.</b></p>	Is camshaft position sensor or crankshaft position sensor loosely installed?	Tighten camshaft position sensor or crankshaft position sensor.	Go to step 10.
10	<p><b>CHECK CRANKSHAFT SPROCKET.</b>                      Remove timing belt cover.</p>	Is crankshaft sprocket rusted or does it have broken teeth?	Replace crankshaft sprocket. <Ref. to ME(SOHC)-53, Crankshaft Sprocket.>	Go to step 11.

# DIAGNOSTIC PROCEDURE WITH DIAGNOSTIC TROUBLE CODE (DTC)

Engine (Diagnostics)

No.	Step	Check	Yes	No
11	<b>CHECK INSTALLATION CONDITION OF TIMING BELT.</b> Turn crankshaft using ST, and align alignment mark on crankshaft sprocket with alignment mark on cylinder block. ST 499987500 CRANKSHAFT SOCKET	Is timing belt dislocated from its proper position?	Repair installation condition of timing belt. <Ref. to ME(SOHC)-46, Timing Belt Assembly.>	Go to step 12.
12	<b>CHECK FUEL LEVEL.</b>	Is the fuel meter indication higher than the "Lower" level?	Go to step 13.	Replenish fuel so fuel meter indication is higher than the "Lower" level. After replenishing fuel, Go to step 13.
13	<b>CHECK STATUS OF CHECK ENGINE MALFUNCTION INDICATOR LAMP (MIL).</b> 1) Clear memory using Subaru Select Monitor. <Ref. to EN(SOHC)-45, Clear Memory Mode.> 2) Start engine, and drive the vehicle more than 10 minutes.	Is the MIL coming on or blinking?	Go to step 15.	Go to step 14.
14	<b>CHECK CAUSE OF MISFIRE DIAGNOSED.</b>	Was the cause of misfire diagnosed when the engine is running?	Finish diagnostics operation, if the engine has no abnormality. NOTE: Ex. Remove spark plug cord, etc.	Repair poor contact. NOTE: In this case, repair the following: <ul style="list-style-type: none"> <li>● Poor contact in ignitor connector</li> <li>● Poor contact in ignition coil connector</li> <li>● Poor contact in fuel injector connector on faulty cylinders</li> <li>● Poor contact in ECM connector</li> <li>● Poor contact in coupling connector</li> </ul>
15	<b>CHECK AIR INTAKE SYSTEM.</b>	Is there a fault in air intake system?	Repair air intake system. NOTE: Check the following items: <ul style="list-style-type: none"> <li>● Are there air leaks or air suction caused by loose or dislocated nuts and bolts?</li> <li>● Are there cracks or any disconnection of hoses?</li> </ul>	Go to step 16.

# DIAGNOSTIC PROCEDURE WITH DIAGNOSTIC TROUBLE CODE (DTC)

Engine (Diagnostics)

No.	Step	Check	Yes	No
16	<b>CHECK MISFIRE SYMPTOM.</b> 1) Turn ignition switch to ON. 2) Read diagnostic trouble code (DTC). ● Subaru Select Monitor <Ref. to EN(SOHC)-34, Subaru Select Monitor.> ● OBD-II general scan tool For detailed operation procedures, refer to the OBD-II General Scan Tool Operation Manual. NOTE: Perform diagnosis according to the items listed below.	Does the Subaru Select Monitor or OBD-II general scan tool indicate only one DTC?	Go to step 21.	Go to step 17.
17	<b>CHECK DIAGNOSTIC TROUBLE CODE (DTC) ON DISPLAY.</b>	Does the Subaru Select Monitor or OBD-II general scan tool indicate DTC P0301 and P0302?	Go to step 22.	Go to step 18.
18	<b>CHECK DIAGNOSTIC TROUBLE CODE (DTC) ON DISPLAY.</b>	Does the Subaru Select Monitor or OBD-II general scan tool indicate DTC P0303 and P0304?	Go to step 23.	Go to step 19.
19	<b>CHECK DIAGNOSTIC TROUBLE CODE (DTC) ON DISPLAY.</b>	Does the Subaru Select Monitor or OBD-II general scan tool indicate DTC P0301 and P0303?	Go to step 24.	Go to step 20.
20	<b>CHECK DIAGNOSTIC TROUBLE CODE (DTC) ON DISPLAY.</b>	Does the Subaru Select Monitor or OBD-II general scan tool indicate DTC P0302 and P0304?	Go to step 25.	Go to step 26.
21	<b>ONLY ONE CYLINDER</b>	Is there a fault in that cylinder?	Repair or replace faulty parts. NOTE: Check the following items. ● Spark plug ● Spark plug cord ● Fuel injector ● Compression ratio	Go to DTC P0170. <Ref. to EN(SOHC)-154, DTC P0170 — FUEL TRIM MALFUNCTION —, Diagnostic Procedure with Diagnostic Trouble Code (DTC).>
22	<b>GROUP OF #1 AND #2 CYLINDERS</b>	Are there faults in #1 and #2 cylinders?	Repair or replace faulty parts. NOTE: ● Check the following items. Spark plugs Fuel injectors Ignition coil Compression ratio ● If no abnormal is discovered, check for "IGNITION CONTROL SYSTEM" of #1 and #2 cylinders side. <Ref. to EN(SOHC)-68, IGNITION CONTROL SYSTEM, Diagnostics for Engine Starting Failure.>	Go to DTC P0170. <Ref. to EN(SOHC)-154, DTC P0170 — FUEL TRIM MALFUNCTION —, Diagnostic Procedure with Diagnostic Trouble Code (DTC).>

# DIAGNOSTIC PROCEDURE WITH DIAGNOSTIC TROUBLE CODE (DTC)

Engine (Diagnostics)

No.	Step	Check	Yes	No
23	<b>GROUP OF #3 AND #4 CYLINDERS</b>	Are there faults in #3 and #4 cylinders?	Repair or replace faulty parts. NOTE: ● Check the following items. Spark plugs Fuel injectors Ignition coil ● If no abnormal is discovered, check for "16. D: IGNITION CONTROL SYSTEM" of #3 and #4 cylinders side. <Ref. to EN(SOHC)-68, IGNITION CONTROL SYSTEM, Diagnostics for Engine Starting Failure.>	Go to DTC P0170. <Ref. to EN(SOHC)-154, DTC P0170 — FUEL TRIM MALFUNCTION —, Diagnostic Procedure with Diagnostic Trouble Code (DTC).>
24	<b>GROUP OF #1 AND #3 CYLINDERS</b>	Are there faults in #1 and #3 cylinders?	Repair or replace faulty parts. NOTE: Check the following items. ● Spark plugs ● Fuel injectors ● Skipping timing belt teeth	Go to DTC P0170. <Ref. to EN(SOHC)-154, DTC P0170 — FUEL TRIM MALFUNCTION —, Diagnostic Procedure with Diagnostic Trouble Code (DTC).>
25	<b>GROUP OF #2 AND #4 CYLINDERS</b>	Are there faults in #2 and #4 cylinders?	Repair or replace faulty parts. NOTE: Check the following items. ● Spark plugs ● Fuel injectors ● Compression ratio ● Skipping timing belt teeth	Go to DTC P0170. <Ref. to EN(SOHC)-154, DTC P0170 — FUEL TRIM MALFUNCTION —, Diagnostic Procedure with Diagnostic Trouble Code (DTC).>
26	<b>CYLINDER AT RANDOM</b>	Is the engine idle rough?	Go to DTC P0170. <Ref. to EN(SOHC)-154, DTC P0170 — FUEL TRIM MALFUNCTION —, Diagnostic Procedure with Diagnostic Trouble Code (DTC).>	Repair or replace faulty parts. NOTE: Check the following items. ● Spark plugs ● Fuel injectors ● Compression ratio

**MEMO:**

# DIAGNOSTIC PROCEDURE WITH DIAGNOSTIC TROUBLE CODE (DTC)

Engine (Diagnostics)

## AD: DTC P0327 — KNOCK SENSOR CIRCUIT LOW INPUT —

S058521F94

- **DTC DETECTING CONDITION:**
  - Immediately at fault recognition
- **TROUBLE SYMPTOM:**
  - Poor driving performance
  - Knocking occurs.

**CAUTION:**

After repair or replacement of faulty parts, conduct Clear Memory Mode <Ref. to EN(SOHC)-45, OPERATION, Clear Memory Mode.> and Inspection Mode <Ref. to EN(SOHC)-42, OPERATION, Inspection Mode.>.

● **WIRING DIAGRAM:**

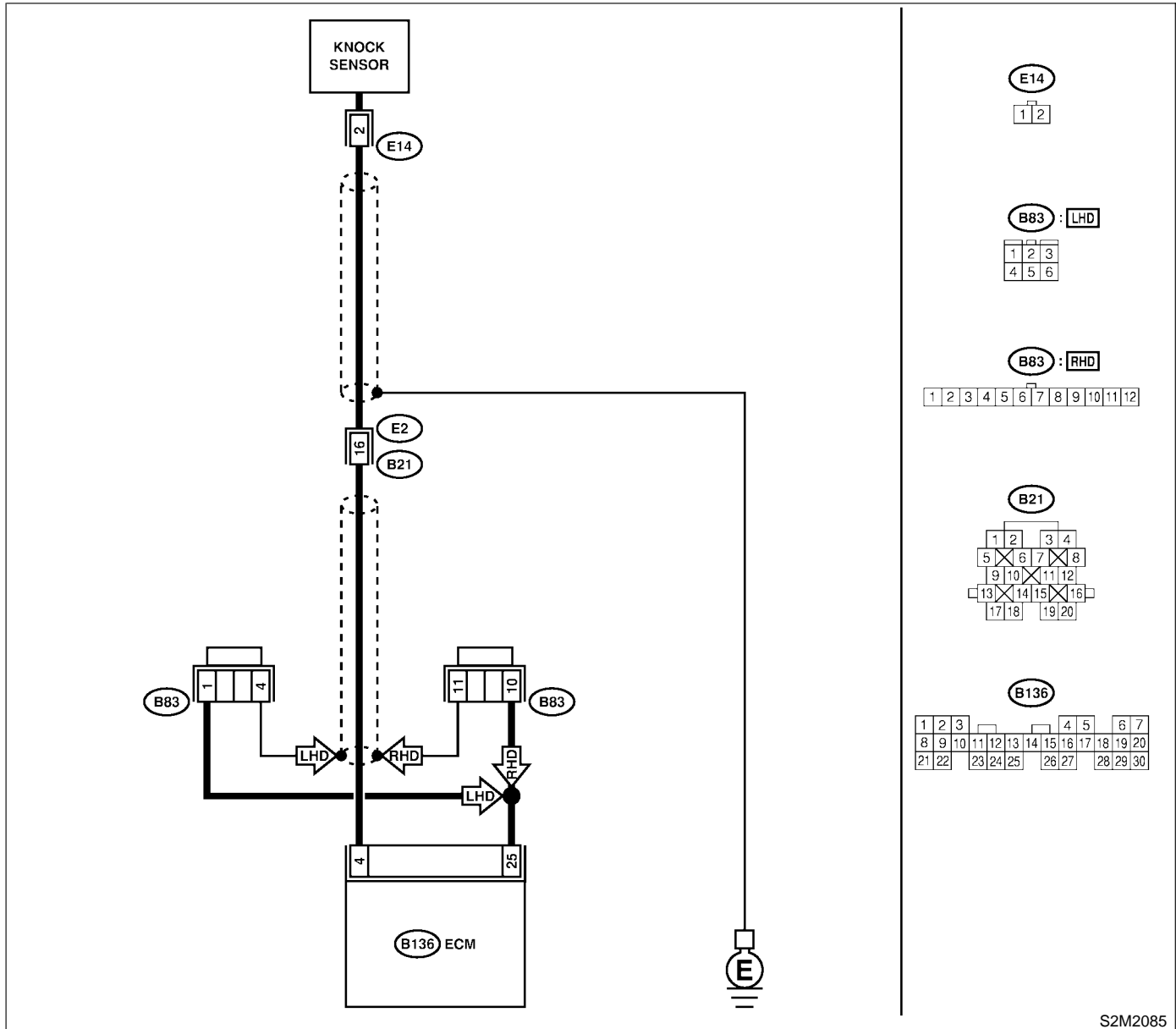

# DIAGNOSTIC PROCEDURE WITH DIAGNOSTIC TROUBLE CODE (DTC)

Engine (Diagnostics)

No.	Step	Check	Yes	No
1	<p><b>CHECK HARNESS BETWEEN KNOCK SENSOR AND ECM CONNECTOR.</b></p> <p>1) Turn ignition switch to OFF.                      2) Disconnect connector from ECM.                      3) Measure resistance between ECM harness connector and chassis ground.</p> <p><b>Connector &amp; terminal</b>  <b>(B136) No. 4 — Chassis ground:</b></p>	Is the resistance more than 700 kΩ?	Go to step 2.	<p>Repair harness and connector.</p> <p><b>NOTE:</b>                      In this case, repair the following:</p> <ul style="list-style-type: none"> <li>● Open circuit in harness between knock sensor and ECM connector</li> <li>● Poor contact in knock sensor connector</li> <li>● Poor contact in coupling connector (B21)</li> </ul>
2	<p><b>CHECK KNOCK SENSOR.</b></p> <p>1) Disconnect connector from knock sensor.                      2) Measure resistance between knock sensor connector terminal and engine ground.</p> <p><b>Terminal</b>  <b>No. 2 — Engine ground:</b></p>	Is the resistance more than 700 kΩ?	Go to step 3.	<p>Repair harness and connector.</p> <p><b>NOTE:</b>                      In this case, repair the following:</p> <ul style="list-style-type: none"> <li>● Open circuit in harness between knock sensor and ECM connector</li> <li>● Poor contact in knock sensor connector</li> <li>● Poor contact in coupling connector (B21)</li> </ul>
3	<p><b>CHECK CONDITION OF KNOCK SENSOR INSTALLATION.</b></p>	Is the knock sensor installation bolt tightened securely?	Replace knock sensor. <Ref. to FU(SOHC)-31, Knock Sensor.>	Tighten knock sensor installation bolt securely.

# DIAGNOSTIC PROCEDURE WITH DIAGNOSTIC TROUBLE CODE (DTC)

Engine (Diagnostics)

## AE: DTC P0328 — KNOCK SENSOR CIRCUIT HIGH INPUT — S058521F95

- **DTC DETECTING CONDITION:**
  - Immediately at fault recognition
- **TROUBLE SYMPTOM:**
  - Poor driving performance
  - Knocking occurs.

**CAUTION:**

After repair or replacement of faulty parts, conduct Clear Memory Mode <Ref. to EN(SOHC)-45, OPERATION, Clear Memory Mode.> and Inspection Mode <Ref. to EN(SOHC)-42, OPERATION, Inspection Mode.>.

● **WIRING DIAGRAM:**

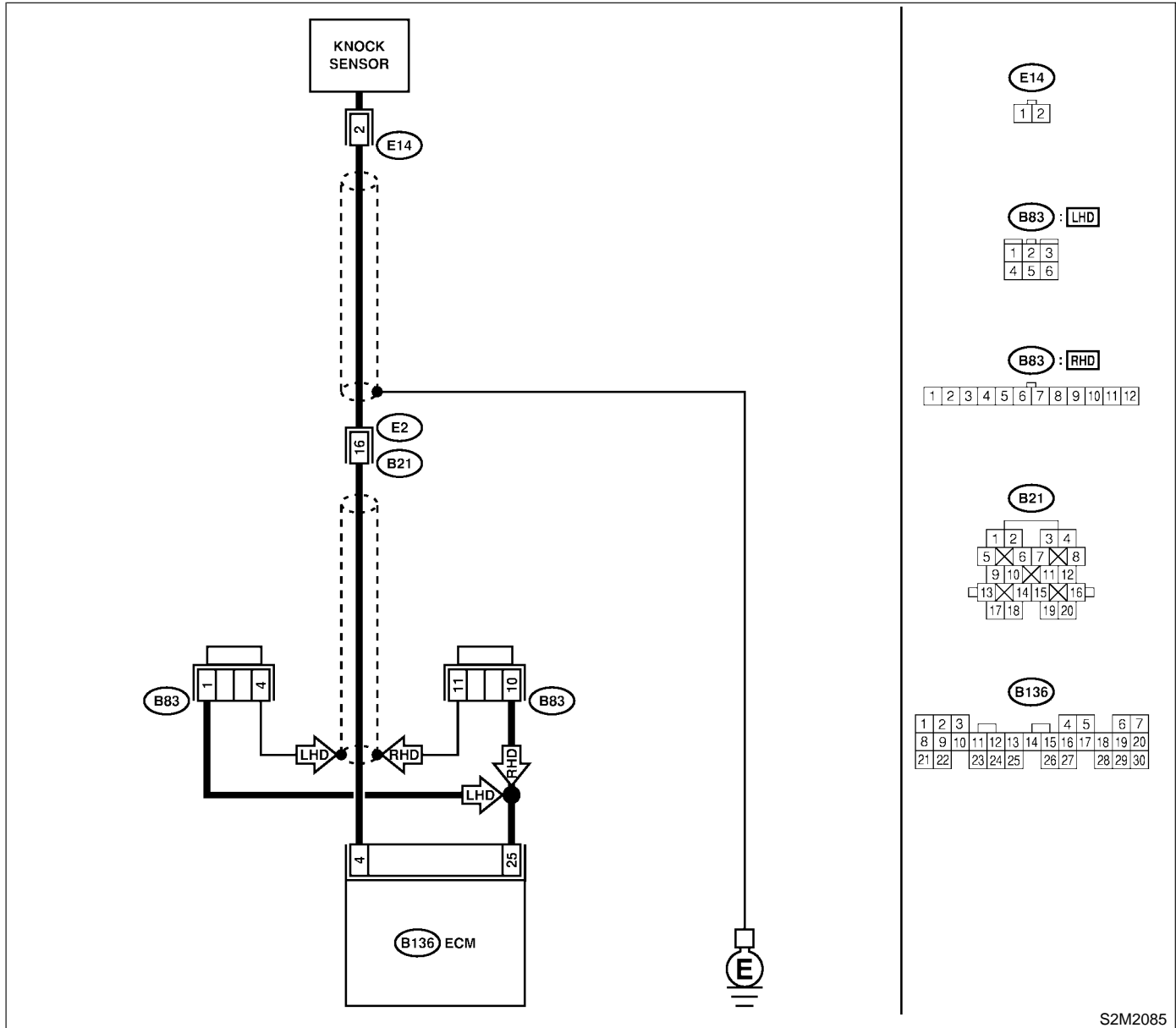



# DIAGNOSTIC PROCEDURE WITH DIAGNOSTIC TROUBLE CODE (DTC)

Engine (Diagnostics)

No.	Step	Check	Yes	No
1	<p><b>CHECK HARNESS BETWEEN KNOCK SENSOR AND ECM CONNECTOR.</b> Measure resistance of harness between ECM connector and chassis ground. <b>Connector &amp; terminal</b> <b>(B136) No. 4 — Chassis ground:</b></p>	Is the resistance less than 400 k $\Omega$ ?	Go to step 2.	Go to step 3.
2	<p><b>CHECK KNOCK SENSOR.</b> 1) Disconnect connector from knock sensor. 2) Measure resistance between knock sensor connector terminal and engine ground. <b>Terminal</b> <b>No. 2 — Engine ground:</b></p>	Is the resistance less than 400 k $\Omega$ ?	Replace knock sensor. <Ref. to FU(SOHC)-31, Knock Sensor.>	Repair ground short circuit in harness between knock sensor connector and ECM connector. NOTE: The harness between both connectors is shielded. Repair short circuit of harness together with shield.
3	<p><b>CHECK INPUT SIGNAL FOR ECM.</b> 1) Connect connectors to ECM and knock sensor. 2) Turn ignition switch to ON. 3) Measure voltage between ECM and chassis ground. <b>Connector &amp; terminal</b> <b>(B136) No. 4 (+) — Chassis ground (-):</b></p>	Is the voltage more than 2 V?	Even if MIL lights up, the circuit has returned to a normal condition at this time. (However, the possibility of poor contact still remains.) NOTE: In this case, repair the following: <ul style="list-style-type: none"> <li>● Poor contact in knock sensor connector</li> <li>● Poor contact in ECM connector</li> <li>● Poor contact in coupling connector (B21)</li> </ul>	Repair poor contact in ECM connector.

# DIAGNOSTIC PROCEDURE WITH DIAGNOSTIC TROUBLE CODE (DTC)

Engine (Diagnostics)

## AF: DTC P0335 — CRANKSHAFT POSITION SENSOR CIRCUIT MALFUNCTION — S058521B42

- **DTC DETECTING CONDITION:**
  - Immediately at fault recognition
- **TROUBLE SYMPTOM:**
  - Engine stalls.
  - Failure of engine to start

### CAUTION:

After repair or replacement of faulty parts, conduct Clear Memory Mode <Ref. to EN(SOHC)-45, OPERATION, Clear Memory Mode.> and Inspection Mode <Ref. to EN(SOHC)-42, OPERATION, Inspection Mode.>.

### ● WIRING DIAGRAM:

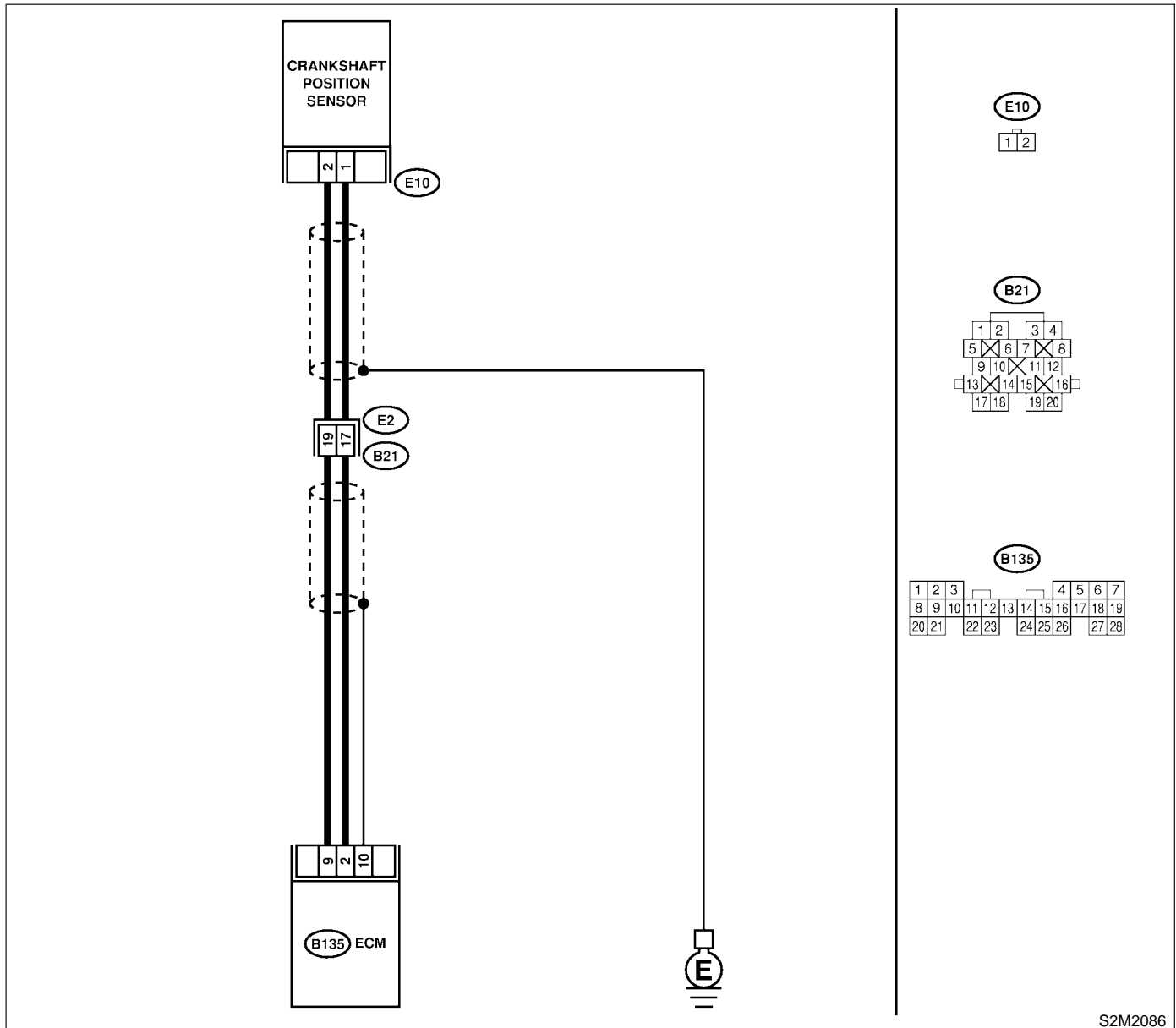

S2M2086

# DIAGNOSTIC PROCEDURE WITH DIAGNOSTIC TROUBLE CODE (DTC)

Engine (Diagnostics)

No.	Step	Check	Yes	No
1	<p><b>CHECK HARNESS BETWEEN CRANKSHAFT POSITION SENSOR AND ECM CONNECTOR.</b></p> <p>1) Turn ignition switch to OFF. 2) Disconnect connector from crankshaft position sensor. 3) Measure resistance of harness between crankshaft position sensor connector and engine ground.</p> <p><b>Connector &amp; terminal</b> <b>(E10) No. 1 — Engine ground:</b></p>	Is the resistance more than 100 k $\Omega$ ?	<p>Repair harness and connector.</p> <p>NOTE: In this case, repair the following:</p> <ul style="list-style-type: none"> <li>● Open circuit in harness between crankshaft position sensor and ECM connector</li> <li>● Poor contact in ECM connector</li> <li>● Poor contact in coupling connector (B21)</li> </ul>	Go to step 2.
2	<p><b>CHECK HARNESS BETWEEN CRANKSHAFT POSITION SENSOR AND ECM CONNECTOR.</b></p> <p>Measure resistance of harness between crankshaft position sensor connector and engine ground.</p> <p><b>Connector &amp; terminal</b> <b>(E10) No. 1 — Engine ground:</b></p>	Is the resistance less than 10 $\Omega$ ?	<p>Repair ground short circuit in harness between crankshaft position sensor and ECM connector.</p> <p>NOTE: The harness between both connectors are shielded. Repair ground short circuit in harness together with shield.</p>	Go to step 3.
3	<p><b>CHECK HARNESS BETWEEN CRANKSHAFT POSITION SENSOR AND ECM CONNECTOR.</b></p> <p>Measure resistance of harness between crankshaft position sensor connector and engine ground.</p> <p><b>Connector &amp; terminal</b> <b>(E10) No. 2 — Engine ground:</b></p>	Is the resistance less than 5 $\Omega$ ?	Go to step 4.	<p>Repair harness and connector.</p> <p>NOTE: In this case, repair the following:</p> <ul style="list-style-type: none"> <li>● Open circuit in harness between crankshaft position sensor and ECM connector</li> <li>● Poor contact in ECM connector</li> <li>● Poor contact in coupling connector (B21)</li> </ul>
4	<p><b>CHECK CONDITION OF CRANKSHAFT POSITION SENSOR.</b></p>	Is the crankshaft position sensor installation bolt tightened securely?	Go to step 5.	Tighten crankshaft position sensor installation bolt securely.
5	<p><b>CHECK CRANKSHAFT POSITION SENSOR.</b></p> <p>1) Remove crankshaft position sensor. 2) Measure resistance between connector terminals of crankshaft position sensor.</p> <p><b>Terminals</b> <b>No. 1 — No. 2:</b></p>	Is the resistance between 1 and 4 k $\Omega$ ?	Repair poor contact in crankshaft position sensor connector.	Replace crankshaft position sensor. <Ref. to FU(SOHC)-29, Crankshaft Position Sensor.>

# DIAGNOSTIC PROCEDURE WITH DIAGNOSTIC TROUBLE CODE (DTC)

Engine (Diagnostics)

## AG: DTC P0336 — CRANKSHAFT POSITION SENSOR CIRCUIT RANGE/PERFORMANCE PROBLEM —

S058521B43

- **DTC DETECTING CONDITION:**
  - Immediately at fault recognition
- **TROUBLE SYMPTOM:**
  - Engine stalls.
  - Failure of engine to start

### CAUTION:

After repair or replacement of faulty parts, conduct Clear Memory Mode <Ref. to EN(SOHC)-45, OPERATION, Clear Memory Mode.> and Inspection Mode <Ref. to EN(SOHC)-42, OPERATION, Inspection Mode.>.

- **WIRING DIAGRAM:**

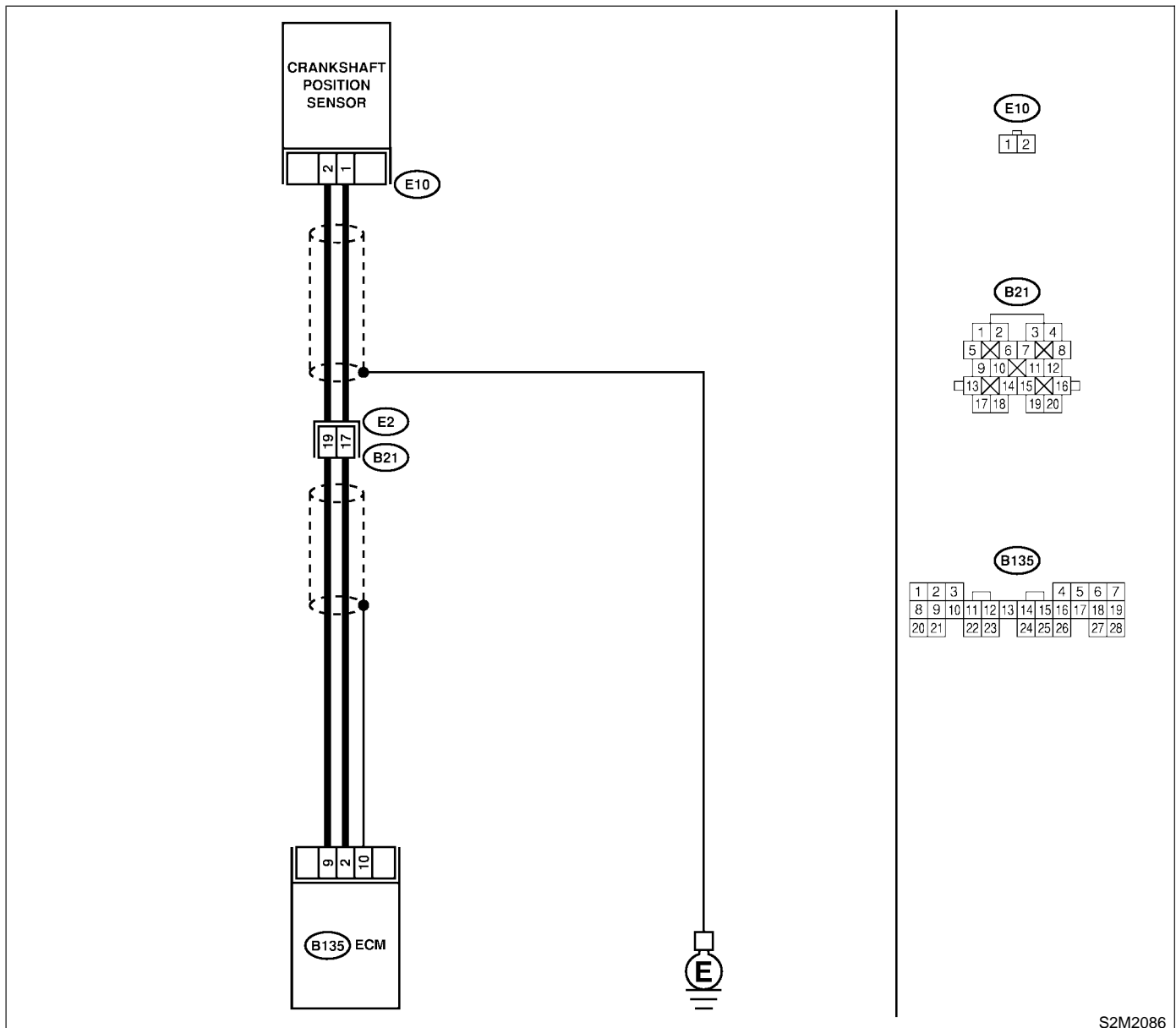

S2M2086

# DIAGNOSTIC PROCEDURE WITH DIAGNOSTIC TROUBLE CODE (DTC)

Engine (Diagnostics)

No.	Step	Check	Yes	No
1	<b>CHECK ANY OTHER DTC ON DISPLAY.</b>	Does the Subaru Select Monitor or OBD-II general scan tool indicate DTC P0335?	Inspect DTC P0335 using "17. List of Diagnostic Trouble Code (DTC)". <Ref. to EN(SOHC)-80, List of Diagnostic Trouble Code (DTC).>	Go to step 2.
2	<b>CHECK CONDITION OF CRANKSHAFT POSITION SENSOR.</b> Turn ignition switch to OFF.	Is the crankshaft position sensor installation bolt tightened securely?	Go to step 3.	Tighten crankshaft position sensor installation bolt securely.
3	<b>CHECK CRANKSHAFT SPROCKET.</b> Remove front belt cover.	Are crankshaft sprocket teeth cracked or damaged?	Replace crankshaft sprocket. <Ref. to ME(SOHC)-46, Crankshaft Sprocket.>	Go to step 4.
4	<b>CHECK INSTALLATION CONDITION OF TIMING BELT.</b> Turn crankshaft using ST, and align alignment mark on crankshaft sprocket with alignment mark on cylinder block. ST 499987500 CRANKSHAFT SOCKET	Is timing belt dislocated from its proper position?	Repair installation condition of timing belt. <Ref. to ME(SOHC)-46, Timing Belt Assembly.>	Replace crankshaft position sensor. <Ref. to FU(SOHC)-29, Crankshaft Position Sensor.>

# DIAGNOSTIC PROCEDURE WITH DIAGNOSTIC TROUBLE CODE (DTC)

Engine (Diagnostics)

## AH: DTC P0340 — CAMSHAFT POSITION SENSOR CIRCUIT MALFUNCTION

S058521B44

- **DTC DETECTING CONDITION:**
  - Immediately at fault recognition
- **TROUBLE SYMPTOM:**
  - Engine stalls.
  - Failure of engine to start

### CAUTION:

After repair or replacement of faulty parts, conduct Clear Memory Mode <Ref. to EN(SOHC)-45, OPERATION, Clear Memory Mode.> and Inspection Mode <Ref. to EN(SOHC)-42, OPERATION, Inspection Mode.>.

- **WIRING DIAGRAM:**

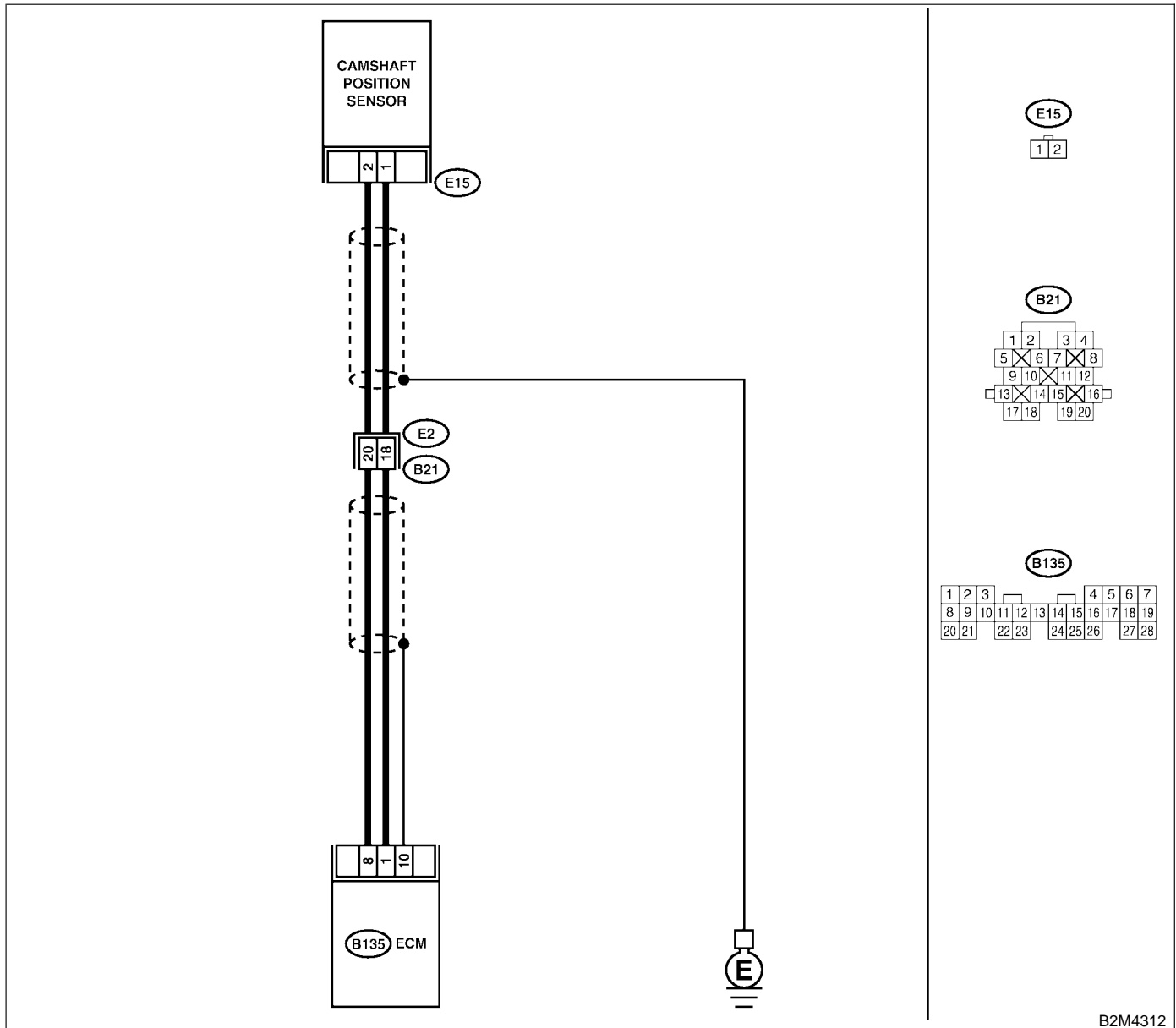

B2M4312

# DIAGNOSTIC PROCEDURE WITH DIAGNOSTIC TROUBLE CODE (DTC)

Engine (Diagnostics)

No.	Step	Check	Yes	No
1	<p><b>CHECK HARNESS BETWEEN CAMSHAFT POSITION SENSOR AND ECM CONNECTOR.</b></p> <p>1) Turn ignition switch to OFF. 2) Disconnect connector from camshaft position sensor. 3) Measure resistance of harness between camshaft position sensor connector and engine ground.</p> <p><b>Connector &amp; terminal</b> <b>(E15) No. 1 — Engine ground:</b></p>	Is the resistance more than 100 k $\Omega$ ?	<p>Repair harness and connector.</p> <p>NOTE: In this case, repair the following:</p> <ul style="list-style-type: none"> <li>● Open circuit in harness between camshaft position sensor and ECM connector</li> <li>● Poor contact in ECM connector</li> <li>● Poor contact in coupling connector (B21)</li> </ul>	Go to step 2.
2	<p><b>CHECK HARNESS BETWEEN CAMSHAFT POSITION SENSOR AND ECM CONNECTOR.</b></p> <p>Measure resistance of harness between camshaft position sensor connector and engine ground.</p> <p><b>Connector &amp; terminal</b> <b>(E15) No. 1 — Engine ground:</b></p>	Is the resistance less than 10 $\Omega$ ?	<p>Repair ground short circuit in harness between camshaft position sensor and ECM connector.</p> <p>NOTE: The harness between both connectors are shielded. Repair ground short circuit in harness together with shield.</p>	Go to step 3.
3	<p><b>CHECK HARNESS BETWEEN CAMSHAFT POSITION SENSOR AND ECM CONNECTOR.</b></p> <p>Measure resistance of harness between camshaft position sensor connector and engine ground.</p> <p><b>Connector &amp; terminal</b> <b>(E15) No. 2 — Engine ground:</b></p>	Is the resistance less than 5 $\Omega$ ?	Go to step 4.	<p>Repair harness and connector.</p> <p>NOTE: In this case, repair the following:</p> <ul style="list-style-type: none"> <li>● Open circuit in harness between camshaft position sensor and ECM connector</li> <li>● Poor contact in ECM connector</li> <li>● Poor contact in coupling connector (B21)</li> </ul>
4	<p><b>CHECK CONDITION OF CAMSHAFT POSITION SENSOR.</b></p>	Is the camshaft position sensor installation bolt tightened securely?	Go to step 5.	Tighten camshaft position sensor installation bolt securely.
5	<p><b>CHECK CAMSHAFT POSITION SENSOR.</b></p> <p>1) Remove camshaft position sensor. 2) Measure resistance between connector terminals of camshaft position sensor.</p> <p><b>Terminals</b> <b>No. 1 — No. 2:</b></p>	Is the resistance between 1 and 4 k $\Omega$ ?	Repair poor contact in camshaft position sensor connector.	Replace camshaft position sensor. <Ref. to FU(SOHC)-30, Camshaft Position Sensor.>

# DIAGNOSTIC PROCEDURE WITH DIAGNOSTIC TROUBLE CODE (DTC)

Engine (Diagnostics)

## AI: DTC P0341 — CAMSHAFT POSITION SENSOR CIRCUIT RANGE/PERFORMANCE PROBLEM —

S058521B45

- **DTC DETECTING CONDITION:**
  - Immediately at fault recognition
- **TROUBLE SYMPTOM:**
  - Engine stalls.
  - Failure of engine to start

### CAUTION:

After repair or replacement of faulty parts, conduct Clear Memory Mode <Ref. to EN(SOHC)-45, OPERATION, Clear Memory Mode.> and Inspection Mode <Ref. to EN(SOHC)-42, OPERATION, Inspection Mode.>.

- **WIRING DIAGRAM:**

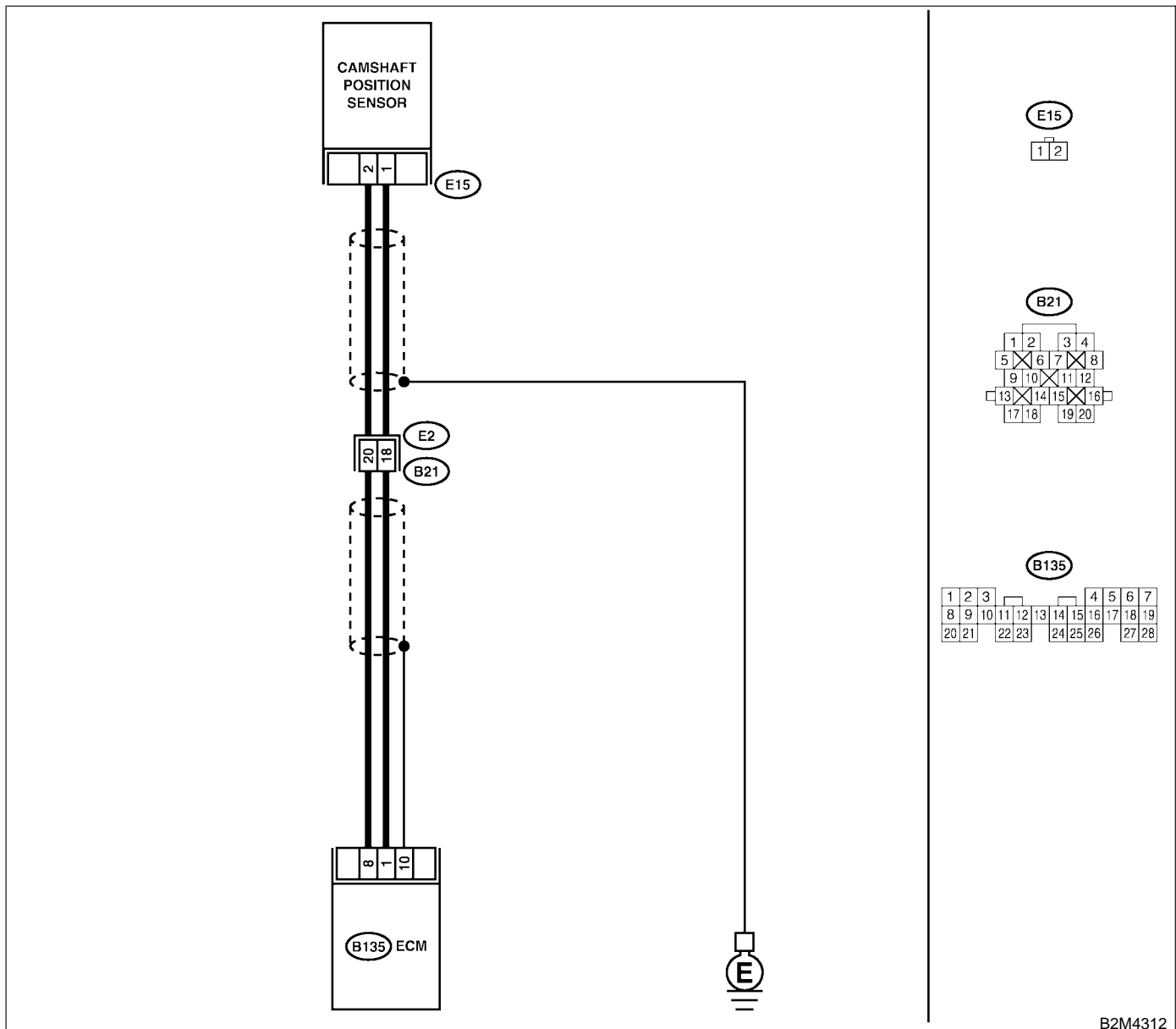

B2M4312



# DIAGNOSTIC PROCEDURE WITH DIAGNOSTIC TROUBLE CODE (DTC)

Engine (Diagnostics)

No.	Step	Check	Yes	No
1	<b>CHECK ANY OTHER DTC ON DISPLAY.</b>	Does the Subaru Select Monitor or OBD-II general scan tool indicate DTC P0340?	Inspect DTC P0340 using "17. List of Diagnostic Trouble Code (DTC)". <Ref. to EN(SOHC)-80, List of Diagnostic Trouble Code (DTC).>	Go to step 2.
2	<b>CHECK HARNESS BETWEEN CAMSHAFT POSITION SENSOR AND ECM CONNECTOR.</b> 1) Turn ignition switch to OFF. 2) Disconnect connector from camshaft position sensor. 3) Measure resistance of harness between camshaft position sensor connector and engine ground. <b>Connector &amp; terminal</b> <b>(E15) No. 1 — Engine ground:</b>	Is the resistance more than 100 kΩ?	Repair harness and connector. NOTE: In this case, repair the following: ● Open circuit in harness between camshaft position sensor and ECM connector ● Poor contact in ECM connector ● Poor contact in coupling connector (B21)	Go to step 3.
3	<b>CHECK HARNESS BETWEEN CAMSHAFT POSITION SENSOR AND ECM CONNECTOR.</b> Measure resistance of harness between camshaft position sensor connector and engine ground. <b>Connector &amp; terminal</b> <b>(E15) No. 1 — Engine ground:</b>	Is the resistance less than 10 Ω?	Repair ground short circuit in harness between camshaft position sensor and ECM connector. NOTE: The harness between both connectors are shielded. Repair ground short circuit in harness together with shield.	Go to step 4.
4	<b>CHECK HARNESS BETWEEN CAMSHAFT POSITION SENSOR AND ECM CONNECTOR.</b> Measure resistance of harness between camshaft position sensor connector and engine ground. <b>Connector &amp; terminal</b> <b>(E15) No. 2 — Engine ground:</b>	Is the resistance less than 5 Ω?	Go to step 5.	Repair harness and connector. NOTE: In this case, repair the following: ● Open circuit in harness between camshaft position sensor and ECM connector ● Poor contact in ECM connector ● Poor contact in coupling connector (B21)
5	<b>CHECK CONDITION OF CAMSHAFT POSITION SENSOR.</b>	Is the camshaft position sensor installation bolt tightened securely?	Go to step 6.	Tighten camshaft position sensor installation bolt securely.

# DIAGNOSTIC PROCEDURE WITH DIAGNOSTIC TROUBLE CODE (DTC)

Engine (Diagnostics)

No.	Step	Check	Yes	No
6	<b>CHECK CAMSHAFT POSITION SENSOR.</b> 1) Remove camshaft position sensor. 2) Measure resistance between connector terminals of camshaft position sensor. <i>Terminals</i> <i>No. 1 — No. 2:</i>	Is the resistance between 1 and 4 kΩ?	Go to step 7.	Replace camshaft position sensor. <Ref. to FU(SOHC)-30, Camshaft Position Sensor.>
7	<b>CHECK CONDITION OF CAMSHAFT POSITION SENSOR.</b> Turn ignition switch to OFF.	Is the camshaft position sensor installation bolt tightened securely?	Go to step 8.	Tighten camshaft position sensor installation bolt securely.
8	<b>CHECK CAMSHAFT SPROCKET.</b> Remove front belt cover. <Ref. to ME(SOHC)-45, Belt Cover.>	Are camshaft sprocket teeth cracked or damaged?	Replace camshaft sprocket. <Ref. to ME(SOHC)-51, Camshaft Sprocket.>	Go to step 9.
9	<b>CHECK INSTALLATION CONDITION OF TIMING BELT.</b> Turn camshaft using ST, and align alignment mark on camshaft sprocket with alignment mark on timing belt cover LH. ST 499207100 CAMSHAFT SPROCKET WRENCH	Is timing belt dislocated from its proper position?	Repair installation condition of timing belt. <Ref. to ME(SOHC)-46, Timing Belt Assembly.>	Replace camshaft position sensor. <Ref. to FU(SOHC)-30, Camshaft Position Sensor.>

**MEMO:**

# DIAGNOSTIC PROCEDURE WITH DIAGNOSTIC TROUBLE CODE (DTC)

Engine (Diagnostics)

## AJ: DTC P0420 — CATALYST SYSTEM EFFICIENCY BELOW THRESHOLD —

S058521B46

- **DTC DETECTING CONDITION:**
  - Two consecutive driving cycles with fault
- **TROUBLE SYMPTOM:**
  - Engine stalls.
  - Idle mixture is out of specifications.

**CAUTION:**

After repair or replacement of faulty parts, conduct Clear Memory Mode <Ref. to EN(SOHC)-45, OPERATION, Clear Memory Mode.> and Inspection Mode <Ref. to EN(SOHC)-42, OPERATION, Inspection Mode.>.

● **WIRING DIAGRAM:**

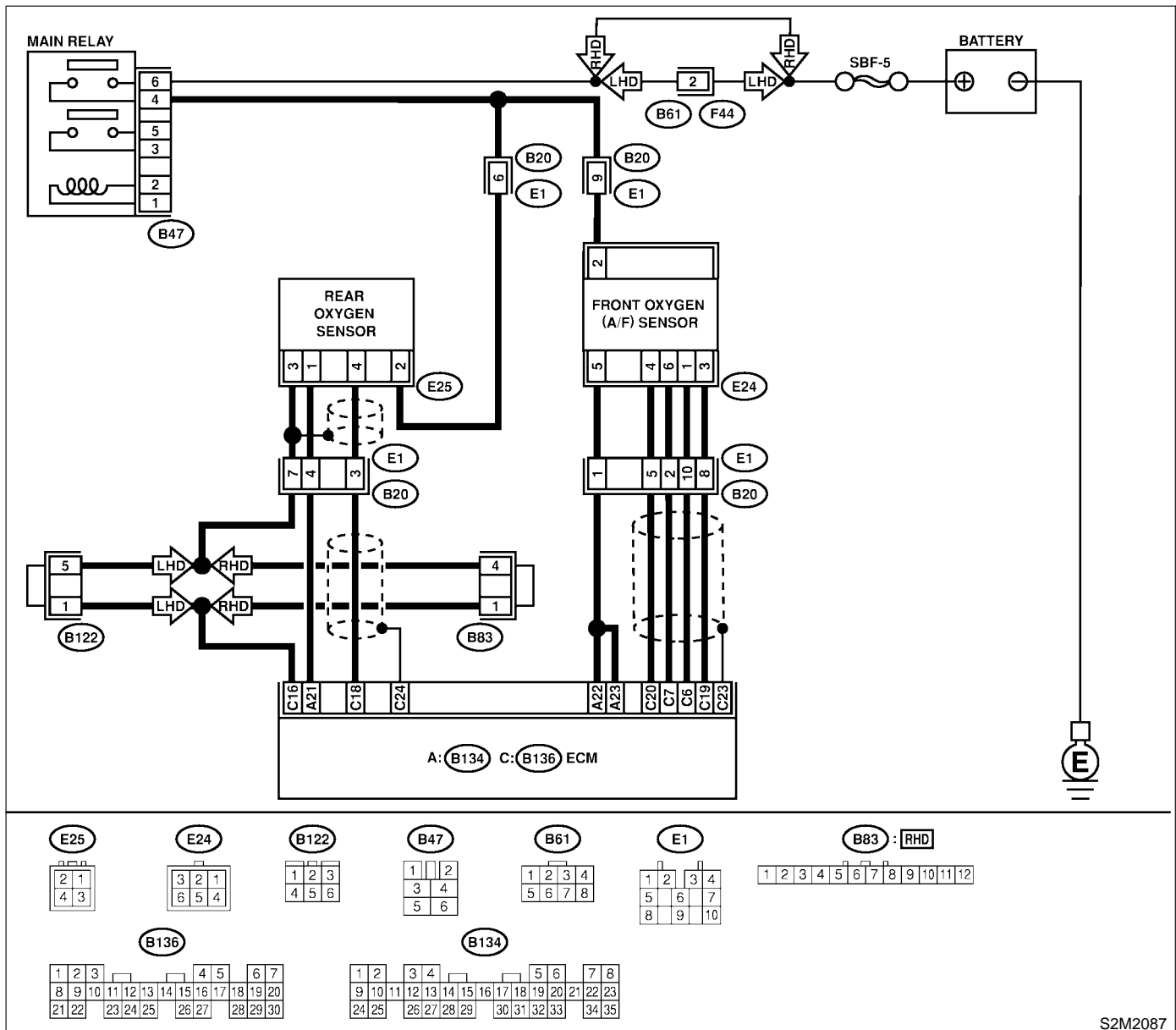

S2M2087

# DIAGNOSTIC PROCEDURE WITH DIAGNOSTIC TROUBLE CODE (DTC)

Engine (Diagnostics)

No.	Step	Check	Yes	No
1	<b>CHECK ANY OTHER DTC ON DISPLAY.</b>	Does the Subaru Select Monitor or OBD-II general scan tool indicate DTC P0130, P0133, P0136, P0139, P0037, P0301, P0302, P0303, P0304, P1130, P1131, P0031, P0032 and P0038?	Inspect the relevant DTC using "17. List of Diagnostic Trouble Code (DTC)". <Ref. to EN(SOHC)-80, List of Diagnostic Trouble Code (DTC).> NOTE: In this case, it is not necessary to inspect DTC P0420.	Go to step 2.
2	<b>CHECK EXHAUST SYSTEM.</b> Check for gas leaks or air suction caused by loose or dislocated nuts and bolts, and open hole at exhaust pipes. NOTE: Check the following positions. ● Between cylinder head and front exhaust pipe ● Between front exhaust pipe and front catalytic converter ● Between front catalytic converter and rear catalytic converter	Is there a fault in exhaust system?	Repair or replace exhaust system. <Ref. to EX(SOHC)-2, General Description.>	Go to step 3.
3	<b>CHECK REAR CATALYTIC CONVERTER.</b> Separate rear catalytic converter from rear exhaust pipe.	Is there damage at rear face of rear catalyst?	Replace front catalytic converter <Ref. to EC(SOHC)-3, Front Catalytic Converter.> and rear catalytic converter <Ref. to EC(SOHC)-6, Rear Catalytic Converter.>.	Go to step 4.
4	<b>CHECK FRONT CATALYTIC CONVERTER.</b> Remove front catalytic converter.	Is there damage at rear face or front face of front catalyst?	Replace front catalytic converter. <Ref. to EC(SOHC)-3, Front Catalytic Converter.>	Contact your Subaru distributor. NOTE: Inspection by DTM is required, because probable cause is deterioration of multiple parts.

# DIAGNOSTIC PROCEDURE WITH DIAGNOSTIC TROUBLE CODE (DTC)

Engine (Diagnostics)

## AK: DTC P0444 — EVAPORATIVE EMISSION CONTROL SYSTEM PURGE CONTROL VALVE CIRCUIT LOW INPUT — S058521G47

- **DTC DETECTING CONDITION:**
  - Two consecutive driving cycles with fault
- **TROUBLE SYMPTOM:**
  - Erroneous idling

**CAUTION:**

After repair or replacement of faulty parts, conduct Clear Memory Mode <Ref. to EN(SOHC)-45, OPERATION, Clear Memory Mode.> and Inspection Mode <Ref. to EN(SOHC)-42, OPERATION, Inspection Mode.>.

● **WIRING DIAGRAM:**

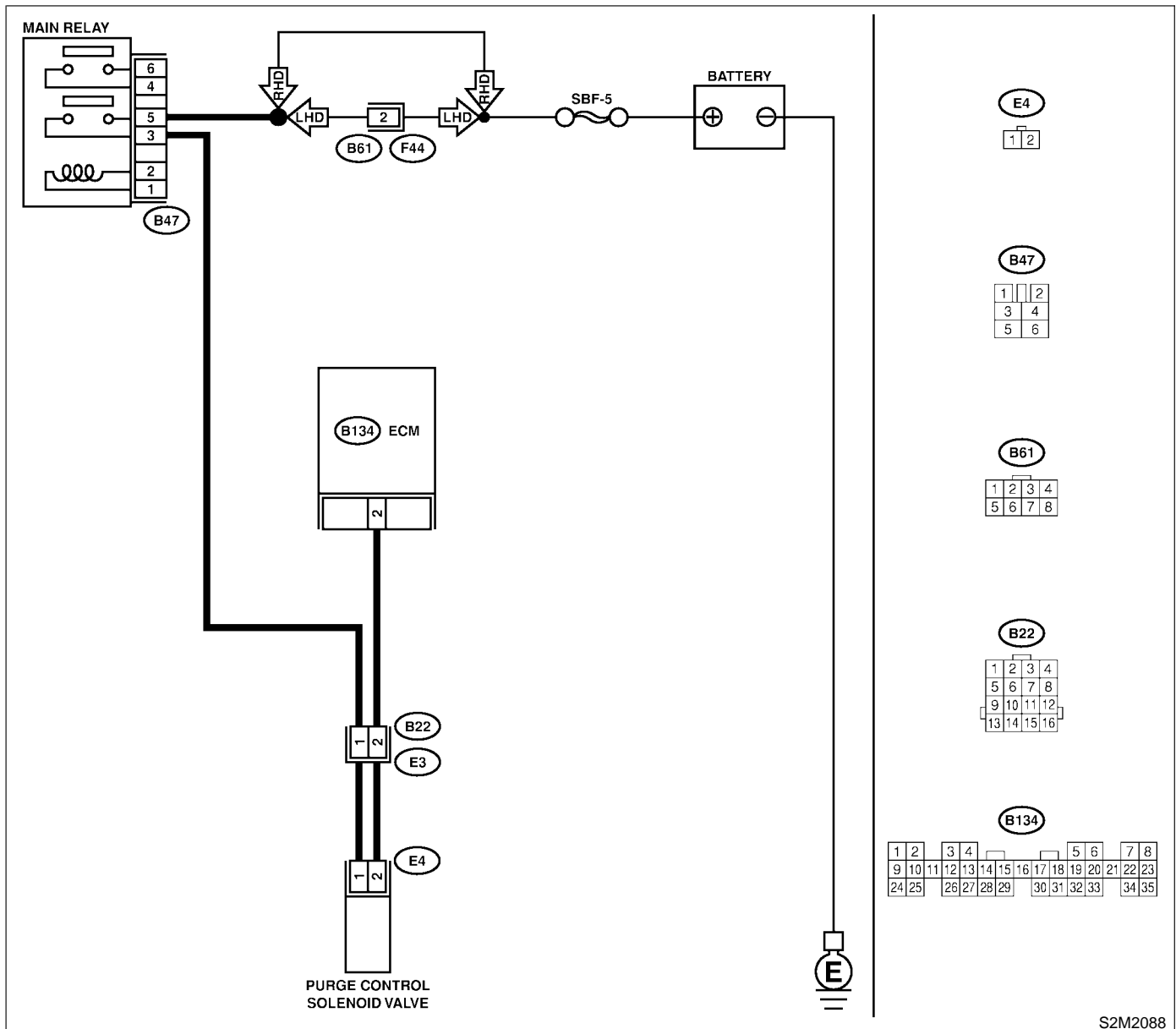

S2M2088

# DIAGNOSTIC PROCEDURE WITH DIAGNOSTIC TROUBLE CODE (DTC)

Engine (Diagnostics)

No.	Step	Check	Yes	No
1	<p><b>CHECK OUTPUT SIGNAL FROM ECM.</b>                      1) Turn ignition switch to ON.                      2) Measure voltage between ECM and chassis ground.  <b>Connector &amp; terminal</b>                      (B134) No. 2 (+) — Chassis ground (-):</p>	Is the voltage more than 10 V?	Even if MIL lights up, the circuit has returned to a normal condition at this time. Contact with your Subaru distributor. NOTE: Inspection by DTM is required, because probable cause is deterioration of multiple parts.	Go to step 2.
2	<p><b>CHECK HARNESS BETWEEN PURGE CONTROL SOLENOID VALVE AND ECM CONNECTOR.</b>                      1) Turn ignition switch to OFF.                      2) Disconnect connectors from purge control solenoid valve and ECM.                      3) Measure resistance of harness between purge control solenoid valve connector and engine ground.  <b>Connector &amp; terminal</b>                      (E4) No. 2 — Engine ground:</p>	Is the resistance less than 10 $\Omega$ ?	Repair ground short circuit in harness between ECM and purge control solenoid valve connector.	Go to step 3.
3	<p><b>CHECK HARNESS BETWEEN PURGE CONTROL SOLENOID VALVE AND ECM CONNECTOR.</b>                      Measure resistance of harness between ECM and purge control solenoid valve of harness connector.  <b>Connector &amp; terminal</b>                      (B134) No. 2 — (E4) No. 2:</p>	Is the resistance less than 1 $\Omega$ ?	Go to step 4.	Repair open circuit in harness between ECM and purge control solenoid valve connector. NOTE: In this case, repair the following: <ul style="list-style-type: none"> <li>● Open circuit in harness between ECM and purge control solenoid valve connector</li> <li>● Poor contact in coupling connector (B22)</li> </ul>
4	<p><b>CHECK PURGE CONTROL SOLENOID VALVE.</b>                      1) Remove purge control solenoid valve.                      2) Measure resistance between purge control solenoid valve terminals.  <b>Terminals</b>                      No. 1 — No. 2:</p>	Is the resistance between 10 and 100 $\Omega$ ?	Go to step 5.	Replace purge control solenoid valve. <Ref. to EC(SOHC)-8, Purge Control Solenoid Valve.>
5	<p><b>CHECK POWER SUPPLY TO PURGE CONTROL SOLENOID VALVE.</b>                      1) Turn ignition switch to ON.                      2) Measure voltage between purge control solenoid valve and engine ground.  <b>Connector &amp; terminal</b>                      (E4) No. 1 (+) — Engine ground (-):</p>	Is the voltage more than 10 V?	Go to step 6.	Repair open circuit in harness between main relay and purge control solenoid valve connector.

# DIAGNOSTIC PROCEDURE WITH DIAGNOSTIC TROUBLE CODE (DTC)

Engine (Diagnostics)

No.	Step	Check	Yes	No
6	<b>CHECK POOR CONTACT.</b> Check poor contact in purge control solenoid valve connector.	Is there poor contact in purge control solenoid valve connector?	Repair poor contact in purge control solenoid valve connector.	Contact your Subaru distributor. NOTE: Inspection by DTM is required, because probable cause is deterioration of multiple parts.



**MEMO:**

# DIAGNOSTIC PROCEDURE WITH DIAGNOSTIC TROUBLE CODE (DTC)

Engine (Diagnostics)

## AL: DTC P0445 — EVAPORATIVE EMISSION CONTROL SYSTEM PURGE CONTROL VALVE CIRCUIT HIGH INPUT —

S058521G48

- **DTC DETECTING CONDITION:**
  - Two consecutive driving cycles with fault
- **TROUBLE SYMPTOM:**
  - Erroneous idling

### CAUTION:

After repair or replacement of faulty parts, conduct Clear Memory Mode <Ref. to EN(SOHC)-45, OPERATION, Clear Memory Mode.> and Inspection Mode <Ref. to EN(SOHC)-42, OPERATION, Inspection Mode.>.

### ● WIRING DIAGRAM:

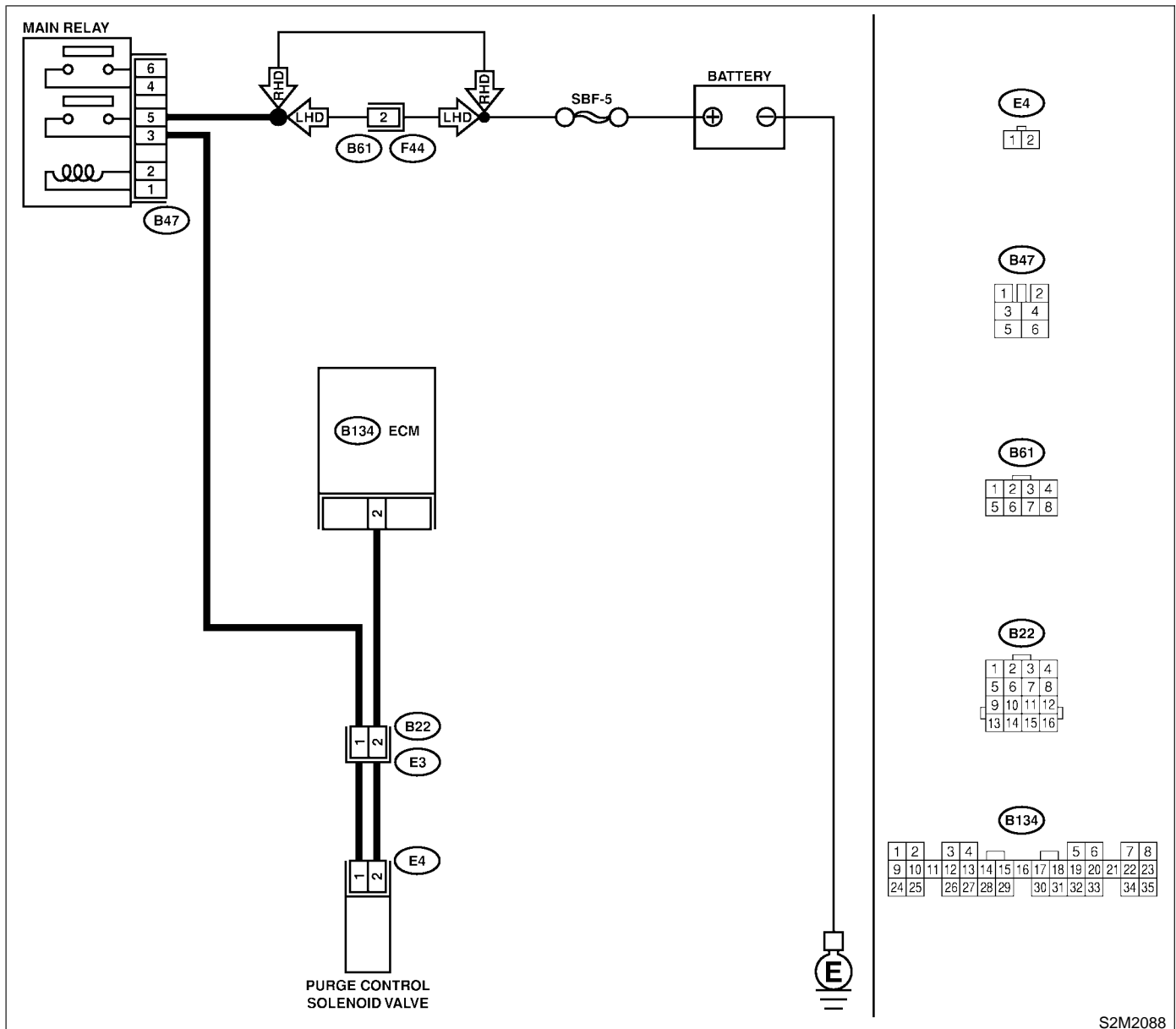

S2M2088

# DIAGNOSTIC PROCEDURE WITH DIAGNOSTIC TROUBLE CODE (DTC)

Engine (Diagnostics)

No.	Step	Check	Yes	No
1	<p><b>CHECK OUTPUT SIGNAL FROM ECM.</b>                      1) Turn ignition switch to OFF.                      2) Connect test mode connector at the lower portion of instrument panel (on the driver's side), to the side of the center console box.                      3) Turn ignition switch to ON.                      4) While operating purge control solenoid valve, measure voltage between ECM and chassis ground.                      NOTE:                      Purge control solenoid valve operation can be executed using Subaru Select Monitor. For procedure, refer to "Compulsory Valve Operation Check Mode". &lt;Ref. to EN(SOHC)-46, Compulsory Valve Operation Check Mode.&gt;  <b>Connector &amp; terminal</b>  <b>(B134) No. 2 (+) — Chassis ground (-):</b></p>	Does voltage change between 0 and 10 V?	Go to step 2.	Even if MIL light up, the circuit has returned to a normal condition at this time. In this case, repair poor contact in ECM connector.
2	<p><b>CHECK OUTPUT SIGNAL FROM ECM.</b>                      1) Turn ignition switch to ON.                      2) Measure voltage between ECM and chassis ground.  <b>Connector &amp; terminal</b>  <b>(B134) No. 2 (+) — Chassis ground (-):</b></p>	Is the voltage more than 10 V?	Go to step 4.	Go to step 3.
3	<p><b>CHECK POOR CONTACT.</b>                      Check poor contact in ECM connector.</p>	Is there poor contact in ECM connector?	Repair poor contact in ECM connector.	Replace ECM. <Ref. to FU(SOHC)-49, Engine Control Module.>
4	<p><b>CHECK HARNESS BETWEEN PURGE CONTROL SOLENOID VALVE AND ECM CONNECTOR.</b>                      1) Turn ignition switch to OFF.                      2) Disconnect connector from purge control solenoid valve.                      3) Turn ignition switch to ON.                      4) Measure voltage between ECM and chassis ground.  <b>Connector &amp; terminal</b>  <b>(B134) No. 2 (+) — Chassis ground (-):</b></p>	Is the voltage more than 10 V?	Repair battery short circuit in harness between ECM and purge control solenoid valve connector. After repair, replace ECM. <Ref. to FU(SOHC)-49, Engine Control Module.>	Go to step 5.
5	<p><b>CHECK PURGE CONTROL SOLENOID VALVE.</b>                      1) Turn ignition switch to OFF.                      2) Measure resistance between purge control solenoid valve terminals.  <b>Terminals</b>  <b>No. 1 — No. 2:</b></p>	Is the resistance less than 1 $\Omega$ ?	Replace purge control solenoid valve <Ref. to EC(SOHC)-8, Purge Control Solenoid Valve.> and ECM <Ref. to FU(SOHC)-49, Engine Control Module.>	Go to step 6.
6	<p><b>CHECK POOR CONTACT.</b>                      Check poor contact in ECM connector.</p>	Is there poor contact in ECM connector?	Repair poor contact in ECM connector.	Replace ECM. <Ref. to FU(SOHC)-49, Engine Control Module.>

# DIAGNOSTIC PROCEDURE WITH DIAGNOSTIC TROUBLE CODE (DTC)

Engine (Diagnostics)

## AM: DTC P0461 — FUEL LEVEL SENSOR CIRCUIT RANGE/PERFORMANCE PROBLEM —

S058521B54

### ● DTC DETECTING CONDITION:

- Two consecutive driving cycles with fault

### CAUTION:

After repair or replacement of faulty parts, conduct Clear Memory Mode <Ref. to EN(SOHC)-45, OPERATION, Clear Memory Mode.> and Inspection Mode <Ref. to EN(SOHC)-42, OPERATION, Inspection Mode.>.

### ● WIRING DIAGRAM:

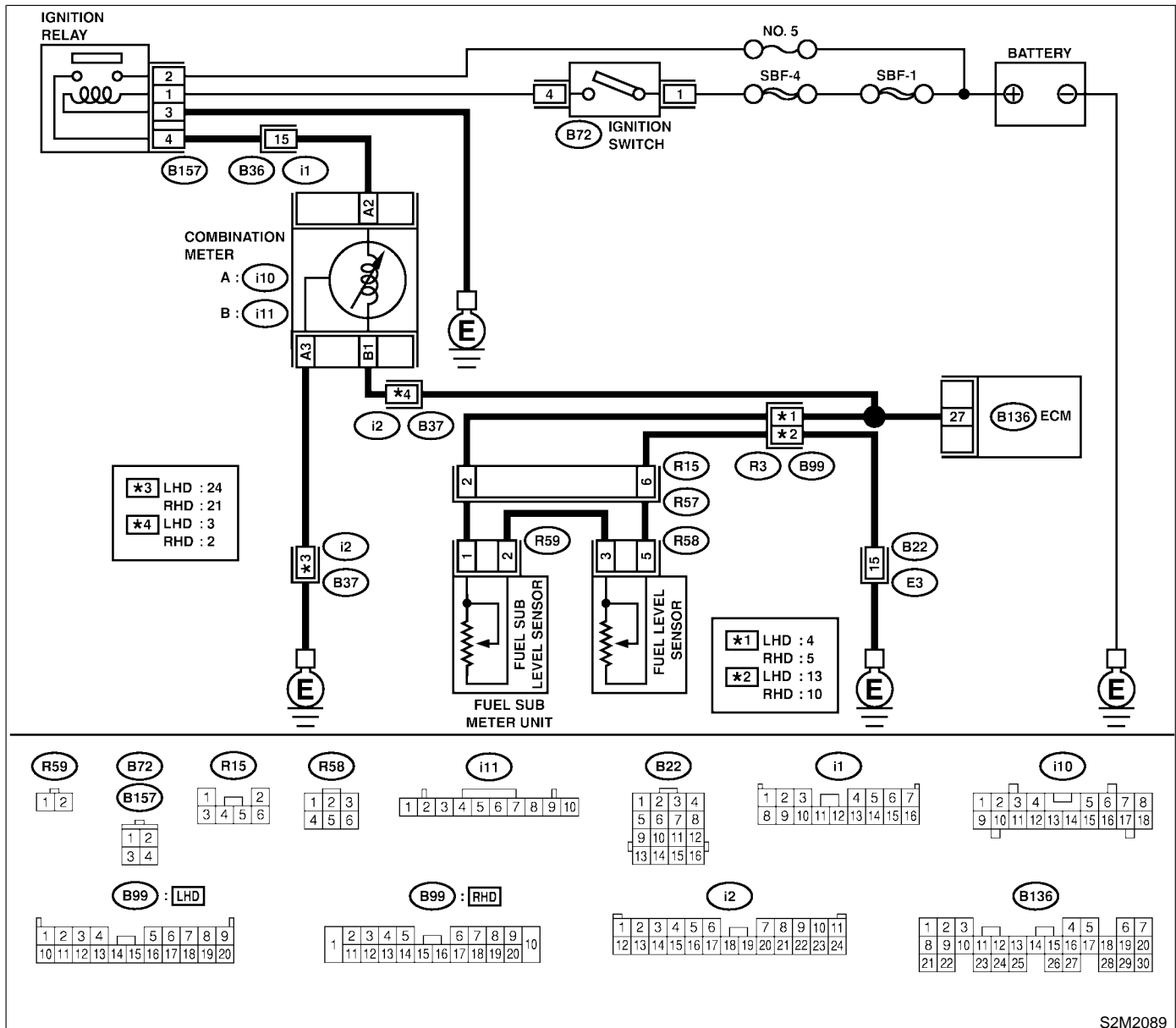

S2M2089

# DIAGNOSTIC PROCEDURE WITH DIAGNOSTIC TROUBLE CODE (DTC)

Engine (Diagnostics)

No.	Step	Check	Yes	No
1	CHECK ANY OTHER DTC ON DISPLAY.	Does the Subaru Select Monitor or OBD-II general scan tool indicate DTC P0462 or P0463?	Inspect DTC P0462 or P0463 using "17. List of Diagnostic Trouble Code (DTC)". <Ref. to EN(SOHC)-80, List of Diagnostic Trouble Code (DTC).> NOTE: In this case, it is not necessary to inspect this trouble.	Replace fuel level sensor <Ref. to FU(SOHC)-64, Fuel Level Sensor.> and fuel sub level sensor <Ref. to FU(SOHC)-65, Fuel Sub Level Sensor.>.

# DIAGNOSTIC PROCEDURE WITH DIAGNOSTIC TROUBLE CODE (DTC)

Engine (Diagnostics)

## AN: DTC P0462 — FUEL LEVEL SENSOR CIRCUIT LOW INPUT —

S058521B55

### • DTC DETECTING CONDITION:

- Two consecutive driving cycles with fault

### CAUTION:

After repair or replacement of faulty parts, conduct Clear Memory Mode <Ref. to EN(SOHC)-45, OPERATION, Clear Memory Mode.> and Inspection Mode <Ref. to EN(SOHC)-42, OPERATION, Inspection Mode.>.

### • WIRING DIAGRAM:

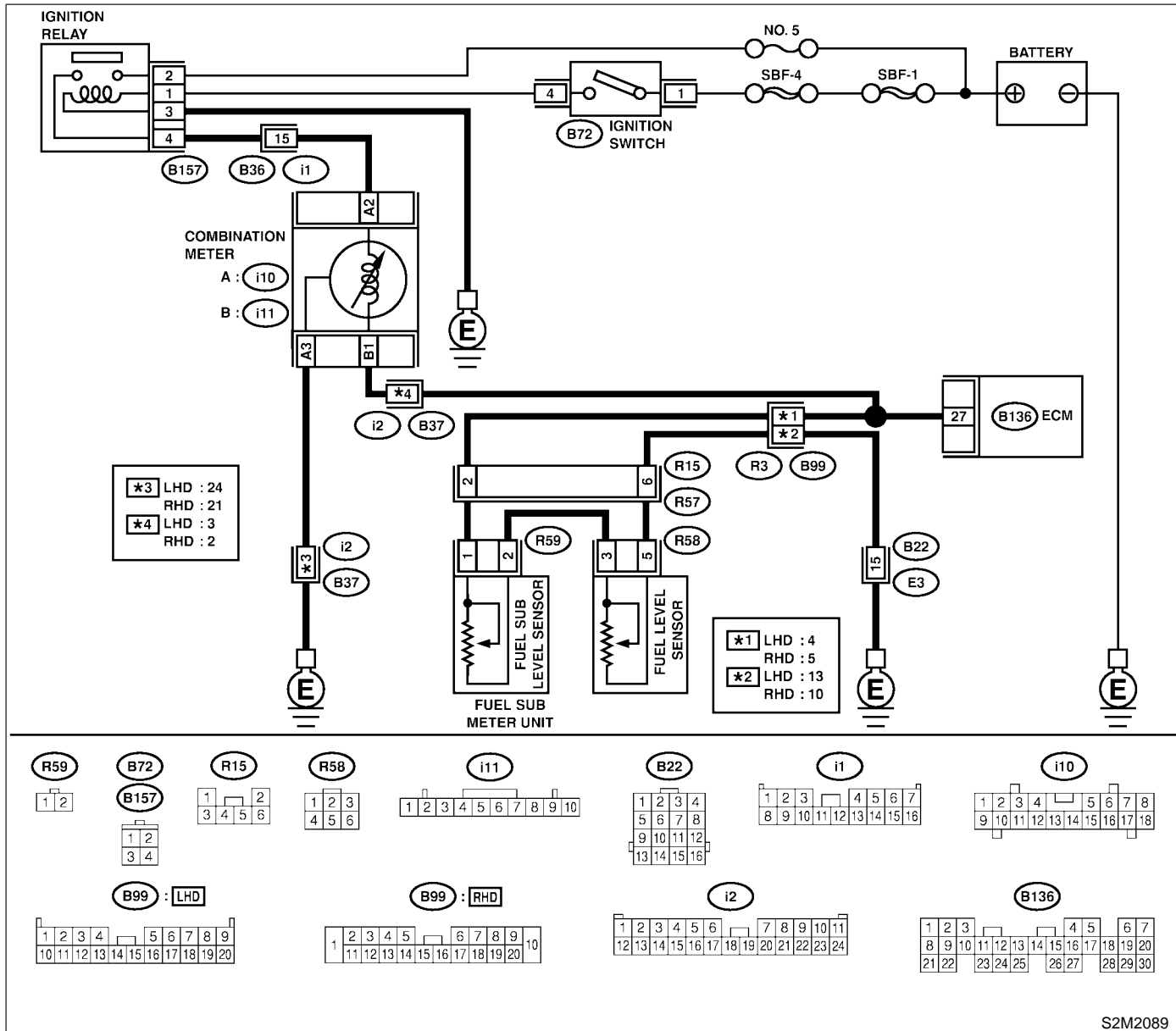

S2M2089

No.	Step	Check	Yes	No
1	CHECK SPEEDOMETER AND TACHOMETER OPERATION IN COMBINATION METER.	Does speedometer and tachometer operate normally?	Go to step 2.	Repair or replace combination meter. <Ref. to IDI-4, Combination Meter System.>

# DIAGNOSTIC PROCEDURE WITH DIAGNOSTIC TROUBLE CODE (DTC)

Engine (Diagnostics)

No.	Step	Check	Yes	No
2	<p><b>CHECK INPUT SIGNAL FOR ECM.</b>                      1) Turn ignition switch to ON. (Engine OFF)                      2) Measure voltage between ECM connector and chassis ground.</p> <p><b>Connector &amp; terminal</b>  <b>(B136) No. 27 (+) — Chassis ground (-):</b></p>	Is the voltage less than 0.12 V?	Go to step 6.	Go to step 3.
3	<p><b>CHECK INPUT SIGNAL FOR ECM. (USING SUBARU SELECT MONITOR.)</b>                      Read data of fuel level sensor signal using Subaru Select Monitor.                      NOTE:                      ● Subaru Select Monitor                      For detailed operation procedure, refer to the "READ CURRENT DATA FOR ENGINE".                      &lt;Ref. to EN(SOHC)-34, Subaru Select Monitor.&gt;</p>	Does the value change less than 0.12 V by shaking harness and connector of ECM while monitoring the value with Subaru Select Monitor?	Repair poor contact in ECM connector.	Even if MIL lights up, the circuit has returned to a normal condition at this time. A temporary poor contact of the connector may be the cause. NOTE: In this case, repair the following: ● Poor contact in combination meter connector ● Poor contact in ECM connector
4	<p><b>CHECK INPUT VOLTAGE OF ECM.</b>                      1) Turn ignition switch to OFF.                      2) Separate fuel tank cord connector (R57) and rear wiring harness connector (R15).                      3) Turn ignition switch to ON.                      4) Measure voltage of harness between ECM connector and chassis ground.</p> <p><b>Connector &amp; terminal</b>  <b>(B136) No. 27 (+) — Chassis ground (-):</b></p>	Is the voltage more than 0.12 V?	Go to step 4.	Go to step 7.
5	<p><b>CHECK HARNESS BETWEEN ECM AND COMBINATION METER.</b>                      1) Turn ignition switch to OFF.                      2) Disconnect connector from connector (i11) and ECM connector.                      3) Measure resistance between ECM and chassis ground.</p> <p><b>Connector &amp; terminal</b>  <b>(B136) No. 27 — Chassis ground:</b></p>	Is the resistance more than 1 MΩ?	Go to step 6.	Repair ground short circuit in harness between ECM and combination meter connector.
6	<p><b>CHECK HARNESS BETWEEN ECM AND COMBINATION METER.</b>                      Measure resistance between ECM and combination meter connector.</p> <p><b>Connector &amp; terminal</b>  <b>(B136) No. 27 — (i11) No. 1:</b></p>	Is the resistance less than 10 Ω?	Repair or replace combination meter. <Ref. to IDI-4, Combination Meter System.>	Repair open circuit between ECM and combination meter connector. NOTE: In this case, repair the following: Poor contact in coupling connector (i2)

# DIAGNOSTIC PROCEDURE WITH DIAGNOSTIC TROUBLE CODE (DTC)

Engine (Diagnostics)

No.	Step	Check	Yes	No
7	<b>CHECK FUEL TANK CORD.</b> 1) Turn ignition switch to OFF. 2) Disconnect connector from fuel sub level sensor. 3) Measure resistance between fuel sub level sensor and chassis ground. <b>Connector &amp; terminal</b> <b>(R59) No. 1 — Chassis ground:</b>	Is the resistance more than 1 M $\Omega$ ?	Go to step 8.	Repair ground short circuit in fuel tank cord.
8	<b>CHECK FUEL TANK CORD.</b> 1) Disconnect connector from fuel pump assembly. 2) Measure resistance between fuel pump assembly and chassis ground. <b>Connector &amp; terminal</b> <b>(R59) No. 2 — Chassis ground:</b>	Is the resistance more than 1 M $\Omega$ ?	Go to step 9.	Repair ground short circuit in fuel tank cord.
9	<b>CHECK FUEL LEVEL SENSOR.</b> <b>WARNING:</b> <b>During work procedures, if fuel tank is more than 3/4 full, be careful because fuel may spill.</b> 1) Remove fuel pump assembly. <Ref. to FU(SOHC)-62 Fuel Pump.> 2) Measure resistance between fuel level sensor and terminals with its float set to the full position. <b>Terminals</b> <b>No. 3 — No. 5:</b>	Is the resistance between 0.5 and 2.5 $\Omega$ ?	Go to step 10.	Replace fuel level sensor.
10	<b>CHECK FUEL SUB LEVEL SENSOR.</b> <b>WARNING:</b> <b>During work procedures, if fuel tank is more than 3/4 full, be careful because fuel may spill.</b> 1) Remove fuel sub level sensor. <Ref. to FU(SOHC)-65, Fuel Sub Level Sensor.> 2) Measure resistance between fuel sub level sensor and terminals with its float set to the full position. <b>Terminals</b> <b>No. 1 — No. 2:</b>	Is the resistance between 0.5 and 2.5 $\Omega$ ?	Repair poor contact in harness between ECM and combination meter connector.	Replace fuel sub level sensor.



**MEMO:**

# DIAGNOSTIC PROCEDURE WITH DIAGNOSTIC TROUBLE CODE (DTC)

Engine (Diagnostics)

## AO: DTC P0463 — FUEL LEVEL SENSOR CIRCUIT HIGH INPUT — S058521B56

- **DTC DETECTING CONDITION:**
  - Two consecutive driving cycles with fault

### CAUTION:

After repair or replacement of faulty parts, conduct Clear Memory Mode <Ref. to EN(SOHC)-45, OPERATION, Clear Memory Mode.> and Inspection Mode <Ref. to EN(SOHC)-42, OPERATION, Inspection Mode.>.

### ● WIRING DIAGRAM:

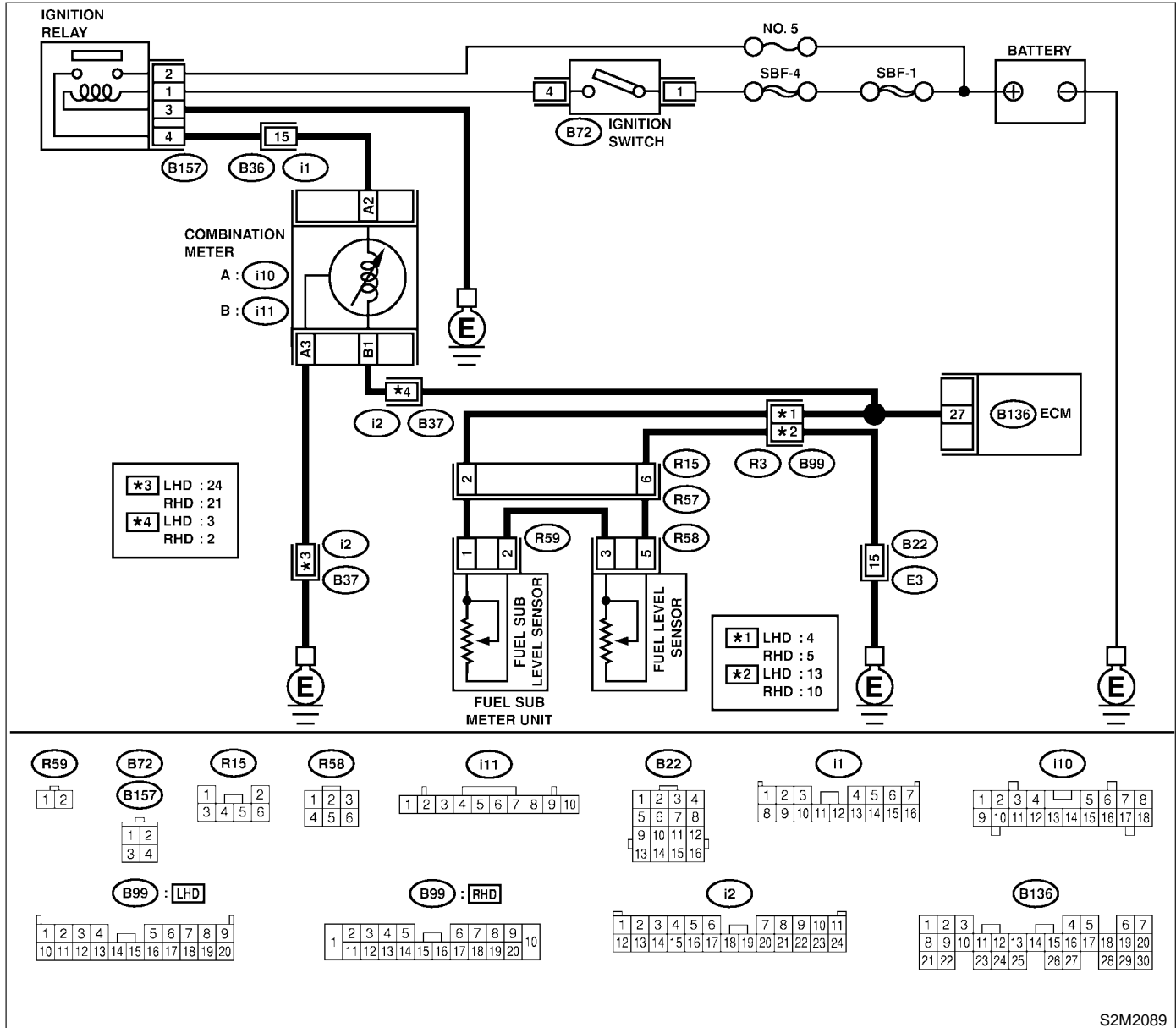

S2M2089

No.	Step	Check	Yes	No
1	CHECK SPEEDOMETER AND TACHOMETER OPERATION IN COMBINATION METER.	Does speedometer and tachometer operate normally?	Go to step 2.	Repair or replace combination meter. <Ref. to IDI-4, Combination Meter System.>

# DIAGNOSTIC PROCEDURE WITH DIAGNOSTIC TROUBLE CODE (DTC)

Engine (Diagnostics)

No.	Step	Check	Yes	No
2	<p><b>CHECK INPUT SIGNAL FOR ECM.</b>                      1) Turn ignition switch to ON. (Engine OFF)                      2) Measure voltage between ECM connector and chassis ground.  <b>Connector &amp; terminal</b>  <b>(B136) No. 27 (+) — Chassis ground (-):</b></p>	Is the voltage more than 4.75 V?	Go to step 3.	Even if MIL lights up, the circuit has returned to a normal condition at this time. A temporary poor contact of the connector may be the cause. NOTE: In this case, repair the following: <ul style="list-style-type: none"> <li>● Poor contact in fuel pump connector</li> <li>● Poor contact in coupling connector (B22, B37 and R57)</li> </ul>
3	<p><b>CHECK INPUT VOLTAGE OF ECM.</b>                      1) Turn ignition switch to OFF.                      2) Disconnect combination meter connector (i11) and ECM connector.                      3) Turn ignition switch to ON.                      4) Measure voltage of harness between ECM and chassis ground.  <b>Connector &amp; terminal</b>  <b>(B136) No. 27 (+) — Chassis ground (-):</b></p>	Is the voltage more than 4.75 V?	Go to step 4.	Repair battery short circuit between ECM and combination meter connector.
4	<p><b>CHECK HARNESS BETWEEN ECM AND FUEL TANK CORD.</b>                      1) Turn ignition switch to OFF.                      2) Separate fuel tank cord connector (R57) and rear wiring harness connector (R15).                      3) Measure resistance between ECM and fuel tank cord.  <b>Connector &amp; terminal</b>  <b>(B136) No. 27 — (R15) No. 2:</b></p>	Is the resistance less than 5 Ω?	Go to step 5.	Repair open circuit between ECM and fuel tank cord.
5	<p><b>CHECK HARNESS BETWEEN FUEL TANK CORD AND CHASSIS GROUND.</b>                      Measure resistance between fuel tank cord and chassis ground.  <b>Connector &amp; terminal</b>  <b>(R15) No. 6 — Chassis ground:</b></p>	Is the resistance less than 5 Ω?	Go to step 6.	Repair open circuit between fuel tank cord and chassis ground. NOTE: In this case, repair the following: Poor contact in coupling connectors (B22 and B99)
6	<p><b>CHECK FUEL TANK CORD.</b>                      1) Disconnect connector from fuel level sensor.                      2) Measure resistance between fuel level sensor and coupling connector.  <b>Connector &amp; terminal</b>  <b>(R57) No. 6 — (R58) No. 5:</b></p>	Is the resistance less than 10 Ω?	Go to step 7.	Repair open circuit between coupling connector and fuel level sensor.

# DIAGNOSTIC PROCEDURE WITH DIAGNOSTIC TROUBLE CODE (DTC)

Engine (Diagnostics)

No.	Step	Check	Yes	No
7	<b>CHECK FUEL TANK CORD.</b> 1) Disconnect connector from fuel sub level sensor. 2) Measure resistance between fuel level sensor and fuel sub level sensor. <b>Connector &amp; terminal</b> <b>(R58) No. 3 — (R59) No. 2:</b>	Is the resistance less than 10 Ω?	Go to step 8.	Repair open circuit between fuel level sensor and fuel sub level sensor.
8	<b>CHECK FUEL TANK CORD.</b> Measure resistance between fuel sub level sensor and coupling connector. <b>Connector &amp; terminal</b> <b>(R57) No. 2 — (R59) No. 1:</b>	Is the resistance less than 10 Ω?	Go to step 9.	Repair open circuit between coupling connector and fuel sub level sensor.
9	<b>CHECK FUEL LEVEL SENSOR.</b> <b>WARNING:</b> <b>During work procedures, if fuel tank is more than 3/4 full, be careful because fuel may spill.</b> 1) Remove fuel pump assembly. <Ref. to FU(SOHC)-62, Fuel Pump.> 2) While moving fuel level sensor float up and down, measure resistance between fuel level sensor terminals. <b>Terminals</b> <b>No. 3 — No. 5:</b>	Is the resistance more than 54.5 Ω?	Replace fuel level sensor. <Ref. to FU(SOHC)-64, Fuel Level Sensor.>	Go to step 10.
10	<b>CHECK FUEL SUB LEVEL SENSOR.</b> <b>WARNING:</b> <b>During work procedures, if fuel tank is more than 3/4 full, be careful because fuel may spill.</b> 1) Remove fuel sub level sensor. <Ref. to FU(SOHC)-65, Fuel Sub Level Sensor.> 2) While moving fuel sub level sensor float up and down, measure resistance between fuel sub level sensor terminals. <b>Terminals</b> <b>No. 1 — No. 2:</b>	Is the resistance more than 41.5 Ω?	Replace fuel sub level sensor. <Ref. to FU(SOHC)-65, Fuel Sub Level Sensor.>	Replace combination meter. <Ref. to IDI-15, Combination Meter Assembly.>

**MEMO:**

# DIAGNOSTIC PROCEDURE WITH DIAGNOSTIC TROUBLE CODE (DTC)

Engine (Diagnostics)

## AP: DTC P0464 — FUEL LEVEL SENSOR INTERMITTENT INPUT— S058521G01

- **DTC DETECTING CONDITION:**
  - Two consecutive driving cycles with fault

**CAUTION:**

After repair or replacement of faulty parts, conduct Clear Memory Mode <Ref. to EN(SOHC)-45, OPERATION, Clear Memory Mode.> and Inspection Mode <Ref. to EN(SOHC)-42, OPERATION, Inspection Mode.>.

● **WIRING DIAGRAM:**

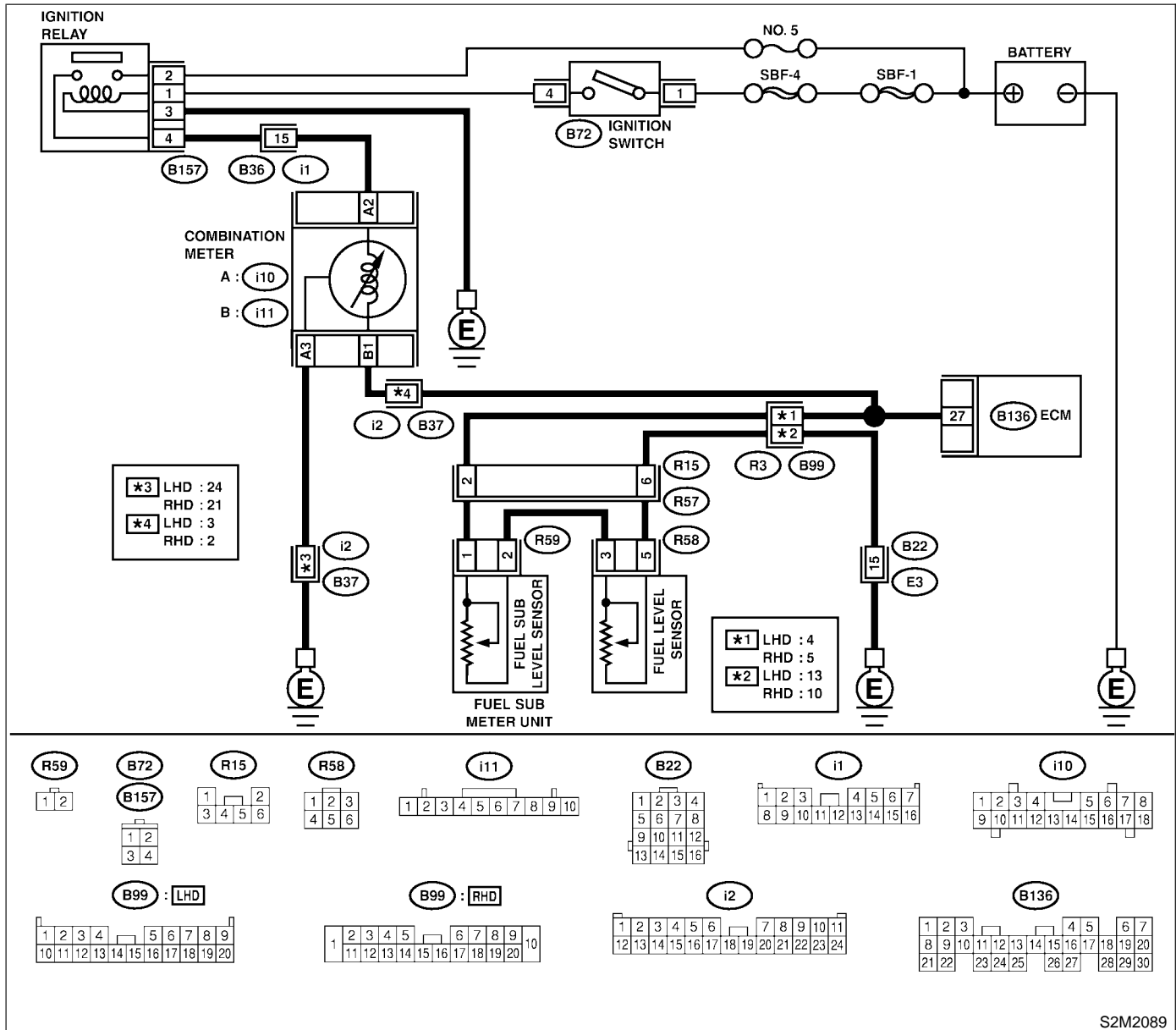

S2M2089

# DIAGNOSTIC PROCEDURE WITH DIAGNOSTIC TROUBLE CODE (DTC)

Engine (Diagnostics)

No.	Step	Check	Yes	No
1	<b>CHECK ANY OTHER DTC ON DISPLAY.</b>	Does the Subaru Select Monitor or OBD-II general scan tool indicate DTC P0462 or P0463?	Inspect DTC P0462 or P0463 using "17. List of Diagnostic Trouble Code (DTC)". <Ref. to EN(SOHC)-80, List of Diagnostic Trouble Code (DTC).>	Go to step 2.
2	<b>CHECK FUEL LEVEL SENSOR.</b> <b>WARNING:</b> <b>During work procedures, if fuel tank is more than 3/4 full, be careful because fuel may spill.</b> 1) Remove fuel pump assembly. <Ref. to FU(SOHC)-62, Fuel Pump.> 2) While moving fuel level sensor float up and down, make sure that the resistance between fuel level sensor terminals changes smoothly. <b>Terminals</b> <b>No. 3 — No. 5:</b>	Does the resistance change smoothly?	Go to step 3.	Replace fuel level sensor. <Ref. to FU(SOHC)-64, Fuel Level Sensor.>
3	<b>CHECK FUEL SUB LEVEL SENSOR.</b> <b>WARNING:</b> <b>During work procedures, if fuel tank is more than 3/4 full, be careful because fuel may spill.</b> 1) Remove fuel sub level sensor. <Ref. to FU(SOHC)-65, Fuel Sub Level Sensor.> 2) While moving fuel sub level sensor float up and down, make sure that the resistance between fuel level sensor terminals changes smoothly. <b>Terminals</b> <b>No. 1 — No. 2:</b>	Does the resistance change smoothly?	Repair poor contact in ECM, combination meter and coupling connectors.	Replace fuel sub level sensor. <Ref. to FU(SOHC)-65, Fuel Sub Level Sensor.>

# DIAGNOSTIC PROCEDURE WITH DIAGNOSTIC TROUBLE CODE (DTC)

Engine (Diagnostics)

---

## AQ: DTC P0480 — COOLING FAN RELAY 1 CIRCUIT LOW INPUT — S058821B57

- **DTC DETECTING CONDITION:**
  - Two consecutive driving cycles with fault
- **TROUBLE SYMPTOM:**
  - Radiator fan does not operate properly.
  - Overheating

### CAUTION:

After repair or replacement of faulty parts, conduct Clear Memory Mode <Ref. to EN(SOHC)-45, OPERATION, Clear Memory Mode.> and Inspection Mode <Ref. to EN(SOHC)-42, OPERATION, Inspection Mode.>.



# DIAGNOSTIC PROCEDURE WITH DIAGNOSTIC TROUBLE CODE (DTC)

Engine (Diagnostics)

## ● WIRING DIAGRAM:

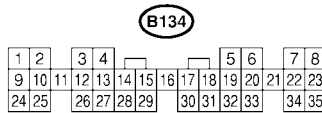
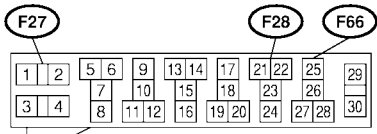
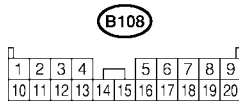
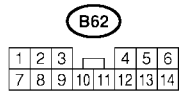
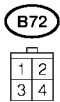
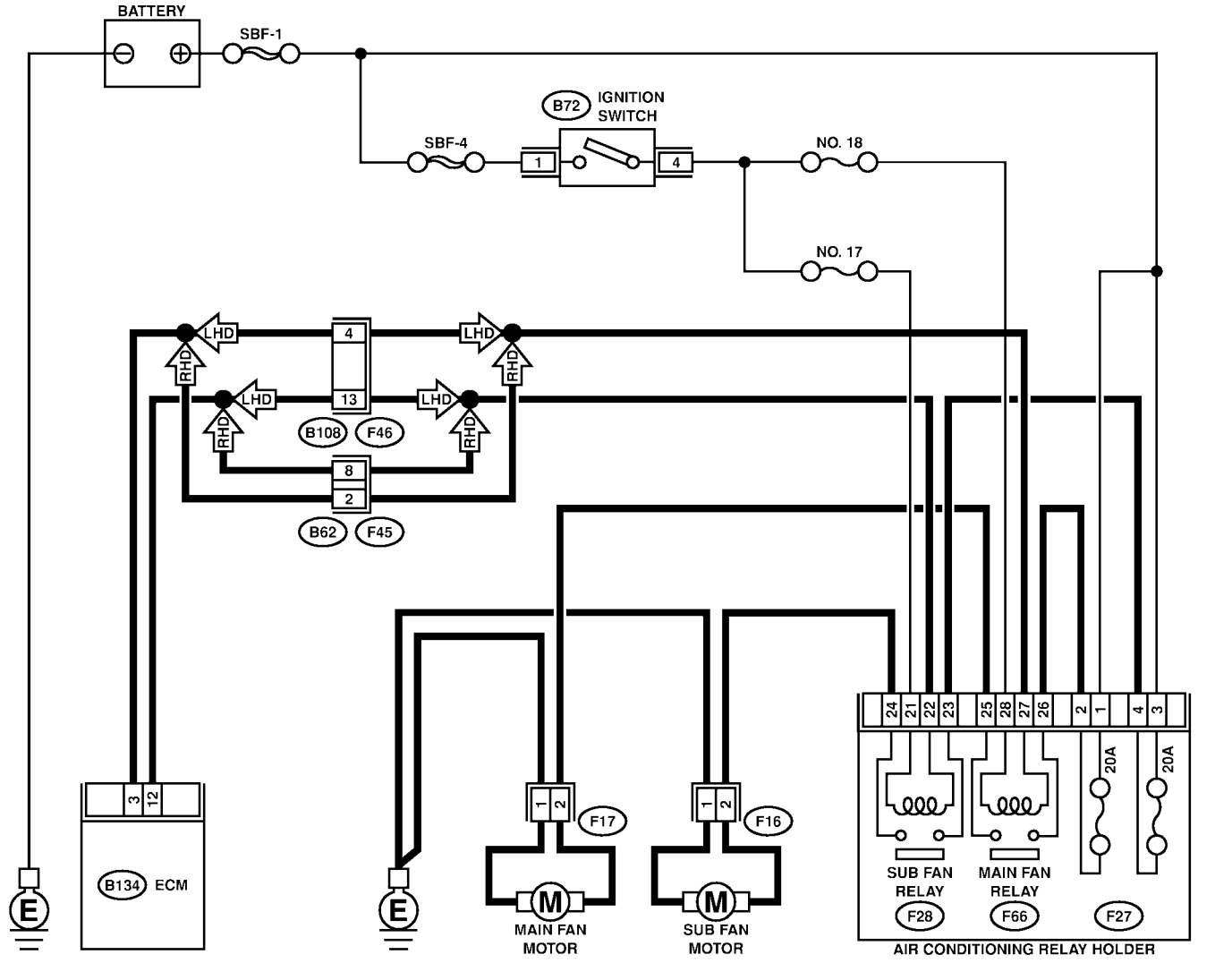

S2M2090

# DIAGNOSTIC PROCEDURE WITH DIAGNOSTIC TROUBLE CODE (DTC)

Engine (Diagnostics)

No.	Step	Check	Yes	No
1	<p><b>CHECK OUTPUT SIGNAL FROM ECM.</b>                      1) Turn ignition switch to OFF.                      2) Connect test mode connector at the lower portion of instrument panel (on the driver's side), to the side of the center console box.                      3) Turn ignition switch to ON.                      4) While operating radiator fan relay, measure voltage between ECM terminal and ground.                      NOTE:                      Radiator fan relay operation can be executed using Subaru Select Monitor. For procedure, refer to "Compulsory Valve Operation Check Mode". &lt;Ref. to EN(SOHC)-34, Subaru Select Monitor.&gt;</p> <p><b>Connector &amp; terminal</b>  <b>(B134) No. 3 (+) — Chassis ground (-):</b></p>	Does voltage change between 0 and 10 V?	Repair poor contact in ECM connector.	Go to step 2.
2	<p><b>CHECK GROUND SHORT CIRCUIT IN RADIATOR MAIN FAN RELAY CONTROL CIRCUIT.</b>                      1) Turn ignition switch to OFF.                      2) Disconnect connectors from ECM.                      3) Measure resistance of harness between ECM connector and chassis ground.  <b>Connector &amp; terminal</b>  <b>(B134) No. 3 — Chassis ground:</b></p>	Is the resistance less than 10 Ω?	Repair ground short circuit in radiator main fan relay control circuit.	Go to step 3.
3	<p><b>CHECK POWER SUPPLY FOR RELAY.</b>                      1) Remove main fan relay from A/C relay holder.                      2) Turn ignition switch to ON.                      3) Measure voltage between fuse and relay box (F/B) connector and chassis ground.  <b>Connector &amp; terminal</b>  <b>(F66) No. 28 (+) — Chassis ground (-):</b></p>	Is the voltage more than 10 V?	Go to step 4.	Repair open circuit in harness between ignition switch and fuse and relay box (F/B) connector.
4	<p><b>CHECK MAIN FAN RELAY.</b>                      1) Turn ignition switch to OFF.                      2) Measure resistance between main fan relay terminals.  <b>Terminal</b>  <b>No. 28 — No. 27:</b></p>	Is the resistance between 87 and 107 Ω?	Go to step 5.	Replace main fan relay.
5	<p><b>CHECK OPEN CIRCUIT IN MAIN FAN RELAY CONTROL CIRCUIT.</b>                      Measure resistance of harness between ECM and main fan relay connector.  <b>Connector &amp; terminal</b>  <b>(B134) No. 3 — (F66) No. 27:</b></p>	Is the resistance less than 1 Ω?	Go to step 6.	Repair harness and connector. NOTE: In this case, repair the following: <ul style="list-style-type: none"> <li>● Open circuit in harness between ECM and main fan relay connector</li> <li>● Poor contact in coupling connector (F45, F46)</li> </ul>
6	<p><b>CHECK POOR CONTACT.</b>                      Check poor contact in ECM or main fan relay connector.</p>	Is there poor contact in ECM or main fan relay connector?	Repair poor contact in ECM or main fan relay connector.	Contact your Subaru distributor.

**MEMO:**

# DIAGNOSTIC PROCEDURE WITH DIAGNOSTIC TROUBLE CODE (DTC)

Engine (Diagnostics)

---

## AR: DTC P0483 — COOLING FAN FUNCTION PROBLEM — S058521B58

- **DTC DETECTING CONDITION:**
  - Two consecutive driving cycles with fault
- **TROUBLE SYMPTOM:**
  - Occurrence of noise
  - Overheating

### CAUTION:

After repair or replacement of faulty parts, conduct Clear Memory Mode <Ref. to EN(SOHC)-45, OPERATION, Clear Memory Mode.> and Inspection Mode <Ref. to EN(SOHC)-42, OPERATION, Inspection Mode.>.

### NOTE:

If the vehicle, with the engine idling, is placed very close to a wall or another vehicle, preventing normal cooling function, the OBD system may detect malfunction.

# DIAGNOSTIC PROCEDURE WITH DIAGNOSTIC TROUBLE CODE (DTC)

Engine (Diagnostics)

## ● WIRING DIAGRAM:

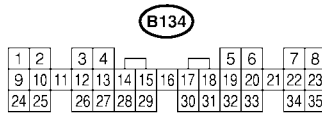
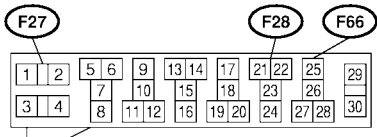
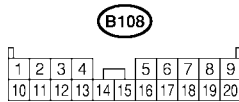
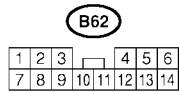
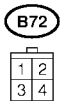
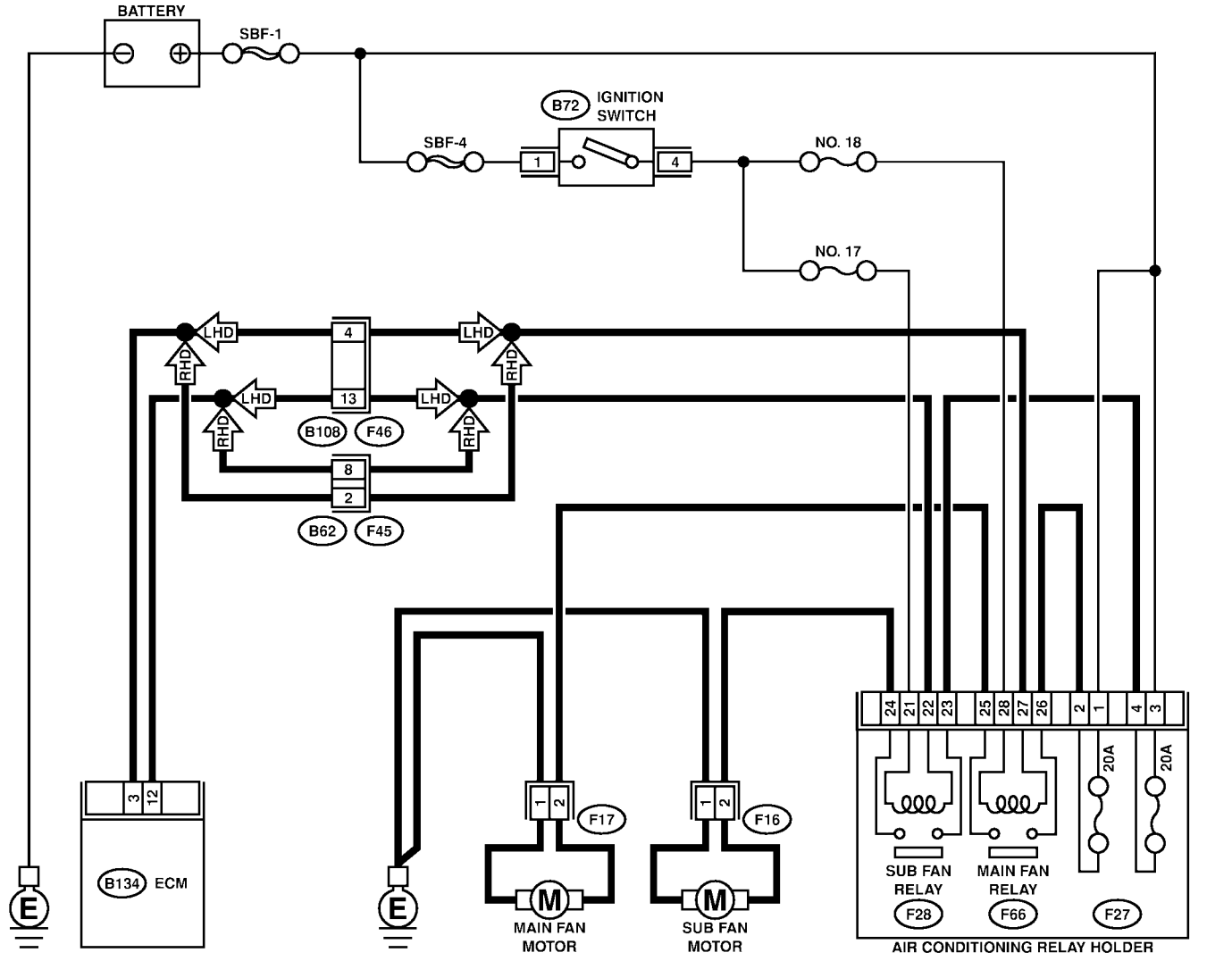

S2M2090

# DIAGNOSTIC PROCEDURE WITH DIAGNOSTIC TROUBLE CODE (DTC)

Engine (Diagnostics)

No.	Step	Check	Yes	No
1	CHECK ANY OTHER DTC ON DISPLAY.	Is there any other DTC on display?	Inspect the relevant DTC using "17. List of Diagnostic Trouble Code (DTC)". <Ref. to EN(SOHC)-80, List of Diagnostic Trouble Code (DTC).>	Check radiator fan and fan motor. <Ref. to CO-8, Radiator Main Fan System.> and <Ref. to CO-11, Radiator Sub Fan System.>

**MEMO:**

# DIAGNOSTIC PROCEDURE WITH DIAGNOSTIC TROUBLE CODE (DTC)

Engine (Diagnostics)

## AS: DTC P0500 — VEHICLE SPEED SENSOR MALFUNCTION — S058521B59

- **DTC DETECTING CONDITION:**
  - Immediately at fault recognition

**CAUTION:**

After repair or replacement of faulty parts, conduct Clear Memory Mode <Ref. to EN(SOHC)-45, OPERATION, Clear Memory Mode.> and Inspection Mode <Ref. to EN(SOHC)-42, OPERATION, Inspection Mode.>.

● **WIRING DIAGRAM:**

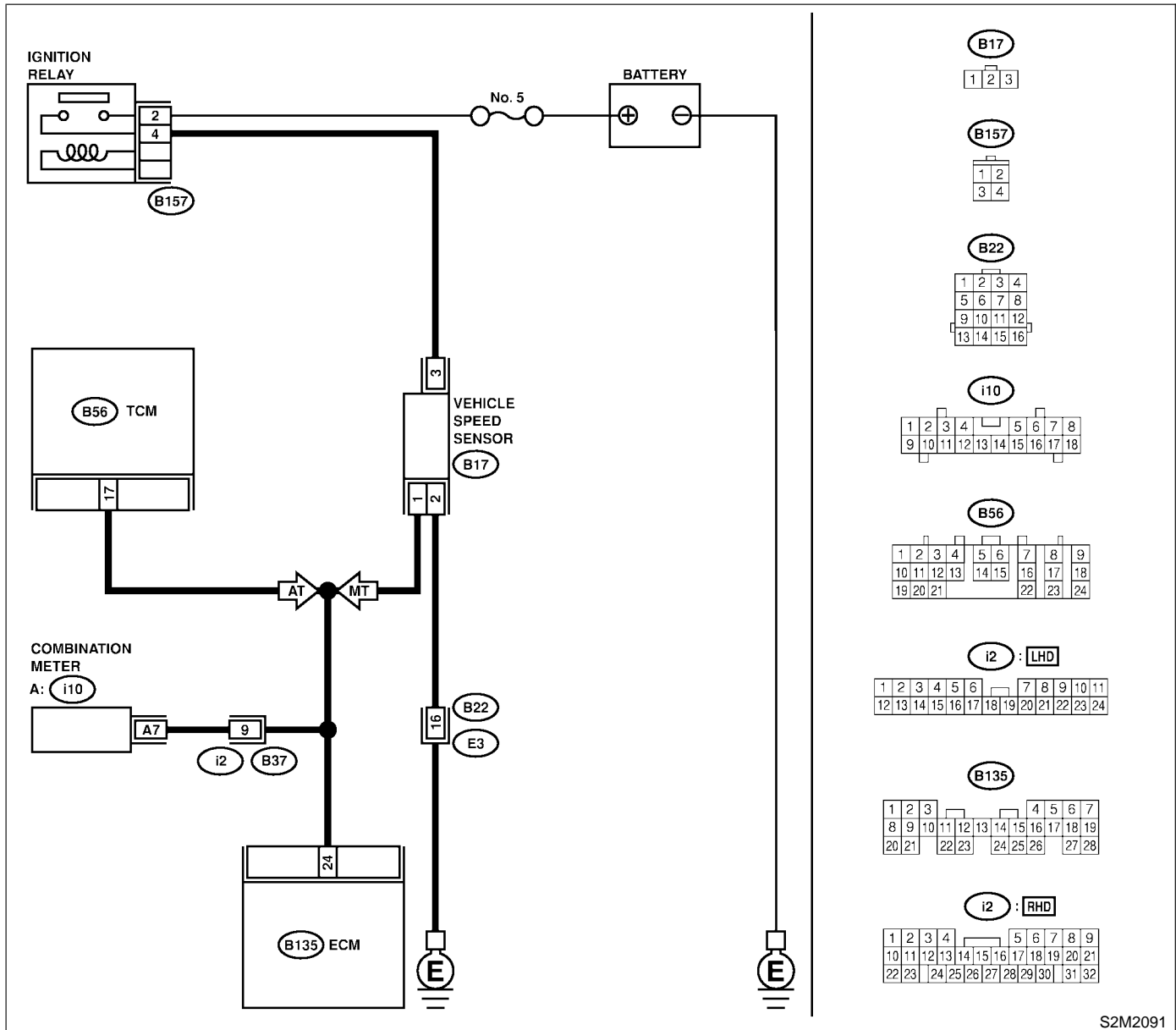

S2M2091

No.	Step	Check	Yes	No
1	CHECK TRANSMISSION TYPE.	Is the transmission type AT?	Go to step 2.	Go to step 3.



# DIAGNOSTIC PROCEDURE WITH DIAGNOSTIC TROUBLE CODE (DTC)

Engine (Diagnostics)

No.	Step	Check	Yes	No
2	<b>CHECK DTC P0720 ON DISPLAY.</b>	Does the Subaru Select Monitor or OBD-II general scan tool indicate DTC P0720?	Check front vehicle speed sensor signal circuit. <Ref. to AT-58, TROUBLE CODE 33 — FRONT VEHICLE SPEED SENSOR —, Diagnostic Procedure with Trouble Code.>	Go to step 3.
3	<b>CHECK SPEEDOMETER OPERATION IN COMBINATION METER.</b>	Does speedometer operate normally?	Go to step 4.	Check speedometer and vehicle speed sensor. <Ref. to IDI-17, Speedometer.> and <Ref. to AT-32, Front Vehicle Speed Sensor.> and <Ref. to AT-36, Rear Vehicle Speed Sensor.> and <Ref. to AT-37, Torque Converter Turbine Speed Sensor.>
4	<b>CHECK HARNESS BETWEEN ECM AND COMBINATION METER CONNECTOR.</b> 1) Turn ignition switch to OFF. 2) Disconnect connector from combination meter. 3) Measure resistance between ECM and combination meter. <b>Connector &amp; terminal</b> <b>(B135) No. 24 — (i10) No. 7:</b>	Is the resistance less than 10 Ω?	Repair poor contact in ECM connector.	Repair harness and connector. <b>NOTE:</b> In this case, repair the following: ● Open circuit in harness between ECM and combination meter connector ● Poor contact in ECM connector ● Poor contact in combination meter connector ● Poor contact in coupling connector (i2)

# DIAGNOSTIC PROCEDURE WITH DIAGNOSTIC TROUBLE CODE (DTC)

Engine (Diagnostics)

## AT: DTC P0506 — IDLE CONTROL SYSTEM RPM LOWER THAN EXPECTED

S058521B61

### ● DTC DETECTING CONDITION:

- Two consecutive driving cycles with fault

### ● TROUBLE SYMPTOM:

- Engine is difficult to start.
- Engine does not start.
- Erroneous idling
- Engine stalls.

### CAUTION:

After repair or replacement of faulty parts, conduct Clear Memory Mode <Ref. to EN(SOHC)-45, OPERATION, Clear Memory Mode.> and Inspection Mode <Ref. to EN(SOHC)-42, OPERATION, Inspection Mode.>.

### ● WIRING DIAGRAM:

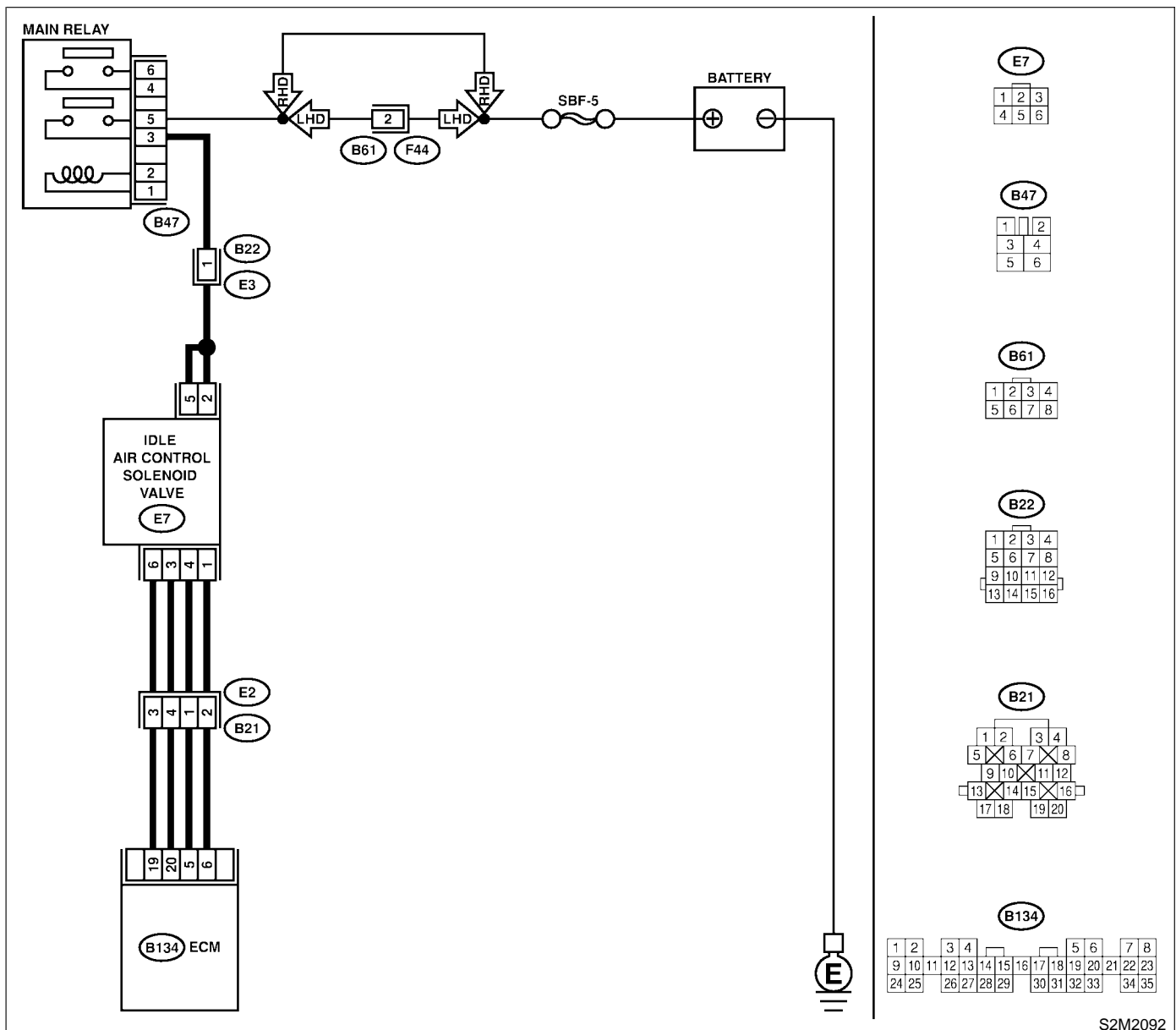

S2M2092

# DIAGNOSTIC PROCEDURE WITH DIAGNOSTIC TROUBLE CODE (DTC)

Engine (Diagnostics)

No.	Step	Check	Yes	No
1	<b>CHECK ANY OTHER DTC ON DISPLAY.</b>	Does the Subaru Select Monitor or OBD-II general scan tool indicate DTC P1510, P1511, P1512, P1513, P1514, P1515, P1516 or P1517?	Inspect DTC P1510, P1511, P1512, P1513, P1514, P1515, P1516 or P1517 using "17. List of Diagnostic Trouble Code (DTC)". <Ref. to EN(SOHC)-80, List of Diagnostic Trouble Code (DTC).> NOTE: In this case, it is not necessary to inspect DTC P0506.	Go to step 2.
2	<b>CHECK AIR BY-PASS LINE.</b> 1) Turn ignition switch to OFF. 2) Remove idle air control solenoid valve from throttle body. <Ref. to FU(SOHC)-38, REMOVAL, Idle Air Control Solenoid Valve.> 3) Remove throttle body from intake manifold. <Ref. to FU(SOHC)-14, REMOVAL, Throttle Body.> 4) Using an air gun, force air into idle air control solenoid valve installation area. Confirm that forced air subsequently escapes from throttle body interior.	Does air flow out?	Replace idle air control solenoid valve. <Ref. to FU(SOHC)-38, INSTALLATION, Idle Air Control Solenoid Valve.>	Replace throttle body. <Ref. to FU(SOHC)-14, INSTALLATION, Throttle Body.>

# DIAGNOSTIC PROCEDURE WITH DIAGNOSTIC TROUBLE CODE (DTC)

Engine (Diagnostics)

## AU: DTC P0507 — IDLE CONTROL SYSTEM RPM HIGHER THAN EXPECTED

— S058521B62

### ● DTC DETECTING CONDITION:

- Two consecutive driving cycles with fault

### ● TROUBLE SYMPTOM:

- Engine keeps running at higher revolution than specified idling revolution.

### CAUTION:

After repair or replacement of faulty parts, conduct Clear Memory Mode <Ref. to EN(SOHC)-45, OPERATION, Clear Memory Mode.> and Inspection Mode <Ref. to EN(SOHC)-42, OPERATION, Inspection Mode.>.

### ● WIRING DIAGRAM:

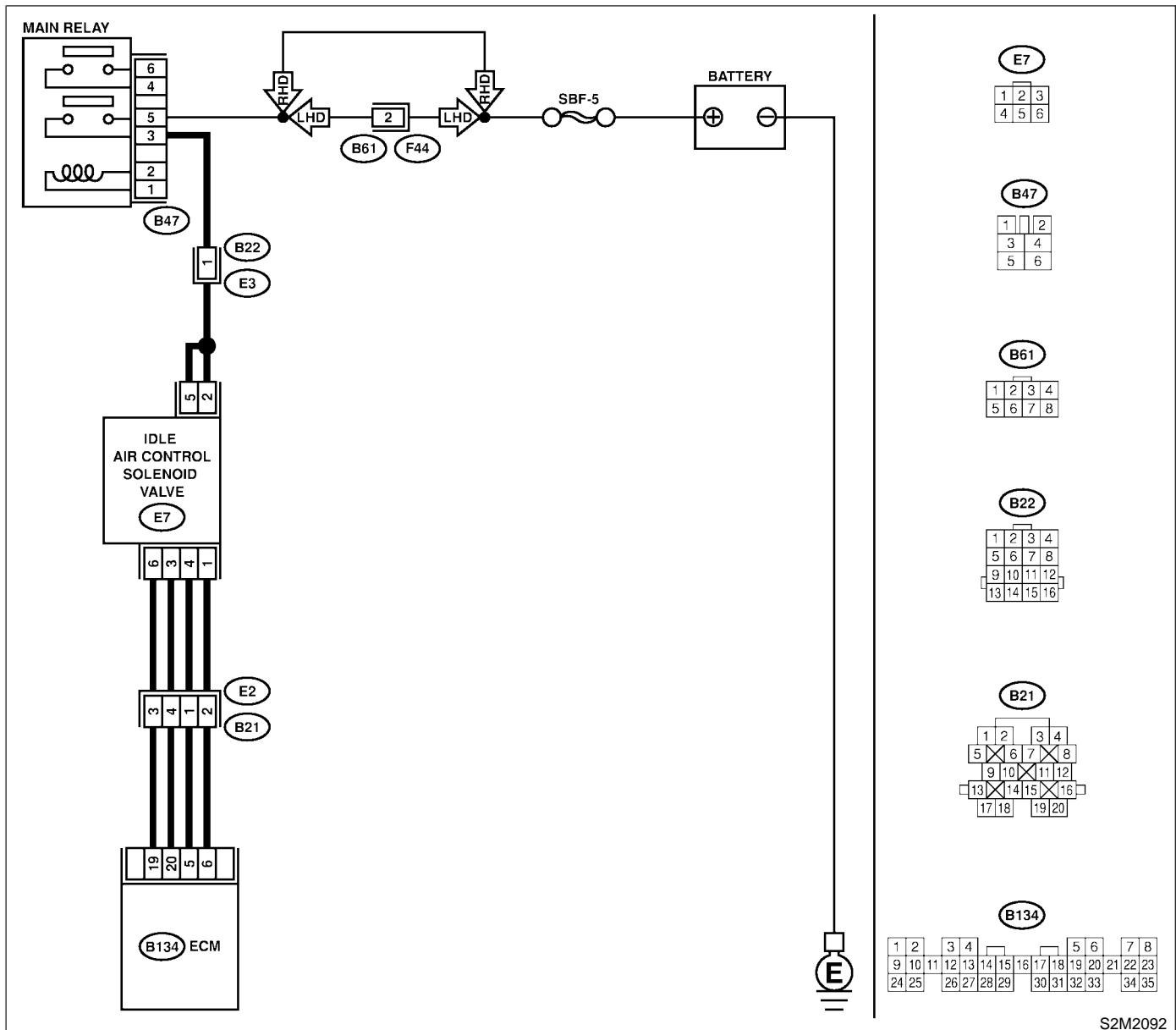

S2M2092

# DIAGNOSTIC PROCEDURE WITH DIAGNOSTIC TROUBLE CODE (DTC)

Engine (Diagnostics)

No.	Step	Check	Yes	No
1	<b>CHECK ANY OTHER DTC ON DISPLAY.</b>	Does the Subaru Select Monitor or OBD-II general scan tool indicate DTC P1510, P1511, P1512, P1513, P1514, P1515, P1516 or P1517?	Inspect DTC P1510, P1511, P1512, P1513, P1514, P1515, P1516 or P1517 using "17. List of Diagnostic Trouble Code (DTC)". <Ref. to EN(SOHC)-80, List of Diagnostic Trouble Code (DTC).> NOTE: In this case, it is not necessary to inspect DTC P0507.	Go to step 2.
2	<b>CHECK AIR INTAKE SYSTEM.</b> 1) Turn ignition switch to ON. 2) Start engine, and idle it. 3) Check the following items. ● Loose installation of intake manifold, idle air control solenoid valve and throttle body ● Cracks of intake manifold gasket, idle air control solenoid valve gasket and throttle body gasket ● Disconnections of vacuum hoses	Is there a fault in air intake system?	Repair air suction and leaks.	Go to step 3.
3	<b>CHECK THROTTLE CABLE.</b>	Does throttle cable have play for adjustment?	Go to step 4.	Adjust throttle cable. <Ref. to SP-12, INSTALLATION, Accelerator Control Cable.>
4	<b>CHECK AIR BY-PASS LINE.</b> 1) Turn ignition switch to OFF. 2) Remove idle air control solenoid valve from throttle body. <Ref. to FU(SOHC)-38, REMOVAL, Idle Air Control Solenoid Valve.> 3) Confirm that there are no foreign particles in by-pass air line.	Are foreign particles in by-pass air line?	Remove foreign particles from by-pass air line.	Replace idle air control solenoid valve. <Ref. to FU(SOHC)-38, INSTALLATION, Idle Air Control Solenoid Valve.>

# DIAGNOSTIC PROCEDURE WITH DIAGNOSTIC TROUBLE CODE (DTC)

Engine (Diagnostics)

## AV: DTC P0512 — STARTER SWITCH CIRCUIT HIGH INPUT — S058521G02

- **DTC DETECTING CONDITION:**
  - Two consecutive driving cycles with fault
- **TROUBLE SYMPTOM:**
  - Failure of engine to start

**CAUTION:**

After repair or replacement of faulty parts, conduct Clear Memory Mode <Ref. to EN(SOHC)-45, OPERATION, Clear Memory Mode.> and Inspection Mode <Ref. to EN(SOHC)-42, OPERATION, Inspection Mode.>.

● **WIRING DIAGRAM:**

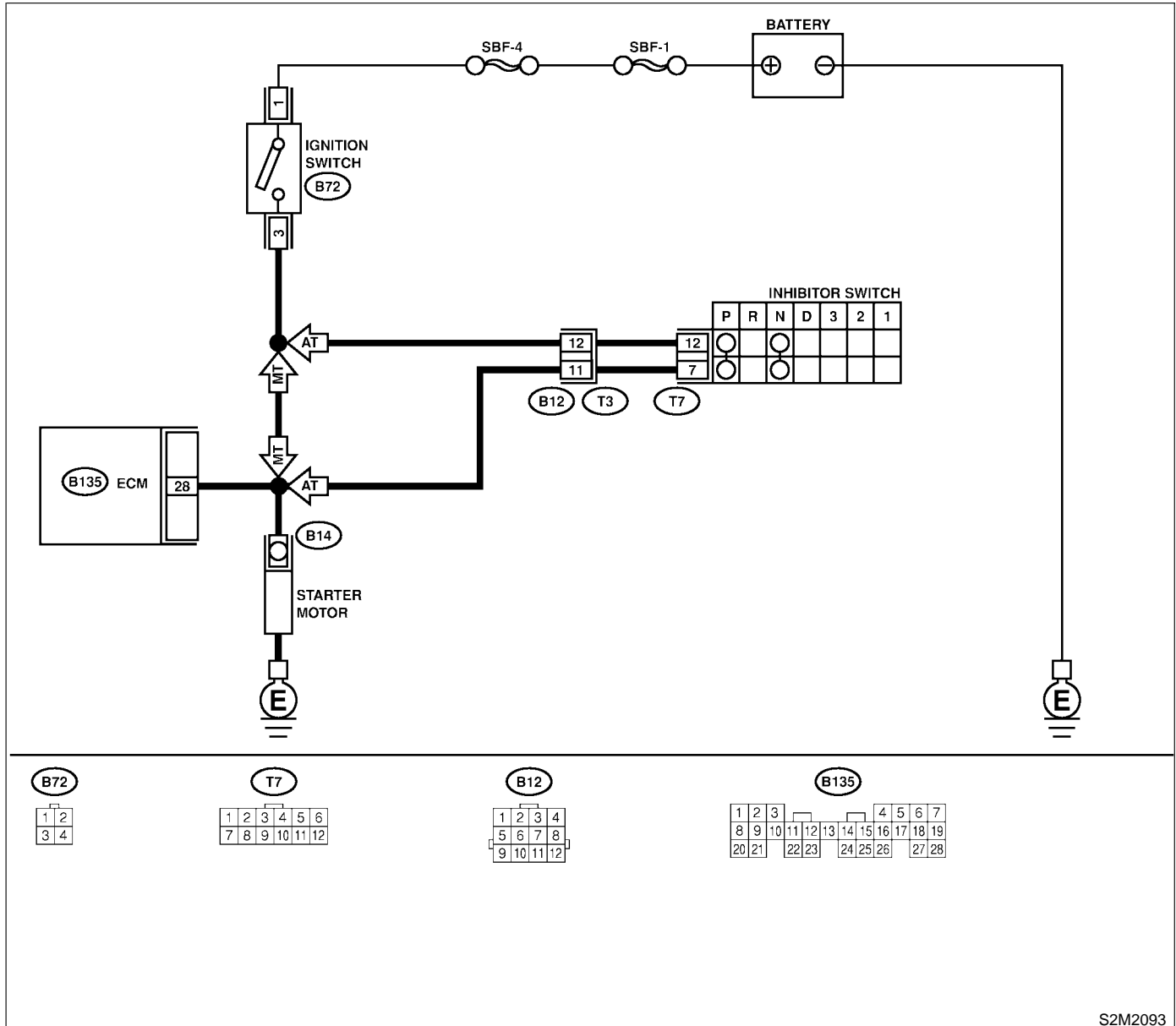

S2M2093

# DIAGNOSTIC PROCEDURE WITH DIAGNOSTIC TROUBLE CODE (DTC)

Engine (Diagnostics)

No.	Step	Check	Yes	No
1	<b>CHECK OPERATION OF STARTER MOTOR.</b> NOTE: Place the inhibitor switch in each position.	Does starter motor operate when ignition switch to "ON"?	Repair battery short circuit in starter motor circuit. After repair, replace ECM. <Ref. to FU(SOHC)-49, Engine Control Module.>	Check starter motor circuit. <Ref. to EN(SOHC)-60, STARTER MOTOR CIRCUIT, Diagnostics for Engine Starting Failure.>

# DIAGNOSTIC PROCEDURE WITH DIAGNOSTIC TROUBLE CODE (DTC)

Engine (Diagnostics)

## AW: DTC P0562 — CHARGE SYSTEM CIRCUIT LOW INPUT — S058521G81

### ● DTC DETECTING CONDITION:

- Power source voltage of the ECM is low.

### ● TROUBLE SYMPTOM:

- Charge warning light comes on.

### CAUTION:

After repair or replacement of faulty parts, conduct Clear Memory Mode <Ref. to EN(SOHC)-45, OPERATION, Clear Memory Mode.> and Inspection Mode <Ref. to EN(SOHC)-42, OPERATION, Inspection Mode.>.

### ● WIRING DIAGRAM:

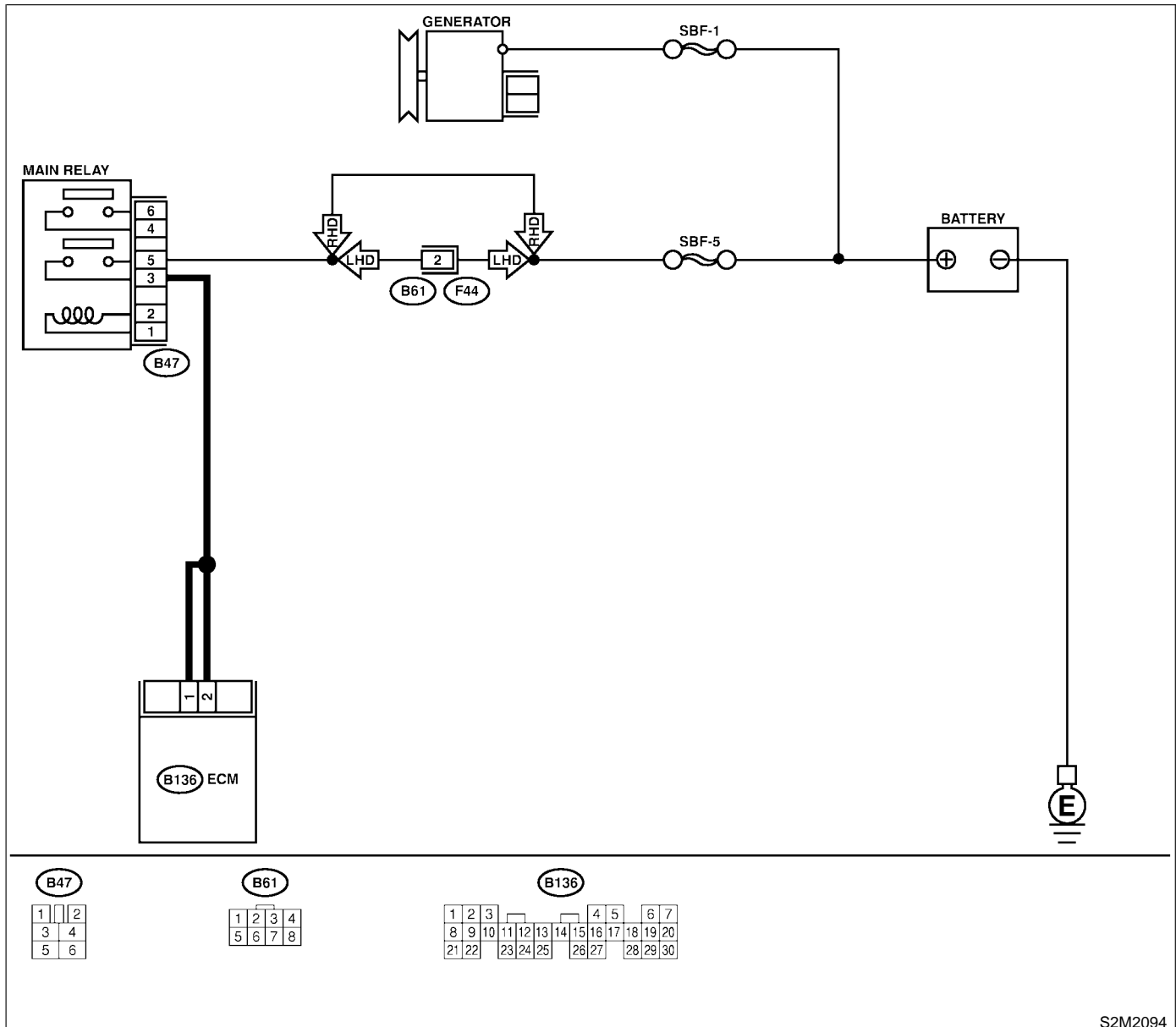

S2M2094



# DIAGNOSTIC PROCEDURE WITH DIAGNOSTIC TROUBLE CODE (DTC)

Engine (Diagnostics)

No.	Step	Check	Yes	No
1	<b>CHECK GENERATOR.</b> 1) Start engine. 2) Idling after warm-up. 3) Measure voltage between generator B terminal and chassis ground. <i>Terminal</i> <b>Generator B terminal (+) — Chassis ground (-):</b>	Is the voltage less than 10.8 V?	Go to step 2.	Repair generator. <Ref. to SC-12, Generator.>
2	<b>CHECK GENERATOR.</b> 1) Run engine at 5,000 rpm. 2) Measure voltage between generator B terminal and chassis ground. <i>Terminal</i> <b>Generator B terminal (+) — Chassis ground (-):</b>	Is the voltage less than 10.8 V?	Go to step 3.	Repair generator. <Ref. to SC-12, Generator.>
3	<b>CHECK BATTERY TERMINAL.</b> Turn ignition switch to OFF.	Are the positive and negative battery terminals tightly clamped?	Go to step 4.	Tighten the clamp of terminal.
4	<b>CHECK INPUT VOLTAGE OF ECM.</b> 1) Run the engine at idle. 2) Measure voltage between ECM connector and chassis ground. <i>Connector &amp; terminal</i> <b>(B136) No. 1 (+) — Chassis ground (-):</b> <b>(B136) No. 2 (+) — Chassis ground (-):</b>	Is the voltage less than 10.8 V?	Go to step 5.	Repair harness connector between battery, main relay and ECM.
5	<b>CHECK POOR CONTACT IN CONNECTORS.</b>	Is there poor contact in connectors between generator, battery and ECM?	Repair connector.	Go to step 6.
6	<b>CHECK ECM.</b> 1) Connect all connectors. 2) Erase the memory. <Ref. to EN(SOHC)-45, Clean Memory Mode.> 3) Perform inspection mode. <Ref. to EN(SOHC)-42, Inspection Mode.> 4) Read out the trouble code. <Ref. to EN(SOHC)-41, Read Diagnostic Trouble Code.>	Is the same trouble code as in the current diagnosis still being output?	Replace generator.	Go to step 7.
7	<b>CHECK ANY OTHER TROUBLE CODES APPEARANCE.</b>	Are other trouble codes being output?	Proceed with the diagnosis corresponding to the trouble code.	A temporary poor contact.

# DIAGNOSTIC PROCEDURE WITH DIAGNOSTIC TROUBLE CODE (DTC)

Engine (Diagnostics)

## AX: DTC P0563 — CHARGE SYSTEM CIRCUIT HIGH INPUT —

S058521G82

### ● DTC DETECTING CONDITION:

- Power source voltage of the ECM is high.

### ● TROUBLE SYMPTOM:

- Charge warning light comes on.

### CAUTION:

After repair or replacement of faulty parts, conduct Clear Memory Mode <Ref. to EN(SOHC)-45, OPERATION, Clear Memory Mode.> and Inspection Mode <Ref. to EN(SOHC)-42, OPERATION, Inspection Mode.>.

### ● WIRING DIAGRAM:

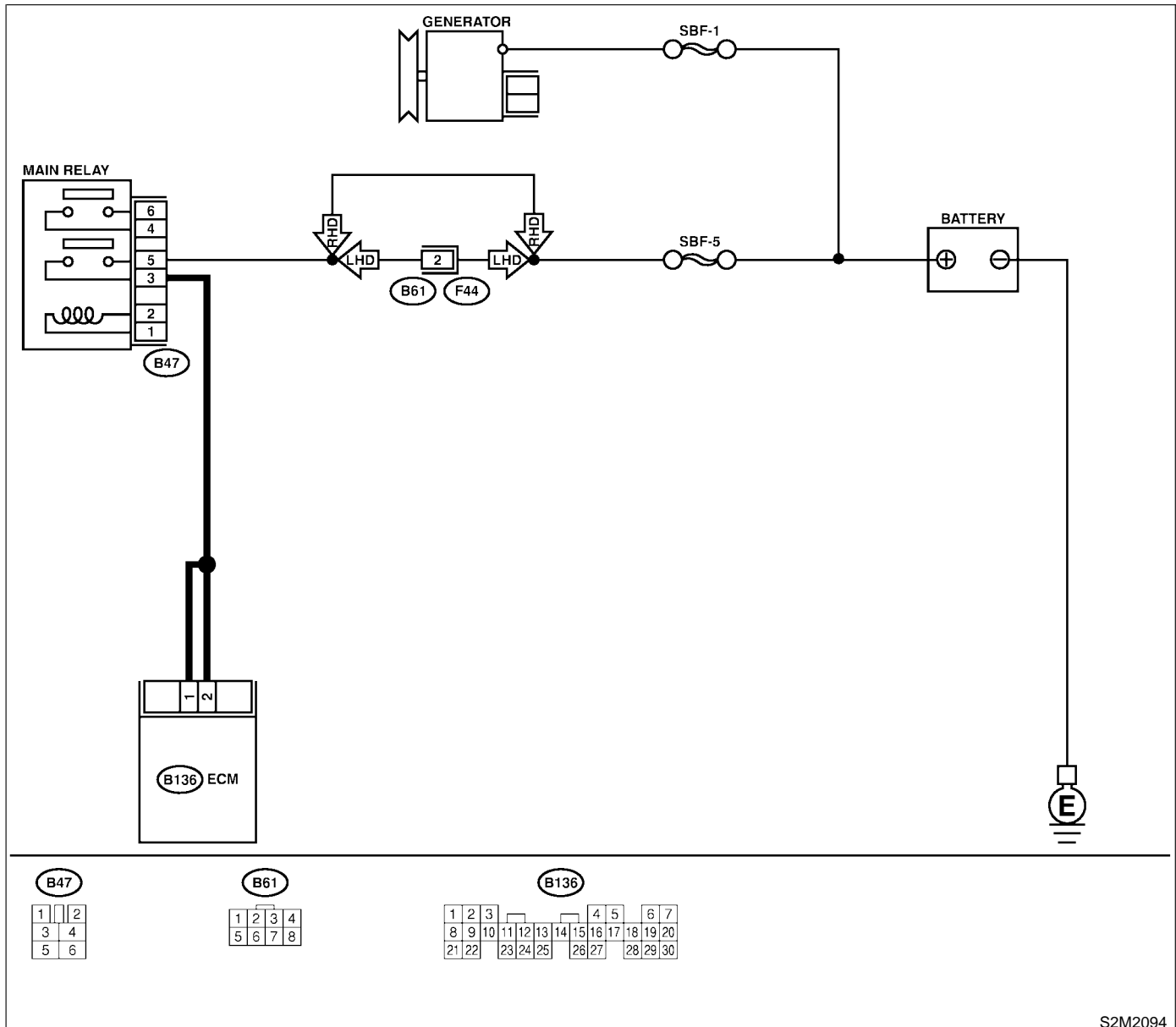

S2M2094

# DIAGNOSTIC PROCEDURE WITH DIAGNOSTIC TROUBLE CODE (DTC)

Engine (Diagnostics)

No.	Step	Check	Yes	No
1	<b>CHECK GENERATOR.</b> 1) Start engine. 2) Idling after warm-up. 3) Measure voltage between generator B terminal and chassis ground. <i>Terminal</i> <b>Generator B terminal (+) — Chassis ground (-):</b>	Is the voltage more than 16.2 V?	Go to step 2.	Repair generator. <Ref. to SC-12, Generator.>
2	<b>CHECK GENERATOR.</b> 1) Run engine at 5,000 rpm. 2) Measure voltage between generator B terminal and chassis ground. <i>Terminal</i> <b>Generator B terminal (+) — Chassis ground (-):</b>	Is the voltage more than 16.2 V?	Go to step 3.	Repair generator. <Ref. to SC-12, Generator.>
3	<b>CHECK BATTERY TERMINAL.</b> Turn ignition switch to OFF.	Are the positive and negative battery terminals tightly clamped?	Go to step 4.	Tighten the clamp of terminal.
4	<b>CHECK INPUT VOLTAGE OF ECM.</b> 1) Run the engine at idle. 2) Measure voltage between ECM connector and chassis ground. <i>Connector &amp; terminal</i> <b>(B136) No. 1 (+) — Chassis ground (-):</b> <b>(B136) No. 2 (+) — Chassis ground (-):</b>	Is the voltage more than 16.2 V?	Go to step 5.	Repair harness connector between battery, main relay and ECM.
5	<b>CHECK POOR CONTACT IN CONNECTORS.</b>	Is there poor contact in connectors between generator, battery and ECM?	Repair connector.	Go to step 6.
6	<b>CHECK ECM.</b> 1) Connect all connectors. 2) Erase the memory. <Ref. to EN(SOHC)-45, Clear Memory Mode.> 3) Perform inspection mode. <Ref. to EN(SOHC)-42, Inspection Mode.> 4) Read out the trouble code. <Ref. to EN(SOHC)-41, Read Diagnostic Trouble Code.>	Is the same trouble code as in the current diagnosis still being output?	Replace generator.	Go to step 7.
7	<b>CHECK ANY OTHER TROUBLE CODES APPEARANCE.</b>	Are other trouble codes being output?	Proceed with the diagnosis corresponding to the trouble code.	A temporary poor contact.

# DIAGNOSTIC PROCEDURE WITH DIAGNOSTIC TROUBLE CODE (DTC)

Engine (Diagnostics)

## AY: DTC P0604 — INTERNAL CONTROL MODULE MEMORY CHECK SUM ERROR — S058521G03

### ● DTC DETECTING CONDITION:

- Two consecutive driving cycles with fault

### ● TROUBLE SYMPTOM:

- Engine does not start.
- Engine stalls.

### CAUTION:

After repair or replacement of faulty parts, conduct Clear Memory Mode <Ref. to EN(SOHC)-45, OPERATION, Clear Memory Mode.> and Inspection Mode <Ref. to EN(SOHC)-42, OPERATION, Inspection Mode.>.

### ● WIRING DIAGRAM:

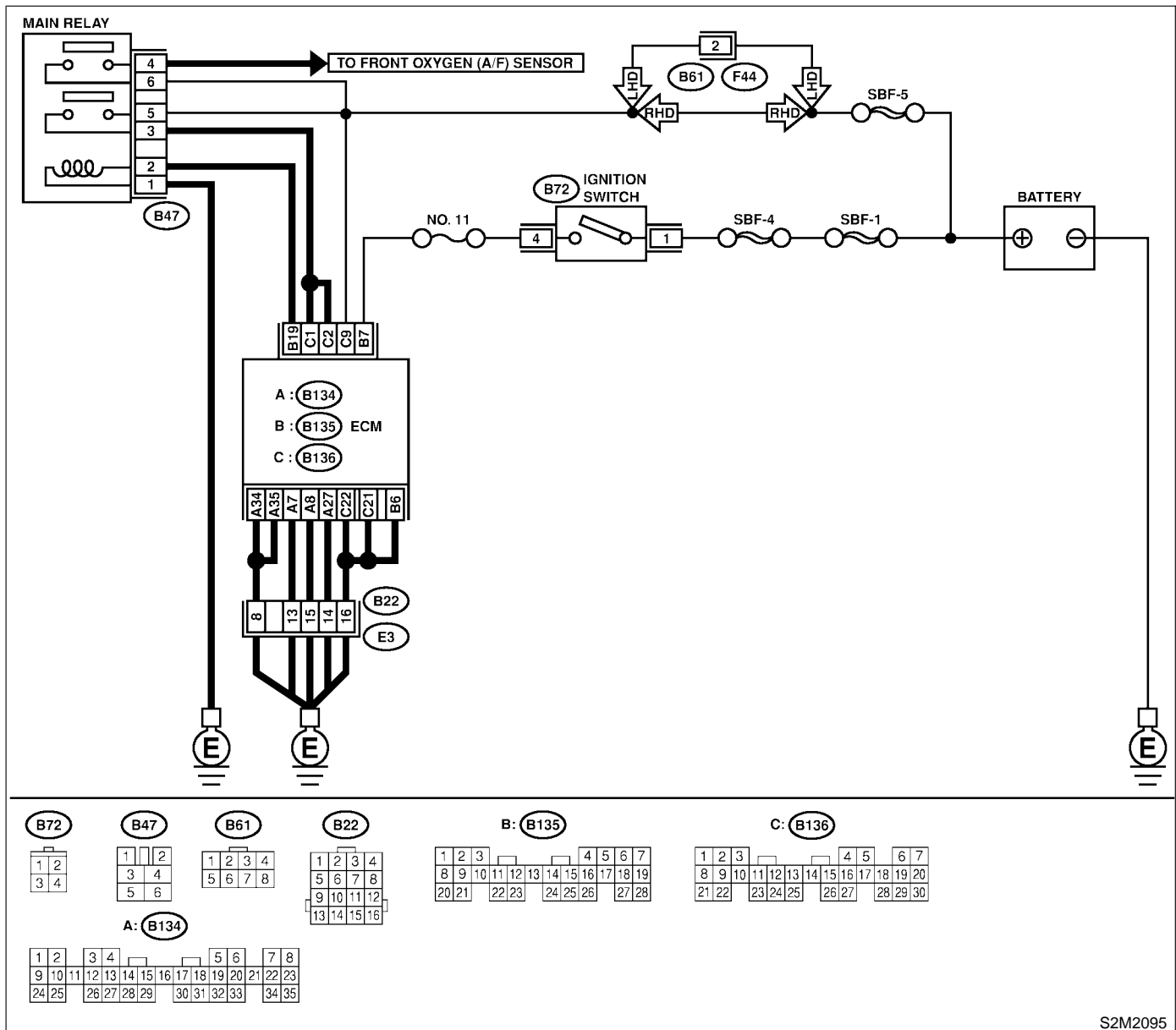

S2M2095

# DIAGNOSTIC PROCEDURE WITH DIAGNOSTIC TROUBLE CODE (DTC)

Engine (Diagnostics)

No.	Step	Check	Yes	No
1	CHECK ANY OTHER DTC ON DISPLAY.	Does the Subaru Select Monitor or OBD-II general scan tool indicate DTC P0601?	Replace ECM. <Ref. to FU(SOHC)-49, Engine Control Module.>	It is not necessary to inspect DTC P0601.

# DIAGNOSTIC PROCEDURE WITH DIAGNOSTIC TROUBLE CODE (DTC)

Engine (Diagnostics)

## AZ: DTC P0703 — BRAKE SWITCH INPUT MALFUNCTION — S058521B64

### ● DTC DETECTING CONDITION:

- Two consecutive driving cycles with fault

### CAUTION:

After repair or replacement of faulty parts, conduct Clear Memory Mode <Ref. to EN(SOHC)-45, OPERATION, Clear Memory Mode.> and Inspection Mode <Ref. to EN(SOHC)-42, OPERATION, Inspection Mode.>.

### ● WIRING DIAGRAM:

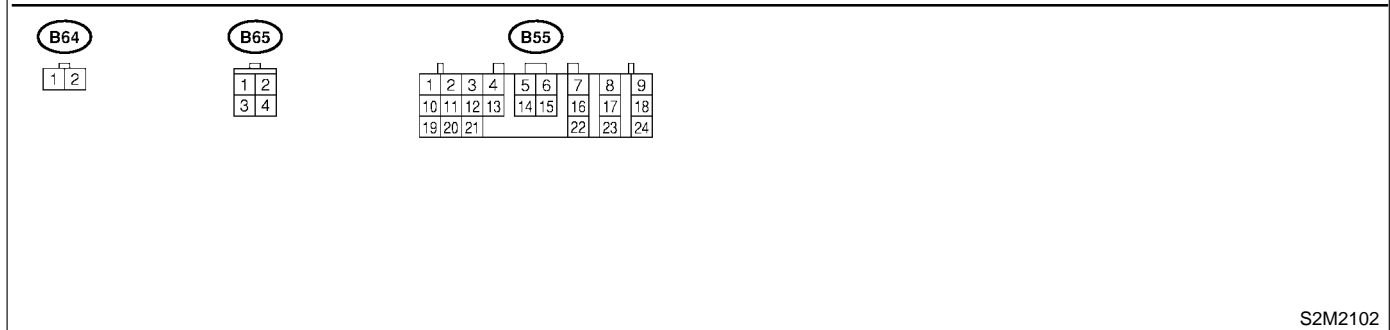
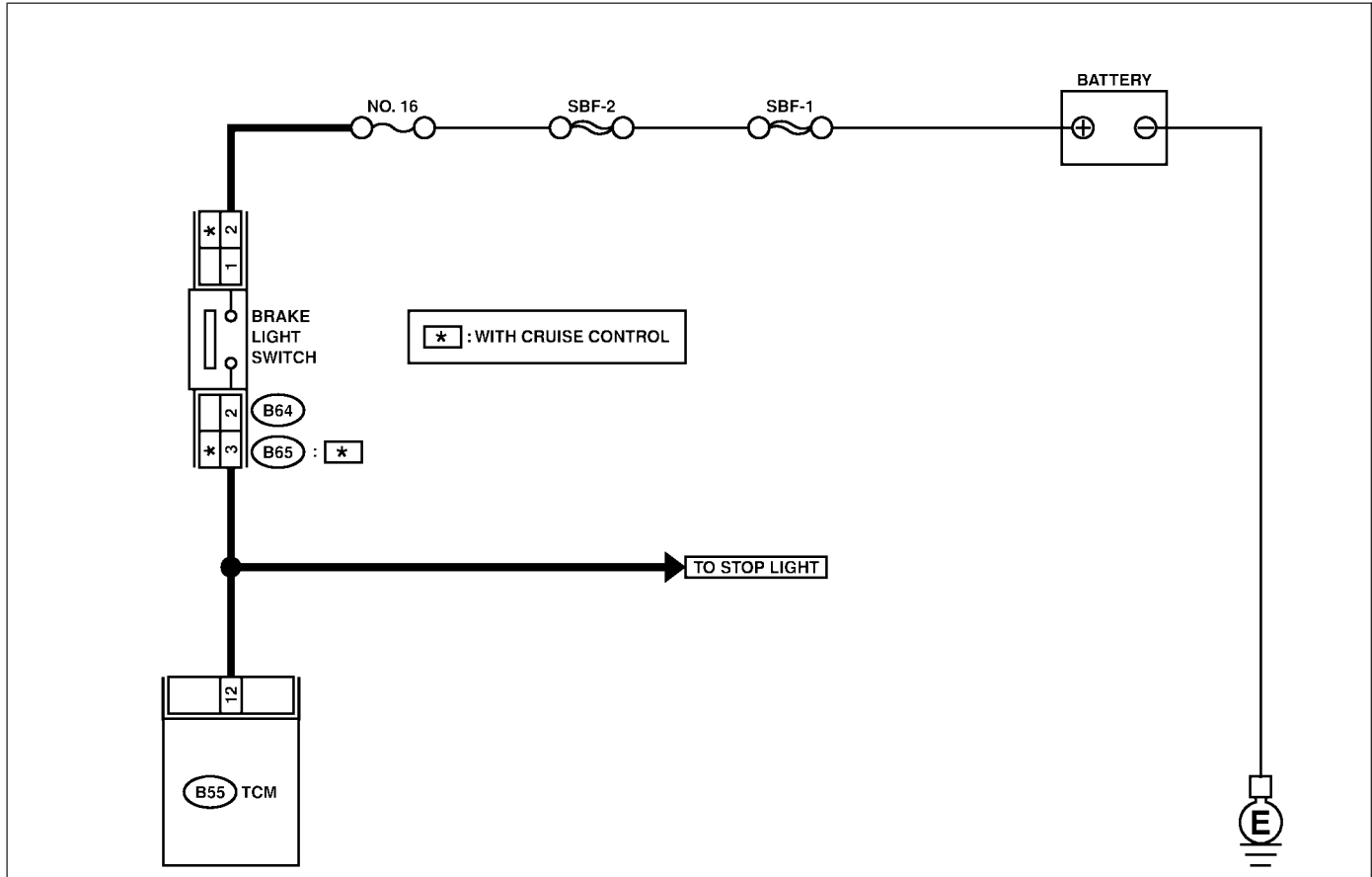

S2M2102

No.	Step	Check	Yes	No
1	CHECK OPERATION OF BRAKE LIGHT.	Does brake light come on when depressing the brake pedal?	Go to step 2.	Repair or replace brake light circuit.

# DIAGNOSTIC PROCEDURE WITH DIAGNOSTIC TROUBLE CODE (DTC)

Engine (Diagnostics)

No.	Step	Check	Yes	No
2	<p><b>CHECK HARNESS BETWEEN TCM AND BRAKE LIGHT SWITCH CONNECTOR.</b></p> <p>1) Disconnect connectors from TCM and brake light switch.</p> <p>2) Measure resistance of harness between TCM and brake light switch connector.</p> <p><b>Connector &amp; terminal</b>  <b>(B55) No. 12 — (B64) No. 2:</b>  <b>(B55) No. 12 — (B65) No. 3 (With cruise control):</b></p>	Is the resistance less than 1 Ω?	Go to step 3.	<p>Repair or replace harness and connector.</p> <p>NOTE: In this case, repair the following:</p> <ul style="list-style-type: none"> <li>● Open circuit in harness between TCM and brake light switch connector</li> <li>● Poor contact in TCM connector</li> <li>● Poor contact in brake light switch connector</li> </ul>
3	<p><b>CHECK HARNESS BETWEEN TCM AND BRAKE LIGHT SWITCH CONNECTOR.</b></p> <p>Measure resistance of harness between TCM and chassis ground.</p> <p><b>Connector &amp; terminal</b>  <b>(B55) No. 12 — Chassis ground:</b></p>	Is the resistance more than 1 MΩ?	Go to step 4.	Repair ground short circuit in harness between TCM and brake light switch connector.
4	<p><b>CHECK INPUT SIGNAL FOR TCM.</b></p> <p>1) Connect connectors to TCM and brake light switch.</p> <p>2) Measure voltage between TCM and chassis ground.</p> <p><b>Connector &amp; terminal</b>  <b>(B55) No. 12 (+) — Chassis ground (-):</b></p>	Is the voltage less than 1 V when releasing the brake pedal?	Go to step 5.	Adjust or replace brake light switch. <Ref. to LI-31, STOP LIGHT SWITCH, INSPECTION, Stop Light System.>
5	<p><b>CHECK INPUT SIGNAL FOR TCM.</b></p> <p>Measure voltage between TCM and chassis ground.</p> <p><b>Connector &amp; terminal</b>  <b>(B55) No. 12 (+) — Chassis ground (-):</b></p>	Is the voltage more than 10 V when depressing the brake pedal?	Go to step 6.	Adjust or replace brake light switch. <Ref. to LI-31, STOP LIGHT SWITCH, INSPECTION, Stop Light System.>
6	<p><b>CHECK POOR CONTACT.</b></p> <p>Check poor contact in TCM connector.</p>	Is there poor contact in TCM connector?	Repair poor contact in TCM connector.	Replace TCM. <Ref. to AT-48, Transmission Control Module.>

# DIAGNOSTIC PROCEDURE WITH DIAGNOSTIC TROUBLE CODE (DTC)

Engine (Diagnostics)

---

## **BA: DTC P0731 — GEAR 1 INCORRECT RATIO —** S058521B70

NOTE:

For the diagnostic procedure, refer to DTC P0734. <Ref. to EN(SOHC)-225, DTC P0734 — GEAR 4 INCORRECT RATIO —, Diagnostic Procedure with Diagnostic Trouble Code (DTC).>

## **BB: DTC P0732 — GEAR 2 INCORRECT RATIO —** S058521B71

NOTE:

For the diagnostic procedure, refer to DTC P0734. <Ref. to EN(SOHC)-225, DTC P0734 — GEAR 4 INCORRECT RATIO —, Diagnostic Procedure with Diagnostic Trouble Code (DTC).>

## **BC: DTC P0733 — GEAR 3 INCORRECT RATIO —** S058521B72

NOTE:

For the diagnostic procedure, refer to DTC P0734. <Ref. to EN(SOHC)-225, DTC P0734 — GEAR 4 INCORRECT RATIO —, Diagnostic Procedure with Diagnostic Trouble Code (DTC).>



# DIAGNOSTIC PROCEDURE WITH DIAGNOSTIC TROUBLE CODE (DTC)

Engine (Diagnostics)

## BD: DTC P0734 — GEAR 4 INCORRECT RATIO — S058521B73

● **DTC DETECTING CONDITION:**

- Two consecutive driving cycles with fault

● **TROUBLE SYMPTOM:**

- Shift point too high or too low; engine brake not effected in “3” range; excessive shift shock; excessive tight corner “braking”

**CAUTION:**

After repair or replacement of faulty parts, conduct Clear Memory Mode <Ref. to EN(SOHC)-45, OPERATION, Clear Memory Mode.> and Inspection Mode <Ref. to EN(SOHC)-42, OPERATION, Inspection Mode.>.

● **WIRING DIAGRAM:**

No.	Step	Check	Yes	No
1	<b>CHECK ANY OTHER DTC ON DISPLAY.</b>	Is there any other DTC on display?	Inspect relevant DTC using “17. List of Diagnostic Trouble Code (DTC)”. <Ref. to EN(SOHC)-80, List of Diagnostic Trouble Code (DTC).>	Go to step 2.
2	<b>CHECK THROTTLE POSITION SENSOR CIRCUIT.</b> Check throttle position sensor circuit. <Ref. to AT-50, TROUBLE CODE 31 — THROTTLE POSITION SENSOR —, Diagnostic Procedure with Trouble Code.>	Is there any trouble in throttle position sensor circuit?	Repair or replace throttle position sensor circuit.	Go to step 3.
3	<b>CHECK FRONT VEHICLE SPEED SENSOR CIRCUIT.</b> Check front vehicle speed sensor circuit. <Ref. to AT-58, TROUBLE CODE 33 — FRONT VEHICLE SPEED SENSOR —, Diagnostic Procedure with Trouble Code.>	Is there any trouble in vehicle speed sensor 2 circuit?	Repair or replace vehicle speed sensor 2 circuit.	Go to step 4.
4	<b>CHECK TORQUE CONVERTER TURBINE SPEED SENSOR CIRCUIT.</b> Check torque converter turbine speed sensor circuit. <Ref. to AT-64, TROUBLE CODE 36 — TORQUE CONVERTER TURBINE SPEED SENSOR —, Diagnostic Procedure with Trouble Code.>	Is there any trouble in torque converter turbine speed sensor circuit?	Repair or replace torque converter turbine speed sensor circuit.	Go to step 5.
5	<b>CHECK POOR CONTACT.</b> Check poor contact in TCM connector.	Is there poor contact in TCM connector?	Repair poor contact in TCM connector.	Go to step 6.
6	<b>CHECK MECHANICAL TROUBLE.</b> Check mechanical trouble in automatic transmission.	Is there any mechanical trouble in automatic transmission?	Repair or replace automatic transmission. <Ref. to AT-12, INSPECTION, Road Test.>	Replace TCM. <Ref. to AT-48, Transmission Control Module (TCM).>

# DIAGNOSTIC PROCEDURE WITH DIAGNOSTIC TROUBLE CODE (DTC)

Engine (Diagnostics)

## BE: DTC P0741 — TORQUE CONVERTER CLUTCH SYSTEM MALFUNCTION

S058521G04

### ● DTC DETECTING CONDITION:

- Two consecutive driving cycles with fault

### ● TROUBLE SYMPTOM:

- No lock-up (after engine warm-up)
- No shift or excessive tight corner “braking”

### CAUTION:

After repair or replacement of faulty parts, conduct Clear Memory Mode <Ref. to EN(SOHC)-45, OPERATION, Clear Memory Mode.> and Inspection Mode <Ref. to EN(SOHC)-42, OPERATION, Inspection Mode.>.

No.	Step	Check	Yes	No
1	<b>CHECK ANY OTHER DTC ON DISPLAY.</b>	Is there any other DTC on display?	Inspect the relevant DTC using “17. List of Diagnostic Trouble Code (DTC)”. <Ref. to EN(SOHC)-80, List of Diagnostic Trouble Code (DTC).>	Go to step 2.
2	<b>CHECK LOCK-UP DUTY SOLENOID CIRCUIT.</b> Check lock-up duty solenoid circuit. <Ref. to AT-96, TROUBLE CODE 77 — LOCK-UP DUTY SOLENOID —, Diagnostic Procedure with Trouble Code.>	Is there any trouble in lock-up duty solenoid circuit?	Repair or replace lock-up duty solenoid circuit.	Go to step 3.
3	<b>CHECK THROTTLE POSITION SENSOR CIRCUIT.</b> Check throttle position sensor circuit. <Ref. to AT-50, TROUBLE CODE 31 — THROTTLE POSITION SENSOR —, Diagnostic Procedure with Trouble Code.>	Is there any trouble in throttle position sensor circuit?	Repair or replace throttle position sensor circuit.	Go to step 4.
4	<b>CHECK TORQUE CONVERTER TURBINE SPEED SENSOR CIRCUIT.</b> Check torque converter turbine speed sensor circuit. <Ref. to AT-64, TROUBLE CODE 36 — TORQUE CONVERTER TURBINE SPEED SENSOR —, Diagnostic Procedure with Trouble Code.>	Is there any trouble in torque converter turbine speed sensor circuit?	Repair or replace torque converter turbine speed sensor circuit.	Go to step 5.
5	<b>CHECK ENGINE SPEED INPUT CIRCUIT.</b> Check engine speed input circuit. <Ref. to AT-42, TROUBLE CODE 11 — ENGINE SPEED SIGNAL —, Diagnostic Procedure with Trouble Code.>	Is there any trouble in engine speed input circuit?	Repair or replace engine speed input circuit.	Go to step 6.
6	<b>CHECK INHIBITOR SWITCH CIRCUIT.</b> Check inhibitor switch circuit. <Ref. to AT-122, CHECK INHIBITOR SWITCH, Diagnostic Procedure for No-trouble Code.>	Is there any trouble in inhibitor switch circuit?	Repair or replace inhibitor switch circuit.	Go to step 7.
7	<b>CHECK BRAKE LIGHT SWITCH CIRCUIT.</b> Check brake light switch circuit. <Ref. to AT-111, CHECK BRAKE SWITCH, Diagnostic Procedure for No-trouble Code.>	Is there any trouble in brake light switch circuit?	Repair or replace brake light switch circuit.	Go to step 8.

# DIAGNOSTIC PROCEDURE WITH DIAGNOSTIC TROUBLE CODE (DTC)

Engine (Diagnostics)

No.	Step	Check	Yes	No
8	<b>CHECK ATF TEMPERATURE SENSOR CIRCUIT.</b> Check ATF temperature sensor circuit. <Ref. to AT-46, TROUBLE CODE 27 — ATF TEMPERATURE SENSOR —, Diagnostic Procedure with Trouble Code.>	Is there any trouble in ATF temperature sensor circuit?	Repair or replace ATF temperature sensor circuit.	Go to step 9.
9	<b>CHECK POOR CONTACT.</b> Check poor contact in TCM connector.	Is there poor contact in TCM connector?	Repair poor contact in TCM connector.	Go to step 10.
10	<b>CHECK MECHANICAL TROUBLE.</b> Check mechanical trouble in automatic transmission.	Is there any mechanical trouble in automatic transmission?	Repair or replace automatic transmission. <Ref. to AT-12, INSPECTION, Road Test.>	Replace TCM. <Ref. to AT-48, Transmission Control Module (TCM).>

# DIAGNOSTIC PROCEDURE WITH DIAGNOSTIC TROUBLE CODE (DTC)

Engine (Diagnostics)

## BF: DTC P1110 — ATMOSPHERIC PRESSURE SENSOR CIRCUIT LOW INPUT — S058521B84

- DTC DETECTING CONDITION:
  - Immediately at fault recognition

### CAUTION:

After repair or replacement of faulty parts, conduct Clear Memory Mode <Ref. to EN(SOHC)-45, OPERATION, Clear Memory Mode.> and Inspection Mode <Ref. to EN(SOHC)-42, OPERATION, Inspection Mode.>.

- WIRING DIAGRAM:

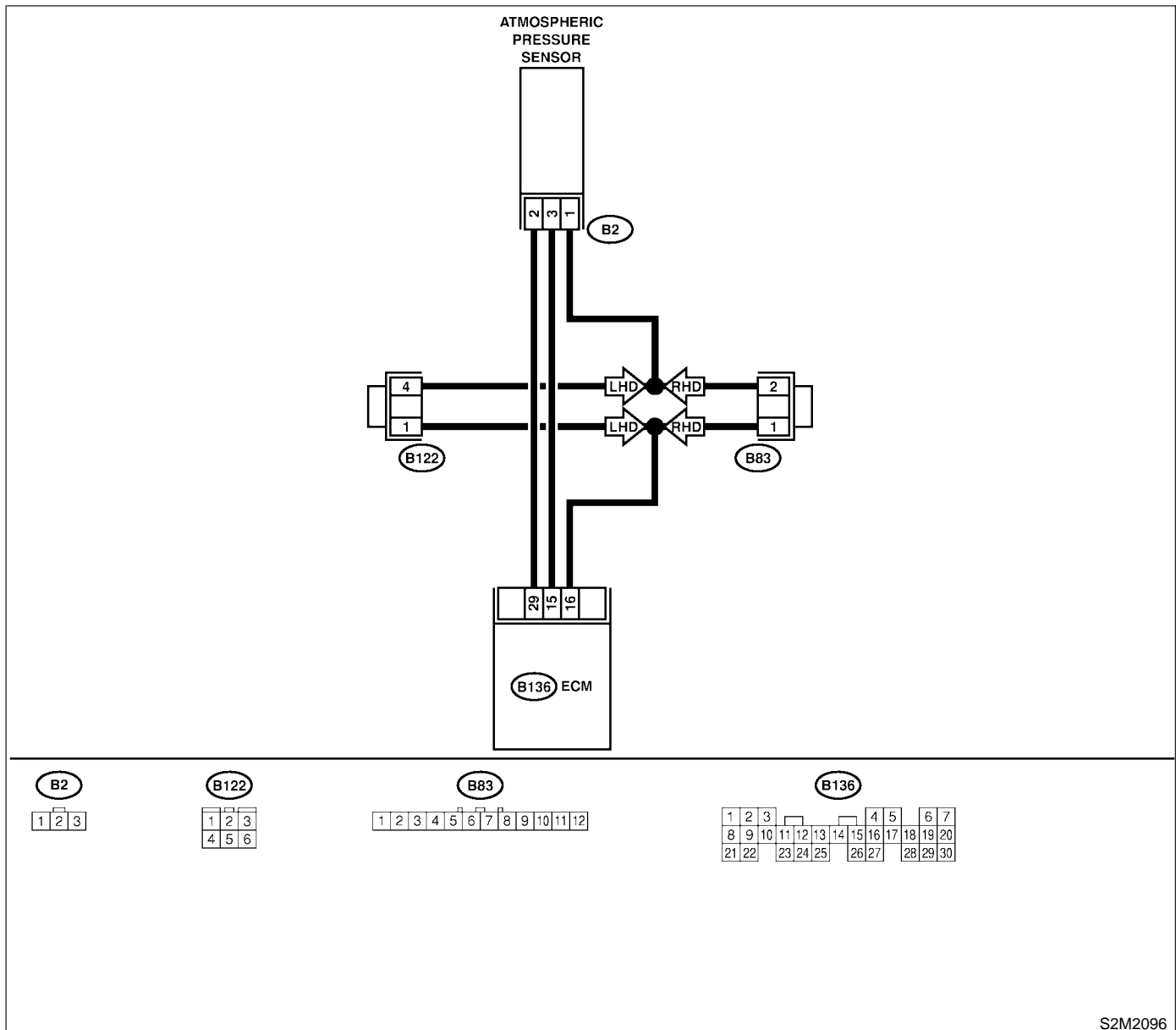

S2M2096

# DIAGNOSTIC PROCEDURE WITH DIAGNOSTIC TROUBLE CODE (DTC)

Engine (Diagnostics)

No.	Step	Check	Yes	No
1	<p><b>CHECK CURRENT DATA.</b>                      1) Start engine.                      2) Read the data of intake manifold absolute pressure signal using Subaru Select Monitor or OBD-II general scan tool.                      NOTE:                      ● Subaru Select Monitor                      For detailed operation procedure, refer to the "READ CURRENT DATA FOR ENGINE".                      &lt;Ref. to EN(SOHC)-34, Subaru Select Monitor.&gt;                      ● OBD-II general scan tool                      For detailed operation procedures, refer to the OBD-II General Scan Tool Instruction Manual.</p>	Is the value less than 0 kPa (0 mmHg, 0 inHg)?	Go to step 3.	Go to step 2.
2	<p><b>CHECK POOR CONTACT.</b>                      Check poor contact in ECM and pressure sensor connector.</p>	Is there poor contact in ECM or pressure sensor connector?	Repair poor contact in ECM or atmospheric pressure sensor connector.	Even if MIL lights up, the circuit has returned to a normal condition at this time.
3	<p><b>CHECK INPUT SIGNAL FOR ECM.</b>                      Measure voltage between ECM connector and chassis ground.  <b>Connector &amp; terminal</b>  <b>(B136) No. 15 (+) — Chassis ground (-):</b></p>	Is the voltage more than 4.5 V?	Go to step 5.	Go to step 4.
4	<p><b>CHECK INPUT SIGNAL FOR ECM.</b>                      Measure voltage between ECM connector and chassis ground.  <b>Connector &amp; terminal</b>  <b>(B136) No. 15 (+) — Chassis ground (-):</b></p>	Does the voltage change more than 4.5 V by shaking harness and connector of ECM while monitoring the value with voltage meter?	Repair poor contact in ECM connector.	Contact your Subaru distributor. NOTE: Inspection by DTM is required, because probable cause is deterioration of multiple parts.
5	<p><b>CHECK INPUT SIGNAL FOR ECM.</b>                      Measure voltage between ECM and chassis ground.  <b>Connector &amp; terminal</b>  <b>(B136) No. 29 (+) — Chassis ground (-):</b></p>	Is the voltage less than 0.2 V?	Go to step 7.	Go to step 6.
6	<p><b>CHECK INPUT SIGNAL FOR ECM. (USING SUBARU SELECT MONITOR.)</b>                      Read data of atmospheric absolute pressure signal using Subaru Select Monitor.                      NOTE:                      ● Subaru Select Monitor                      For detailed operation procedure, refer to the "READ CURRENT DATA FOR ENGINE".                      &lt;Ref. to EN(SOHC)-34, Subaru Select Monitor.&gt;</p>	Does the value change more than 0 kPa (0 mmHg, 0 inHg) by shaking harness and connector of ECM while monitoring the value with Subaru select monitor?	Repair poor contact in ECM connector.	Go to step 7.

# DIAGNOSTIC PROCEDURE WITH DIAGNOSTIC TROUBLE CODE (DTC)

Engine (Diagnostics)

No.	Step	Check	Yes	No
7	<p><b>CHECK HARNESS BETWEEN ECM AND ATMOSPHERIC PRESSURE SENSOR CONNECTOR.</b></p> <p>1) Turn ignition switch to OFF.                      2) Disconnect connector from atmospheric pressure sensor.                      3) Turn ignition switch to ON.                      4) Measure voltage between atmospheric pressure sensor connector and engine ground.</p> <p><b>Connector &amp; terminal</b>  <b>(B2) No. 3 (+) — Engine ground (-):</b></p>	Is the voltage more than 4.5 V?	Go to step 8.	<p>Repair harness and connector.</p> <p>NOTE:                      In this case, repair the following:</p> <ul style="list-style-type: none"> <li>● Open circuit in harness between ECM and atmospheric pressure sensor connector</li> <li>● Poor contact in joint connector LHD: (B122) RHD: (B83)</li> </ul>
8	<p><b>CHECK HARNESS BETWEEN ECM AND ATMOSPHERIC PRESSURE SENSOR CONNECTOR.</b></p> <p>1) Turn ignition switch to OFF.                      2) Disconnect connector from ECM.                      3) Measure resistance of harness between ECM and pressure sensor connector.</p> <p><b>Connector &amp; terminal</b>  <b>(B136) No. 16 — (B2) No. 1:</b></p>	Is the resistance less than 1 Ω?	Go to step 9.	<p>Repair harness and connector.</p> <p>NOTE:                      In this case, repair the following:</p> <ul style="list-style-type: none"> <li>● Open circuit in harness between ECM and pressure sensor connector</li> </ul>
9	<p><b>CHECK HARNESS BETWEEN ECM AND ATMOSPHERIC PRESSURE SENSOR CONNECTOR.</b></p> <p>Measure resistance of harness between pressure sensor connector and engine ground.</p> <p><b>Connector &amp; terminal</b>  <b>(B2) No. 2 — Engine ground:</b></p>	Is the resistance more than 500 kΩ?	Go to step 10.	<p>Repair ground short circuit in harness between ECM and pressure sensor connector.</p>
10	<p><b>CHECK POOR CONTACT.</b></p> <p>Check poor contact in pressure sensor connector.</p>	Is there poor contact in pressure sensor connector?	Repair poor contact in atmospheric pressure sensor connector.	<p>Replace atmospheric pressure sensor. &lt;Ref. to FU(SOHC)-37, Atmospheric Pressure Sensor .&gt;</p>

**MEMO:**

# DIAGNOSTIC PROCEDURE WITH DIAGNOSTIC TROUBLE CODE (DTC)

Engine (Diagnostics)

## BG: DTC P1111 — ATMOSPHERIC PRESSURE SENSOR CIRCUIT HIGH INPUT — S058521B85

- DTC DETECTING CONDITION:
  - Immediately at fault recognition

### CAUTION:

After repair or replacement of faulty parts, conduct Clear Memory Mode <Ref. to EN(SOHC)-45, OPERATION, Clear Memory Mode.> and Inspection Mode <Ref. to EN(SOHC)-42, OPERATION, Inspection Mode.>.

- WIRING DIAGRAM:

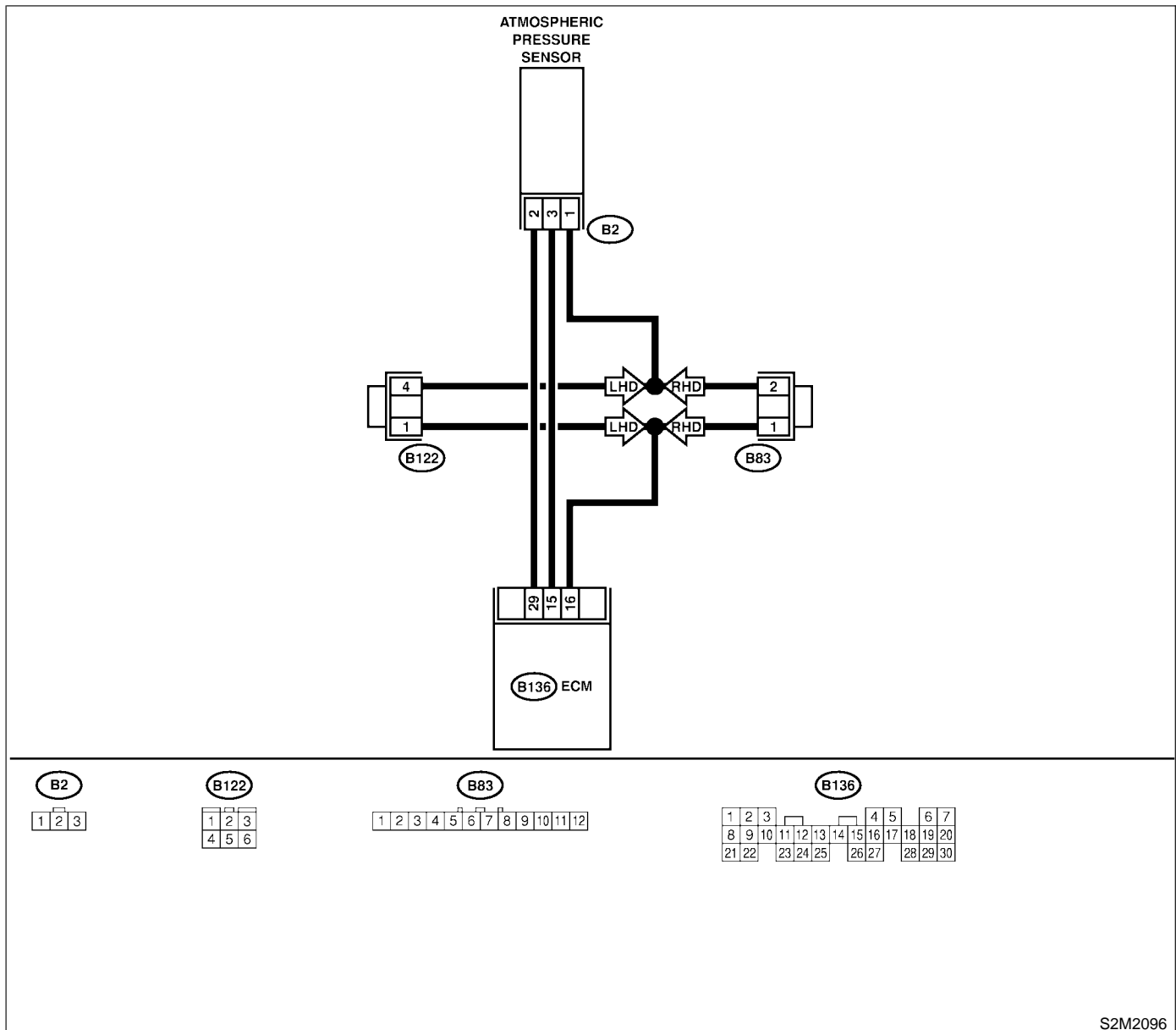

S2M2096



# DIAGNOSTIC PROCEDURE WITH DIAGNOSTIC TROUBLE CODE (DTC)

Engine (Diagnostics)

No.	Step	Check	Yes	No
1	<p><b>CHECK CURRENT DATA.</b>                      1) Start engine.                      2) Read the data of intake manifold absolute pressure signal using Subaru Select Monitor or OBD-II general scan tool.                      NOTE:                      ● Subaru Select Monitor                      For detailed operation procedure, refer to the "READ CURRENT DATA FOR ENGINE".                      &lt;Ref. to EN(SOHC)-34, Subaru Select Monitor.&gt;                      ● OBD-II general scan tool                      For detailed operation procedures, refer to the OBD-II General Scan Tool Instruction Manual.</p>	Is the value more than 140 kPa (1,050 mmHg, 41.34 inHg)?	Go to step 10.	Go to step 2.
2	<p><b>CHECK INPUT SIGNAL FOR ECM.</b>                      Measure voltage between ECM connector and chassis ground.  <b>Connector &amp; terminal</b>  <b>(B136) No. 15 (+) — Chassis ground (-):</b></p>	Is the voltage more than 4.5 V?	Go to step 4.	Go to step 3.
3	<p><b>CHECK INPUT SIGNAL FOR ECM.</b>                      Measure voltage between ECM connector and chassis ground.  <b>Connector &amp; terminal</b>  <b>(B136) No. 15 (+) — Chassis ground (-):</b></p>	Does the voltage change more than 4.5 V by shaking harness and connector of ECM while monitoring the value with voltage meter?	Repair poor contact in ECM connector.	Contact your Subaru distributor. NOTE: Inspection by DTM is required, because probable cause is deterioration of multiple parts.
4	<p><b>CHECK INPUT SIGNAL FOR ECM.</b>                      Measure voltage between ECM connector and chassis ground.  <b>Connector &amp; terminal</b>  <b>(B136) No. 29 (+) — Chassis ground (-):</b></p>	Is the voltage less than 0.2 V?	Go to step 6.	Go to step 5.
5	<p><b>CHECK INPUT SIGNAL FOR ECM. (USING SUBARU SELECT MONITOR.)</b>                      Read data of atmospheric absolute pressure signal using Subaru Select Monitor.                      NOTE:                      ● Subaru Select Monitor                      For detailed operation procedure, refer to the "READ CURRENT DATA FOR ENGINE".                      &lt;Ref. to EN(SOHC)-34, Subaru Select Monitor.&gt;</p>	Does the value change more than 0 kPa (0 mmHg, 0 inHg) by shaking harness and connector of ECM while monitoring the value with Subaru select monitor?	Repair poor contact in ECM connector.	Go to step 6.
6	<p><b>CHECK HARNESS BETWEEN ECM AND PRESSURE SENSOR CONNECTOR.</b>                      1) Turn ignition switch to OFF.                      2) Disconnect connector from atmospheric pressure sensor.                      3) Turn ignition switch to ON.                      4) Measure voltage between atmospheric pressure sensor connector and engine ground.  <b>Connector &amp; terminal</b>  <b>(B2) No. 3 (+) — Engine ground (-):</b></p>	Is the voltage more than 4.5 V?	Go to step 7.	Repair harness and connector. NOTE: In this case, repair the following: ● Open circuit in harness between ECM and pressure sensor connector ● Poor contact in joint connector LHD: B122 RHD: B83

# DIAGNOSTIC PROCEDURE WITH DIAGNOSTIC TROUBLE CODE (DTC)

Engine (Diagnostics)

No.	Step	Check	Yes	No
7	<p><b>CHECK HARNESS BETWEEN ECM AND PRESSURE SENSOR CONNECTOR.</b></p> <p>1) Turn ignition switch to OFF. 2) Disconnect connector from ECM. 3) Measure resistance of harness between ECM and pressure sensor connector.</p> <p><b>Connector &amp; terminal</b> <b>(B136) No. 29 — (B2) No. 2:</b></p>	Is the resistance less than 1 Ω?	Go to step 8.	<p>Repair harness and connector.</p> <p>NOTE: In this case, repair the following:</p> <ul style="list-style-type: none"> <li>● Open circuit in harness between ECM and pressure sensor connector</li> <li>● Poor contact in joint connector LHD: B122 RHD: B83</li> </ul>
8	<p><b>CHECK HARNESS BETWEEN ECM AND PRESSURE SENSOR CONNECTOR.</b></p> <p>Measure resistance of harness between ECM and pressure sensor connector.</p> <p><b>Connector &amp; terminal</b> <b>(B136) No. 16 — (B2) No. 1:</b></p>	Is the resistance less than 1 Ω?	Go to step 9.	<p>Repair harness and connector.</p> <p>NOTE: In this case, repair the following:</p> <ul style="list-style-type: none"> <li>● Open circuit in harness between ECM and pressure sensor connector</li> <li>● Poor contact in joint connector LHD: B122 RHD: B83</li> </ul>
9	<p><b>CHECK POOR CONTACT.</b></p> <p>Check poor contact in pressure sensor connector.</p>	Is there poor contact in pressure sensor connector?	Repair poor contact in atmospheric pressure sensor connector.	Replace atmospheric pressure sensor. <Ref. to FU(SOHC)-37, Atmospheric Pressure Sensor .>
10	<p><b>CHECK CURRENT DATA.</b></p> <p>1) Turn ignition switch to OFF. 2) Disconnect connector from atmospheric pressure sensor. 3) Turn ignition switch to ON. 4) Read data of intake manifold absolute pressure signal using Subaru select monitor or OBD-II general scan tool.</p> <p>NOTE:</p> <ul style="list-style-type: none"> <li>● Subaru Select Monitor For detailed operation procedure, refer to the "READ CURRENT DATA FOR ENGINE". &lt;Ref. to EN(SOHC)-34, Subaru Select Monitor.&gt;</li> <li>● OBD-II general scan tool For detailed operation procedures, refer to the OBD-II General Scan Tool Instruction Manual.</li> </ul>	Is the value more than 140 kPa (1,050 mmHg, 41.34 inHg)?	Repair battery short circuit in harness between ECM and atmospheric pressure sensor connector.	Replace atmospheric pressure sensor. <Ref. to FU(SOHC)-37, Atmospheric Pressure Sensor.>

**MEMO:**

# DIAGNOSTIC PROCEDURE WITH DIAGNOSTIC TROUBLE CODE (DTC)

Engine (Diagnostics)

## BH: DTC P1112 — ATMOSPHERIC PRESSURE SENSOR CIRCUIT RANGE/ PERFORMANCE PROBLEM — S058521B86

- DTC DETECTING CONDITION:
  - Immediately at fault recognition

### CAUTION:

After repair or replacement of faulty parts, conduct Clear Memory Mode <Ref. to EN(SOHC)-45, OPERATION, Clear Memory Mode.> and Inspection Mode <Ref. to EN(SOHC)-42, OPERATION, Inspection Mode.>.

- WIRING DIAGRAM:

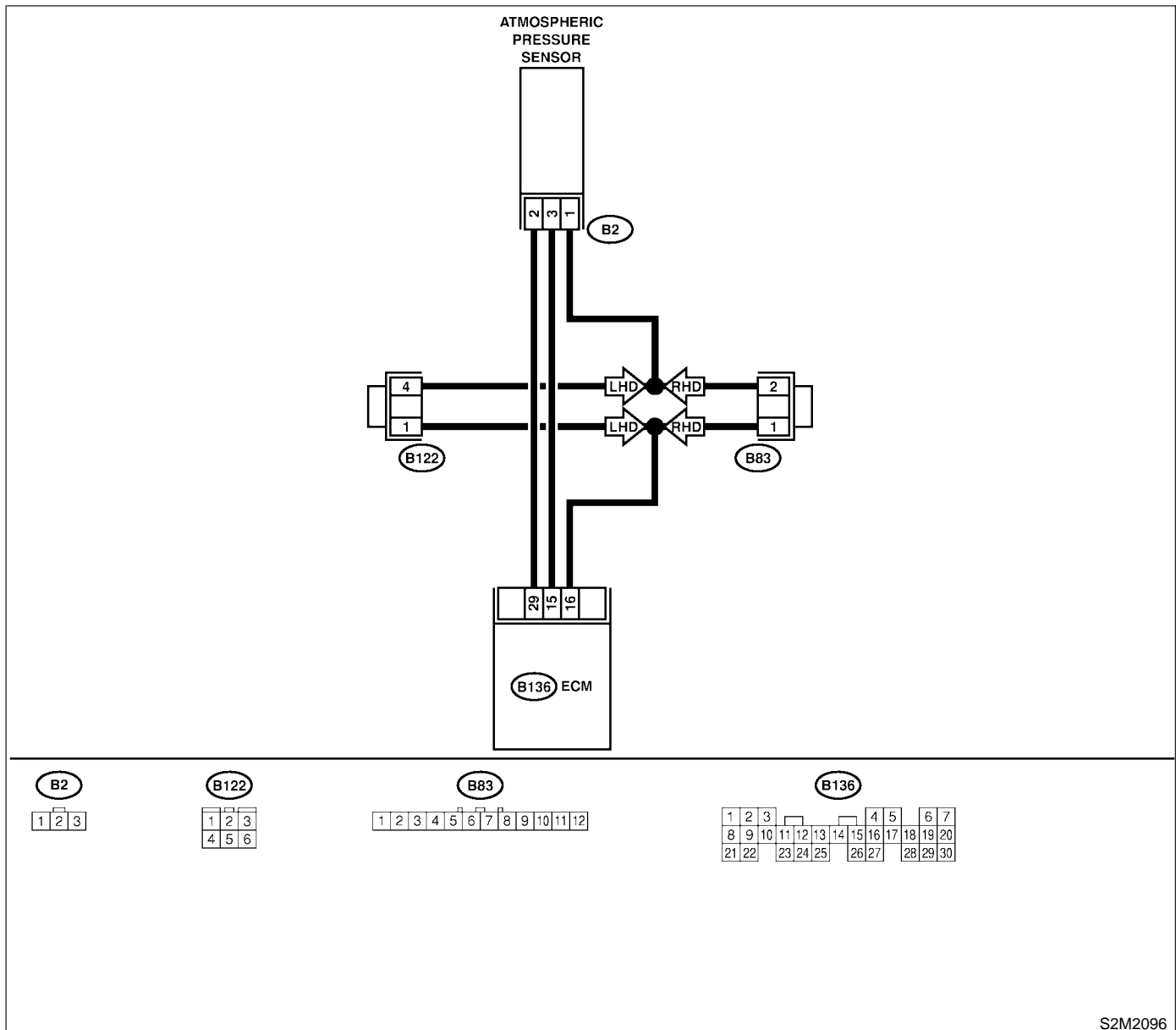

S2M2096

# DIAGNOSTIC PROCEDURE WITH DIAGNOSTIC TROUBLE CODE (DTC)

Engine (Diagnostics)

No.	Step	Check	Yes	No
1	<p><b>CHECK ANY OTHER DTC ON DISPLAY.</b></p> <p>NOTE: In this case, it is not necessary to inspect DTC P0106.</p>	Does the Subaru Select Monitor or OBD-II general scan tool indicate DTC P0106, P0107, P0108, P1110 or P1111?	Inspect DTC P0106, P0107, P0108, P1110 or P1111 using "17. List of Diagnostic Trouble Code (DTC)". <Ref. to EN(SOHC)-80, List of Diagnostic Trouble Code (DTC).>	Go to step 2.
2	<p><b>CHECK ATMOSPHERIC PRESSURE SENSOR FILTER.</b></p> <p>1) Turn ignition switch to OFF. 2) Disconnect connector from atmospheric pressure sensor. 3) Remove atmospheric pressure sensor. 4) Check atmospheric pressure sensor filter.</p>	Is atmospheric pressure sensor filter non-functional? (Check for contamination, damage, water leakage, etc.)	Replace atmospheric pressure sensor filter.	Go to step 3.
3	<p><b>CHECK CURRENT DATA.</b></p> <p>1) Turn ignition switch to ON. 2) Read data of intake manifold absolute pressure signal using Subaru Select Monitor or OBD-II general scan tool.</p> <p>NOTE:</p> <ul style="list-style-type: none"> <li>● Subaru Select Monitor For detailed operation procedure, refer to the "READ CURRENT DATA FOR ENGINE". &lt;Ref. to EN(SOHC)-34, Subaru Select Monitor.&gt;</li> <li>● OBD-II general scan tool For detailed operation procedures, refer to the OBD-II General Scan Tool Instruction Manual.</li> </ul>	Is the value between 73.3 kPa (550 mmHg, 21.65 inHg) and 106.6 kPa (800 mmHg, 31.50 inHg)?	Replace atmospheric pressure sensor. <Ref. to FU(SOHC)-37, Atmospheric Pressure Sensor .>	Replace intake air temperature and pressure sensor. <Ref. to FU(SOHC)-36, Intake Air Temperature and Pressure Sensor.>

# DIAGNOSTIC PROCEDURE WITH DIAGNOSTIC TROUBLE CODE (DTC)

Engine (Diagnostics)

## BI: DTC P1137 — FRONT OXYGEN (A/F) SENSOR CIRCUIT RANGE/PERFORMANCE PROBLEM —

S058521G49

- DTC DETECTING CONDITION:
  - Immediately at fault recognition

### CAUTION:

After repair or replacement of faulty parts, conduct Clear Memory Mode <Ref. to EN(SOHC)-45, OPERATION, Clear Memory Mode.> and Inspection Mode <Ref. to EN(SOHC)-42, OPERATION, Inspection Mode.>.

### ● WIRING DIAGRAM:

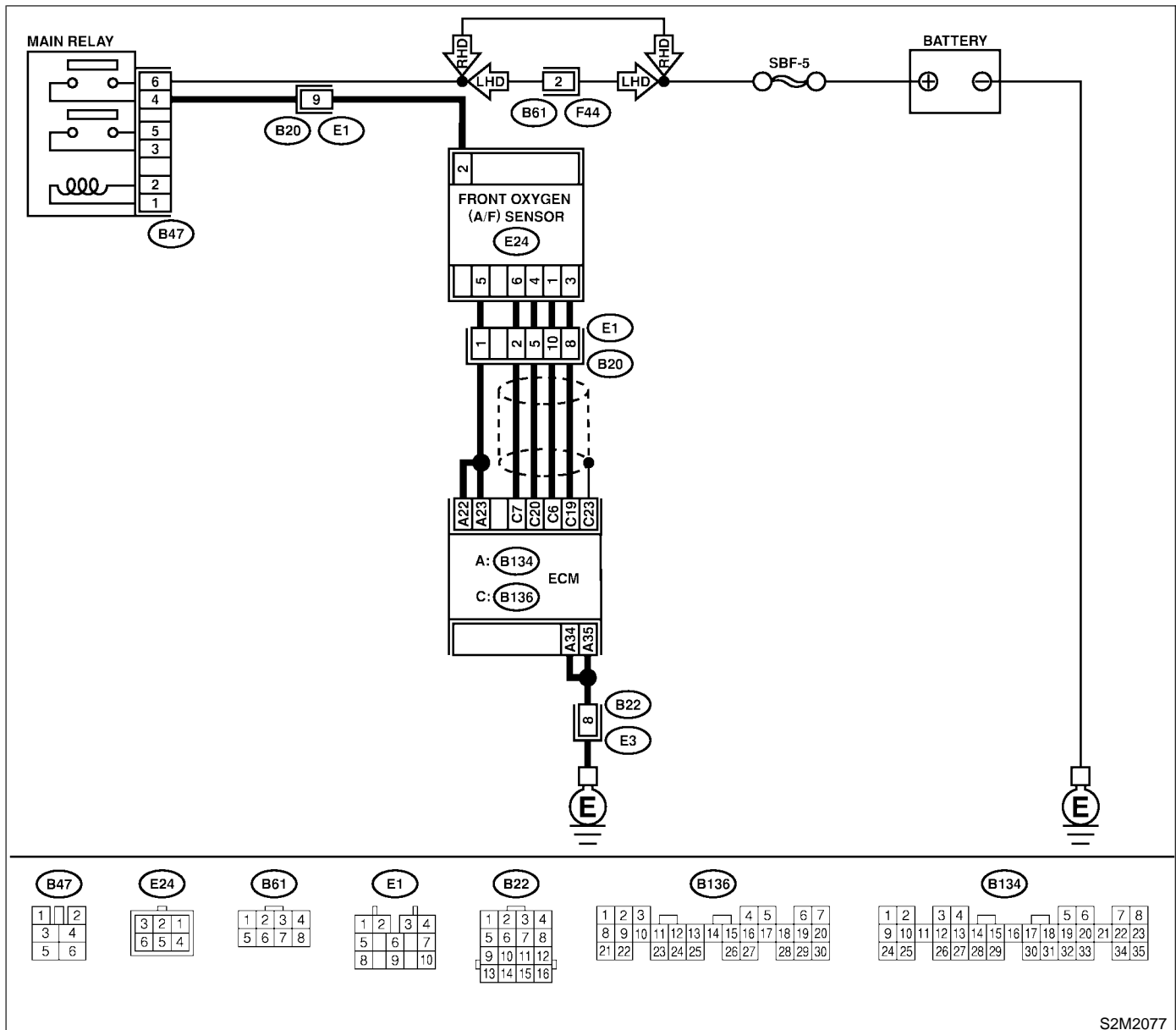

S2M2077

# DIAGNOSTIC PROCEDURE WITH DIAGNOSTIC TROUBLE CODE (DTC)

Engine (Diagnostics)

No.	Step	Check	Yes	No
1	<b>CHECK ANY OTHER DTC ON DISPLAY.</b>	Does the Subaru Select Monitor or OBD-II general scan tool indicate DTC P0131, P0132, P0031 or P0032?	Inspect DTC P0131, P0132, P0031 or P0032 using "17. List of Diagnostic Trouble Code (DTC)". <Ref. to EN(SOHC)-80, List of Diagnostic Trouble Code (DTC).>	Go to step 2.
2	<b>CHECK FRONT OXYGEN (A/F) SENSOR DATA.</b> 1) Start engine. 2) While observing the Subaru Select Monitor or OBD-II general scan tool screen, warm-up the engine until coolant temperature is above 70°C (160°F). If the engine is already warmed-up, operate at idle speed for at least 1 minute. 3) Read data of front oxygen (A/F) sensor signal using Subaru Select Monitor or OBD-II general scan tool. <b>NOTE:</b> ● Subaru Select Monitor For detailed operation procedure, refer to the "READ CURRENT DATA FOR ENGINE". <Ref. to EN(SOHC)-34, Subaru Select Monitor.> ● OBD-II general scan tool For detailed operation procedures, refer to the OBD-II General Scan Tool Instruction Manual.	Is the value equal to or more than 0.85 and equal to less than 1.15 in idling?	Go to step 3.	Go to step 4.
3	<b>CHECK FRONT OXYGEN (A/F) SENSOR DATA.</b> Race engine at speeds from idling to 5,000 rpm for a total of 5 cycles. <b>NOTE:</b> To increase engine speed to 5,000 rpm, slowly depress accelerator pedal, taking approximately 5 seconds, and quickly release accelerator pedal to decrease engine speed.	Is the value more than 1.1 for a moment?	Go to step 6.	Go to step 4.
4	<b>CHECK HARNESS BETWEEN ECM AND FRONT OXYGEN (A/F) SENSOR.</b> 1) Turn ignition switch to OFF. 2) Disconnect connector from ECM and front oxygen (A/F) sensor connector. 3) Measure resistance between ECM and front oxygen (A/F) sensor. <b>Connector &amp; terminals</b> (B136) No. 6 — (E24) No. 1: (B136) No. 7 — (E24) No. 6: (B136) No. 19 — (E24) No. 3: (B136) No. 20 — (E24) No. 4:	Is the resistance less than 5 Ω?	Go to step 5.	Repair open circuit between ECM and front oxygen (A/F) sensor.

# DIAGNOSTIC PROCEDURE WITH DIAGNOSTIC TROUBLE CODE (DTC)

Engine (Diagnostics)

No.	Step	Check	Yes	No
5	<b>CHECK HARNESS BETWEEN ECM AND FRONT OXYGEN (A/F) SENSOR.</b> Measure resistance between ECM and chassis ground. <b>Connector &amp; terminals</b> <i>(B136) No. 6 — Chassis ground:</i> <i>(B136) No. 7 — Chassis ground:</i> <i>(B136) No. 19 — Chassis ground:</i> <i>(B136) No. 20 — Chassis ground:</i>	Is the resistance more than 1 M $\Omega$ ?	Go to step 6.	Repair ground short circuit between ECM and front oxygen (A/F) sensor.
6	<b>CHECK EXHAUST SYSTEM.</b> Check exhaust system parts. NOTE: Check the following items. <ul style="list-style-type: none"><li>● Loose installation of portions</li><li>● Damage (crack, hole etc.) of parts</li><li>● Looseness of front oxygen (A/F) sensor</li><li>● Looseness and ill fitting of parts between front oxygen (A/F) sensor and rear oxygen sensor</li></ul>	Is there a fault in exhaust system?	Repair or replace faulty parts.	Replace front oxygen (A/F) sensor. <Ref. to FU(SOHC)-45, Front Oxygen (A/F) Sensor.>



**MEMO:**

# DIAGNOSTIC PROCEDURE WITH DIAGNOSTIC TROUBLE CODE (DTC)

Engine (Diagnostics)

## BJ: DTC P1142 — THROTTLE POSITION SENSOR CIRCUIT RANGE/PERFORMANCE PROBLEM (LOW INPUT) — S058521B99

### ● DTC DETECTING CONDITION:

- Two consecutive driving cycles with fault

### ● TROUBLE SYMPTOM:

- Erroneous idling
- Engine stalls.
- Poor driving performance

### CAUTION:

After repair or replacement of faulty parts, conduct Clear Memory Mode <Ref. to EN(SOHC)-45, OPERATION, Clear Memory Mode.> and Inspection Mode <Ref. to EN(SOHC)-42, OPERATION, Inspection Mode.>.

### ● WIRING DIAGRAM:

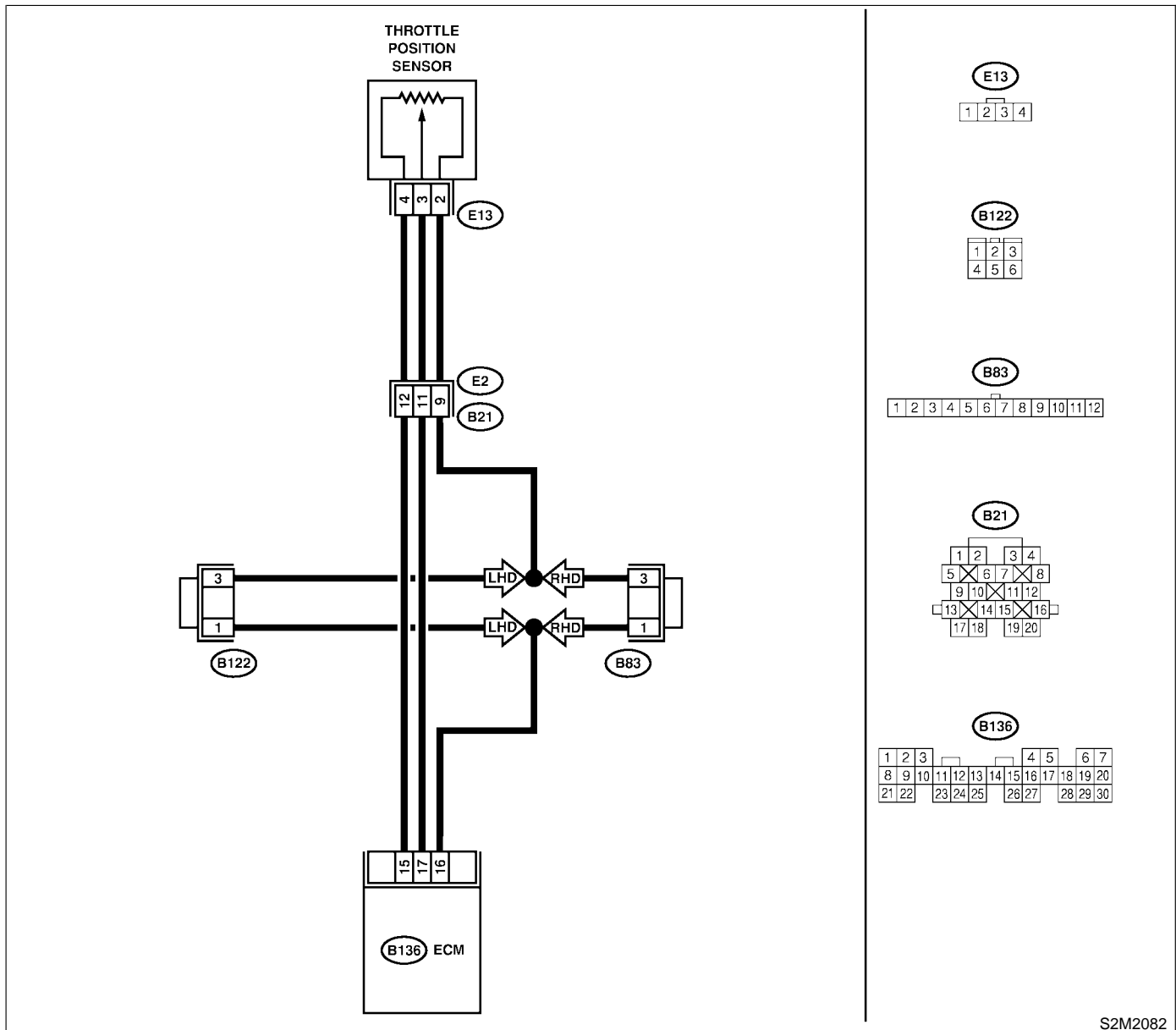

# DIAGNOSTIC PROCEDURE WITH DIAGNOSTIC TROUBLE CODE (DTC)

Engine (Diagnostics)

No.	Step	Check	Yes	No
1	CHECK ANY OTHER DTC ON DISPLAY.	Does the Subaru Select Monitor or OBD-II general scan tool indicate DTC P0122 or P0123?	Inspect DTC P0122 or P0123 using "17. List of Diagnostic Trouble Code (DTC)". <Ref. to EN(SOHC)-80, List of Diagnostic Trouble Code (DTC).> NOTE: In this case, it is not necessary to inspect DTC P1142.	Replace throttle position sensor. <Ref. to FU(SOHC)-33 Throttle Position Sensor.>

# DIAGNOSTIC PROCEDURE WITH DIAGNOSTIC TROUBLE CODE (DTC)

Engine (Diagnostics)

## BK: DTC P1146 — PRESSURE SENSOR CIRCUIT RANGE/PERFORMANCE PROBLEM (HIGH INPUT) — S058521G07

- DTC DETECTING CONDITION:
  - Two consecutive driving cycles with fault

### CAUTION:

After repair or replacement of faulty parts, conduct Clear Memory Mode <Ref. to EN(SOHC)-45, OPERATION, Clear Memory Mode.> and Inspection Mode <Ref. to EN(SOHC)-42, OPERATION, Inspection Mode.>.

### ● WIRING DIAGRAM:

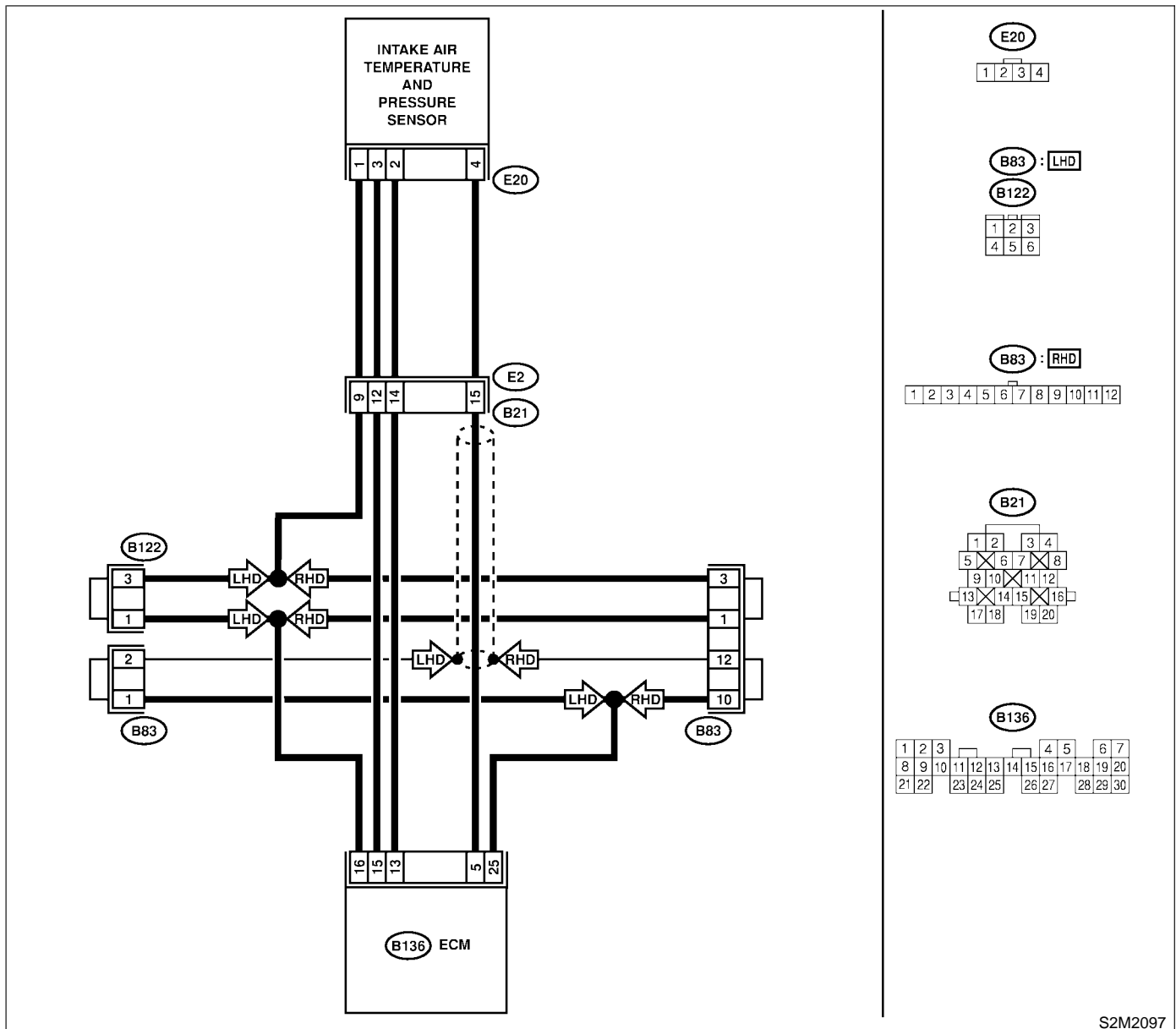

S2M2097

# DIAGNOSTIC PROCEDURE WITH DIAGNOSTIC TROUBLE CODE (DTC)

Engine (Diagnostics)

No.	Step	Check	Yes	No
1	<p><b>CHECK ANY OTHER DTC ON DISPLAY.</b></p> <p>NOTE: In this case, it is not necessary to inspect DTC P0106.</p>	Does the Subaru Select Monitor or OBD-II general scan tool indicate DTC P0107, P0108 or P1112?	Inspect DTC P0107, P0108 or P1112 using "17. List of Diagnostic Trouble Code (DTC)". <Ref. to EN(SOHC)-80, List of Diagnostic Trouble Code (DTC).>	Go to step 2.
2	<p><b>CHECK AIR INTAKE SYSTEM.</b></p>	Are there holes, loose bolts or disconnection of hose on air intake system?	Repair air intake system.	Go to step 3.
3	<p><b>CHECK PRESSURE SENSOR.</b></p> <p>1) Start the engine and warm-up engine until coolant temperature is greater than 60°C (140°F). 2) Place the shift lever in the selector lever in "N" or "P" position. 3) Turn A/C switch to OFF. 4) Turn all accessory switches to OFF. 5) Read data of intake manifold pressure sensor signal using Subaru Select Monitor or OBD-II general scan tool.</p> <p>NOTE:</p> <ul style="list-style-type: none"> <li>● Subaru Select Monitor For detailed operation procedure, refer to the "READ CURRENT DATA FOR ENGINE". &lt;Ref. to EN(SOHC)-34, Subaru Select Monitor.&gt;</li> <li>● OBD-II general scan tool For detailed operation procedure, refer to the OBD-II General Scan Tool Instruction Manual.</li> </ul> <p>Specification:</p> <ul style="list-style-type: none"> <li>● Intake manifold absolute pressure</li> </ul> <p><b>Ignition ON</b> 73.3 — 106.6 kPa (550 — 800 mmHg, 21.65 — 31.50 inHg)</p> <p><b>Idling</b> 20.0 — 46.7 kPa (150 — 350 mmHg, 5.91 — 13.78 inHg)</p>	Is the value within the specifications?	Go to step 4.	Replace intake air temperature sensor and pressure sensor. <Ref. to FU(SOHC)-36, Intake Air Temperature and Pressure Sensor.>
4	<p><b>CHECK THROTTLE POSITION.</b></p> <p>Read data of throttle position signal using Subaru Select Monitor or OBD-II general scan tool.</p> <p>NOTE:</p> <ul style="list-style-type: none"> <li>● Subaru Select Monitor For detailed operation procedure, refer to the "READ CURRENT DATA FOR ENGINE". &lt;Ref. to EN(SOHC)-34, Subaru Select Monitor.&gt;</li> <li>● OBD-II general scan tool For detailed operation procedure, refer to the OBD-II General Scan Tool Instruction Manual.</li> </ul>	Is throttle positioning ratio equal to or less than 5% when throttle is fully closed?	Go to step 5.	Adjust or replace throttle position sensor. <Ref. to FU(SOHC)-33, Throttle Position Sensor.>

# DIAGNOSTIC PROCEDURE WITH DIAGNOSTIC TROUBLE CODE (DTC)

Engine (Diagnostics)

No.	Step	Check	Yes	No
5	CHECK THROTTLE POSITION.	Is throttle positioning ratio equal to or more than 85% when throttle is fully open?	Replace intake air temperature and pressure sensor. <Ref. to FU(SOHC)-36, Intake Air Temperature and Pressure Sensor.>	Replace throttle position sensor. <Ref. to FU(SOHC)-33, Throttle Position Sensor.>

**DIAGNOSTIC PROCEDURE WITH DIAGNOSTIC TROUBLE CODE (DTC)**  
Engine (Diagnostics)

---

**MEMO:**

# DIAGNOSTIC PROCEDURE WITH DIAGNOSTIC TROUBLE CODE (DTC)

Engine (Diagnostics)

## BL: DTC P1442 — FUEL LEVEL SENSOR CIRCUIT RANGE/PERFORMANCE PROBLEM 2 —

S058521C11

### ● DTC DETECTING CONDITION:

- Two consecutive driving cycles with fault

### CAUTION:

After repair or replacement of faulty parts, conduct Clear Memory Mode <Ref. to EN(SOHC)-45, OPERATION, Clear Memory Mode.> and Inspection Mode <Ref. to EN(SOHC)-42, OPERATION, Inspection Mode.>.

### ● WIRING DIAGRAM:

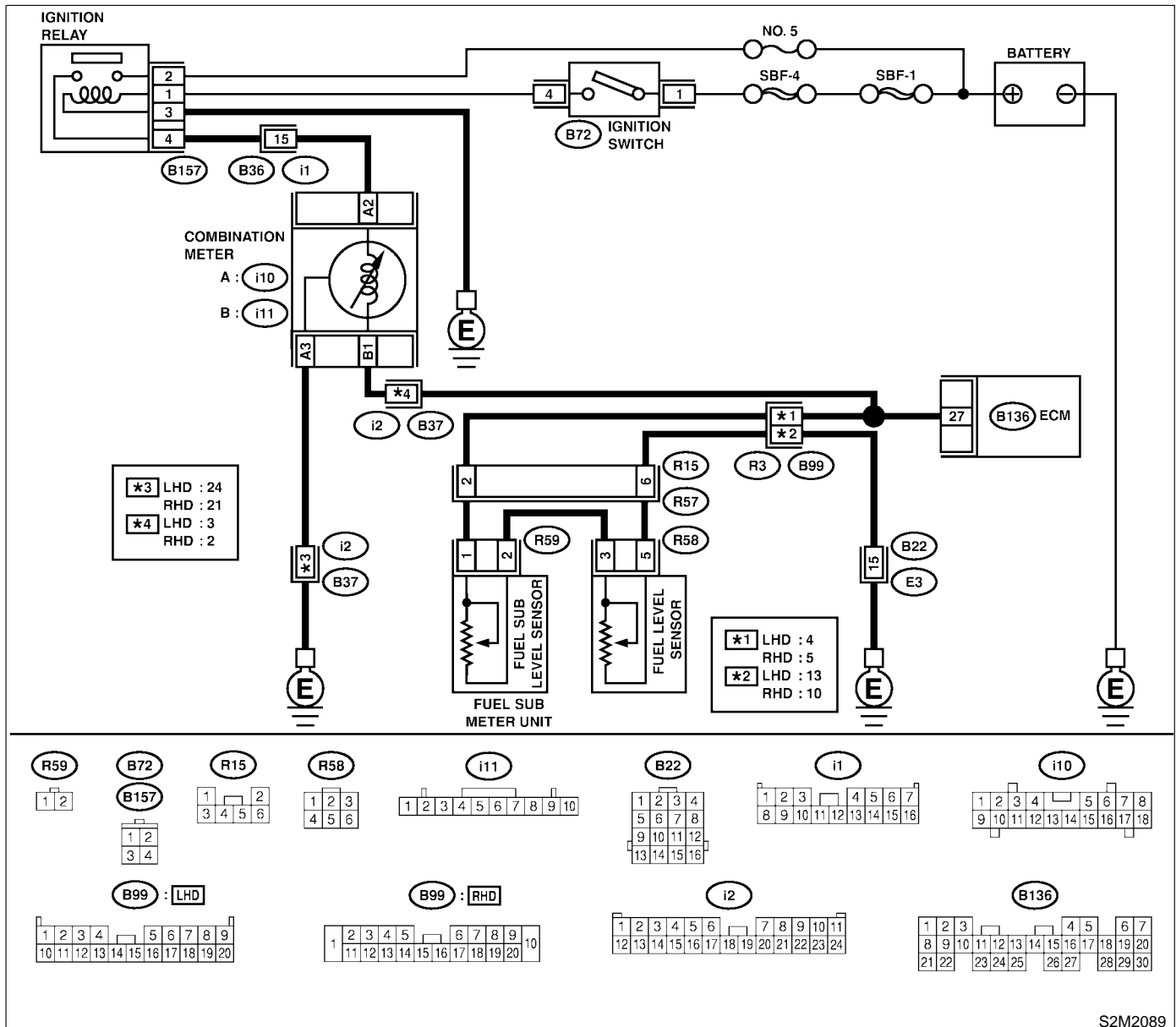

S2M2089



# DIAGNOSTIC PROCEDURE WITH DIAGNOSTIC TROUBLE CODE (DTC)

Engine (Diagnostics)

No.	Step	Check	Yes	No
1	CHECK ANY OTHER DTC ON DISPLAY.	Does the Subaru Select Monitor or OBD-II general scan tool indicate DTC P0461, P0462 or P0463?	Inspect DTC P0461, P0462 or P0463 using "17. List of Diagnostic Trouble Code (DTC)". <Ref. to EN(SOHC)-80, List of Diagnostic Trouble Code (DTC).> NOTE: In this case, it is not necessary to inspect this trouble.	Replace fuel level sensor <Ref. to FU(SOHC)-64, Fuel Level Sensor.> and fuel sub level sensor. <Ref. to FU(SOHC)-65, Fuel Sub Level Sensor.>

# DIAGNOSTIC PROCEDURE WITH DIAGNOSTIC TROUBLE CODE (DTC)

Engine (Diagnostics)

---

## **BM: DTC P1480 — COOLING FAN RELAY 1 CIRCUIT HIGH INPUT —** S058521G08

- **DTC DETECTING CONDITION:**
  - Two consecutive driving cycles with fault
- **TROUBLE SYMPTOM:**
  - Radiator fan does not operate properly.
  - Overheating

### **CAUTION:**

After repair or replacement of faulty parts, conduct Clear Memory Mode <Ref. to EN(SOHC)-45, OPERATION, Clear Memory Mode.> and Inspection Mode <Ref. to EN(SOHC)-42, OPERATION, Inspection Mode.>.

# DIAGNOSTIC PROCEDURE WITH DIAGNOSTIC TROUBLE CODE (DTC)

Engine (Diagnostics)

● **WIRING DIAGRAM:**

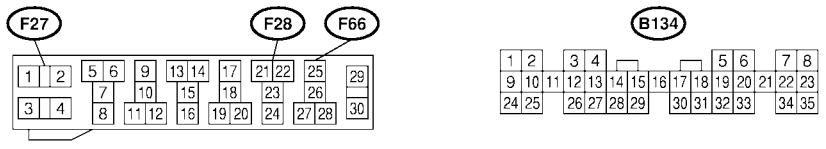
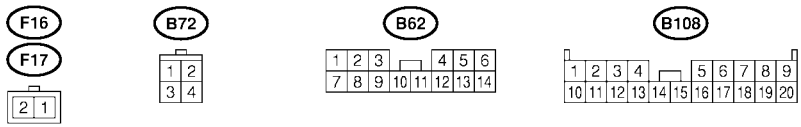
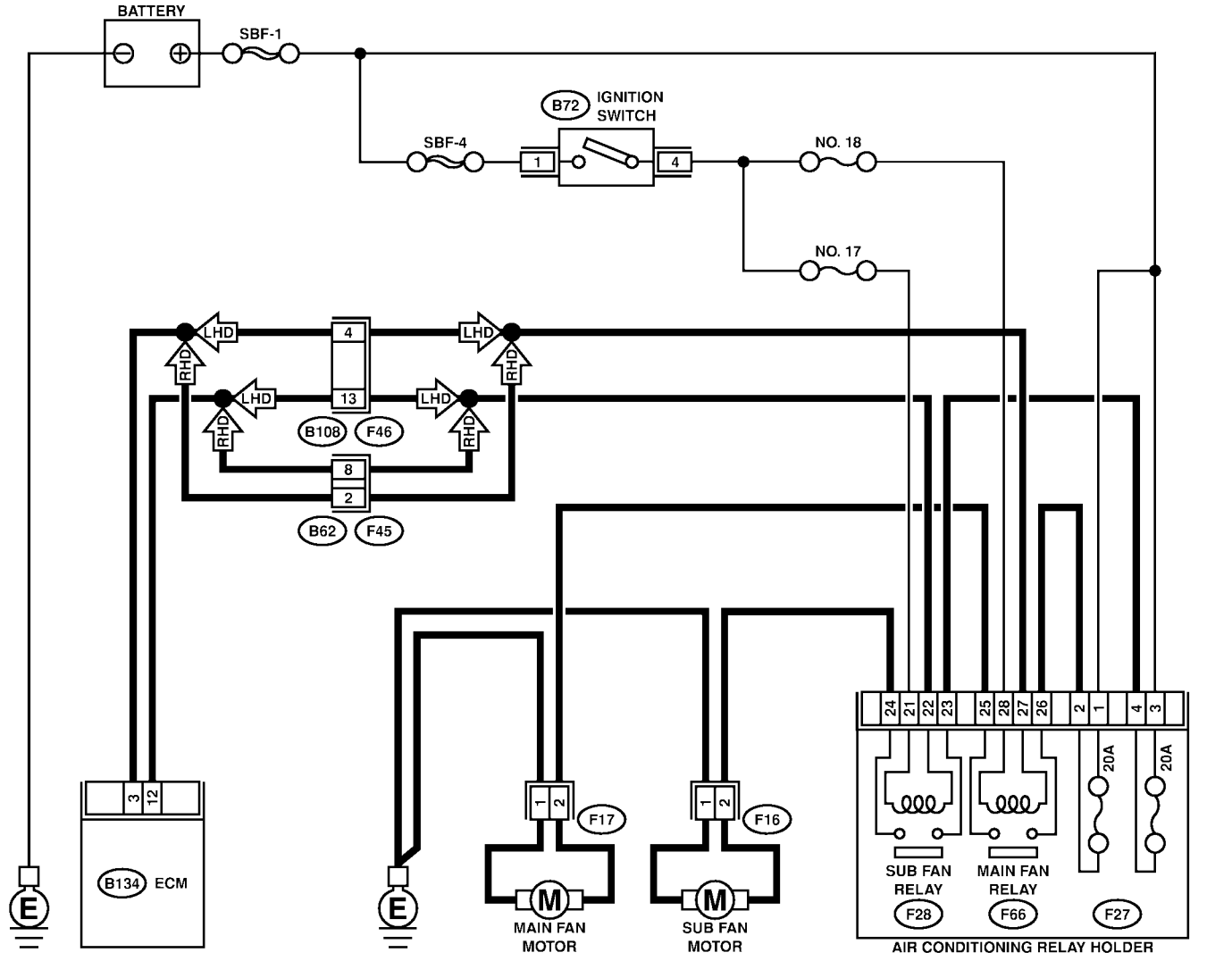

S2M2090

# DIAGNOSTIC PROCEDURE WITH DIAGNOSTIC TROUBLE CODE (DTC)

Engine (Diagnostics)

No.	Step	Check	Yes	No
1	<p><b>CHECK OUTPUT SIGNAL FROM ECM.</b></p> <p>1) Turn ignition switch to OFF.                      2) Connect test mode connector at the lower portion of instrument panel (on the driver's side), to the side of the center console box.                      3) Turn ignition switch to ON.                      4) While operating radiator fan relay, measure voltage between ECM and chassis ground.</p> <p>NOTE:                      Radiator fan relay operation can be executed using Subaru Select Monitor. For procedure, refer to "Compulsory Valve Operation Check Mode". &lt;Ref. to EN(SOHC)-46, Compulsory Valve Operation Check Mode.&gt;</p> <p><b>Connector &amp; terminal</b>  <b>(B134) No. 3 (+) — Chassis ground (-):</b></p>	Does voltage change between 0 and 10 V?	Even if MIL lights up, the circuit has returned to a normal condition at this time. In this case, repair poor contact in ECM connector.	Go to step 2.
2	<p><b>CHECK SHORT CIRCUIT IN RADIATOR FAN RELAY CONTROL CIRCUIT.</b></p> <p>1) Turn ignition switch to OFF.                      2) Remove main fan relay and sub fan relay. (with A/C models)                      3) Disconnect test mode connector.                      4) Turn ignition switch to ON.                      5) Measure voltage between ECM and chassis ground.</p> <p><b>Connector &amp; terminal</b>  <b>(B134) No. 3 (+) — Chassis ground (-):</b></p>	Is the voltage more than 10 V?	Repair battery short circuit in radiator fan relay control circuit. After repair, replace ECM. <Ref. to FU(SOHC)-49,, Engine Control Module.>	Go to step 3.
3	<p><b>CHECK MAIN FAN RELAY.</b></p> <p>1) Turn ignition switch to OFF.                      2) Remove main fan relay.                      3) Measure resistance between main fan relay terminals.</p> <p><b>Terminal</b>  <b>No. 25 — No. 26:</b></p>	Is the resistance less than 1 $\Omega$ ?	Replace main fan relay and ECM. <Ref. to FU(SOHC)-49, Engine Control Module.>	Go to step 4.
4	<p><b>CHECK SUB FAN RELAY.</b></p> <p>1) Remove sub fan relay.                      2) Measure resistance between sub fan relay terminals.</p> <p><b>Terminal</b>  <b>No. 23 — No. 24</b></p>	Is the resistance less than 1 $\Omega$ ?	Replace sub fan relay and ECM. <Ref. to FU(SOHC)-49, Engine Control Module.>	Go to step 5.
5	<p><b>CHECK POOR CONTACT.</b></p> <p>Check poor contact in ECM connector.</p>	Is there poor contact in ECM connector?	Repair poor contact in ECM connector.	Replace ECM. <Ref. to FU(SOHC)-49, Engine Control Module.>

**MEMO:**

# DIAGNOSTIC PROCEDURE WITH DIAGNOSTIC TROUBLE CODE (DTC)

Engine (Diagnostics)

## BN: DTC P1507 — IDLE CONTROL SYSTEM MALFUNCTION (FAIL-SAFE) —

S058521C16

### • DTC DETECTING CONDITION:

- Two consecutive driving cycles with fault

### • TROUBLE SYMPTOM:

- Engine keeps running at higher revolution than specified idling revolution.

### CAUTION:

After repair or replacement of faulty parts, conduct Clear Memory Mode <Ref. to EN(SOHC)-45, OPERATION, Clear Memory Mode.> and Inspection Mode <Ref. to EN(SOHC)-42, OPERATION, Inspection Mode.>.

### • WIRING DIAGRAM:

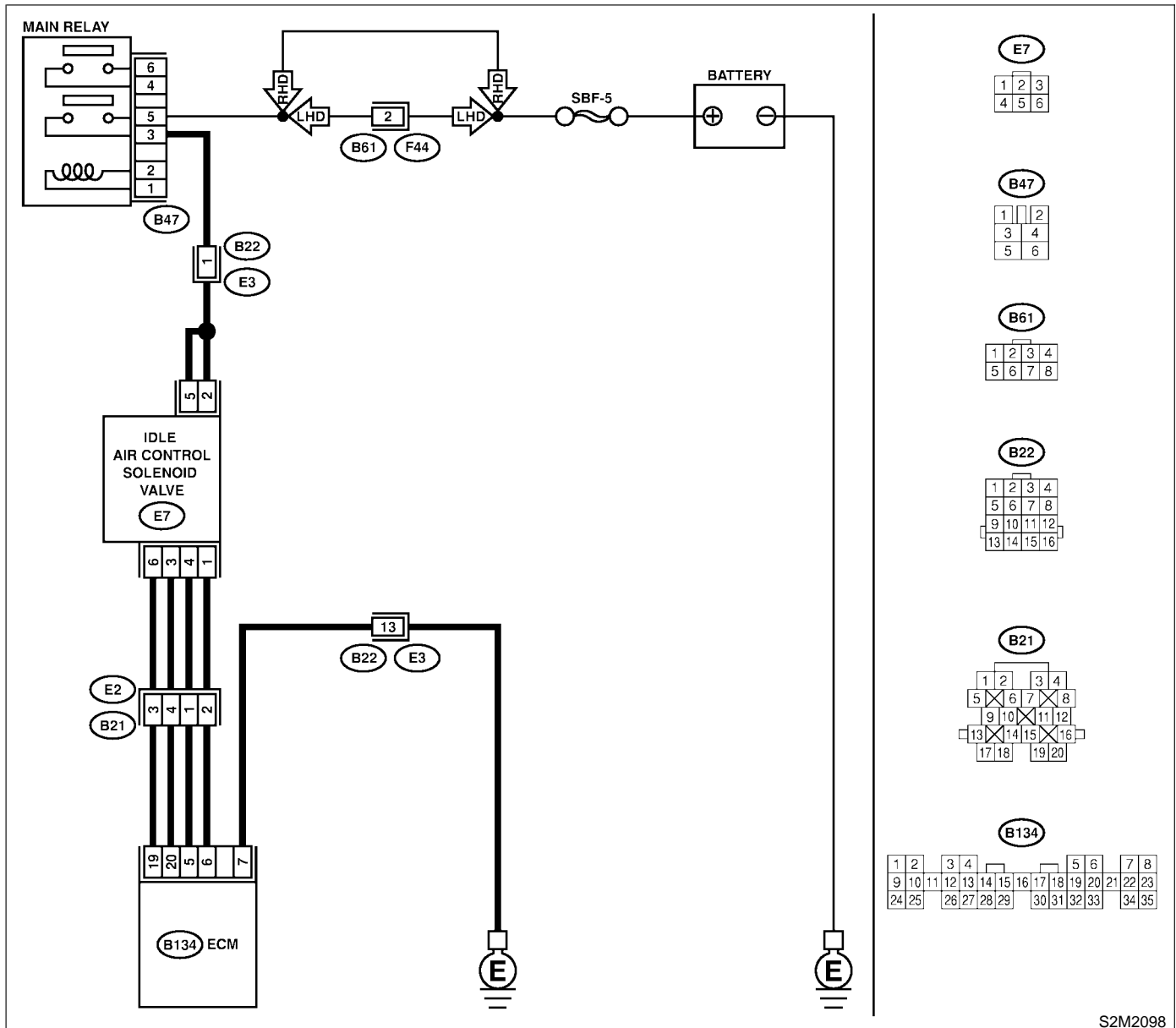

S2M2098

# DIAGNOSTIC PROCEDURE WITH DIAGNOSTIC TROUBLE CODE (DTC)

Engine (Diagnostics)

No.	Step	Check	Yes	No
1	<b>CHECK ANY OTHER DTC ON DISPLAY.</b>	Does the Subaru Select Monitor or OBD-II general scan tool indicate DTC P1510, P1511, P1512, P1513, P1514, P1515, P1516 or P1517?	Inspect DTC P1510, P1511, P1512, P1513, P1514, P1515, P1516 or P1517 using "17. List of Diagnostic Trouble Code (DTC)". <Ref. to EN(SOHC)-80, List of Diagnostic Trouble Code (DTC).> NOTE: In this case, it is not necessary to inspect DTC P0507.	Go to step 2.
2	<b>CHECK AIR INTAKE SYSTEM.</b> 1) Turn ignition switch to ON. 2) Start engine, and idle it. 3) Check the following items. ● Loose installation of intake manifold, idle air control solenoid valve and throttle body ● Cracks of intake manifold gasket, idle air control solenoid valve gasket and throttle body gasket ● Disconnections of vacuum hoses	Is there a fault in air intake system?	Repair air suction and leaks.	Go to step 3.
3	<b>CHECK THROTTLE CABLE.</b>	Does throttle cable have play for adjustment?	Go to step 4.	Adjust throttle cable. <Ref. to SP-12, INSTALLATION, Accelerator Control Cable.>
4	<b>CHECK AIR BY-PASS LINE.</b> 1) Turn ignition switch to OFF. 2) Remove idle air control solenoid valve from throttle body. <Ref. to FU(SOHC)-38, Idle Air Control Solenoid Valve.> 3) Confirm that there are no foreign particles in by-pass air line.	Are foreign particles in by-pass air line?	Remove foreign particles from by-pass air line.	Replace idle air control solenoid valve. <Ref. to FU(SOHC)-38, Idle Air Control Solenoid Valve.>

# DIAGNOSTIC PROCEDURE WITH DIAGNOSTIC TROUBLE CODE (DTC)

Engine (Diagnostics)

---

## **BO: DTC P1510 — IDLE AIR CONTROL SOLENOID VALVE SIGNAL 1 CIRCUIT LOW INPUT —**

*S058521C17*

### NOTE:

For the diagnostic procedure, refer to DTC P1516. <Ref. to EN(SOHC)-258, DTC 1516 — IDLE AIR CONTROL SOLENOID VALVE SIGNAL 4 CIRCUIT LOW INPUT —, Diagnostic Procedure with Diagnostic Trouble Code (DTC).>

## **BP: DTC P1511 — IDLE AIR CONTROL SOLENOID VALVE SIGNAL 1 CIRCUIT HIGH INPUT —**

*S058521C18*

### NOTE:

For the diagnostic procedure, refer to DTC P1517. <Ref. to EN(SOHC)-262, DTC 1517 — IDLE AIR CONTROL SOLENOID VALVE SIGNAL 4 CIRCUIT HIGH INPUT —, Diagnostic Procedure with Diagnostic Trouble Code (DTC).>

## **BQ: DTC P1512 — IDLE AIR CONTROL SOLENOID VALVE SIGNAL 2 CIRCUIT LOW INPUT —**

*S058521C19*

### NOTE:

For the diagnostic procedure, refer to DTC P1516. <Ref. to EN(SOHC)-258, DTC 1516 — IDLE AIR CONTROL SOLENOID VALVE SIGNAL 4 CIRCUIT LOW INPUT —, Diagnostic Procedure with Diagnostic Trouble Code (DTC).>

## **BR: DTC P1513 — IDLE AIR CONTROL SOLENOID VALVE SIGNAL 2 CIRCUIT HIGH INPUT —**

*S058521C20*

### NOTE:

For the diagnostic procedure, refer to DTC P1517. <Ref. to EN(SOHC)-262, DTC 1517 — IDLE AIR CONTROL SOLENOID VALVE SIGNAL 4 CIRCUIT HIGH INPUT —, Diagnostic Procedure with Diagnostic Trouble Code (DTC).>

## **BS: DTC P1514 — IDLE AIR CONTROL SOLENOID VALVE SIGNAL 3 CIRCUIT LOW INPUT —**

*S058521C21*

### NOTE:

For the diagnostic procedure, refer to DTC P1516. <Ref. to EN(SOHC)-258, DTC 1516 — IDLE AIR CONTROL SOLENOID VALVE SIGNAL 4 CIRCUIT LOW INPUT —, Diagnostic Procedure with Diagnostic Trouble Code (DTC).>

## **BT: DTC P1515 — IDLE AIR CONTROL SOLENOID VALVE SIGNAL 3 CIRCUIT HIGH INPUT —**

*S058521C22*

### NOTE:

For the diagnostic procedure, refer to DTC P1517. <Ref. to EN(SOHC)-262, DTC 1517 — IDLE AIR CONTROL SOLENOID VALVE SIGNAL 4 CIRCUIT HIGH INPUT —, Diagnostic Procedure with Diagnostic Trouble Code (DTC).>



**DIAGNOSTIC PROCEDURE WITH DIAGNOSTIC TROUBLE CODE (DTC)**  
Engine (Diagnostics)

---

**MEMO:**

# DIAGNOSTIC PROCEDURE WITH DIAGNOSTIC TROUBLE CODE (DTC)

Engine (Diagnostics)

## BU: DTC P1516 — IDLE AIR CONTROL SOLENOID VALVE SIGNAL 4 CIRCUIT LOW INPUT —

S058521C23

- **DTC DETECTING CONDITION:**
  - Immediately at fault recognition
- **TROUBLE SYMPTOM:**
  - Erroneous idling
  - Engine stalls.
  - Engine breathing

**CAUTION:**

After repair or replacement of faulty parts, conduct Clear Memory Mode <Ref. to EN(SOHC)-45, OPERATION, Clear Memory Mode.> and Inspection Mode <Ref. to EN(SOHC)-42, OPERATION, Inspection Mode.>.

● **WIRING DIAGRAM:**

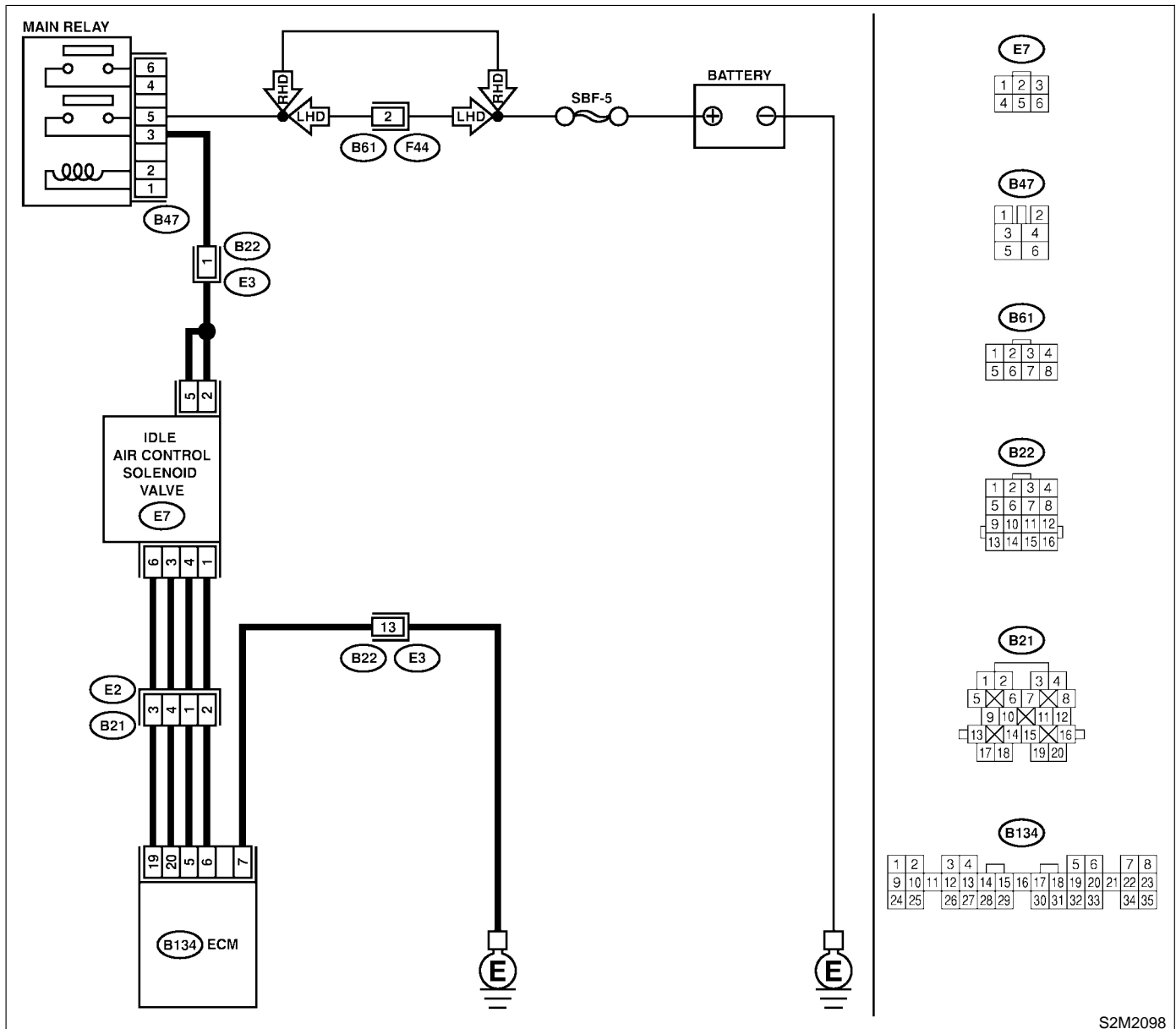

S2M2098

# DIAGNOSTIC PROCEDURE WITH DIAGNOSTIC TROUBLE CODE (DTC)

Engine (Diagnostics)

No.	Step	Check	Yes	No
1	<p><b>CHECK POWER SUPPLY TO IDLE AIR CONTROL SOLENOID VALVE.</b></p> <p>1) Turn ignition switch to OFF.                      2) Disconnect connector from idle air control solenoid valve.                      3) Turn ignition switch to ON.                      4) Measure voltage between idle air control solenoid valve connector and engine ground.</p> <p><b>Connector &amp; terminal</b>  <b>(E7) No. 2 (+) — Engine ground (-):</b></p>	Is the voltage more than 10 V?	Go to step 2.	Repair harness and connector. NOTE: In this case, repair the following: ● Open circuit in harness between idle air control solenoid valve and main relay connector ● Poor contact in coupling connector (B22)
2	<p><b>CHECK POWER SUPPLY TO IDLE AIR CONTROL SOLENOID VALVE.</b></p> <p>Measure voltage between idle air control solenoid valve connector and engine ground.</p> <p><b>Connector &amp; terminal</b>  <b>(E7) No. 5 (+) — Engine ground (-):</b></p>	Is the voltage more than 10 V?	Go to step 3.	Repair harness and connector. NOTE: In this case, repair the following: ● Open circuit in harness between idle air control solenoid valve and main relay connector ● Poor contact in coupling connector (B22)
3	<p><b>CHECK HARNESS BETWEEN ECM AND IDLE AIR CONTROL SOLENOID VALVE CONNECTOR.</b></p> <p>1) Turn ignition switch to OFF.                      2) Measure resistance between ECM and idle air control solenoid valve connector.</p> <p><b>Connector &amp; terminal</b>  <b>DTC P1510; (B134) No. 5 — (E7) No. 4:</b>  <b>DTC P1512; (B134) No. 6 — (E7) No. 1:</b>  <b>DTC P1514; (B134) No. 19 — (E7) No. 6:</b>  <b>DTC P1516; (B134) No. 20 — (E7) No. 3:</b></p>	Is the resistance less than 1 Ω?	Go to step 4.	Repair harness and connector. NOTE: In this case, repair the following: ● Open circuit in harness between ECM and idle air control solenoid valve connector ● Poor contact in coupling connector (B21)
4	<p><b>CHECK HARNESS BETWEEN ECM AND IDLE AIR CONTROL SOLENOID VALVE CONNECTOR.</b></p> <p>1) Disconnect connector from ECM.                      2) Measure resistance between ECM connector and chassis ground.</p> <p><b>Connector &amp; terminal</b>  <b>DTC P1510; (B134) No. 5 — Chassis ground:</b>  <b>DTC P1512; (B134) No. 6 — Chassis ground:</b>  <b>DTC P1514; (B134) No. 19 — Chassis ground:</b>  <b>DTC P1516; (B134) No. 20 — Chassis ground:</b></p>	Is the resistance less than 10 Ω?	Repair ground short circuit in harness between ECM and idle air control solenoid valve connector.	Go to step 5.

# DIAGNOSTIC PROCEDURE WITH DIAGNOSTIC TROUBLE CODE (DTC)

Engine (Diagnostics)

No.	Step	Check	Yes	No
5	<b>CHECK POOR CONTACT.</b> Check poor contact in ECM connector and idle air control solenoid valve connector.	Is there poor contact in ECM connector or idle air control solenoid valve connector?	Repair poor contact in ECM connector or idle air control solenoid valve connector.	Replace idle air control solenoid valve. <Ref. to FU(SOHC)-38, Idle Air Control Solenoid Valve.>

**MEMO:**

# DIAGNOSTIC PROCEDURE WITH DIAGNOSTIC TROUBLE CODE (DTC)

Engine (Diagnostics)

## BV: DTC P1517 — IDLE AIR CONTROL SOLENOID VALVE SIGNAL 4 CIRCUIT HIGH INPUT — S058521C24

- **DTC DETECTING CONDITION:**
  - Immediately at fault recognition
- **TROUBLE SYMPTOM:**
  - Erroneous idling
  - Engine stalls.
  - Engine breathing

**CAUTION:**

After repair or replacement of faulty parts, conduct Clear Memory Mode <Ref. to EN(SOHC)-45, OPERATION, Clear Memory Mode.> and Inspection Mode <Ref. to EN(SOHC)-42, OPERATION, Inspection Mode.>.

● **WIRING DIAGRAM:**

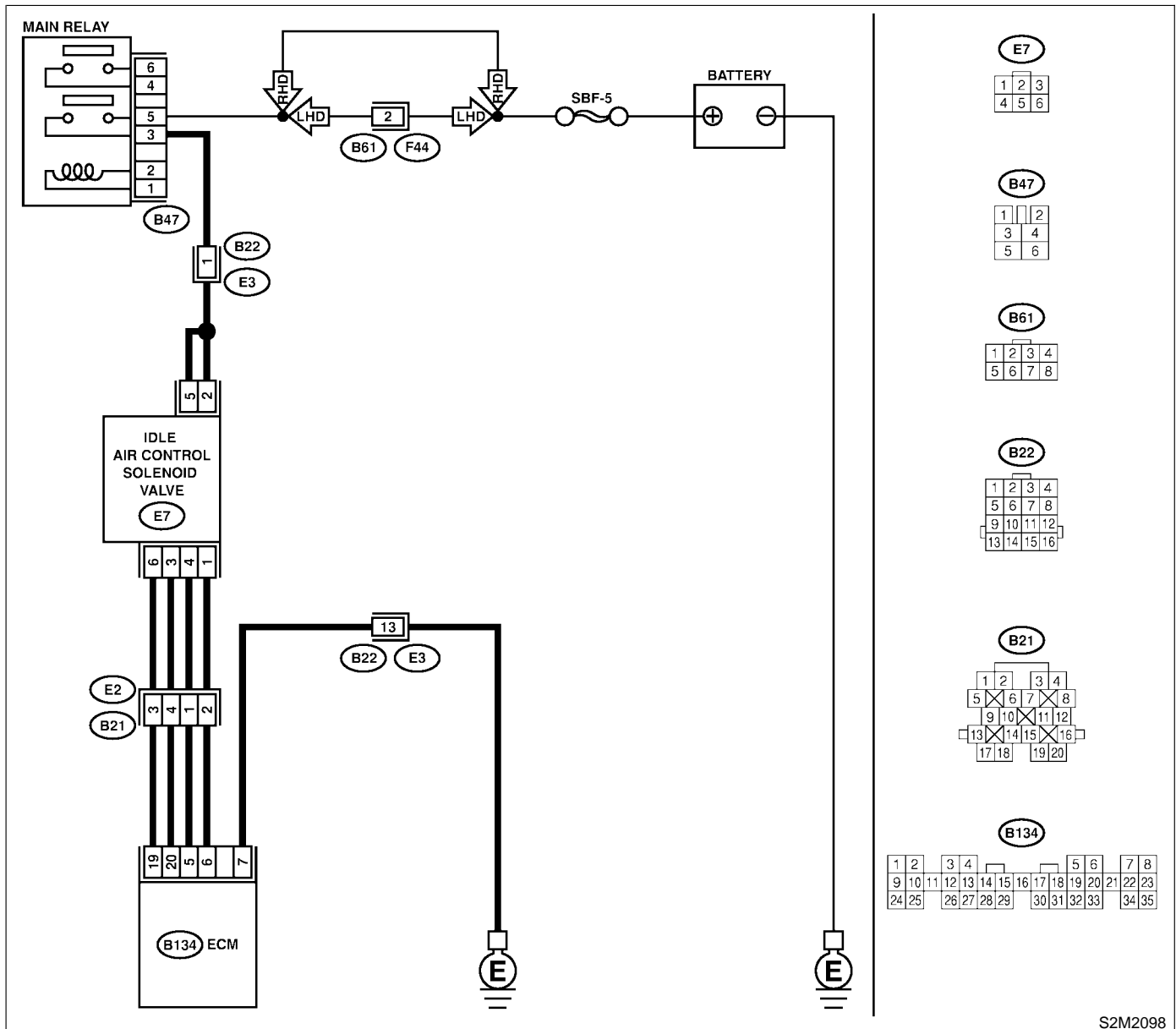

S2M2098

# DIAGNOSTIC PROCEDURE WITH DIAGNOSTIC TROUBLE CODE (DTC)

Engine (Diagnostics)

No.	Step	Check	Yes	No
1	<b>CHECK ANY OTHER DTC ON DISPLAY.</b>	Does the Subaru Select Monitor or OBD-II general scan tool indicate DTC P1511, P1513, P1515 and P1517 at same time?	Go to step 2.	Go to step 3.
2	<b>CHECK GROUND CIRCUIT FOR ECM.</b> 1) Turn ignition switch to OFF. 2) Measure resistance between ECM connector and chassis ground. <b>Connector &amp; terminal</b> <b>(B134) No. 7 — Chassis ground:</b>	Is the resistance less than 5 Ω?	Go to step 3.	Repair harness and connector. <b>NOTE:</b> In this case, repair the following: ● Open circuit in harness between ECM connector and engine ground terminal ● Poor contact in ECM connector ● Poor contact in coupling connector (B22)
3	<b>CHECK HARNESS BETWEEN ECM AND IDLE AIR CONTROL SOLENOID VALVE CONNECTOR.</b> 1) Turn ignition switch to OFF. 2) Disconnect connector from idle air control solenoid valve. 3) Turn ignition switch to ON. 4) Measure voltage between ECM connector and chassis ground. <b>Connector &amp; terminal</b> <b>DTC P1511; (B134) No. 5 (+) — Chassis ground (-):</b> <b>DTC P1513; (B134) No. 6 (+) — Chassis ground (-):</b> <b>DTC P1515; (B134) No. 19 (+) — Chassis ground (-):</b> <b>DTC P1517; (B134) No. 20 (+) — Chassis ground (-):</b>	Is the voltage more than 10 V?	Repair battery short circuit in harness between ECM and idle air control solenoid valve connector. After repair, replace ECM. <Ref. to FU(SOHC)-49, Engine Control Module.>	Replace ECM. <Ref. to FU(SOHC)-49, Engine Control Module.>

# DIAGNOSTIC PROCEDURE WITH DIAGNOSTIC TROUBLE CODE (DTC)

Engine (Diagnostics)

## BW: DTC P1518 — STARTER SWITCH CIRCUIT LOW INPUT — S058521G09

- **DTC DETECTING CONDITION:**
  - Two consecutive driving cycles with fault
- **TROUBLE SYMPTOM:**
  - Failure of engine to start

### CAUTION:

After repair or replacement of faulty parts, conduct Clear Memory Mode <Ref. to EN(SOHC)-45, OPERATION, Clear Memory Mode.> and Inspection Mode <Ref. to EN(SOHC)-42, OPERATION, Inspection Mode.>.

- **WIRING DIAGRAM:**

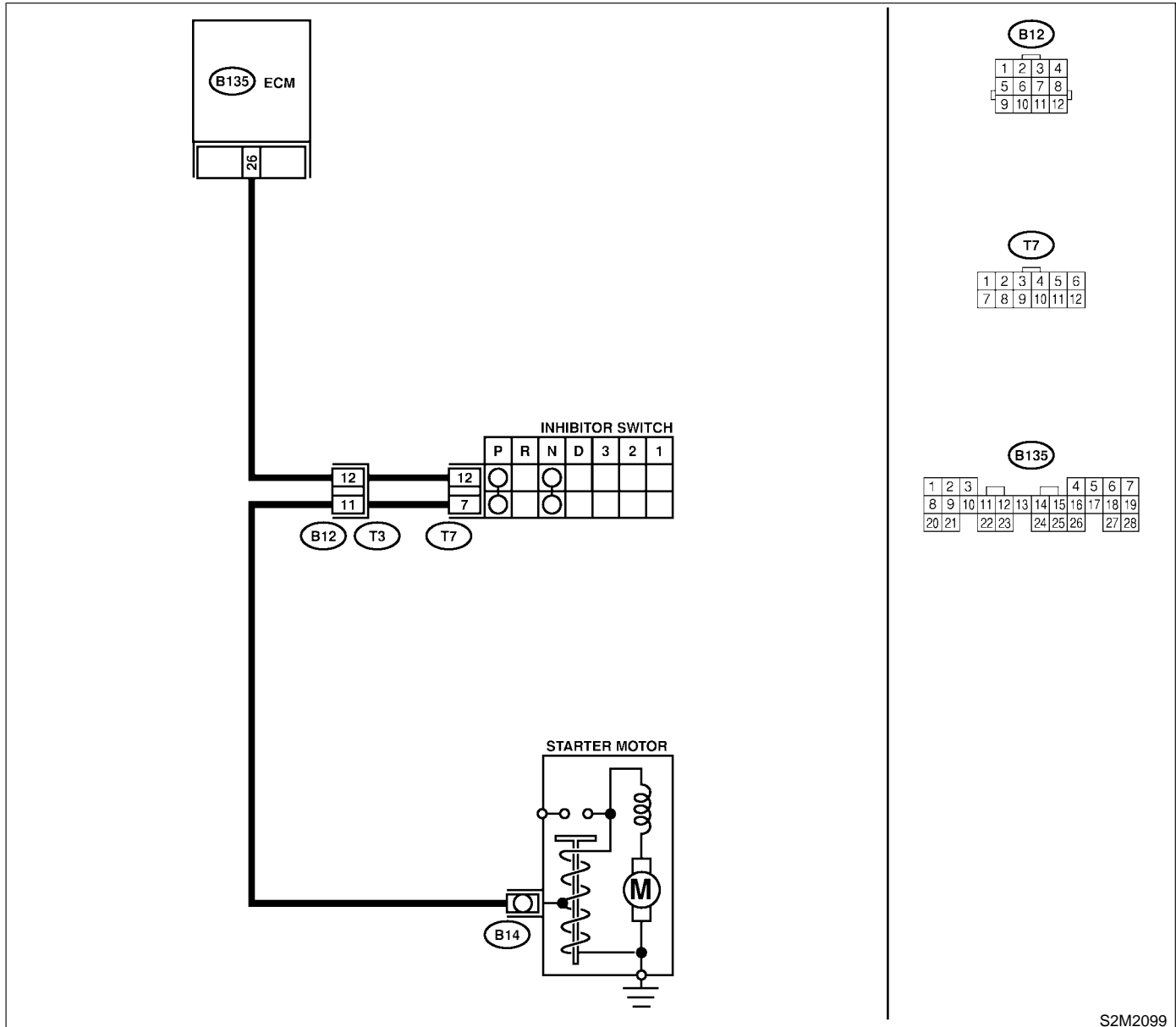

S2M2099



# DIAGNOSTIC PROCEDURE WITH DIAGNOSTIC TROUBLE CODE (DTC)

Engine (Diagnostics)

No.	Step	Check	Yes	No
1	<b>CHECK OPERATION OF STARTER MOTOR.</b> NOTE: Place the inhibitor switch in the "P" or "N" position.	Does starter motor operate when ignition switch to "ST"?	Repair harness and connector. NOTE: In this case, repair the following: <ul style="list-style-type: none"><li>● Open or ground short circuit in harness between ECM and starter motor connector.</li><li>● Poor contact in ECM connector.</li></ul>	Check starter motor circuit. <Ref. to EN(SOHC)-60, STARTER MOTOR CIRCUIT, Diagnostic for Engine Starting Failure.>

# DIAGNOSTIC PROCEDURE WITH DIAGNOSTIC TROUBLE CODE (DTC)

Engine (Diagnostics)

## BX: DTC P1540 — VEHICLE SPEED SENSOR MALFUNCTION 2 — S058521C26

- **DTC DETECTING CONDITION:**
  - Immediately at fault recognition

**CAUTION:**

After repair or replacement of faulty parts, conduct Clear Memory Mode <Ref. to EN(SOHC)-45, OPERATION, Clear Memory Mode.> and Inspection Mode <Ref. to EN(SOHC)-42, OPERATION, Inspection Mode.>.

● **WIRING DIAGRAM:**

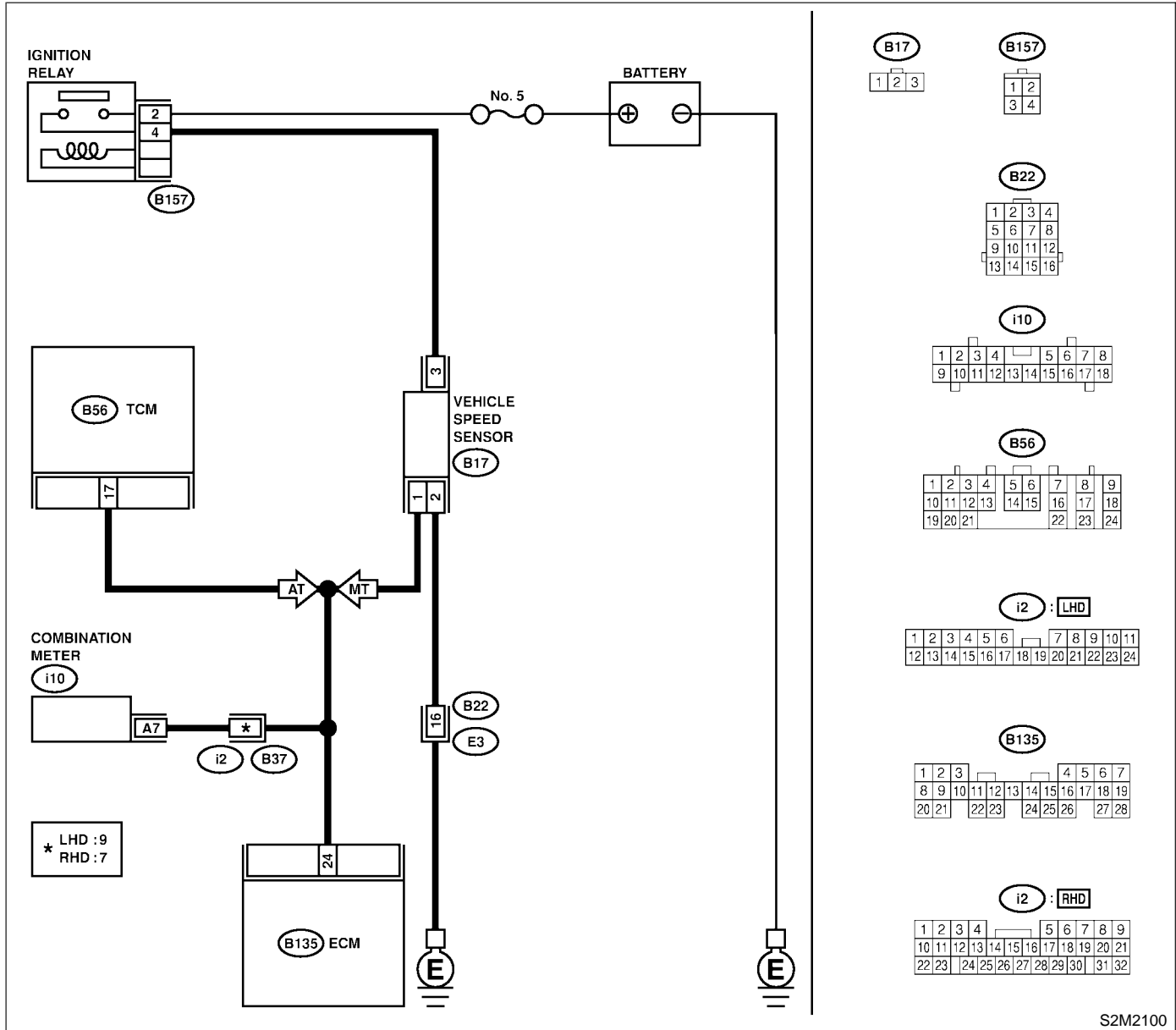

# DIAGNOSTIC PROCEDURE WITH DIAGNOSTIC TROUBLE CODE (DTC)

Engine (Diagnostics)

No.	Step	Check	Yes	No
1	<b>CHECK DTC P0720 ON DISPLAY.</b>	Does the Subaru Select Monitor or OBD-II general scan tool indicate DTC P0720?	Check front vehicle speed sensor signal circuit. <Ref. to AT-58, TROUBLE CODE 33 — FRONT VEHICLE SPEED SENSOR —, Diagnostic Procedure with Trouble Code.>	Go to step 2.
2	<b>CHECK SPEEDOMETER OPERATION IN COMBINATION METER.</b>	Does speedometer operate normally?	Go to step 3.	Check speedometer and vehicle speed sensor. <Ref. to IDI-17, Speedometer.>
3	<b>CHECK HARNESS BETWEEN ECM AND COMBINATION METER CONNECTOR.</b> 1) Turn ignition switch to OFF. 2) Disconnect connector from combination meter. 3) Measure resistance between ECM and combination meter. <b>Connector &amp; terminal</b> <b>(B135) No. 24 — (i10) No. 7:</b>	Is the resistance less than 10 Ω?	Repair poor contact in ECM connector.	Repair harness and connector. <b>NOTE:</b> In this case, repair the following: ● Open circuit in harness between ECM and combination meter connector ● Poor contact in ECM connector ● Poor contact in combination meter connector ● Poor contact in coupling connector (i2)

# DIAGNOSTIC PROCEDURE WITH DIAGNOSTIC TROUBLE CODE (DTC)

Engine (Diagnostics)

## BY: DTC P1560 — BACK-UP VOLTAGE CIRCUIT MALFUNCTION — S058521C27

### ● DTC DETECTING CONDITION:

- Two consecutive driving cycles with fault

### CAUTION:

After repair or replacement of faulty parts, conduct Clear Memory Mode <Ref. to EN(SOHC)-45, OPERATION, Clear Memory Mode.> and Inspection Mode <Ref. to EN(SOHC)-42, OPERATION, Inspection Mode.>.

### ● WIRING DIAGRAM:

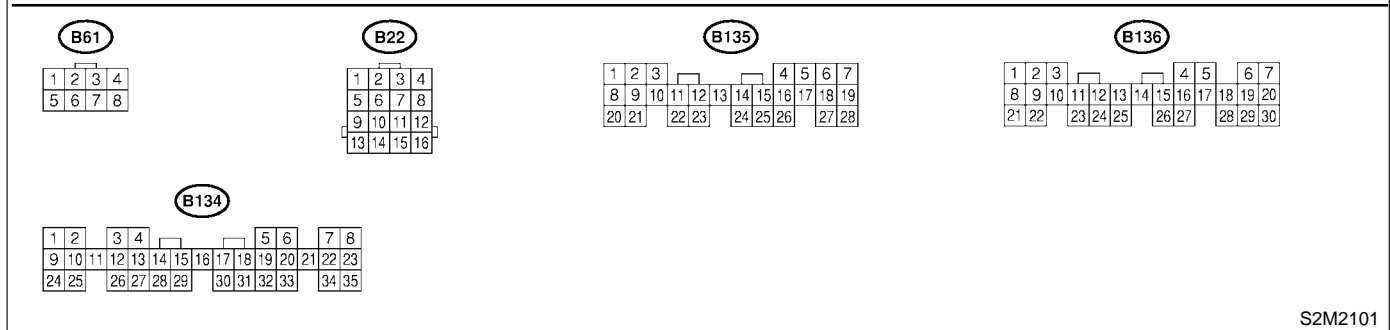
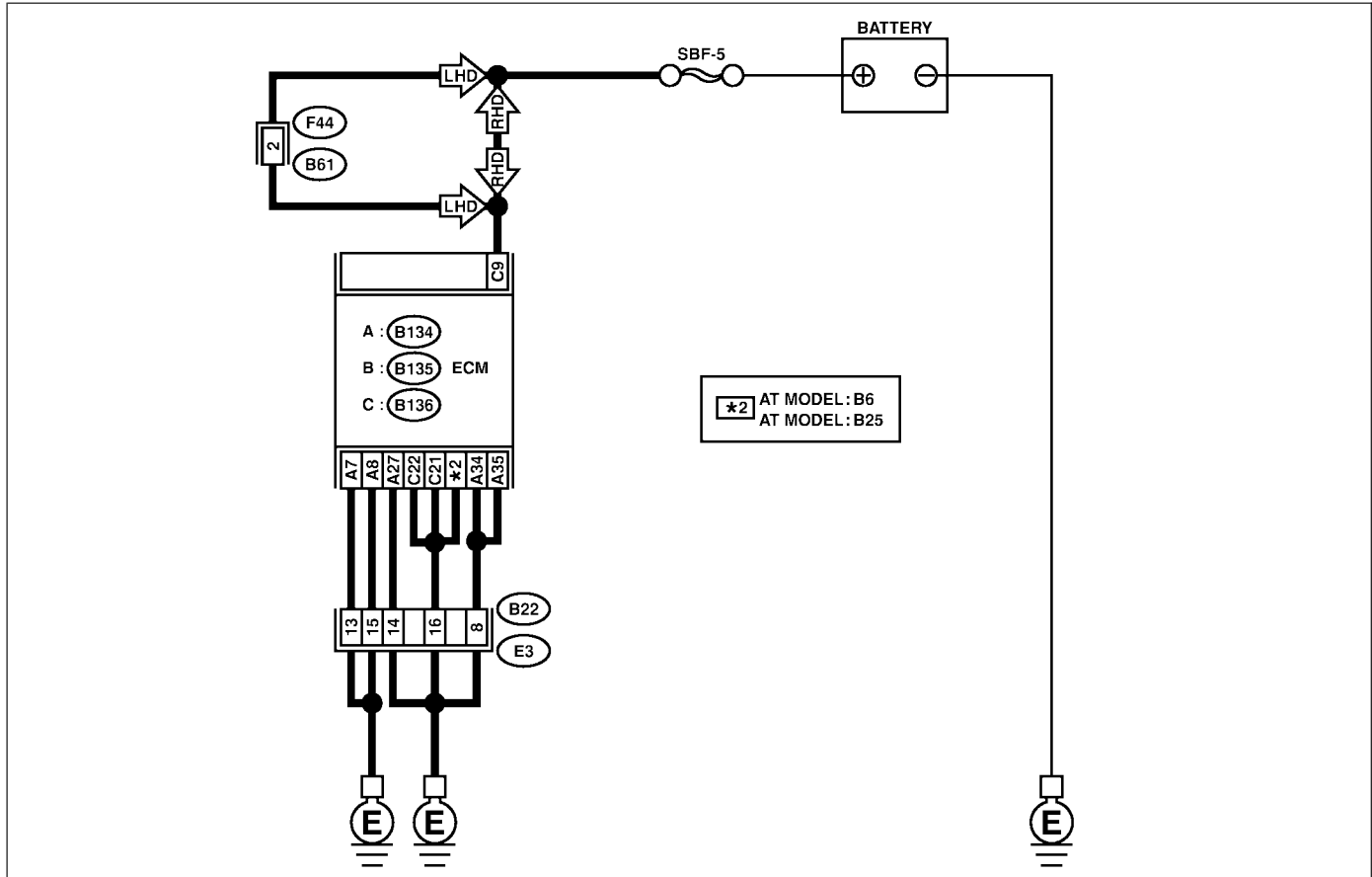

S2M2101

No.	Step	Check	Yes	No
1	<b>CHECK INPUT SIGNAL FOR ECM.</b> 1) Turn ignition switch to OFF. 2) Measure voltage between ECM and chassis ground. <b>Connector &amp; terminal</b> (B136) No. 9 (+) — Chassis ground (-):	Is the voltage more than 10 V?	Repair poor contact in ECM connector.	Go to step 2.

# DIAGNOSTIC PROCEDURE WITH DIAGNOSTIC TROUBLE CODE (DTC)

Engine (Diagnostics)

No.	Step	Check	Yes	No
2	<b>CHECK HARNESS BETWEEN ECM AND MAIN FUSE BOX CONNECTOR.</b> 1) Disconnect connector from ECM. 2) Measure resistance of harness between ECM and chassis ground. <b>Connector &amp; terminal</b> <b>(B136) No. 9 — Chassis ground:</b>	Is the resistance less than 10 $\Omega$ ?	Repair ground short circuit in harness between ECM connector and battery terminal.	Go to step 3.
3	<b>CHECK FUSE SBF-5.</b>	Is fuse blown?	Replace fuse.	Repair harness and connector. NOTE: In this case, repair the following: ● Open circuit in harness between ECM and battery ● Poor contact in ECM connector ● Poor contact in battery terminal

# DIAGNOSTIC PROCEDURE WITH DIAGNOSTIC TROUBLE CODE (DTC)

Engine (Diagnostics)

## BZ: DTC P1590 — NEUTRAL POSITION SWITCH CIRCUIT HIGH INPUT (AT MODEL) — S058521G83

- **DTC DETECTING CONDITION:**
  - Two consecutive driving cycles with fault
- **TROUBLE SYMPTOM:**
  - Erroneous idling

### CAUTION:

After repair or replacement of faulty parts, conduct Clear Memory Mode <Ref. to EN(SOHC)-45, OPERATION, Clear Memory Mode.> and Inspection Mode <Ref. to EN(SOHC)-42, OPERATION, Inspection Mode.>.

### ● WIRING DIAGRAM:

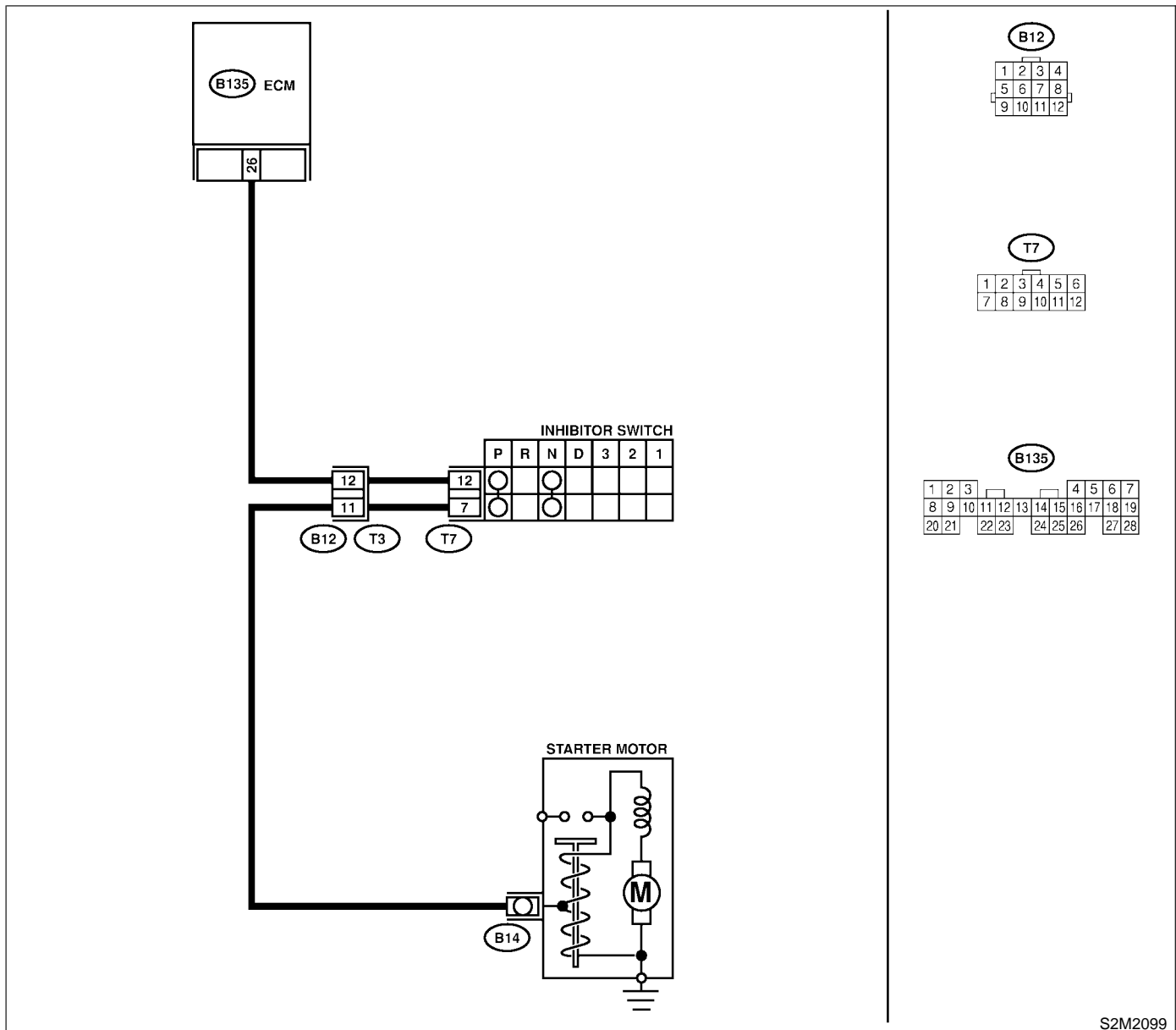

S2M2099

# DIAGNOSTIC PROCEDURE WITH DIAGNOSTIC TROUBLE CODE (DTC)

Engine (Diagnostics)

No.	Step	Check	Yes	No
1	<b>CHECK DTC P0705 ON DISPLAY.</b>	Does the Subaru Select Monitor or OBD-II general scan tool indicate DTC P0705?	Inspect DTC P0705 using "17. List of Diagnostic Trouble Code (DTC)". <Ref. to EN(SOHC)-80, List of Diagnostic Trouble Code (DTC).>	Go to step 2.
2	<b>CHECK INPUT SIGNAL FOR ECM.</b> 1) Turn ignition switch to ON. 2) Measure voltage between ECM and chassis ground in selector lever "N" and "P" positions. <b>Connector &amp; terminal</b> <b>(B135) No. 26 (+) — Chassis ground (-):</b>	Is the voltage less than 1 V?	Go to step 3.	Go to step 5.
3	<b>CHECK INPUT SIGNAL FOR ECM.</b> Measure voltage between ECM and chassis ground in selector lever except for "N" and "P" positions. <b>Connector &amp; terminal</b> <b>(B135) No. 26 (+) — Chassis ground (-):</b>	Is the voltage between 4.5 and 5.5 V?	Go to step 4.	Go to step 5.
4	<b>CHECK POOR CONTACT.</b> Check poor contact in ECM connector.	Is there poor contact in ECM connector?	Repair poor contact in ECM connector.	Contact your Subaru distributor. NOTE: Inspection by DTM is required, because probable cause is deterioration of multiple parts.
5	<b>CHECK INPUT SIGNAL FOR ECM.</b> Measure voltage between ECM and chassis ground. <b>Connector &amp; terminal</b> <b>(B135) No. 26 (+) — Chassis ground (-):</b>	Is the voltage more than 10 V?	Repair battery short circuit in harness between ECM and inhibitor switch connector.	Go to step 6.
6	<b>CHECK HARNESS BETWEEN ECM AND INHIBITOR SWITCH CONNECTOR.</b> 1) Turn ignition switch to OFF. 2) Disconnect connectors from ECM and inhibitor switch. 3) Measure resistance of harness between ECM and inhibitor switch connector. <b>Connector &amp; terminal</b> <b>(B135) No. 26 — (T7) No. 12:</b>	Is the resistance less than 1 Ω?	Go to step 7.	Repair harness and connector. NOTE: In this case, repair the following: ● Open circuit in harness between ECM and inhibitor switch connector ● Poor contact in coupling connector (B12) ● Poor contact in inhibitor switch connector ● Poor contact in ECM connector

# DIAGNOSTIC PROCEDURE WITH DIAGNOSTIC TROUBLE CODE (DTC)

Engine (Diagnostics)

No.	Step	Check	Yes	No
7	<p><b>CHECK INHIBITOR SWITCH GROUND LINE.</b>                      Measure resistance of harness between inhibitor switch connector and engine ground.  <b>Connector &amp; terminal</b>  <i>(T7) No. 7 — Engine ground:</i></p>	<p>Is the resistance less than 5 <math>\Omega</math>?</p>	<p>Go to step 8.</p>	<p>Repair open circuit in harness between inhibitor switch connector and starter motor ground line.                      NOTE:                      In this case, repair the following:</p> <ul style="list-style-type: none"> <li>● Open circuit in harness between inhibitor switch connector and starter motor ground line</li> <li>● Poor contact in starter motor connector</li> <li>● Poor contact in starter motor ground</li> <li>● Starter motor</li> </ul>
8	<p><b>CHECK INHIBITOR SWITCH.</b>                      Measure resistance between inhibitor switch connector receptacle's terminals in selector lever "N" and "P" positions.  <b>Terminals</b>  <i>No. 7 — No. 12:</i></p>	<p>Is the resistance less than 1 <math>\Omega</math>?</p>	<p>Go to step 9.</p>	<p>Replace inhibitor switch. &lt;Ref. to AT-28, Inhibitor Switch.&gt;</p>
9	<p><b>CHECK SELECTOR CABLE CONNECTION.</b></p>	<p>Is there any fault in selector cable connection to inhibitor switch?</p>	<p>Repair selector cable connection. &lt;Ref. to CS-11, INSPECTION, Select Cable.&gt;</p>	<p>Contact your Subaru distributor.                      NOTE:                      Inspection by DTM is required, because probable cause is deterioration of multiple parts.</p>



**MEMO:**

# DIAGNOSTIC PROCEDURE WITH DIAGNOSTIC TROUBLE CODE (DTC)

Engine (Diagnostics)

## CA: DTC P1591 — NEUTRAL POSITION SWITCH CIRCUIT LOW INPUT (AT MODEL) — S058521G84

- **DTC DETECTING CONDITION:**
  - Two consecutive driving cycles with fault
- **TROUBLE SYMPTOM:**
  - Erroneous idling

### CAUTION:

After repair or replacement of faulty parts, conduct Clear Memory Mode <Ref. to EN(SOHC)-45, OPERATION, Clear Memory Mode.> and Inspection Mode <Ref. to EN(SOHC)-42, OPERATION, Inspection Mode.>.

### ● WIRING DIAGRAM:

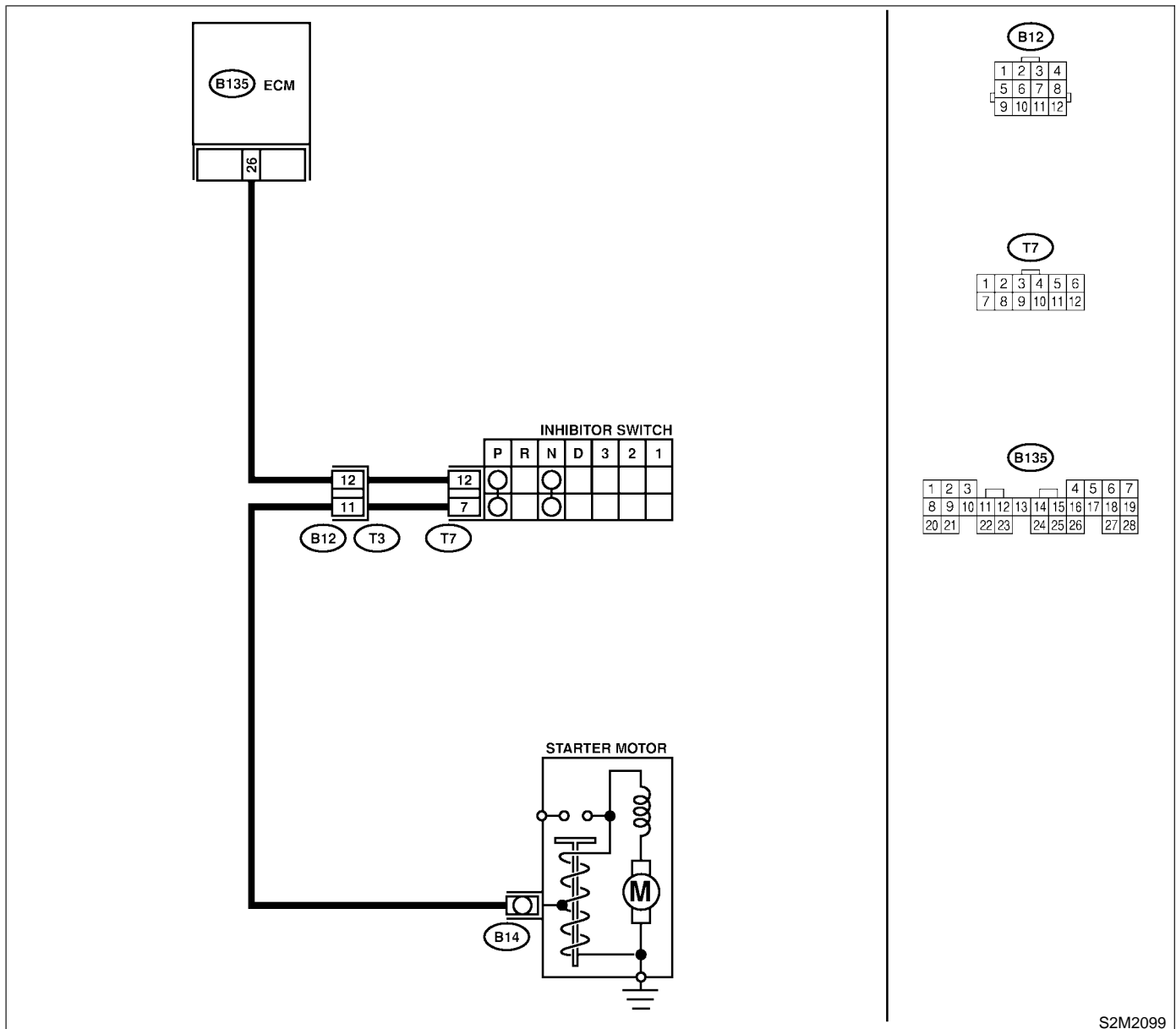

S2M2099

# DIAGNOSTIC PROCEDURE WITH DIAGNOSTIC TROUBLE CODE (DTC)

Engine (Diagnostics)

No.	Step	Check	Yes	No
1	<b>CHECK DTC P0705 ON DISPLAY.</b>	Does the Subaru Select Monitor or OBD-II general scan tool indicate DTC P0705?	Inspect DTC P0705 using "17. List of Diagnostic Trouble Code (DTC)". <Ref. to EN(SOHC)-80, List of Diagnostic Trouble Code (DTC).>	Go to step 2.
2	<b>CHECK INPUT SIGNAL FOR ECM.</b> 1) Turn ignition switch to ON. 2) Measure voltage between ECM and chassis ground. <b>Connector &amp; terminal</b> <b>(B135) No. 26 (+) — Chassis ground (-):</b>	Is the voltage between 4.5 and 5.5 V at except "N" and "P" positions?	Even if MIL lights up, the circuit has returned to a normal condition at this time.	Go to step 3.
3	<b>CHECK HARNESS BETWEEN ECM AND TRANSMISSION HARNESS CONNECTOR.</b> 1) Turn ignition switch to OFF. 2) Disconnect connectors from ECM and transmission harness connector (T3). 3) Measure resistance of harness between ECM connector and chassis ground. <b>Connector &amp; terminal</b> <b>(B135) No. 26 — Chassis ground:</b>	Is the resistance less than 10 Ω?	Repair ground short circuit in harness between ECM and transmission harness connector.	Go to step 4.
4	<b>CHECK TRANSMISSION HARNESS CONNECTOR.</b> 1) Disconnect connector from inhibitor switch. 2) Measure resistance of harness between transmission harness connector and engine ground. <b>Connector &amp; terminal</b> <b>(T3) No. 12 — Engine ground:</b>	Is the resistance less than 10 Ω?	Repair ground short circuit in harness between transmission harness and inhibitor switch connector.	Go to step 5.
5	<b>CHECK INHIBITOR SWITCH.</b> Measure resistance between inhibitor switch connector receptacle's terminals in selector lever except for "N" position. <b>Terminals</b> <b>No. 7 — No. 12:</b>	Is the resistance more than 1 MΩ at except "N" and "P" positions?	Go to step 6.	Replace inhibitor switch. <Ref. to AT-28, Inhibitor Switch.>
6	<b>CHECK SELECTOR CABLE CONNECTION.</b>	Is there any fault in selector cable connection to inhibitor switch?	Repair selector cable connection. <Ref. to CS-11, INSPECTION, Select Cable.>	Contact your Subaru distributor. NOTE: Inspection by DTM is required, because probable cause is deterioration of multiple parts.

# DIAGNOSTIC PROCEDURE WITH DIAGNOSTIC TROUBLE CODE (DTC)

Engine (Diagnostics)

## CB: DTC P1592 — NEUTRAL POSITION SWITCH CIRCUIT LOW INPUT (MT MODEL) — S058521G85

### ● DTC DETECTING CONDITION:

- Two consecutive driving cycles with fault

### ● TROUBLE SYMPTOM:

- Erroneous idling

### CAUTION:

After repair or replacement of faulty parts, conduct Clear Memory Mode <Ref. to EN(SOHC)-45, OPERATION, Clear Memory Mode.> and Inspection Mode <Ref. to EN(SOHC)-42, OPERATION, Inspection Mode.>.

### ● WIRING DIAGRAM:

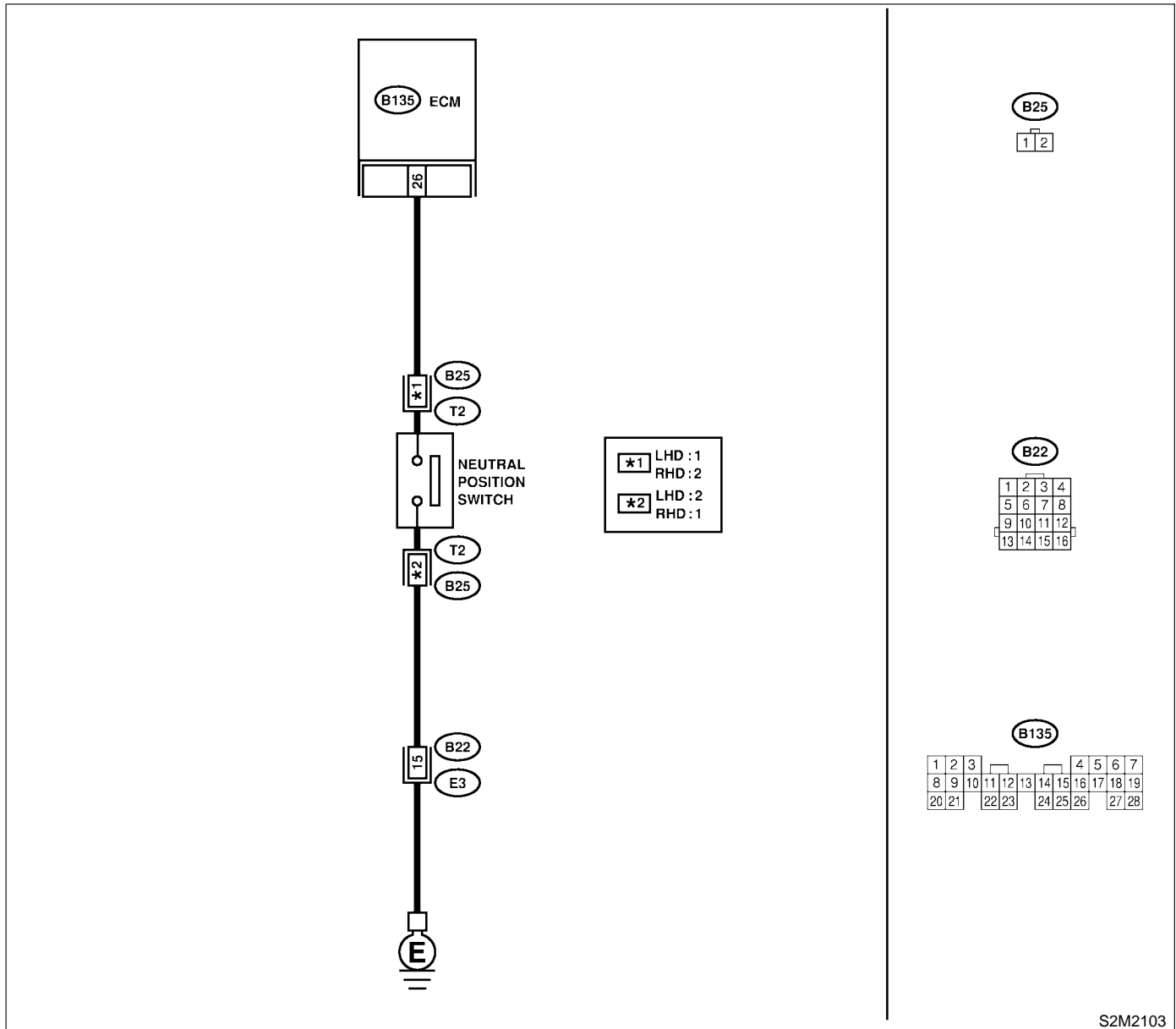

S2M2103

# DIAGNOSTIC PROCEDURE WITH DIAGNOSTIC TROUBLE CODE (DTC)

Engine (Diagnostics)

No.	Step	Check	Yes	No
1	<b>CHECK INPUT SIGNAL FOR ECM.</b> 1) Turn ignition switch to ON. 2) Measure voltage between ECM and chassis ground. <b>Connector &amp; terminal</b> <b>(B135) No. 26 (+) — Chassis ground (-):</b>	Is the voltage more than 10V in neutral position?	Go to step 2.	Go to step 4.
2	<b>CHECK INPUT SIGNAL FOR ECM.</b> Measure voltage between ECM and chassis ground. <b>Connector &amp; terminal</b> <b>(B135) No. 26 (+) — Chassis ground (-):</b>	Is the voltage less than 1V in other position?	Go to step 3.	Go to step 4.
3	<b>CHECK POOR CONTACT.</b> Check poor contact in ECM connector.	Is the poor contact in ECM connector?	Repair poor contact in ECM connector.	Contact your distributor.
4	<b>CHECK NEUTRAL POSITION SWITCH.</b> 1) Turn ignition switch to OFF. 2) Disconnect connector from transmission harness. 3) Measure resistance between transmission harness and connector terminals. <b>Connector &amp; terminal</b> <b>(T2) No. 1 — No. 2:</b>	Is the resistance more than 1M $\Omega$ in neutral position?	Go to step 5.	Repair short circuit in transmission harness or replace neutral position switch.
5	<b>CHECK NEUTRAL POSITION SWITCH.</b> Measure resistance between transmission harness connector terminals.	Is the resistance less than 1 $\Omega$ in other positions?	Go to step 6.	Repair short circuit in transmission harness or replace neutral position switch.
6	<b>CHECK HARNESS BETWEEN ECM AND NEUTRAL POSITION SWITCH CONNECTOR.</b> Measure resistance between ECM and chassis ground. <b>Connector &amp; terminal</b> <b>(B135) No. 26 — Chassis ground:</b>	Is the resistance less than 10 $\Omega$ ?	Repair ground short circuit in harness between ECM and transmission harness connector.	Go to step 7.
7	<b>CHECK HARNESS BETWEEN ECM AND NEUTRAL POSITION SWITCH CONNECTOR.</b> 1) Disconnect connector from ECM. 2) Measure resistance of harness between ECM and transmission harness connector. <b>Connector &amp; terminal</b> <b>LHD: (B135) No. 26 — (B25) No. 1:</b> <b>RHD: (B135) No. 26 — (B25) No. 2:</b>	Is the resistance less than 1 $\Omega$ ?	Go to step 8.	Repair open circuit in harness between ECM and transmission harness connector.
8	<b>CHECK HARNESS BETWEEN ECM AND NEUTRAL POSITION SWITCH CONNECTOR.</b> Measure resistance of harness between transmission harness connector and engine ground. <b>Connector &amp; terminal</b> <b>(B25) No. 2 — Engine ground:</b>	Is the resistance less than 5 $\Omega$ ?	Go to step 9.	Repair open circuit between transmission harness connector and engine ground terminal.
9	<b>CHECK POOR CONTACT.</b> Check poor contact in transmission harness connector.	Is there poor contact in transmission harness connector?	Repair poor contact in transmission harness connector.	Contact your distributor.

# DIAGNOSTIC PROCEDURE WITH DIAGNOSTIC TROUBLE CODE (DTC)

Engine (Diagnostics)

## CC: DTC P1594 — AUTOMATIC TRANSMISSION DIAGNOSIS INPUT SIGNAL CIRCUIT MALFUNCTION — S058521G12

### ● DTC DETECTING CONDITION:

- Two consecutive driving cycles with fault

### CAUTION:

After repair or replacement of faulty parts, conduct Clear Memory Mode <Ref. to EN(SOHC)-45, OPERATION, Clear Memory Mode.> and Inspection Mode <Ref. to EN(SOHC)-42, OPERATION, Inspection Mode.>.

### ● WIRING DIAGRAM:

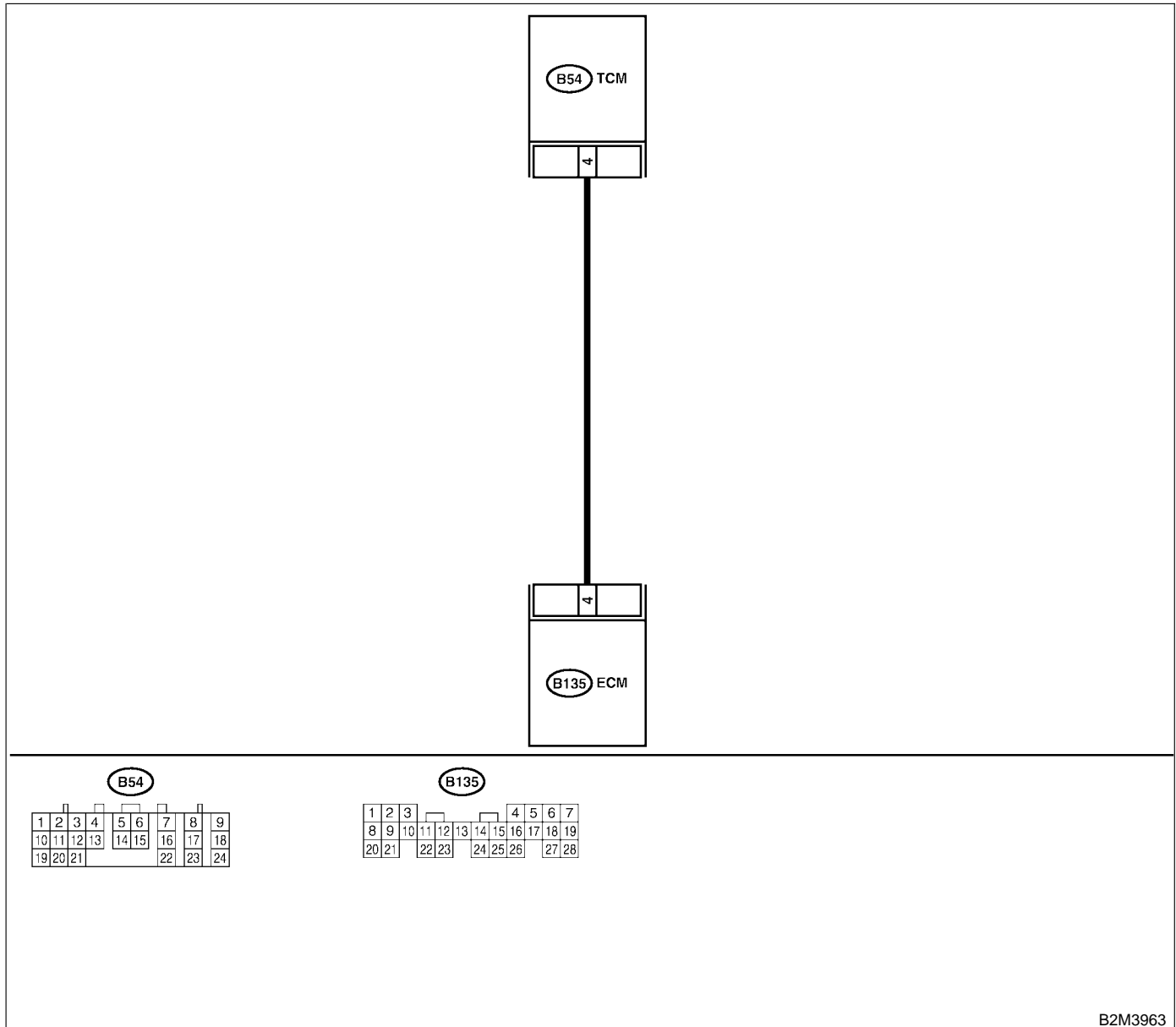

No.	Step	Check	Yes	No
1	<b>CHECK DRIVING CONDITION.</b> 1) Start and warm-up the engine until the radiator fan makes one complete rotation. 2) Drive the vehicle.	Is AT shift control functioning properly?	Go to step 2.	Replace TCM. <Ref. to AT-48, Transmission Control Module (TCM).>

# DIAGNOSTIC PROCEDURE WITH DIAGNOSTIC TROUBLE CODE (DTC)

Engine (Diagnostics)

No.	Step	Check	Yes	No
2	CHECK ACCESSORY.	Are car phone and/or CB installed on vehicle?	Repair grounding line of car phone or CB system.	Replace TCM. <Ref. to AT-48, Transmission Control Module (TCM).>

# DIAGNOSTIC PROCEDURE WITH DIAGNOSTIC TROUBLE CODE (DTC)

Engine (Diagnostics)

## CD: DTC P1595 — AUTOMATIC TRANSMISSION DIAGNOSIS INPUT SIGNAL CIRCUIT LOW INPUT — S058521G13

### ● DTC DETECTING CONDITION:

- Two consecutive driving cycles with fault

### CAUTION:

After repair or replacement of faulty parts, conduct Clear Memory Mode <Ref. to EN(SOHC)-45, OPERATION, Clear Memory Mode.> and Inspection Mode <Ref. to EN(SOHC)-42, OPERATION, Inspection Mode.>.

### ● WIRING DIAGRAM:

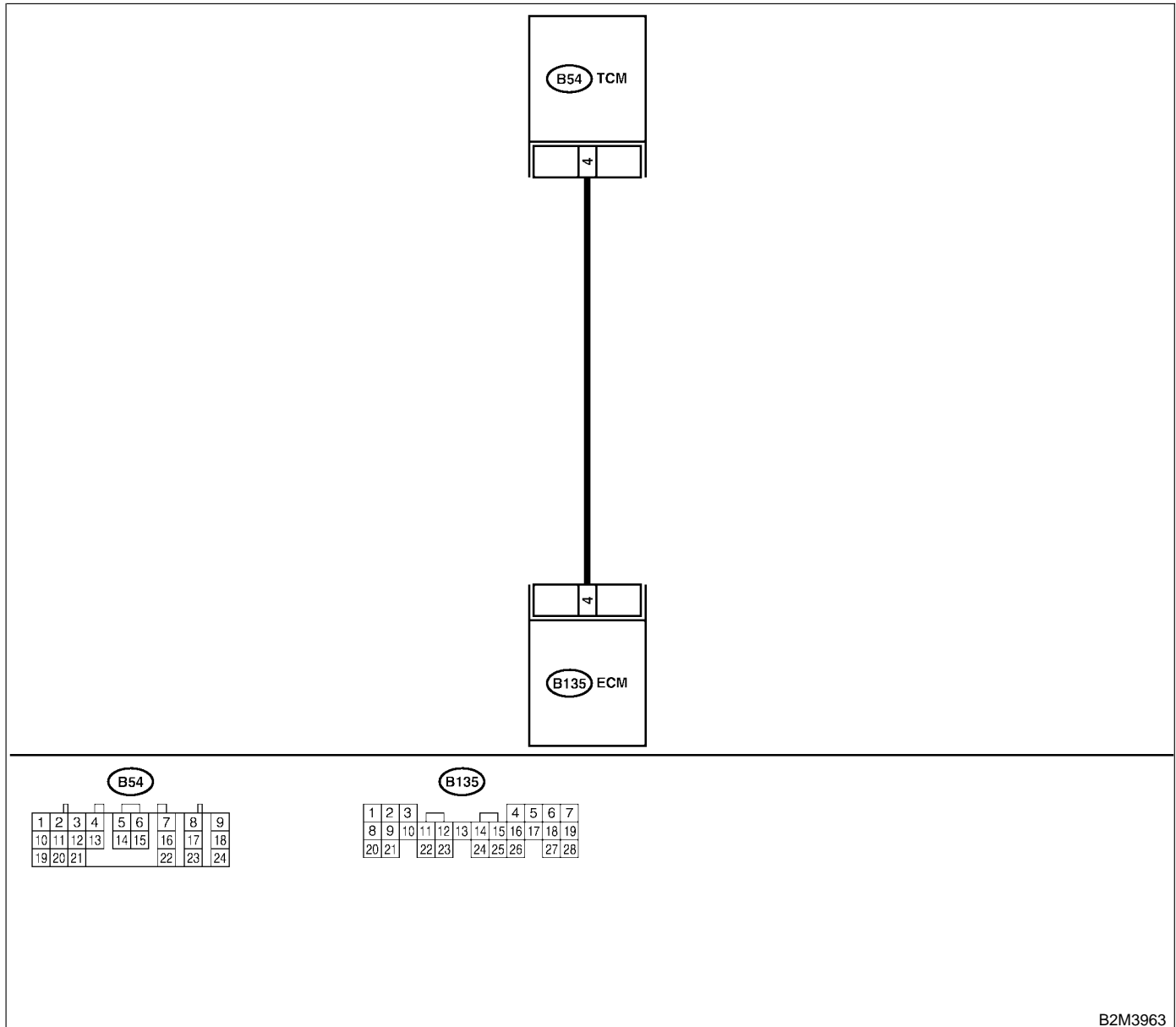

B2M3963



# DIAGNOSTIC PROCEDURE WITH DIAGNOSTIC TROUBLE CODE (DTC)

Engine (Diagnostics)

No.	Step	Check	Yes	No
1	<p><b>CHECK HARNESS BETWEEN ECM AND TCM CONNECTOR.</b></p> <p>1) Turn ignition switch to ON. 2) Measure voltage between ECM and chassis ground.</p> <p><b>Connector &amp; terminal</b> <b>(B135) No. 4 (+) — Chassis ground (-):</b></p>	Is the voltage less than 1 V?	Go to step 2.	Even if MIL lights up, the circuit has returned to a normal condition at this time. NOTE: In this case, repair the following: ● Poor contact in ECM connector ● Poor contact in TCM connector
2	<p><b>CHECK HARNESS BETWEEN ECM AND TCM CONNECTOR.</b></p> <p>1) Turn ignition switch to OFF. 2) Disconnect connector from ECM and TCM. 3) Measure resistance of harness between ECM and chassis ground.</p> <p><b>Connector &amp; terminal</b> <b>(B135) No. 4 — Chassis ground:</b></p>	Is the resistance less than 10 Ω?	Repair ground short circuit in harness between ECM and TCM connector.	Go to step 3.
3	<p><b>CHECK OUTPUT SIGNAL FOR ECM.</b></p> <p>1) Connect connector to ECM. 2) Turn ignition switch to ON. 3) Measure voltage between ECM and chassis ground.</p> <p><b>Connector &amp; terminal</b> <b>(B135) No. 4 (+) — Chassis ground (-):</b></p>	Is the voltage more than 5 V?	Go to step 4.	Repair poor contact in ECM connector.
4	<p><b>CHECK TROUBLE CODE FOR AUTOMATIC TRANSMISSION.</b></p> <p>Read trouble code for automatic transmission. &lt;Ref. to AT-22, Read Diagnostic Trouble Code.&gt;</p>	Does trouble code appear for automatic transmission?	Inspect trouble code for automatic transmission. <Ref. to AT-42, Diagnostic Procedure with Trouble Code.>	Replace TCM. <Ref. to AT-48, Transmission Control Module (TCM).>

# DIAGNOSTIC PROCEDURE WITH DIAGNOSTIC TROUBLE CODE (DTC)

Engine (Diagnostics)

## CE: DTC P1596 — AUTOMATIC TRANSMISSION DIAGNOSIS INPUT SIGNAL CIRCUIT HIGH INPUT — S058521G14

### ● DTC DETECTING CONDITION:

- Two consecutive driving cycles with fault

### CAUTION:

After repair or replacement of faulty parts, conduct Clear Memory Mode <Ref. to EN(SOHC)-45, OPERATION, Clear Memory Mode.> and Inspection Mode <Ref. to EN(SOHC)-42, OPERATION, Inspection Mode.>.

### ● WIRING DIAGRAM:

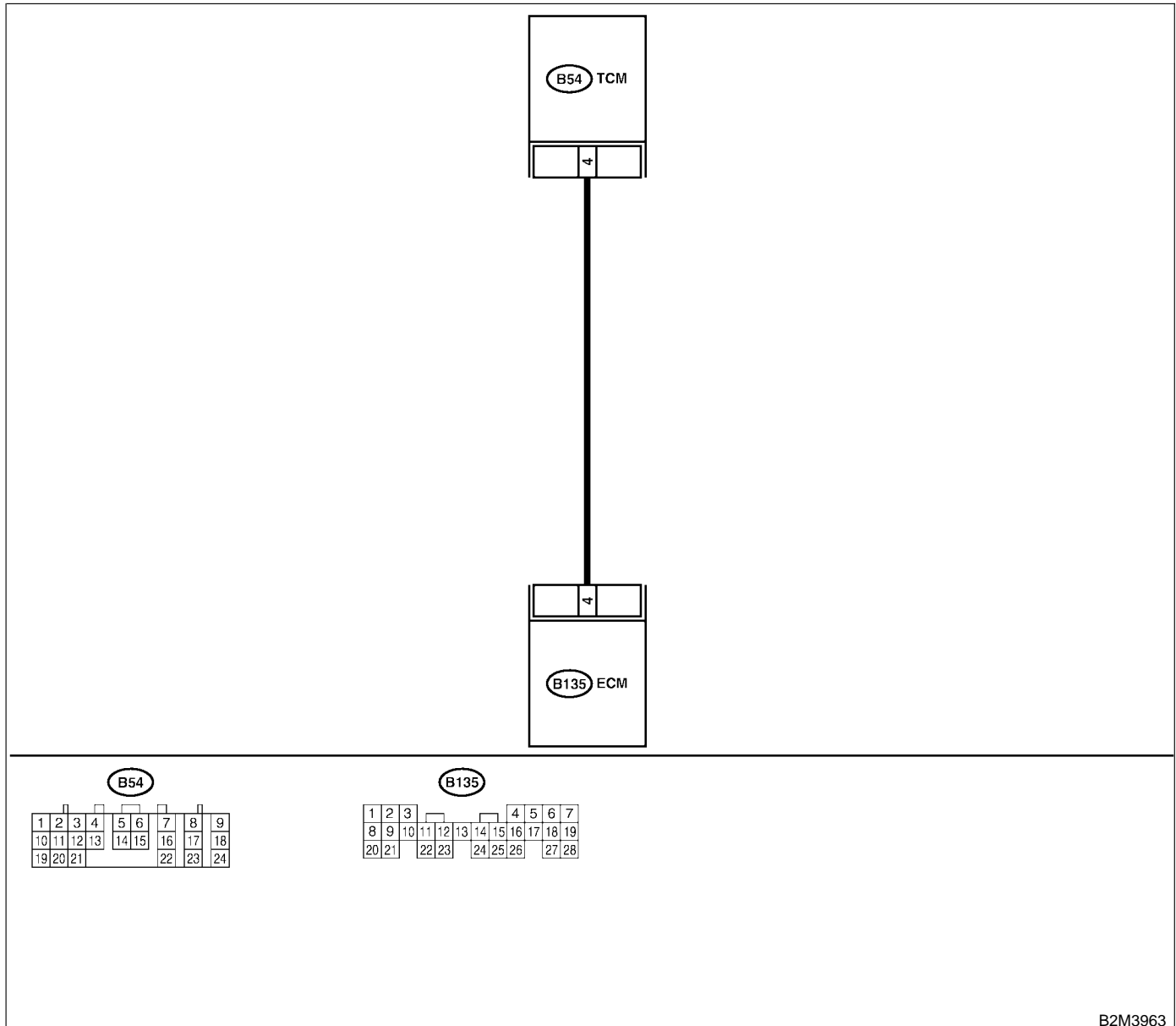

B2M3963

# DIAGNOSTIC PROCEDURE WITH DIAGNOSTIC TROUBLE CODE (DTC)

Engine (Diagnostics)

No.	Step	Check	Yes	No
1	<b>CHECK HARNESS BETWEEN ECM AND TCM CONNECTOR.</b> 1) Turn ignition switch to ON. 2) Measure voltage between ECM and chassis ground. <i>Connector &amp; terminal</i> <i>(B135) No. 4 (+) — Chassis ground (-):</i>	Is the voltage more than 10 V?	Repair battery short circuit in harness between ECM and TCM connector. After repair, replace ECM. <Ref. to FU(SOHC)-49, Engine Control Module.>	Go to step 2.
2	<b>CHECK HARNESS BETWEEN ECM AND TCM CONNECTOR.</b> Measure voltage between ECM connector and chassis ground. <i>Connector &amp; terminal</i> <i>(B135) No. 4 (+) — Chassis ground (-):</i>	Is the voltage more than 4 V?	Go to step 5.	Go to step 3.
3	<b>CHECK HARNESS BETWEEN ECM AND TCM CONNECTOR.</b> Measure voltage between ECM connector and chassis ground. <i>Connector &amp; terminal</i> <i>(B135) No. 4 (+) — Chassis ground (-):</i>	Is the voltage less than 1 V?	Repair poor contact in ECM connector.	Go to step 4.
4	<b>CHECK OUTPUT SIGNAL FROM ECM.</b> Measure voltage between ECM and chassis ground. <i>Connector &amp; terminal</i> <i>(B135) No. 4 (+) — Chassis ground (-):</i>	Does the voltage change from 1 V to 4 V while monitoring the value with voltage meter?	Even if MIL lights up, the circuit has returned to a normal condition at this time. NOTE: In this case, repair the following: <ul style="list-style-type: none"> <li>● Poor contact in ECM connector</li> <li>● Poor contact in TCM connector</li> </ul>	Contact your Subaru distributor. NOTE: Inspection by DTM is required, because probable cause is deterioration of multiple parts.
5	<b>CHECK HARNESS BETWEEN ECM AND TCM CONNECTOR.</b> Measure voltage between TCM and chassis ground. <i>Connector &amp; terminal</i> <i>(B54) No. 4 (+) — Chassis ground (-):</i>	Is the voltage more than 4 V?	Go to step 6.	Repair open circuit in harness between ECM and TCM connector.
6	<b>CHECK POOR CONTACT.</b> Check poor contact in TCM connector.	Is there poor contact in TCM connector?	Repair poor contact in TCM connector.	Check TCM power supply line and grounding line.

# DIAGNOSTIC PROCEDURE WITH DIAGNOSTIC TROUBLE CODE (DTC)

Engine (Diagnostics)

## CF: DTC P1698 — ENGINE TORQUE CONTROL CUT SIGNAL CIRCUIT LOW INPUT — S058521G15

### ● DTC DETECTING CONDITION:

- Two consecutive driving cycles with fault

### CAUTION:

After repair or replacement of faulty parts, conduct Clear Memory Mode <Ref. to EN(SOHC)-45, OPERATION, Clear Memory Mode.> and Inspection Mode <Ref. to EN(SOHC)-42, OPERATION, Inspection Mode.>.

### ● WIRING DIAGRAM:

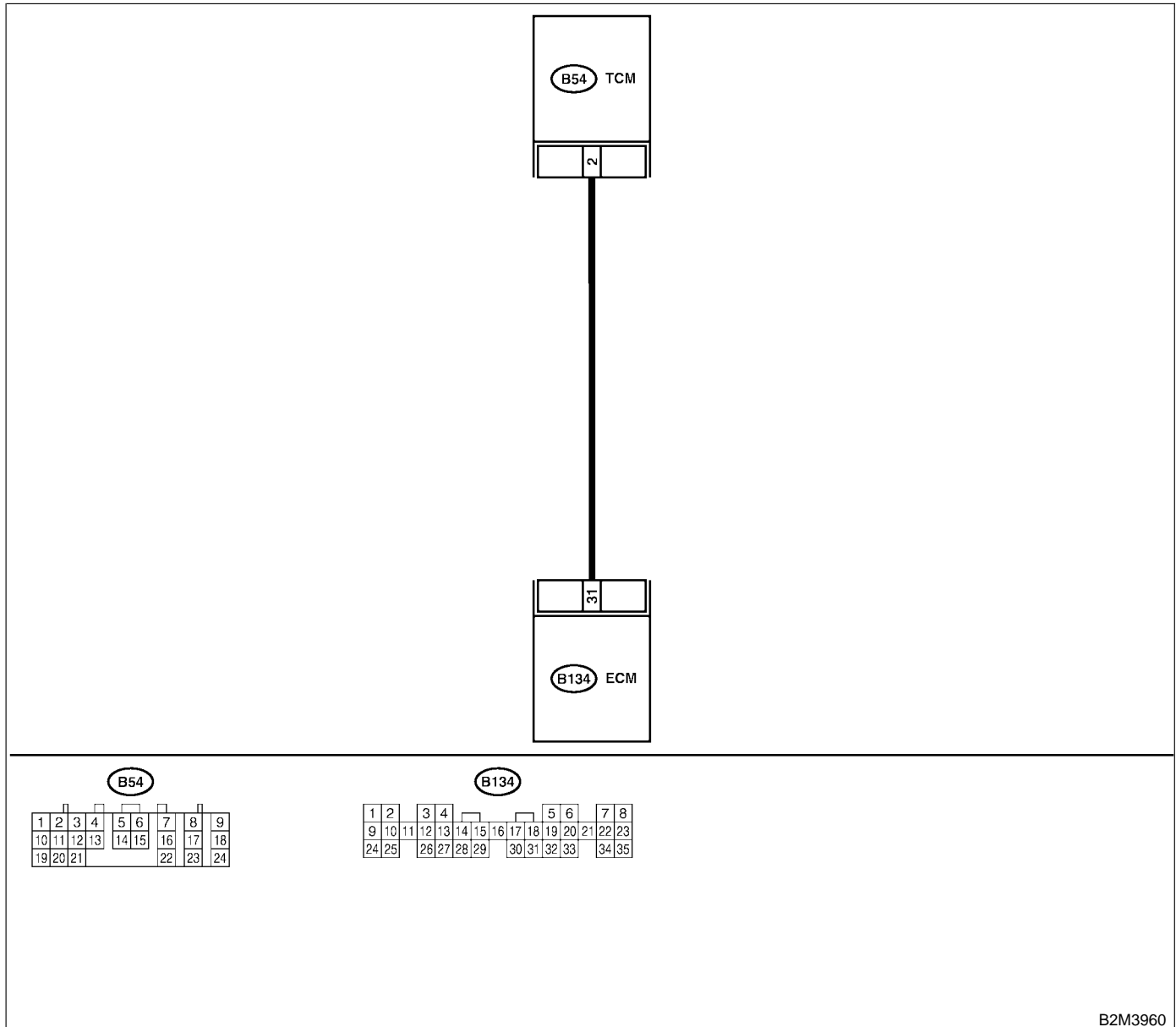

B2M3960

# DIAGNOSTIC PROCEDURE WITH DIAGNOSTIC TROUBLE CODE (DTC)

Engine (Diagnostics)

No.	Step	Check	Yes	No
1	<b>CHECK OUTPUT SIGNAL FROM ECM.</b> 1) Start engine, and warm-up the engine. 2) Turn ignition switch to OFF. 3) Turn ignition switch to ON. 4) Measure voltage between ECM and chassis ground. <b>Connector &amp; terminal</b> <b>(B134) No. 31 (+) — Chassis ground (-):</b>	Is the voltage more than 3 V?	Repair poor contact in ECM connector.	Go to step 2.
2	<b>CHECK HARNESS BETWEEN ECM AND TCM CONNECTOR.</b> 1) Turn ignition switch to OFF. 2) Disconnect connectors from ECM and TCM. 3) Measure resistance of harness between ECM and chassis ground. <b>Connector &amp; terminal</b> <b>(B134) No. 31 — Chassis ground:</b>	Is the resistance less than 10 Ω?	Repair ground short circuit in harness between ECM and TCM connector.	Go to step 3.
3	<b>CHECK HARNESS BETWEEN ECM AND TCM CONNECTOR.</b> Measure resistance of harness between ECM and TCM connector. <b>Connector &amp; terminal</b> <b>(B134) No. 31 — (B54) No. 2:</b>	Is the resistance less than 1 Ω?	Repair poor contact in ECM or TCM connector.	Repair open circuit in harness between ECM and TCM connector.

# DIAGNOSTIC PROCEDURE WITH DIAGNOSTIC TROUBLE CODE (DTC)

Engine (Diagnostics)

## CG: DTC P1699 — ENGINE TORQUE CONTROL CUT SIGNAL CIRCUIT HIGH INPUT — S058521G16

### ● DTC DETECTING CONDITION:

- Two consecutive driving cycles with fault

### CAUTION:

After repair or replacement of faulty parts, conduct Clear Memory Mode <Ref. to EN(SOHC)-45, OPERATION, Clear Memory Mode.> and Inspection Mode <Ref. to EN(SOHC)-42, OPERATION, Inspection Mode.>.

### ● WIRING DIAGRAM:

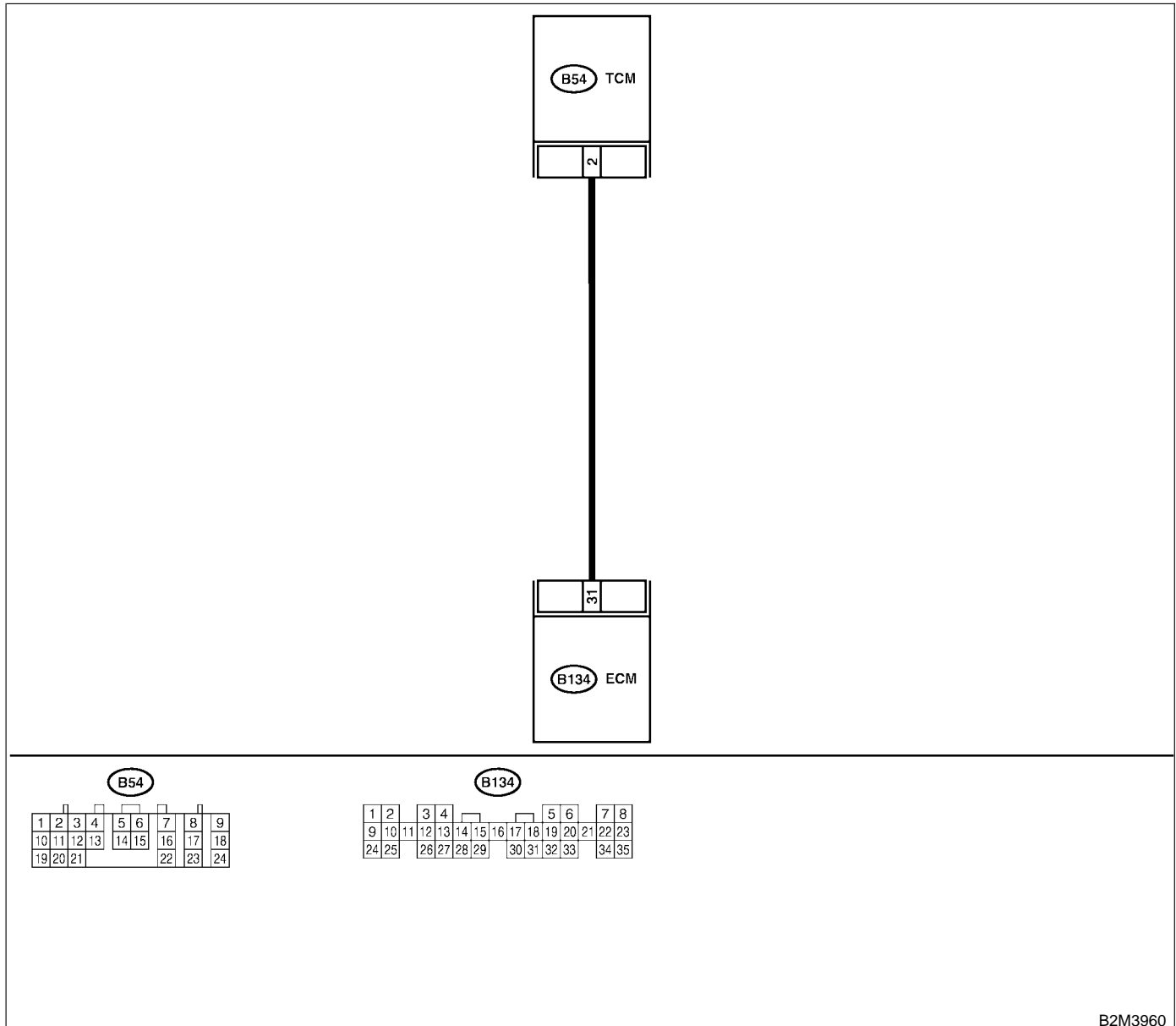

B2M3960

# DIAGNOSTIC PROCEDURE WITH DIAGNOSTIC TROUBLE CODE (DTC)

Engine (Diagnostics)

No.	Step	Check	Yes	No
1	<p><b>CHECK OUTPUT SIGNAL FROM ECM.</b></p> <p>1) Start engine, and warm-up the engine.                      2) Turn ignition switch to OFF.                      3) Disconnect connector from TCM.                      4) Turn ignition switch to ON.                      5) Measure voltage between ECM and chassis ground.</p> <p><b>Connector &amp; terminal</b>  <b>(B134) No. 31 (+) — Chassis ground</b>                      (-):</p>	Is the voltage less than 3 V?	Go to step 2.	Repair battery short circuit in harness between ECM and TCM connector. After repair, replace ECM. <Ref. to FU(SOHC)-49, Engine Control Module.>
2	<p><b>CHECK HARNESS BETWEEN ECM AND TCM CONNECTOR.</b></p> <p>1) Turn ignition switch to OFF.                      2) Measure voltage between ECM and chassis ground.</p> <p><b>Connector &amp; terminal</b>  <b>(B134) No. 31 (+) — Chassis ground</b>                      (-):</p>	Does the voltage change more than 10 V by shaking harness and connector of ECM while monitoring the value with voltage meter?	Repair battery short circuit in harness between ECM and TCM connector. After repair, replace ECM. <Ref. to FU(SOHC)-49, Engine Control Module.>	Contact your Subaru distributor. NOTE: Inspection by DTM is required, because probable cause is deterioration of multiple parts.

# DIAGNOSTIC PROCEDURE WITH DIAGNOSTIC TROUBLE CODE (DTC)

Engine (Diagnostics)

## CH: DTC P1701 — CRUISE CONTROL SET SIGNAL CIRCUIT MALFUNCTION FOR AUTOMATIC TRANSMISSION — S058521C29

### ● DTC DETECTING CONDITION:

- Two consecutive driving cycles with fault

### CAUTION:

After repair or replacement of faulty parts, conduct Clear Memory Mode <Ref. to EN(SOHC)-45, OPERATION, Clear Memory Mode.> and Inspection Mode <Ref. to EN(SOHC)-42, OPERATION, Inspection Mode.>.

### ● WIRING DIAGRAM:

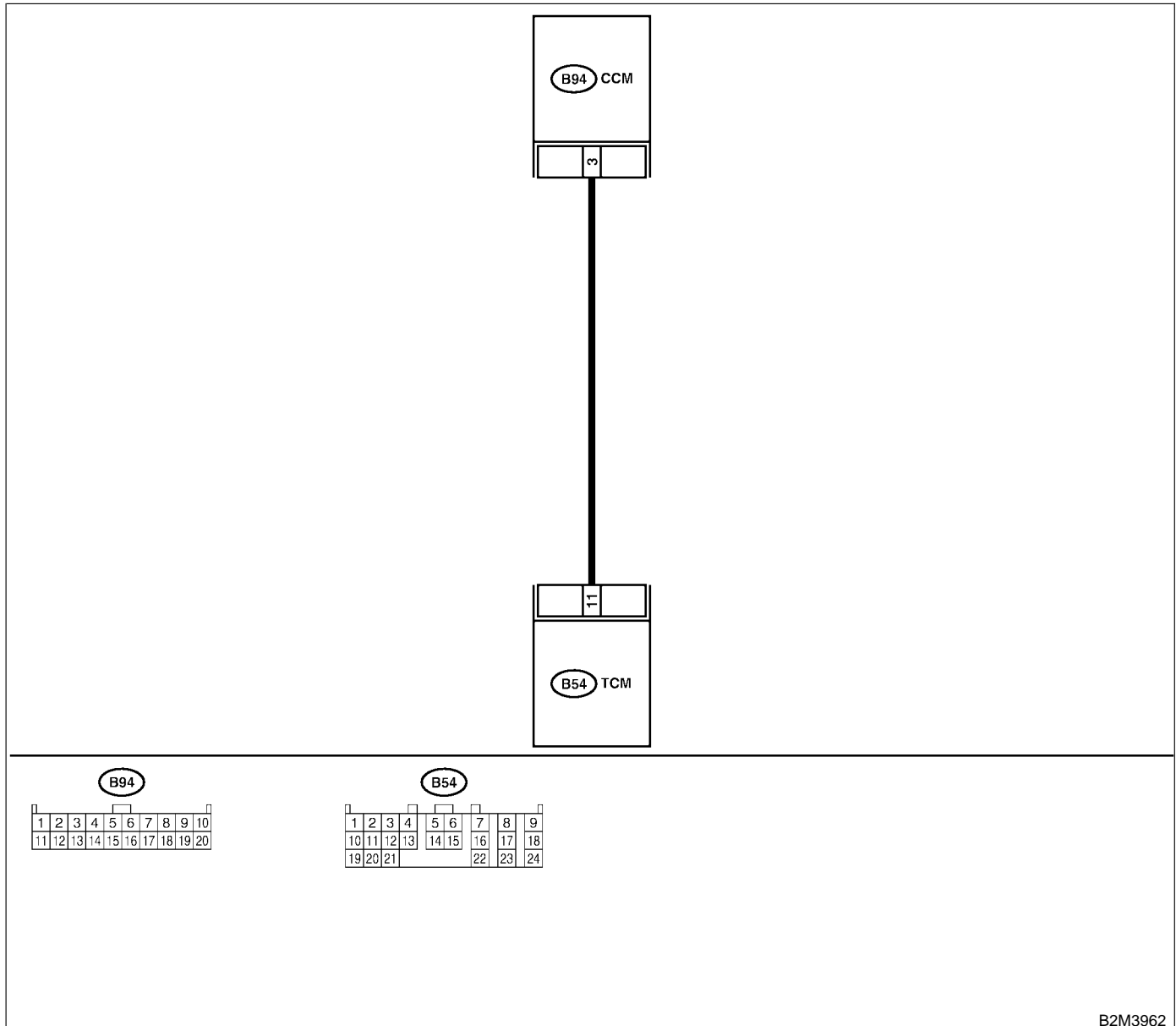

B2M3962



# DIAGNOSTIC PROCEDURE WITH DIAGNOSTIC TROUBLE CODE (DTC)

Engine (Diagnostics)

No.	Step	Check	Yes	No
1	<p><b>CHECK HARNESS BETWEEN TCM AND CCM CONNECTOR.</b>                      1) Turn ignition switch to OFF.                      2) Disconnect connectors from TCM and CCM.                      3) Measure resistance of harness between TCM and CCM connector.  <b>Connector &amp; terminal</b>  <b>(B54) No. 11 — (B94) No. 3:</b></p>	Is the resistance less than 1 Ω?	Go to step 2.	Repair open circuit in harness between TCM and CCM connector.
2	<p><b>CHECK HARNESS BETWEEN TCM AND CCM CONNECTOR.</b>                      Measure resistance of harness between TCM and chassis ground.  <b>Connector &amp; terminal</b>  <b>(B54) No. 11 — Chassis ground:</b></p>	Is the resistance less than 10 Ω?	Repair short circuit in harness between TCM and CCM connector.	Go to step 3.
3	<p><b>CHECK INPUT SIGNAL FOR TCM.</b>                      1) Connect connector to TCM and CCM.                      2) Lift-up the vehicle or set the vehicle on free rollers.  <b>CAUTION:</b>  <b>On AWD models, raise all wheels off ground.</b>                      3) Start the engine.                      4) Cruise control main switch to ON.                      5) Move selector lever to "D" and slowly increase vehicle speed to 50 km/h (31 MPH).                      6) Cruise control command switch to ON.                      7) Measure voltage between TCM and chassis ground.  <b>Connector &amp; terminal</b>  <b>(B54) No. 11 (+) — Chassis ground (-):</b></p>	Is the resistance less than 1 V?	Go to step 4.	Check cruise control command switch circuit. <Ref. to CC-10, INSPECTION, Cruise Control Command Switch.>
4	<p><b>CHECK POOR CONTACT.</b>                      Check poor contact in TCM connector.</p>	Is there poor contact in TCM connector?	Repair poor contact in TCM connector.	Replace TCM. <Ref. to AT-48, Transmission Control Module (TCM).>

# DIAGNOSTIC PROCEDURE WITH DIAGNOSTIC TROUBLE CODE (DTC)

Engine (Diagnostics)

## CI: DTC P1711 — ENGINE TORQUE CONTROL SIGNAL 1 CIRCUIT MALFUNCTION — S058521G17

### ● DTC DETECTING CONDITION:

- Two consecutive driving cycles with fault

### ● TROUBLE SYMPTOM:

- Excessive shift shock

### CAUTION:

After repair or replacement of faulty parts, conduct Clear Memory Mode <Ref. to EN(SOHC)-45, OPERATION, Clear Memory Mode.> and Inspection Mode <Ref. to EN(SOHC)-42, OPERATION, Inspection Mode.>.

### ● WIRING DIAGRAM:

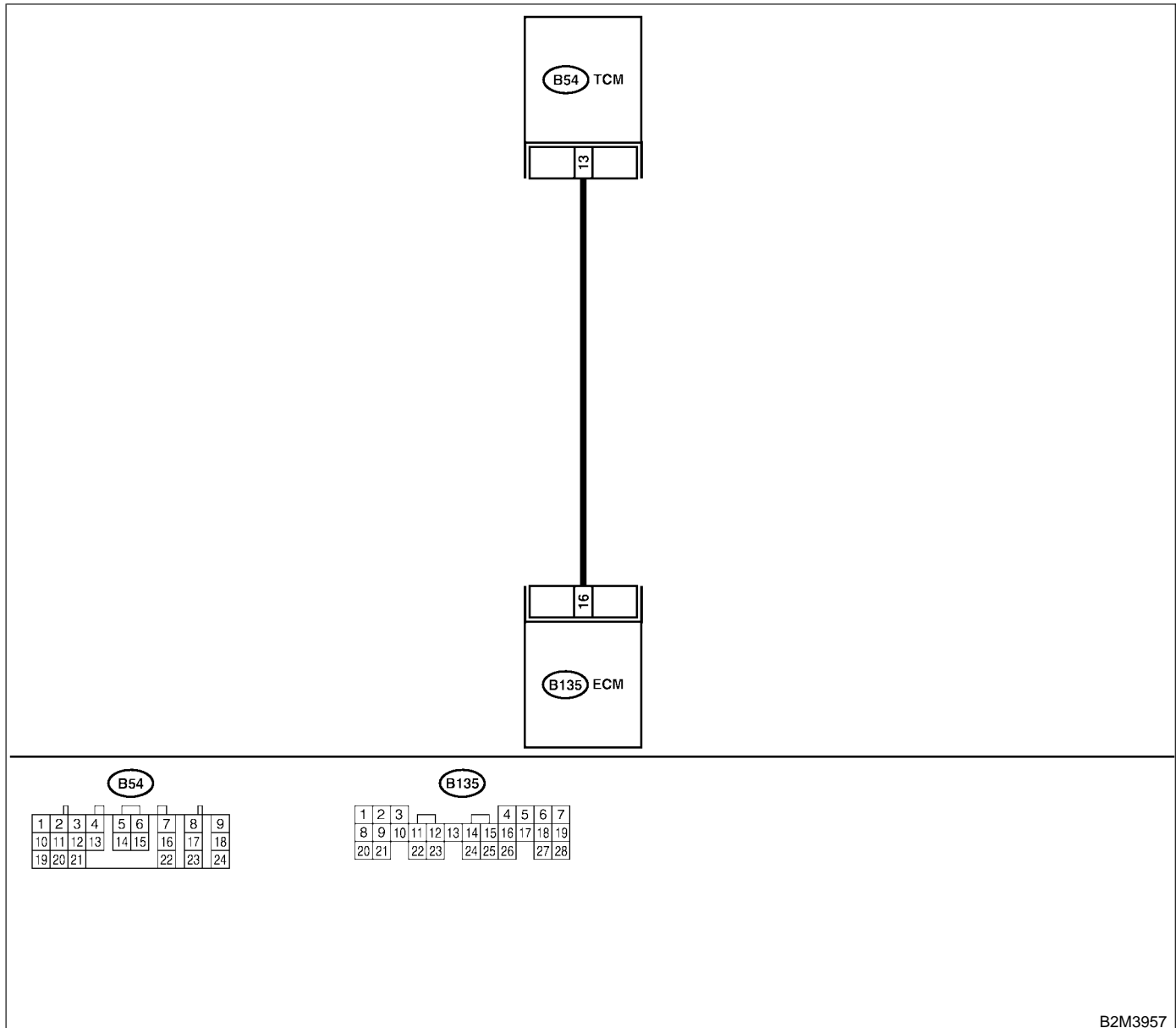

B2M3957

# DIAGNOSTIC PROCEDURE WITH DIAGNOSTIC TROUBLE CODE (DTC)

Engine (Diagnostics)

No.	Step	Check	Yes	No
1	<b>CHECK INPUT SIGNAL FOR ECM.</b> 1) Turn ignition switch to ON. 2) Measure voltage between ECM and chassis ground. <b>Connector &amp; terminal</b> <b>(B135) No. 16 (+) — Chassis ground (-):</b>	Is the voltage more than 4.5 V?	Go to step 2.	Go to step 4.
2	<b>CHECK INPUT SIGNAL FOR ECM.</b> Measure voltage between ECM and chassis ground. <b>Connector &amp; terminal</b> <b>(B135) No. 16 (+) — Chassis ground (-):</b>	Is the voltage more than 10 V?	Repair battery short circuit in harness between ECM and TCM connector.	Go to step 3.
3	<b>CHECK POOR CONTACT.</b> Check poor contact in ECM connector.	Is there poor contact in ECM connector?	Repair poor contact in ECM connector.	Replace ECM. <Ref. to FU(SOHC)-49, Engine Control Module.>
4	<b>CHECK HARNESS BETWEEN ECM AND TCM CONNECTOR.</b> 1) Turn ignition switch to OFF. 2) Disconnect connectors from ECM and TCM. 3) Measure resistance of harness between ECM and TCM connector. <b>Connector &amp; terminal</b> <b>(B135) No. 16 — (B54) No. 13:</b>	Is the resistance less than 1 $\Omega$ ?	Go to step 5.	Repair open circuit in harness between ECM and TCM connector.
5	<b>CHECK HARNESS BETWEEN ECM AND TCM CONNECTOR.</b> Measure resistance of harness between ECM and chassis ground. <b>Connector &amp; terminal</b> <b>(B135) No. 16 — Chassis ground:</b>	Is the resistance less than 10 $\Omega$ ?	Repair ground short circuit in harness between ECM and TCM connector.	Go to step 6.
6	<b>CHECK POOR CONTACT.</b> Check poor contact in TCM connector.	Is there poor contact in TCM connector?	Repair poor contact in TCM connector.	Replace TCM. <Ref. to AT-48, Transmission Control Module (TCM).>

# DIAGNOSTIC PROCEDURE WITH DIAGNOSTIC TROUBLE CODE (DTC)

Engine (Diagnostics)

## CJ: DTC P1712 — ENGINE TORQUE CONTROL SIGNAL 2 CIRCUIT MALFUNCTION — S058521G18

### ● DTC DETECTING CONDITION:

- Two consecutive driving cycles with fault

### ● TROUBLE SYMPTOM:

- Excessive shift shock

### CAUTION:

After repair or replacement of faulty parts, conduct Clear Memory Mode <Ref. to EN(SOHC)-45, OPERATION, Clear Memory Mode.> and Inspection Mode <Ref. to EN(SOHC)-42, OPERATION, Inspection Mode.>.

### ● WIRING DIAGRAM:

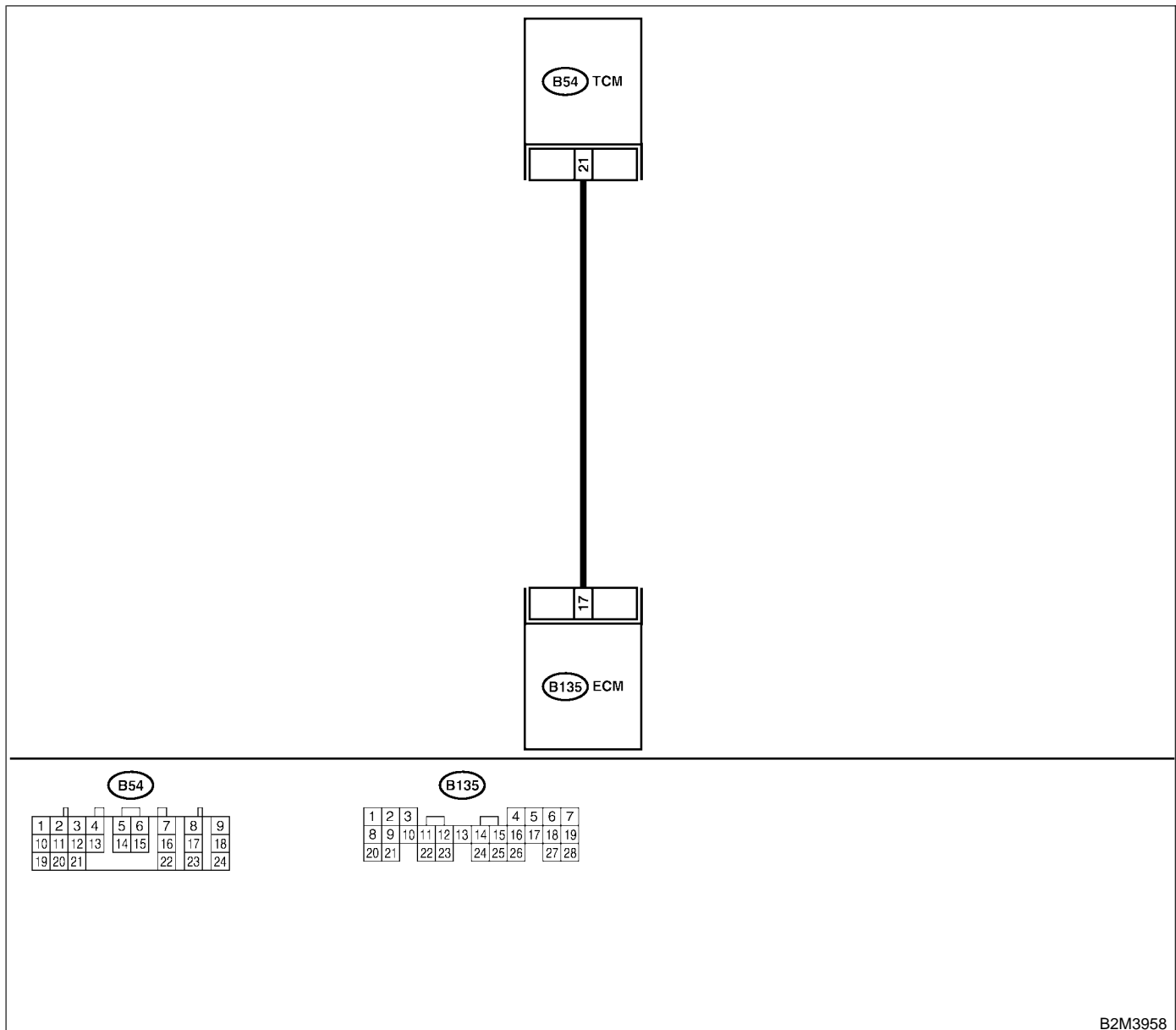

B2M3958

# DIAGNOSTIC PROCEDURE WITH DIAGNOSTIC TROUBLE CODE (DTC)

Engine (Diagnostics)

No.	Step	Check	Yes	No
1	<b>CHECK INPUT SIGNAL FOR ECM.</b> 1) Turn ignition switch to ON. 2) Measure voltage between ECM and chassis ground. <b>Connector &amp; terminal</b> <b>(B135) No. 17 (+) — Chassis ground (-):</b>	Is the voltage more than 4.5 V?	Go to step 2.	Go to step 4.
2	<b>CHECK INPUT SIGNAL FOR ECM.</b> Measure voltage between ECM and chassis ground. <b>Connector &amp; terminal</b> <b>(B135) No. 17 (+) — Chassis ground (-):</b>	Is the voltage more than 10 V?	Repair battery short circuit in harness between ECM and TCM connector.	Go to step 3.
3	<b>CHECK POOR CONTACT.</b> Check poor contact in ECM connector.	Is there poor contact in ECM connector?	Repair poor contact in ECM connector.	Replace ECM. <Ref. to FU(SOHC)-49, Engine Control Module.>
4	<b>CHECK HARNESS BETWEEN ECM AND TCM CONNECTOR.</b> 1) Turn ignition switch to OFF. 2) Disconnect connectors from ECM and TCM. 3) Measure resistance of harness between ECM and TCM connector. <b>Connector &amp; terminal</b> <b>(B135) No. 17 — (B54) No. 21:</b>	Is the resistance less than 1 $\Omega$ ?	Go to step 5.	Repair open circuit in harness between ECM and TCM connector.
5	<b>CHECK HARNESS BETWEEN ECM AND TCM CONNECTOR.</b> Measure resistance of harness between ECM and chassis ground. <b>Connector &amp; terminal</b> <b>(B135) No. 17 — Chassis ground:</b>	Is the resistance less than 10 $\Omega$ ?	Repair ground short circuit in harness between ECM and TCM connector.	Go to step 6.
6	<b>CHECK POOR CONTACT.</b> Check poor contact in TCM connector.	Is there poor contact in TCM connector?	Repair poor contact in TCM connector.	Replace TCM. <Ref. to AT-48, Transmission Control Module (TCM).>

# GENERAL DIAGNOSTIC TABLE

Engine (Diagnostics)

## 19. General Diagnostic Table

S058257

### A: INSPECTION S058257A10

#### 1. ENGINE S058257A1001

NOTE:

Malfunction of parts other than those listed is also possible. <Ref. to ME(SOHC)-87, Engine Trouble in General.>

Symptom	Problem parts
1. Engine stalls during idling.	1) Idle air control solenoid valve 2) Intake air temperature and pressure sensor 3) Ignition parts (*1) 4) Engine coolant temperature sensor (*2) 5) Crankshaft position sensor (*3) 6) Camshaft position sensor (*3) 7) Fuel injection parts (*4)
2. Rough idling	1) Idle air control solenoid valve 2) Intake air temperature and pressure sensor 3) Engine coolant temperature sensor (*2) 4) Ignition parts (*1) 5) Air intake system (*5) 6) Fuel injection parts (*4) 7) Throttle position sensor 8) Crankshaft position sensor (*3) 9) Camshaft position sensor (*3) 10) Oxygen sensor 11) Fuel pump and fuel pump relay
3. Engine does not return to idle.	1) Idle air control solenoid valve 2) Engine coolant temperature sensor 3) Accelerator cable (*6) 4) Throttle position sensor 5) Intake air temperature and pressure sensor
4. Poor acceleration	1) Intake air temperature and pressure sensor 2) Throttle position sensor 3) Fuel injection parts (*4) 4) Fuel pump and fuel pump relay 5) Engine coolant temperature sensor (*2) 6) Crankshaft position sensor (*3) 7) Camshaft position sensor (*3) 8) A/C switch and A/C cut relay 9) Engine torque control signal circuit 10) Ignition parts (*1)
5. Engine stalls or engine sags or hesitates at acceleration.	1) Intake air temperature and pressure sensor 2) Engine coolant temperature sensor (*2) 3) Crankshaft position sensor (*3) 4) Camshaft position sensor (*3) 5) Purge control solenoid valve 6) Fuel injection parts (*4) 7) Throttle position sensor 8) Fuel pump and fuel pump relay

# GENERAL DIAGNOSTIC TABLE

Engine (Diagnostics)

Symptom	Problem parts
6. Surge	1) Intake manifold pressure sensor 2) Intake air temperature sensor 3) Intake air temperature and pressure sensor 4) Engine coolant temperature sensor (*2) 5) Crankshaft position sensor (*3) 6) Camshaft position sensor (*3) 7) Fuel injection parts (*4) 8) Throttle position sensor 9) Fuel pump and fuel pump relay
7. Spark knock	1) Intake manifold pressure sensor 2) Intake air temperature sensor 3) Intake air temperature and pressure sensor 4) Engine coolant temperature sensor 5) Knock sensor 6) Fuel injection parts (*4) 7) Fuel pump and fuel pump relay
8. After burning in exhaust system	1) Intake manifold pressure sensor 2) Intake air temperature sensor 3) Intake air temperature and pressure sensor 4) Engine coolant temperature sensor (*2) 5) Fuel injection parts (*4) 6) Fuel pump and fuel pump relay

\*1: Check ignition coil & ignitor assembly and spark plug.

\*2: Indicate the symptom occurring only in cold temperatures.

\*3: Ensure the secure installation.

\*4: Check fuel injector, fuel pressure regulator and fuel filter.

\*5: Inspect air leak in air intake system.

\*6: Adjust accelerator cable.

## 2. AUTOMATIC TRANSMISSION S058257A1002

### NOTE:

Check general diagnostics table with non-conformity symptom for automatic transmission. <Ref. to AT-2, Basic Diagnostic Procedure.>

# GENERAL DIAGNOSTIC TABLE

Engine (Diagnostics)

---

**MEMO:**