

COOLING

CO

	Page
1. General Description.....	2
2. Radiator Main Fan System	8
3. Radiator Sub Fan System	11
4. Engine Coolant.....	14
5. Water Pump	16
6. Thermostat	23
7. Radiator	25
8. Radiator Cap	31
9. Radiator Main Fan and Fan Motor.....	32
10. Radiator Sub Fan and Fan Motor	34
11. Reservoir Tank	36
12. Coolant Filler Tank	37
13. Engine Cooling System Trouble in General.....	38

GENERAL DESCRIPTION

Cooling

1. General Description S176001

A: SPECIFICATIONS S176001E49

Model		Non-turbo	Turbo	
Cooling system		Electric fan + Forced engine coolant circulation system		
Total engine coolant capacity <i>ℓ</i> (US qt, Imp qt)		AT: Approx. 6.3 (6.7, 5.5) MT: Approx. 6.4 (6.8, 5.6)	Approx. 7.2 (7.6, 6.3)	
Water pump	Type	Centrifugal impeller type		
	Discharge performance I	Discharge	20 <i>ℓ</i> (5.3 US gal, 4.4 Imp gal)/min.	
		Pump speed—total engine coolant head	700 rpm — 0.3 mAq (1.0 ftAq)	
		Engine coolant temperature	85°C (185°F)	
	Discharge performance II	Discharge	100 <i>ℓ</i> (26.4 US gal, 22.0 Imp gal)/min.	
		Pump speed—total engine coolant head	3,000 rpm — 5.0 mAq (16.4 ftAq)	
		Engine coolant temperature	85°C (185°F)	
	Discharge performance III	Discharge	200 <i>ℓ</i> (52.8 US gal, 44.0 Imp gal)/min.	
		Pump speed—total engine coolant head	6,000 rpm — 23.0 mAq (75.5 ftAq)	
		Engine coolant temperature	85°C (185°F)	
	Impeller diameter		76 mm (2.99 in)	
	Number of impeller vanes		8	
	Pump pulley diameter		60 mm (2.36 in)	
Clearance between impeller and case	Standard	0.5 — 0.7 mm (0.020 — 0.028 in)		
	Limit	1.0 mm (0.039 in)		
"Thrust" runout of impeller end		0.5 mm (0.020 in)		
Thermostat	Type	Wax pellet type		
	Starts to open	76 — 80°C (169 — 176°F)		
	Fully opened	91°C (196°F)		
	Valve lift	9.0 mm (0.354 in) or more		
	Valve bore	35 mm (1.38 in)		
Radiator fan	Motor	Main fan	70 W	
		Sub fan	70 W	
Fan diameter × Blade		320 mm (12.60 in) × 5 (main fan) 320 mm (12.60 in) × 7 (sub fan)		
Radiator	Type	Down flow, pressure type		
	Core dimensions	691.5 × 340 × 16 mm (27.22 × 13.39 × 0.63 in)		
	Pressure range in which cap valve is open	Above: 108±15 kPa (1.1±0.15 kg/cm ² , 16±2 psi) Below: -1.0 to -4.9 kPa (-0.01 to -0.05 kg/cm ² , -0.1 to -0.7 psi)		
	Fins	Corrugated fin type		
Reservoir tank	Capacity	0.45 <i>ℓ</i> (0.5 US qt, 0.4 Imp qt)		

B: COMPONENT S176001A05

1. WATER PUMP S176001A0501

● NON-TURBO MODEL

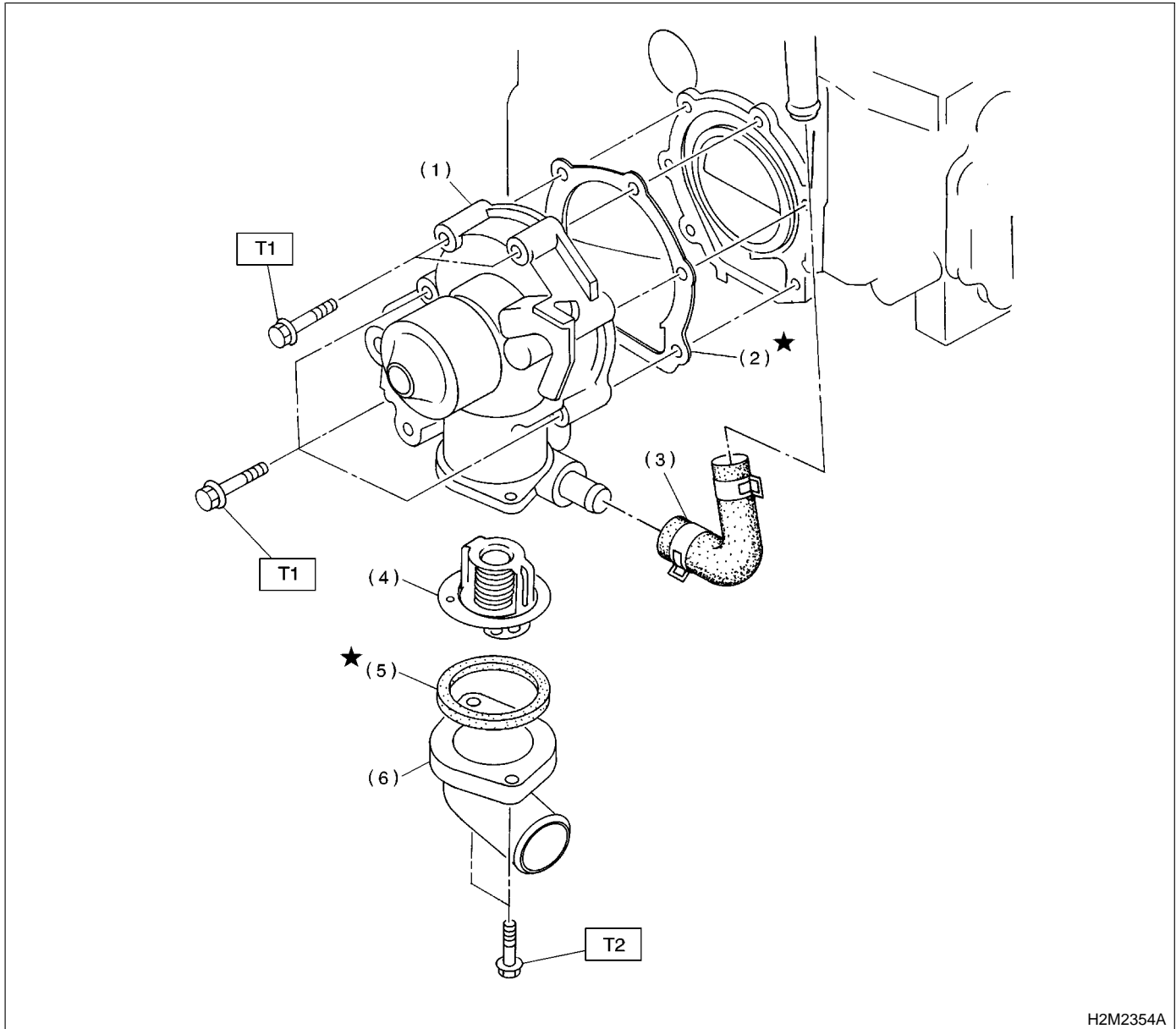

H2M2354A

- | | |
|-------------------------|----------------------|
| (1) Water pump ASSY | (5) Gasket |
| (2) Gasket | (6) Thermostat cover |
| (3) Heater by-pass hose | |
| (4) Thermostat | |

Tightening torque: N·m (kgf·m, ft·lb)

**T1: First 12 (1.2, 8.7)
Second 12 (1.2, 8.7)**

T2: 6.4 (0.65, 4.7)

GENERAL DESCRIPTION

Cooling

● TURBO MODEL

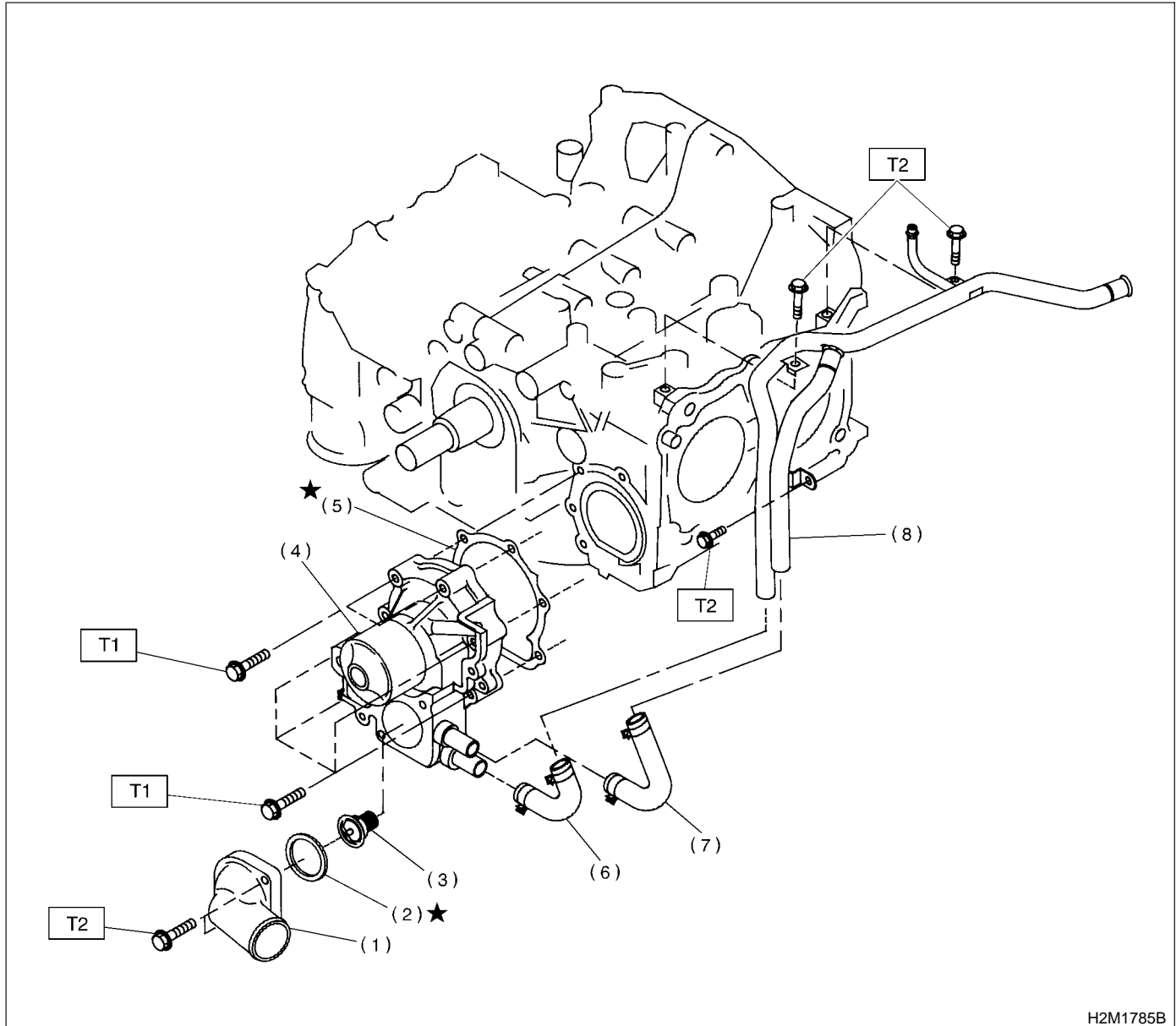

- | | |
|---------------------|--------------------------------------|
| (1) Thermostat case | (6) Header by-pass hose |
| (2) Gasket | (7) Coolant filler tank by-pass hose |
| (3) Thermostat | (8) Water by-pass pipe |
| (4) Water pump ASSY | |
| (5) Gasket | |

Tightening torque: N·m (kgf·m, ft·lb)

**T1: First 12 (1.2, 8.7)
Second 12 (1.2, 8.7)**

T2: 6.4 (0.65, 4.7)

2. RADIATOR AND RADIATOR FAN S176001A0502

● NON-TURBO MODEL

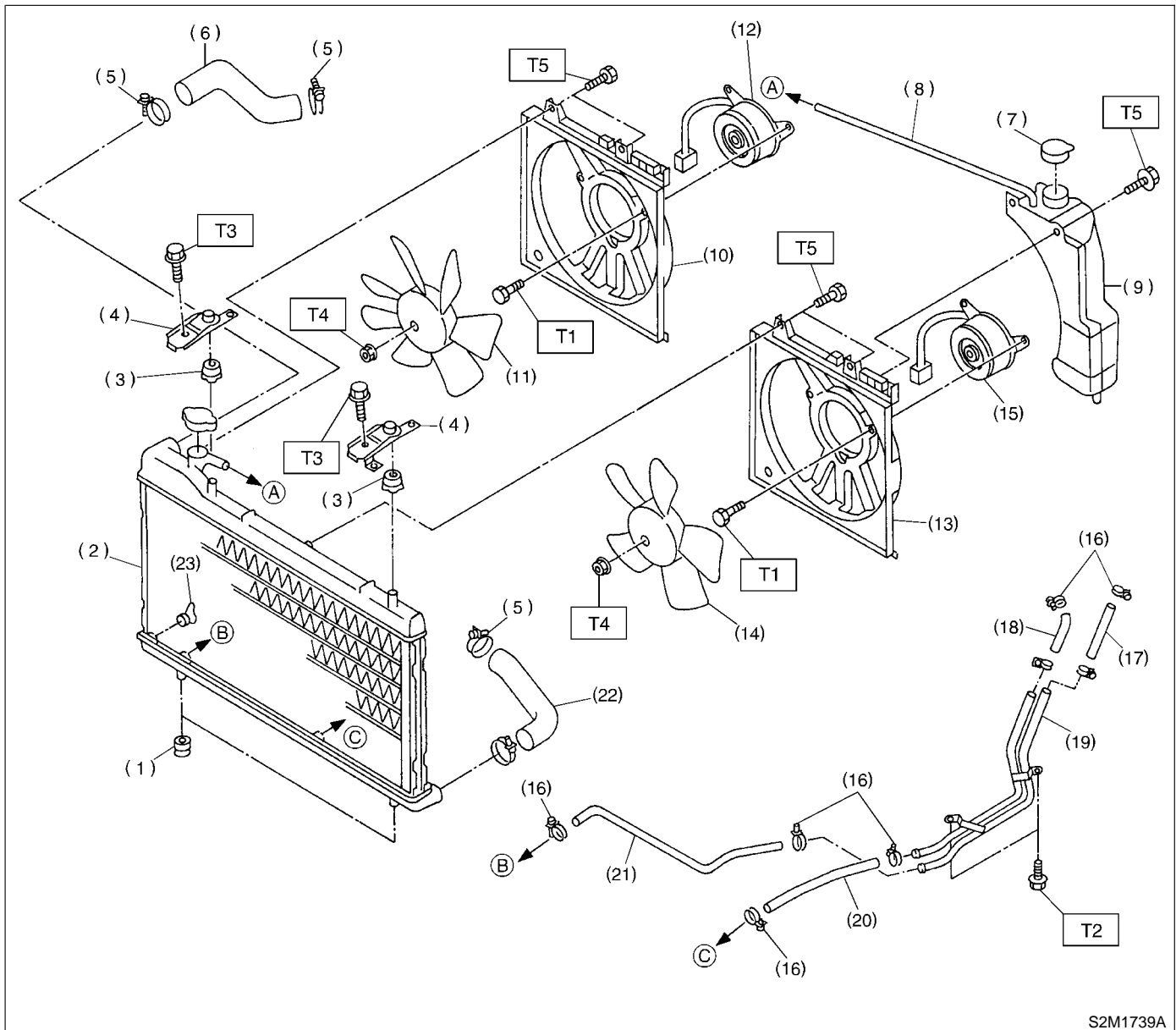

S2M1739A

- | | | |
|---------------------------------------|---|--|
| (1) Radiator lower cushion | (13) Main fan shroud | (21) ATF inlet hose B (AT vehicles only) |
| (2) Radiator | (14) Radiator main fan | (22) Radiator outlet hose |
| (3) Radiator upper cushion | (15) Radiator main fan motor | (23) Radiator drain plug |
| (4) Radiator upper bracket | (16) ATF hose clamp (AT vehicles only) | |
| (5) Clamp | (17) ATF inlet hose A (AT vehicles only) | |
| (6) Radiator inlet hose | (18) ATF outlet hose A (AT vehicles only) | |
| (7) Engine coolant reservoir tank cap | (19) ATF pipe (AT vehicles only) | |
| (8) Over flow hose | (20) ATF outlet hose B (AT vehicles only) | |
| (9) Engine coolant reservoir tank | | |
| (10) Sub fan shroud | | |
| (11) Radiator sub fan | | |
| (12) Radiator sub fan motor | | |

Tightening torque: N·m (kgf-m, ft-lb)

T1: 4.4 (0.45, 3.3)

T2: 12 (1.2, 8.7)

T3: 18 (1.8, 13.0)

T4: 3.4 (0.35, 2.5)

T5: 4.9 (0.50, 3.6)

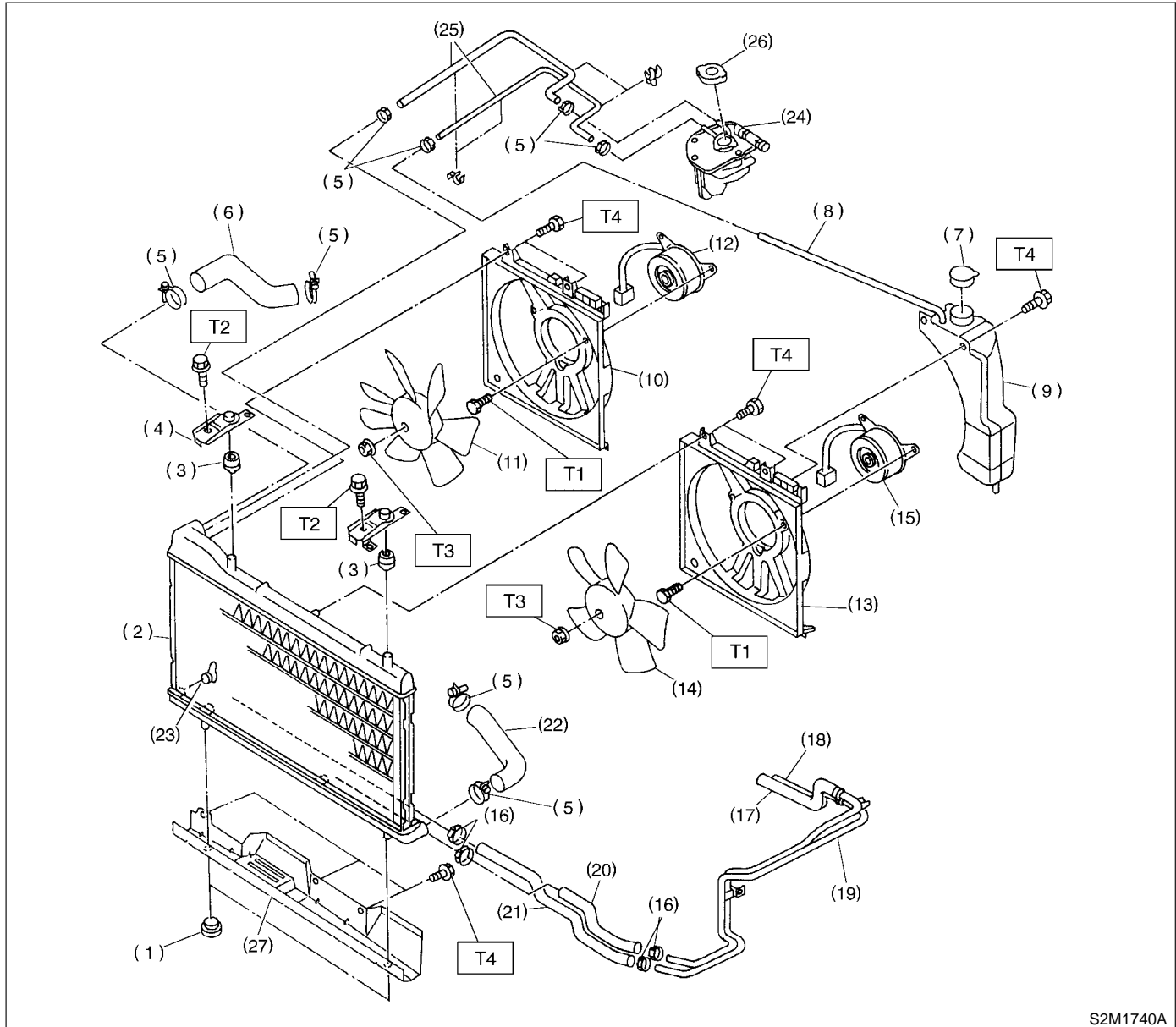
GENERAL DESCRIPTION**● TURBO MODEL**

- (1) Radiator lower cushion
- (2) Radiator
- (3) Radiator upper cushion
- (4) Radiator upper bracket
- (5) Clamp
- (6) Radiator inlet hose
- (7) Engine coolant reservoir tank cap
- (8) Over flow hose
- (9) Engine coolant reservoir tank
- (10) Sub fan shroud
- (11) Radiator sub fan

- (12) Radiator sub fan motor
- (13) Main fan shroud
- (14) Radiator main fan
- (15) Radiator main fan motor
- (16) Oil cooler hose clamp
- (17) Oil cooler inlet hose A
- (18) Oil cooler outlet hose A
- (19) Oil cooler pipe
- (20) Oil cooler outlet hose B
- (21) Oil cooler inlet hose B
- (22) Radiator outlet hose
- (23) Radiator drain plug

- (24) Engine coolant filler tank
- (25) Engine coolant hose
- (26) Engine coolant filler tank cap
- (27) Radiator under cover (AT vehicle)

Tightening torque: N·m (kgf·m, ft·lb)**T1: 4.4 (0.45, 3.3)****T2: 18 (1.8, 13.0)****T3: 3.4 (0.35, 2.5)****T4: 4.9 (0.50, 3.6)**

GENERAL DESCRIPTION

Cooling

C: CAUTION S176001A03

- Wear working clothing, including a cap, protective goggles, and protective shoes during operation.
- Remove contamination including dirt and corrosion before removal, installation or disassembly.
- Keep the disassembled parts in order and protect them from dust or dirt.
- Before removal, installation or disassembly, be sure to clarify the failure. Avoid unnecessary removal, installation, disassembly, and replacement.

- Be careful not to burn your hands, because each part in the vehicle is hot after running.
- Be sure to tighten fasteners including bolts and nuts to the specified torque.
- Place shop jacks or safety stands at the specified points.
- Before disconnecting electrical connectors of sensors or units, be sure to disconnect negative terminal from battery.

D: PREPARATION TOOL S176001A17

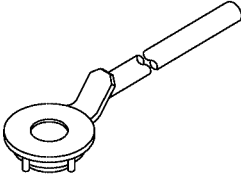
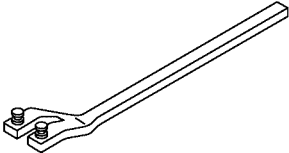
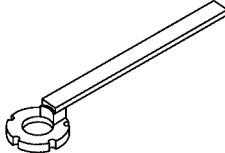
ILLUSTRATION	TOOL NUMBER	DESCRIPTION	REMARKS
 <p>B2M4157</p>	499977300	CRANK PULLEY WRENCH	Used for stopping crankshaft pulley when loosening and tightening crankshaft pulley bolts.
 <p>B2M3859</p>	499207100	CAMSHAFT SPROCKET WRENCH	Used for removing and installing camshaft sprocket. (Non-turbo LH side only)
 <p>B2M4158</p>	499207400	CAMSHAFT SPROCKET WRENCH	Used for removing and installing camshaft sprocket.

RADIATOR MAIN FAN SYSTEM

Cooling

2. Radiator Main Fan System

S176732

A: SCHEMATIC

S176732A21

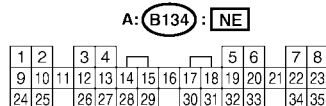
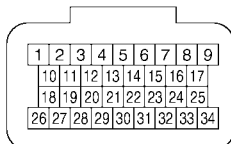
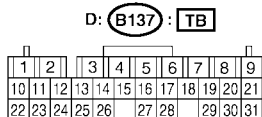
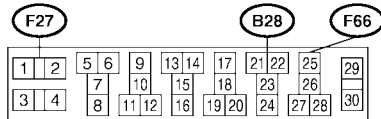
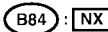
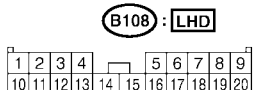
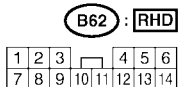
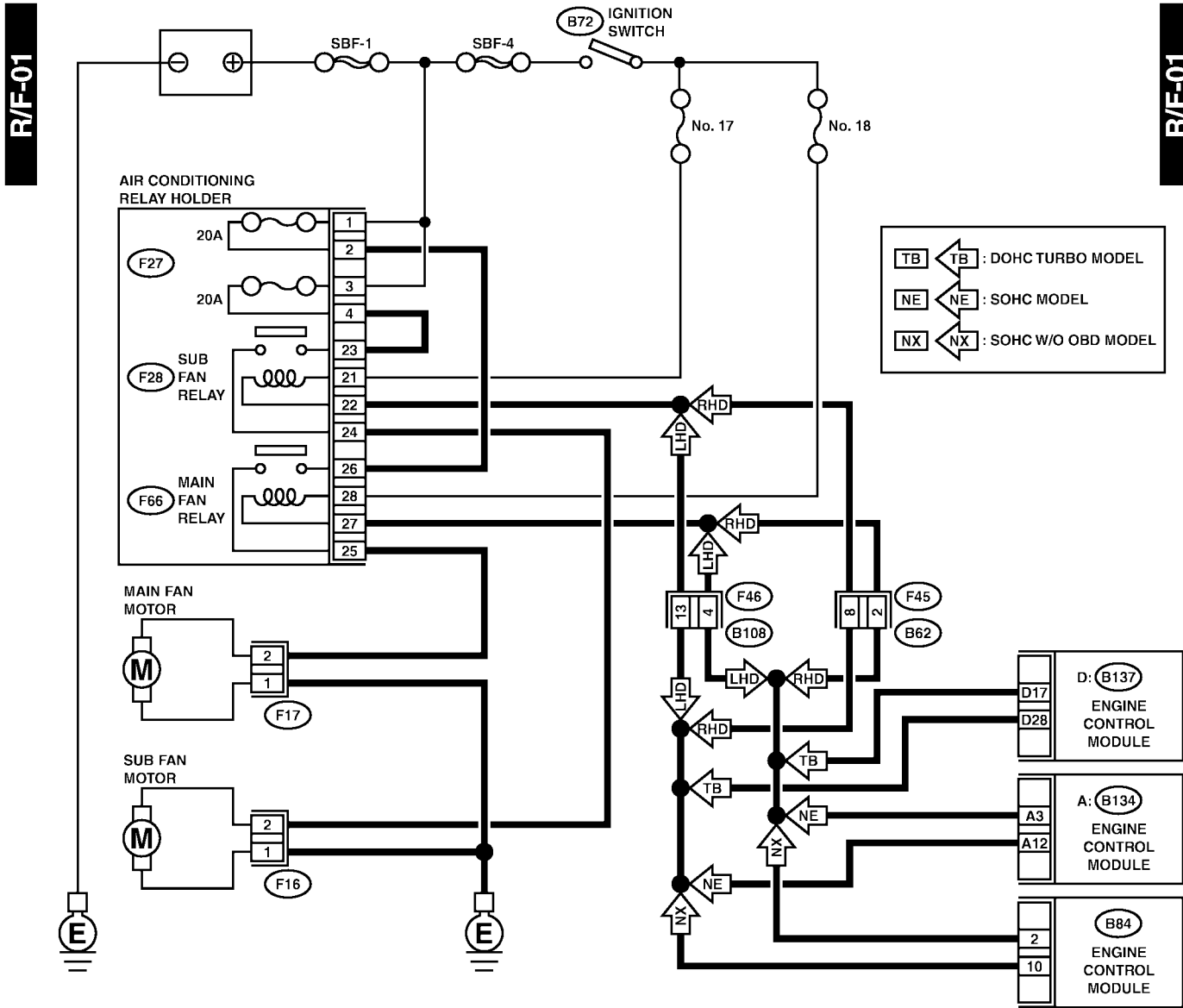

S2M2148

RADIATOR MAIN FAN SYSTEM

Cooling

B: INSPECTION S176732A10

DETECTING CONDITION:

Condition:

- Engine coolant temperature is above 95°C (203°F).

- Vehicle speed is below 19 km/h (12 MPH).

TROUBLE SYMPTOM:

- Radiator main fan does not rotate under the above conditions.

No.	Step	Check	Yes	No
1	CHECK POWER SUPPLY TO MAIN FAN MOTOR. CAUTION: Be careful not to overheat engine during repair. 1) Turn ignition switch to OFF. 2) Disconnect connector from main fan motor. 3) Start the engine, and warm it up until engine coolant temperature increases over 95°C (203°F). 4) Stop the engine and turn ignition switch to ON. 5) Measure voltage between main fan motor connector and chassis ground. Connector & terminal (F17) No. 2 (+) — Chassis ground (-):	Is the voltage more than 10 V?	Go to step 2.	Go to step 5.
2	CHECK GROUND CIRCUIT OF MAIN FAN MOTOR. 1) Turn ignition switch to OFF. 2) Measure resistance between main fan motor connector and chassis ground. Connector & terminal (F17) No. 1 — Chassis ground:	Is the resistance less than 5 Ω?	Go to step 3.	Repair open circuit in harness between main fan motor connector and chassis ground.
3	CHECK POOR CONTACT. Check poor contact in main fan motor connector.	Is there poor contact in main fan motor connector?	Repair poor contact in main fan motor connector.	Go to step 4.
4	CHECK MAIN FAN MOTOR. Connect battery positive (+) terminal to terminal No. 2, and negative (-) terminal to terminal No. 1 of main fan motor connector.	Does the main fan rotate?	Repair poor contact in main fan motor connector.	Replace main fan motor with a new one.
5	CHECK POWER SUPPLY TO MAIN FAN RELAY. 1) Turn ignition switch to OFF. 2) Remove main fan relay from A/C relay holder. 3) Measure voltage between main fan relay terminal and chassis ground. Connector & terminal (F66) No. 26 (+) — Chassis ground (-):	Is the voltage more than 10 V?	Go to step 6.	Go to step 7.
6	CHECK POWER SUPPLY TO MAIN FAN RELAY. 1) Turn ignition switch to ON. 2) Measure voltage between main fan relay terminal and chassis ground. Connector & terminal (F66) No. 28 (+) — Chassis ground (-):	Is the voltage more than 10 V?	Go to step 10.	Go to step 9.
7	CHECK 20 A FUSE. 1) Remove 20 A fuse from A/C relay holder. 2) Check condition of fuse.	Is the fuse blown-out?	Replace fuse.	Go to step 8.

RADIATOR MAIN FAN SYSTEM

Cooling

No.	Step	Check	Yes	No
8	CHECK POWER SUPPLY TO A/C RELAY HOLDER 20 A FUSE TERMINAL. Measure voltage of harness between A/C relay holder 20 A fuse terminal and chassis ground. <i>Connector & terminal</i> <i>(F27) No. 1 (+) — Chassis ground (-):</i>	Is the voltage more than 10 V?	Repair open circuit in harness between 20 A fuse and main fan relay terminal.	Repair open circuit in harness between main fuse box connector and 20 A fuse terminal.
9	CHECK FUSE. 1) Turn ignition switch to OFF. 2) Remove fuse No. 18 from joint box. 3) Check condition of fuse.	Is the fuse blown-out?	Replace fuse.	Repair open circuit in harness between main fan relay and ignition switch.
10	CHECK MAIN FAN RELAY. 1) Turn ignition switch to OFF. 2) Remove main fan relay. 3) Measure resistance of main fan relay. <i>Terminal</i> <i>No. 26 — No. 25:</i>	Is the resistance more than 1 M Ω ?	Go to step 11.	Replace main fan relay.
11	CHECK MAIN FAN RELAY. 1) Connect battery to terminals No. 27 and No. 28 of main fan relay. 2) Measure resistance of main fan relay. <i>Terminal</i> <i>No. 26 — No. 25:</i>	Is the resistance less than 1 Ω ?	Go to step 12.	Replace main fan relay.
12	CHECK HARNESS BETWEEN MAIN FAN RELAY TERMINAL AND MAIN FAN MOTOR CONNECTOR. Measure resistance of harness between main fan motor connector and main fan relay terminal. <i>Connector & terminal</i> <i>(F17) No. 2 — (F66) No. 25:</i>	Is the resistance less than 1 Ω ?	Go to step 13.	Repair open circuit in harness between main fan motor connector and main fan relay terminal.
13	CHECK HARNESS BETWEEN MAIN FAN RELAY AND ECM. 1) Turn ignition switch to OFF. 2) Disconnect connector from ECM. 3) Measure resistance of harness between main fan relay connector and ECM connector. <i>Connector & terminal</i> <i>(F66) No. 27 — (B134) No. 3 (SOHC MODEL):</i> <i>(F66) No. 27 — (B84) No. 2 (SOHC w/o OBD MODEL):</i> <i>(F66) No. 27 — (B137) No. 17 (DOHC TURBO MODEL):</i>	Is the resistance less than 1 Ω ?	Go to step 14.	Repair open circuit in harness between main fan relay and ECM.
14	CHECK POOR CONTACT. Check poor contact in connector between main fan and ECM.	Is there poor contact in connector between main fan motor and ECM?	Repair poor contact connector.	Contact your Subaru distributor.

NOTE:

Inspection by your Subaru distributor is required, because probable cause is deterioration of multiple parts.

3. Radiator Sub Fan System S176733

A: SCHEMATIC S176733A21

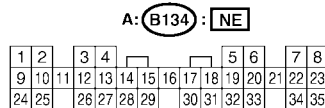
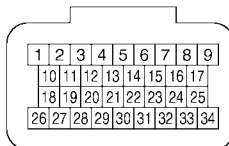
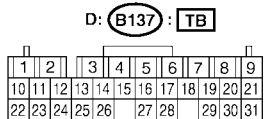
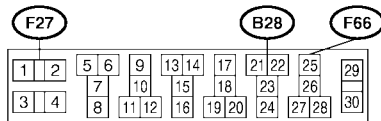
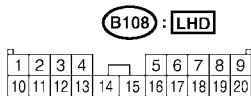
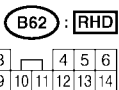
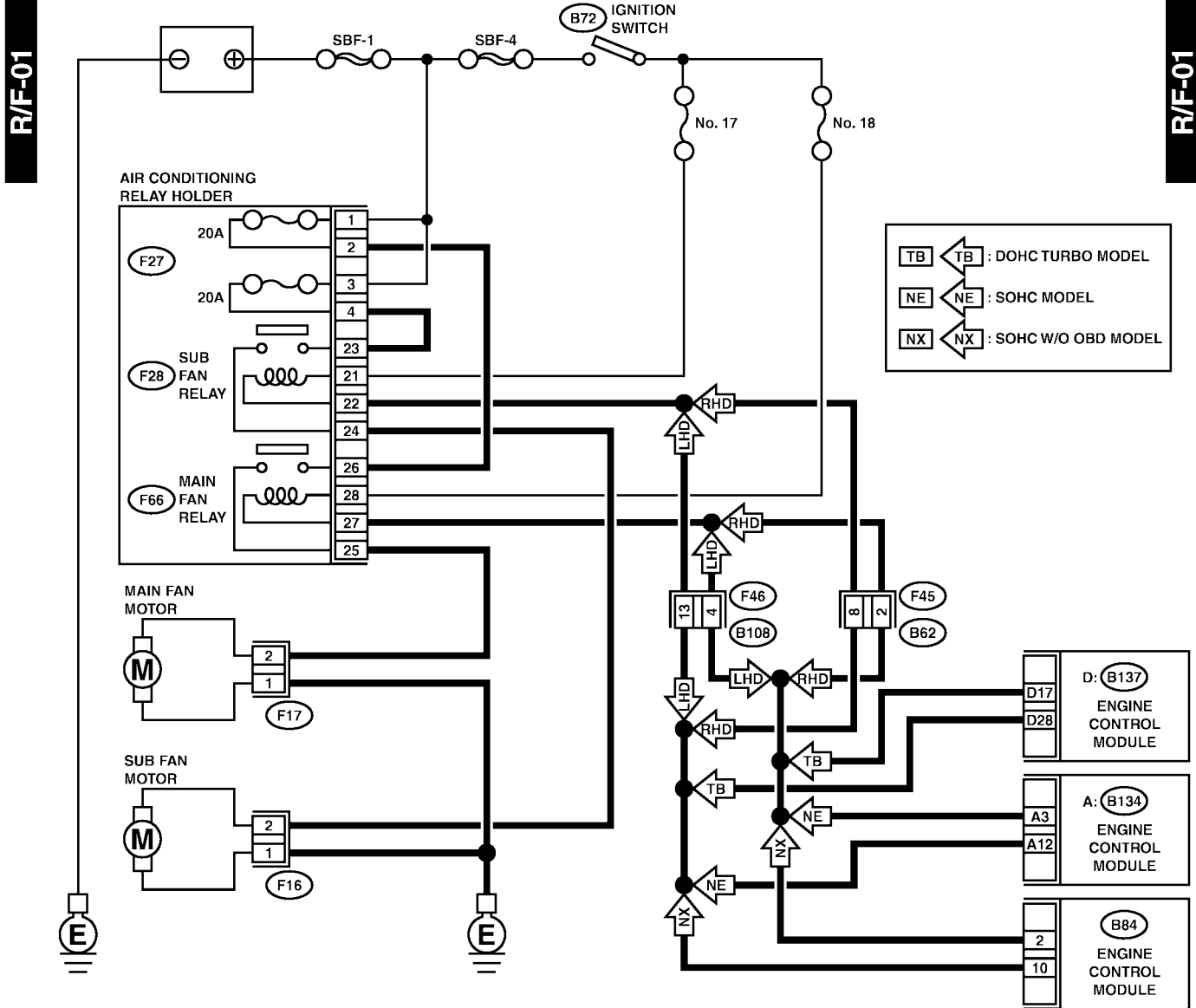

RADIATOR SUB FAN SYSTEM

Cooling

B: INSPECTION S176733A10

NOTE:

System for A/C equipped vehicles only.

DETECTING CONDITION:

Condition (1):

- Engine coolant temperature is below 95°C (203°F).
- A/C switch is turned ON.

- Vehicle speed is below 19 km/h (12 MPH).

Condition (2):

- Engine coolant temperature is above 100°C (212°F).
- A/C switch is turned OFF.
- Vehicle speed is below 19 km/h (12 MPH).

TROUBLE SYMPTOM:

- Radiator sub fan does not rotate under conditions (1) and (2) above.

No.	Step	Check	Yes	No
1	CHECK POWER SUPPLY TO SUB FAN MOTOR. CAUTION: Be careful not to overheat engine during repair. 1) Turn ignition switch to OFF. 2) Disconnect connector from sub fan motor and main fan motor. 3) Start the engine, and warm it up until engine coolant temperature increases over 100°C (212°F). 4) Stop the engine and turn ignition switch to ON. 5) Measure voltage between sub fan motor connector and chassis ground. Connector & terminal (F16) No. 2 (+) — Chassis ground (-):	Is the voltage more than 10 V?	Go to step 2.	Go to step 5.
2	CHECK GROUND CIRCUIT OF SUB FAN MOTOR. 1) Turn ignition switch to OFF. 2) Measure resistance between sub fan motor connector and chassis ground. Connector & terminal (F16) No. 1 — Chassis ground:	Is the resistance less than 5 Ω?	Go to step 3.	Repair open circuit in harness between sub fan motor connector and chassis ground.
3	CHECK POOR CONTACT. Check poor contact in sub fan motor connector.	Is there poor contact in sub fan motor connector?	Repair poor contact in sub fan motor connector.	Go to step 4.
4	CHECK SUB FAN MOTOR. Connect battery positive (+) terminal to terminal No. 2, and negative (-) terminal to terminal No. 1 of sub fan motor connector.	Does the sub fan rotate?	Repair poor contact in sub fan motor connector.	Replace sub fan motor with a new one.
5	CHECK POWER SUPPLY TO SUB FAN RELAY. 1) Turn ignition switch to OFF. 2) Remove sub fan relay from A/C relay holder. 3) Measure voltage between sub fan relay terminal and chassis ground. Connector & terminal (F28) No. 23 (+) — Chassis ground (-):	Is the voltage more than 10 V?	Go to step 6.	Go to step 7.
6	CHECK POWER SUPPLY TO SUB FAN RELAY. 1) Turn ignition switch to ON. 2) Measure voltage between sub fan relay terminal and chassis ground. Connector & terminal (F28) No. 21 (+) — Chassis ground (-):	Is the voltage more than 10 V?	Go to step 10.	Go to step 9.

RADIATOR SUB FAN SYSTEM

Cooling

No.	Step	Check	Yes	No
7	CHECK 20 A FUSE. 1) Remove 20 A fuse from A/C relay holder. 2) Check condition of fuse.	Is the fuse blown-out?	Replace fuse.	Go to step 8.
8	CHECK POWER SUPPLY TO A/C RELAY HOLDER 20 A FUSE TERMINAL. Measure voltage of harness between A/C relay holder 20 A fuse terminal and chassis ground. <i>Connector & terminal (F27) No. 3 (+) — Chassis ground (-):</i>	Is the voltage more than 10 V?	Repair open circuit in harness between 20 A fuse and sub fan relay terminal.	Repair open circuit in harness between main fuse box connector and 20 A fuse terminal.
9	CHECK FUSE. 1) Turn ignition switch to OFF. 2) Remove fuse No. 17 from joint box. 3) Check condition of fuse.	Is the fuse blown-out?	Replace fuse.	Repair open circuit in harness between sub fan relay and ignition switch.
10	CHECK SUB FAN RELAY. 1) Turn ignition switch to OFF. 2) Measure resistance of sub fan relay. <i>Terminal No. 23 — No. 24:</i>	Is the resistance more than 1 MΩ?	Go to step 11.	Replace sub fan relay.
11	CHECK SUB FAN RELAY. 1) Connect battery to terminals No. 21 and No. 22 of sub fan relay. 2) Measure resistance of sub fan relay. <i>Terminal No. 23 — No. 24:</i>	Is the resistance less than 1 Ω?	Go to step 12.	Replace sub fan relay.
12	CHECK HARNESS BETWEEN SUB FAN RELAY TERMINAL AND SUB FAN MOTOR CONNECTOR. Measure resistance of harness between sub fan motor connector and sub fan relay terminal. <i>Connector & terminal (F16) No. 2 — (F28) No. 24:</i>	Is the resistance less than 1 Ω?	Go to step 13.	Repair open circuit in harness between sub fan motor and sub fan relay connector.
13	CHECK HARNESS BETWEEN SUB FAN RELAY AND ECM. 1) Turn ignition switch to OFF. 2) Disconnect connector from ECM. 3) Measure resistance of harness between sub fan relay connector and ECM connector. <i>Connector & terminal (F28) No. 22 — (B134) No. 12 (SOHC MODEL): (F28) No. 22 — (B84) No. 10 (SOHC w/o OBD MODEL): (F28) No. 22 — (B137) No. 28 (DOHC TURBO MODEL):</i>	Is the resistance less than 1 Ω?	Go to step 14.	Repair open circuit in harness between sub fan relay and ECM.
14	CHECK POOR CONTACT. Check poor contact in connector between sub fan and ECM.	Is there poor contact in connector between sub fan motor and ECM?	Repair poor contact connector.	Contact your Subaru distributor.

NOTE:

Inspection by your Subaru distributor is required, because probable cause is deterioration of multiple parts.

ENGINE COOLANT

Cooling

4. Engine Coolant S176060

A: REPLACEMENT S176060A20

1. DRAINING OF ENGINE COOLANT

S176060A2001

- 1) Lift-up the vehicle.
- 2) Remove under cover.
- 3) Remove drain cock to drain engine coolant into container.

NOTE:

Remove radiator cap so that engine coolant will drain faster.

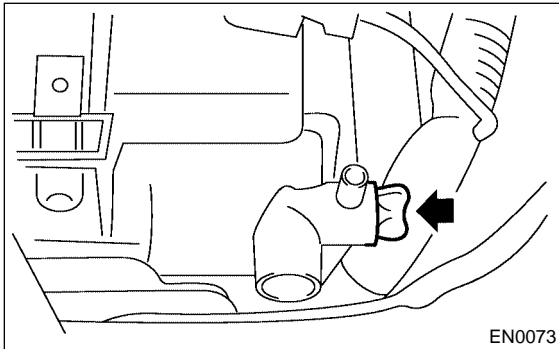

2. FILLING OF ENGINE COOLANT S176060A2002

- 1) Fill engine coolant into radiator up to filler neck position.

Coolant capacity (fill up to "FULL" level):

Non-turbo AT model

Approx. 6.4 ℓ (6.8 US qt, 5.6 Imp qt)

Non-turbo MT model

Approx. 6.3 ℓ (6.7 US qt, 5.5 Imp qt)

Turbo model

Approx. 7.2 ℓ (7.6 US qt, 6.3 Imp qt)

CAUTION:

The SUBARU Genuine Coolant containing anti-freeze and anti-rust agents is especially made for SUBARU engine, which has an aluminum crankcase. Always use SUBARU Genuine Coolant, since other coolant may cause corrosion.

- 2) Fill engine coolant into reservoir tank up to upper level.

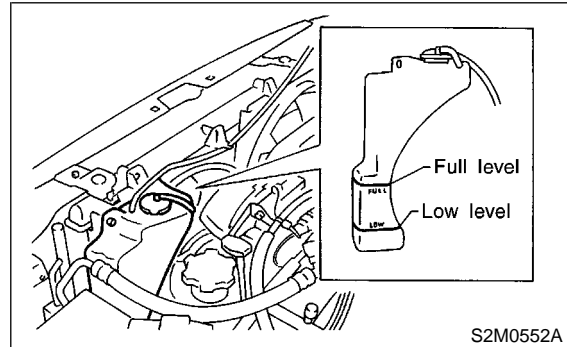

- 3) Warm-up engine completely for more than five minutes at 2,000 to 3,000 rpm.
- 4) If engine coolant level drops in radiator, add engine coolant to filler neck position.
- 5) If engine coolant level drops from upper level of reservoir tank, add engine coolant to upper level.
- 6) Attach radiator cap and reservoir tank cap properly.

B: INSPECTION S176060A10

1. RELATIONSHIP OF SUBARU COOLANT CONCENTRATION AND FREEZING TEMPERATURE S176060A1001

The concentration and safe operating temperature of the SUBARU coolant is shown in the diagram. Measuring the temperature and specific gravity of the coolant will provide this information.

[Example]

If the coolant temperature is 25°C (77°F) and its specific gravity is 1.054, the concentration is 35% (point A), the safe operating temperature is -14°C (7°F) (point B), and the freezing temperature is -20°C (-4°F) (point C).

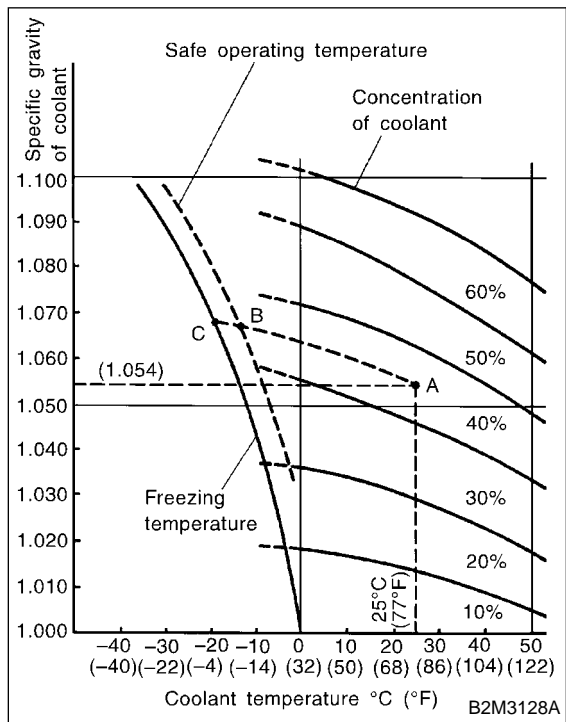

2. PROCEDURE TO ADJUST THE CONCENTRATION OF THE COOLANT

S176060A1002

To adjust the concentration of the coolant according to temperature, find the proper fluid concentration in the above diagram and replace the necessary amount of coolant with an undiluted solution of SUBARU genuine coolant (concentration 50%). The amount of coolant that should be replaced can be determined using the diagram.

[Example]

Assume that the coolant concentration must be increased from 25% to 40%. Find point A, where the 25% line of coolant concentration intersects with the 40% curve of the necessary coolant concentration, and read the scale on the vertical axis of the graph at height A. The quantity of coolant to be drained is 2.1 liters (2.2 US qt, 1.8 Imp qt). Drain 2.1 liters (2.2 US qt, 1.8 Imp qt) of coolant from the cooling system and add 2.1 liters (2.2 US qt, 1.8 Imp qt) of the undiluted solution of SUBARU coolant.

If a coolant concentration of 50% is needed, drain all the coolant and refill with the undiluted solution only.

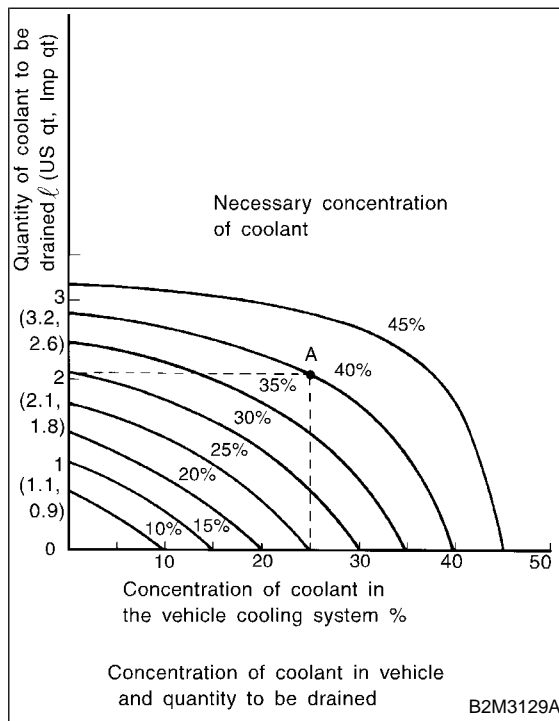

5. Water Pump S176061

A: REMOVAL S176061A18

1. NON-TURBO MODEL S176061A1801

1) Disconnect ground cable from the battery.

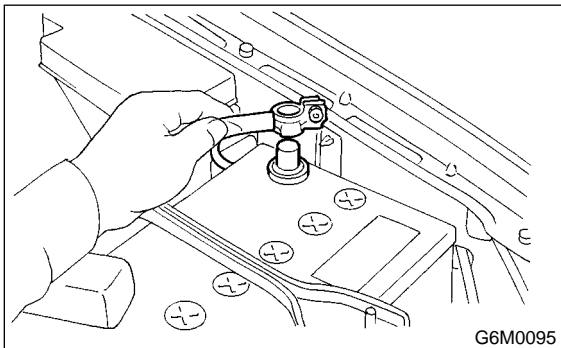

2) Lift-up the vehicle.

3) Remove under cover.

4) Drain engine coolant completely.

<Ref. to CO-14, DRAINING OF ENGINE COOLANT, REPLACEMENT, Engine Coolant.>

5) Disconnect connectors from radiator main fan (A) and sub fan (B) motors.

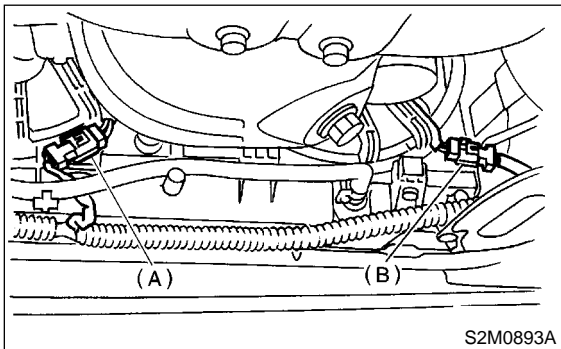

6) Disconnect radiator outlet hose and heater hose from water pump.

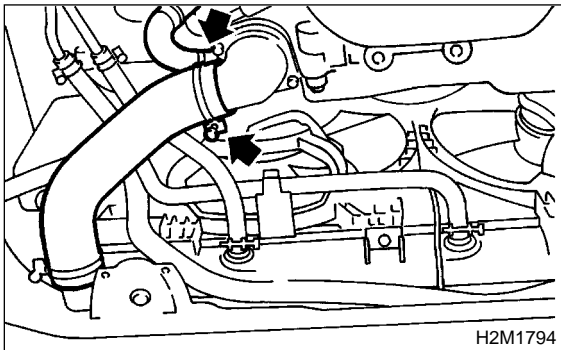

7) Lower the vehicle.

8) Disconnect over flow hose.

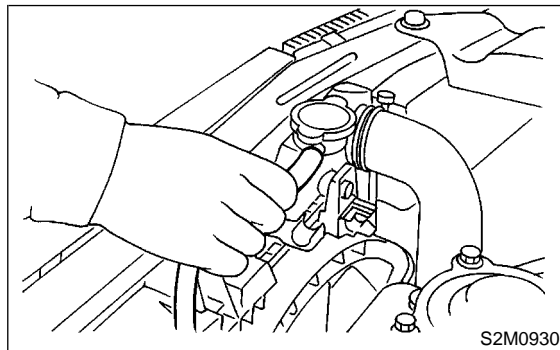

9) Remove reservoir tank.

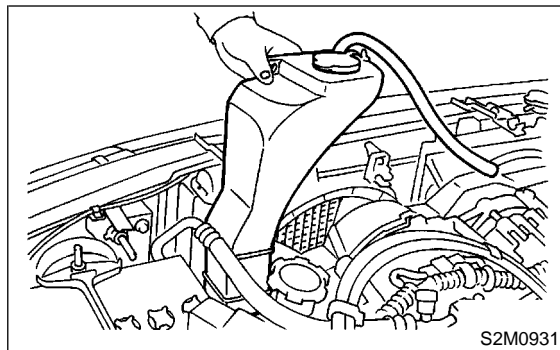

10) Remove radiator main fan and sub fan assemblies. <Ref. to CO-32, REMOVAL, Radiator Main Fan and Fan Motor.> and <Ref. to CO-34, REMOVAL, Radiator Sub Fan and Fan Motor.>

11) Remove V-belts.

<Ref. to ME(SOHC)-42, REMOVAL, V-belt.>

12) Remove timing belt.

<Ref. to ME(SOHC)-46, TIMING BELT, REMOVAL, Timing Belt Assembly.>

13) Remove automatic belt tension adjuster.

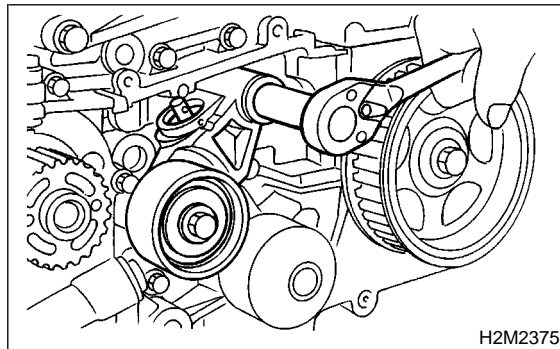

14) Remove belt idler No. 2.

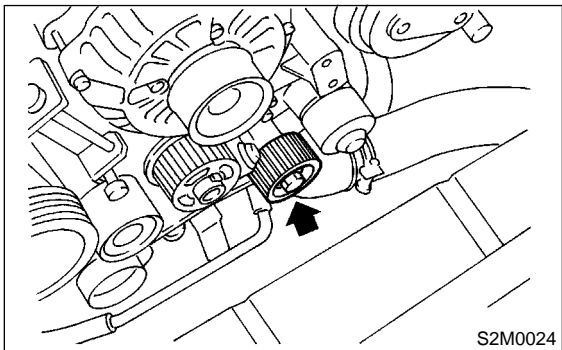

15) Remove left-hand camshaft sprocket by using ST.
ST 499207100 CAMSHAFT SPROCKET WRENCH

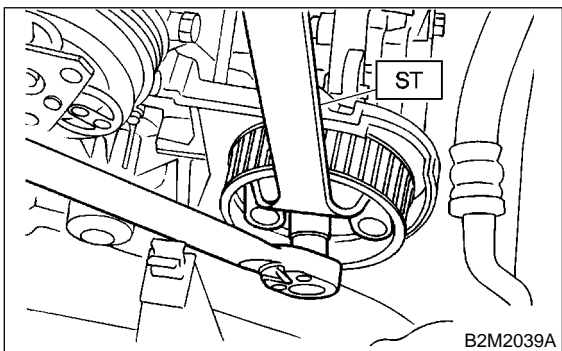

16) Remove left-hand belt cover No. 2.

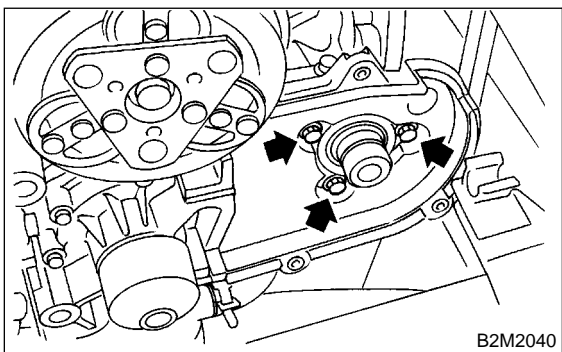

17) Remove tensioner bracket.

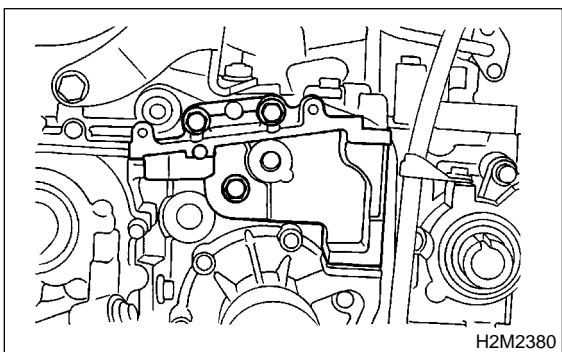

18) Disconnect heater hose from water pump.

19) Remove water pump.

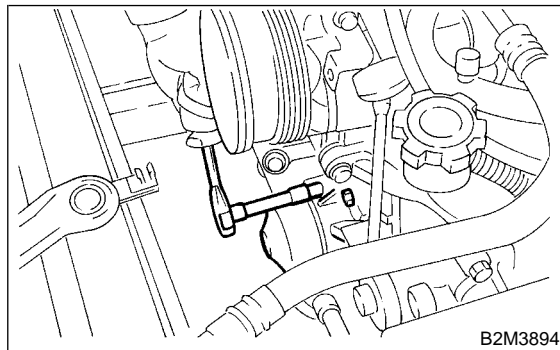

2. TURBO MODEL S176061A1802

WARNING:
The radiator is pressurized. Wait until engine cools down before working on the radiator.

- 1) Set the vehicle on the lift.
- 2) Disconnect ground cable from the battery.

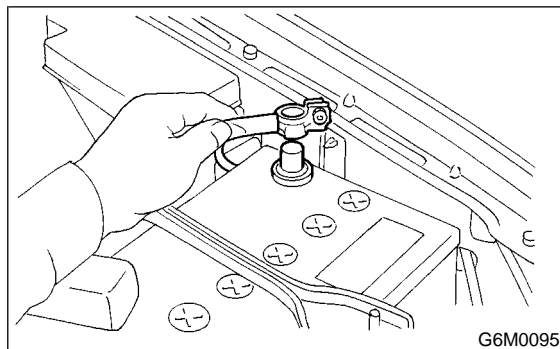

- 3) Lift-up the vehicle.
- 4) Remove under cover.
- 5) Drain engine coolant completely. <Ref. to CO-14, DRAINING OF ENGINE COOLANT, REPLACEMENT, Engine Coolant.>
- 6) Disconnect connectors from radiator main fan and sub fan motors.
- 7) Remove bolt which installs water by-pass pipe of oil cooler onto oil pump.

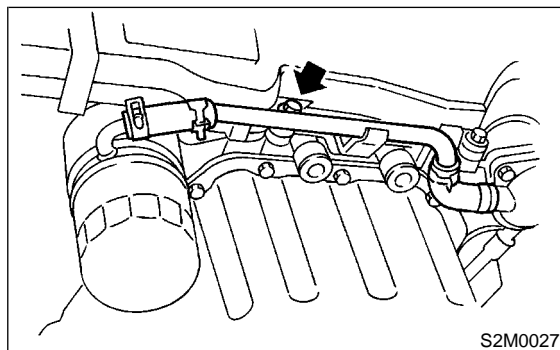

8) Disconnect radiator outlet hose (A) and heater hose (B) from water pump.

WATER PUMP

Cooling

9) Disconnect water by-pass hose (C) and oil cooler hose (D).

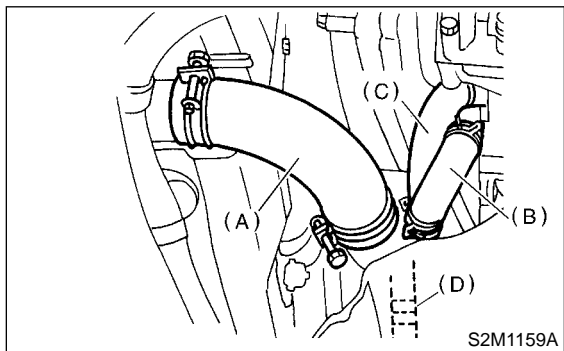

- 10) Lower the vehicle.
- 11) Disconnect over flow hose.
- 12) Remove reservoir tank.

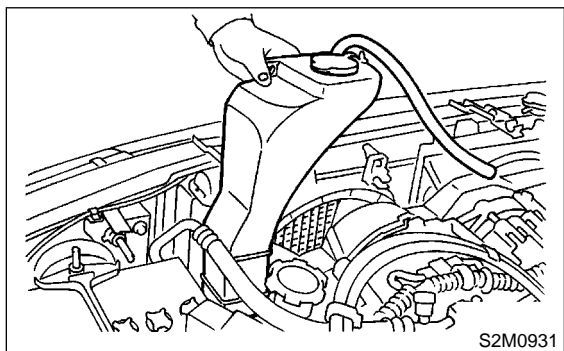

- 13) Remove radiator main fan and sub fan assemblies. <Ref. to CO-32, REMOVAL, Radiator Main Fan and Fan Motor.> and <Ref. to CO-34, REMOVAL, Radiator Sub Fan and Fan Motor.>
- 14) Remove V-belts. <Ref. to ME(DOHC TURBO)-44, REMOVAL, V-belt.>
- 15) Remove timing belt. <Ref. to ME(DOHC TURBO)-48, REMOVAL, Timing Belt Assembly.>
- 16) Remove automatic belt tension adjuster (A).
- 17) Remove belt idler (B).
- 18) Remove belt idler No. 2 (C).

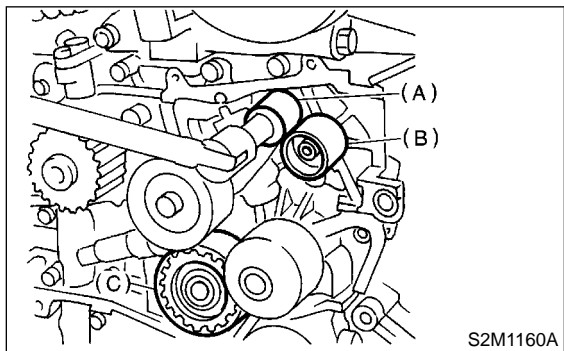

19) Remove camshaft position sensor. <Ref. to FU(DOHC TURBO)-31, REMOVAL, Camshaft Position Sensor.>

20) Remove left-hand camshaft sprockets by using ST.
ST 499207400 CAMSHAFT SPROCKET WRENCH

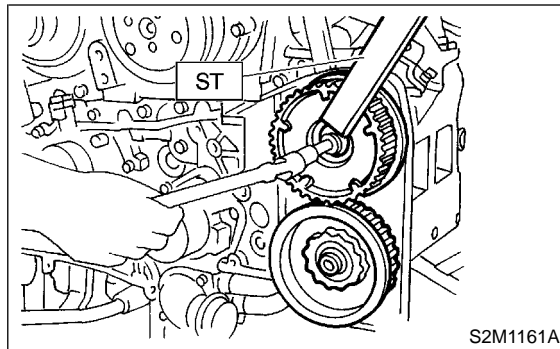

21) Remove left-hand belt cover No. 2.

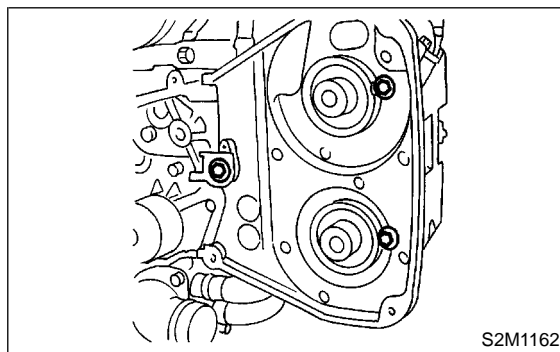

22) Remove tensioner bracket.

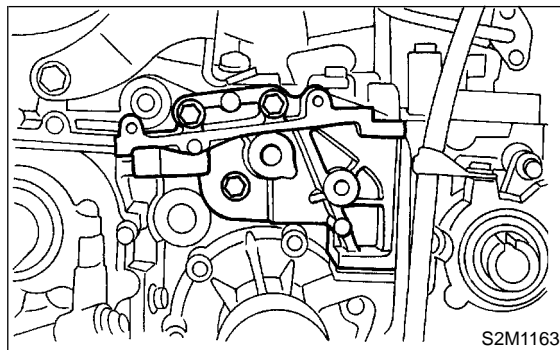

- 23) Disconnect heater hose from water pump.
- 24) Remove water pump.

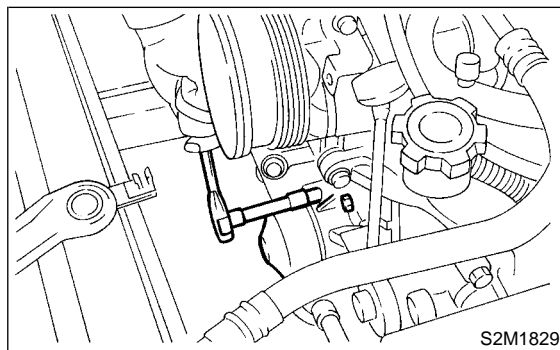

B: INSTALLATION S176061A11

1. NON-TURBO MODEL S176061A1101

1) Install water pump onto left-hand cylinder head.

CAUTION:

- Replace gasket with a new one.
- When installing water pump, tighten bolts in two stages in alphabetical sequence as shown in figure.

Tightening torque:

First:

12 N·m (1.2 kgf·m, 8.7 ft·lb)

Second:

12 N·m (1.2 kgf·m, 8.7 ft·lb)

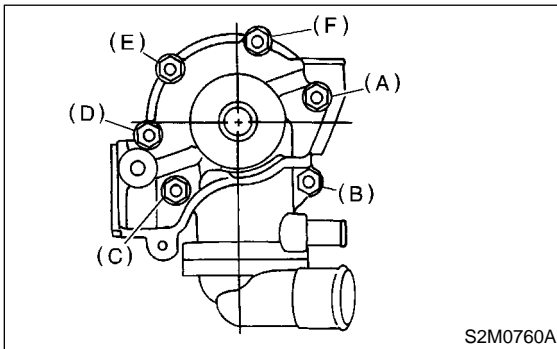

2) Install left-hand belt cover No. 2.

Tightening torque:

5 N·m (0.5 kgf·m, 3.6 ft·lb)

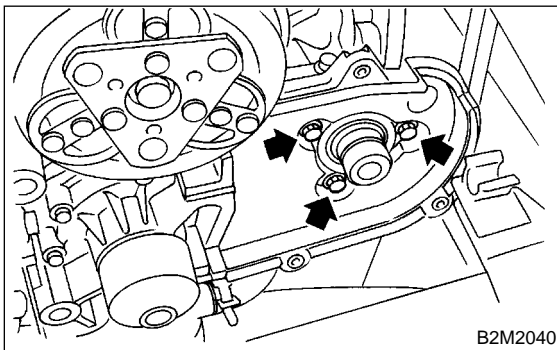

3) Install tensioner bracket.

Tightening torque:

25 N·m (2.5 kgf·m, 18.1 ft·lb)

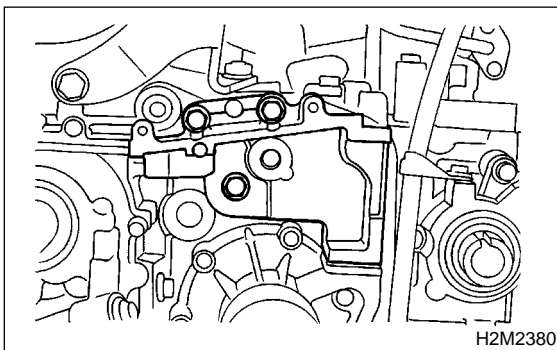

4) Install left-hand camshaft sprockets by using ST.

ST 4992707100 CAMSHAFT SPROCKET
WRENCH

Tightening torque:

78 N·m (8.0 kgf·m, 57.9 ft·lb)

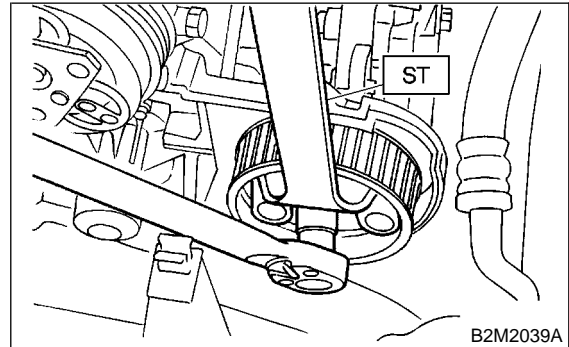

5) Install belt idler No. 2.

Tightening torque:

39 N·m (4.0 kgf·m, 28.9 ft·lb)

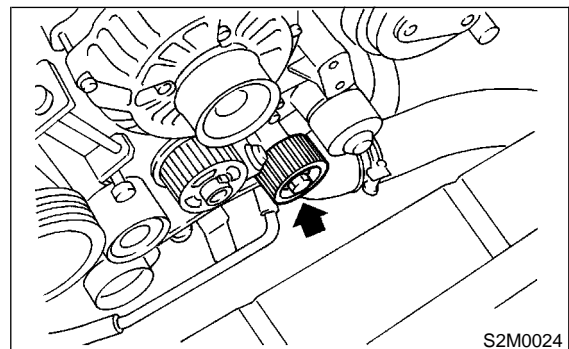

6) Install automatic belt tension adjuster which tension rod is held with pin. <Ref. to ME(SOHC)-47, AUTOMATIC BELT TENSION ADJUSTER ASSEMBLY AND BELT IDLER, INSTALLATION, Timing Belt Assembly.>

7) Install timing belt. <Ref. to ME(SOHC)-48, TIMING BELT, INSTALLATION, Timing Belt Assembly.>

8) Install V-belts. <Ref. to ME(SOHC)-42, INSTALLATION, V-belt.>

9) Install radiator main fan and sub fan motor assemblies. <Ref. to CO-32, INSTALLATION, Radiator Main Fan and Fan Motor.> and <Ref. to CO-34, INSTALLATION, Radiator Sub Fan and Fan Motor.>

WATER PUMP

Cooling

10) Install reservoir tank.

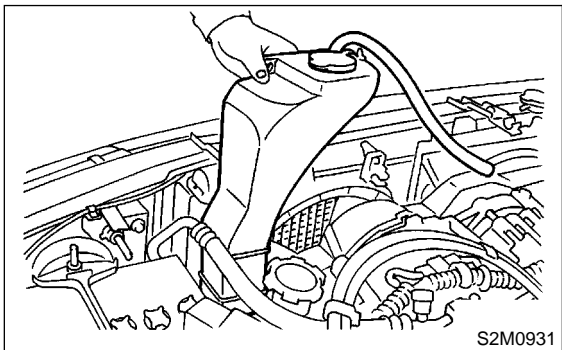

11) Connect over flow hose.

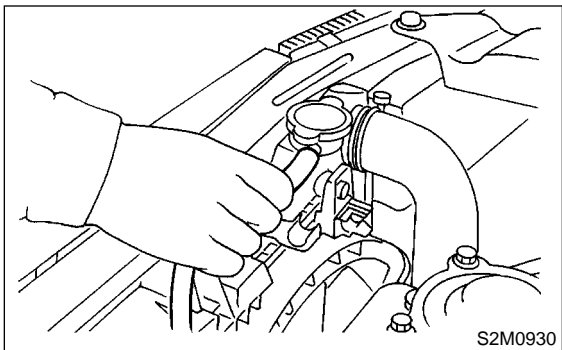

12) Lift-up the vehicle.

13) Connect radiator outlet hose and heater hose to water pump.

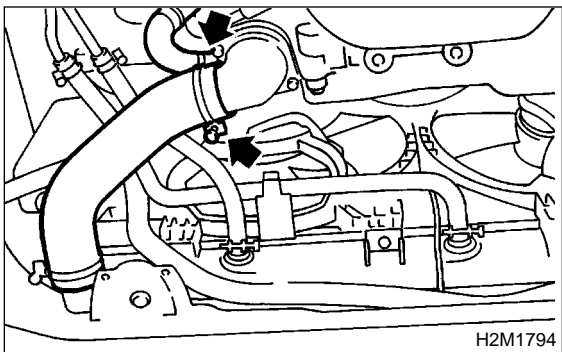

14) Connect connectors to radiator main fan (A) and sub fan (B) motors.

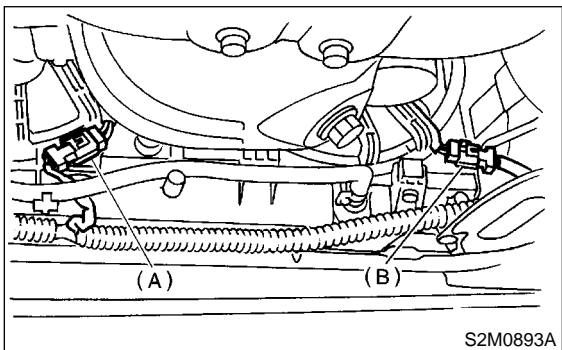

15) Install under cover.

16) Lower the vehicle.

17) Connect battery ground cable.

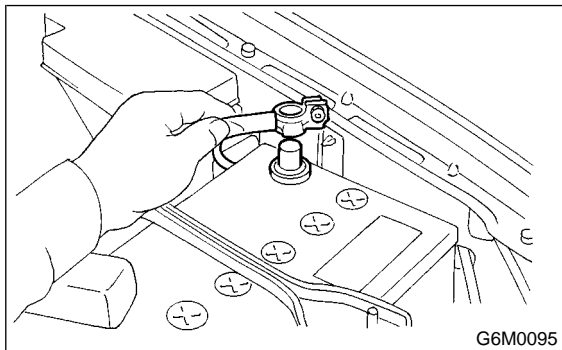

18) Fill coolant. <Ref. to CO-14, FILLING OF ENGINE COOLANT, REPLACEMENT, Engine Coolant.>

2. TURBO MODEL S176061A1102

1) Install water pump onto left-hand cylinder head.

CAUTION:

- Replace gasket with a new one.
- When installing water pump, tighten bolts in two stages in alphabetical sequence as shown in figure.

Tightening torque:

First:

12 N-m (1.2 kgf-m, 8.7 ft-lb)

Second:

12 N-m (1.2 kgf-m, 8.7 ft-lb)

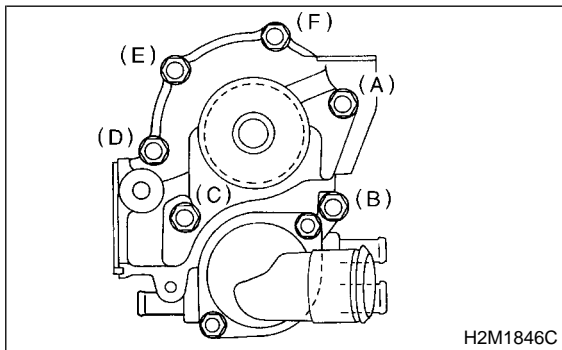

2) Install left-hand belt cover No. 2.

Tightening torque:

5 N-m (0.5 kgf-m, 3.6 ft-lb)

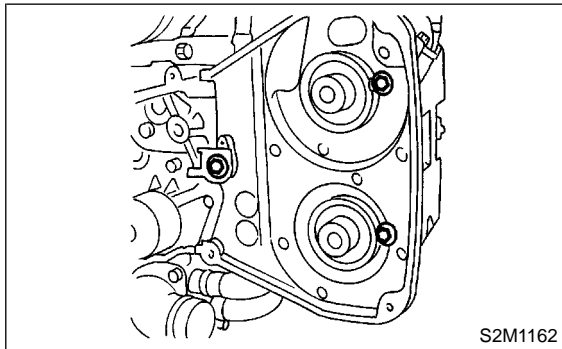

3) Install tensioner bracket.

Tightening torque:

25 N·m (2.5 kgf·m, 18.1 ft·lb)

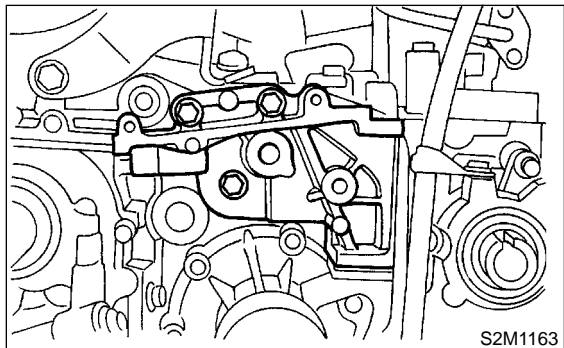

4) Install left-hand camshaft sprockets by using ST.

ST 499207400 CAMSHAFT SPROCKET WRENCH

Tightening torque:

98 N·m (10.0 kgf·m, 72.4 ft·lb)

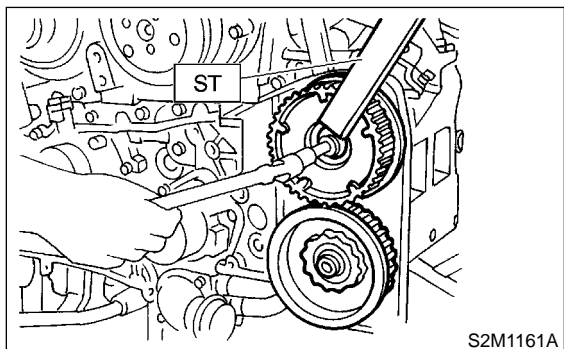

5) Install camshaft position sensor. <Ref. to FU(DOHC TURBO)-31, INSTALLATION, Camshaft Position Sensor.>

6) Install belt idler No. 2 (C).

7) Install belt idler (B).

8) Install automatic belt tension adjuster (A) which has a tension rod held by a pin. <Ref. to ME(DOHC TURBO)-49, AUTOMATIC BELT TENSION ADJUSTER ASSEMBLY AND BELT IDLER, INSTALLATION, Timing Belt Assembly.>

Tightening torque:

39.4 N·m (4.0 kgf·m, 28.9 ft·lb)

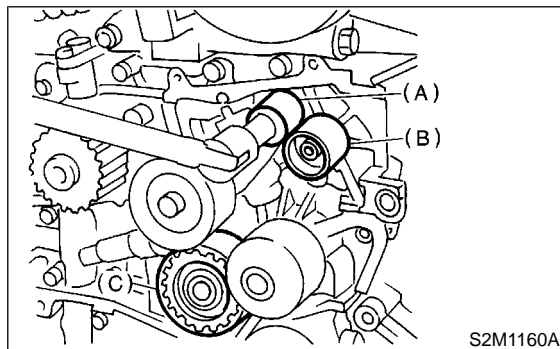

9) Install timing belt. <Ref. to ME(DOHC TURBO)-50, TIMING BELT, INSTALLATION, Timing Belt Assembly.>

10) Install V-belts. <Ref. to ME(DOHC TURBO)-44, INSTALLATION, V-belt.>

11) Install radiator main fan and sub fan motor assemblies. <Ref. to CO-32, INSTALLATION, Radiator Main Fan and Fan Motor.> and <Ref. to CO-34, INSTALLATION, Radiator Sub Fan and Fan Motor.>

12) Install reservoir tank.

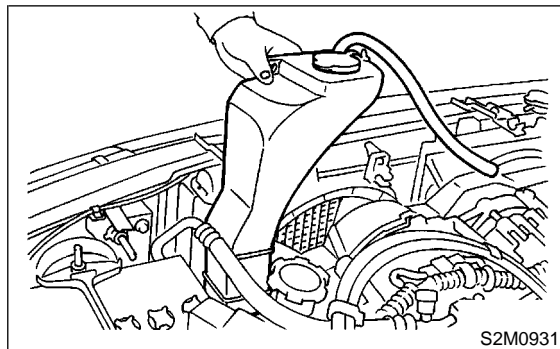

13) Connect over flow hose.

14) Lift-up the vehicle.

15) Connect radiator outlet hose (A) and heater hose (B) to water pump.

16) Connect water by-pass hose (C) and oil cooler hose (D).

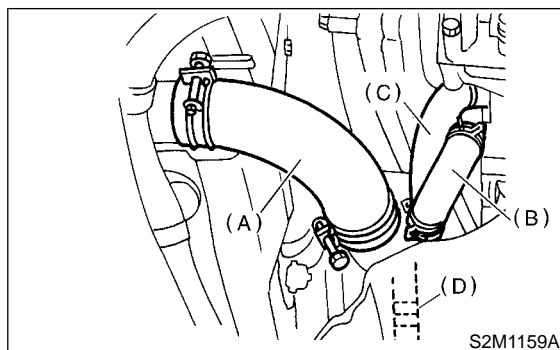

WATER PUMP

Cooling

- 17) Install bolt which installs water by-pass pipe onto oil pump.

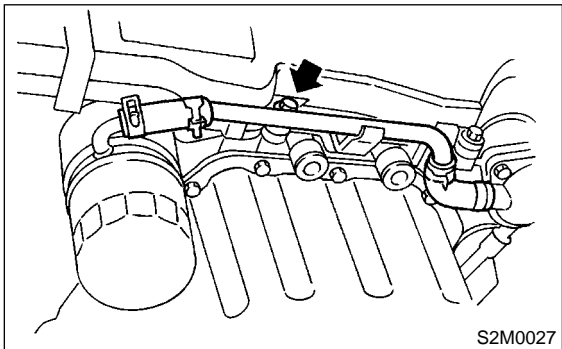

- 18) Connect connectors to radiator main fan and sub fan motors.
- 19) Install under cover.
- 20) Lower the vehicle.
- 21) Connect battery ground cable.

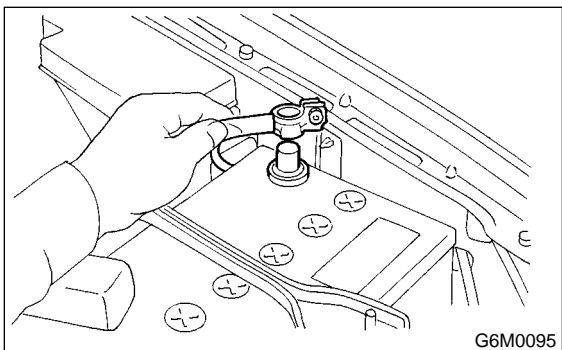

- 22) Fill coolant. <Ref. to CO-14, FILLING OF ENGINE COOLANT, REPLACEMENT, Engine Coolant.>

C: INSPECTION S176061A10

- 1) Check water pump bearing for smooth rotation.
- 2) Check water pump pulley for abnormalities.
- 3) Using a dial gauge, measure impeller runout in thrust direction while rotating the pulley.

“Thrust” runout limit:
0.5 mm (0.020 in)

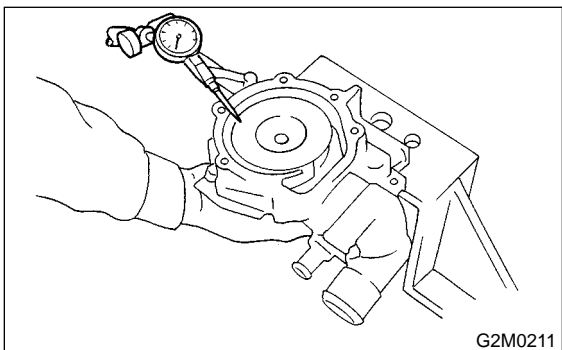

- 4) Check clearance between impeller and pump case.

Clearance between impeller and pump case:

Standard

0.5 — 0.7 mm (0.020 — 0.028 in)

Limit

1.0 mm (0.039 in)

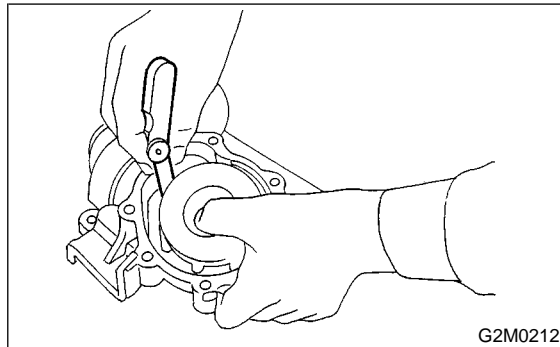

- 5) After water pump installation, check pulley shaft for engine coolant leaks. If leaks are noted, replace water pump assembly.

6. Thermostat S176062

A: REMOVAL S176062A18

- 1) Lift-up the vehicle.
- 2) Remove under cover.
- 3) Drain engine coolant completely. <Ref. to CO-14, DRAINING OF ENGINE COOLANT, REPLACEMENT, Engine Coolant.>

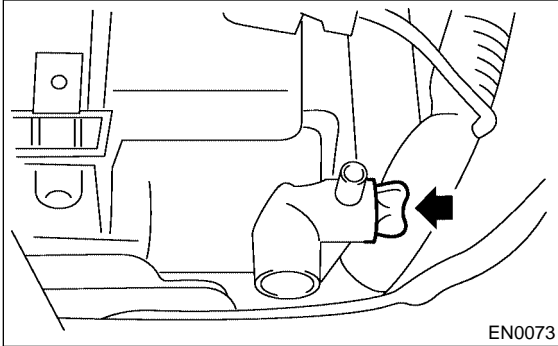

- 4) Disconnect radiator outlet hose from thermostat cover.

- Non-Turbo model

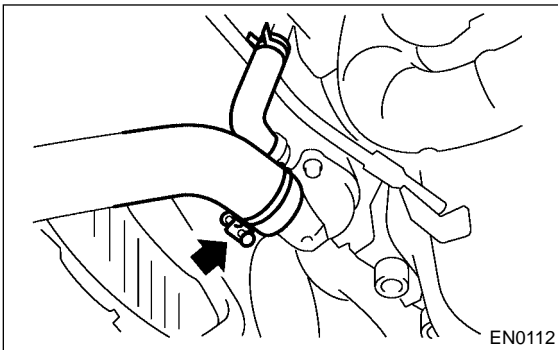

- Turbo model

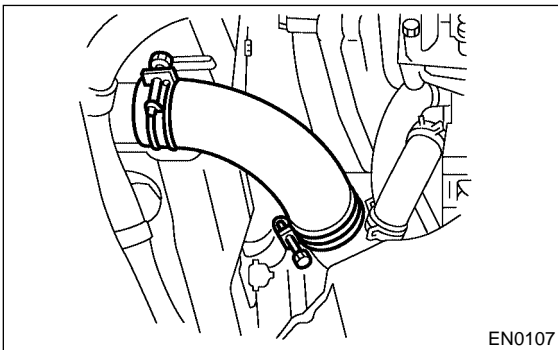

- 5) Remove thermostat cover and gasket, and pull out the thermostat.

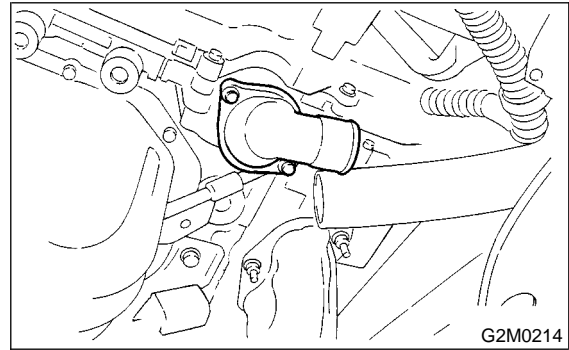

B: INSTALLATION S176062A11

- 1) Install the thermostat in the water pump, and install the thermostat cover together with a gasket.

CAUTION:

- When reinstalling the thermostat, use a new gasket.
- The thermostat must be installed with the jiggle pin (A) facing to front side.
- At this time, set the jiggle pin of thermostat for front side.

Tightening torque:

6.4 N·m (0.65 kgf·m, 4.7 ft·lb)

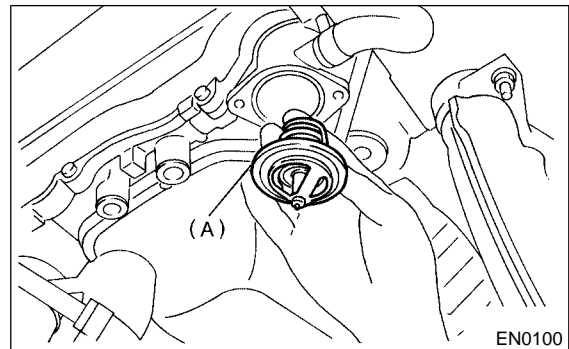

- 2) Fill coolant. <Ref. to CO-14, FILLING OF ENGINE COOLANT, REPLACEMENT, Engine Coolant.>

C: INSPECTION S176062A10

Replace the thermostat if the valve does not close completely at an ambient temperature or if the following test shows unsatisfactory results. Immerse the thermostat and a thermometer in water. Raise water temperature gradually, and measure the temperature and valve lift when the valve begins to open and when the valve is fully opened. During the test, agitate the water for even temperature distribution. The measurement should be to the specification.

THERMOSTAT

Cooling

Starts to open:

76 — 80°C (169 — 176°F)

Fully opens:

91°C (196°F)

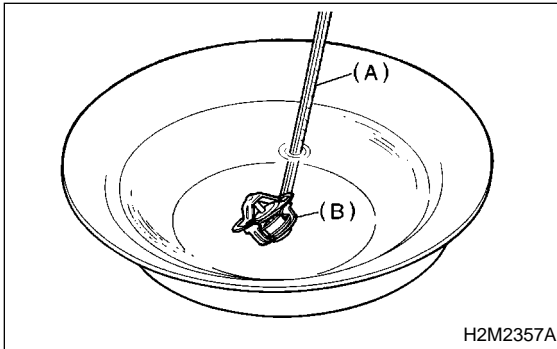

- (A) Thermometer
- (B) Thermostat

7. Radiator S176058

A: REMOVAL S176058A18

1. NON-TURBO MODEL S176058A1801

1) Disconnect battery ground cable.

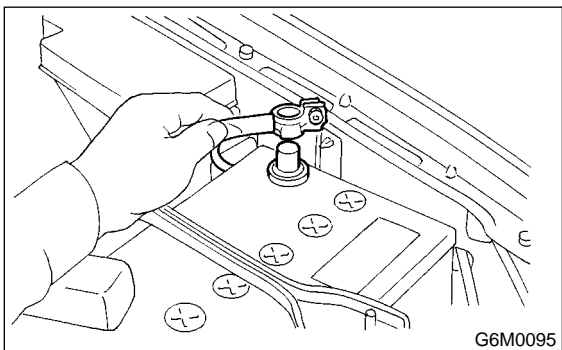

2) Lift-up the vehicle.

3) Drain engine coolant completely. <Ref. to CO-14, DRAINING OF ENGINE COOLANT, REPLACEMENT, Engine Coolant.>

4) Disconnect connectors of radiator main fan (A) and sub fan (B) motor.

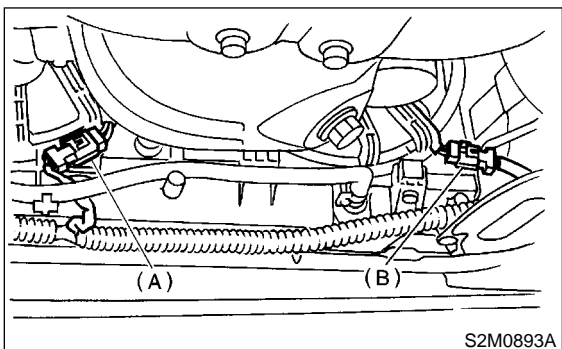

5) Disconnect radiator outlet hose (A) from thermostat cover.

6) Disconnect ATF cooler hoses (B) from radiator. (AT vehicles only)

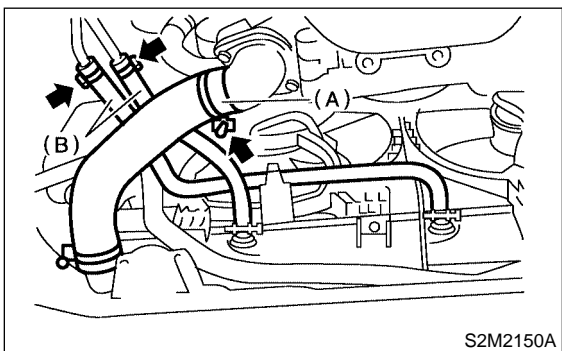

7) Lower the vehicle.

8) Remove V-belt covers.

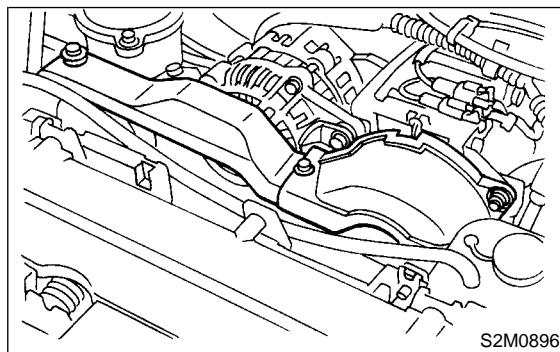

9) Disconnect over flow hose.

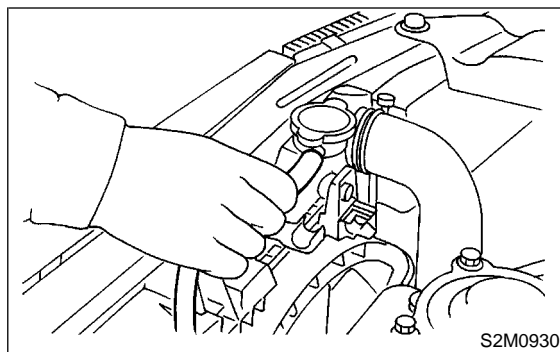

10) Remove reservoir tank.

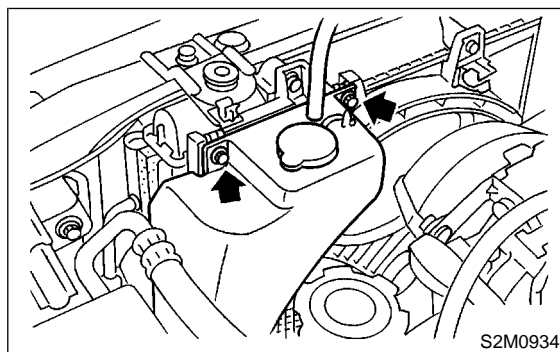

11) Disconnect radiator inlet hose from radiator.

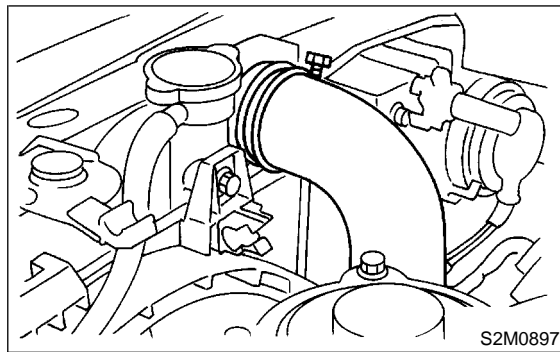

RADIATOR

Cooling

- 12) Remove radiator upper brackets.

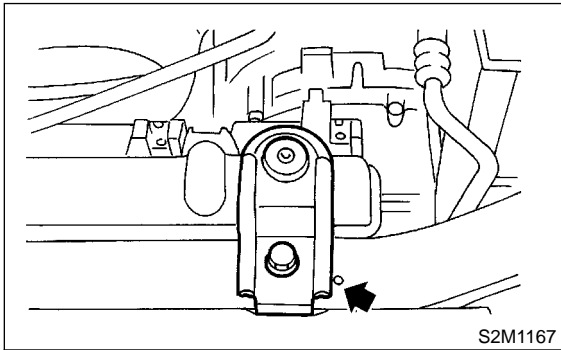

- 13) While slightly lifting radiator, slide it to left.
- 14) Lift radiator up and away from vehicle.

2. TURBO MODEL S176058A1802

WARNING:

The radiator is pressurized. Wait until engine cools down before working on the radiator.

- 1) Set the vehicle on the lift.
- 2) Disconnect battery ground cable.

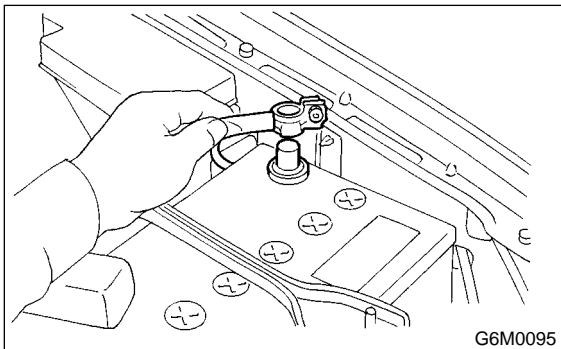

- 3) Lift-up the vehicle.
- 4) Remove under cover.
- 5) Drain engine coolant completely. <Ref. to CO-14, DRAINING OF ENGINE COOLANT, REPLACEMENT, Engine Coolant.>

- 6) Disconnect connectors of radiator main fan (A) and sub fan motor (B).

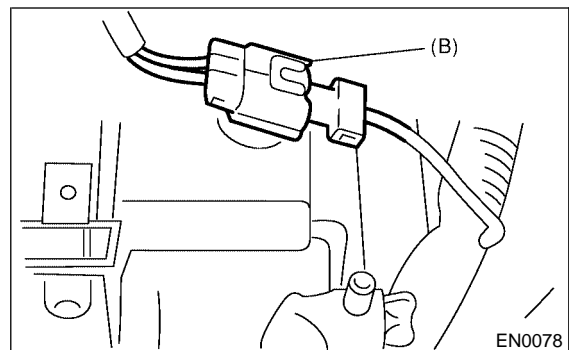
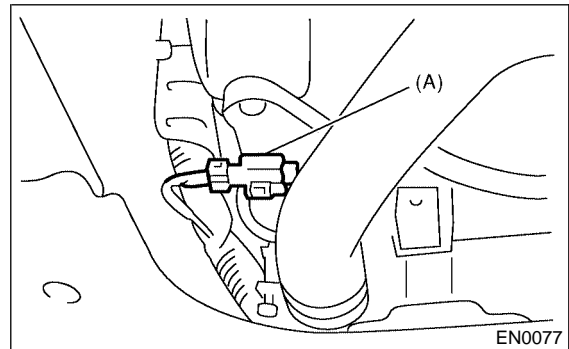

- 7) Disconnect oil cooler hoses from oil cooler pipes. (if equipped)

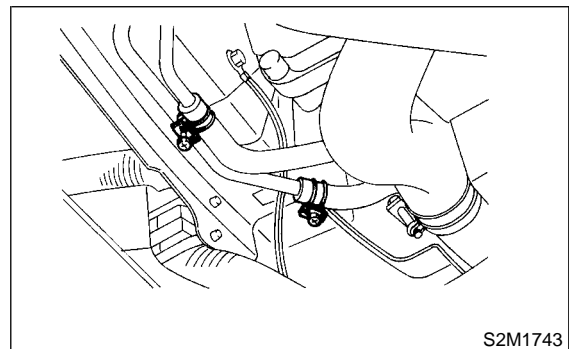

- 8) Disconnect radiator outlet hose from thermostat cover.

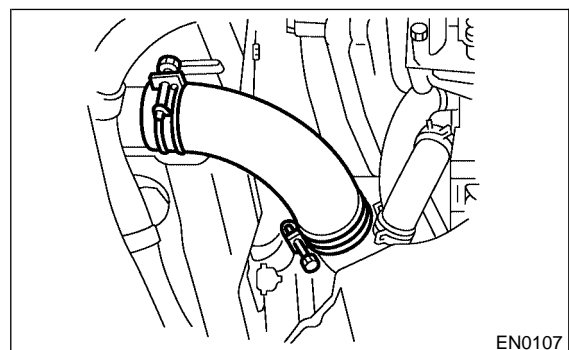

- 9) Lower the vehicle.
- 10) Disconnect over flow hose.

11) Remove reservoir tank.

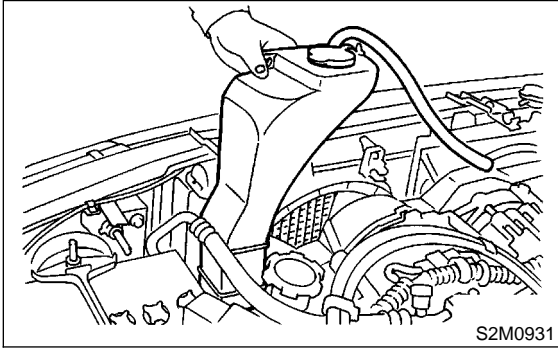

12) Remove V-belt covers.

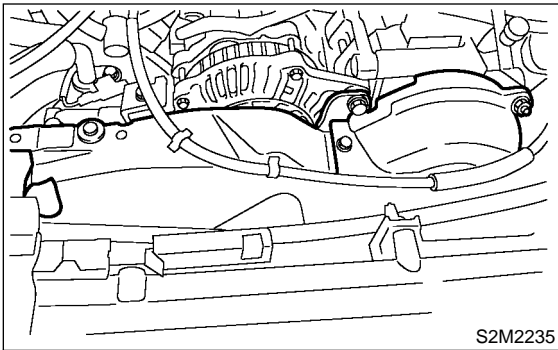

13) Disconnect radiator inlet hose (A) and water tank hose (B) from radiator.

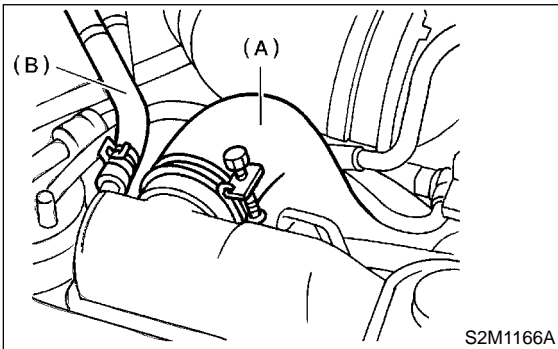

14) Remove radiator upper brackets.

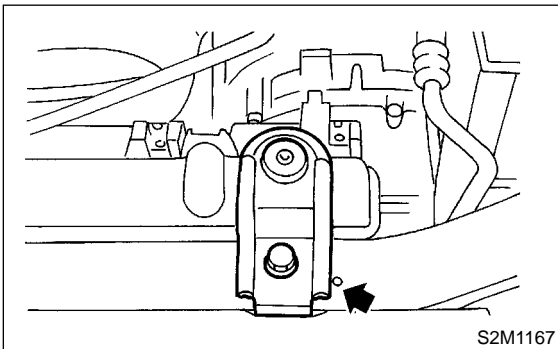

15) While slightly lifting radiator, slide it to left.
 16) Lift radiator up and away from vehicle.

B: INSTALLATION S176058A11

1. NON-TURBO MODEL S176058A1101

1) Attach radiator mounting cushions to pins on the lower side of radiator.

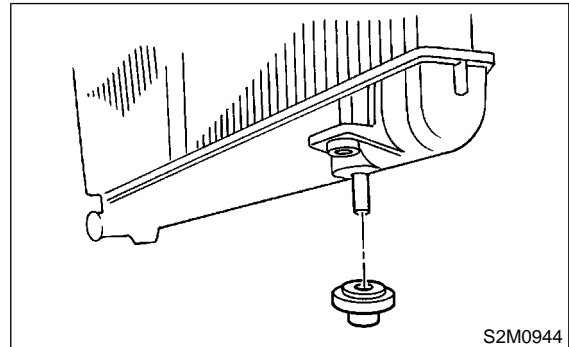

2) Install radiator while fitting radiator pins to cushions.

NOTE:

Fit pins on lower side of radiator into cushions on body side.

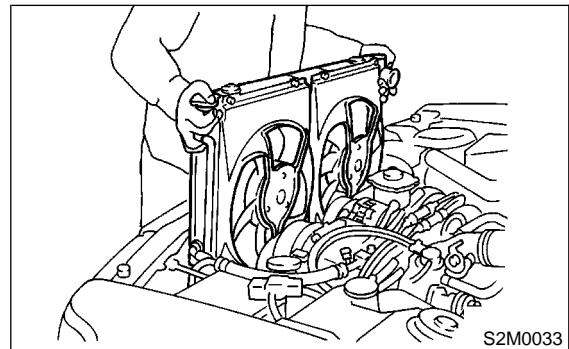

3) Install radiator brackets and tighten bolts.

Tightening torque:

18 N·m (1.8 kgf-m, 13.0 ft-lb)

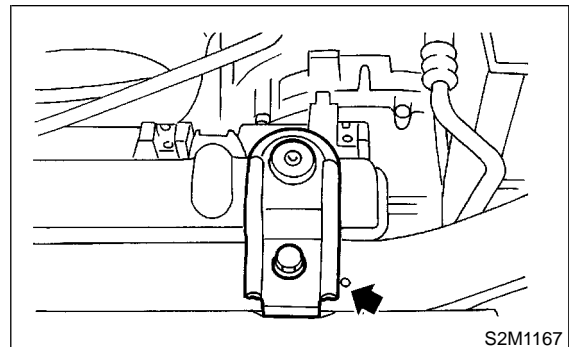

RADIATOR

Cooling

- 4) Connect radiator inlet hose.

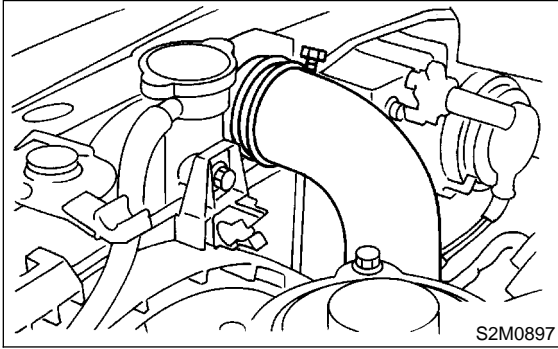

- 5) Install reservoir tank.

Tightening torque:

4.9 N·m (0.50 kgf·m, 3.6 ft·lb)

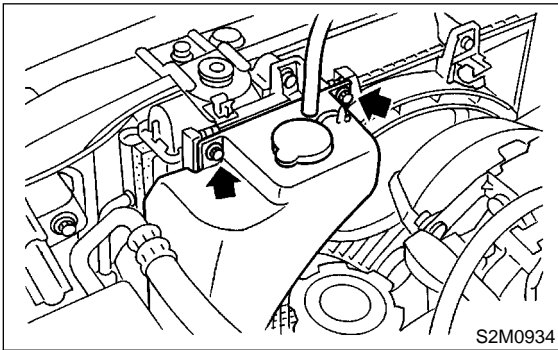

- 6) Lift-up the vehicle.
7) Connect radiator outlet hose (A).
8) Connect ATF cooler hoses (B). (AT vehicles only)

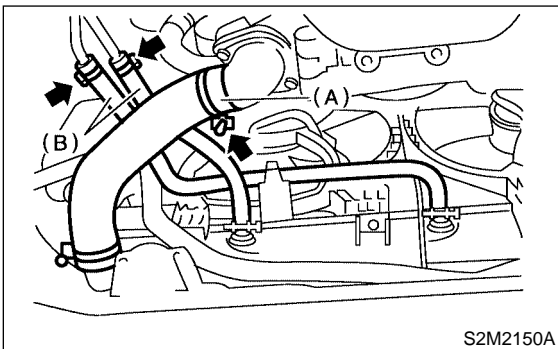

- 9) Connect connectors to radiator main fan motor (A) and sub fan motor (B).

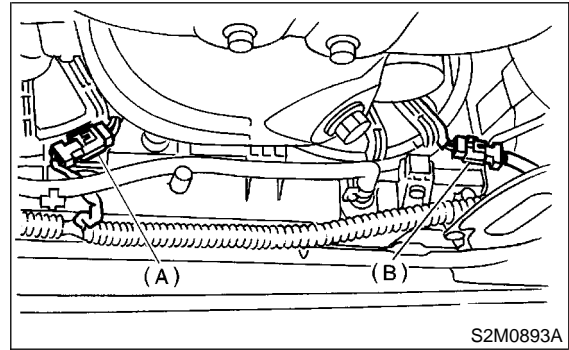

- 10) Install under cover.
11) Lower the vehicle.
12) Install V-belt covers.

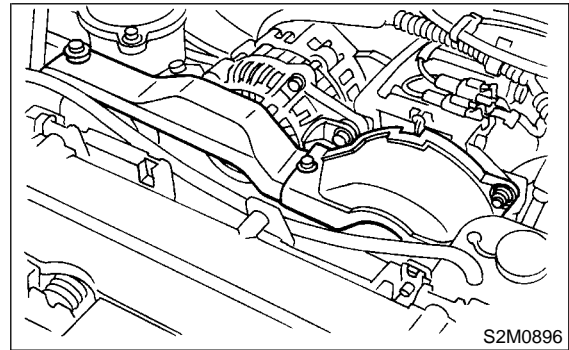

- 13) Connect battery ground cable.

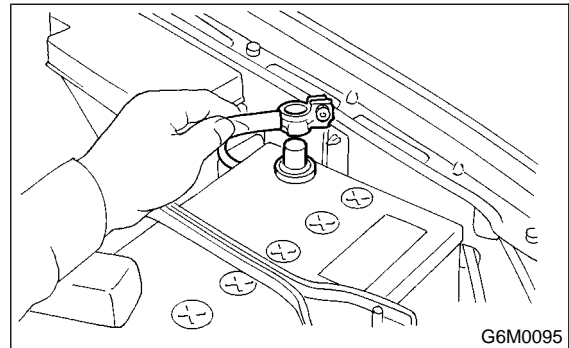

- 14) Fill coolant. <Ref. to CO-14, FILLING OF ENGINE COOLANT, REPLACEMENT, Engine Coolant.>

- 15) Check ATF level. <Ref. to AT-9, INSPECTION, Automatic Transmission Fluid.>

2. TURBO MODEL S176058A1102

1) Attach radiator mounting cushions (A) to pins on the lower side of radiator under cover (B).

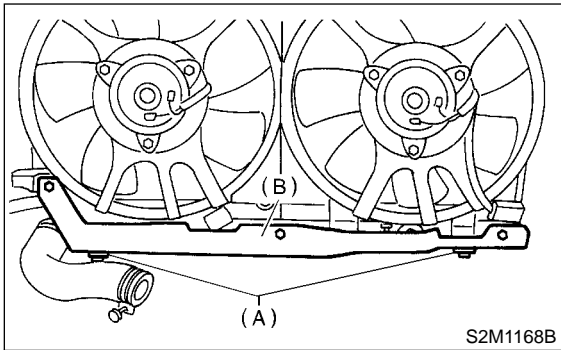

S2M1168B

2) Install radiator brackets and tighten bolts.

Tightening torque:
18 N·m (1.8 kgf-m, 13.0 ft-lb)

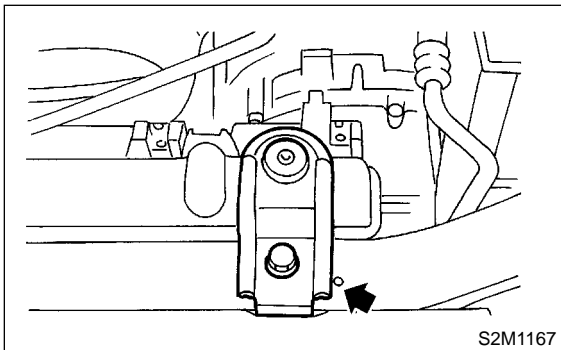

S2M1167

3) Connect radiator inlet hose (A) and water tank hose (B).

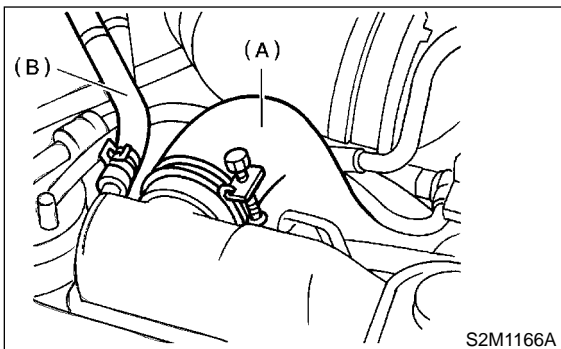

S2M1166A

4) Install reservoir tank.

Tightening torque:
4.9 N·m (0.50 kgf-m, 3.6 ft-lb)

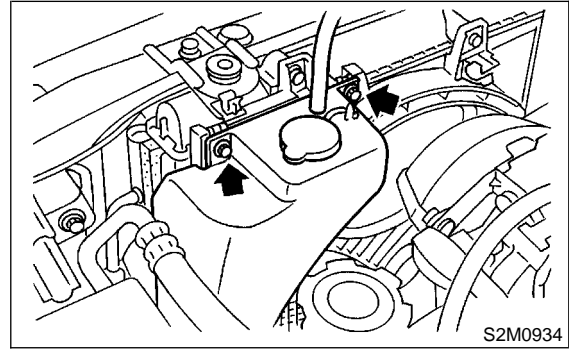

S2M0934

5) Connect over flow hose.

6) Lift-up the vehicle.

7) Connect connectors to radiator main fan motor (A) and sub fan motor (B).

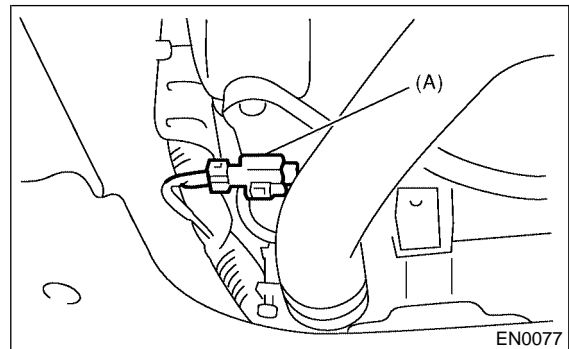

EN0077

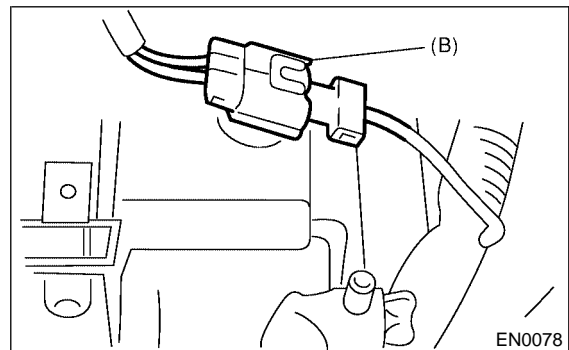

EN0078

8) Connect oil cooler hoses. (if equipped)

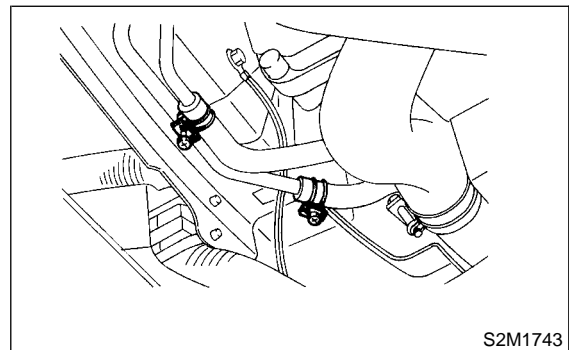

S2M1743

RADIATOR

Cooling

9) Connect radiator outlet hose.

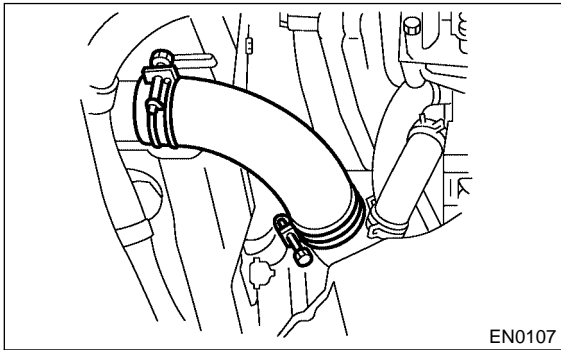

- 10) Install under cover.
- 11) Lower the vehicle.
- 12) Install V-belt covers.

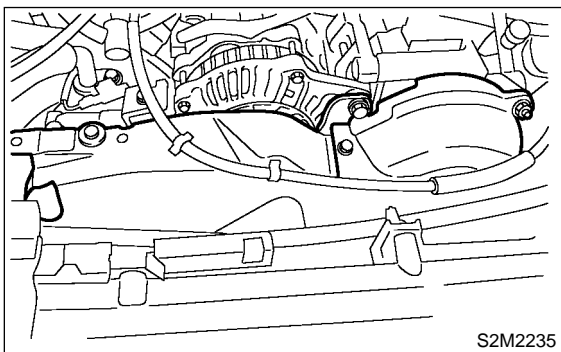

13) Connect battery ground cable.

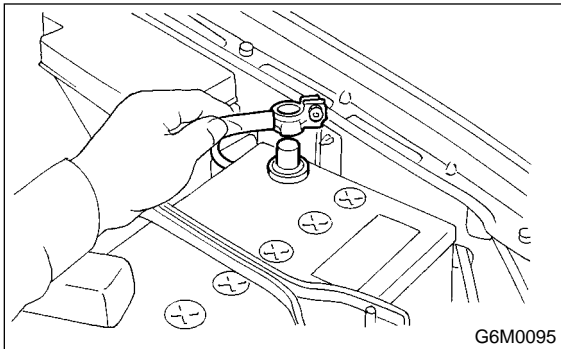

14) Fill coolant. <Ref. to CO-14, FILLING OF ENGINE COOLANT, REPLACEMENT, Engine Coolant.>

C: INSPECTION S176058A10

- 1) Remove radiator cap, top off radiator, and attach tester to radiator in place of cap.
 - Non-Turbo model

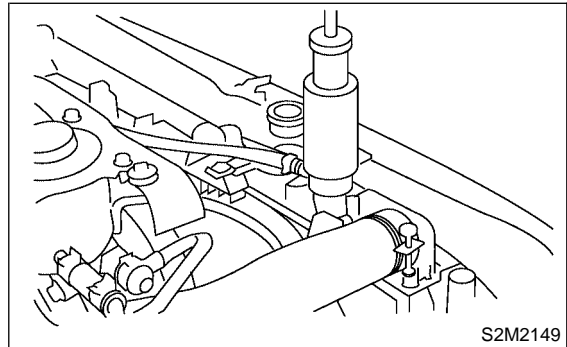

- Turbo model

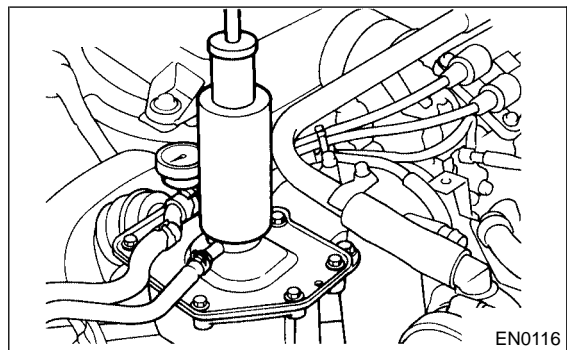

- 2) Apply a pressure of 157 kPa (1.6 kg/cm², 23 psi) to radiator to check if:
 - (1) Engine coolant leaks at/around radiator.
 - (2) Engine coolant leaks at/around hoses or connections.

CAUTION:

- Engine should be off.
- Wipe engine coolant from check points in advance.
- Be careful to prevent engine coolant from spurting out when removing tester.
- Be careful also not to deform filler neck of radiator when installing or removing tester.

8. Radiator Cap S176064

A: INSPECTION S176064A10

- 1) Attach radiator cap to tester.

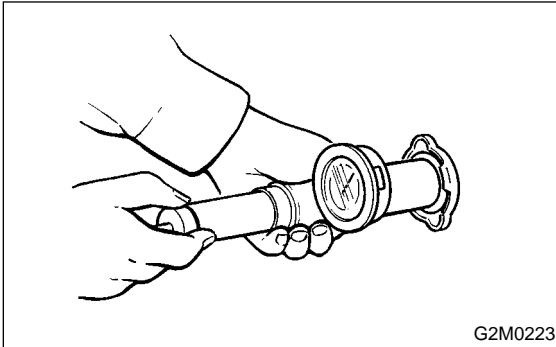

- 2) Increase pressure until tester gauge pointer stops. Radiator cap is functioning properly if it holds the service limit pressure for five to six seconds.

Standard pressure:

93 — 123 kPa (0.95 — 1.25 kg/cm², 14 — 18 psi)

Service limit pressure:

83 kPa (0.85 kg/cm², 12 psi)

CAUTION:

Be sure to remove foreign matter and rust from the cap in advance otherwise, results of pressure test will be incorrect.

RADIATOR MAIN FAN AND FAN MOTOR

Cooling

9. Radiator Main Fan and Fan Motor

S176059

A: REMOVAL

S176059A18

- 1) Disconnect battery ground cable.

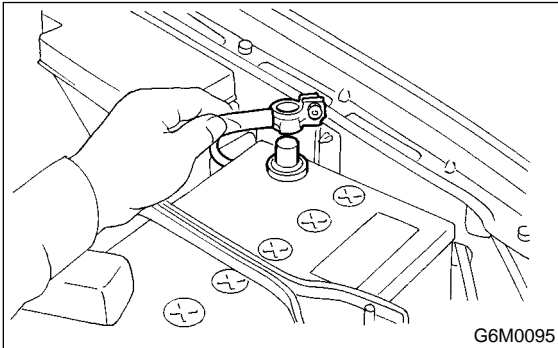

G6M0095

- 2) Lift-up the vehicle.
- 3) Remove under cover.
- 4) Disconnect connector of main fan motor.
- 5) Remove bolts which install radiator onto radiator cover. (Turbo model)

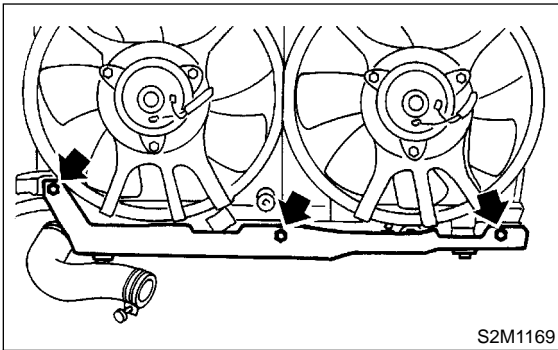

S2M1169

- 6) Lower the vehicle.
- 7) Remove V-belt cover.

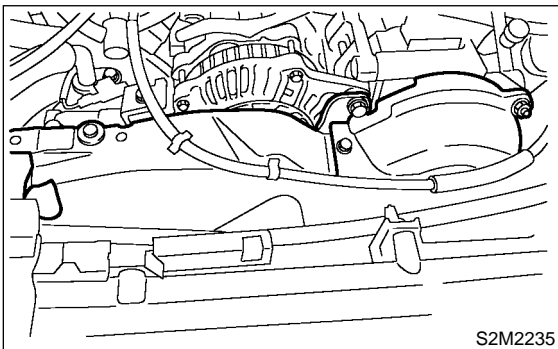

S2M2235

- 8) Disconnect over flow hose.

- 9) Remove reservoir tank.

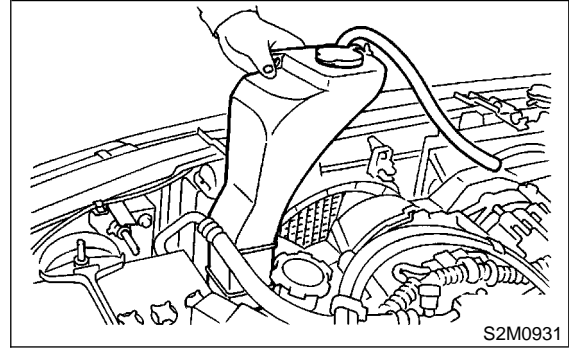

S2M0931

- 10) Lift-up radiator main fan motor assembly.
- 11) While lifting up radiator main fan motor assembly, detach oil cooler hose attached to a clip under the radiator main fan shroud. (Oil cooler equipped vehicles only)

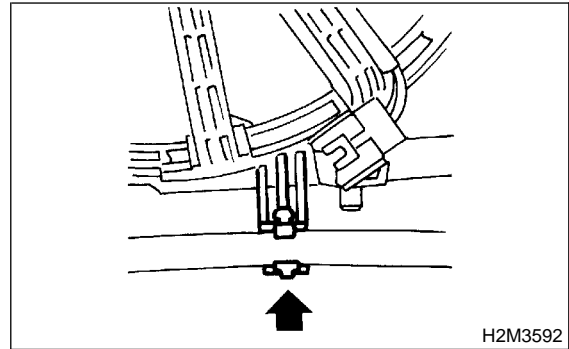

H2M3592

- 12) Remove radiator main fan motor assembly.

B: INSTALLATION

S176059A11

Install in the reverse order of removal.

NOTE:

When the main fan motor assembly cannot be installed as is, loosen the sub fan motor assembly securing bolts to install it.

Tightening torque:

4.9 N·m (0.50 kgf·m, 3.6 ft·lb)

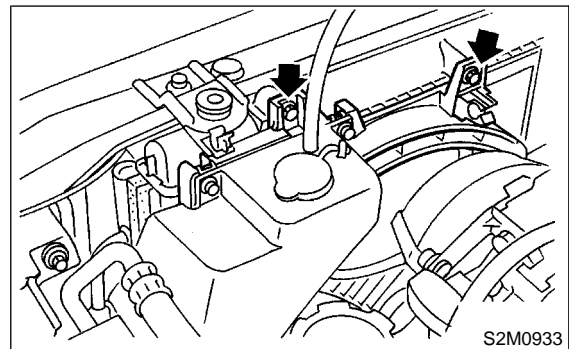

S2M0933

Tightening torque:
4.9 N·m (0.50 kgf·m, 3.6 ft·lb)

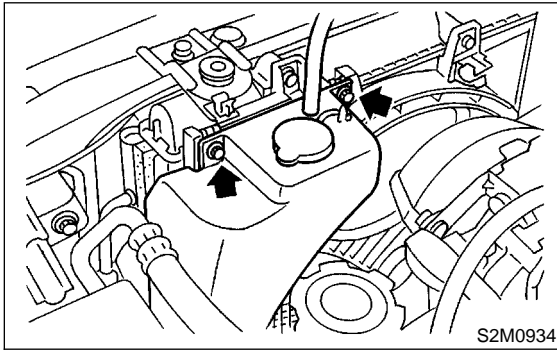

3) Remove bolts which install fan motor onto shroud.

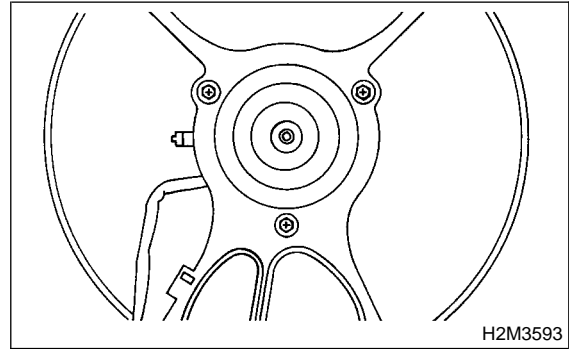

C: DISASSEMBLY S176059A06

1) Remove clip which holds motor connector onto shroud.

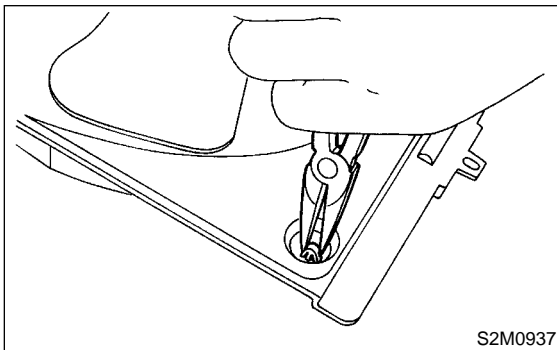

2) Remove nut which holds fan itself onto fan motor and shroud assembly.

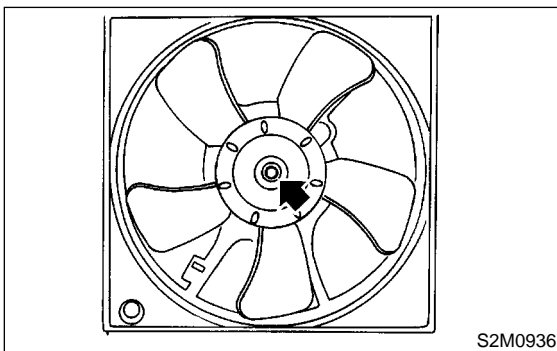

D: ASSEMBLY S176059A02

Assemble in the reverse order of disassembly.

Tightening torque:
4.4 N·m (0.45 kgf·m, 3.3 ft·lb)

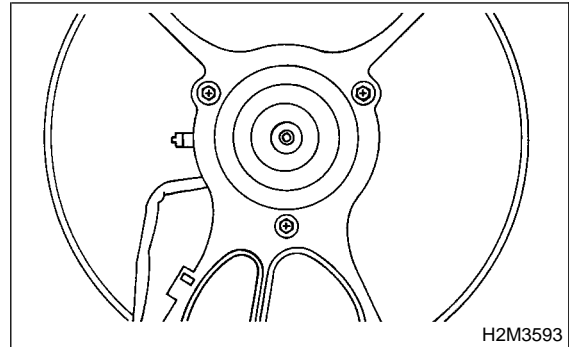

Tightening torque:
3.4 N·m (0.35 kgf·m, 2.5 ft·lb)

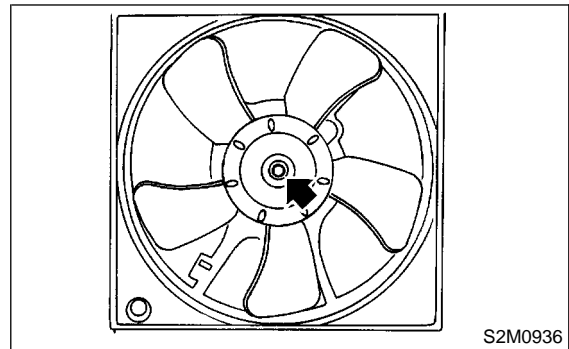

RADIATOR SUB FAN AND FAN MOTOR

Cooling

10. Radiator Sub Fan and Fan Motor

S176074

A: REMOVAL

S176074A18

- 1) Disconnect battery ground cable.

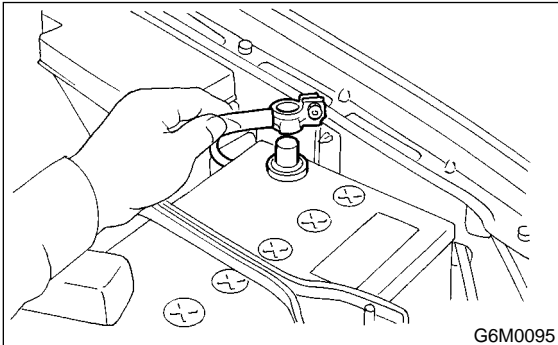

- 2) Lift-up the vehicle.
- 3) Remove under cover.
- 4) Disconnect connector of sub fan motor.
- 5) Lower the vehicle.
- 6) Remove bolts which hold sub fan shroud to radiator.
- 7) Remove radiator sub fan shroud through the under side of vehicle.

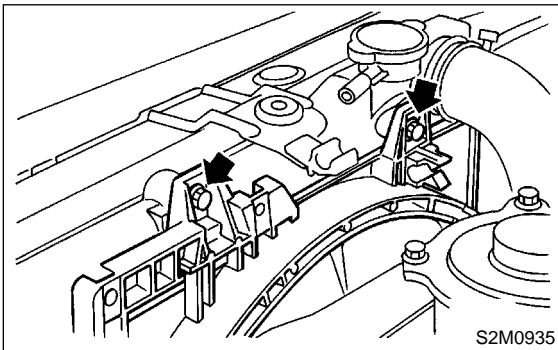

B: INSTALLATION

S176074A11

Install in the reverse order of removal.

Tightening torque:

4.9 N·m (0.50 kgf·m, 3.6 ft·lb)

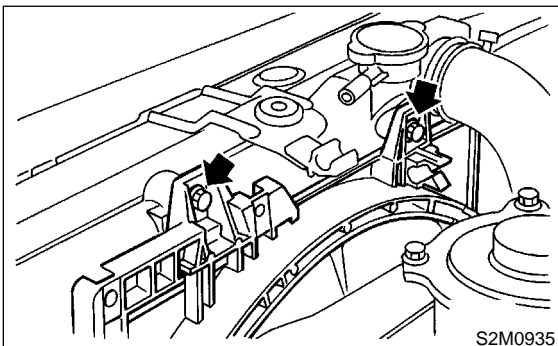

C: DISASSEMBLY

S176074A06

- 1) Remove clip which holds motor harness onto shroud.

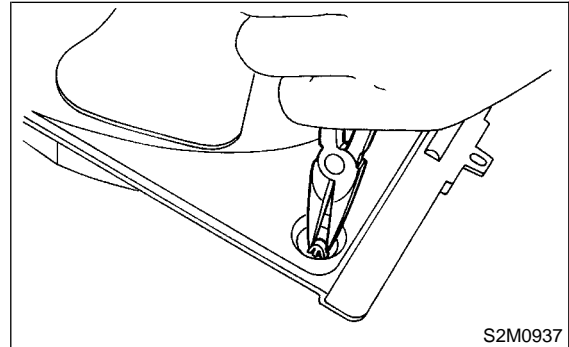

- 2) Remove nut which holds fan itself onto fan motor and shroud assembly.

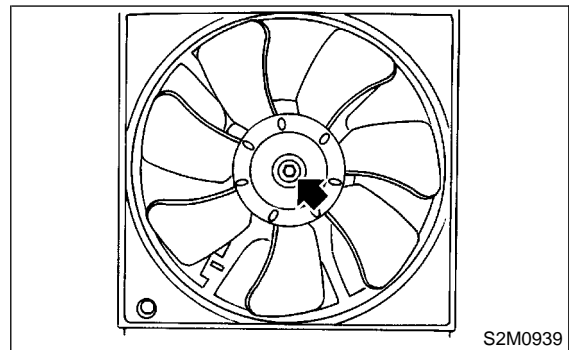

- 3) Remove bolts which install fan motor onto shroud.

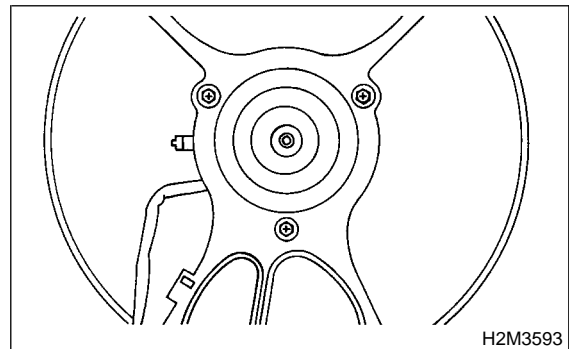

D: ASSEMBLY S176074A02

Assemble in the reverse order of disassembly.

Tightening torque:
4.4 N·m (0.45 kgf·m, 3.3 ft-lb)

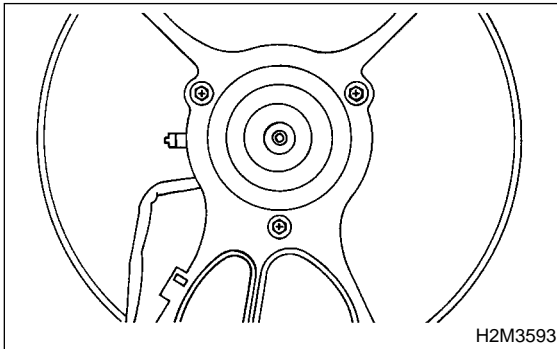

Tightening torque:
3.4 N·m (0.35 kgf·m, 2.5 ft-lb)

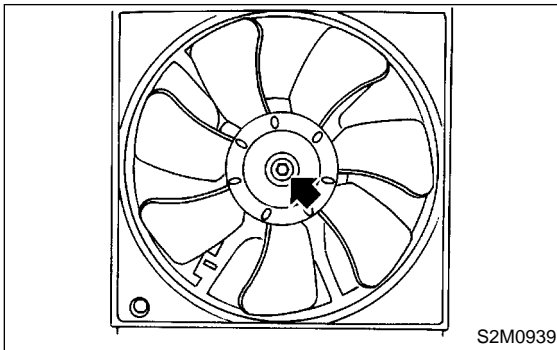

11. Reservoir Tank S176075

A: REMOVAL S176075A18

- 1) Disconnect over flow hose from radiator filler neck position.
- 2) Remove bolts which install reservoir tank onto radiator main fan shroud.
- 3) Remove reservoir tank.

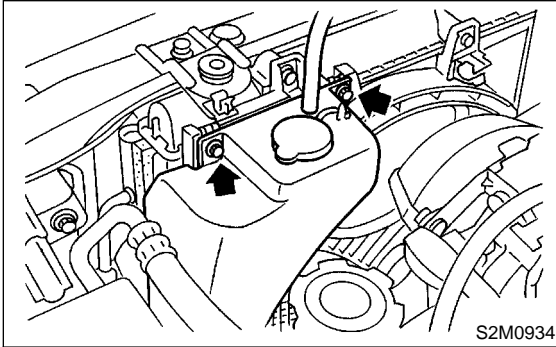

B: INSTALLATION S176075A11

Install in the reverse order of removal.

Tightening torque:

4.9 N-m (0.50 kgf-m, 3.6 ft-lb)

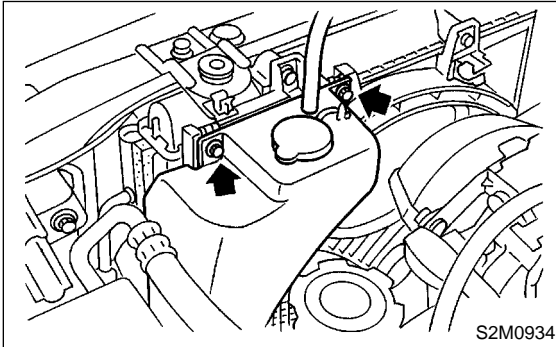

C: INSPECTION S176075A10

Make sure the engine coolant level is between full and low.

12. Coolant Filler Tank S176764

A: REMOVAL S176764A18

WARNING:

The radiator is pressurized. Wait until engine cools down before working on the radiator.

- 1) Drain coolant about 3.0 (3.2 US qt, 2.6 Imp qt). <Ref. to CO-14, DRAINING OF ENGINE COOLANT, REPLACEMENT, Engine Coolant.>
- 2) Remove air cleaner upper cover and air intake boot. <Ref. to IN(DOHC TURBO)-7, REMOVAL, Air Cleaner.>
- 3) Remove air cleaner element.
- 4) Disconnect engine coolant hoses from coolant filler tank.

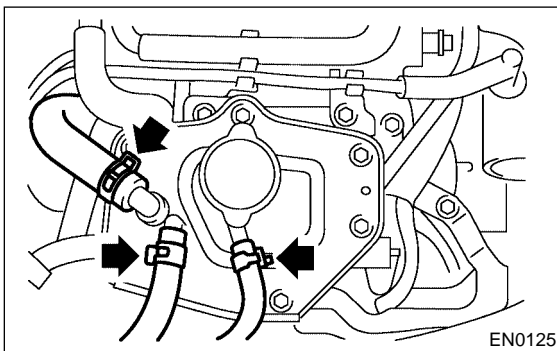

- 5) Remove bolts and nut which install coolant filler tank.
- 6) Disconnect engine coolant hose which connects the under side of coolant filler tank.
- 7) Remove coolant filler tank.

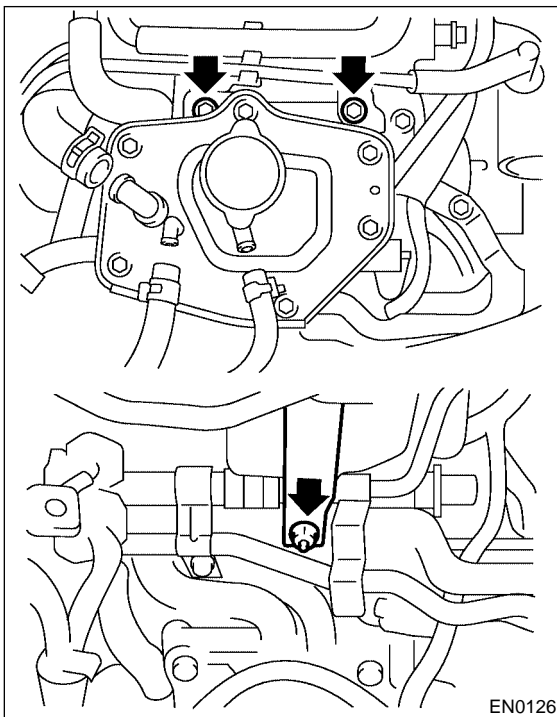

B: INSTALLATION S176764A11

- 1) Install in the reverse order of removal.

Tightening torque:

T1: 19 N·m (1.9 kgf-m, 13.7 ft-lb)

T2: 21 N·m (2.1 kgf-m, 15.2 ft-lb)

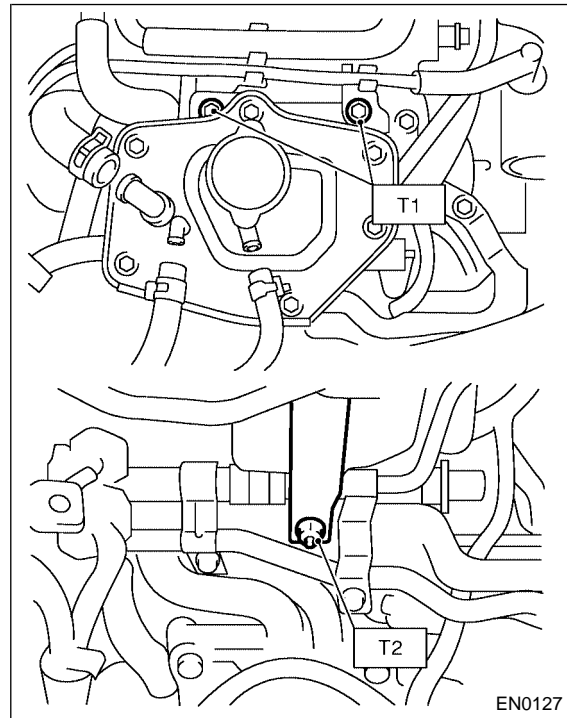

- 2) Fill engine coolant. <Ref. to CO-14, FILLING OF ENGINE COOLANT, REPLACEMENT, Engine Coolant.>

ENGINE COOLING SYSTEM TROUBLE IN GENERAL

Cooling

13. Engine Cooling System Trouble in General S176078

A: INSPECTION S176078A10

Trouble	Possible cause	Corrective action
Over-heating	a. Insufficient engine coolant	Replenish engine coolant, inspect for leakage, and repair.
	b. Loose timing belt	Repair or replace timing belt tensioner.
	c. Oil on drive belt	Replace.
	d. Malfunction of thermostat	Replace.
	e. Malfunction of water pump	Replace.
	f. Clogged engine coolant passage	Clean.
	g. Improper ignition timing	Inspect and repair ignition control system. <Ref. to EN(SOHC)-2, Basic Diagnostic Procedure.> or <Ref. to EN(SOHCw/oOBD)-2, Basic Diagnostic Procedure.> or <Ref. to EN(DOHC TURBO)-2, PROCEDURE, Basic Diagnostic Procedure.>
	h. Clogged or leaking radiator	Clean or repair, or replace.
	i. Improper engine oil in engine coolant	Replace engine coolant.
	j. Air/fuel mixture ratio too lean	Inspect and repair fuel injection system. <Ref. to EN(SOHC)-2, Basic Diagnostic Procedure.> or <Ref. to EN(SOHCw/oOBD)-2, Basic Diagnostic Procedure.> or <Ref. to EN(DOHC TURBO)-2, PROCEDURE, Basic Diagnostic Procedure.>
	k. Excessive back pressure in exhaust system	Clean or replace.
	l. Insufficient clearance between piston and cylinder	Adjust or replace.
	m. Slipping clutch	Repair or replace.
	n. Dragging brake	Adjust.
o. Improper transmission oil	Replace.	
p. Defective thermostat	Replace.	
q. Malfunction of electric fan	Inspect radiator fan relay, engine coolant temperature sensor or radiator motor and replace there.	
Over-cooling	a. Atmospheric temperature extremely low	Partly cover radiator front area.
	b. Defective thermostat	Replace.
Engine coolant leaks.	a. Loosened or damaged connecting units on hoses	Repair or replace.
	b. Leakage from water pump	Replace.
	c. Leakage from water pipe	Repair or replace.
	d. Leakage around cylinder head gasket	Retighten cylinder head bolts or replace gasket.
	e. Damaged or cracked cylinder head and crank-case	Repair or replace.
	f. Damaged or cracked thermostat case	Repair or replace.
	g. Leakage from radiator	Repair or replace.
Noise	a. Defective drive belt	Replace.
	b. Defective radiator fan	Replace.
	c. Defective water pump bearing	Replace water pump.
	d. Defective water pump mechanical seal	Replace water pump.