

**ENGINE2 SECTION**

This service manual has been prepared to provide SUBARU service personnel with the necessary information and data for the correct maintenance and repair of SUBARU vehicles.

This manual includes the procedures for maintenance, disassembling, reassembling, inspection and adjustment of components and diagnostics for guidance of experienced mechanics.

Please peruse and utilize this manual fully to ensure complete repair work for satisfying our customers by keeping their vehicle in optimum condition. When replacement of parts during repair work is needed, be sure to use SUBARU genuine parts.

All information, illustration and specifications contained in this manual are based on the latest product information available at the time of publication approval.

<b>FUEL INJECTION (FUEL SYSTEMS)</b>	<b>FU(SOHCw/oOBD)</b>
<b>EMISSION CONTROL (AUX. EMISSION CONTROL DEVICES)</b>	<b>EC(SOHCw/oOBD)</b>
<b>EXHAUST</b>	<b>EX(SOHCw/oOBD)</b>
<b>IGNITION</b>	<b>IG(SOHCw/oOBD)</b>
<b>ENGINE (DIAGNOSTICS)</b>	<b>EN(SOHCw/oOBD)</b>
<b>FUEL INJECTION (FUEL SYSTEMS)</b>	<b>FU(DOHC TURBO)</b>
<b>EMISSION CONTROL (AUX. EMISSION CONTROL DEVICES)</b>	<b>EC(DOHC TURBO)</b>
<b>INTAKE (INDUCTION)</b>	<b>IN(DOHC TURBO)</b>
<b>MECHANICAL</b>	<b>ME(DOHC TURBO)</b>
<b>EXHAUST</b>	<b>EX(DOHC TURBO)</b>
<b>IGNITION</b>	<b>IG(DOHC TURBO)</b>
<b>ENGINE (DIAGNOSTICS)</b>	<b>EN(DOHC TURBO)</b>

# FUEL INJECTION (FUEL SYSTEMS)

# *FU(DOHC TURBO)*

---

	Page
1. General Description.....	2
2. Throttle Body.....	14
3. Intake Manifold.....	15
4. Engine Coolant Temperature Sensor.....	29
5. Crankshaft Position Sensor.....	30
6. Camshaft Position Sensor.....	31
7. Knock Sensor.....	32
8. Throttle Position Sensor.....	33
9. Mass Air Flow and Intake Air Temperature Sensor.....	34
10. Pressure Sensor.....	35
11. Idle Air Control Solenoid Valve.....	36
12. Fuel Injector.....	37
13. Tumble Generator Valve Assembly.....	40
14. Wastegate Control Solenoid Valve.....	41
15. Front Oxygen (A/F) Sensor.....	42
16. Rear Oxygen Sensor.....	44
17. Exhaust Temperature Sensor.....	46
18. Engine Control Module.....	47
19. Main Relay.....	48
20. Fuel Pump Relay.....	49
21. Fuel.....	50
22. Fuel Tank.....	53
23. Fuel Filler Pipe.....	56
24. Fuel Pump.....	60
25. Fuel Level Sensor.....	62
26. Fuel Sub Level Sensor.....	63
27. Fuel Filter.....	64
28. Fuel Cut Valve.....	65
29. Fuel Damper Valve.....	66
30. Fuel Delivery, Return and Evaporation Lines.....	67
31. Fuel System Trouble in General.....	70

# GENERAL DESCRIPTION

Fuel Injection (Fuel Systems)

## 1. General Description S185001

### A: SPECIFICATIONS S185001E49

Model		
Fuel tank	Capacity	60 ℓ (15.9 US gal, 13.2 Imp gal)
	Location	Under rear seat
Fuel pump	Type	Impeller
	Shutoff discharge pressure	450 — 677 kPa (4.59 — 6.9 kg/cm <sup>2</sup> , 65.27 — 98.2 psi)
	Discharge flow	More than 130 ℓ (34.3 US gal, 28.6 Imp gal)/h [12 V at 300 kPa (3.06 kg/cm <sup>2</sup> , 43.5 psi)]
Fuel filter		Cartridge type

# GENERAL DESCRIPTION

Fuel Injection (Fuel Systems)

---

**MEMO:**

**FU(DOHC TURBO)-3**

# GENERAL DESCRIPTION

Fuel Injection (Fuel Systems)

## B: COMPONENT

S185001A05

### 1. INTAKE MANIFOLD

S185001A0501

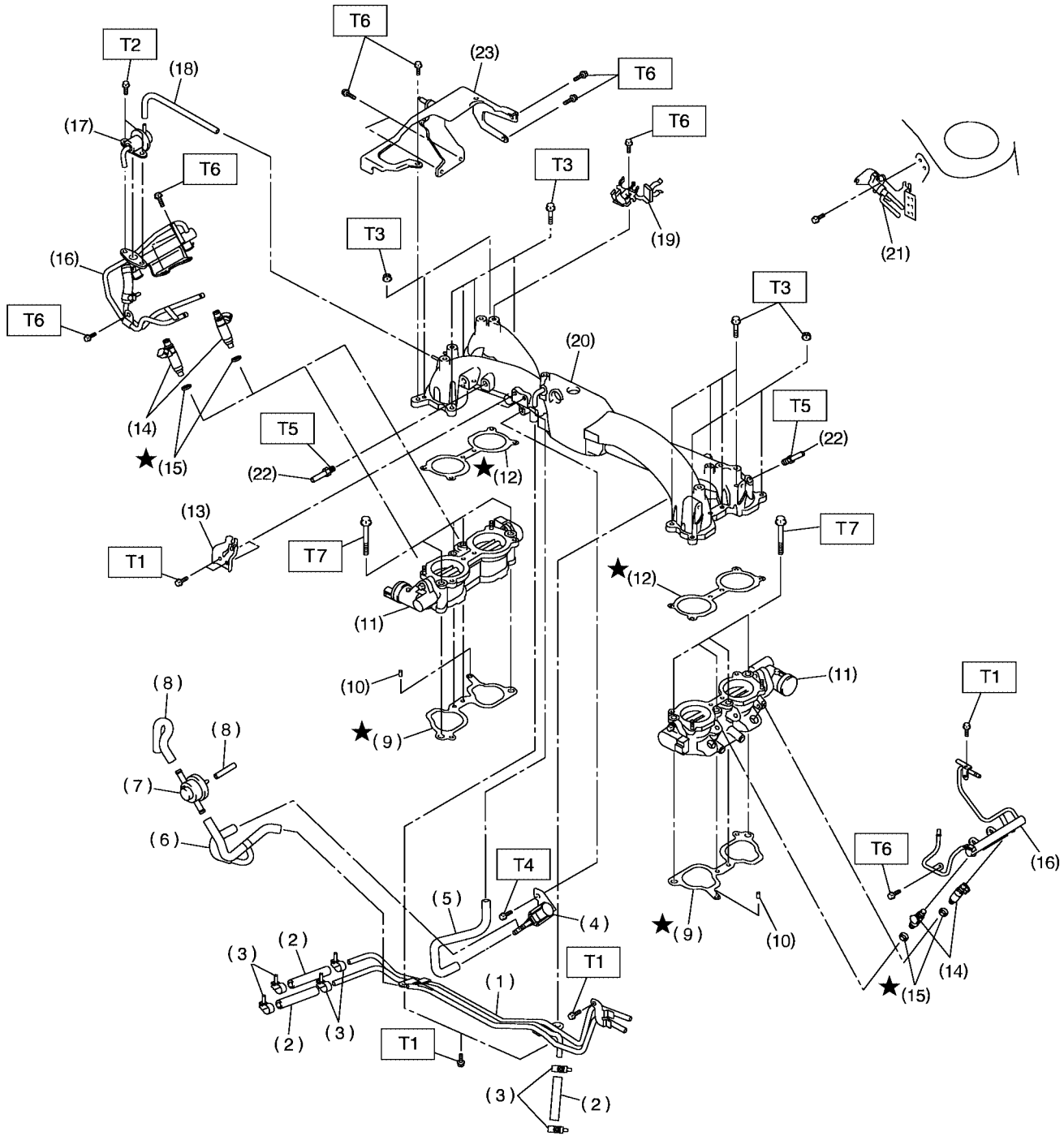

S2M2173A

FU(DOHC TURBO)-4

# GENERAL DESCRIPTION

Fuel Injection (Fuel Systems)

- (1) Fuel pipe ASSY
- (2) Fuel hose
- (3) Clip
- (4) Purge control solenoid valve
- (5) Vacuum hose
- (6) Vacuum control hose
- (7) Purge valve
- (8) Purge hose
- (9) Intake manifold gasket
- (10) Guide pin
- (11) Tumble generator valve ASSY
- (12) Tumble generator valve gasket

- (13) Accelerator cable bracket
- (14) Fuel injector
- (15) Insulator
- (16) Fuel injector pipe
- (17) Pressure regulator
- (18) Pressure regulator hose
- (19) Blow-by hose stay
- (20) Intake manifold
- (21) Wastegate control solenoid valve  
ASSY
- (22) Nipple
- (23) Fuel pipe protector

---

**Tightening torque: N·m (kgf-m, ft-lb)**

**T1: 5 (0.50, 3.7)**

**T2: 6.4 (0.65, 4.7)**

**T3: 8.25 (0.84, 6.1)**

**T4: 16 (1.63, 11.8)**

**T5: 17 (1.73, 12.5)**

**T6: 19 (1.94, 14.0)**

**T7: 25 (2.55, 18.4)**

---

# GENERAL DESCRIPTION

Fuel Injection (Fuel Systems)

## 2. AIR INTAKE SYSTEM S185001A0502

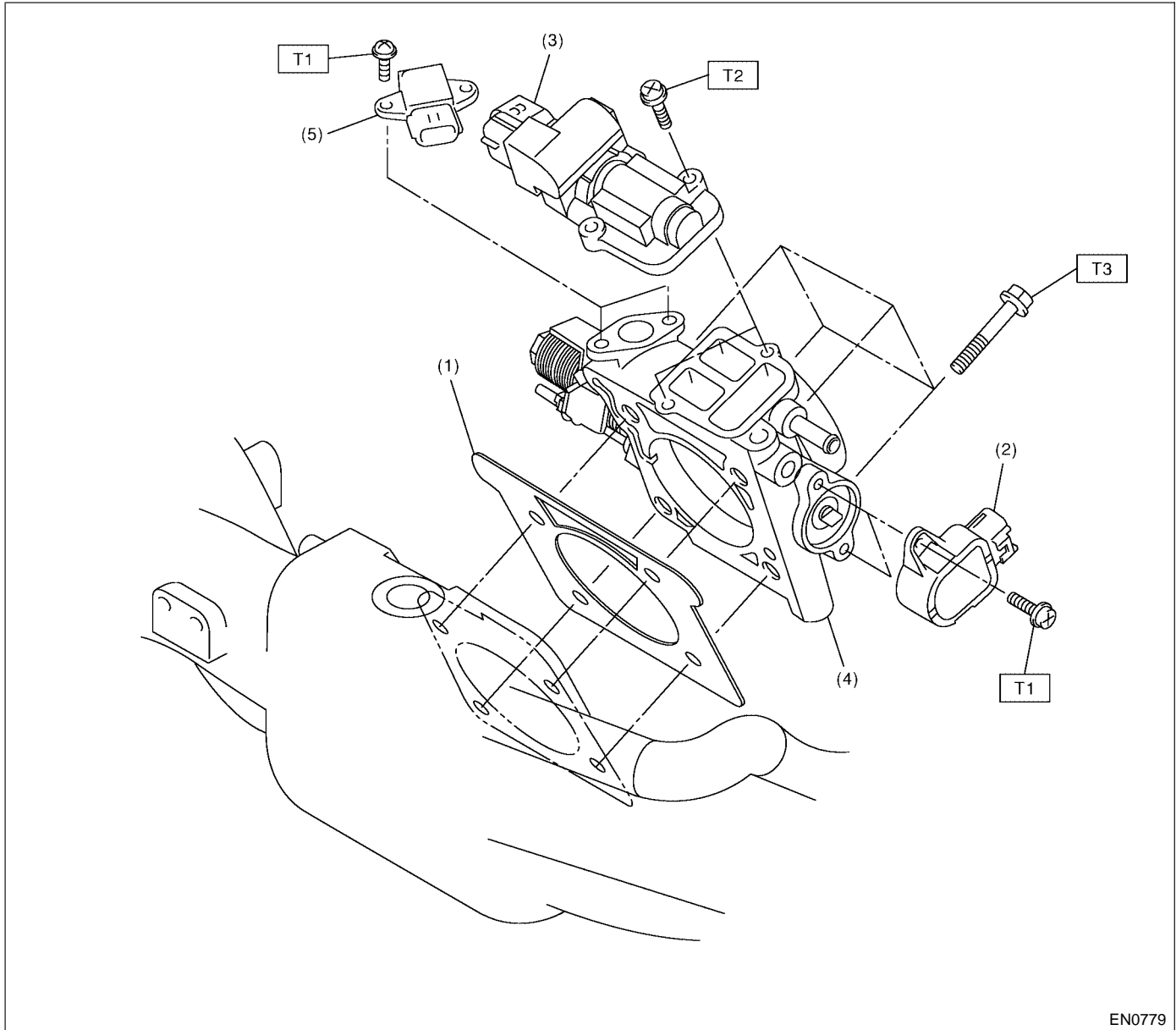

EN0779

- (1) Gasket
- (2) Throttle position sensor
- (3) Idle air control solenoid valve
- (4) Throttle body
- (5) Pressure sensor

**Tightening torque: N·m (kgf·m, ft·lb)**

**T1: 1.6 (0.16, 1.2)**

**T2: 2.8 (0.29, 2.1)**

**T3: 22 (2.2, 16)**

**FU(DOHC TURBO)-6**

## 3. CRANKSHAFT POSITION, CAMSHAFT POSITION AND KNOCK SENSORS S185001A0503

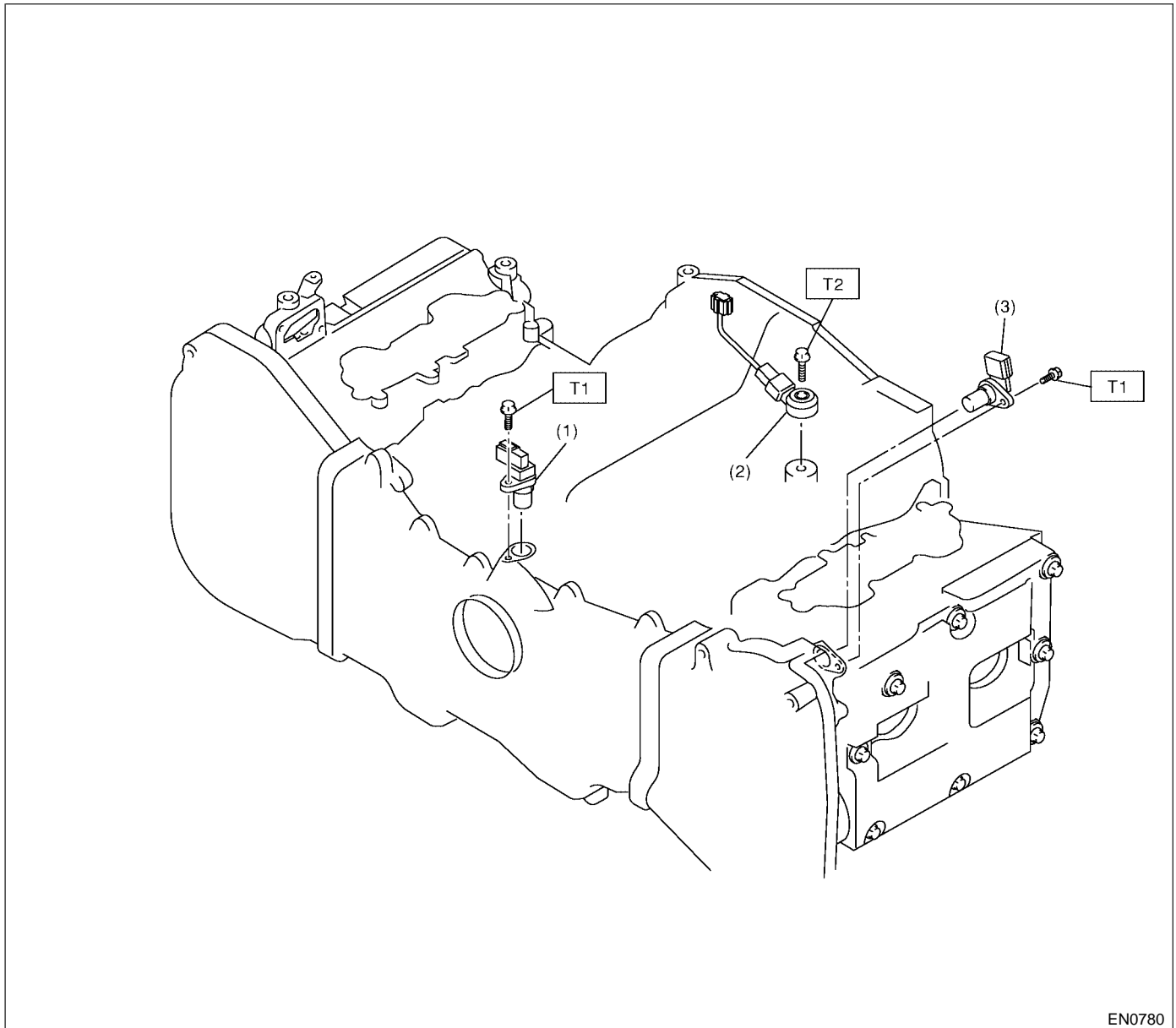

- (1) Crankshaft position sensor
- (2) Knock sensor
- (3) Camshaft position sensor

**Tightening torque: N·m (kgf-m, ft-lb)**

**T1: 6.4 (0.65, 4.7)**

**T2: 24 (2.4, 17.4)**



# GENERAL DESCRIPTION

Fuel Injection (Fuel Systems)

## 4. FUEL TANK

S185001A0504

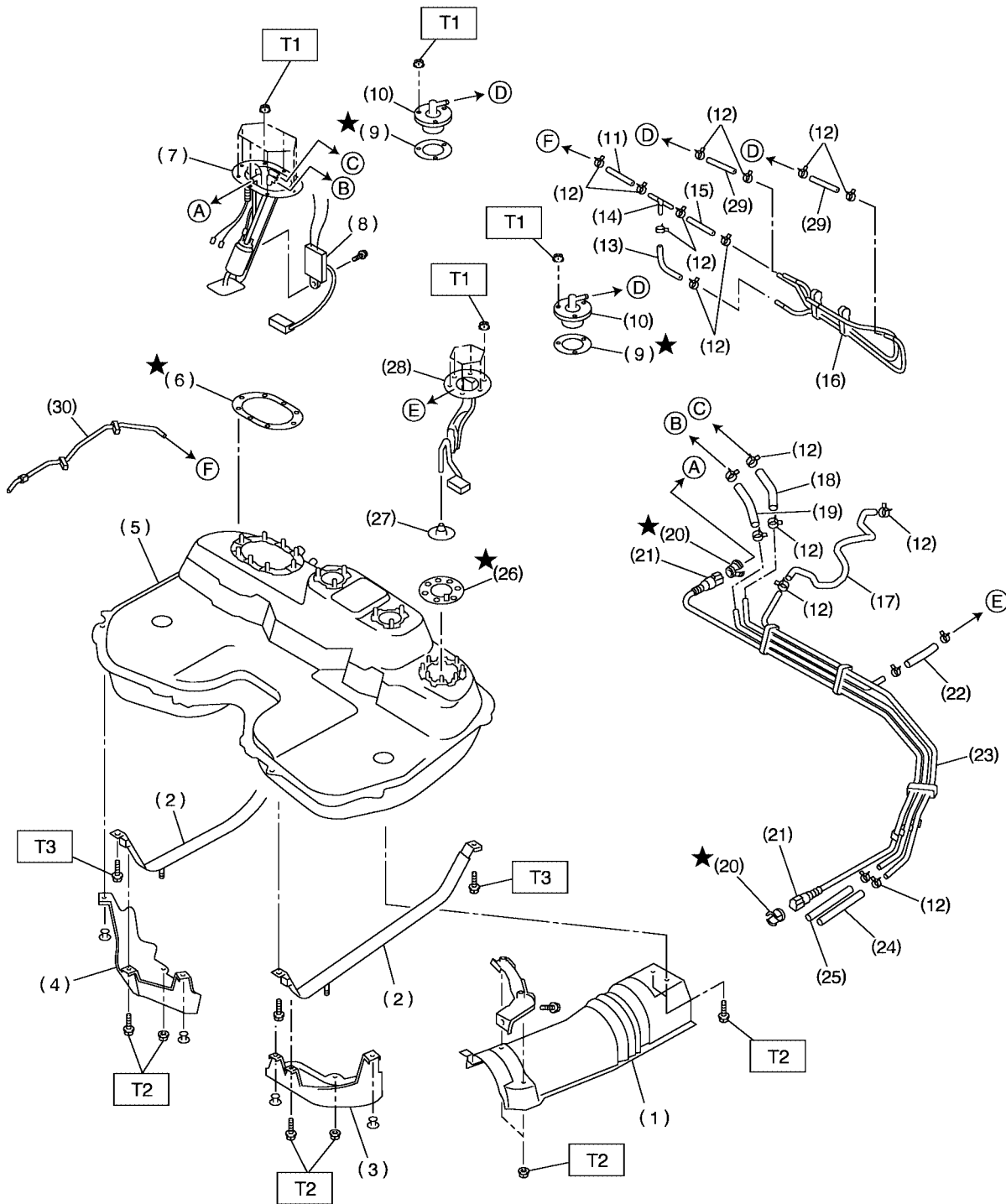

S2M2152A

FU(DOHC TURBO)-8

# GENERAL DESCRIPTION

## Fuel Injection (Fuel Systems)

---

(1) Heat sealed cover	(13) Evaporation hose B	(25) Fuel return hose B
(2) Fuel tank band	(14) Joint pipe	(26) Fuel sub level sensor gasket
(3) Protector LH	(15) Evaporation hose C	(27) Jet pump filter
(4) Protector RH	(16) Evaporation pipe ASSY	(28) Fuel sub level sensor
(5) Fuel tank	(17) Evaporation hose D	(29) Evaporation hose H
(6) Fuel pump gasket	(18) Evaporation hose E	(30) Evaporation hose I
(7) Fuel pump ASSY	(19) Fuel return hose A	
(8) Fuel level snsor	(20) Retainer	
(9) Fuel cut valve gasket	(21) Quick connector	
(10) Fuel cut valve	(22) Evaporation hose F	
(11) Evaporation hose A	(23) Fuel pipe ASSY	
(12) Clip	(24) Evaporation hose G	

---

**Tightening torque: N·m (kgf-m, ft-lb)**

**T1: 4.4 (0.45, 3.3)**

**T2: 7.4 (0.75, 5.4)**

**T3: 33 (3.4, 25)**

---

# GENERAL DESCRIPTION

Fuel Injection (Fuel Systems)

## 5. FUEL LINE S185001A0505

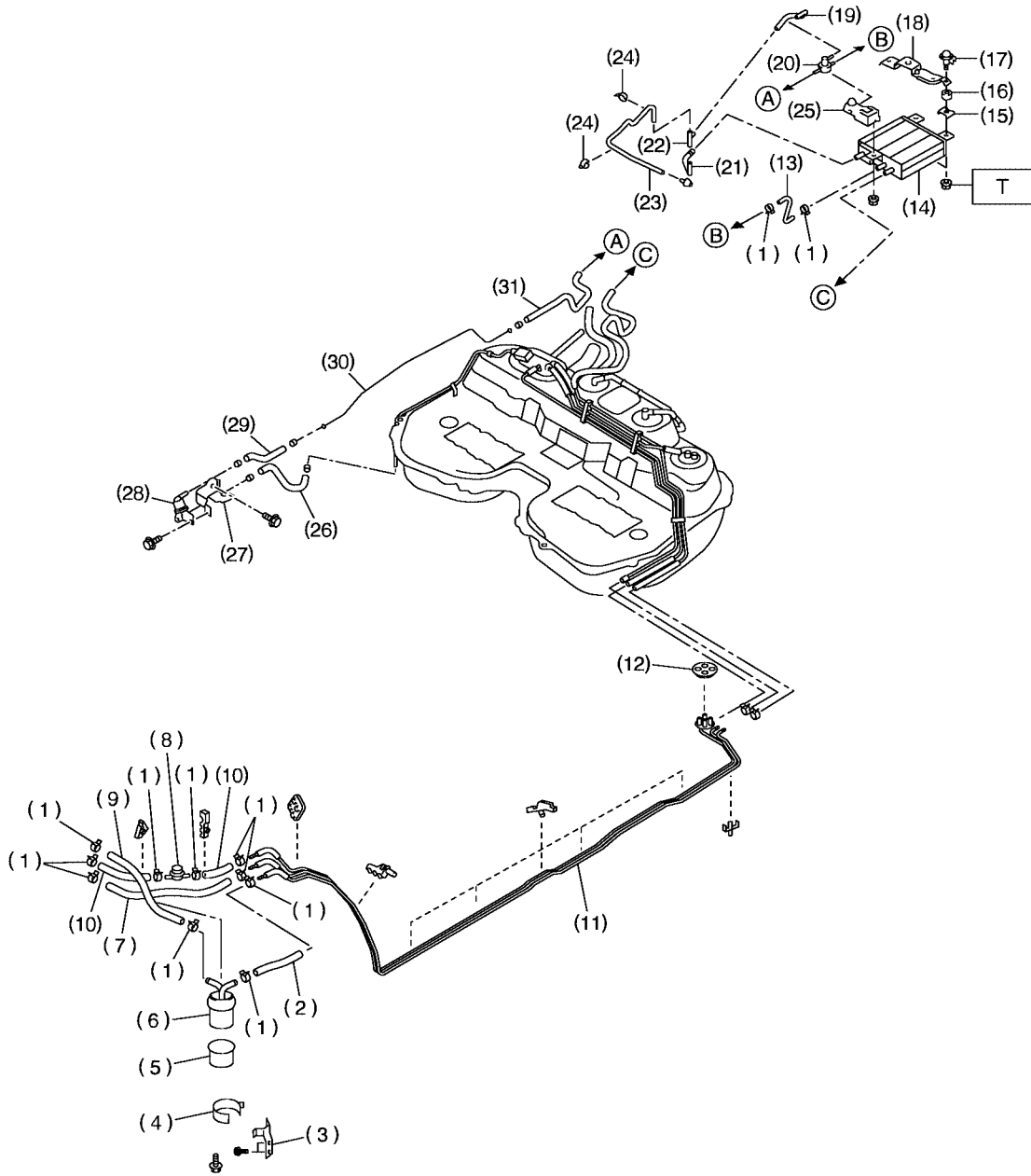

S2M2153A

FU(DOHC TURBO)-10

# GENERAL DESCRIPTION

## Fuel Injection (Fuel Systems)

- 
- |                          |                                 |                              |
|--------------------------|---------------------------------|------------------------------|
| (1) Clip                 | (13) Canister hose A            | (25) Front canister bracket  |
| (2) Fuel delivery hose A | (14) Canister                   | (26) Evaporation hose B      |
| (3) Fuel filter bracket  | (15) Canister bracket plate     | (27) Roll over valve bracket |
| (4) Fuel filter holder   | (16) Cushion                    | (28) Roll over valve         |
| (5) Fuel filter cup      | (17) Canister bracket spacer    | (29) Evaporation hose C      |
| (6) Fuel filter          | (18) Rear canister bracket      | (30) Evaporation pipe        |
| (7) Evaporation hose A   | (19) Two-way valve return hose  | (31) Canister hose B         |
| (8) Fuel damper          | (20) Two-way valve              |                              |
| (9) Fuel delivery hose B | (21) Two-way valve drain hose A |                              |
| (10) Fuel return hose    | (22) Connector                  |                              |
| (11) Fuel pipe ASSY      | (23) Two-way valve drain hose B |                              |
| (12) Grommet             | (24) Clamp                      |                              |

---

***Tightening torque: N·m (kgf·m, ft·lb)***

***T1: 23 (2.34, 17.0)***

---

# GENERAL DESCRIPTION

Fuel Injection (Fuel Systems)

## 6. FUEL FILLER PIPE S185001A0506

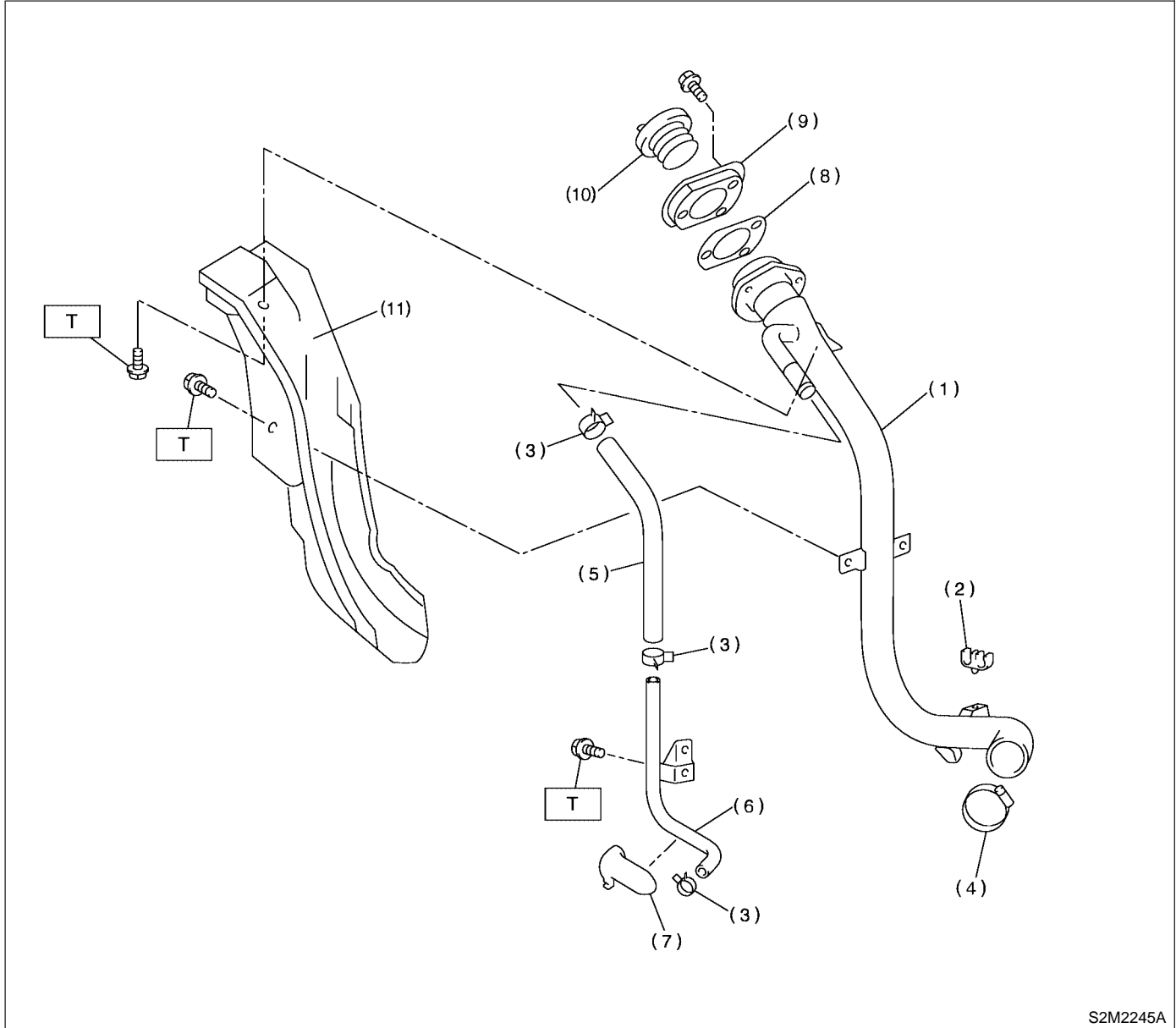

S2M2245A

- |                             |                          |                          |
|-----------------------------|--------------------------|--------------------------|
| (1) Fuel filter pipe ASSY   | (6) Air vent pipe        | (11) Fuel pipe protector |
| (2) Evaporation hose holder | (7) Air vent pipe holder |                          |
| (3) Clamp                   | (8) Filler pipe packing  |                          |
| (4) Clamp                   | (9) Filler ring          |                          |
| (5) Air vent hose           | (10) Filler cap          |                          |

**Tightening torque: N·m (kgf-m, ft-lb)**  
**T: 7.5 (0.76, 5.5)**

# GENERAL DESCRIPTION



Fuel Injection (Fuel Systems)

## C: CAUTION S185001A03

- Wear working clothing, including a cap, protective goggles, and protective shoes during operation.
- Remove contamination including dirt and corrosion before removal, installation or disassembly.
- Keep the disassembled parts in order and protect them from dust or dirt.
- Before removal, installation or disassembly, be sure to clarify the failure. Avoid unnecessary removal, installation, disassembly, and replacement.

- Be careful not to burn your hands, because each part on the vehicle is hot after running.
- Be sure to tighten fasteners including bolts and nuts to the specified torque.
- Place shop jacks or safety stands at the specified points.
- Before disconnecting electrical connectors of sensors or units, be sure to disconnect negative terminal from battery.
- Place "NO FIRE" signs near the working area.
- Be careful not to spill fuel on the floor.

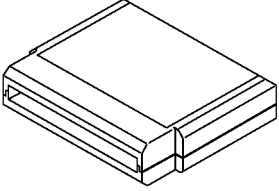
## D: PREPARATION TOOL S185001A17

ILLUSTRATION	TOOL NUMBER	DESCRIPTION	REMARKS
 <p style="text-align: center;">B2M3876</p>	<p style="text-align: center;">24082AA150 (Newly adopted tool)</p>	CARTRIDGE	Troubleshooting for electrical system.
 <p style="text-align: center;">B2M3877</p>	<p style="text-align: center;">22771AA030</p>	SELECT MONITOR KIT	<p>Troubleshooting for electrical systems.</p> <ul style="list-style-type: none"> <li>● English: 22771AA030 (Without printer)</li> <li>● German: 22771AA070 (Without printer)</li> <li>● French: 22771AA080 (Without printer)</li> <li>● Spanish: 22771AA090 (Without printer)</li> </ul>

# THROTTLE BODY

Fuel Injection (Fuel Systems)

## 2. Throttle Body S185010

### A: REMOVAL S185010A18

1) Disconnect battery ground cable.

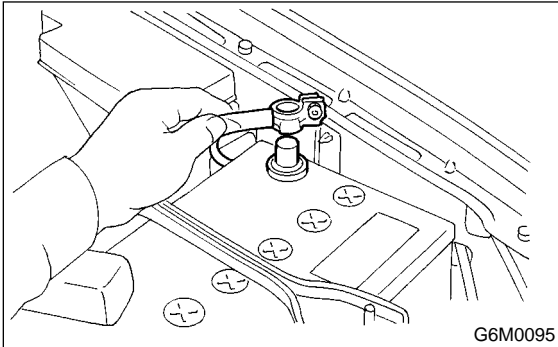

2) Remove intercooler. <Ref. to IN(DOHC TURBO)-10, REMOVAL, Intercooler.>

3) Disconnect connector from throttle position sensor (A) and idle air control solenoid valve (B) and pressure sensor (C).

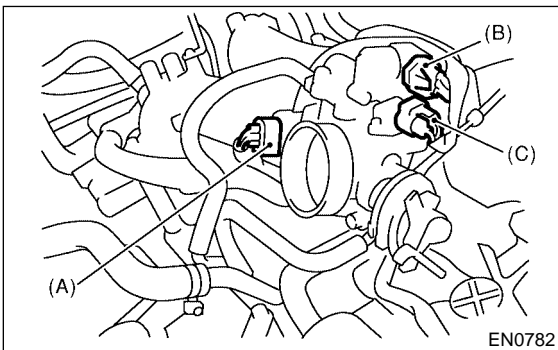

4) Disconnect accelerator cable.

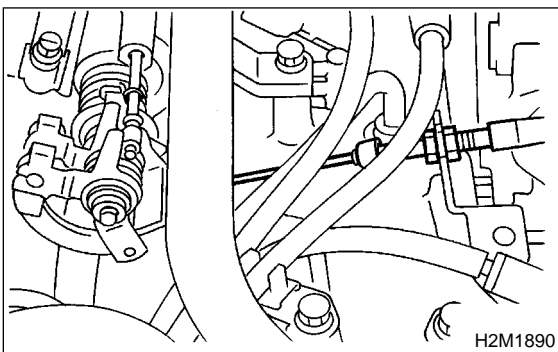

5) Disconnect engine coolant hoses from throttle body.

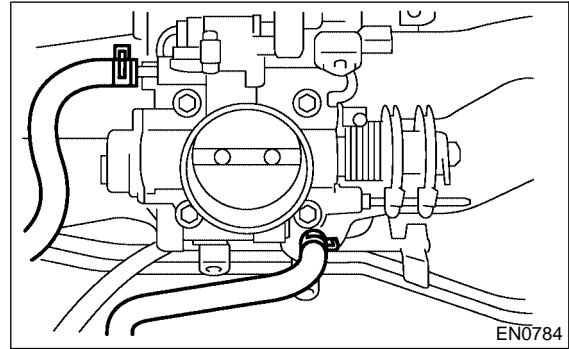

6) Remove bolts which secure throttle body to intake manifold.

### B: INSTALLATION S185010A11

Install in the reverse order of removal.

NOTE:

Always use new gaskets.

**Tightening torque:**

**22 N·m (2.2 kgf-m, 15.9 ft-lb)**

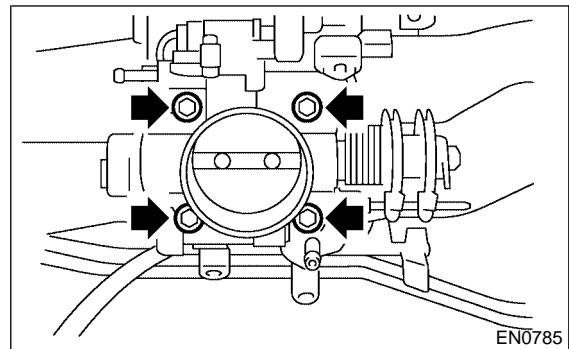

## 3. Intake Manifold S185034

### A: REMOVAL S185034A18

- 1) Release fuel pressure. <Ref. to FU(DOHC TURBO)-50, RELEASING OF FUEL PRESSURE, OPERATION, Fuel.>
- 2) Disconnect battery ground cable.

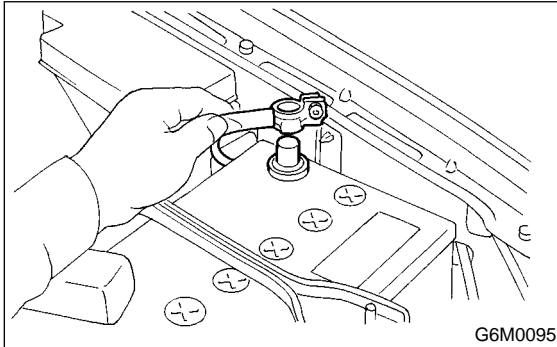

- 3) Lift up vehicle.
- 4) Remove under cover.
- 5) Drain coolant about 3.0 ℓ (3.2 US qt, 2.6 Imp qt).

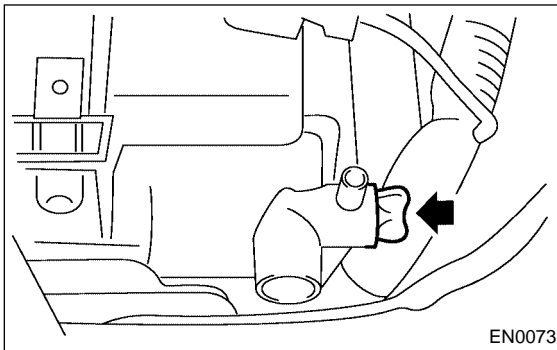

- 6) Remove air cleaner upper cover and air intake boot. <Ref. to IN(DOHC TURBO)-7, REMOVAL, Air Cleaner.>
- 7) Remove air cleaner element.
- 8) Remove intercooler. <Ref. to IN(DOHC TURBO)-10, REMOVAL, Intercooler.>
- 9) Disconnect accelerator cable.

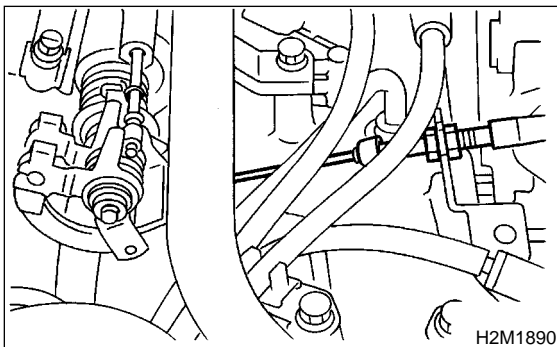

- 10) Remove coolant filler tank. <Ref. to CO-37, REMOVAL, Coolant Filler Tank.>
- 11) Remove power steering pump from bracket.

- (1) Remove front side V-belt. <Ref. to ME(DOHC TURBO)-44, REMOVAL, V-belt.>
- (2) Disconnect the power steering switch connector.

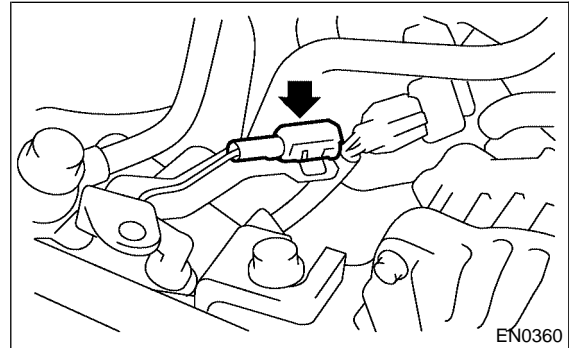

- (3) Remove bolts which secure power steering pipe brackets to intake manifold.

**NOTE:**  
Do not disconnect power steering hose.

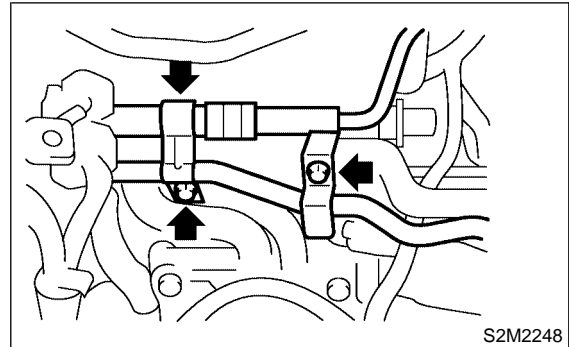

- (4) Remove bolts which secure power steering pump.

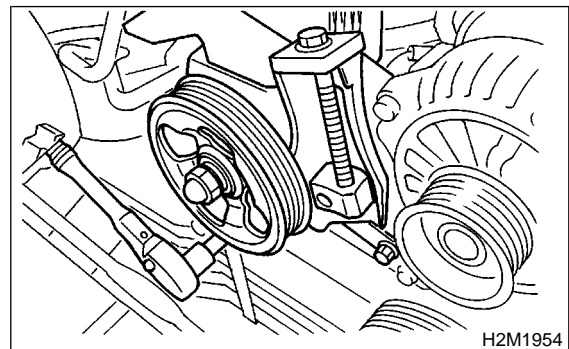



# INTAKE MANIFOLD

## Fuel Injection (Fuel Systems)

(5) Remove power steering tank from the bracket by pulling it upward.

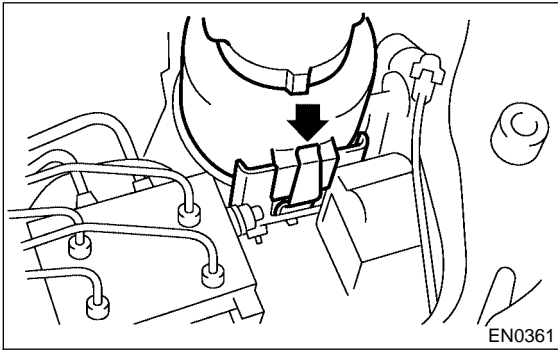

(6) Place power steering pump on the right side wheel apron.

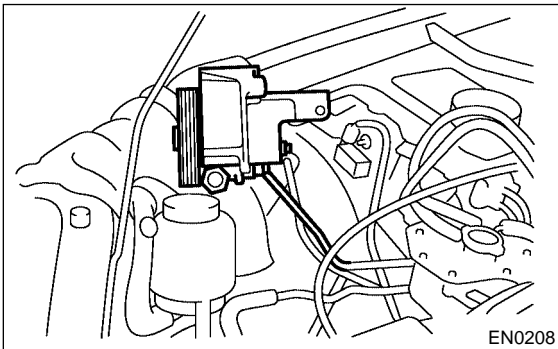

12) Disconnect emission hose from PCV valve.

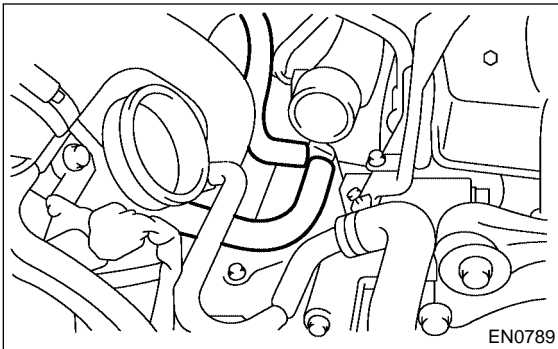

13) Disconnect engine coolant hoses from throttle body.

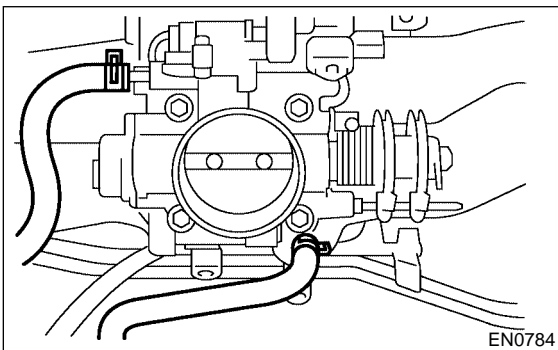

14) Disconnect brake booster hose.

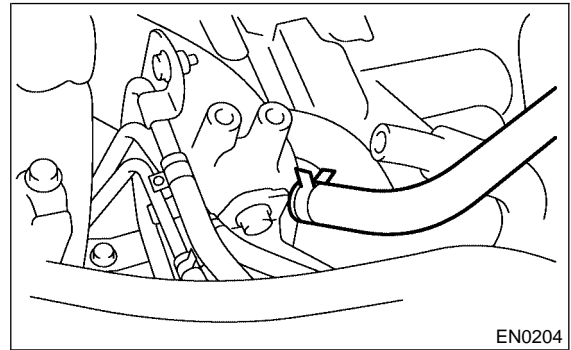

15) Disconnect Pressure hose from intake duct.

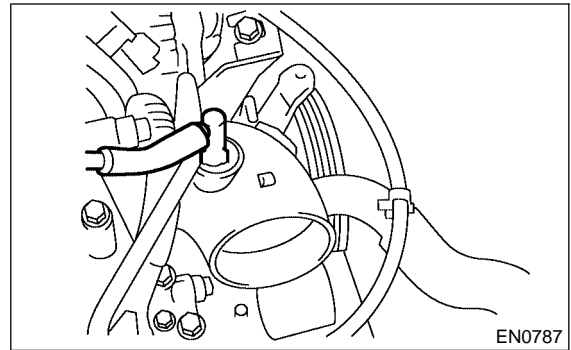

16) Disconnect engine harness connectors from bulkhead harness connectors.

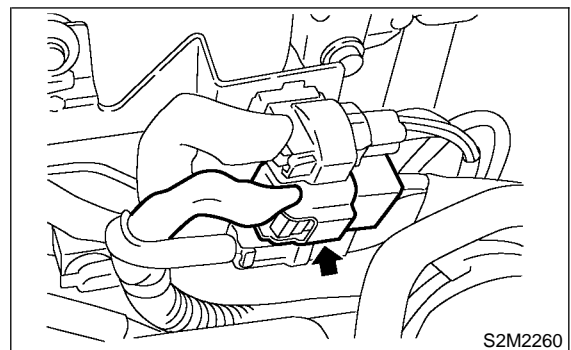
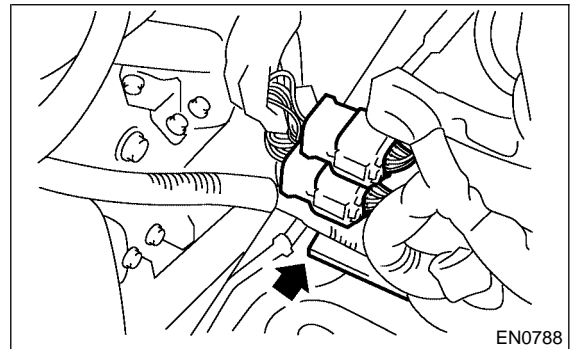

# INTAKE MANIFOLD

Fuel Injection (Fuel Systems)

17) Disconnect connectors from engine coolant temperature sensor (A), oil pressure switch (B) and crankshaft position sensor (C).

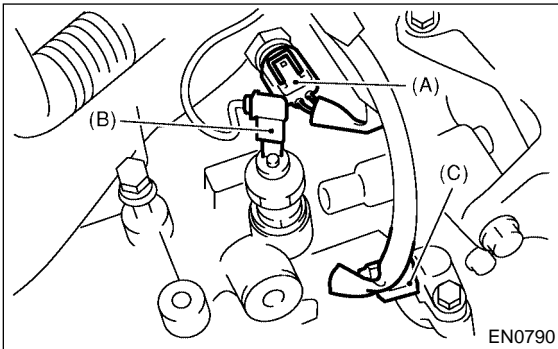

18) Disconnect knock sensor connector.

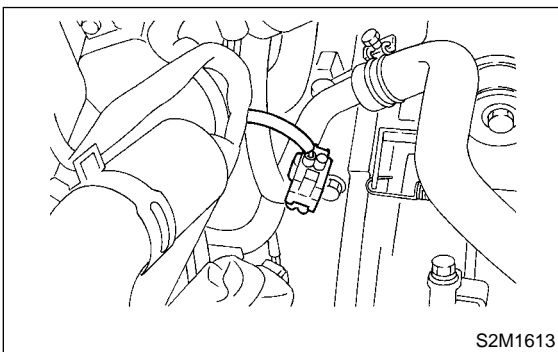

19) Disconnect connector from camshaft position sensor.

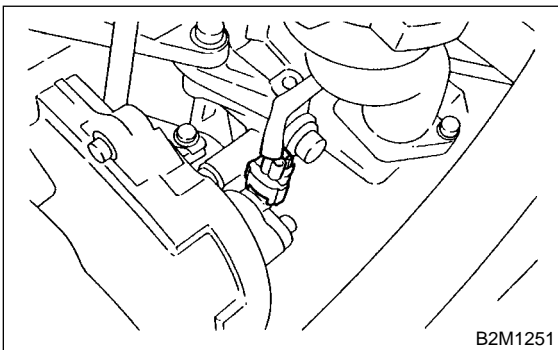

20) Disconnect connector from ignition coil.

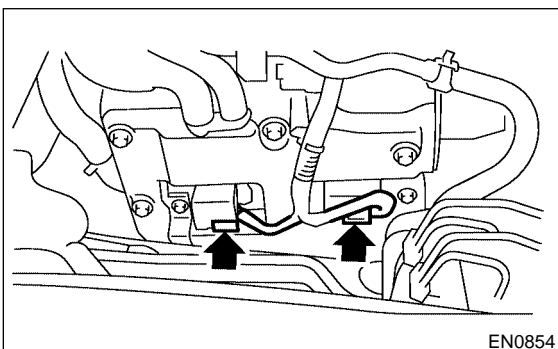

21) Remove harness secured by clip (A) from the bracket.

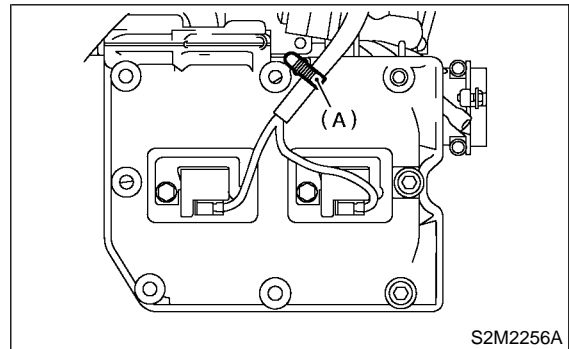

22) Disconnect fuel delivery hose, return hose and evaporation hose.

**WARNING:**  
Catch fuel from hoses in a container.

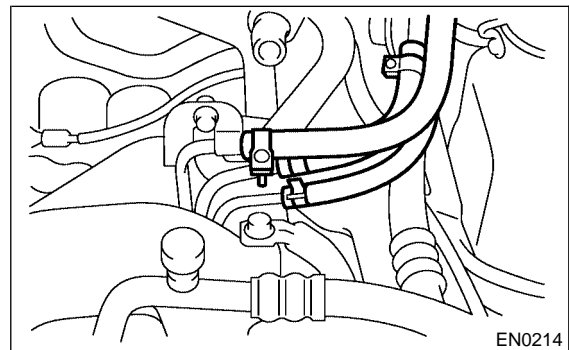

23) Remove bolts which secure intake manifold to cylinder heads.

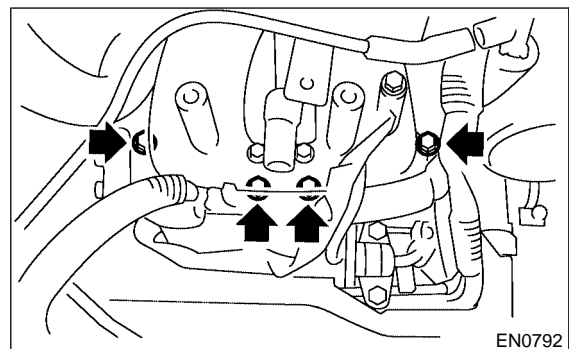

24) Remove intake manifold.

## B: INSTALLATION S185034A11

1) Install intake manifold onto cylinder heads.

**NOTE:**  
Always use new gaskets.

# INTAKE MANIFOLD

Fuel Injection (Fuel Systems)

**Tightening torque:**  
**25 N·m (2.5 kgf-m, 18.1 ft-lb)**

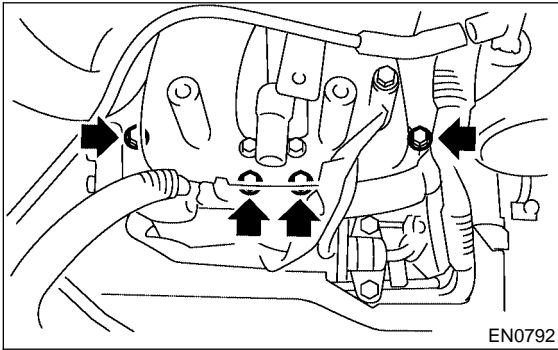

2) Connect fuel delivery hose, return hose, and evaporation hose.

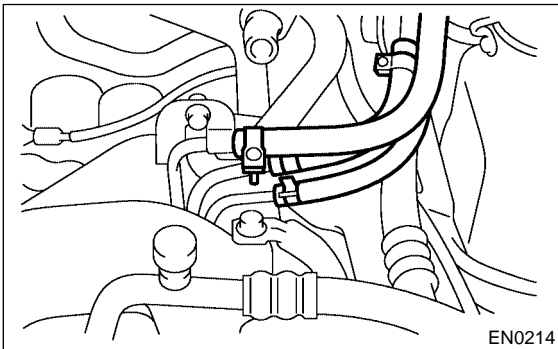

3) Connect connector to oil pressure switch (B), crankshaft position sensor (C) and engine coolant temperature sensor (A).

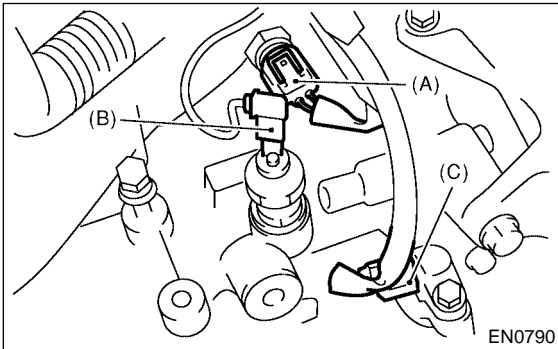

4) Connect connector to knock sensor.

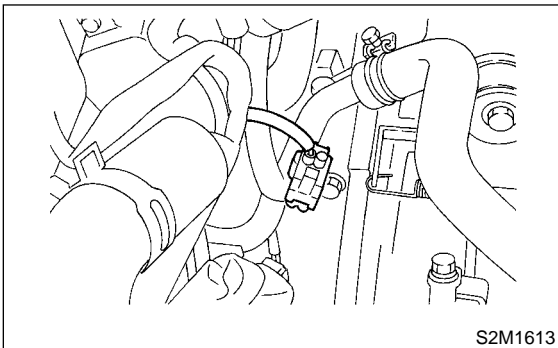

5) Connect connector to camshaft position sensor.

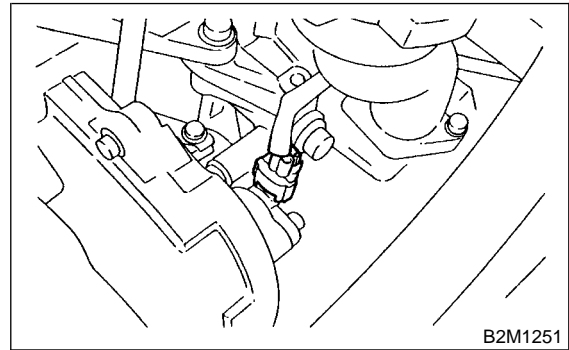

6) Connect connector to ignition coil.

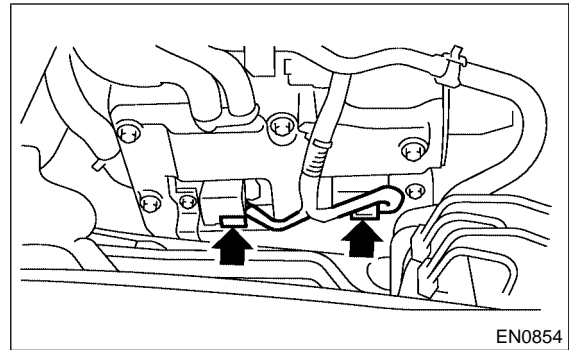

7) Secure harness to the bracket with clip (A).

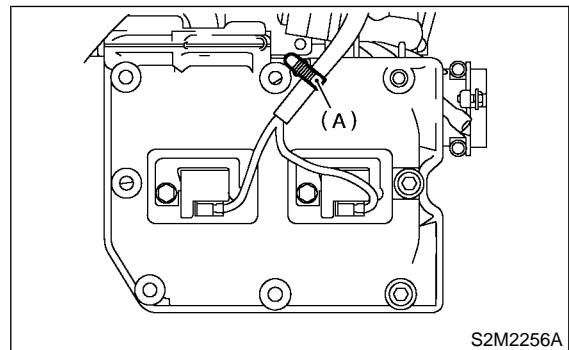

# INTAKE MANIFOLD

Fuel Injection (Fuel Systems)

8) Connect engine harness connector to bulkhead harness connectors.

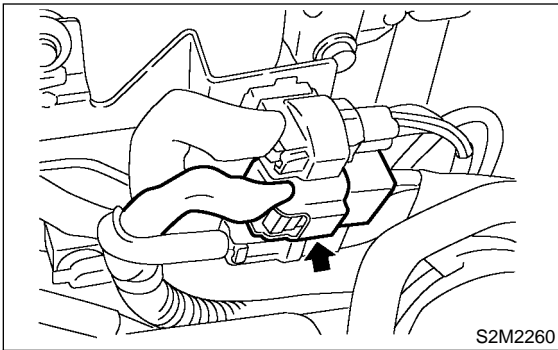
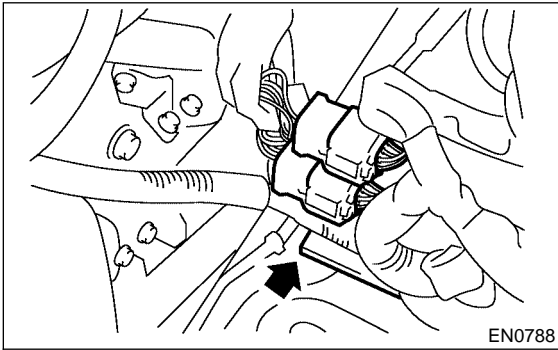

9) Connect brake booster vacuum hose.

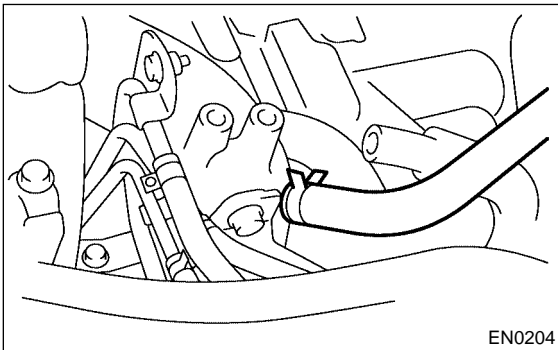

10) Connect engine coolant hoses to throttle body.

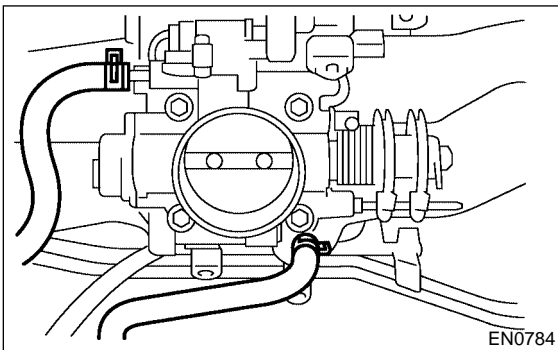

11) Connect emission hose to PCV valve.

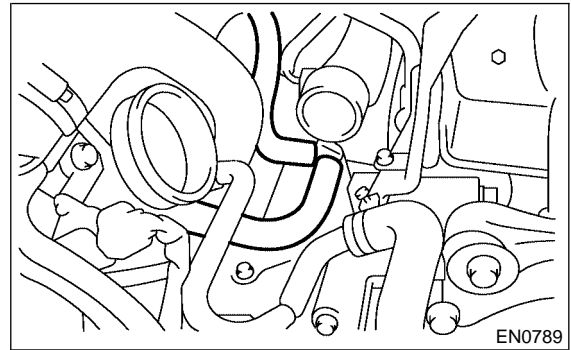

12) Connect pressure hose to intake duct.

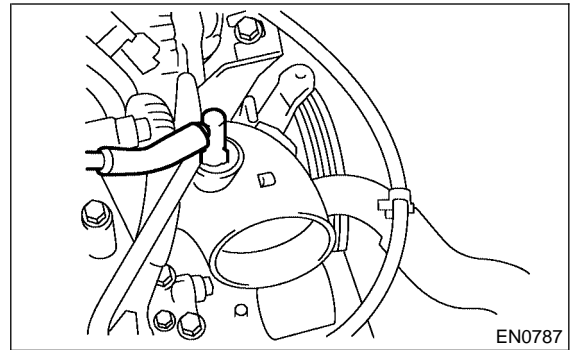

13) Install power steering pump on bracket.  
(1) Install power steering tank on bracket.

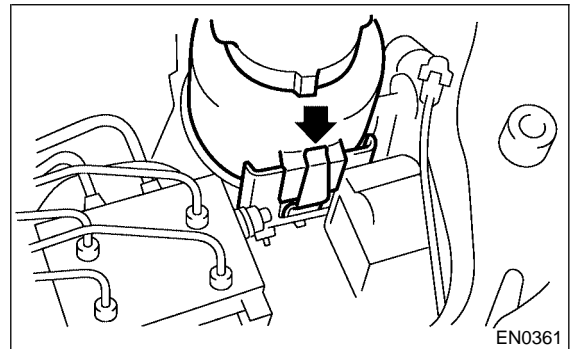

(2) Connect connector to power steering pump switch.

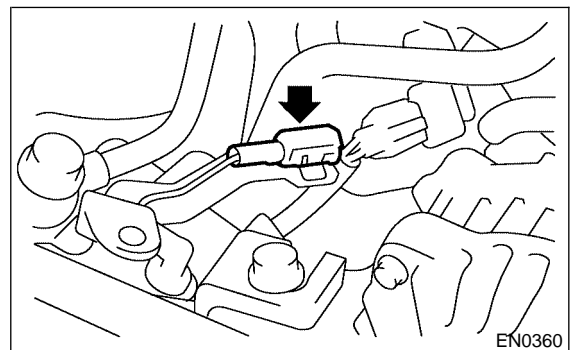

# INTAKE MANIFOLD

## Fuel Injection (Fuel Systems)

- (3) Install power steering pump, and tighten bolts.

### Tightening torque:

**20.1 N·m (2.05 kgf·m, 14.8 ft·lb)**

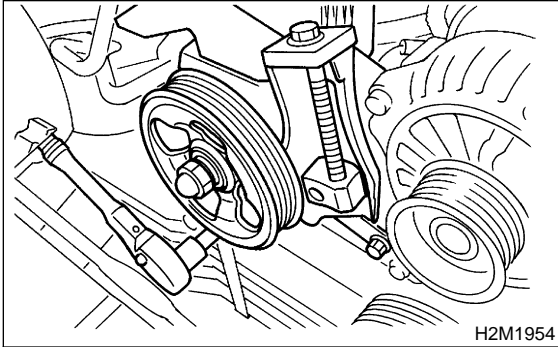

- (4) Install power steering pipe brackets on right side intake manifold.

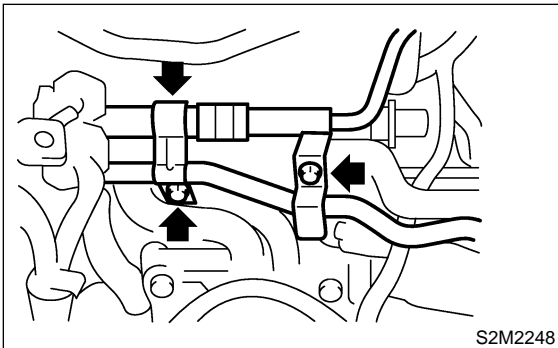

- (5) Install front side V-belt. <Ref. to ME(DOHC TURBO)-44, INSTALLATION, V-belt.>

- 14) Install coolant filler tank. <Ref. to CO-37, INSTALLATION, Coolant Filler Tank.>

- 15) Connect accelerator cable.

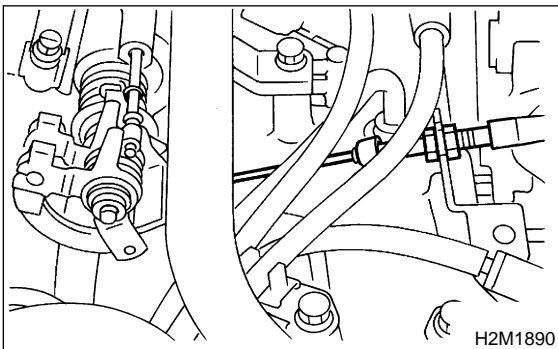

- 16) Install intercooler. <Ref. to IN(DOHC TURBO)-10, INSTALLATION, Intercooler.>

- 17) Install air cleaner element.

- 18) Install air cleaner upper cover and air intake duct as a unit. <Ref. to IN(DOHC TURBO)-7, INSTALLATION, Air Cleaner.>

- 19) Connect connector to fuel pump relay.

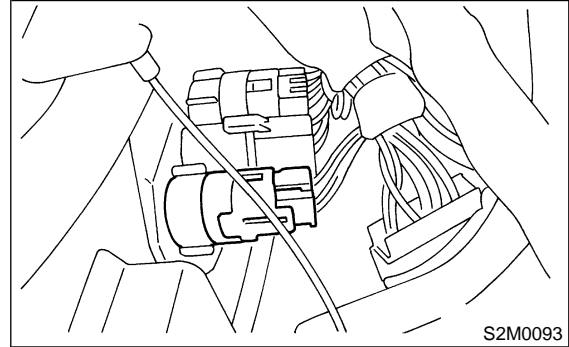

- 20) Connect battery ground cable.

- 21) Lift up vehicle.

- 22) Install under cover.

- 23) Fill coolant. <Ref. to CO-14, FILLING OF ENGINE COOLANT, REPLACEMENT, Engine Coolant.>

## C: DISASSEMBLY S185034A06

1) Remove fuel pipe protector.

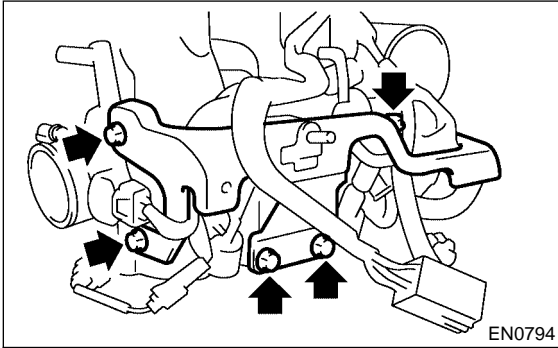

2) Remove engine ground terminal from intake manifold.

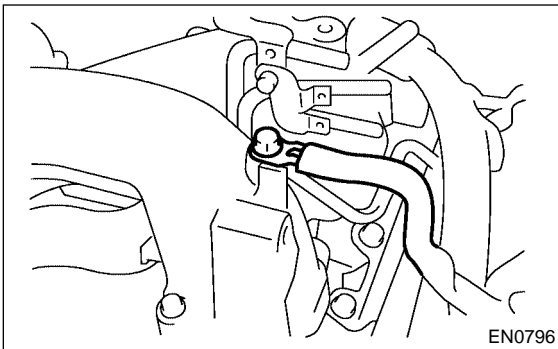
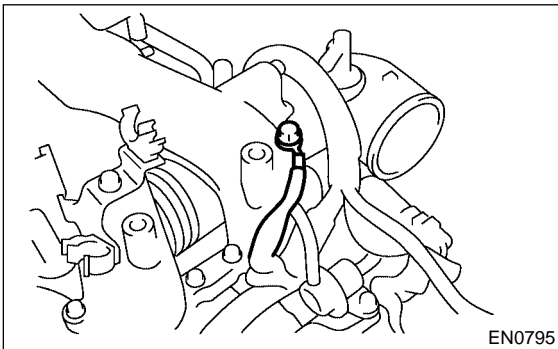

3) Disconnect connector from throttle position sensor (A), idle air control solenoid valve (B) and pressure sensor (C).

4) Separate engine harness secured to the intake manifold by clip (D).

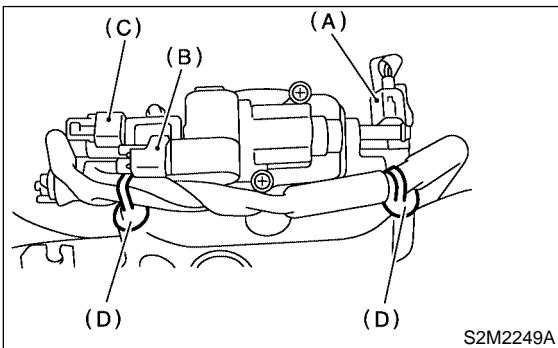

5) Remove throttle body from intake manifold.

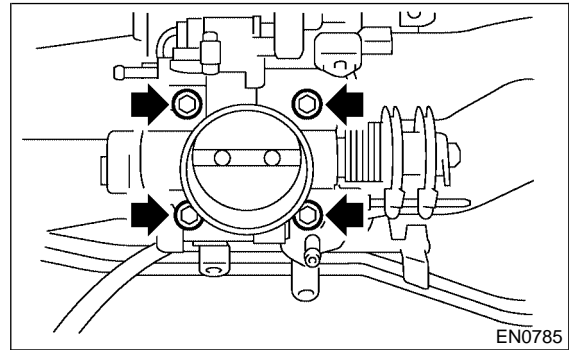

6) Disconnect connector from fuel injector.

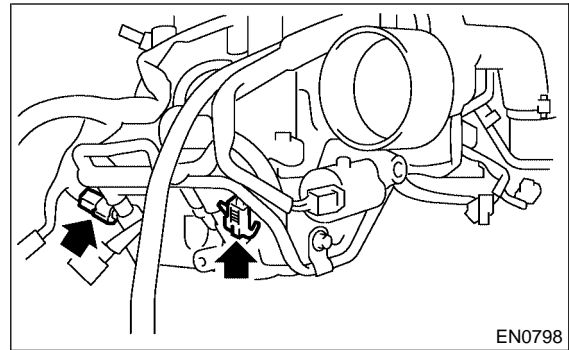

7) Disconnect connector from tumble generator valve actuator.

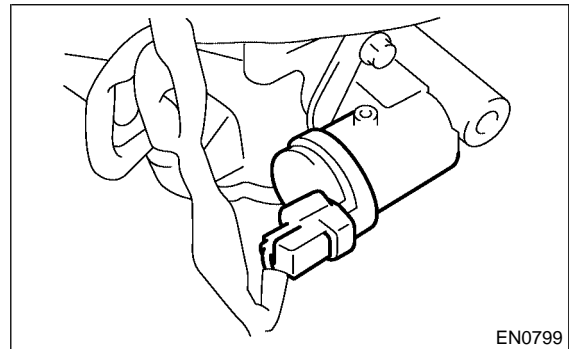

8) Disconnect connector from tumble generator valve sensor.

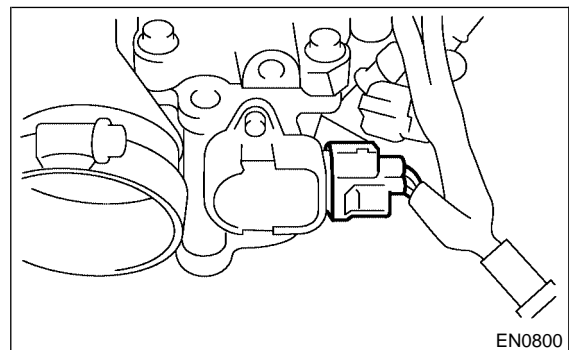

# INTAKE MANIFOLD

## Fuel Injection (Fuel Systems)

9) Disconnect connector from purge control solenoid valve.

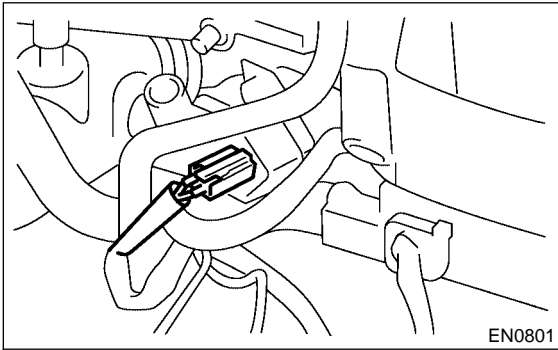

10) Remove purge control solenoid valve.

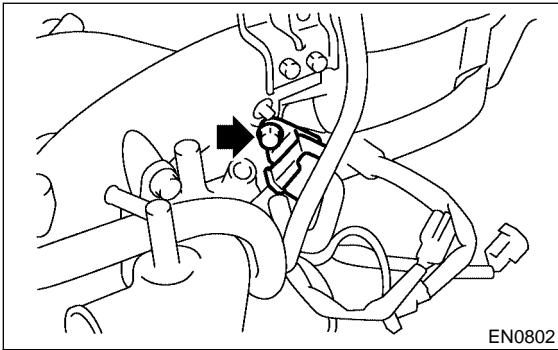

11) Disconnect evaporation hose from intake manifold.

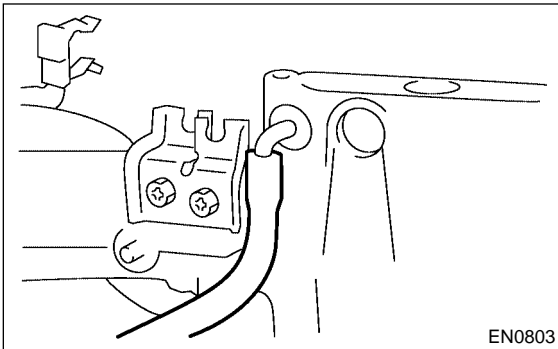

12) Disconnect evaporation hoses from purge valve.

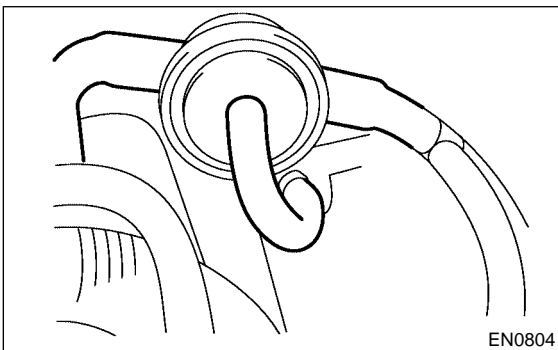

13) Remove two bolts which hold fuel pipes on the left side of intake manifold.

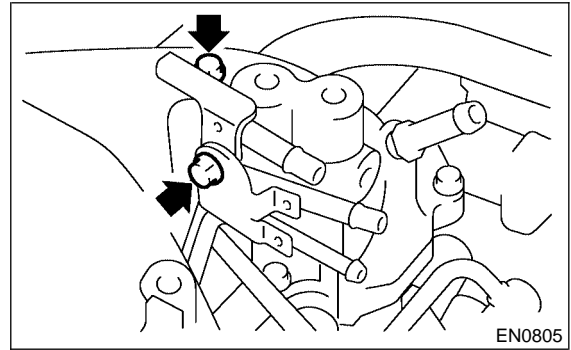

14) Remove bolt which hold fuel injector pipe onto intake manifold.

● LH SIDE

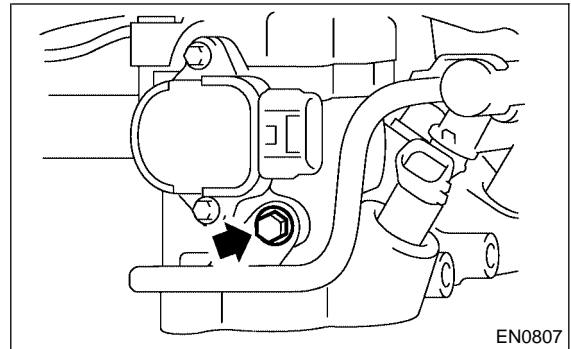
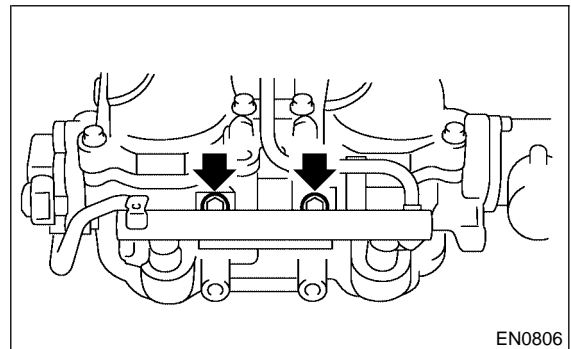

# INTAKE MANIFOLD

Fuel Injection (Fuel Systems)

## ● RH SIDE

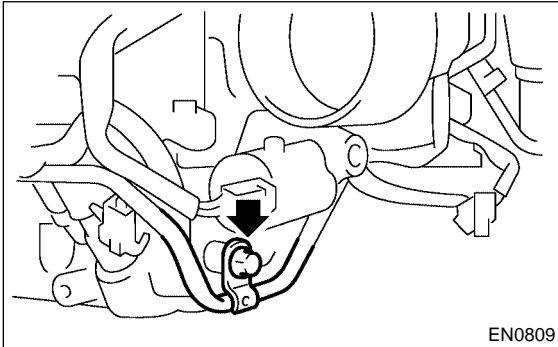
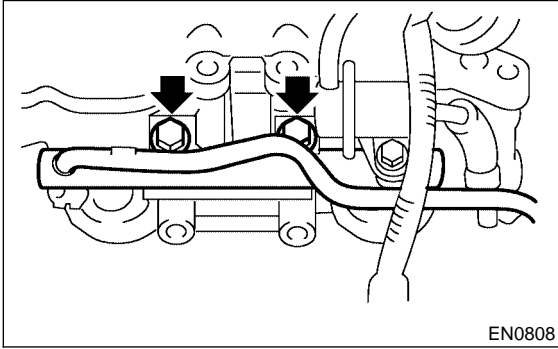

15) Remove fuel injector.

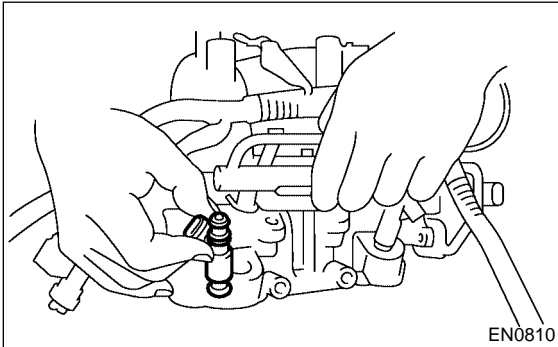

16) Remove harness bracket which hold engine harness onto intake manifold.

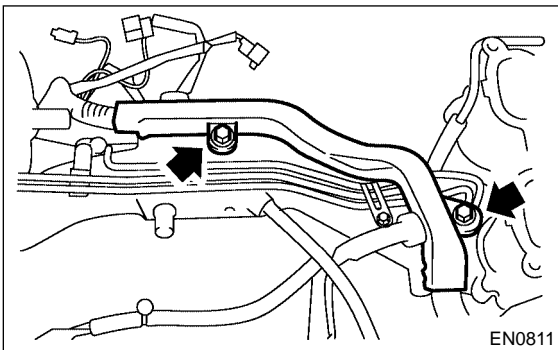

17) Remove engine harness from intake manifold.

18) Loosen clamp which holds front left side fuel hose to injector pipe and remove the pipe from clamp.

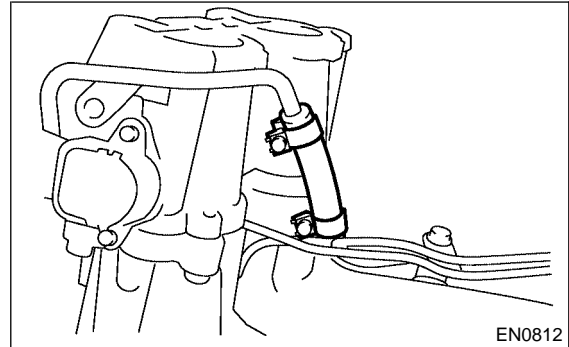

19) Remove fuel injector pipe LH.

20) Remove bolts which installs fuel pipe on intake manifold.

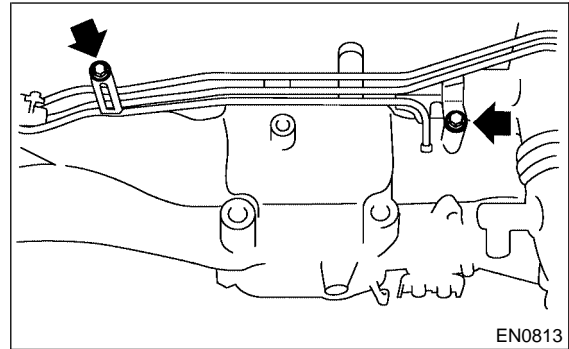

21) Remove fuel pipe assembly and pressure regulator, from intake manifold.

22) Remove intake duct from intake manifold.

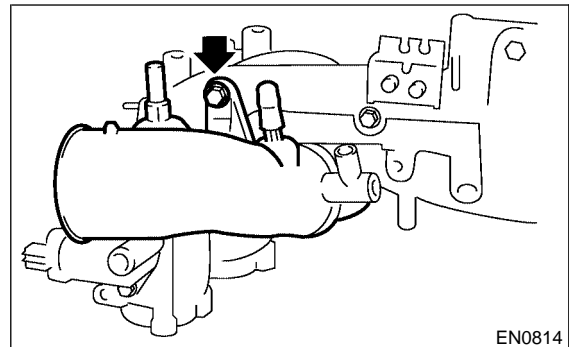



# INTAKE MANIFOLD

## Fuel Injection (Fuel Systems)

23) Remove tumble generator valve assembly from intake manifold.

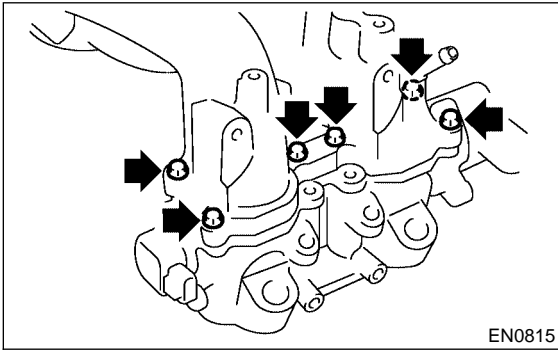

## D: ASSEMBLY S185034A02

### NOTE:

Replace gasket with a new one.

1) Install tumble generator valve assembly to intake manifold.

### Tightening torque:

**8.25 N·m (0.84 kgf-m, 6.08 ft-lb)**

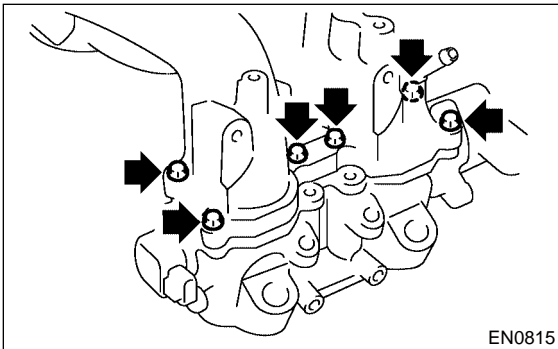

2) Install air intake duct to intake manifold.

### Tightening torque:

**19 N·m (1.94 kgf-m, 14.0 ft-lb)**

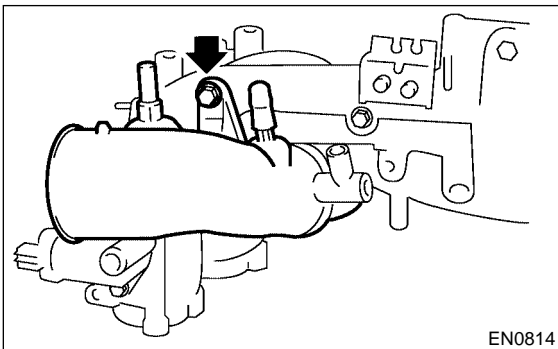

3) Install fuel pipe assembly and pressure regulator, to intake manifold.

### Tightening torque:

**5 N·m (0.51 kgf-m, 3.69 ft-lb)**

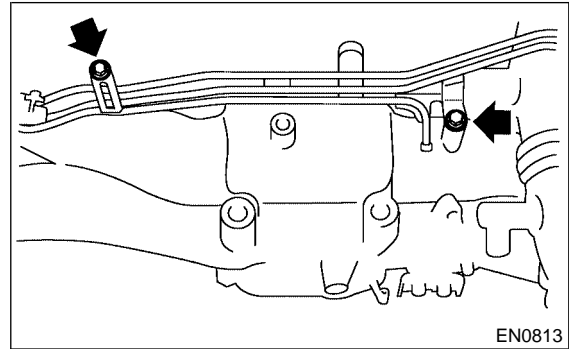

4) Install fuel injector pipe LH.

5) Connect left side fuel hose to injector pipe, and tighten clamp screw.

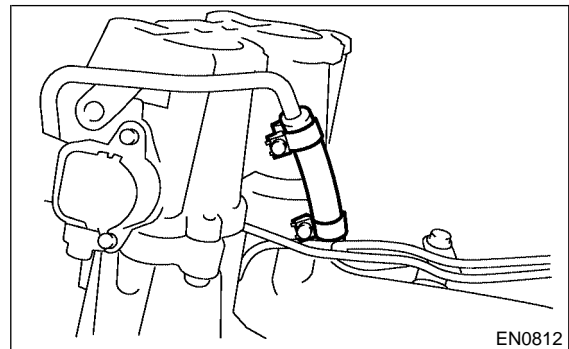

6) Install engine harness to intake manifold.

7) Install harness bracket which hold engine harness onto intake manifold.

### Tightening torque:

**19 N·m (1.94 kgf-m, 14.0 ft-lb)**

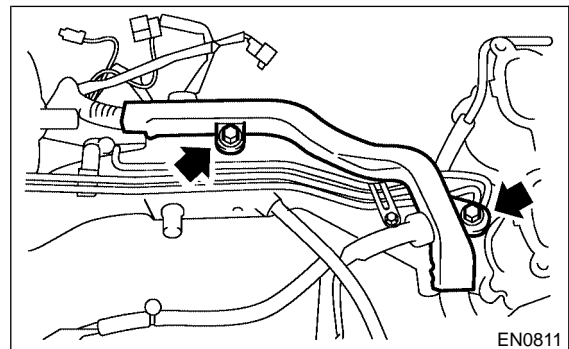

# INTAKE MANIFOLD

Fuel Injection (Fuel Systems)

8) Install fuel injector.

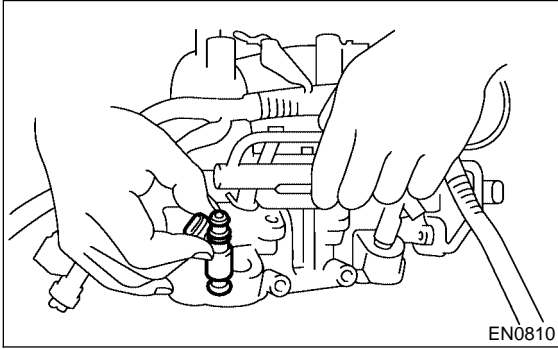

9) Tighten bolt which install fuel injector pipe onto intake manifold.

**Tightening torque:**

**19 N·m (1.94 kgf-m, 14.0 ft-lb)**

● LH SIDE

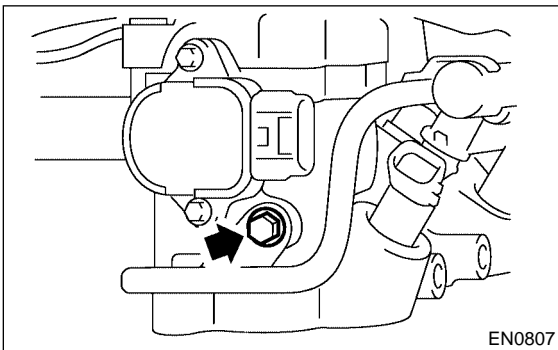
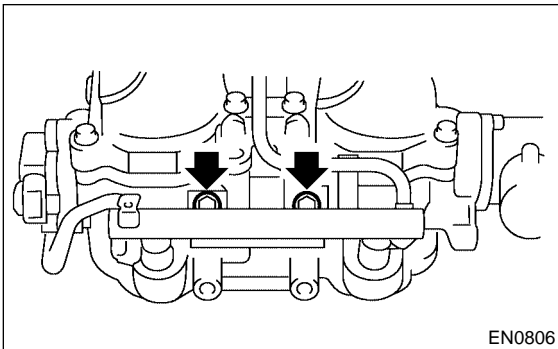

● RH SIDE

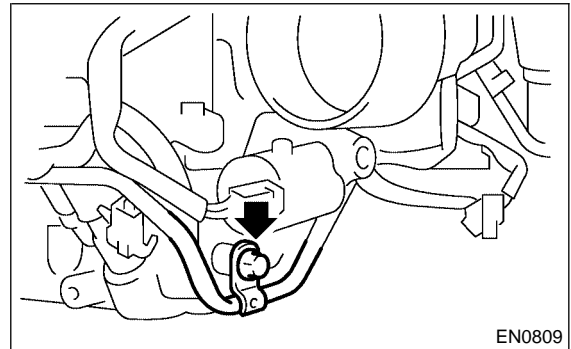
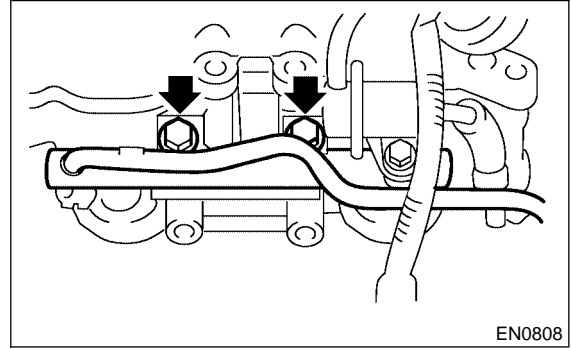

10) Tighten two bolts which install fuel pipes on the left side of intake manifold.

**Tightening torque:**

**5 N·m (0.51 kgf-m, 3.69 ft-lb)**

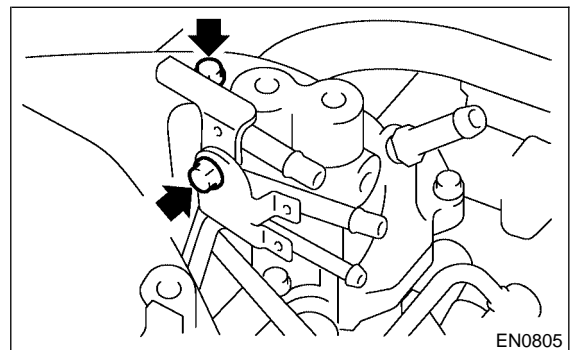

# INTAKE MANIFOLD

Fuel Injection (Fuel Systems)

11) Connect evaporation hoses to purge valve.

**CAUTION:**

**Carefully connect the evaporation hoses.**

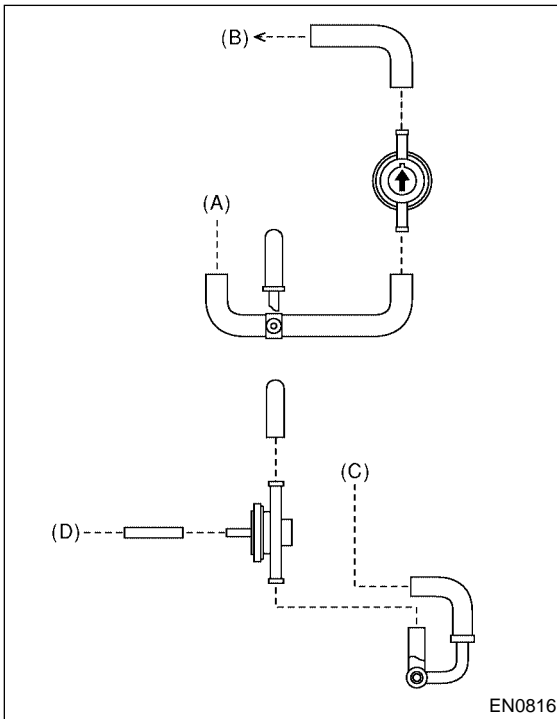

- (A) To fuel pipe ASSY
- (B) To intake duct
- (C) To purge control solenoid valve
- (D) To intake manifold

12) Connect evaporation hose to intake manifold.

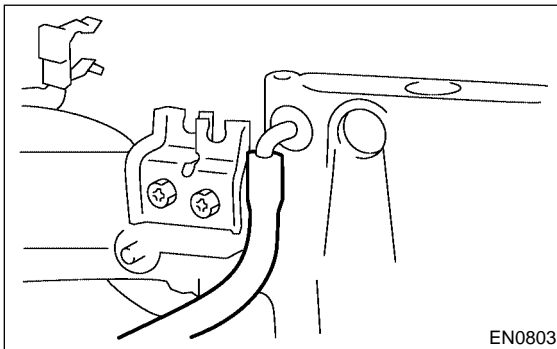

13) Install purge control solenoid valve.

**Tightening torque:**

**16 N·m (0.16 kgf·m, 1.2 ft·lb)**

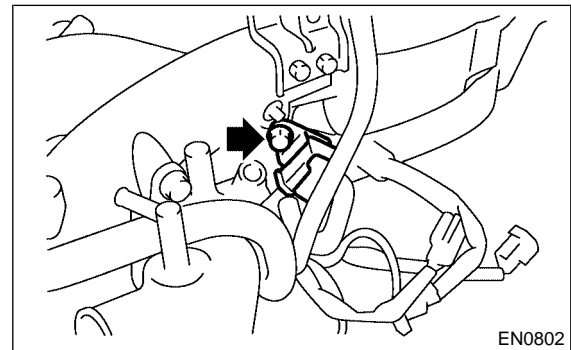

14) Connect hoses to purge control solenoid valve.

**CAUTION:**

**Carefully connect the evaporation hoses.**

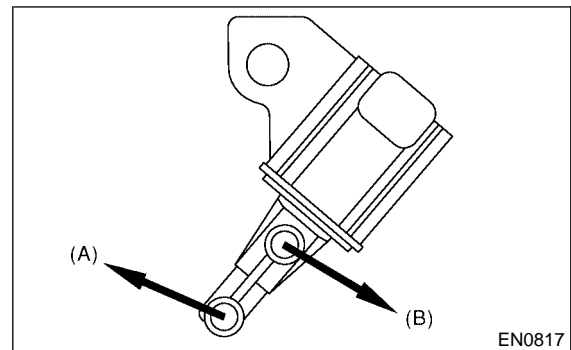

- (A) To intake manifold
- (B) To purge valve

15) Connect connector to purge control solenoid valve.

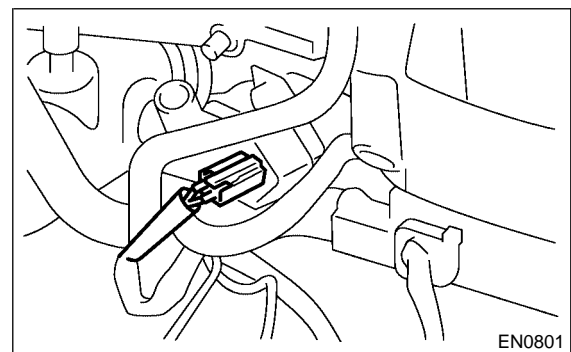

# INTAKE MANIFOLD

Fuel Injection (Fuel Systems)

- 16) Connect connector to tumble generator valve sensor.

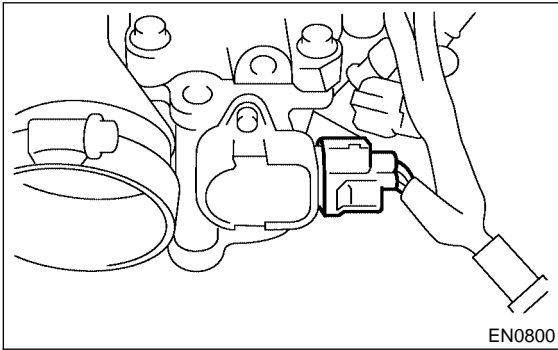

- 17) Connect connector to tumble generator valve actuator.

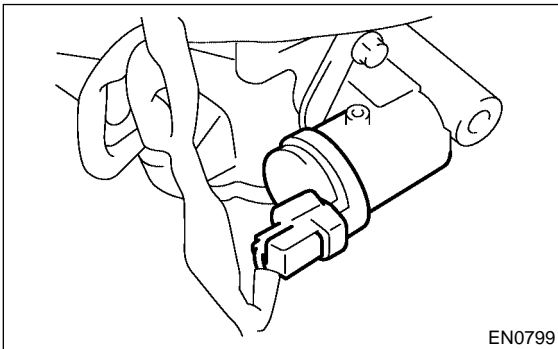

- 18) Connect connector to fuel injector.

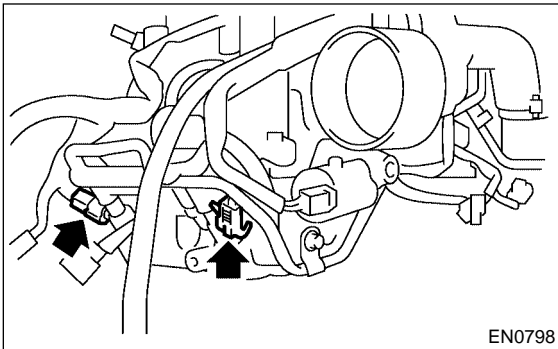

- 19) Install throttle body to intake manifold.

NOTE:

Replace gasket with a new one.

**Tightening torque:**

**22 N·m (2.2 kgf·m, 16 ft·lb)**

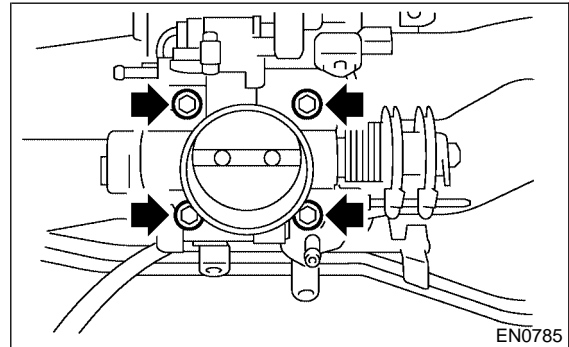

- 20) Connect connector to throttle position sensor (A), idle air control solenoid valve (B) and pressure sensor (C).

- 21) Secure engine harness to the intake manifold with clip (D).

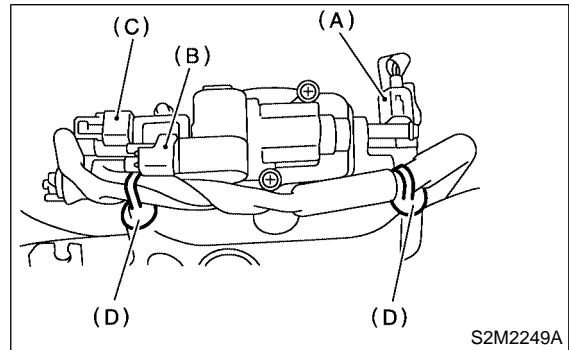

- 22) Install engine ground terminal to intake manifold.

**Tightening torque:**

**19 N·m (1.94 kgf·m, 14.0 ft·lb)**

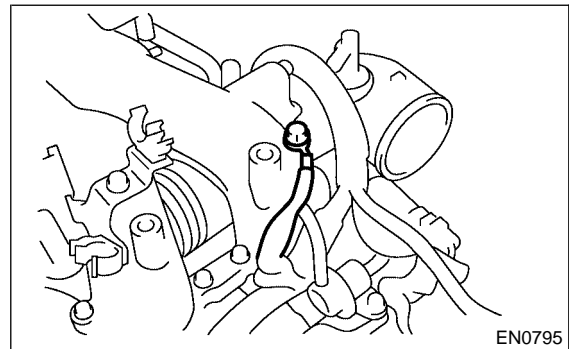

# INTAKE MANIFOLD

Fuel Injection (Fuel Systems)

---

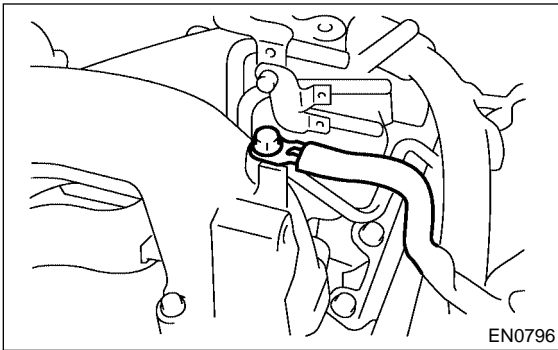

23) Install fuel pipe protector.

**Tightening torque:**

**19 N·m (1.94 kgf·m, 14.0 ft·lb)**

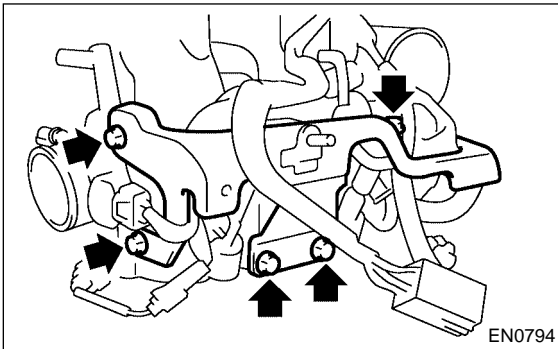

## E: INSPECTION

S185034A10

Make sure the fuel pipe and fuel hoses are not cracked and that connections are tight.

## 4. Engine Coolant Temperature Sensor

S185047

### A: REMOVAL

S185047A18

- 1) Disconnect battery ground cable.

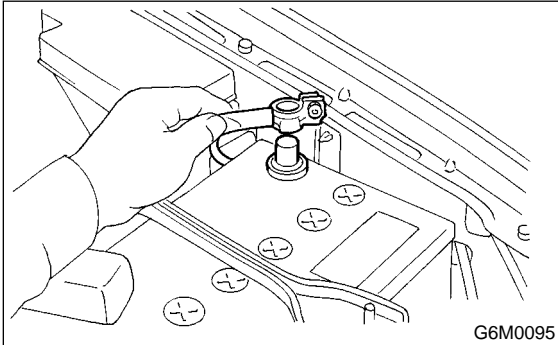

- 2) Remove the generator <Ref. to SC-12, REMOVAL, Generator.>
- 3) Disconnect connector from engine coolant temperature sensor.

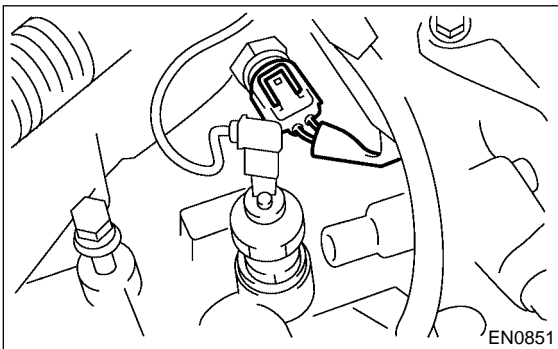

- 4) Remove engine coolant temperature sensor.

### B: INSTALLATION

S185047A11

Install in the reverse order of removal.

**Tightening torque:**

**18 N·m (1.8 kgf-m, 13 ft-lb)**

# CRANKSHAFT POSITION SENSOR

Fuel Injection (Fuel Systems)

## 5. Crankshaft Position Sensor

S185043

### A: REMOVAL S185043A18

- 1) Disconnect battery ground cable.

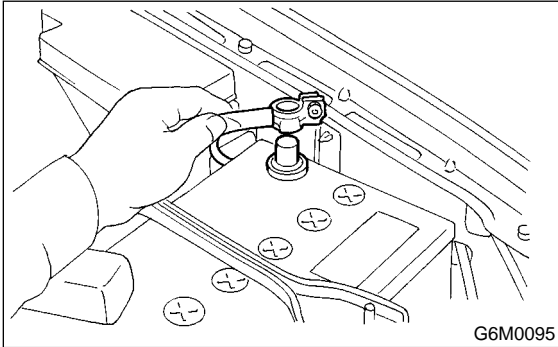

- 2) Remove bolt which install crankshaft position sensor to cylinder block.

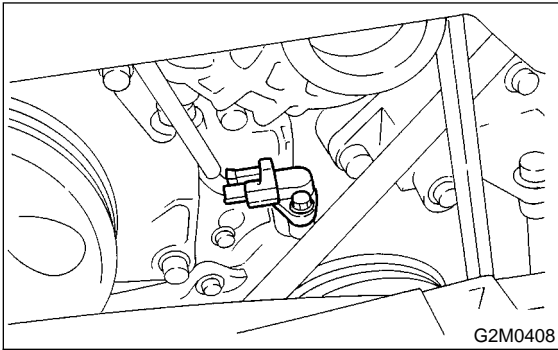

- 3) Remove crankshaft position sensor, and disconnect connector from it.

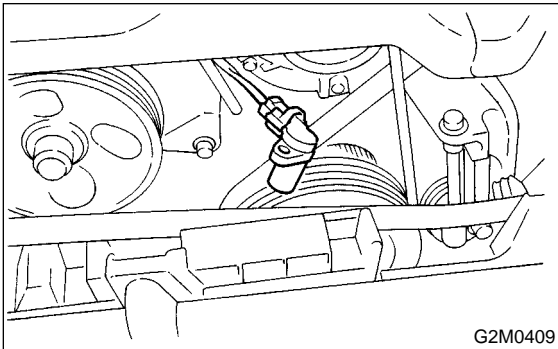

### B: INSTALLATION S185043A11

Install in the reverse order of removal.

**Tightening torque:**

**T: 6.4 N·m (0.65 kgf·m, 4.7 ft·lb)**

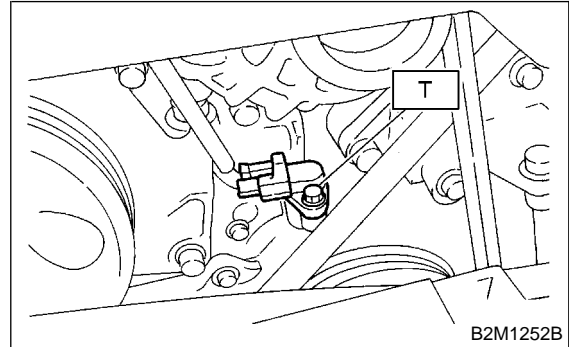

## 6. Camshaft Position Sensor

S185041

### A: REMOVAL S185041A18

- 1) Disconnect battery ground cable.

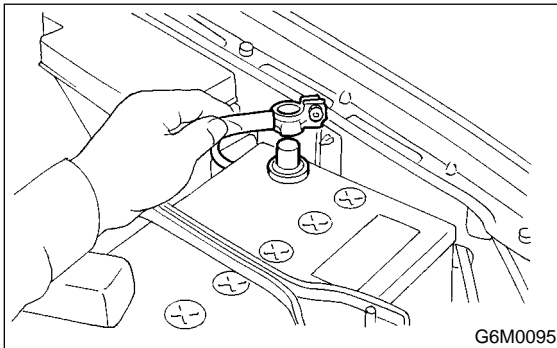

- 2) Disconnect connector from camshaft position sensor.

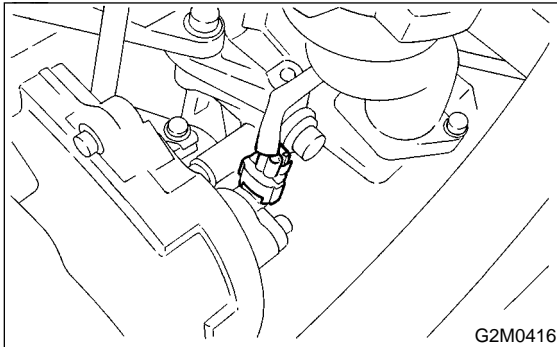

- 3) Remove camshaft position sensor from camshaft support LH.

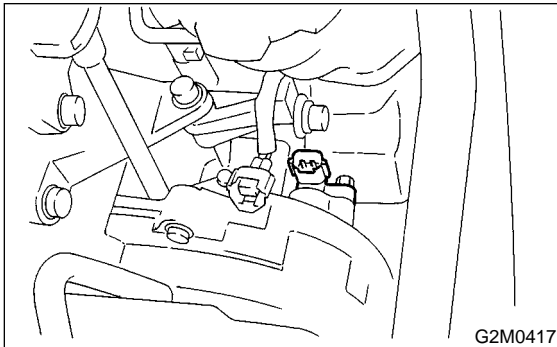

### B: INSTALLATION S185041A11

Install in the reverse order of removal.

**Tightening torque:**

**T: 6.4 N·m (0.65 kgf·m, 4.7 ft·lb)**

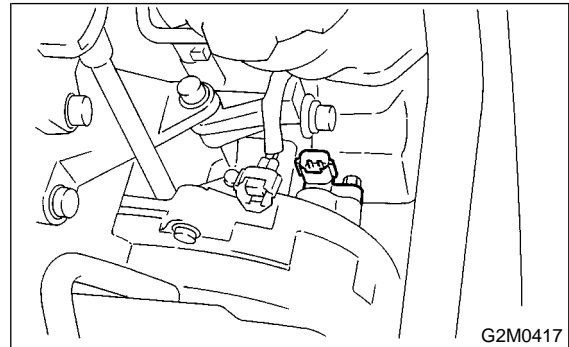



# KNOCK SENSOR

Fuel Injection (Fuel Systems)

## 7. Knock Sensor S185042

### A: REMOVAL S185042A18

- 1) Disconnect battery ground cable from battery ground terminal.

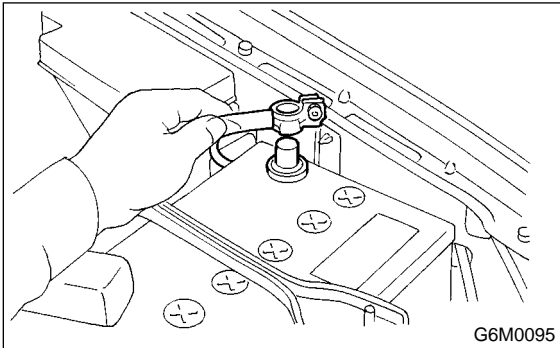

- 2) Remove intercooler. <Ref. to IN(DOHC TURBO)-10, REMOVAL, Intercooler.>
- 3) Disconnect knock sensor connector.

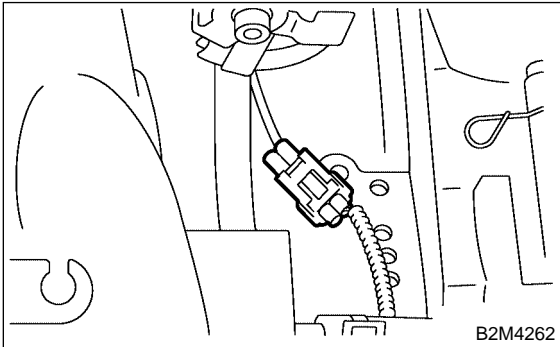

- 4) Remove knock sensor from cylinder block.

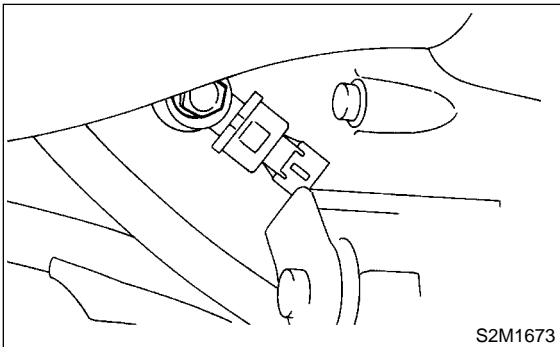

### B: INSTALLATION S185042A11

- 1) Install knock sensor to cylinder block.

**Tightening torque:**

**24 N·m (2.4 kgf·m, 17.4 ft·lb)**

**NOTE:**

The extraction area of the knock sensor cord must be positioned at a 60° angle relative to the engine rear.

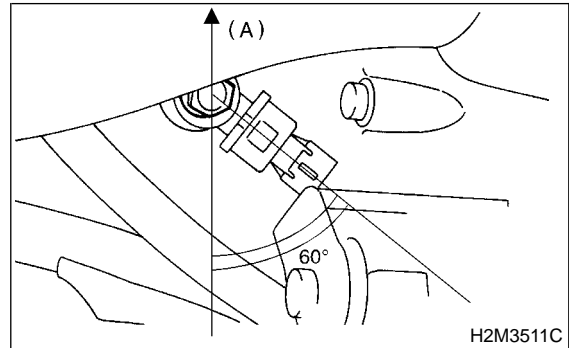

- 2) Connect knock sensor connector.

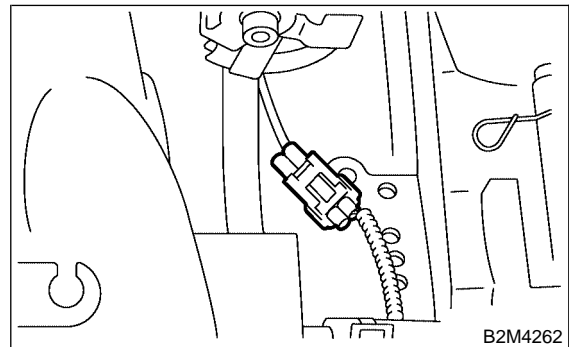

- 3) Install intercooler. <Ref. to IN(DOHC TURBO)-10, INSTALLATION, Intercooler.>
- 4) Connect battery ground cable.

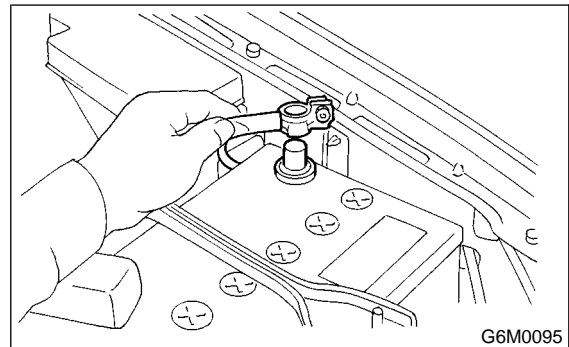

## 8. Throttle Position Sensor S185039

### A: REMOVAL S185039A18

- 1) Disconnect battery ground cable.

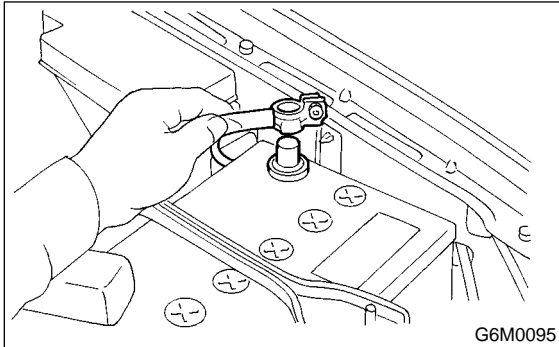

- 2) Remove inter cooler. <Ref. to IN(DOHC TURBO)-10, REMOVAL, Intercooler.>
- 3) Disconnect connector from throttle position sensor.

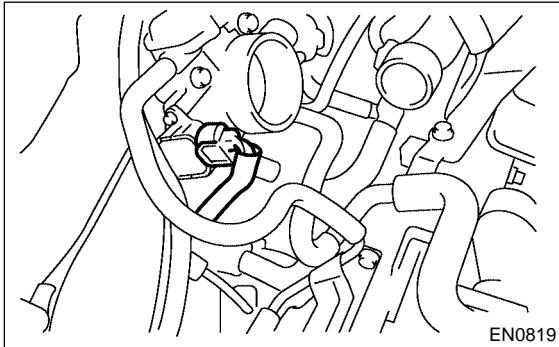

- 4) Remove throttle position sensor holding screws, and remove it.

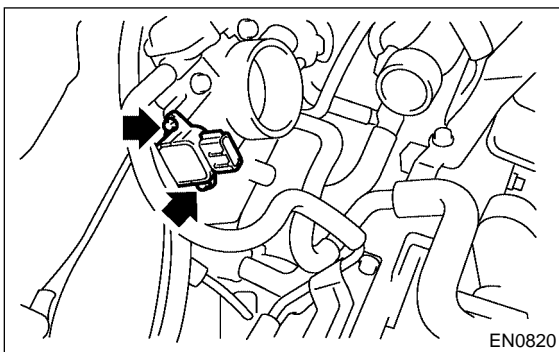

### B: INSTALLATION S185039A11

Install in the reverse order of removal.

**Tightening torque:**

**1.6 N·m (0.16 kgf-m, 1.2 ft-lb)**

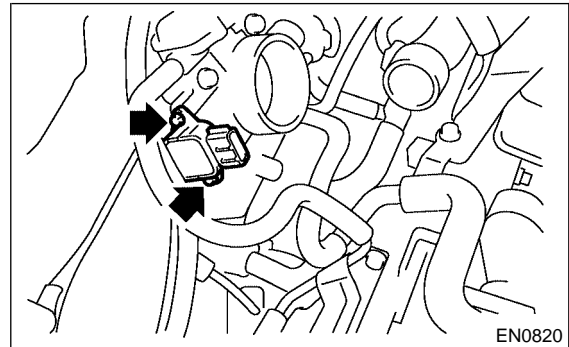

# MASS AIR FLOW AND INTAKE AIR TEMPERATURE SENSOR

Fuel Injection (Fuel Systems)

## 9. Mass Air Flow and Intake Air Temperature Sensor S185770

### A: REMOVAL S185770A18

- 1) Disconnect battery ground cable.

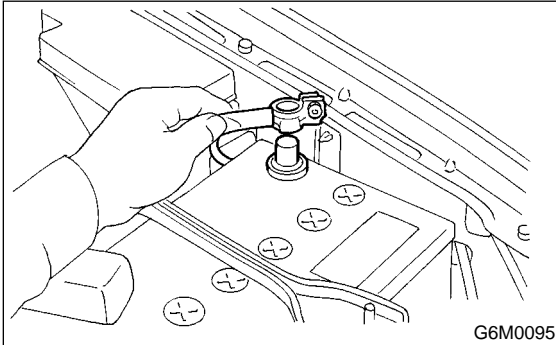

- 2) Disconnect connector mass air flow and intake air temperature sensor.
- 3) Remove mass air flow and intake air temperature sensor.

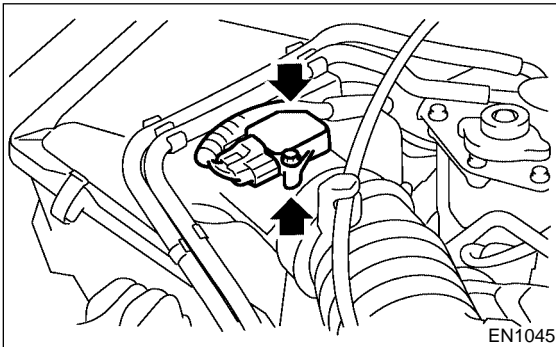

### B: INSTALLATION S185770A11

Install in the reverse order of removal.

**Tightening torque:**

**7.5 N·m (0.76 kgf-m, 5.5 ft-lb)**

## 10. Pressure Sensor S185765

### A: REMOVAL S185765A18

- 1) Disconnect battery ground cable.

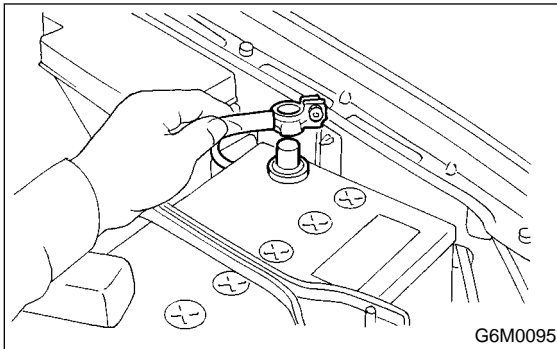

- 2) Remove idle air control solenoid valve. <Ref. to FU(SOHC)-38, REMOVAL, Idle Air Control Solenoid Valve.>
- 3) Disconnect connectors from pressure sensor.

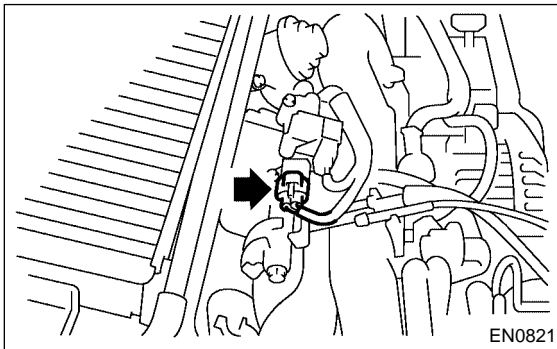

- 4) Remove pressure sensor from throttle body.

### B: INSTALLATION S185765A11

Install in the reverse order of removal.

#### NOTE:

Replace gaskets for idle air control solenoid valve with new ones.

#### **Tightening torque:**

##### **Pressure sensor**

**1.6 N·m (0.16 kgf-m, 1.2 ft-lb)**

##### **Idler air control solenoid valve**

**2.8 N·m (0.29 kgf-m, 2.1 ft-lb)**

# IDLE AIR CONTROL SOLENOID VALVE

Fuel Injection (Fuel Systems)

## 11. Idle Air Control Solenoid Valve

S185056

### A: REMOVAL

S185056A18

- 1) Disconnect battery ground cable.

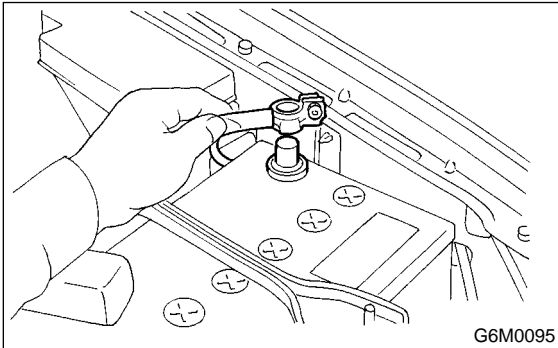

G6M0095

- 2) Disconnect connector from idle air control solenoid valve.

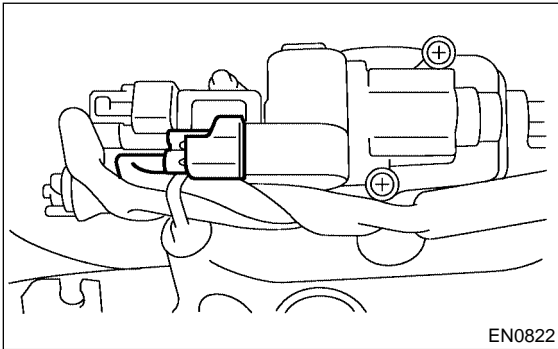

EN0822

- 3) Remove idle air control solenoid valve from throttle body.

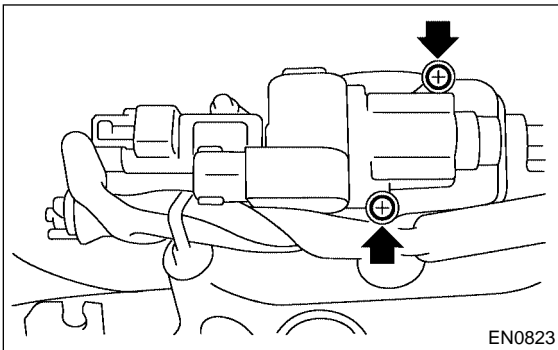

EN0823

### B: INSTALLATION

S185056A11

Install in the reverse order of removal.

NOTE:

Always use new gasket.

**Tightening torque:**

**2.8 N·m (0.29 kgf·m, 2.1 ft·lb)**

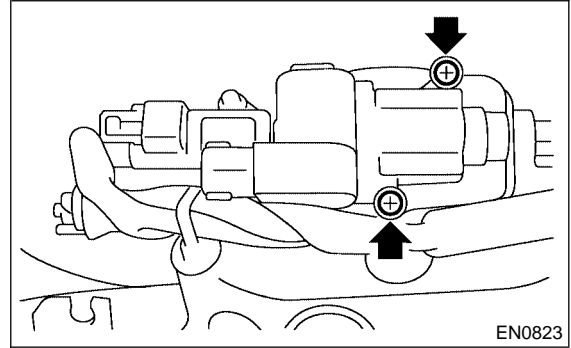

EN0823

## 12. Fuel Injector S185051

### A: REMOVAL S185051A18

#### 1. RH SIDE S185051A1801

- 1) Remove intake manifold. <Ref. to FU(DOHC TURBO)-15, REMOVAL, Intake Manifold.>
- 2) Remove fuel pipe protector.

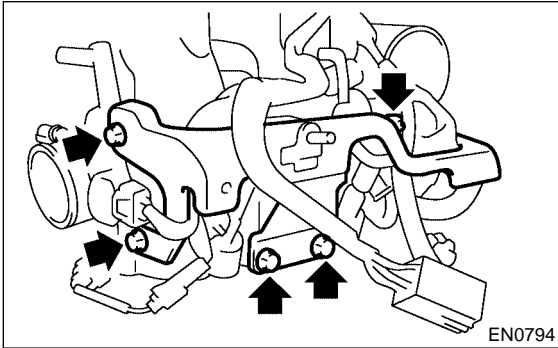

- 3) Disconnect connector from fuel injector.

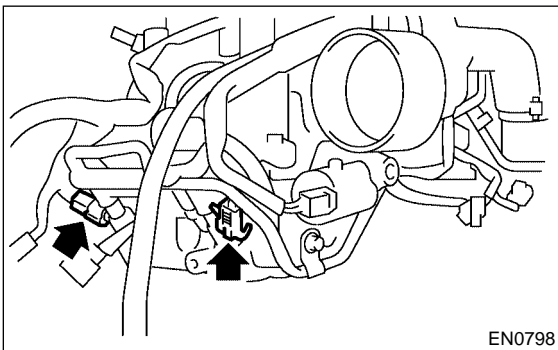

- 4) Remove bolts which hold injector pipe to intake manifold.

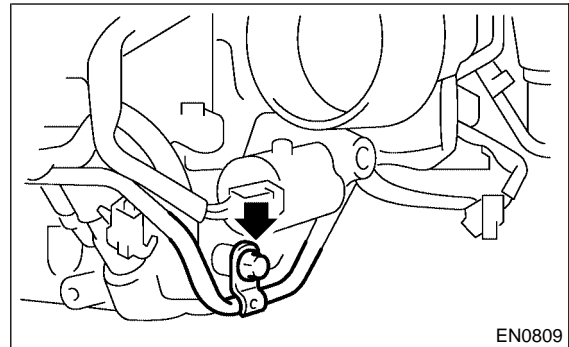
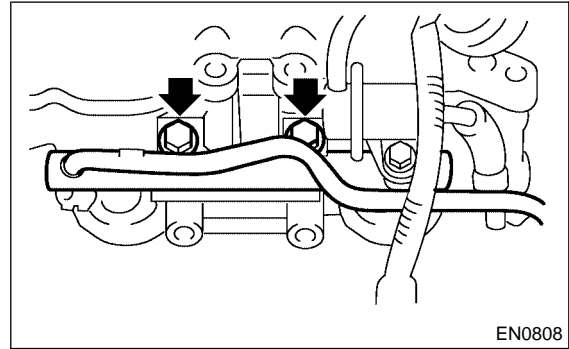

- 5) Remove fuel injector while lifting up fuel injector pipe.

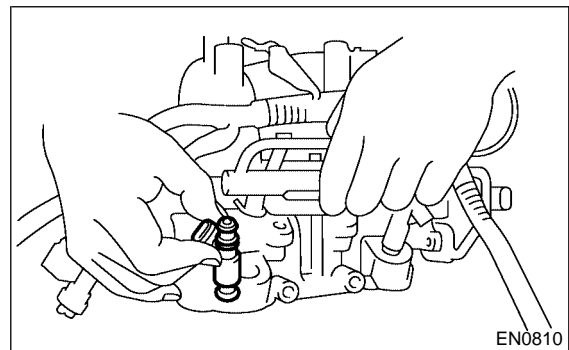

# FUEL INJECTOR

## Fuel Injection (Fuel Systems)

### 2. LH SIDE S185051A1802

- 1) Remove intake manifold. <Ref. to FU(DOHC TURBO)-15, REMOVAL, Intake Manifold.>
- 2) Disconnect connector from fuel injector.

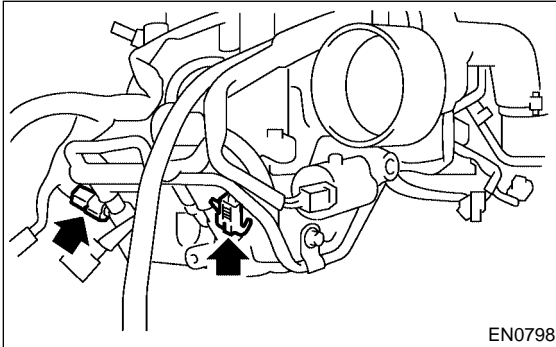

- 3) Remove bolts which hold injector pipe to intake manifold.

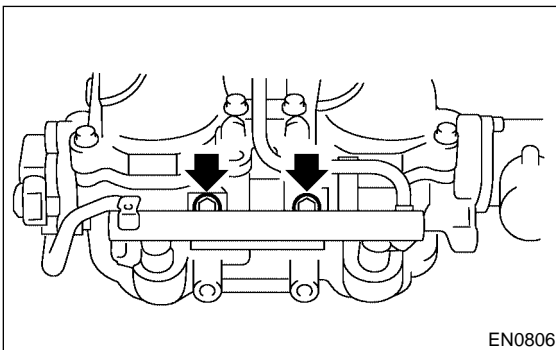
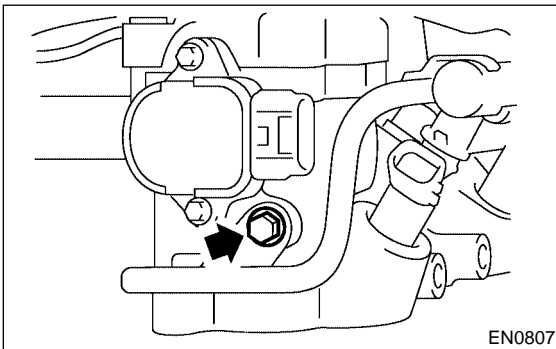
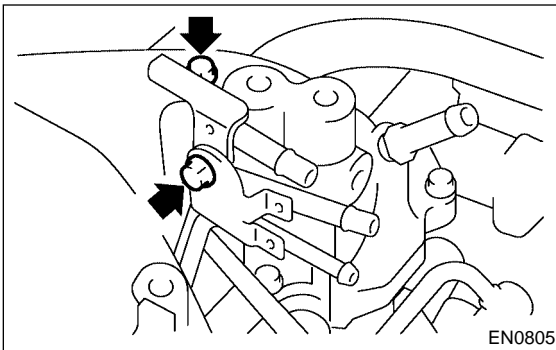

- 4) Remove fuel injector while lifting up fuel injector pipe.

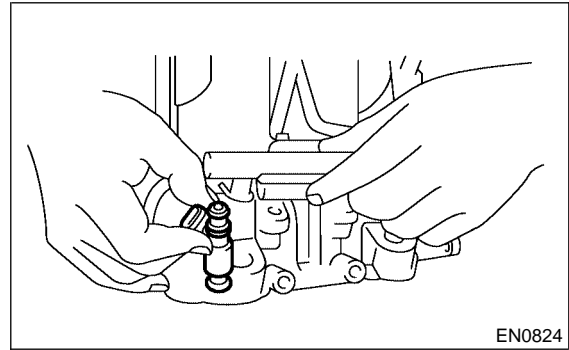

### B: INSTALLATION S185051A11

#### 1. RH SIDE S185051A1101

Install in the reverse order of removal.

#### NOTE:

Replace O-ring and insulators with new ones.

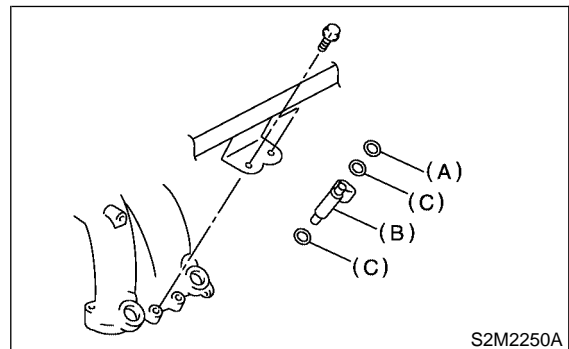

- (A) O-ring
- (B) Fuel injector
- (C) Insulator

#### Tightening torque:

**19 N·m (1.94 kgf·m, 14.0 ft·lb)**

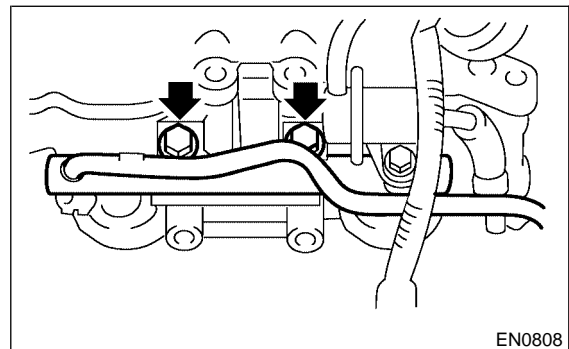

**Tightening torque:**  
**19 N·m (1.94 kgf-m, 14.0 ft-lb)**

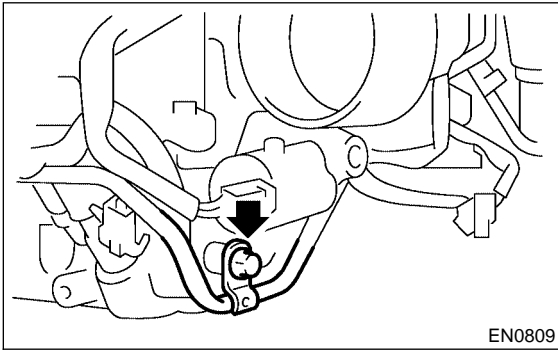

EN0809

**Tightening torque:**  
**5 N·m (0.51 kgf-m, 3.69 ft-lb)**

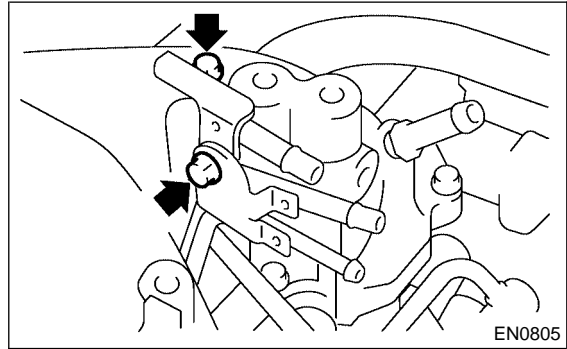

EN0805

**Tightening torque:**  
**19 N·m (1.94 kgf-m, 14.0 ft-lb)**

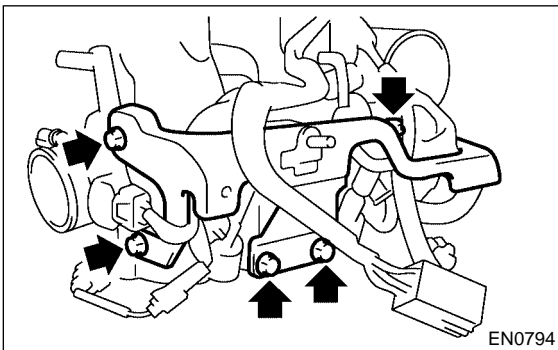

EN0794

**Tightening torque:**  
**19 N·m (1.94 kgf-m, 14.0 ft-lb)**

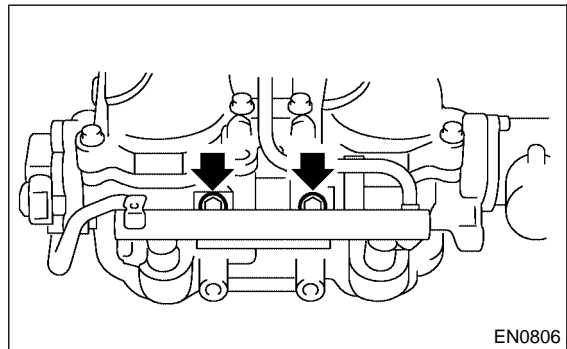

EN0806

## 2. LH SIDE S185051A1102

Install in the reverse order of removal.

**NOTE:**

Replace O-ring and insulators with new ones.

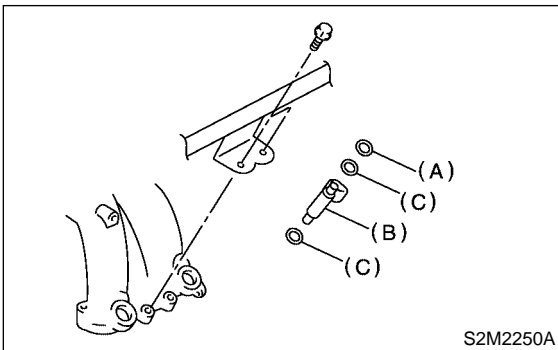

S2M2250A

- (A) O-ring
- (B) Fuel injector
- (C) Insulator

**Tightening torque:**  
**19 N·m (1.94 kgf-m, 14.0 ft-lb)**

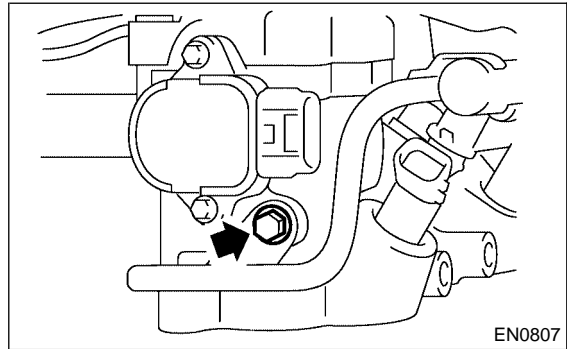

EN0807



# TUMBLE GENERATOR VALVE ASSEMBLY

Fuel Injection (Fuel Systems)

## 13. Tumble Generator Valve Assembly S185766

### A: REMOVAL S185766A18

1) Disconnect battery ground cable.

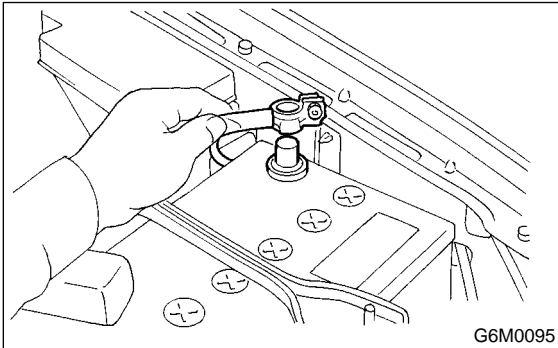

2) Remove intake manifold. <Ref. to FU(DOHC TURBO)-15, REMOVAL, Intake Manifold.>

3) Disconnect connector from tumble generator valve sensor.

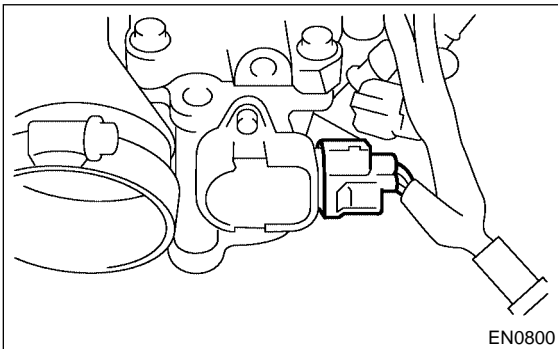

4) Disconnect connector from tumble generator valve actuator.

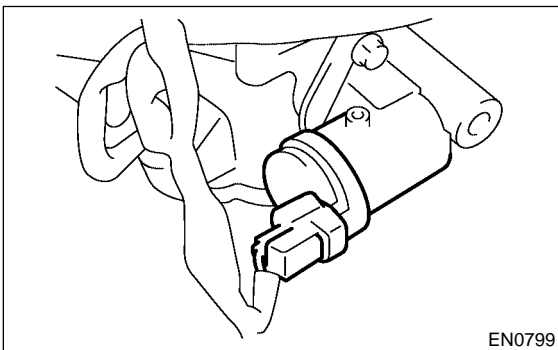

5) Remove fuel injector. <Ref. to FU(DOHC TURBO)-37, REMOVAL, Fuel Injector.>

6) Remove tumble generator valve body from intake manifold.

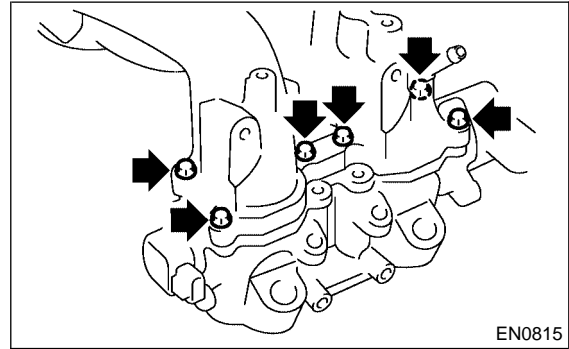

### B: INSTALLATION S185766A11

Install in the reverse order of removal.

NOTE:

Always use new gaskets.

**Tightening torque:**

**8.25 N·m (0.84 kgf-m, 6.1 ft-lb)**

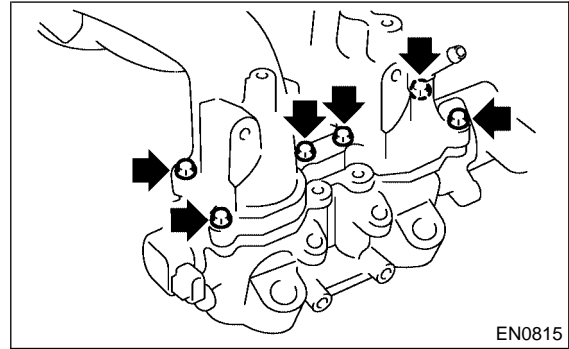

## 14. Wastegate Control Solenoid Valve

S185057

### A: REMOVAL

S185057A18

- 1) Disconnect battery ground cable.

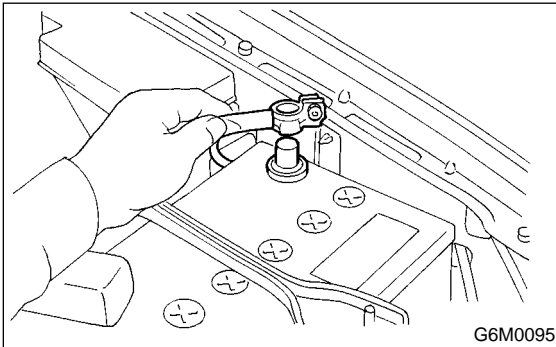

- 2) Disconnect connector (A) from wastegate control solenoid valve.
- 3) Disconnect pressure hoses (B) from wastegate control solenoid valve.
- 4) Remove wastegate control solenoid valve from bracket

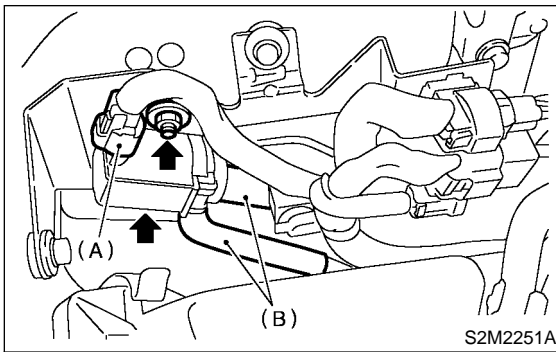

### B: INSTALLATION

S185057A11

Install in the reverse order of removal.

**Tightening torque:**

**6.4 N·m (0.65 kgf-m, 4.7 ft-lb)**

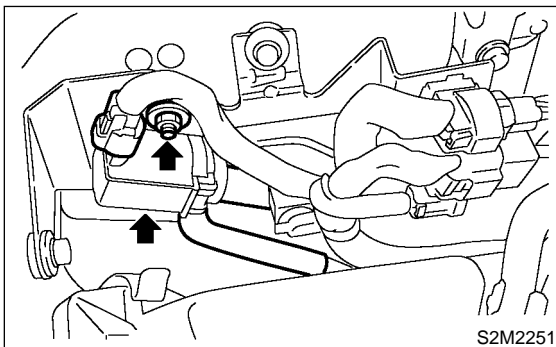

# FRONT OXYGEN (A/F) SENSOR

Fuel Injection (Fuel Systems)

## 15. Front Oxygen (A/F) Sensor

S185642

### A: REMOVAL S185642A18

- 1) Disconnect battery ground cable.

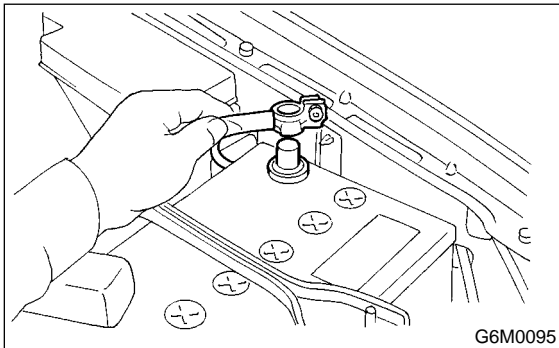

- 2) Disconnect connector from front oxygen (A/F) sensor.

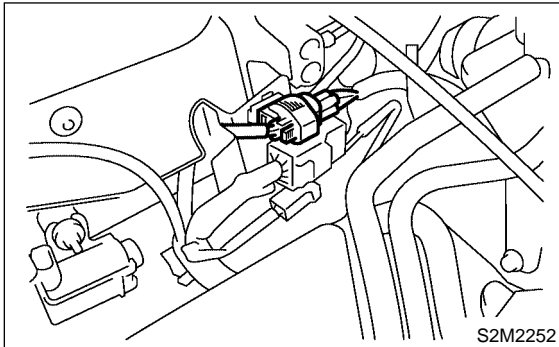

- 3) Remove harness secured by clip (A) from the bracket (B).

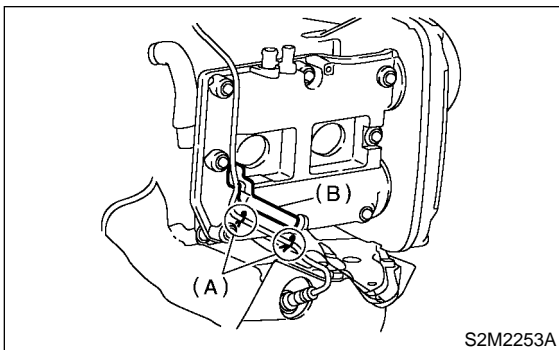

- 4) Remove front right side wheel.
- 5) Lift-up the vehicle.

- 6) Remove service hole cover.

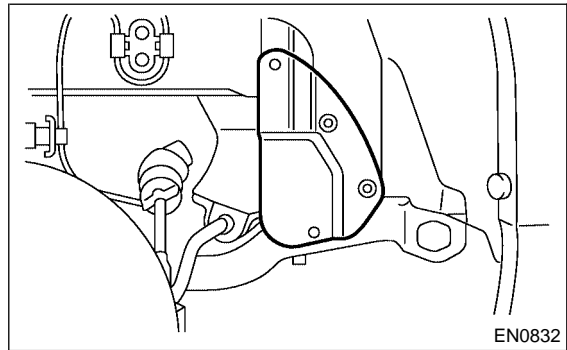

- 7) Apply SUBARU CRC or its equivalent to threaded portion of front oxygen (A/F) sensor, and leave it for one minute or more.

**SUBARU CRC (Part No. 004301003)**

- 8) Remove front oxygen (A/F) sensor.

**CAUTION:**  
When removing the oxygen (A/F) sensor, wait until exhaust pipe cools, otherwise it will damage exhaust pipe.

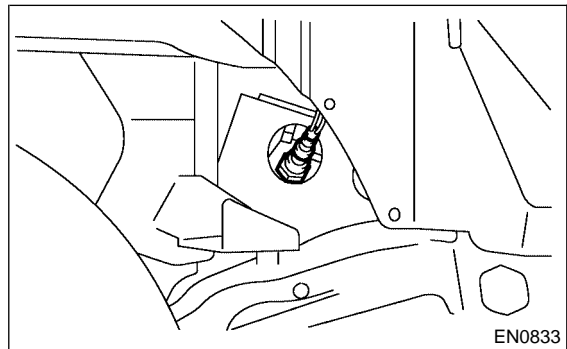

## B: INSTALLATION S185642A11

1) Before installing front oxygen (A/F) sensor, apply anti-seize compound only to threaded portion of front oxygen (A/F) sensor to make the next removal easier.

**Anti-seize compound:**  
**SS-30 by JET LUBE**

**CAUTION:**  
**Never apply anti-seize compound to protector of front oxygen (A/F) sensor.**

2) Install front oxygen (A/F) sensor.

**Tightening torque:**  
**30N·m (3.1 kgf·m, 22 ft·lb)**

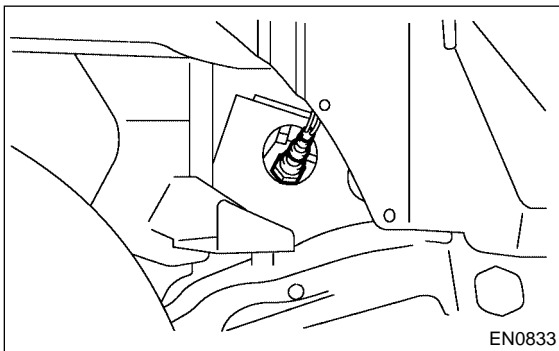

3) Install service hole cover.

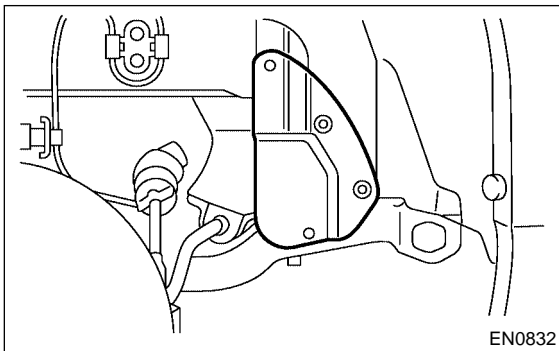

4) Lower the vehicle.

5) Install front right side wheel.

6) Secure a harness to bracket (B) by clip (A).

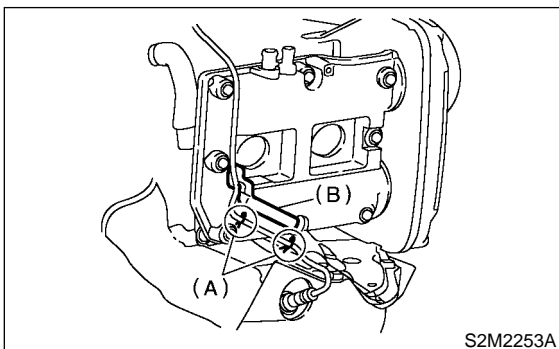

7) Connect connector of front oxygen (A/F) sensor.

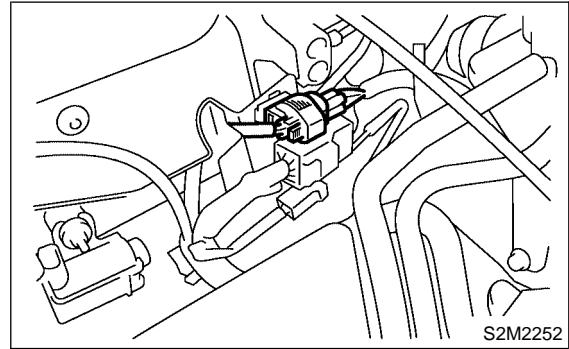

8) Connect battery ground cable.

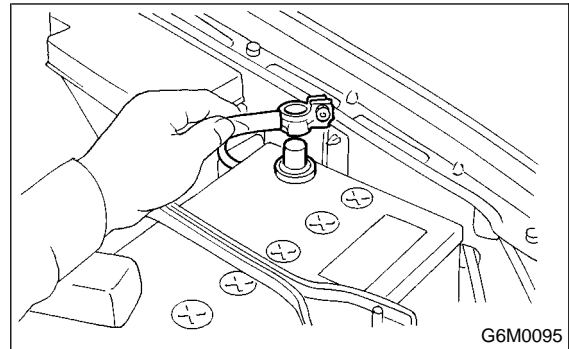

# REAR OXYGEN SENSOR

Fuel Injection (Fuel Systems)

## 16. Rear Oxygen Sensor S185657

### A: REMOVAL S185657A18

- 1) Disconnect battery ground cable.

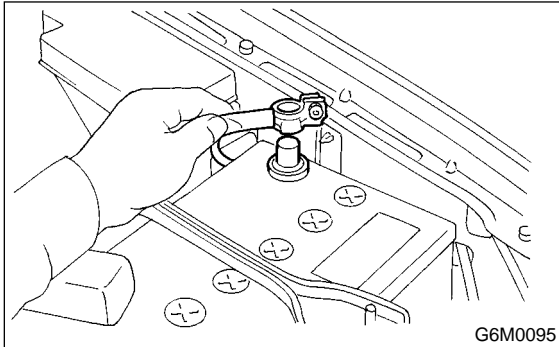

- 2) Lift-up the vehicle.
- 3) Disconnect connector from rear oxygen sensor.

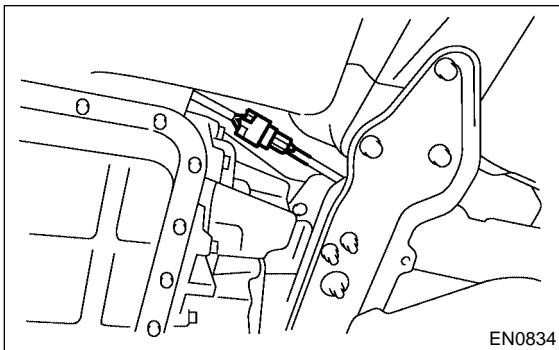

- 4) Vertically draw out clip (A) from crossmember (B).

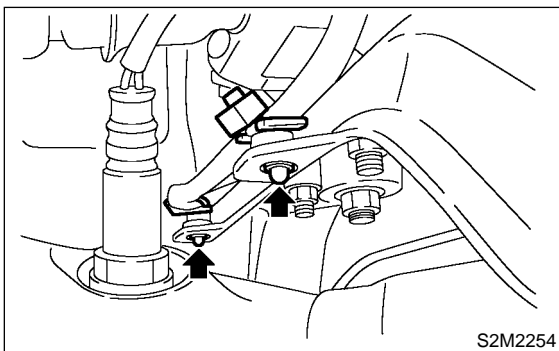

- 5) Apply SUBARU CRC or its equivalent to threaded portion of rear oxygen sensor, and leave it for one minute or more.

***SUBARU CRC (Part No. 004301003)***

- 6) Remove rear oxygen sensor.

### CAUTION:

When removing the oxygen sensor, wait until exhaust pipe cools, otherwise it will damage exhaust pipe.

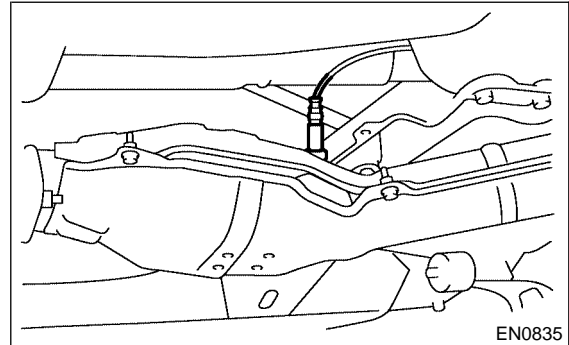

## B: INSTALLATION S185657A11

1) Before installing rear oxygen sensor, apply anti-seize compound only to threaded portion of rear oxygen sensor to make the next removal easier.

### CAUTION:

**Never apply anti-seize compound to protector of rear oxygen sensor.**

**Anti-seize compound:**  
**SS-30 by JET LUBE**

2) Install rear oxygen sensor.

**Tightening torque:**  
**21 N·m (2.1 kgf-m, 15.2 ft-lb)**

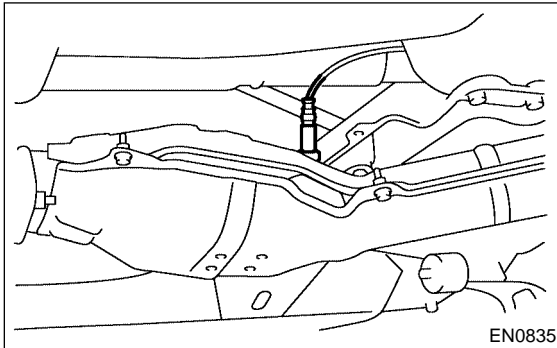

3) Connect connector to rear oxygen sensor.

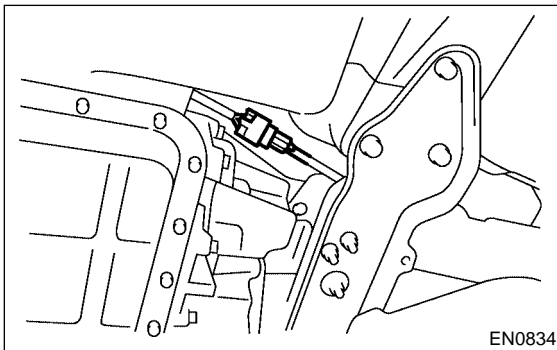

4) Secure clip (A) on the crossmember.

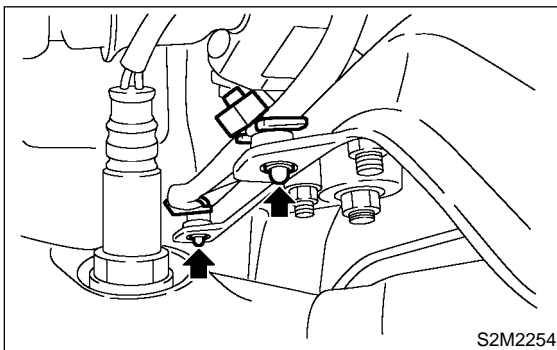

5) Lower the vehicle.

6) Connect battery ground cable.

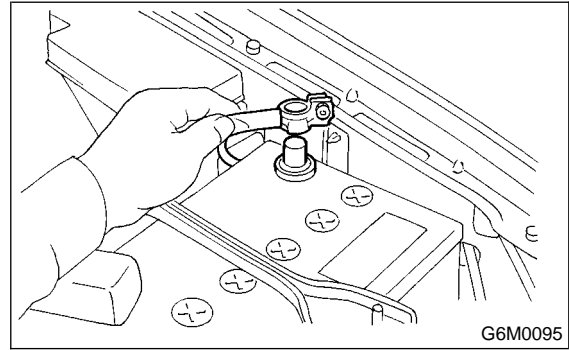

# EXHAUST TEMPERATURE SENSOR

Fuel Injection (Fuel Systems)

## 17. Exhaust Temperature Sensor

S185763

### A: REMOVAL

S185763A18

- 1) Disconnect battery ground cable.

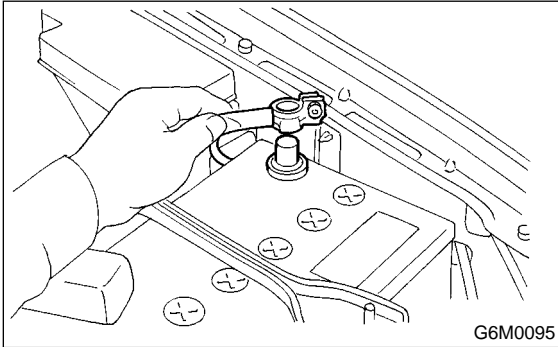

- 2) Remove joint pipe. <Ref. to EX(DOHC TURBO)-13, REMOVAL, Joint Pipe.>

- 3) Apply SUBARU CRC or its equivalent to threaded portion of exhaust temperature sensor, and leave it for one minute or more.

**SUBARU CRC (Part No. 004301003)**

- 4) Remove exhaust temperature sensor.

#### CAUTION:

When removing the oxygen sensor, wait until exhaust pipe cools, otherwise it will damage exhaust pipe.

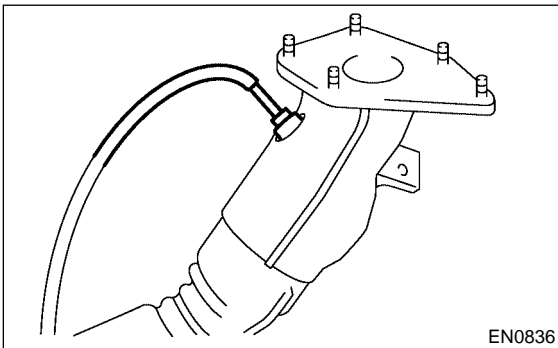

### B: INSTALLATION

S185763A11

- 1) Before installing exhaust temperature sensor, apply anti-seize compound only to threaded portion of rear oxygen sensor to make the next removal easier.

#### CAUTION:

Never apply anti-seize compound to protector of exhaust temperature sensor.

#### Anti-seize compound:

**SS-30 by JET LUBE**

- 2) Install exhaust temperature sensor.

#### NOTE:

Align mark (A) on the exhaust temperature sensor side with the joint pipe side mark (B) and tighten.

#### Tightening torque:

**21 N·m (2.1 kgf-m, 15.2 ft-lb)**

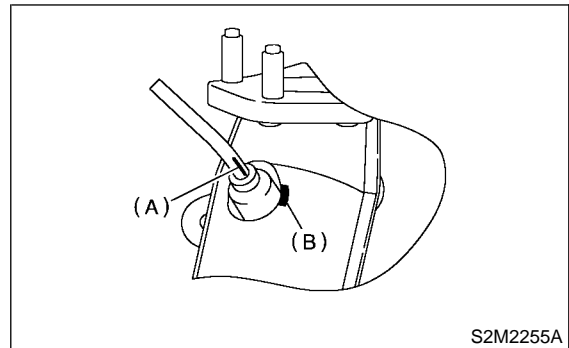

- 3) Install joint pipe <Ref. to EX(DOHC TURBO)-13, INSTALLATION, Joint Pipe.>
- 4) Connect battery ground cable.

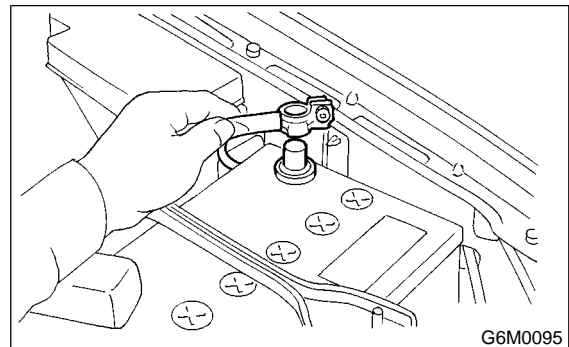

## 18. Engine Control Module S185049

### A: REMOVAL S185049A18

- 1) Disconnect battery ground cable.

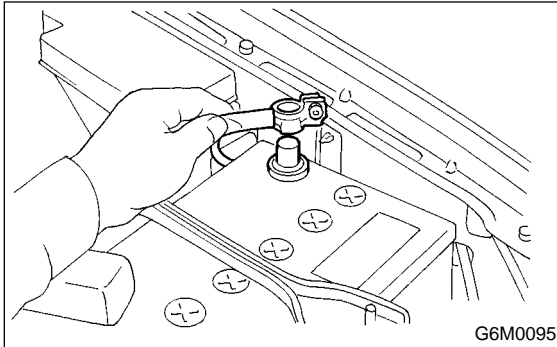

- 2) Remove lower inner trim of passenger side.  
<Ref. to EI-38, REMOVAL, Lower Inner Trim.>
- 3) Detach floor mat of front passenger seat.
- 4) Remove protect cover.

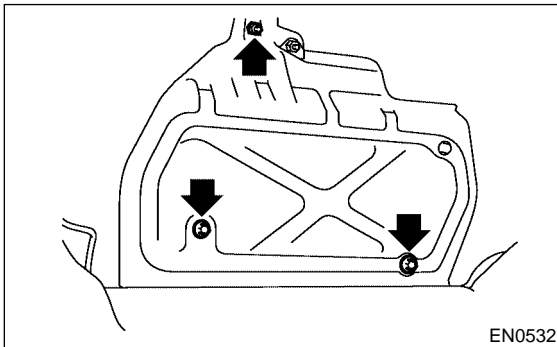

- 5) Remove nuts (A) which hold ECM to bracket.
- 6) Remove clip (B) from bracket.

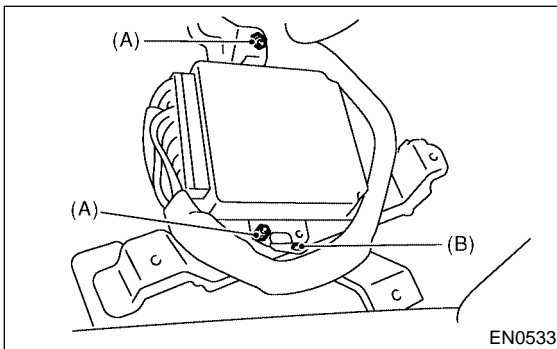

- 7) Disconnect ECM connectors and take out ECM.

### B: INSTALLATION S185049A11

Install in the reverse order of removal.

#### CAUTION:

When replacing ECM, be careful not to use the wrong spec. ECM to avoid any damage to the fuel injection system.



# MAIN RELAY

Fuel Injection (Fuel Systems)

## 19. Main Relay S185050

### A: REMOVAL S185050A18

1) Disconnect battery ground cable.

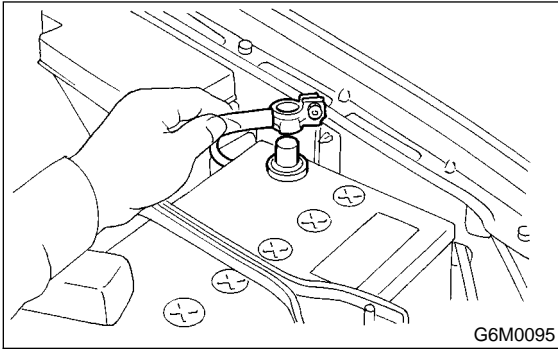

2) Remove bolt which holds bracket of main relay and fuel pump relay.

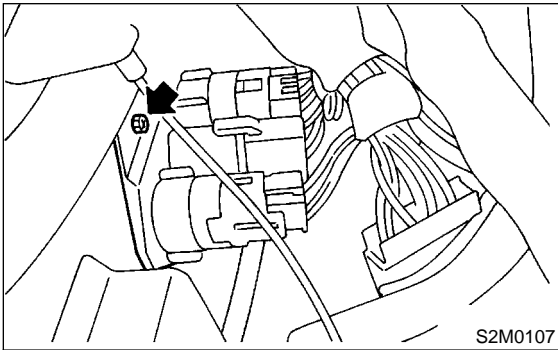

3) Disconnect connectors from relays.

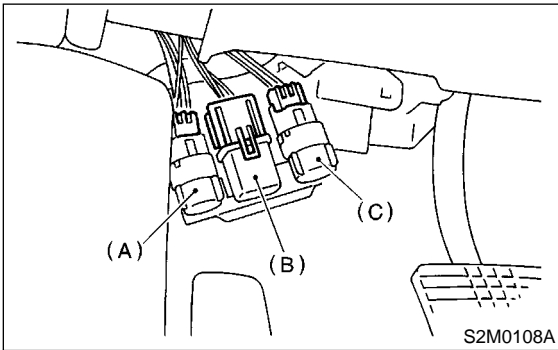

- (A) Blower fan motor relay
- (B) Main relay
- (C) Fuel pump relay

4) Remove main relay from mounting bracket.

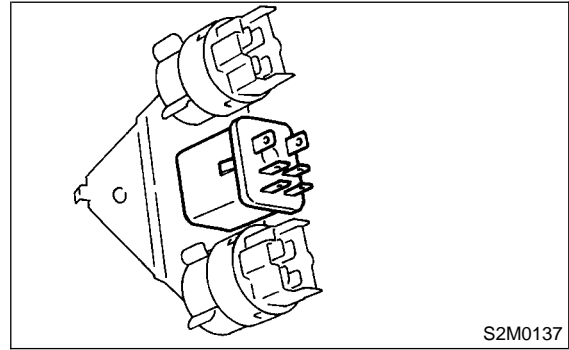

### B: INSTALLATION S185050A11

Install in the reverse order of removal.

## 20. Fuel Pump Relay S185048

### A: REMOVAL S185048A18

- 1) Disconnect battery ground cable.

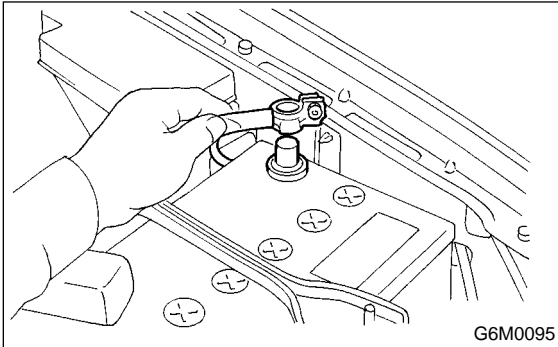

- 2) Disconnect connector from fuel pump relay.

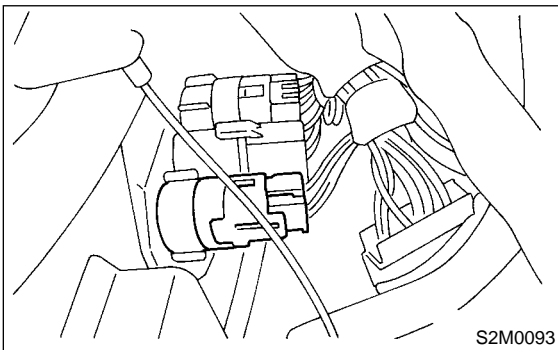

- 3) Remove fuel pump relay from mounting bracket.

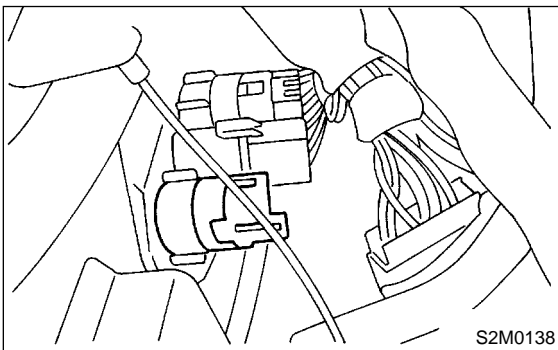

### B: INSTALLATION S185048A11

Install in the reverse order of removal.

## 21. Fuel S185052

### A: OPERATION S185052A16

#### 1. RELEASING OF FUEL PRESSURE

S185052A1601

##### WARNING:

- Place “NO FIRE” signs near the working area.

- Disconnect ground terminal from battery.

1) Disconnect connector from fuel pump relay.

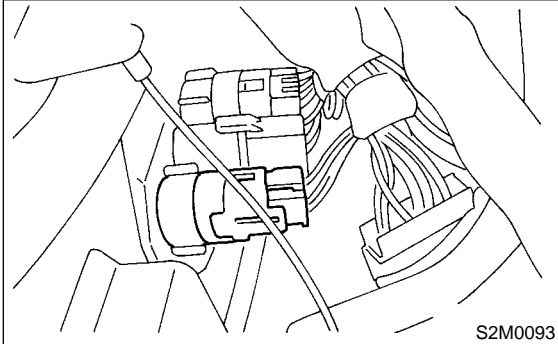

2) Start the engine, and run it until it stalls.

3) After the engine stalls, crank it for five more seconds.

4) Turn ignition switch to OFF.

#### 2. DRAINING OF FUEL S185052A1603

##### WARNING:

- Place “NO FIRE” signs near the working area.

- Be careful not to spill fuel on the floor.

1) Release fuel pressure. <Ref. to FU(DOHC TURBO)-50, RELEASING OF FUEL PRESSURE, OPERATION, Fuel.>

2) Open fuel flap lid, and remove fuel filler cap.

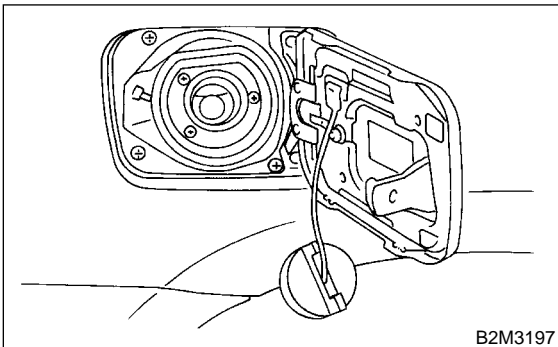

3) Disconnect battery ground cable.

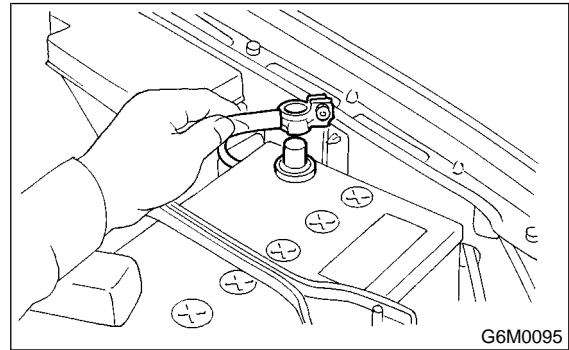

4) Remove the floor box located just behind the rear seats.

5) Remove access hole lid.

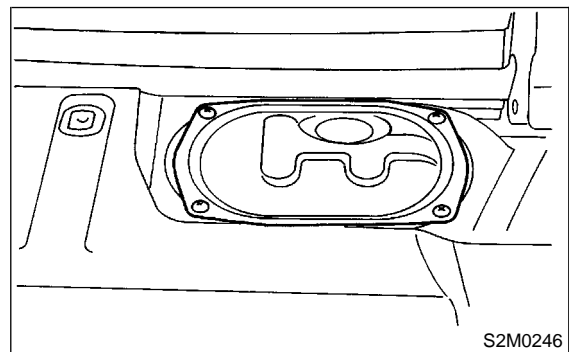

6) Disconnect connector from fuel pump.

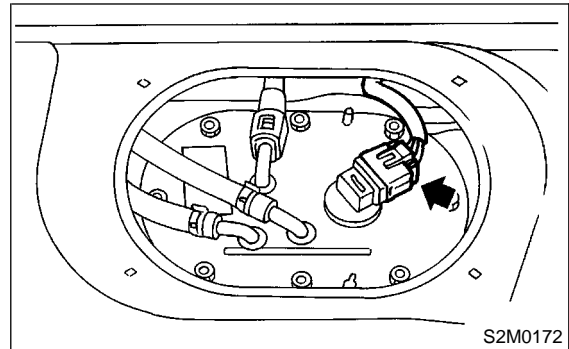

7) Disconnect quick connector, and then disconnect fuel delivery hose (A). <Ref. to FU(DOHC TURBO)-67, REMOVAL, Fuel Delivery, Return and Evaporation Lines.>

8) Move clips, and then disconnect fuel return hose (B) and jet pump hose (C).

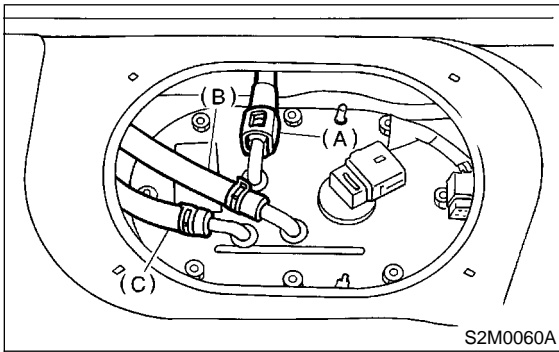

9) Remove nuts which install fuel pump assembly onto fuel tank.

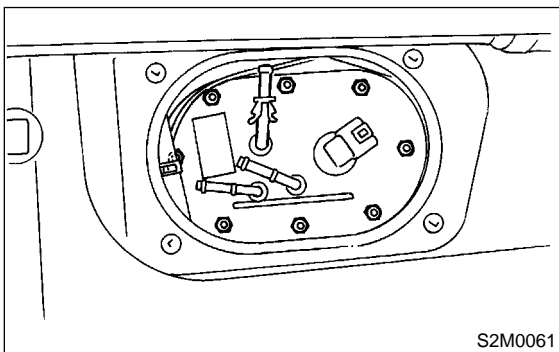

10) Take off fuel pump from fuel tank.

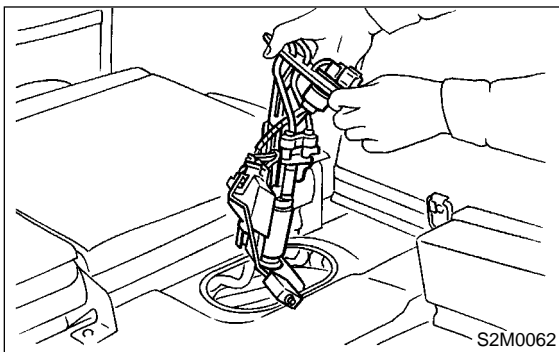

11) Drain fuel from fuel tank by using a hand pump.

**WARNING:**  
Do not use a motor pump when draining fuel.

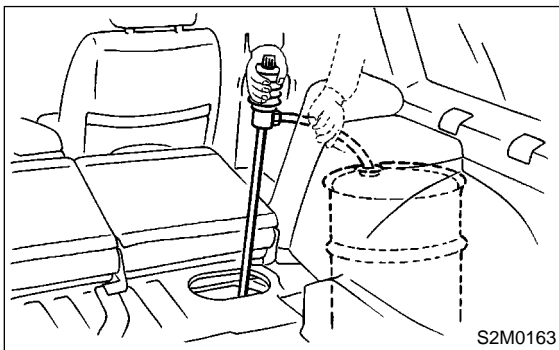

12) Remove service hole cover.

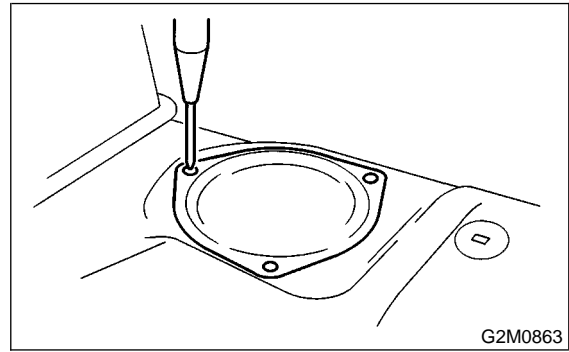

13) Disconnect connector from fuel sub level sensor.

14) Disconnect fuel jet pump hose.

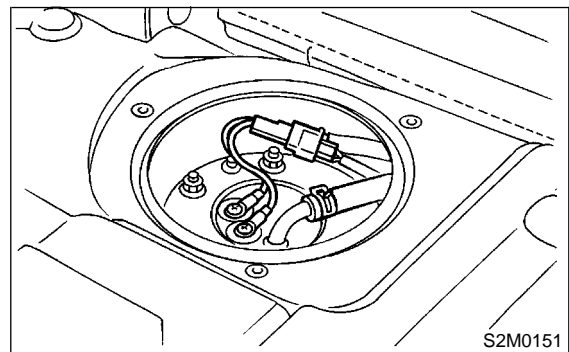

15) Remove bolts which install fuel sub level sensor on fuel tank.

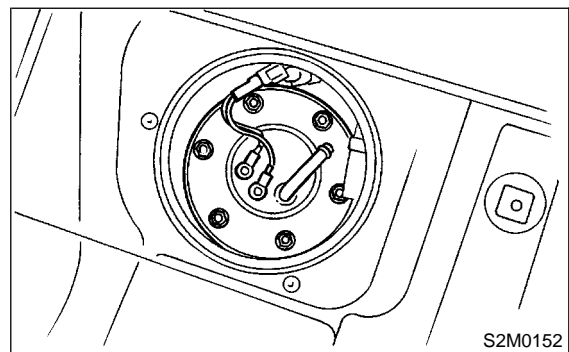

16) Remove fuel sub level sensor.

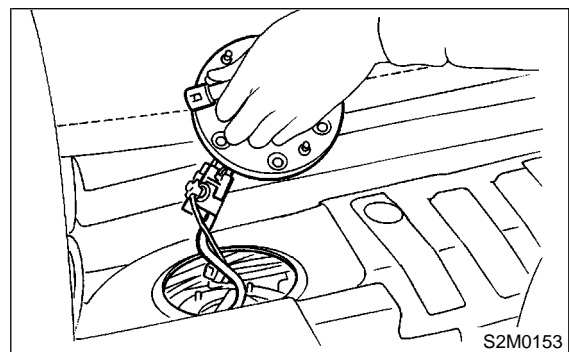

# FUEL

Fuel Injection (Fuel Systems)

---

17) Drain fuel from there.

**WARNING:**

**Do not use a motor pump when draining fuel.**

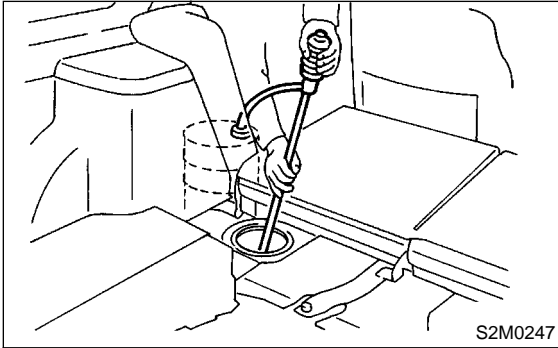

## 22. Fuel Tank S185053

### A: REMOVAL S185053A18

**WARNING:**

- Place “NO FIRE” signs near the working area.
- Be careful not to spill fuel on the floor.

- 1) Set vehicle on the lift.
- 2) Release fuel pressure. <Ref. to FU(DOHC TURBO)-52, RELEASING OF FUEL PRESSURE, OPERATION, Fuel.>
- 3) Drain fuel from fuel tank. <Ref. to FU(DOHC TURBO)-50, DRAINING FUEL, OPERATION, Fuel.>
- 4) Remove rear seat.
- 5) Disconnect connector of fuel tank cord to rear harness.

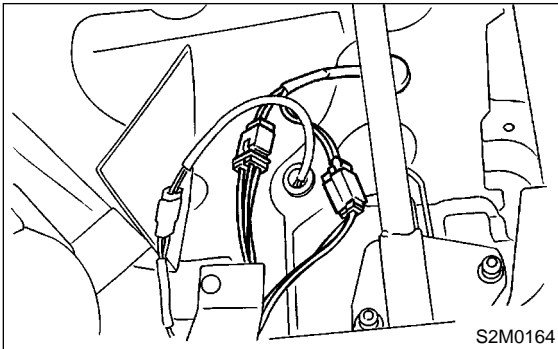

- 6) Push grommet which holds fuel tank cord on floor panel into under the body.

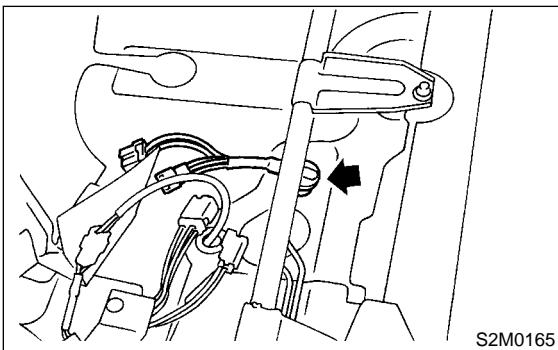

- 7) Remove rear crossmember. <Ref. to RS-20, REMOVAL, Rear Crossmember.>

- 8) Disconnect two-way valve hose (A) from two-way valve and disconnect canister hose (B) from canister.

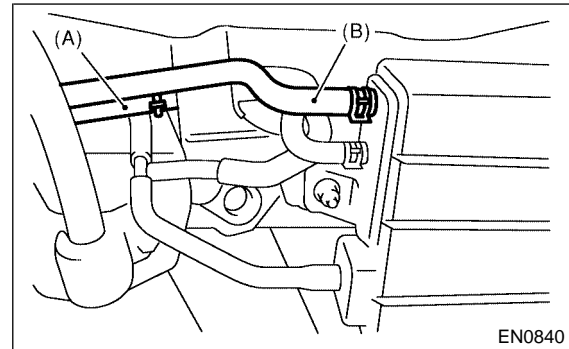

- 9) Loosen clamp and disconnect fuel filler hose (A) and air vent hose (B) from fuel filler pipe.

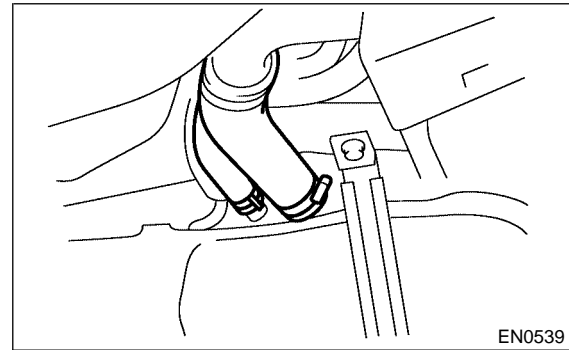

- 10) Move clips, and disconnect quick connector. <Ref. to FU(DOHC TURBO)-67, REMOVAL, Fuel Delivery, Return and Evaporation Lines.>
- 11) Disconnect fuel hoses.

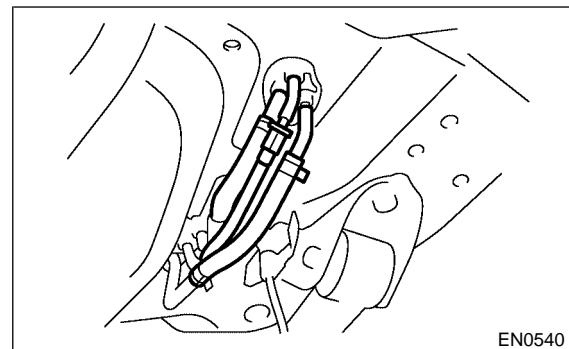

# FUEL TANK

## Fuel Injection (Fuel Systems)

12) Support fuel tank with transmission jack, remove bolts from bands and dismount fuel tank from the vehicle.

### WARNING:

A helper is required to perform this work.

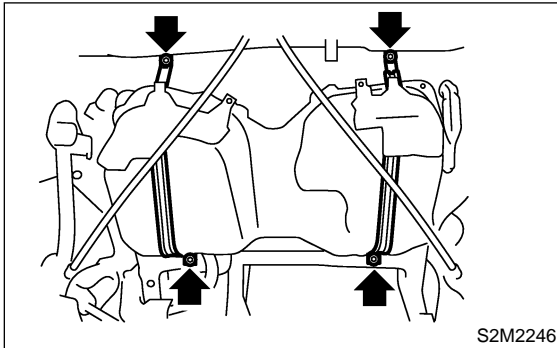

## B: INSTALLATION

S185053A11

1) Support fuel tank with transmission jack and push fuel tank harness into access hole with grommet.

2) Set fuel tank and temporarily tighten bolts of fuel tank bands.

### WARNING:

A helper is required to perform this work.

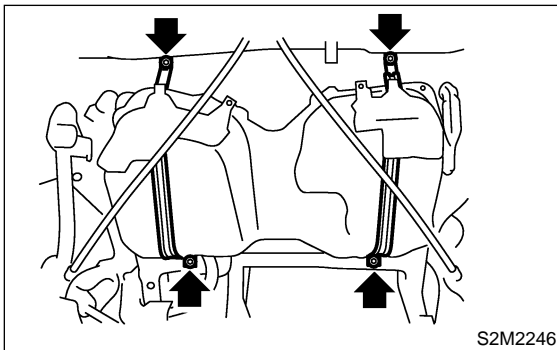

3) Connect two-way valve hose (A) to two-way valve and connect canister hose (B) to canister.

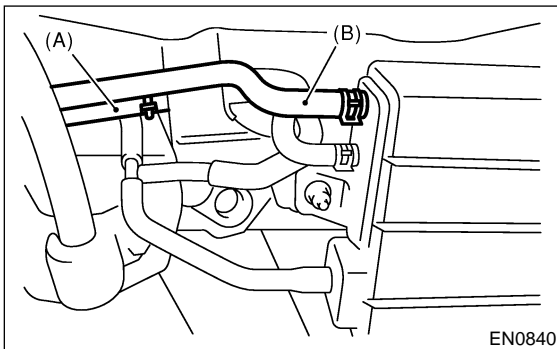

4) Connect fuel filler hose (A) and air vent hose (B).

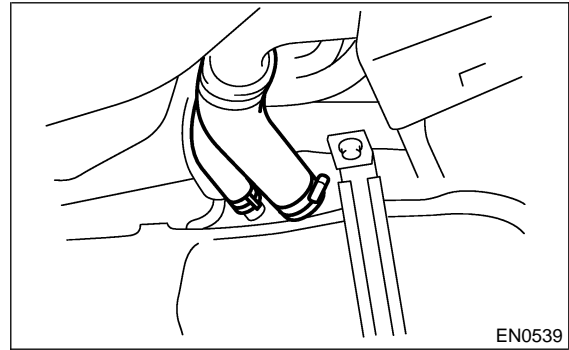

5) Connect fuel hoses, and hold then with clips and quick connector. <Ref. to FU(DOHC TURBO)-68, INSTALLATION, Fuel Delivery, Return and Evaporation Lines.>

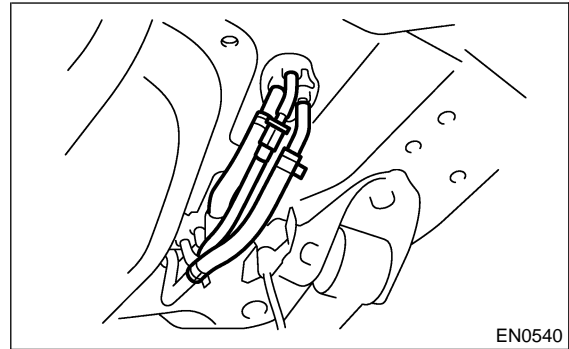

6) Tighten band mounting bolts.

**Tightening torque:**

**33 N·m (3.4 kgf·m, 25 ft·lb)**

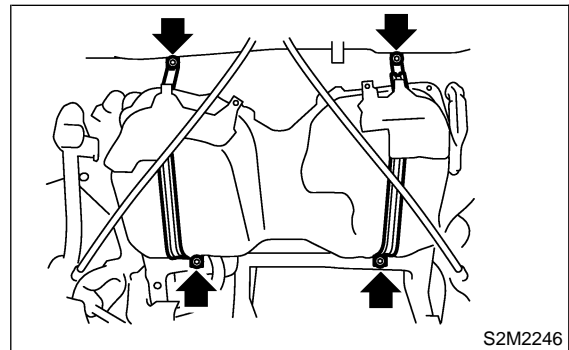

7) Install rear crossmember. <Ref. to RS-20, INSTALLATION, Rear Crossmember.>

- 8) Connect connectors to fuel tank cord and plug service hole with grommet.

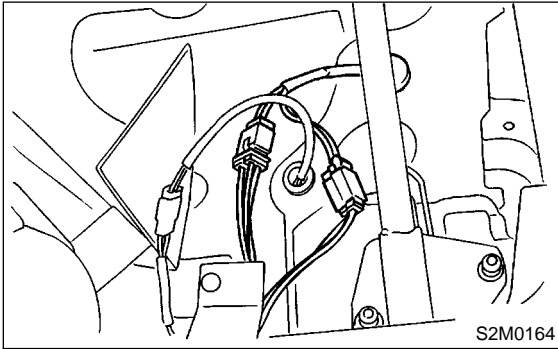

- 9) Set rear seat and floor mat.
- 10) Connect connector to fuel pump relay.

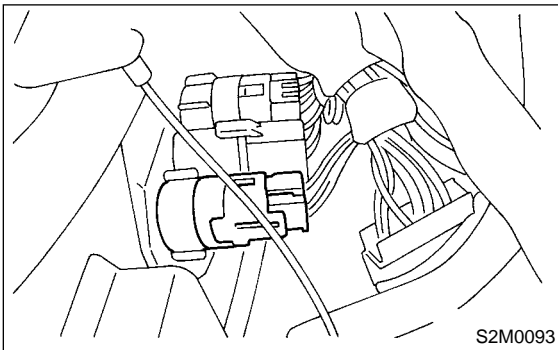

## C: INSPECTION S185053A10

- 1) Make sure there are no cracks, holes, or other damage on the fuel tank.
- 2) Make sure that the fuel hoses and fuel pipes are not cracked and that connections are tight.



# FUEL FILLER PIPE

Fuel Injection (Fuel Systems)

## 23. Fuel Filler Pipe S185022

### A: REMOVAL S185022A18

#### WARNING:

- Place "NO FIRE" signs near the working area.
- Be careful not to spill fuel on the floor.

- 1) Release fuel pressure. <Ref. to FU(DOHC TURBO)-50, RELEASING OF FUEL PRESSURE, OPERATION, Fuel.>
- 2) Open fuel filler flap lid and remove filler cap.
- 3) Disconnect battery ground cable.

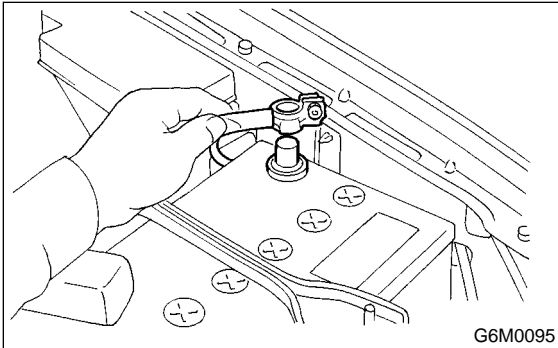

- 4) Remove screws holding packing in place.

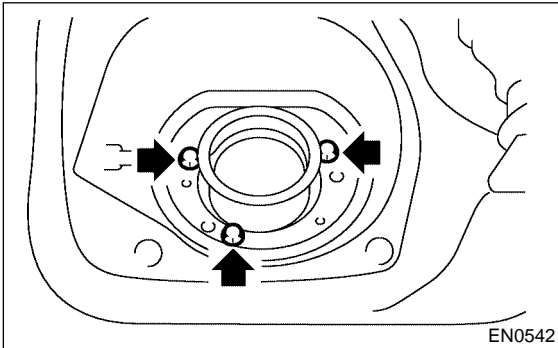

- 5) Lift-up the vehicle.
- 6) Remove rear right side wheel nuts.
- 7) Remove rear right side wheel.

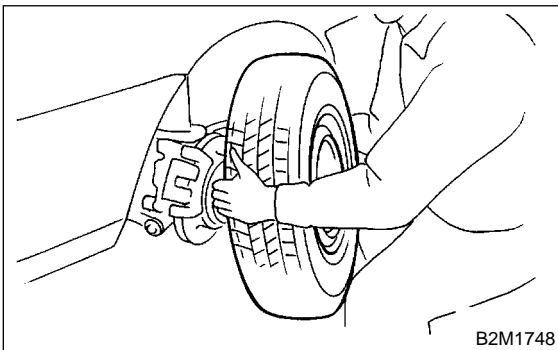

- 8) Remove fuel filler pipe protector.

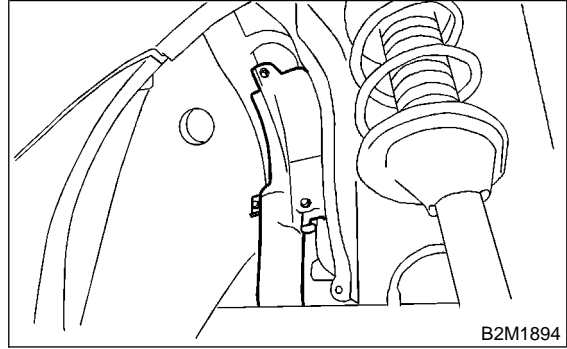

- 9) Separate evaporation hoses from clip of fuel filler pipe.

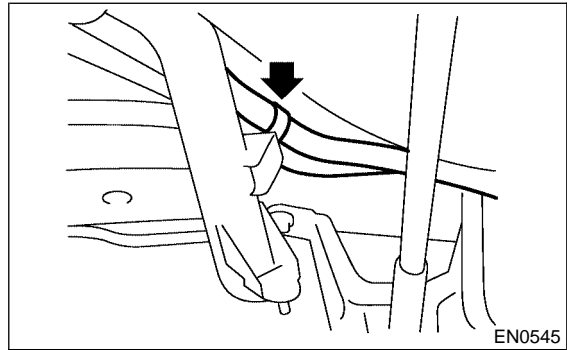

- 10) Disconnect air vent hose from fuel filler pipe.

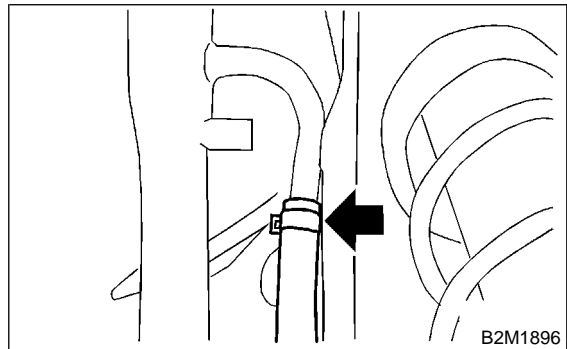

- 11) Remove bolts which hold fuel filler pipe bracket on body.

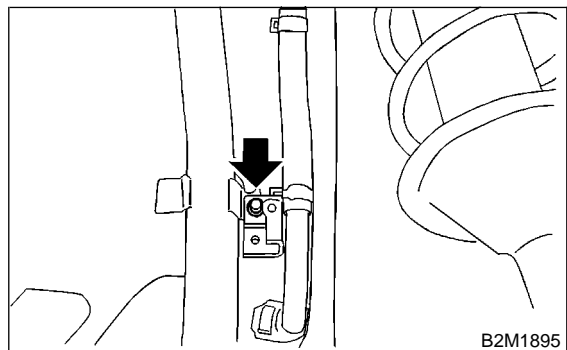

# FUEL FILLER PIPE

Fuel Injection (Fuel Systems)

- 12) Loosen clamp and separate fuel filler hose (A) from fuel filler pipe.
- 13) Move clip and separate air vent hose (B).

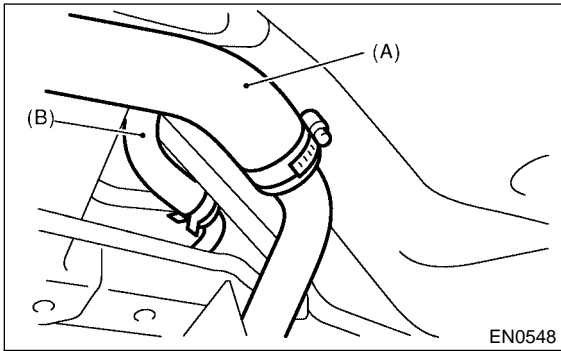

- 14) Remove fuel filler pipe to under side of the vehicle.
- 15) Remove air vent pipe together with clip from body.

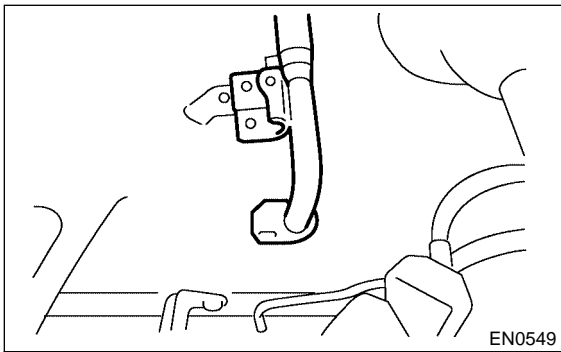

## B: INSTALLATION

S185022A11

- 1) Hold fuel filler flap open.
- 2) Set fuel saucer (A) with rubber packing (C) and insert fuel filler pipe into hole from the inner side of apron.

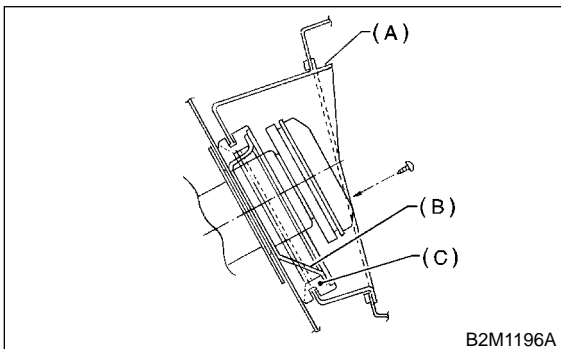

- 3) Align holes in fuel filler pipe neck and set cup (B), and tighten screws.

### NOTE:

If edges of rubber packing are folded toward the inside, straighten it with a screwdriver.

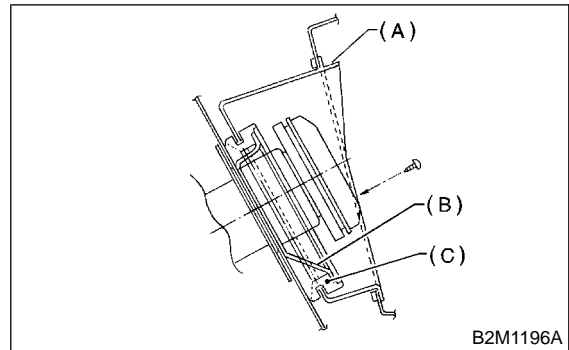

- 4) Install air vent pipe.

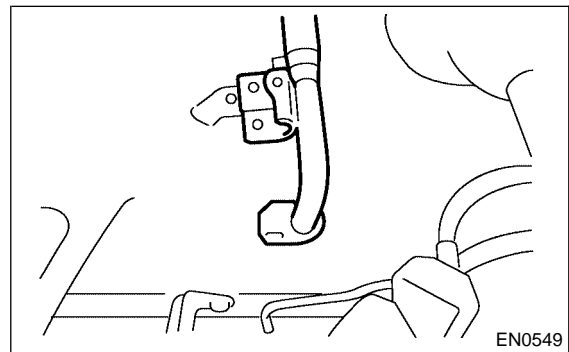

- 5) Connect air vent hose to fuel filler pipe.

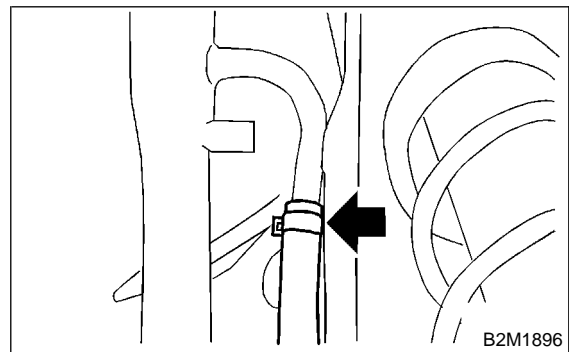

# FUEL FILLER PIPE

## Fuel Injection (Fuel Systems)

6) Insert fuel filler hose (A) approximately 35 to 40 mm (1.38 to 1.57 in) over the lower end of fuel filler pipe and tighten clamp.

### CAUTION:

Do not allow clips to touch air vent hose (B) and rear suspension crossmember.

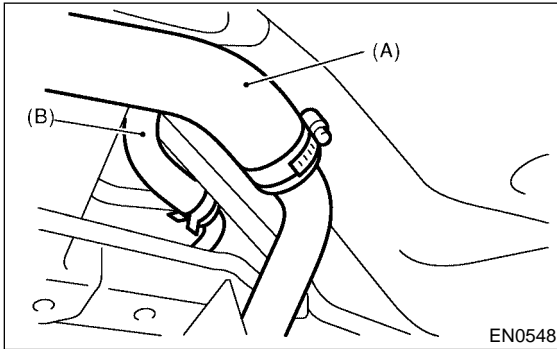

7) Insert air vent hose approximately 25 to 30 mm (0.98 to 1.18 in) into the lower end of air vent pipe and hold clip.

$L = 27.5 \pm 2.5 \text{ mm (1.083} \pm 0.098 \text{ in)}$

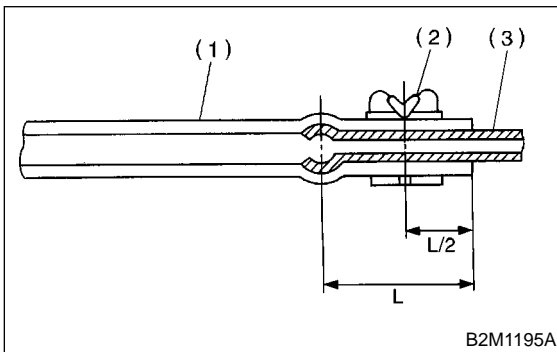

- (1) Hose
- (2) Clip
- (3) Pipe

8) Tighten bolt which holds fuel filler pipe bracket on body.

### Tightening torque:

$7.5 \text{ N}\cdot\text{m (0.75 kgf}\cdot\text{m, 5.4 ft}\cdot\text{lb)}$

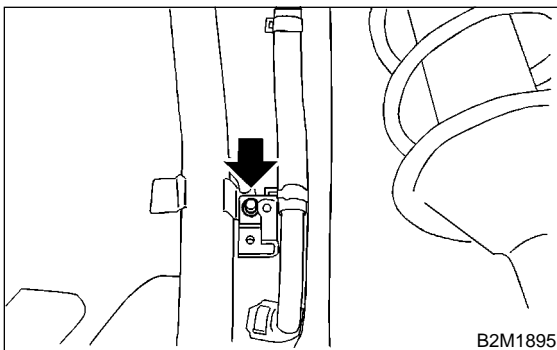

9) Tighten bolts which hold evaporation hoses onto clip of fuel filler pipe.

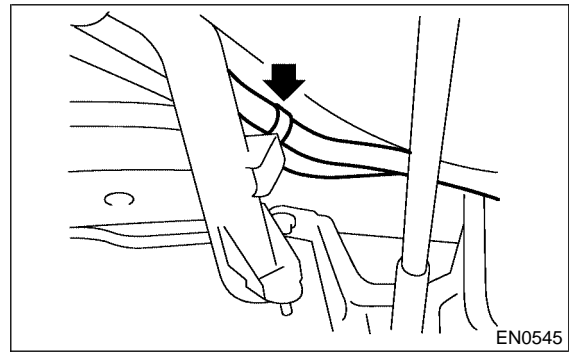

10) Install fuel filler pipe protector.

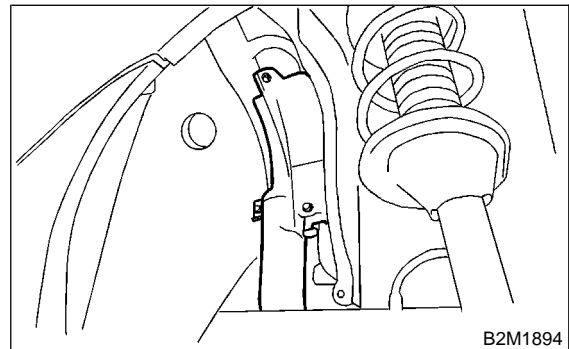

11) Install rear right wheel.

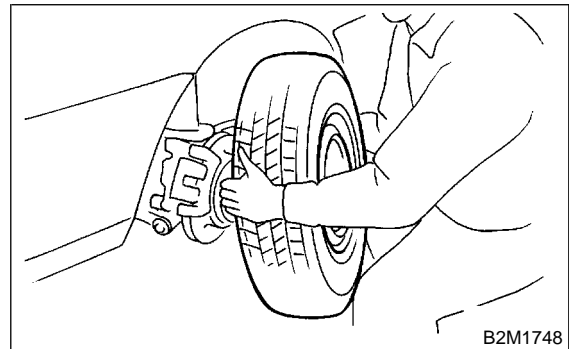

12) Lower the vehicle.

13) Tighten wheel nuts.

14) Connect connector to fuel pump relay.

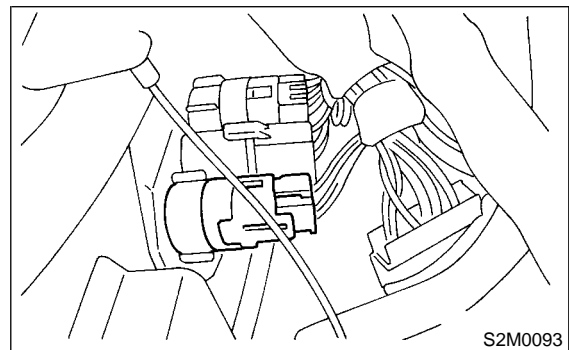

15) Connect battery ground terminal.

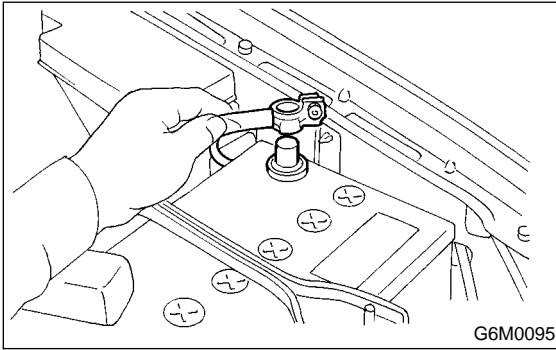

# FUEL PUMP

Fuel Injection (Fuel Systems)

## 24. Fuel Pump S185025

### A: REMOVAL S185025A18

#### WARNING:

- Place "No fire" signs near the working area.
- Be careful not to spill fuel on the floor.

- 1) Release fuel pressure. <Ref. to FU(DOHC TURBO)-50, RELEASING OF FUEL PRESSURE, OPERATION, Fuel.>
- 2) Open fuel filler flap lid, and remove fuel filler cap.

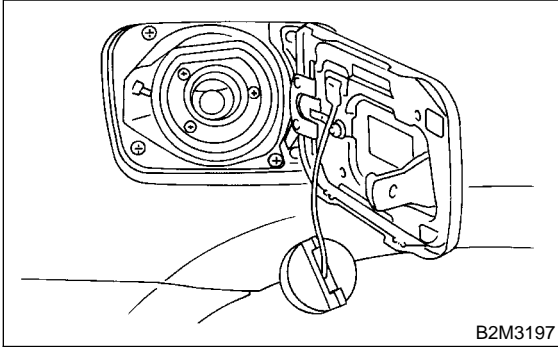

- 3) Disconnect battery ground cable.

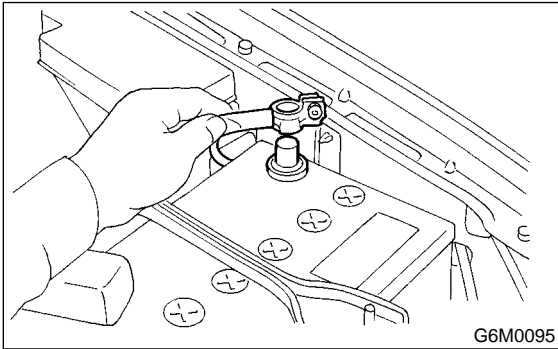

- 4) Remove the floor box located just behind the rear seats.
- 5) Remove access hole lid.

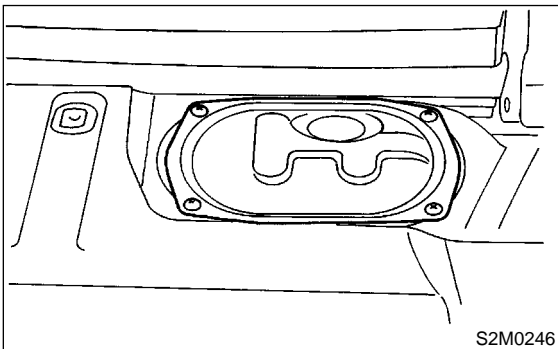

- 6) Disconnect connector from fuel pump.

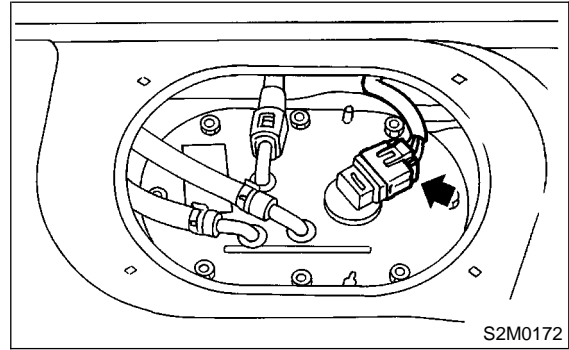

- 7) Move clips, and then disconnect fuel delivery hose (A), return hose (B) and jet pump hose (C).
- 8) Disconnect quick connector, and then disconnect fuel delivery hose (A). <Ref. to FU(DOHC TURBO)-67, REMOVAL, Fuel Delivery, Return and Evaporation Lines.>

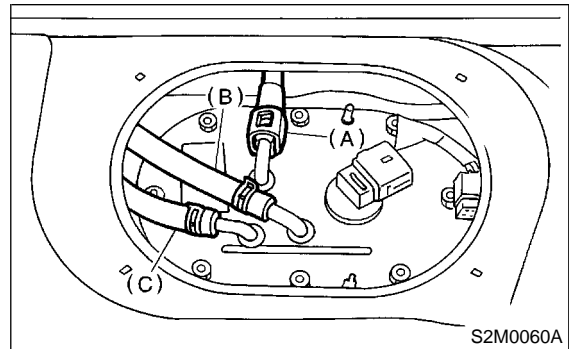

- 9) Remove nuts which install fuel pump assembly onto fuel tank.

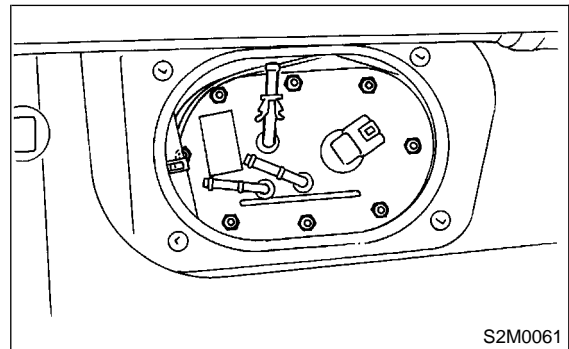

- 10) Take off fuel pump from fuel tank.

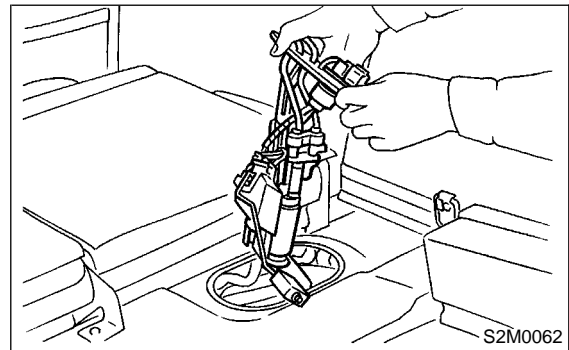

FU(DOHC TURBO)-60

## B: INSTALLATION S185025A11

Install in the reverse order of removal. Do the following:

- (1) Always use new gaskets.
- (2) Ensure sealing portion is free from fuel or foreign particles before installation.
- (3) Tighten nuts in alphabetical sequence shown in the figure to specified torque.

### **Tightening torque:**

**4.4 N·m (0.45 kgf·m, 3.3 ft·lb)**

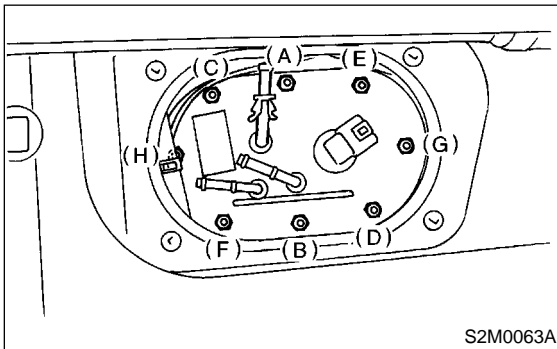

## C: INSPECTION S185025A10

Connect lead harness to connector terminal of fuel pump, and apply battery power supply to check whether the pump operate.

### **WARNING:**

- Wipe off the fuel completely.
- Keep battery as far apart from fuel pump as possible.
- Be sure to turn the battery supply ON and OFF on the battery side.
- Do not run fuel pump for a long time under non-load condition.

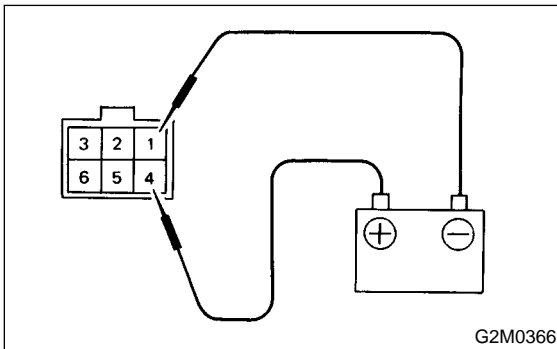

# FUEL LEVEL SENSOR

Fuel Injection (Fuel Systems)

## 25. Fuel Level Sensor S185026

### A: REMOVAL S185026A18

#### WARNING:

- Place “NO FIRE” signs near the working area.
- Be careful not to spill fuel on the floor.

#### NOTE:

Fuel level sensor is built in fuel pump assembly.

- 1) Remove fuel pump assembly. <Ref. to FU(DOHC TURBO)-60, REMOVAL , Fuel Pump.>
- 2) Disconnect connector from fuel pump bracket.

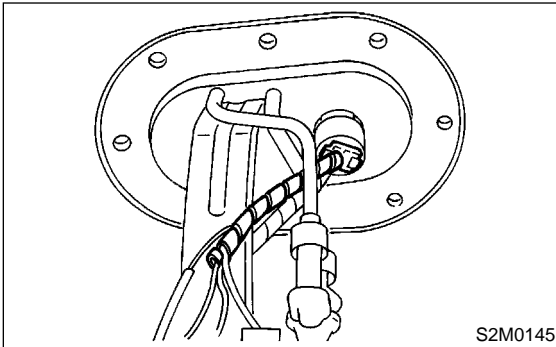

- 3) Remove bolt which installs fuel level sensor on mounting bracket.

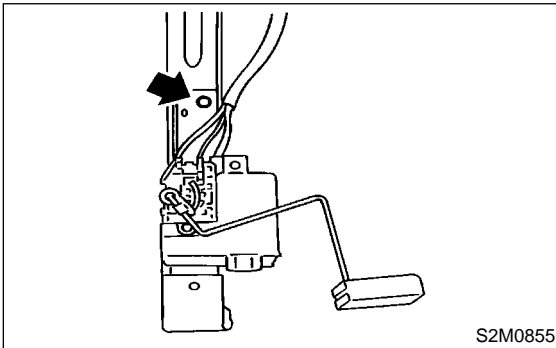

### B: INSTALLATION S185026A11

Install in the reverse order of removal.

## 26. Fuel Sub Level Sensor S185023

### A: REMOVAL S185023A18

**WARNING:**

- Place “NO FIRE” signs near the working area.
- Be careful not to spill fuel on the floor.

- 1) Disconnect battery ground cable.

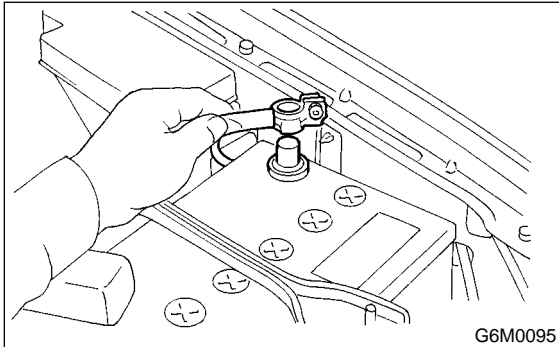

- 2) Remove the floor box located just behind the rear seats.
- 3) Remove service hole cover.

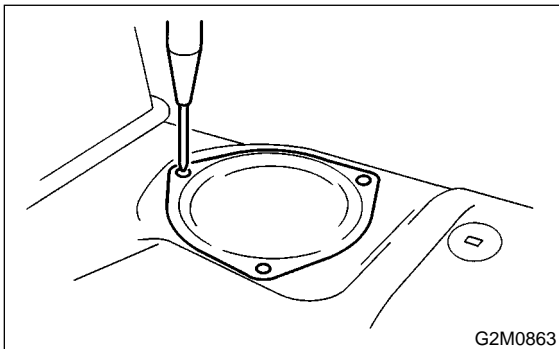

- 4) Disconnect connector from fuel sub level sensor.
- 5) Disconnect fuel jet pump hose.

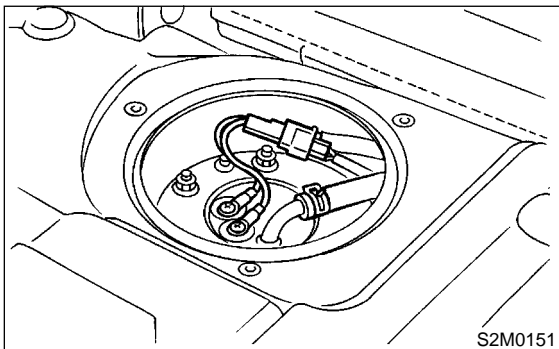

- 6) Remove bolts which install fuel sub level sensor on fuel tank.

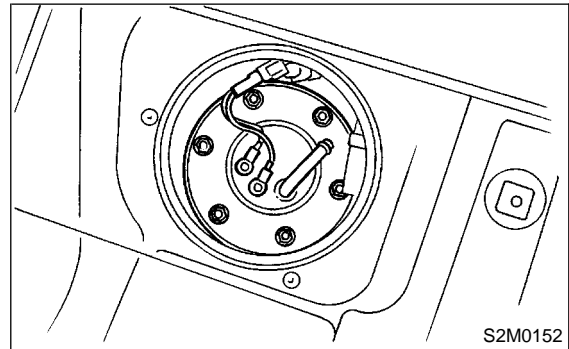

- 7) Remove fuel sub level sensor.

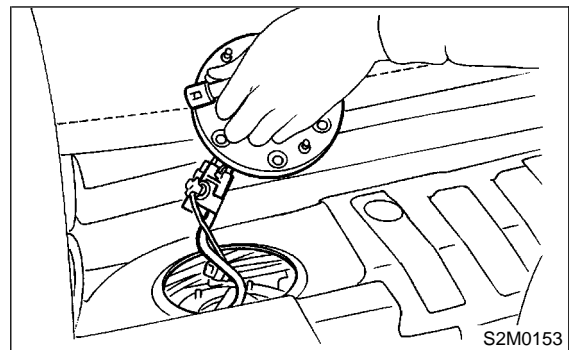

### B: INSTALLATION S185023A11

Install in the reverse order of removal.

**Tightening torque:**

**4.4 N·m (0.45 kgf-m, 3.3 ft-lb)**

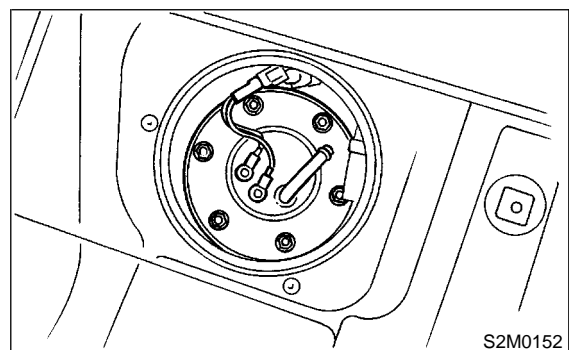



## 27. Fuel Filter S185027

### A: REMOVAL S185027A18

#### WARNING:

- Place “NO FIRE” signs near the working area.
- Be careful not to spill fuel on the floor.

- 1) Release fuel pressure. <Ref. to FU(DOHC TURBO)-50, RELEASING OF FUEL PRESSURE, OPERATION, Fuel.>
- 2) Disconnect fuel delivery hoses from fuel filter.

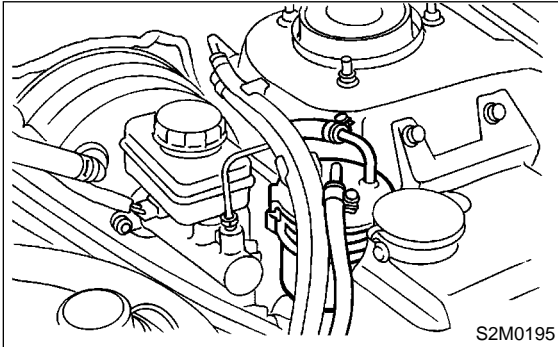

- 3) Remove filter from holder.

### B: INSTALLATION S185027A11

#### CAUTION:

- If fuel hoses are damaged at the connecting portion, replace it with a new one.
- If clamps are badly damaged, replace with new ones.

- 1) Install in the reverse order of removal.
- 2) Tighten hose clamp screws.

#### **Tightening torque:**

**12.5 N·m (1.27 kgf-m, 9.22 ft-lb)**

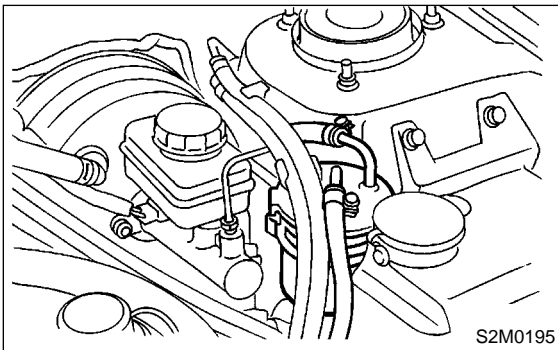

### C: INSPECTION S185027A10

- 1) Check the inside of fuel filter for dirt and water sediment.
- 2) If it is clogged, or if replacement interval has been reached, replace it.
- 3) If water is found in it, shake and expel the water from inlet port.

## 28. Fuel Cut Valve S185021

### A: REMOVAL S185021A18

**WARNING:**

- Place “NO FIRE” signs near the working area.

- Be careful not to spill fuel on the floor.

1) Remove fuel tank. <Ref. to FU(DOHC TURBO)-53, REMOVAL, Fuel Tank.>

2) Move clip and disconnect evaporation hose from fuel cut valve.

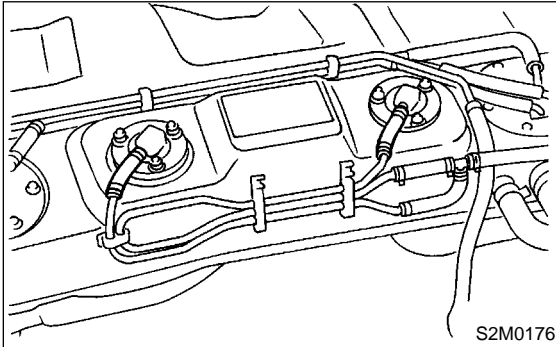

3) Remove bolts which install fuel cut valve.

### B: INSTALLATION S185021A11

Install in the reverse order of removal.

**Tightening torque:**

**4.4 N·m (0.45 kgf·m, 3.3 ft·lb)**

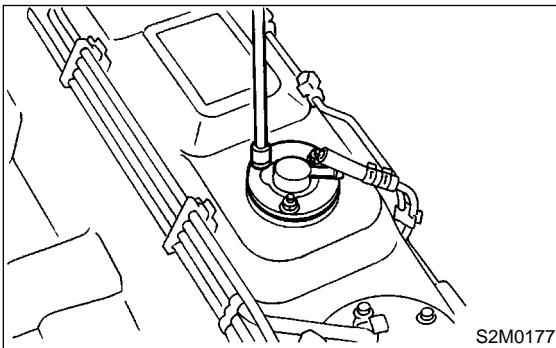

# FUEL DAMPER VALVE

Fuel Injection (Fuel Systems)

---

## 29. Fuel Damper Valve S185708

### A: REMOVAL S185708A18

- 1) Release fuel pressure. <Ref. to FU(DOHC TURBO)-50, RELEASING OF FUEL PRESSURE, OPERATION, Fuel.>
- 2) Remove fuel damper valve from fuel return line.

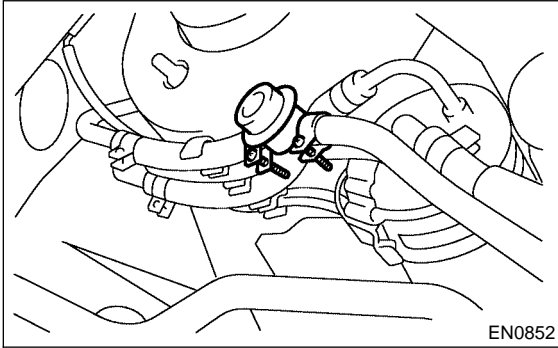

### B: INSTALLATION S185708A11

Install in the reverse order of removal.

## 30. Fuel Delivery, Return and Evaporation Lines

S185019

### A: REMOVAL

S185019A18

- 1) Set vehicle on the lift.
- 2) Release fuel pressure. <Ref. to FU(DOHC TURBO)-50, RELEASING OF FUEL PRESSURE, OPERATION, Fuel.>

- 3) Open fuel filler flap lid and remove fuel filler cap.
- 4) Remove floor mat. <Ref. to EI-43, REMOVAL, Floor Mat.>
- 5) Remove fuel delivery pipes and hoses, fuel return pipes and hoses, evaporation pipes and hoses.

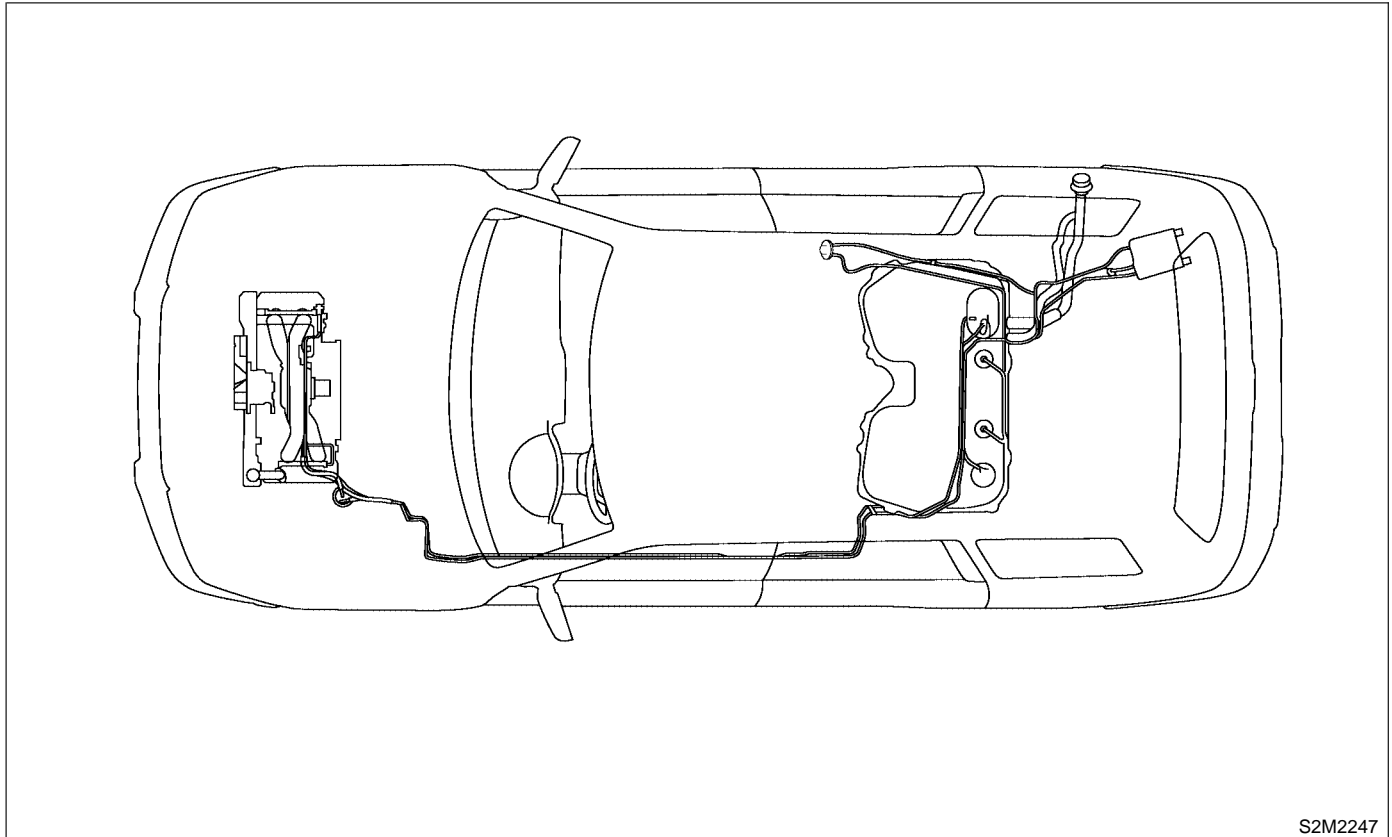

S2M2247

- 6) In engine compartment, detach fuel delivery hoses, return hoses and evaporation hose.

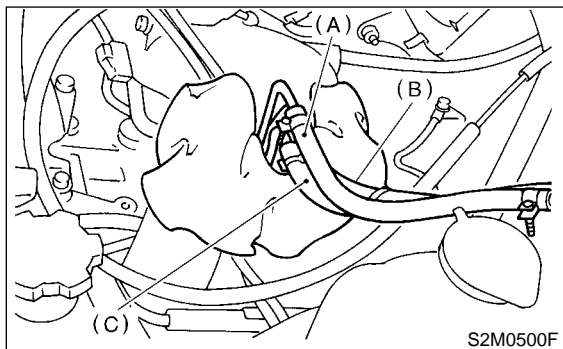

S2M0500F

- (A) Fuel delivery hose
- (B) Return hose
- (C) Evaporation hose

- 8) Disconnect two-way valve hose (A) from two-way valve and disconnect canister hose (B) from canister.

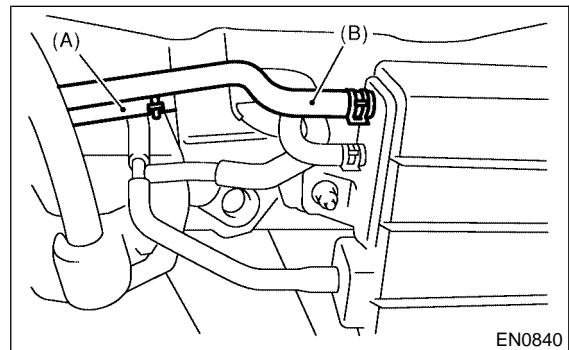

EN0840

- 7) Lift-up the vehicle.

# FUEL DELIVERY, RETURN AND EVAPORATION LINES

## Fuel Injection (Fuel Systems)

9) Separate quick connector on fuel delivery and return line.

- (1) Clean pipe and connector, if they are covered with dust.
- (2) Hold connector (A) and push retainer (B) down.
- (3) Pull out connector (A) from retainer (B).

### CAUTION:

Replace retainers with new ones.

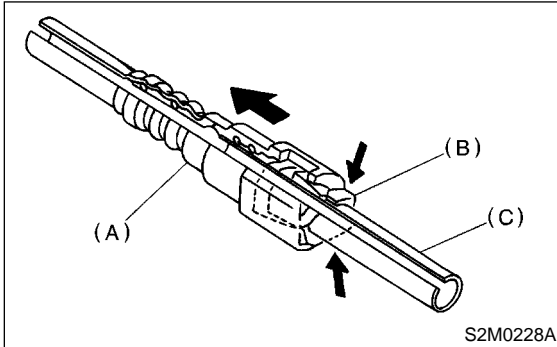

- (A) Connector
- (B) Retainer
- (C) Pipe

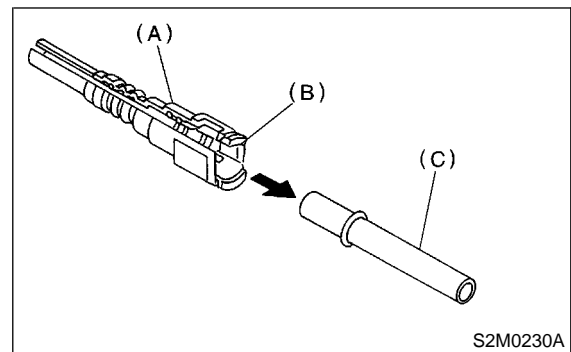

- (A) Connector
- (B) Retainer
- (C) Pipe

### CAUTION:

- Pull the connector to ensure it is connected securely.
- Ensure the two retainer pawls are engaged in their mating positions in the connector.
- Be sure to inspect hoses and their connections for any leakage of fuel.

## B: INSTALLATION

S185019A11

1) Connect quick connector on fuel delivery line.

### CAUTION:

- Always use a new retainer.
- Make sure that the connected portion is not damaged or has dust. If necessary, clean seal surface of pipe.

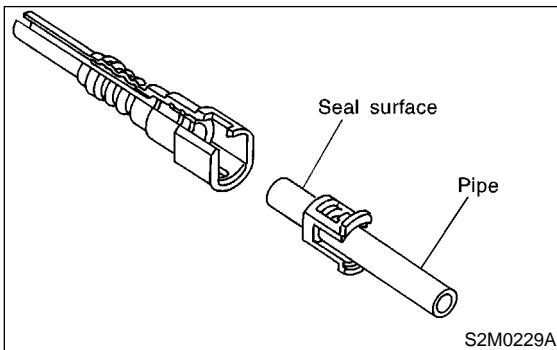

- (1) Set new retainer (B) to connector (A).
- (2) Push pipe into connector completely.

### NOTE:

At this time, two clicking sounds are heard.

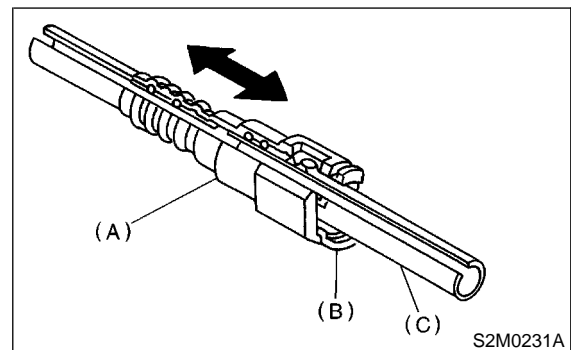

- (A) Connector
- (B) Retainer
- (C) Pipe

# FUEL DELIVERY, RETURN AND EVAPORATION LINES

Fuel Injection (Fuel Systems)

2) Connect fuel delivery hose to pipe with an overlap of 20 to 25 mm (0.79 to 0.98 in).

Type A: When fitting length is specified.

Type B: When fitting length is not specified.

$\ell$ :  $2.5 \pm 1.5$  mm ( $0.098 \pm 0.059$  in)

$L$ :  $22.5 \pm 2.5$  mm ( $0.886 \pm 0.098$  in)

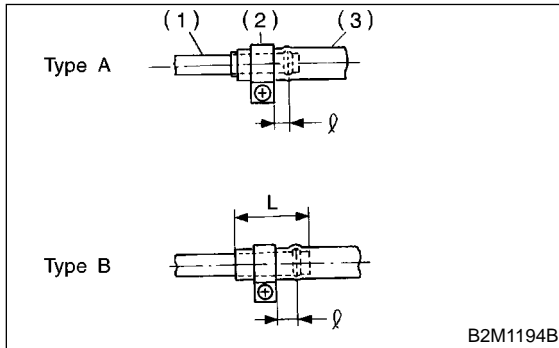

- (1) Fitting
- (2) Clamp
- (3) Hose

3) Connect evaporation hose to pipe by approx. 15 mm (0.59 in) from hose end.

$L = 17.5 \pm 2.5$  mm ( $0.689 \pm 0.098$  in)

## CAUTION:

Be sure to inspect hoses and their connections for any leakage of fuel.

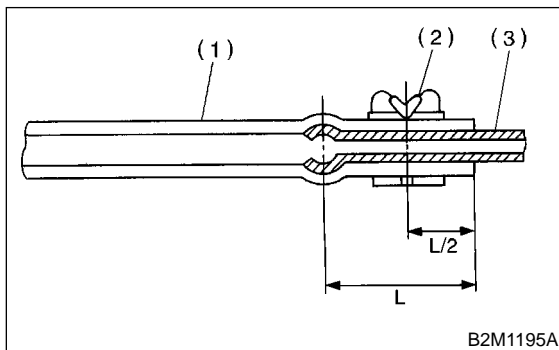

- (1) Hose
- (2) Clip
- (3) Pipe

## C: INSPECTION S185019A10

1) Make sure that there are no cracks on the fuel pipes and fuel hoses.

2) Make sure that the fuel pipe and fuel hose connections are tight.

# FUEL SYSTEM TROUBLE IN GENERAL

Fuel Injection (Fuel Systems)

## 31. Fuel System Trouble in General

S185571

### A: INSPECTION

S185571A10

Trouble and possible cause		Corrective action
<b>1. Insufficient fuel supply to the injector</b>		
1)	Fuel pump will not operate.	
	<input type="radio"/> Defective terminal contact.	Inspect connections, especially ground, and tighten securely.
	<input type="radio"/> Trouble in electromagnetic or electronic circuit parts.	Replace fuel pump.
2)	Lowering of fuel pump function.	Replace fuel pump.
3)	Clogged dust or water in the fuel filter.	Replace fuel filter, clean or replace fuel tank.
4)	Clogged or bent fuel pipe or hose.	Clean, correct or replace fuel pipe or hose.
5)	Air is mixed in the fuel system.	Inspect or retighten each connection part.
6)	Clogged or bent breather tube or pipe.	Clean, correct or replace air breather tube or pipe.
7)	Damaged diaphragm of pressure regulator.	Replace.
<b>2. Leakage or blow out fuel</b>		
1)	Loosened joints of the fuel pipe.	Retightening.
2)	Cracked fuel pipe, hose and fuel tank.	Replace.
3)	Defective welding part on the fuel tank.	Replace.
4)	Defective drain packing of the fuel tank.	Replace.
5)	Clogged or bent air breather tube or air vent tube.	Clean, correct or replace air breather tube or air vent tube.
<b>3. Gasoline smell inside of compartment</b>		
1)	Loose joints at air breather tube, air vent tube and fuel filler pipe.	Retightening.
2)	Defective packing air tightness on the fuel saucer.	Correct or replace packing.
3)	Cracked fuel separator.	Replace separator.
4)	Inoperative fuel pump modulator or circuit.	Replace.
<b>4. Defective fuel meter indicator</b>		
1)	Defective operation of fuel level sensor.	Replace.
2)	Defective operation of fuel meter.	Replace.
<b>5. Noise</b>		
1)	Large operation noise or vibration of fuel pump.	Replace.

#### NOTE:

● When the vehicle is left unattended for an extended period of time, water may accumulate in the fuel tank.

To prevent water condensation:

(1) Top off the fuel tank or drain the fuel completely.

(2) Drain water condensation from the fuel filter.

● Refilling the fuel tank.

Refill the fuel tank while there is still some fuel left in the tank.

● Protecting the fuel system against freezing and water condensation.

(1) Cold areas

In snow-covered areas, mountainous areas, skiing areas, etc. where ambient temperatures drop below 0°C (32°F) throughout the winter season, use an anti-freeze solution in the cool-

ing system. Refueling will also complement the effect of anti-freeze solution each time the fuel level drops to about one-half. After the winter season, drain water which may have accumulated in the fuel filter and fuel tank in the manner same as that described under Affected areas below.

(2) Affected areas

When water condensation is noticed in the fuel filter, drain water from both the fuel filter and fuel tank or use a water removing agent (or anti-freeze solution) in the fuel tank.

● Observe the instructions, notes, etc., indicated on the label affixed to the anti-freeze solution (water removing agent) container before use.