

TRANSMISSION SECTION

This service manual has been prepared to provide SUBARU service personnel with the necessary information and data for the correct maintenance and repair of SUBARU vehicles.

This manual includes the procedures for maintenance, disassembling, reassembling, inspection and adjustment of components and diagnostics for guidance of experienced mechanics.

Please peruse and utilize this manual fully to ensure complete repair work for satisfying our customers by keeping their vehicle in optimum condition. When replacement of parts during repair work is needed, be sure to use SUBARU genuine parts.

All information, illustration and specifications contained in this manual are based on the latest product information available at the time of publication approval.

FUJI HEAVY INDUSTRIES LTD.

CONTROL SYSTEMS CS

AUTOMATIC TRANSMISSION AT

**MANUAL TRANSMISSION
AND DIFFERENTIAL** MT

CLUTCH SYSTEM CL

**AUTOMATIC TRANSMISSION
(DIAGNOSTICS)** AT

AUTOMATIC TRANSMISSION (DIAGNOSTICS)

AT

	Page
1. Basic Diagnostic Procedure	2
2. Check List for Interview.....	4
3. General Description.....	5
4. Electrical Components Location.....	8
5. Transmission Control Module (TCM) I/O Signal	15
6. Subaru Select Monitor.....	20
7. Read Diagnostic Trouble Code	22
8. Inspection Mode	24
9. Clear Memory Mode.....	25
10. Power Indicator Light Display	26
11. List of Diagnostic Trouble Code.....	27
12. Diagnostic Procedure for Power Indicator Light	28
13. Diagnostic Procedure for Select Monitor Communication	36
14. Diagnostic Procedure with Trouble Code	42
15. Diagnostic Procedure for No-trouble Code.....	107
16. Symptom Related Diagnostic.....	134

BASIC DIAGNOSTIC PROCEDURE

Automatic Transmission (Diagnostics)

1. Basic Diagnostic Procedure S004501

A: PROCEDURE S004501E45

No.	Step	Check	Yes	No
1	<p>CHECK PRE-INSPECTION.</p> <p>1) Ask the customer when and how the trouble occurred using interview checklist. <Ref. to AT-4, Check List for Interview.></p> <p>2) Before performing diagnosis, inspect the following items which might influence the AT problems.</p> <ul style="list-style-type: none"> ● General inspection <Ref. to AT-5, INSPECTION, General Description.> ● Oil leak ● Stall speed test <Ref. to AT-13, Stall Test.> ● Line pressure test <Ref. to AT-16, Line Pressure Test.> ● Transfer clutch pressure test <Ref. to AT-18, Transfer Clutch Pressure Test.> ● Time lag test <Ref. to AT-15, Time Lag Test.> ● Road test <Ref. to AT-12, Road Test.> ● Inhibitor switch <Ref. to AT-28, Inhibitor Switch.> 	Is unit that might influence the AT problem normal?	Go to step 2.	Repair or replace each item.
2	<p>CHECK POWER INDICATOR LIGHT.</p> <p>Turn ignition switch to ON.</p>	Does not the POWER indicator light light up?	Go to step 3.	Go to step 4.
3	<p>CHECK POWER INDICATOR LIGHT.</p> <p>1) Turn ignition switch to OFF.</p> <p>2) Repair POWER indicator light circuit or power supply and ground line circuit. <Ref. to AT-28, Diagnostic Procedure for Power Indicator Light.></p> <p>3) Turn ignition switch to ON.</p>	Is the POWER indicator light flashing?	Go to step 4.	Go to step 5.
4	<p>CHECK INDICATION OF TROUBLE CODE.</p> <p>Calling up trouble code.</p> <p>Without SUBARU SELECT MONITOR <Ref. to AT-22, WITHOUT SUBARU SELECT MONITOR, OPERATION, Read Diagnostic Trouble Code.></p> <p>With SUBARU SELECT MONITOR <Ref. to AT-23, WITH SUBARU SELECT MONITOR, OPERATION, Read Diagnostic Trouble Code.></p> <p>NOTE:</p> <p>If the communication function of the select monitor cannot be executed normally, check the communication circuit. <Ref. to AT-36, COMMUNICATION FOR INITIALIZING IMPOSSIBLE, Diagnostic Procedure for Select Monitor Communication.></p>	Is the trouble code displayed?	Go to step 6. NOTE: Record all trouble codes.	Go to step 5.

BASIC DIAGNOSTIC PROCEDURE

Automatic Transmission (Diagnostics)

No.	Step	Check	Yes	No
5	<p>PERFORM THE GENERAL DIAGNOSTICS.</p> <p>1) Inspect using "Diagnostic Procedure for No-trouble Code".<Ref. to AT-107, Diagnostic Procedure for No-trouble Code.></p> <p>2) Inspect using "Symptom Related Diagnostic". <Ref. to AT-134, Symptom Related Diagnostic.></p> <p>3) Perform the clear memory mode. With SUBARU SELECT MONITOR <Ref. to AT-25, WITH SUBARU SELECT MONITOR, OPERATION, Clear Memory Mode.> Without SUBARU SELECT MONITOR <Ref. to AT-25, WITHOUT SUBARU SELECT MONITOR, OPERATION, Clear Memory Mode.></p> <p>4) Perform the inspection mode. <Ref. to AT-24, Inspection Mode.> Calling up the trouble code. Without SUBARU SELECT MONITOR <Ref. to AT-22, WITHOUT SUBARU SELECT MONITOR, OPERATION, Read Diagnostic Trouble Code.> With SUBARU SELECT MONITOR <Ref. to AT-23, WITH SUBARU SELECT MONITOR, OPERATION, Read Diagnostic Trouble Code.></p>	Is the trouble code displayed?	Go to step 6.	Complete the diagnosis.
6	<p>PERFORM THE DIAGNOSIS.</p> <p>1) Inspect using "Diagnostics Chart with Trouble Code".<Ref. to AT-42, Diagnostic Procedure with Trouble Code.> NOTE: For trouble code table, refer to "List of Diagnostic Trouble Code".<Ref. to AT-27, List of Diagnostic Trouble Code.></p> <p>2) Repair trouble cause.</p> <p>3) Perform the clear memory mode. With SUBARU SELECT MONITOR <Ref. to AT-25, WITH SUBARU SELECT MONITOR, OPERATION, Clear Memory Mode.> Without SUBARU SELECT MONITOR <Ref. to AT-25, WITHOUT SUBARU SELECT MONITOR, OPERATION, Clear Memory Mode.></p> <p>4) Perform the inspection mode. <Ref. to AT-24, Inspection Mode.></p> <p>5) Calling up the trouble code. Without SUBARU SELECT MONITOR <Ref. to AT-22, WITHOUT SUBARU SELECT MONITOR, OPERATION, Read Diagnostic Trouble Code.> With SUBARU SELECT MONITOR <Ref. to AT-23, WITH SUBARU SELECT MONITOR, OPERATION, Read Diagnostic Trouble Code.></p>	Is the trouble code displayed?	Inspect using "Diagnostics Chart with Diagnostic Connector". <Ref. to AT-42, Diagnostic Procedure with Trouble Code.>	Complete the diagnosis.

CHECK LIST FOR INTERVIEW

Automatic Transmission (Diagnostics)

2. Check List for Interview S004502

A: CHECK S004502A04

Check the following items when problem has occurred.

NOTE:

Use copies of this page for interviewing customers.

Customer's name		
Data vehicle brought in		
Data of repair		
Trans. model	TRANSMISSION	VIN
Odometer reading	km/h or mile	
Frequency	<input type="checkbox"/> Continuous <input type="checkbox"/> Intermittent (times a day)	
Weather	<input type="checkbox"/> Fine <input type="checkbox"/> Cloudy <input type="checkbox"/> Rainy <input type="checkbox"/> Snowy <input type="checkbox"/> Various/Others ()	
Place	<input type="checkbox"/> Highway <input type="checkbox"/> Suburbs <input type="checkbox"/> Inner city <input type="checkbox"/> Uphill <input type="checkbox"/> Rough road <input type="checkbox"/> Others ()	
Outdoor temperature	<input type="checkbox"/> Hot <input type="checkbox"/> Warm <input type="checkbox"/> Cool <input type="checkbox"/> Cold	
Vehicle speed	km/h (MPH)	
Malfunction indicator lamp (MIL)	<input type="checkbox"/> Continuously lit	<input type="checkbox"/> Not lit
Select lever position	<input type="checkbox"/> P <input type="checkbox"/> R <input type="checkbox"/> N <input type="checkbox"/> D <input type="checkbox"/> 3 <input type="checkbox"/> 2 <input type="checkbox"/> 1	
Driving condition	<input type="checkbox"/> Not affected <input type="checkbox"/> At racing <input type="checkbox"/> While decelerating	<input type="checkbox"/> At starting <input type="checkbox"/> While accelerating <input type="checkbox"/> While turning (<input type="checkbox"/> RH/ <input type="checkbox"/> LH) <input type="checkbox"/> While idling <input type="checkbox"/> While cruising
POWER switch	<input type="checkbox"/> ON <input type="checkbox"/> OFF	
HOLD switch	<input type="checkbox"/> ON <input type="checkbox"/> OFF	
Symptoms	<input type="checkbox"/> No up-shift	
	<input type="checkbox"/> No down-shift	
	<input type="checkbox"/> No kick down	
	<input type="checkbox"/> Vehicle does not move (<input type="checkbox"/> Any position <input type="checkbox"/> Particular position)	
	<input type="checkbox"/> Lock-up malfunction	
	<input type="checkbox"/> Noise or vibration	
	<input type="checkbox"/> Shift shock or slip	
	<input type="checkbox"/> Select lever does not move	
<input type="checkbox"/> Others ()		

3. General Description S004001

A: CAUTION S004001A03

- **Supplemental Restraint System “Airbag”**
Airbag system wiring harness is routed near the transmission control module (TCM).

CAUTION:

- All airbag system wiring harness and connectors are colored yellow. Do not use electrical test equipment on these circuit.
- Be careful not to damage airbag system wiring harness when performing diagnostics and servicing the TCM.

- **Measurement**

When measuring voltage and resistance of the ECM, TCM or each sensor, use a tapered pin with a diameter of less than 0.64 mm (0.025 in) in order to avoid poor contact. Do not insert the pin more than 6.5 mm (0.256 in).

B: INSPECTION S004001A10

1. BATTERY S004001A1001

Measure battery voltage and specific gravity of electrolyte.

Standard voltage: 12V or more

Specific gravity: Above 1.260

2. TRANSMISSION GROUND S004001A1002

Make sure that the ground terminal bolt is tightened securely.

- **Chassis side**

Tightening torque:

13 N·m (1.3 kgf·m, 9.4 ft·lb)

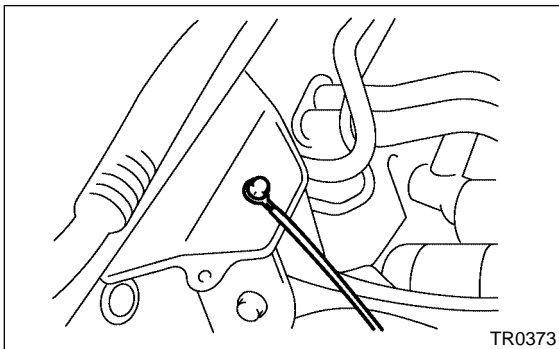

3. ATF LEVEL S004001A1003

Make sure that ATF level is in the specification.

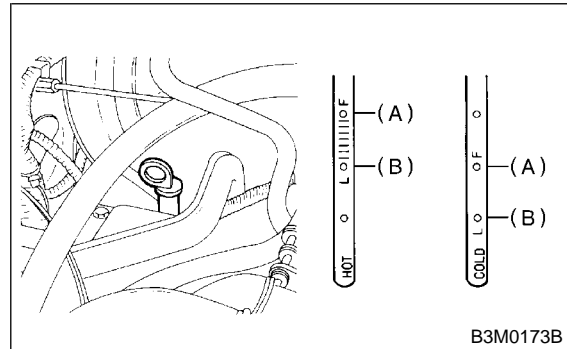

- (A) Upper level
- (B) Lower level

4. FRONT DIFFERENTIAL OIL LEVEL

S004001A1004

Make sure that front differential oil level is in the specification.

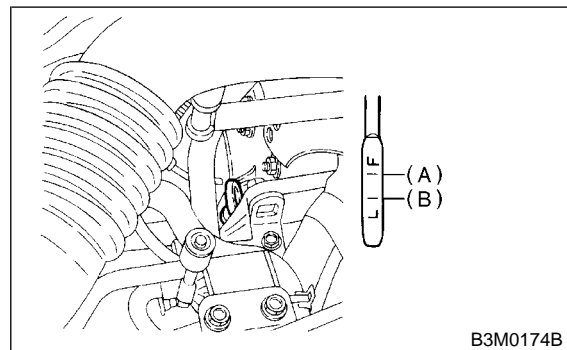

- (A) Upper level
- (B) Lower level

GENERAL DESCRIPTION

Automatic Transmission (Diagnostics)

5. OPERATION OF SHIFT SELECT LEVER

S004001A1005

WARNING:

Stop the engine while checking operation of select lever.

- 1) Check that select lever does not move from "N" to "R" without pushing the button.
- 2) Check that select lever does not move from "R" to "P" without pushing the button.
- 3) Check that select lever does not move from "P" to "R" without pushing the button.
- 4) Check that select lever does not move from "3" to "2" without pushing the button.

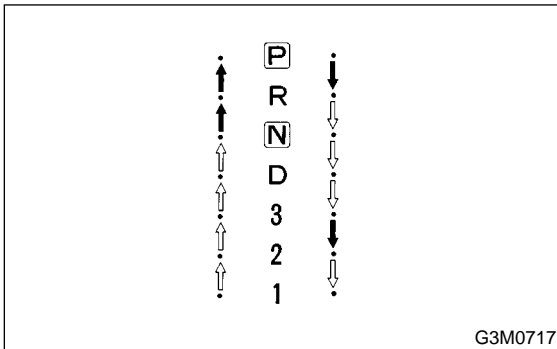

6. POWER SWITCH

S004001A1006

Make sure that POWER indicator light in combination meter comes ON, when turning power switch to ON.

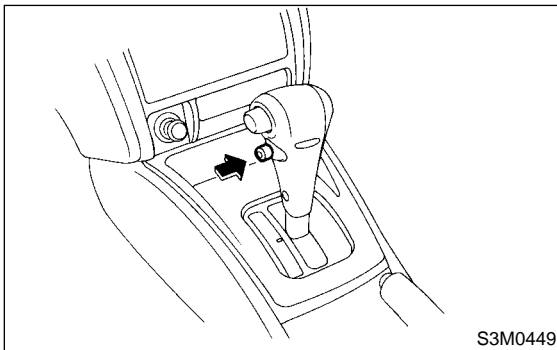

7. HOLD SWITCH

S004001A1007

Make sure that HOLD indicator light in combination meter comes ON, when turning hold switch to ON.

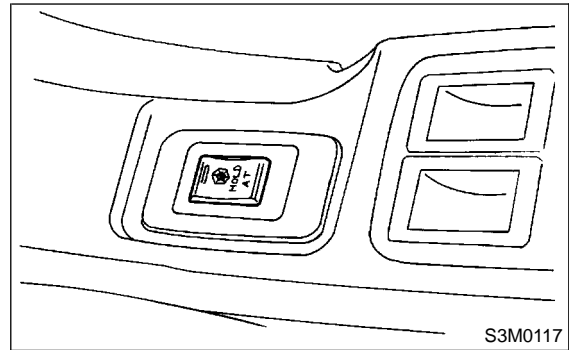



GENERAL DESCRIPTION

Automatic Transmission (Diagnostics)

C: PREPARATION TOOL S004001A17

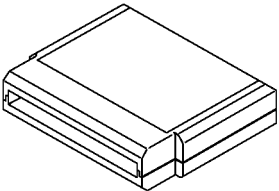
1. SPECIAL TOOLS S004001A1701

ILLUSTRATION	TOOL NUMBER	DESCRIPTION	REMARKS
 <p style="text-align: center;">B2M3876</p>	24082AA150 (Newly adopted tool)	CARTRIDGE	Troubleshooting for electrical systems.
 <p style="text-align: center;">B2M3877</p>	22771AA030	SELECT MONITOR KIT	Troubleshooting for electrical systems. <ul style="list-style-type: none"> ● English: 22771AA030 (Without printer) ● German: 22771AA070 (Without printer) ● French: 22771AA080 (Without printer) ● Spanish: 22771AA090 (Without printer)

2. GENERAL PURPOSE TOOLS S004001A1702

TOOL NAME	REMARKS
Circuit Tester	Used for measuring resistance, voltage and ampere.
Oscilloscope	Used for measuring sensor.

ELECTRICAL COMPONENTS LOCATION

Automatic Transmission (Diagnostics)

4. Electrical Components Location S004507

A: LOCATION S004507A13

1. CONTROL MODULE FOR MODEL WITHOUT OBD S004507A1304

● LHD MODEL

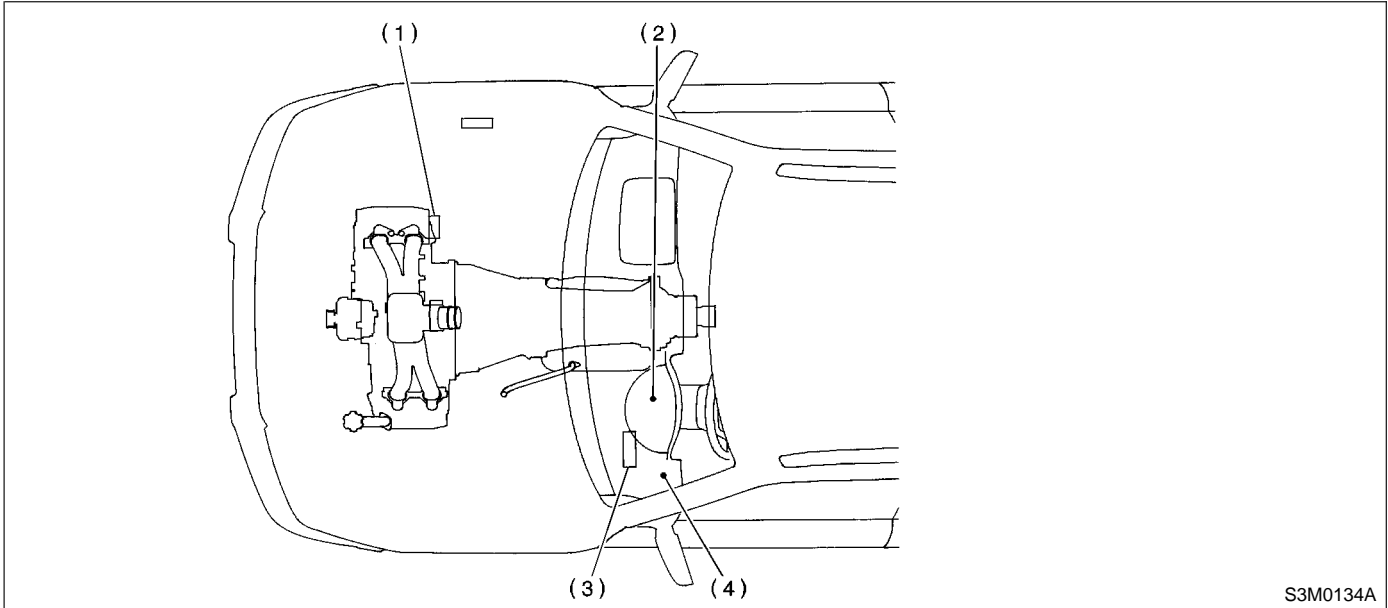

S3M0134A

● RHD MODEL

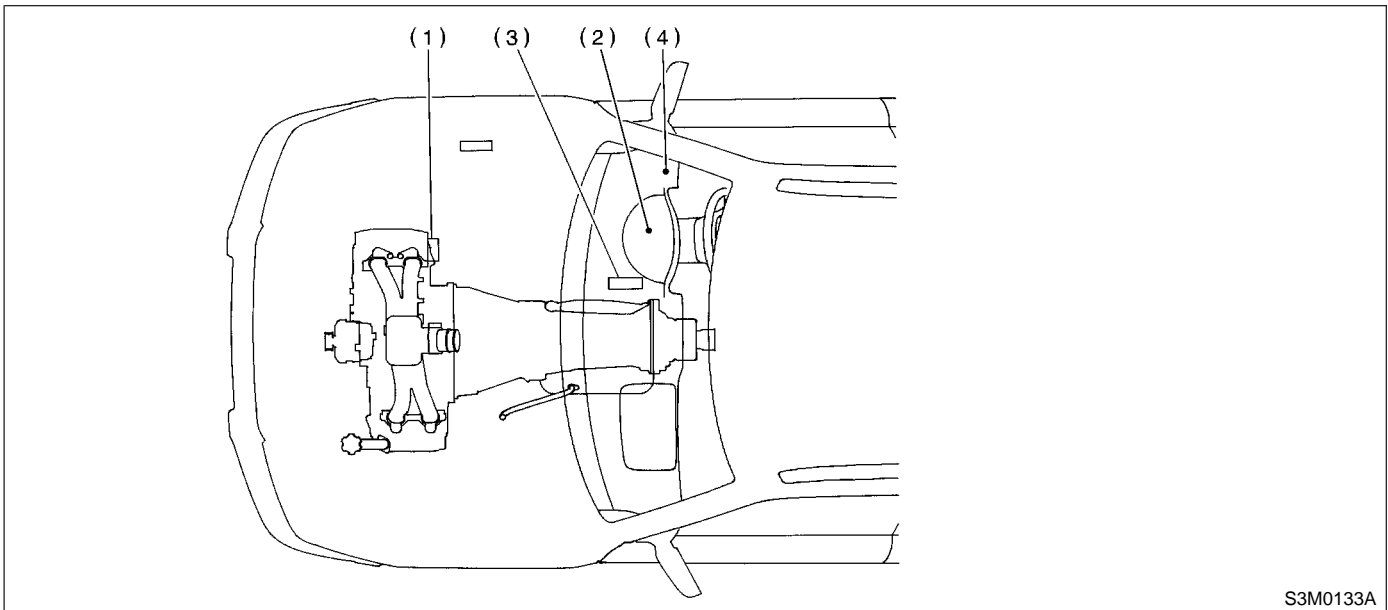

S3M0133A

- | | |
|---|---------------------------------------|
| (1) Engine control module (ECM) | (3) Transmission control module (TCM) |
| (2) Power indicator light (AT diagnostic indicator light) | (4) Data link connector |

ELECTRICAL COMPONENTS LOCATION

Automatic Transmission (Diagnostics)

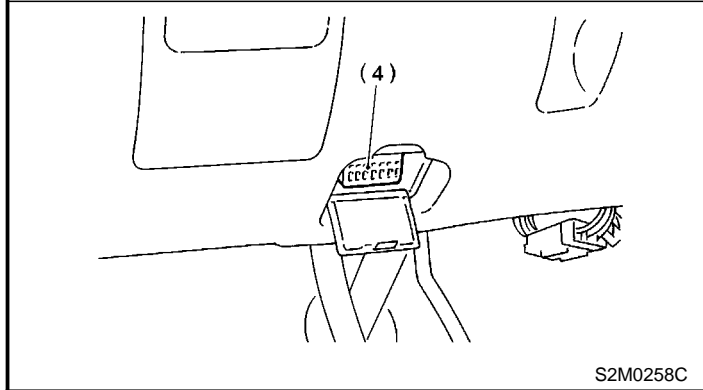
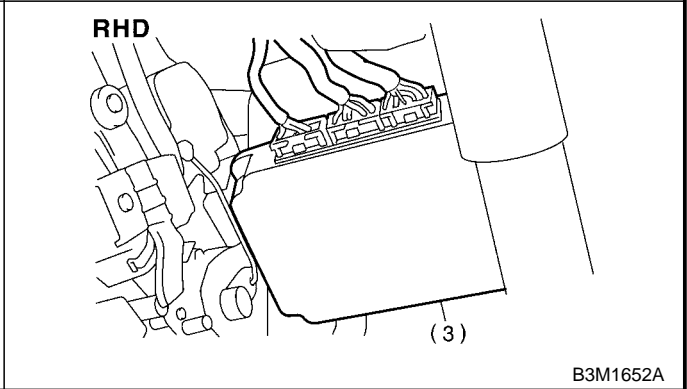
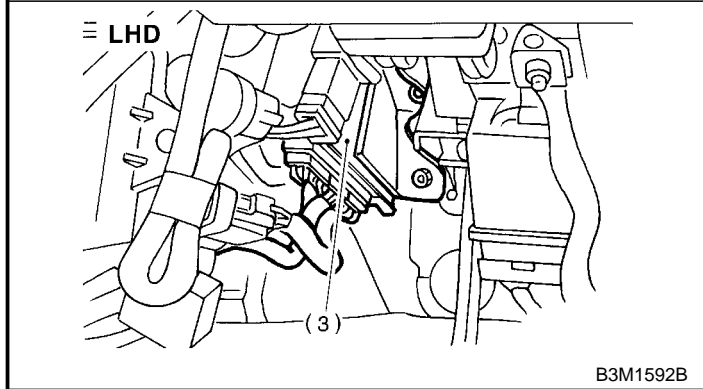
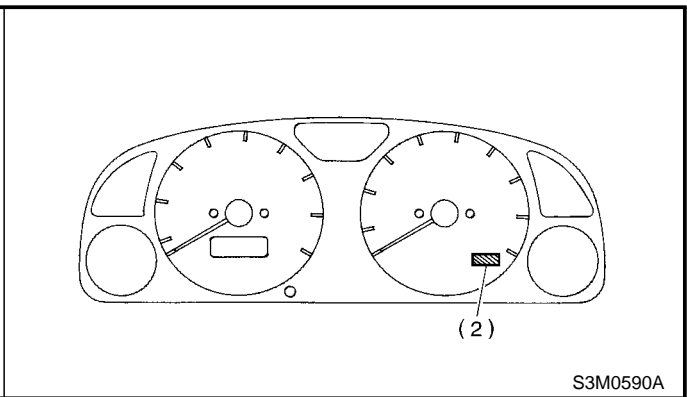
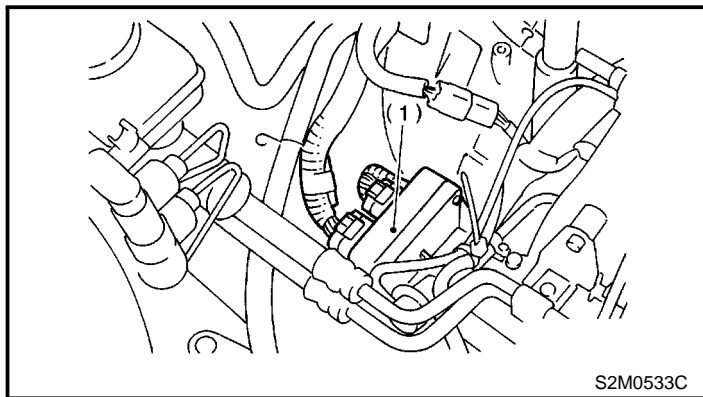

ELECTRICAL COMPONENTS LOCATION

Automatic Transmission (Diagnostics)

2. CONTROL MODULE FOR MODEL WITH OBD S004507A1305

● LHD MODEL

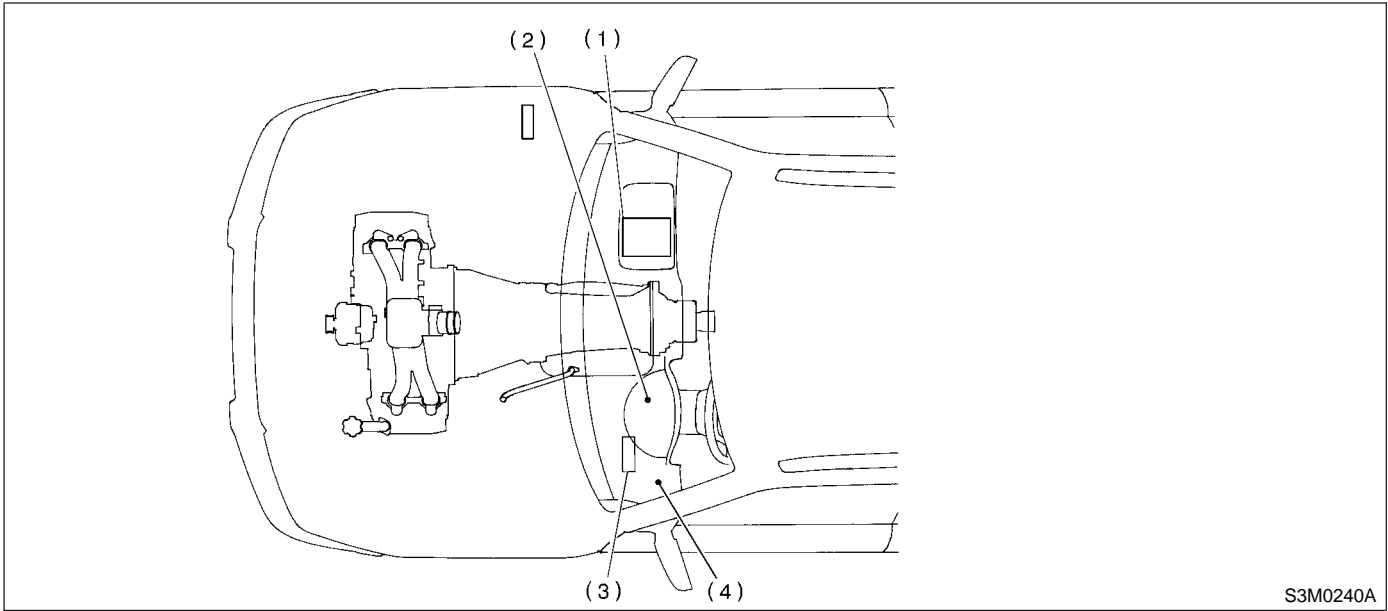

S3M0240A

● RHD MODEL

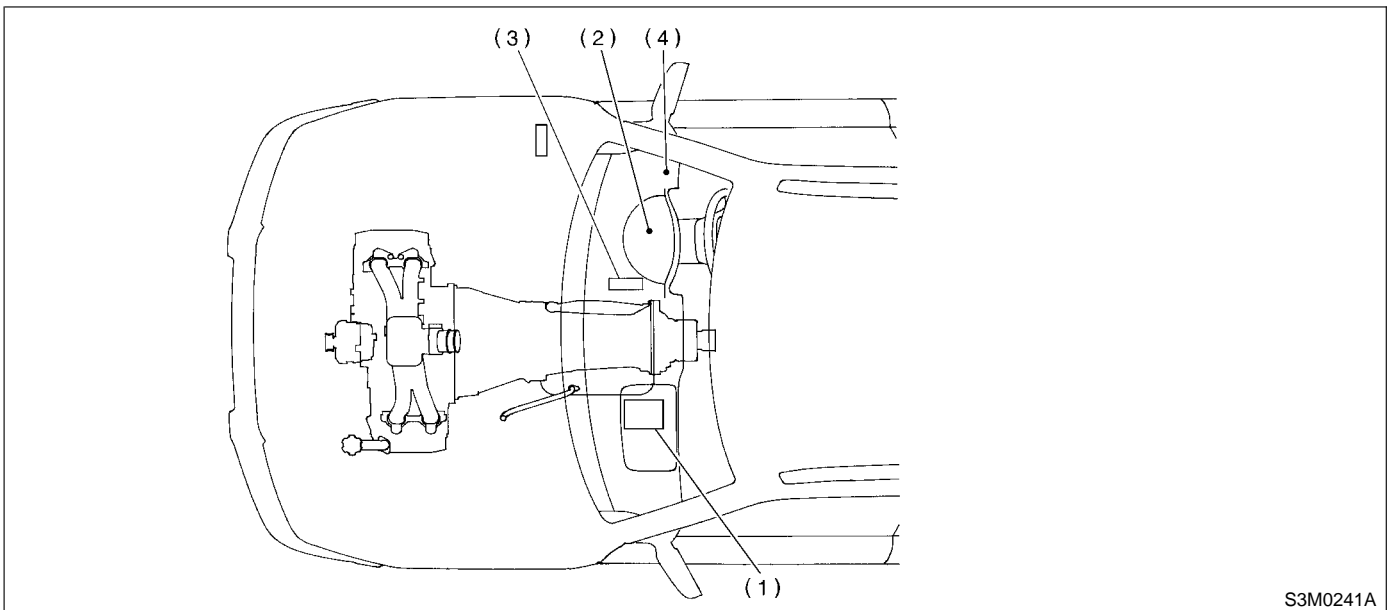

S3M0241A

- | | |
|---|---------------------------------------|
| (1) Engine control module (ECM) | (3) Transmission control module (TCM) |
| (2) Power indicator light (AT diagnostic indicator light) | (4) Data link connector |

ELECTRICAL COMPONENTS LOCATION

Automatic Transmission (Diagnostics)

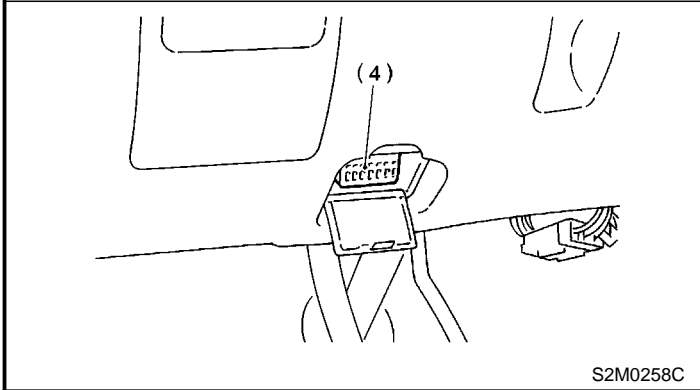
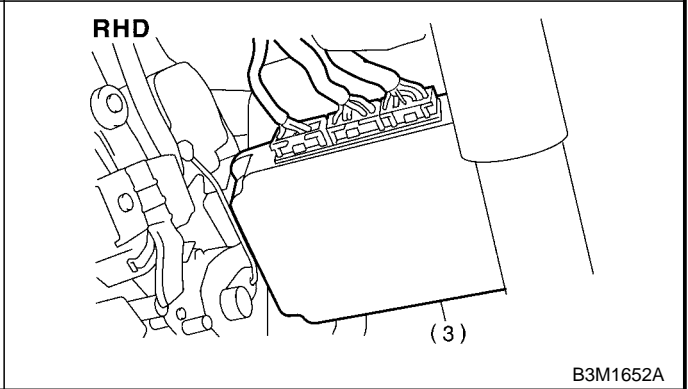
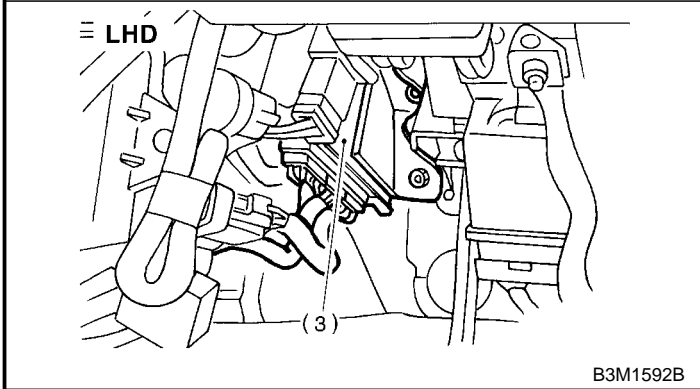
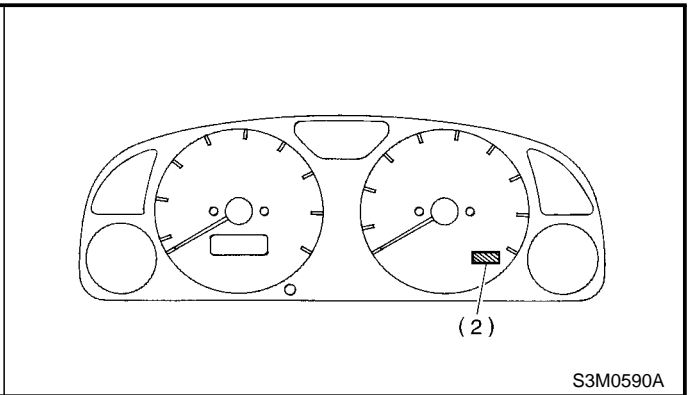
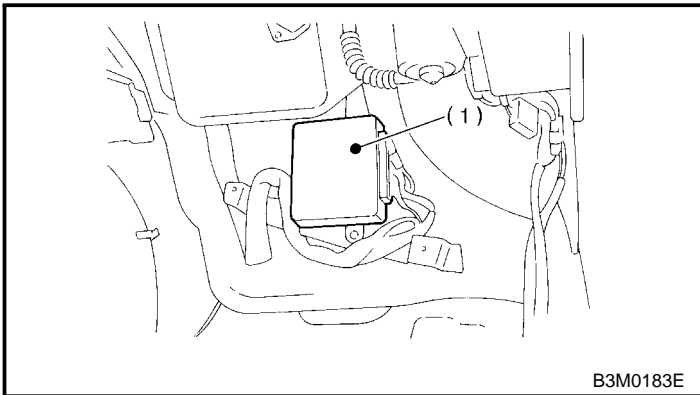

ELECTRICAL COMPONENTS LOCATION

Automatic Transmission (Diagnostics)

3. SENSOR S004507A1302

● LHD MODEL

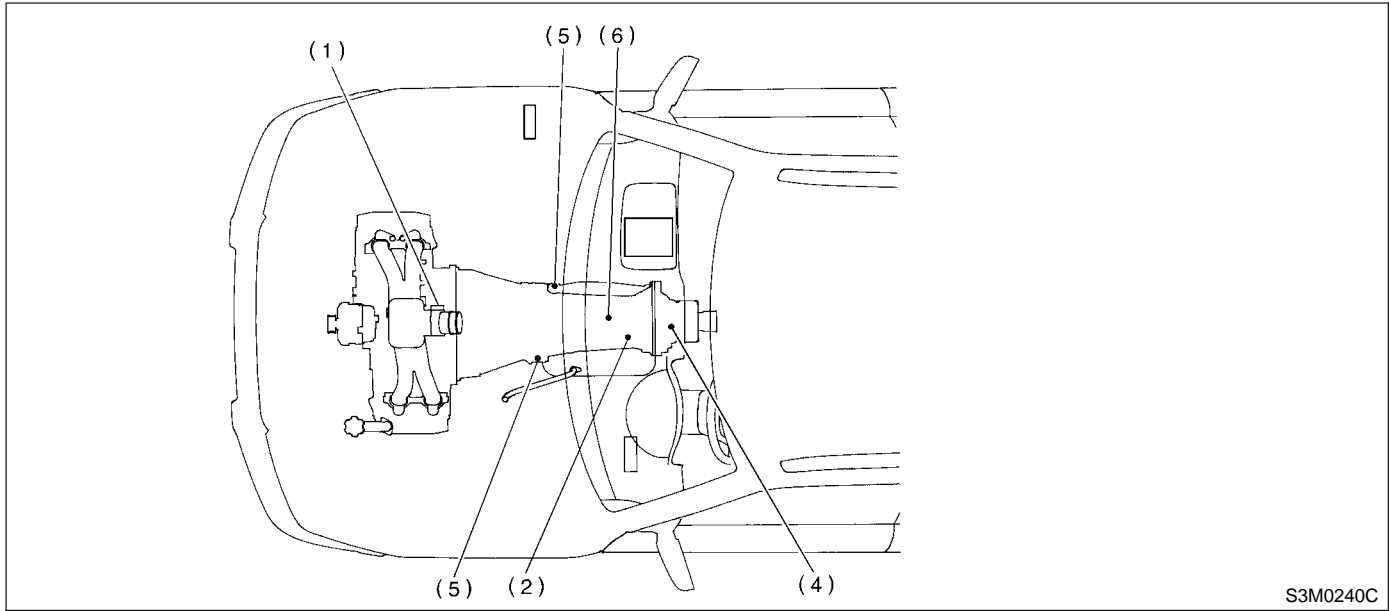

S3M0240C

● RHD MODEL

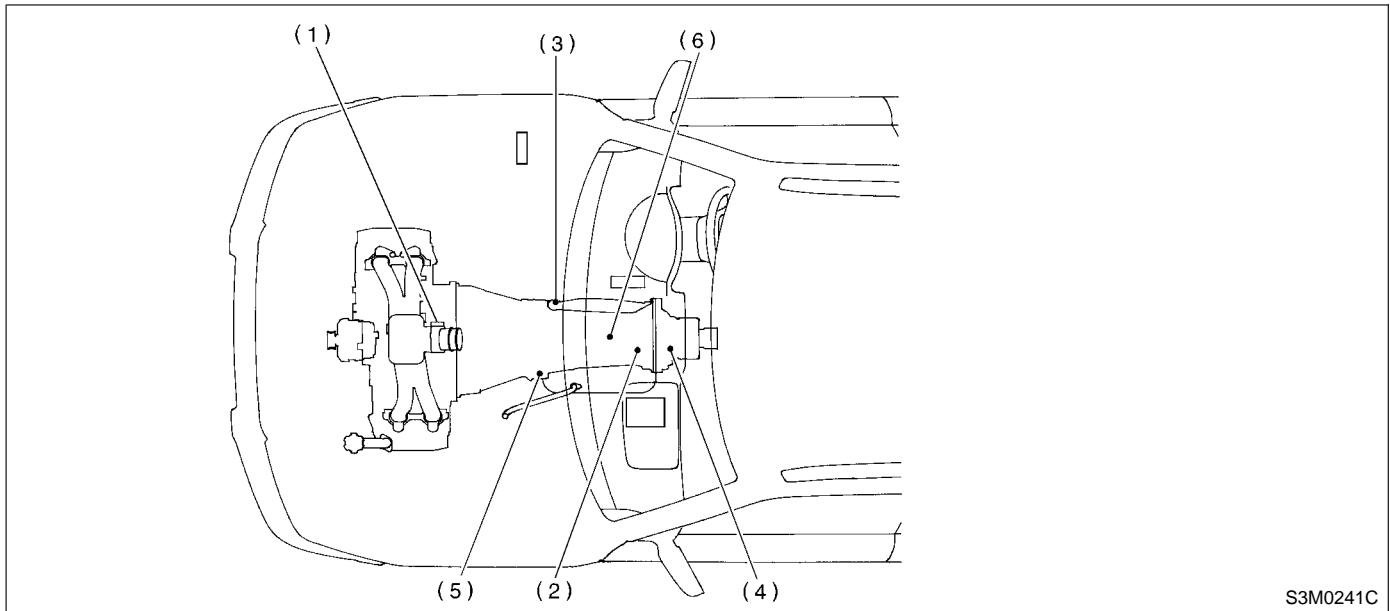

S3M0241C

- | | | |
|--------------------------------|---|----------------------------|
| (1) Throttle position sensor | (4) Rear vehicle speed sensor | (6) ATF temperature sensor |
| (2) Front vehicle speed sensor | (5) Torque converter turbine speed sensor | |
| (3) Inhibitor switch | | |

ELECTRICAL COMPONENTS LOCATION

Automatic Transmission (Diagnostics)

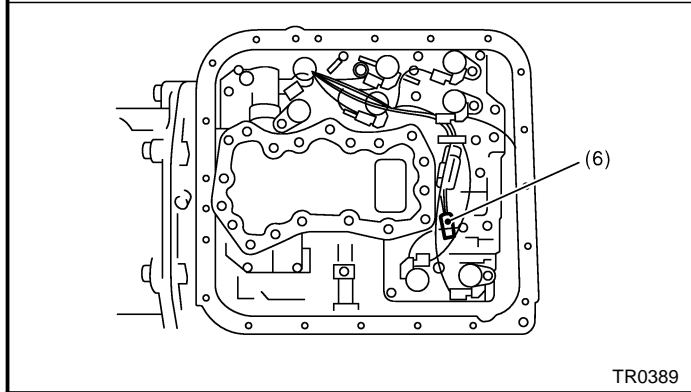
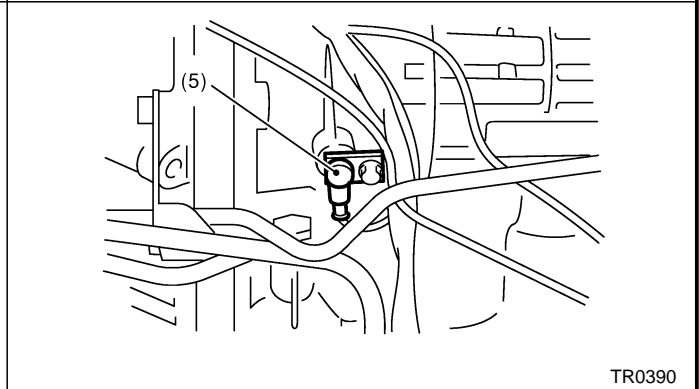
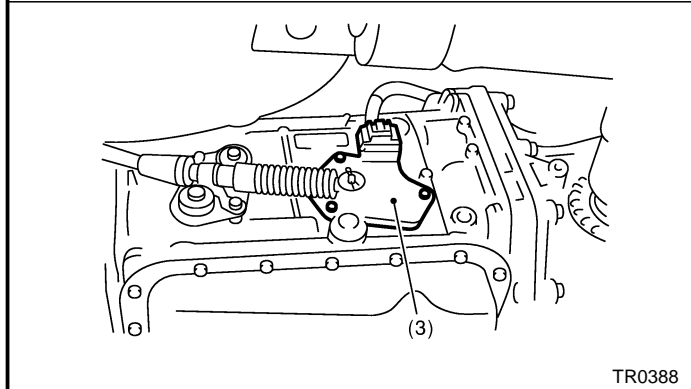
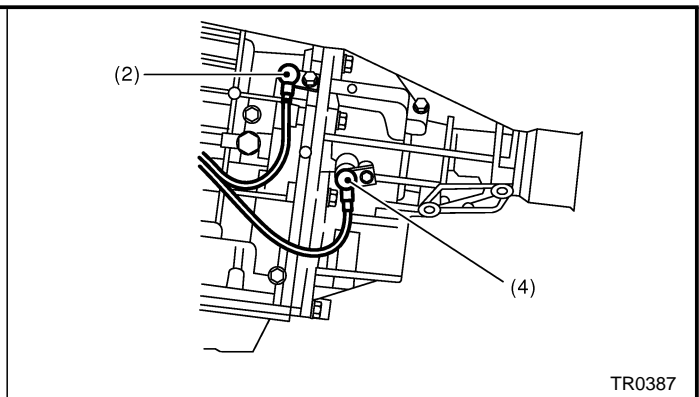
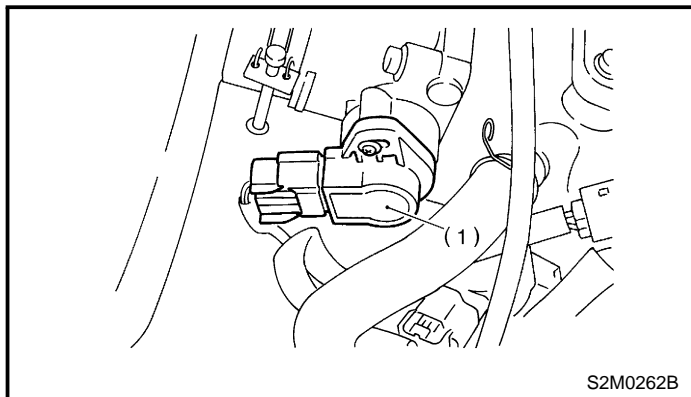

ELECTRICAL COMPONENTS LOCATION

Automatic Transmission (Diagnostics)

4. SOLENOID S004507A1303

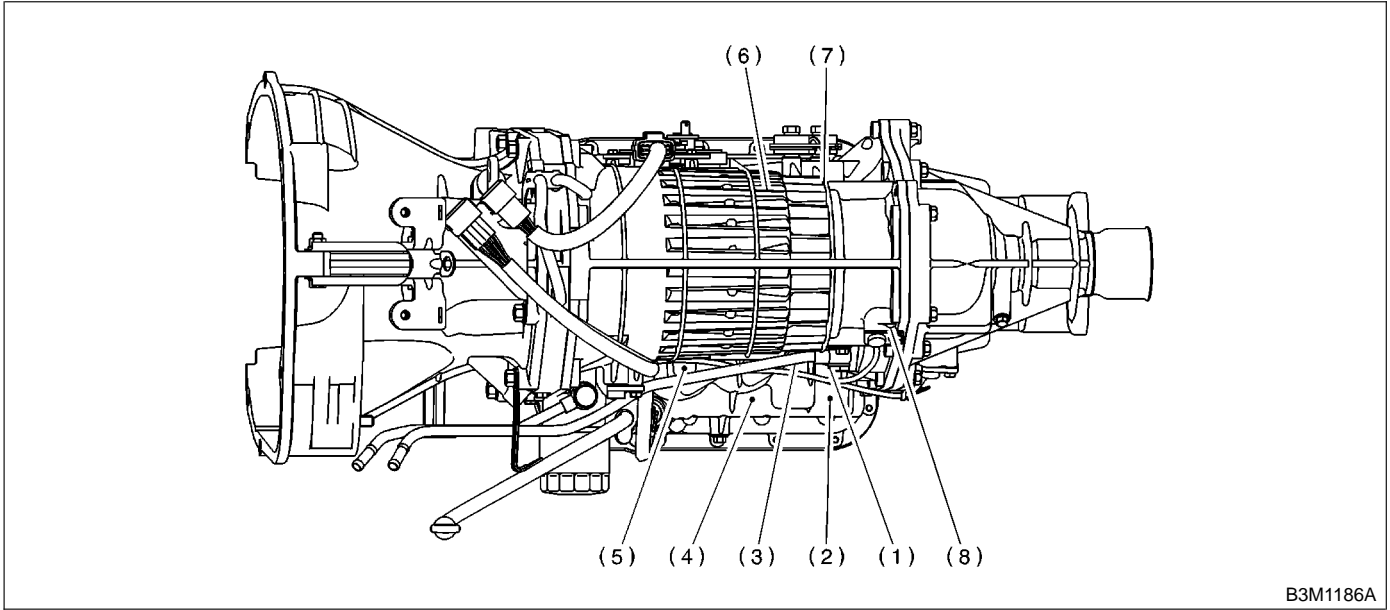

- | | | |
|---------------------------------|--------------------------------|-------------------------------|
| (1) Solenoid 1 | (4) Low clutch timing solenoid | (7) 2-4 brake timing solenoid |
| (2) Solenoid 2 | (5) Lock-up duty solenoid | (8) Transfer duty solenoid |
| (3) Line pressure duty solenoid | (6) 2-4 brake duty solenoid | |

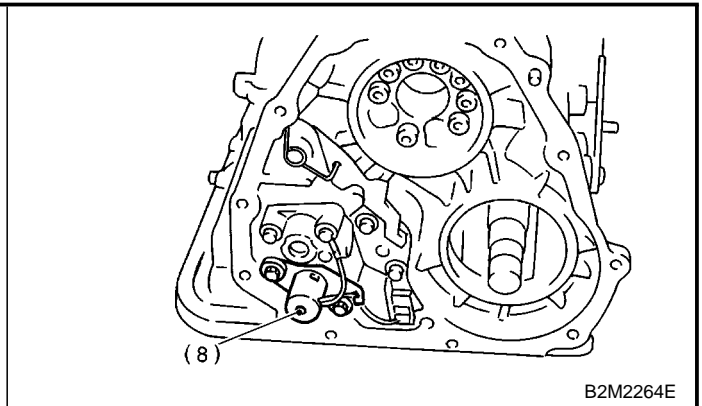
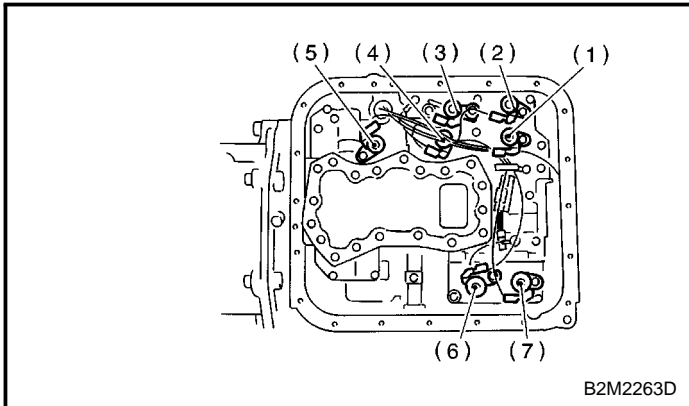

5. Transmission Control Module (TCM) I/O Signal S004506

A: ELECTRICAL SPECIFICATION S004506A08

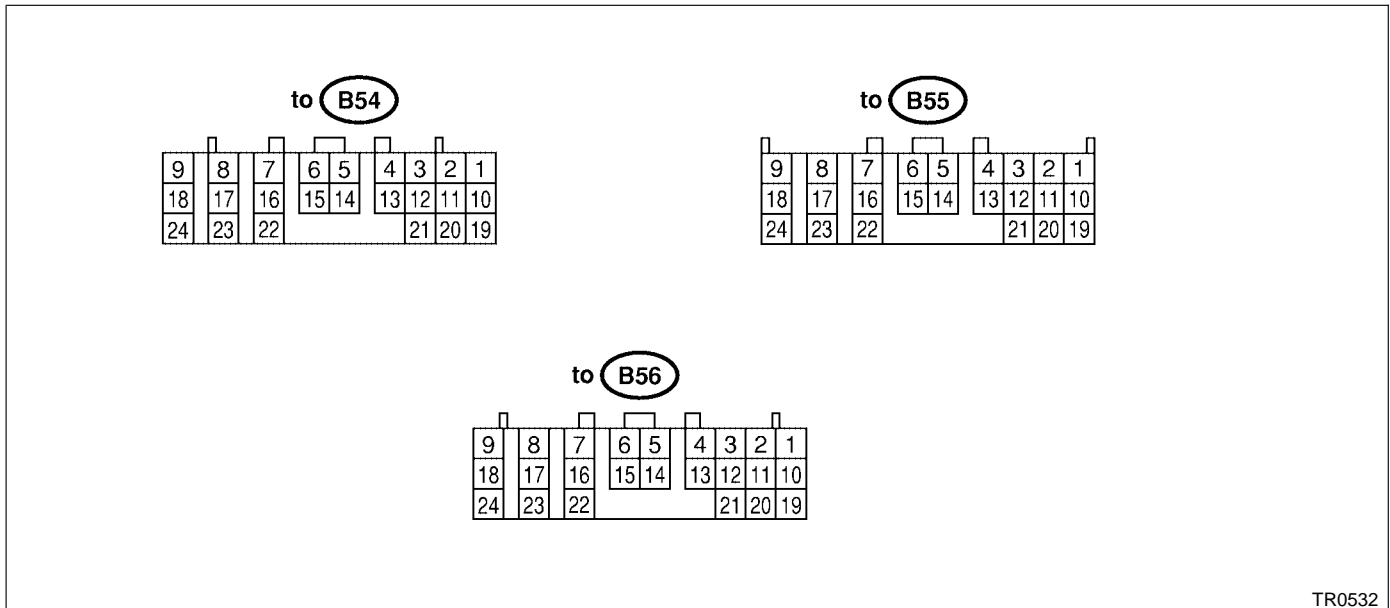

TR0532

Check with ignition switch ON.						
Content	Con- nector No.	Terminal No.	Measuring conditions	Voltage (V)	Resistance to body (ohms)	
Back-up power supply	B56	1	Ignition switch OFF	10 — 16	—	
Ignition power supply	B54	23	Ignition switch ON (with engine OFF)	10 — 16	—	
	B54	24				
Inhibitor switch	"P" range switch	B55	1	Select lever in "P" range	Less than 1	—
				Select lever in any other than "P" range (except "N" range)	More than 8	
	"N" range switch	B55	14	Select lever in "N" range	Less than 1	—
				Select lever in any other than "N" range (except "P" range)	More than 8	
	"R" range switch	B55	3	Select lever in "R" range	Less than 1	—
				Select lever in any other than "R" range	More than 8	
	"D" range switch	B55	4	Select lever in "D" range	Less than 1	—
				Select lever in any other than "D" range	More than 8	
	"3" range switch	B55	5	Select lever in "3" range	Less than 1	—
				Select lever in any other than "3" range	More than 8	
	"2" range switch	B55	6	Select lever in "2" range	Less than 1	—
				Select lever in any other than "2" range	More than 8	
	"1" range switch	B55	7	Select lever in "1" range	Less than 1	—
				Select lever in any other than "1" range	More than 8	
Brake switch	B55	12	Brake pedal depressed.	More than 10.5	—	
			Brake pedal released.	Less than 1		

TRANSMISSION CONTROL MODULE (TCM) I/O SIGNAL

Automatic Transmission (Diagnostics)

Check with ignition switch ON.					
Content	Connector No.	Terminal No.	Measuring conditions	Voltage (V)	Resistance to body (ohms)
Kick-down switch	B55	11	Throttle fully open.	Less than 1	—
			Throttle fully closed.	More than 6.5	
AT OIL TEMP warning light	B56	10	Light ON	Less than 1	—
			Light OFF	More than 9	
Throttle position sensor	B54	3	Throttle fully closed.	0.3 — 0.7	—
			Throttle fully open.	4.0 — 4.6	
Throttle position sensor power supply (with OBD model)	B54	2	Ignition switch ON (With engine OFF)	4.8 — 5.3	—
ATF temperature sensor	B54	11	ATF temperature 20°C (68°F)	1.6 — 2.0	2.1 k — 2.9 k
			ATF temperature 80°C (176°F)	0.4 — 0.9	275 — 375
Rear vehicle speed sensor	B55	24	Vehicle stopped.	0	450 — 650
			Vehicle speed at least 20 km/h (12 MPH)	More than 1 (AC range)	
Front vehicle speed sensor	B55	18	Vehicle stopped.	0	450 — 650
			Vehicle speed at least 20 km/h (12 MPH)	More than 1 (AC range)	
Torque converter turbine speed sensor	B55	8	Engine idling after warm-up. (D range)	0	450 — 650
			Engine idling after warm-up. (N range)	More than 1 (AC range)	
Vehicle speed output signal (Waveform)	B56	17	Vehicle speed at most 10 km/h (6 MPH)	Less than 1 ← → More than 4	—
Engine speed signal	B55	17	Ignition switch ON (with engine OFF)	More than 10.5	—
			Ignition switch ON (with engine ON)	8 — 11	
Cruise set signal	B55	22	When cruise control is set (SET lamp ON)	Less than 1	—
			When cruise control is not set (SET lamp OFF)	More than 6.5	
Torque control signal 1	B56	5	Ignition switch ON (with engine ON)	More than 4	—
Torque control signal 2	B56	14	Ignition switch ON (with engine ON)	More than 4	—
Torque control cut signal	B55	10	Ignition switch ON	8	—
Intake manifold pressure signal (Non-turbo model)	B54	1	Engine idling after warm-up.	1.2 — 1.8	—
Mass air flow signal (Turbo model)	B54	1	Engine idling after warm-up.	0.5 — 1.2	—
Shift solenoid 1	B54	22	1st or 4th gear	More than 9	10 — 16
			2nd or 3rd gear	Less than 1	
Shift solenoid 2	B54	5	1st or 2nd gear	More than 9	10 — 16
			3rd or 4th gear	Less than 1	

TRANSMISSION CONTROL MODULE (TCM) I/O SIGNAL

Automatic Transmission (Diagnostics)

Check with ignition switch ON.					
Content	Con- nector No.	Terminal No.	Measuring conditions	Voltage (V)	Resistance to body (ohms)
Line pressure duty solenoid	B54	9	Ignition switch ON (with engine OFF) Throttle fully closed after warm-up.	1.5 — 4.0	2.0 — 4.5
			Ignition switch ON (with engine OFF) Throttle fully open after warm-up.	Less than 0.5	
Lock-up duty solenoid	B54	7	When lock up occurs.	More than 8.5	10 — 17
			When lock up is released.	Less than 0.5	
Transfer duty solenoid	B54	6	Fuse on FWD switch	More than 8.5	10 — 17
			Fuse removed from FWD switch (with throttle fully open and with select lever in 1st gear).	Less than 0.5	
2-4 brake duty solenoid	B54	18	Throttle fully closed (with engine OFF) after warm-up.	1.5 — 4.0	2.0 — 4.5
			Throttle fully open (with engine OFF) after warm-up.	Less than 0.5	
2-4 brake timing solenoid	B54	16	1st gear	Less than 1	10 — 16
			3rd gear	More than 9	
Low clutch timing solenoid	B54	15	2nd gear	Less than 1	10 — 16
			4th gear	More than 9	
Hold switch	B55	16	Hold switch ON	Less than 1	—
			Hold switch OFF	More than 8	—
Power switch	B55	23	Power switch ON	Less than 1	—
			Power switch OFF	More than 10	—
Power indicator light	B56	11	Light ON	Less than 1	—
			Light OFF	More than 9	—
FWD switch	B55	20	Fuse removed	6 — 9.1	—
			Fuse installed	Less than 1	—
FWD indicator light	B56	2	Fused ON FWD switch	Less than 1	—
			Fuse removed from FWD switch	More than 9	—
ABS signal	B55	21	ABS switch ON	Less than 1	—
			ABS switch OFF	6.5 — 15	—
Sensor ground line 1	B54	20	—	0	Less than 1
Sensor ground line 2	B55	9	—	0	Less than 1
System ground line	B56	19	—	0	Less than 1
	B54	21			
Sensor ground line 3	B54	10	—	0	Less than 1
Sensor ground line 4	B54	19	—	0	Less than 1
AT diagnosis signal (Waveform)	B56	21	Ignition switch ON	Less than 1 ← → More than 4	—
Data link signal (Subaru Select Monitor)	B56	15	—	—	—
		6	—	—	

TRANSMISSION CONTROL MODULE (TCM) I/O SIGNAL

Automatic Transmission (Diagnostics)

B: SCHEMATIC S004506A21

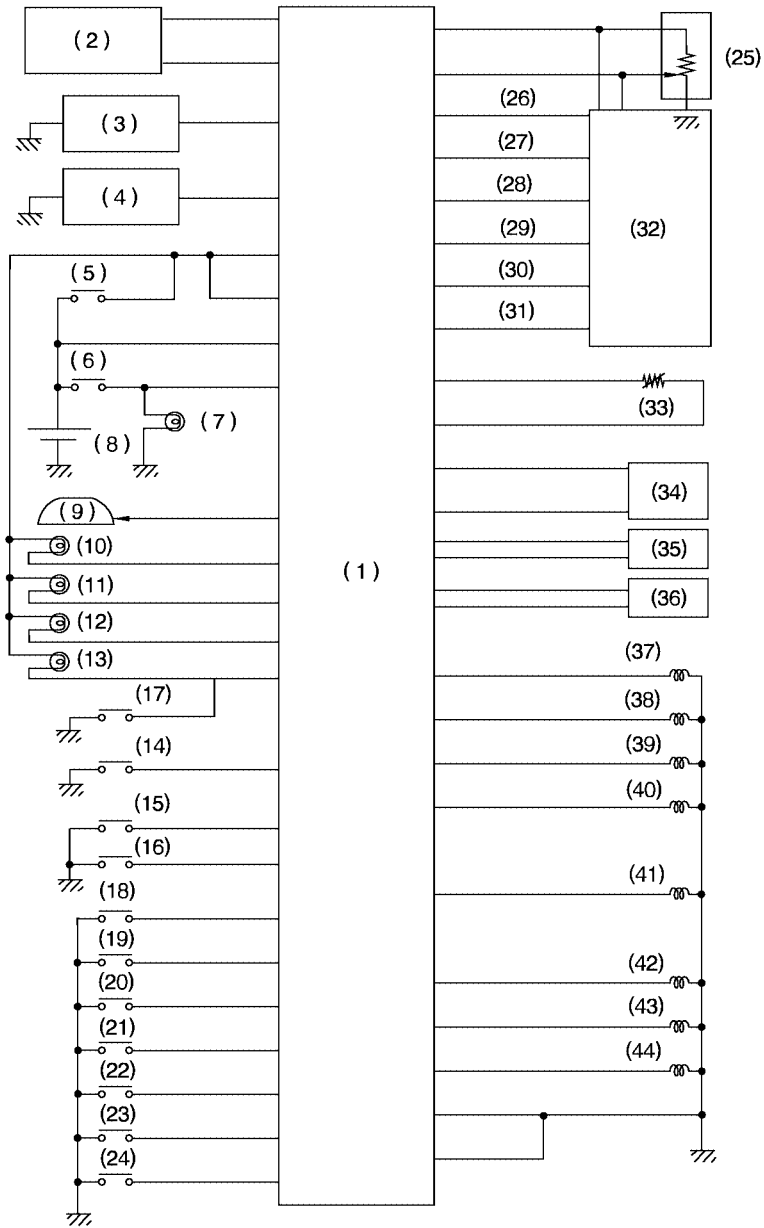

S3M0620

TRANSMISSION CONTROL MODULE (TCM) I/O SIGNAL

Automatic Transmission (Diagnostics)

-
- | | | |
|---|--------------------------------|--|
| (1) Transmission control module | (15) Kick-down switch | (31) AT diagnostic signal (with OBD) |
| (2) Data link connector | (16) Power switch | (32) Engine control module |
| (3) Cruise control module (Non-turbo model) | (17) Hold switch | (33) ATF temperature sensor |
| (4) ABS control module | (18) "P" range switch | (34) Torque converter turbine speed sensor |
| (5) Ignition switch | (19) "R" range switch | (35) Vehicle speed sensor 2 (Front) |
| (6) Brake switch | (20) "N" range switch | (36) Vehicle speed sensor 1 (Rear) |
| (7) Brake light | (21) "D" range switch | (37) Shift solenoid 1 |
| (8) Battery | (22) "3" range switch | (38) Shift solenoid 2 |
| (9) Combination meter (Speedometer circuit) | (23) "2" range switch | (39) 2-4 brake timing solenoid |
| (10) ATF temperature warning light | (24) "1" range switch | (40) Line pressure duty solenoid |
| (11) FWD indicator light | (25) Throttle position sensor | (41) 2-4 brake duty solenoid |
| (12) POWER indicator light | (26) Engine speed signal | (42) Lock-up duty solenoid |
| (13) HOLD indicator light | (27) Torque control cut signal | (43) Low clutch timing solenoid |
| (14) FWD switch | (28) Torque control signal 2 | (44) Transfer duty solenoid |
| | (29) Torque control signal 1 | |
| | (30) AT load signal | |

SUBARU SELECT MONITOR

Automatic Transmission (Diagnostics)

6. Subaru Select Monitor S004503

A: OPERATION S004503A16

1. READ DIAGNOSTIC TROUBLE CODE S004503A1601

1) Prepare Subaru Select Monitor kit.

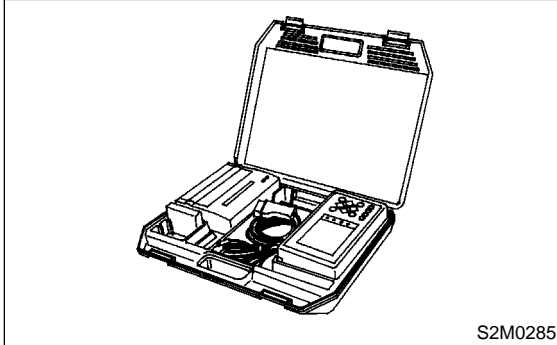

2) Connect diagnosis cable to Subaru Select Monitor.

3) Insert cartridge into Subaru Select Monitor.
<Ref. to AT-7, PREPARATION TOOL, General Description.>

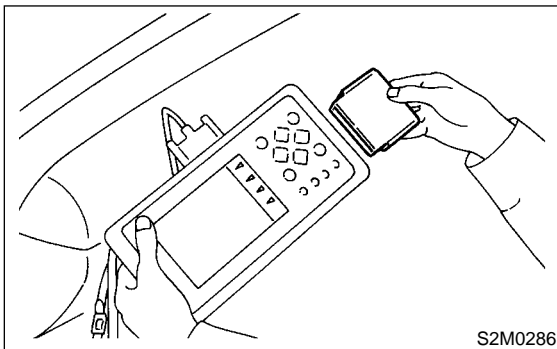

4) Connect Subaru Select Monitor to data link connector.

(1) Data link connector located in the lower portion of the instrument panel (on the driver's side).

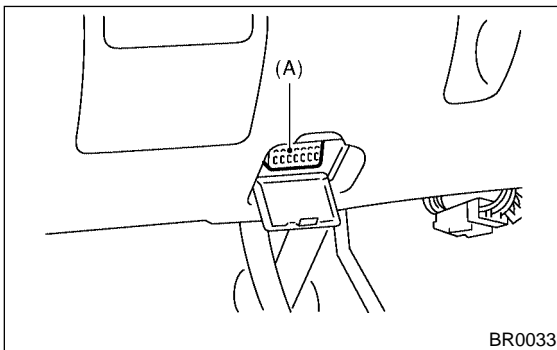

(A) Data link connector

(2) Connect diagnosis cable to data link connector.

CAUTION:

Do not connect scan tools except for Subaru Select Monitor and OBD-II general scan tool.

5) Turn ignition switch to ON (engine OFF) and Subaru Select Monitor switch to ON.

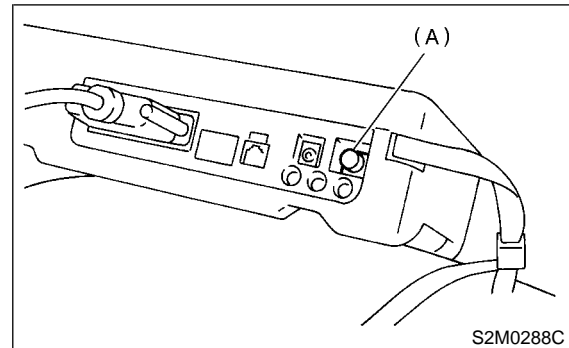

(A) Power switch

6) On the «Main Menu» display screen, select the {Each System Check} and press the [YES] key.

7) On the «System Selection Menu» display screen, select the {Transmission Control System} and press the [YES] key.

8) Press the [YES] key after displayed the information of transmission type.

9) On the «Transmission Diagnosis» display screen, select the {Diagnostic Code(s) Display} and press the [YES] key.

10) On the «Diagnostic Code(s) Display» display screen, select the {Latest Diagnostic Code(s)} or {Memorized Diagnostic Code(s)} and press the [YES] key.

NOTE:

- For detailed operation procedure, refer to the SUBARU SELECT MONITOR OPERATION MANUAL.

- For detailed concerning diagnostic trouble codes, refer to the DIAGNOSTIC TROUBLE CODE LIST. <Ref. to AT-27, List of Diagnostic Trouble Code.>

2. READ CURRENT DATA S004503A1602

1) On the «Main Menu» display screen, select the {Each System Check} and press the [YES] key.

2) On the «System Selection Menu» display screen, select the {Transmission Control System} and press the [YES] key.

3) Press the [YES] key after displayed the information of transmission type.

4) On the «Transmission Diagnosis» display screen, select the {Current Data Display & Save} and press the [YES] key.

5) On the «Data Display Menu» display screen, select the {Data Display} and press the [YES] key.

6) Using the scroll key, move the display screen up or down until the desired data is shown.

SUBARU SELECT MONITOR

Automatic Transmission (Diagnostics)

- A list of the support data is shown in the following table.

Contents	Display	Unit of measure
Battery voltage	Battery Voltage	V
Rear vehicle speed sensor signal	Rear Wheel Speed	km/h or MPH
Front vehicle speed sensor signal	Front Wheel Speed	km/h or MPH
Engine speed signal	Engine Speed	rpm
Automatic transmission fluid temperature signal	ATF Temp.	°C or °F
Throttle position signal	Throttle Sensor Voltage	V
Gear position	Gear Position	—
Line pressure control duty ratio	Line Pressure Duty Ratio	%
Lock up clutch control duty ratio	Lock Up Duty Ratio	%
Transfer clutch control duty ratio	Transfer Duty Ratio	%
Power supply for throttle position sensor	Throttle Sensor Power	V
Torque converter turbine speed signal	Turbine Revolution Speed	rpm
2-4 brake timing pressure control duty ratio	Brake Clutch Duty Ratio	%
Intake manifold pressure sensor voltage	Mani. Pressure Voltage	V
2 wheel drive switch signal	FWD Switch	ON or OFF
Stop lamp switch signal	Stop Light Switch	ON or OFF
Anti lock brake system signal	ABS Signal	ON or OFF
Cruise control system signal	Cruise Control Signal	ON or OFF
Neutral/Parking range signal	N/P Range Signal	ON or OFF
Reverse range signal	R Range Signal	ON or OFF
Drive range signal	D Range Signal	ON or OFF
3rd range signal	3rd Range Signal	ON or OFF
2nd range signal	2nd Range Signal	ON or OFF
1st range signal	1st Range Signal	ON or OFF
Shift control solenoid A	Shift Solenoid #1	ON or OFF
Shift control solenoid B	Shift Solenoid #2	ON or OFF
Torque control output signal #1	Torque Control Signal 1	ON or OFF
Torque control output signal #2	Torque Control Signal 2	ON or OFF
Torque control cut signal	Torque Control Cut Sig.	ON or OFF
2-4 brake timing control solenoid valve	2-4 Brake Timing Sol.	ON or OFF
Low clutch timing control solenoid valve	Low Clutch Timing Sol.	ON or OFF
Automatic transmission diagnosis indicator lamp	Diagnosis Lamp	ON or OFF
Power mode switch signal	Power Mode Switch	ON or OFF
Hold mode switch signal	Hold Mode Switch	ON or OFF
Kick down switch signal	Kick Down Switch	ON or OFF
Automatic transmission fluid temperature lamp	ATF Temperature Lamp	ON or OFF

NOTE:

For detailed operation procedure, refer to the SUBARU SELECT MONITOR OPERATION MANUAL.

3. CLEAR MEMORY MODE S004503A1603

- 1) On the «Main Menu» display screen, select the {2. Each System Check} and press the [YES] key.
- 2) On the «System Selection Menu» display screen, select the {Transmission Control System} and press the [YES] key.
- 3) Press the [YES] key after displayed the information of transmission type.

- 4) On the «Transmission Diagnosis» display screen, select the {Clear Memory} and press the [YES] key.
- 5) When the 'Done' and 'Turn Ignition Switch OFF' are shown on the display screen, turn the Subaru Select Monitor and ignition switch to OFF.

NOTE:

For detailed operation procedure, refer to the SUBARU SELECT MONITOR OPERATION MANUAL.

READ DIAGNOSTIC TROUBLE CODE

Automatic Transmission (Diagnostics)

7. Read Diagnostic Trouble Code S004508

A: OPERATION S004508A16

1. WITHOUT SUBARU SELECT MONITOR S004508A1601

No.	Step	Check	Yes	No
1	PERFORM READ DIAGNOSTIC TROUBLE CODE. 1) Warm-up the engine. 2) Turn ignition switch to OFF. 3) Turn ignition switch to ON. 4) Start the engine. 5) Drive vehicle at speeds greater than 20 km/h (12 MPH). 6) Stop vehicle. 7) Brake pedal depressed and move select lever to 1 range. 8) Turn ignition switch to OFF. 9) Turn ignition switch to ON. 10) Move select lever 2 range. 11) Move select lever 1 range. 12) Move select lever 2 range. 13) Move select lever 3 range. 14) Move select lever D range.	Does indicator light blinks at 4-Hz intervals? NOTE: Blinks every 0.125 (1/8) seconds (until ignition switch is turned OFF).	Repair power supply and ground circuit.<Ref. to AT-32, CHECK POWER SUPPLY AND GROUND LINE, Diagnostic Procedure for Power Indicator Light.>	Go to step 2.
2	CHECK INDICATOR LIGHT.	Does indicator light blinks at 2-Hz intervals? NOTE: Blinks every 0.25 (1/4) seconds (until ignition switch is turned OFF).	AT system is normal.	Go to step 3.
3	CHECK INDICATOR LIGHT.	Is trouble code outputted?	Inspect problem corresponding with trouble code. NOTE: Record all trouble codes.	Go to step 4.
4	CHECK INDICATOR LIGHT.	Does indicator light remains illuminated?	Repair power indicator light circuit <Ref. to AT-28, Diagnostic Procedure for Power Indicator Light.>, or Inspect inhibitor switch, wiring, TCM, etc.	Calling up trouble code again.

READ DIAGNOSTIC TROUBLE CODE

Automatic Transmission (Diagnostics)

The power indicator light flashes the code corresponding to the faulty part.

The long segment (1.2 sec on) indicates a "ten", and the short segment (0.2 sec on) signifies a "one".

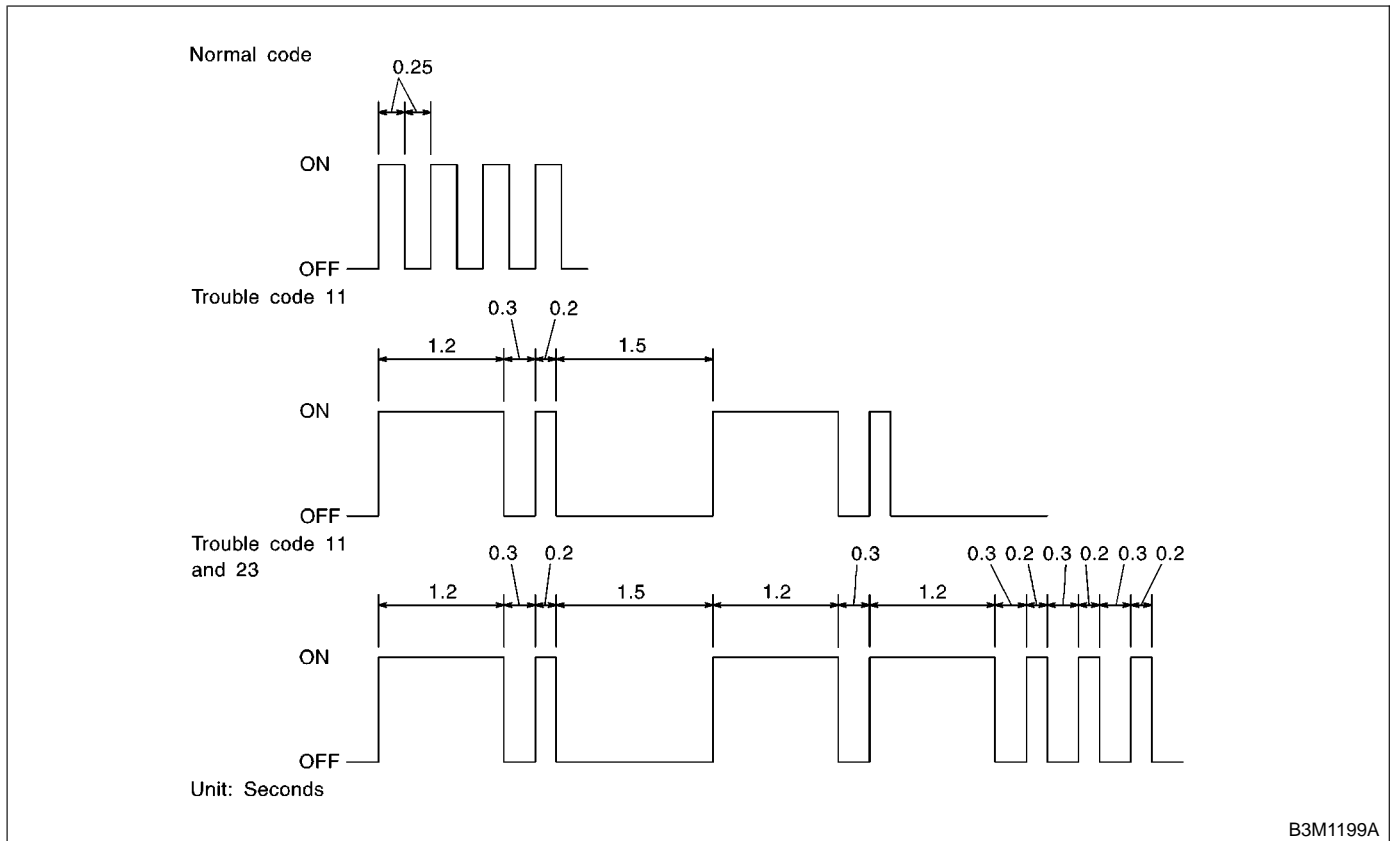

2. WITH SUBARU SELECT MONITOR

S004508A1602

Refer to SUBARU SELECT MONITOR for information about how to obtain and understand trouble codes. <Ref. to AT-20, OPERATION, Subaru Select Monitor.>

8. Inspection Mode S004510

A: OPERATION S004510A16

Raise the vehicle using a garage jack and place on safety stands or drive the vehicle onto free rollers.

WARNING:

- Before raising the vehicle, ensure parking brakes are applied.
- Do not use a pantograph jack in place of a safety stand.
- Secure a rope or wire to the front and rear towing or tie-down hooks to prevent the lateral runoff of front wheels.
- Do not abruptly depress/release clutch pedal or accelerator pedal during works even when engine is operating at low speeds since this may cause vehicle to jump off free rollers.
- In order to prevent the vehicle from slipping due to vibration, do not place any wooden blocks or similar items between the safety stands and the vehicle.
- Since the rear wheels will also rotate, do not place anything near them. Also, make sure that nobody goes in front of the vehicle.

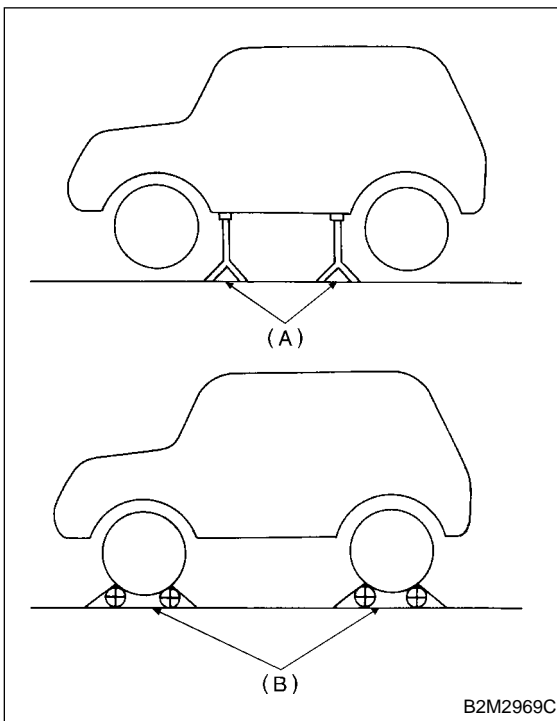

- (A) Safety stand
(B) Free rollers

9. Clear Memory Mode S004513

A: OPERATION S004513A16

1. WITHOUT SUBARU SELECT MONITOR

S004513A1602

Current trouble codes shown on the display are cleared by turning the ignition switch OFF after conducting on-board diagnostics operation. Previous trouble codes, however, cannot be cleared since they are stored in the TCM memory which is operating on the back-up power supply. These trouble codes can be cleared by removing the specified fuse (located under the light or left lower position of the instrument panel).

CLEAR MEMORY:

Removal of No. 4 fuse (for at least one minute)

- The No. 4 fuse is located in the line to the memory back-up power supply of the TCM. Removal of this fuse clears the previous trouble codes stored in the TCM memory.
- Be sure to remove the No. 4 fuse for at least the specified length of time. Otherwise, trouble codes may not be cleared.

2. WITH SUBARU SELECT MONITOR

S004513A1601

Refer to SUBARU SELECT MONITOR for information about how to clear trouble codes.
<Ref. to AT-21, CLEAR MEMORY MODE, OPERATION, Subaru Select Monitor.>

POWER INDICATOR LIGHT DISPLAY

Automatic Transmission (Diagnostics)

10. Power Indicator Light Display

S004729

A: INSPECTION

S004729A10

When any on-board diagnostics item is malfunctioning, the display on the power indicator light blinks from the time the malfunction is detected after starting the engine until the ignition switch is turned OFF. The malfunctioning part or

unit can be determined by a trouble code during on-board diagnostics operation. Problems which occurred previously can also be identified through the memory function. If the power indicator does not show a problem (although a problem is occurring), the problem can be determined by checking the performance characteristics of each sensor using the select monitor. Indicator signal is as shown in the figure.

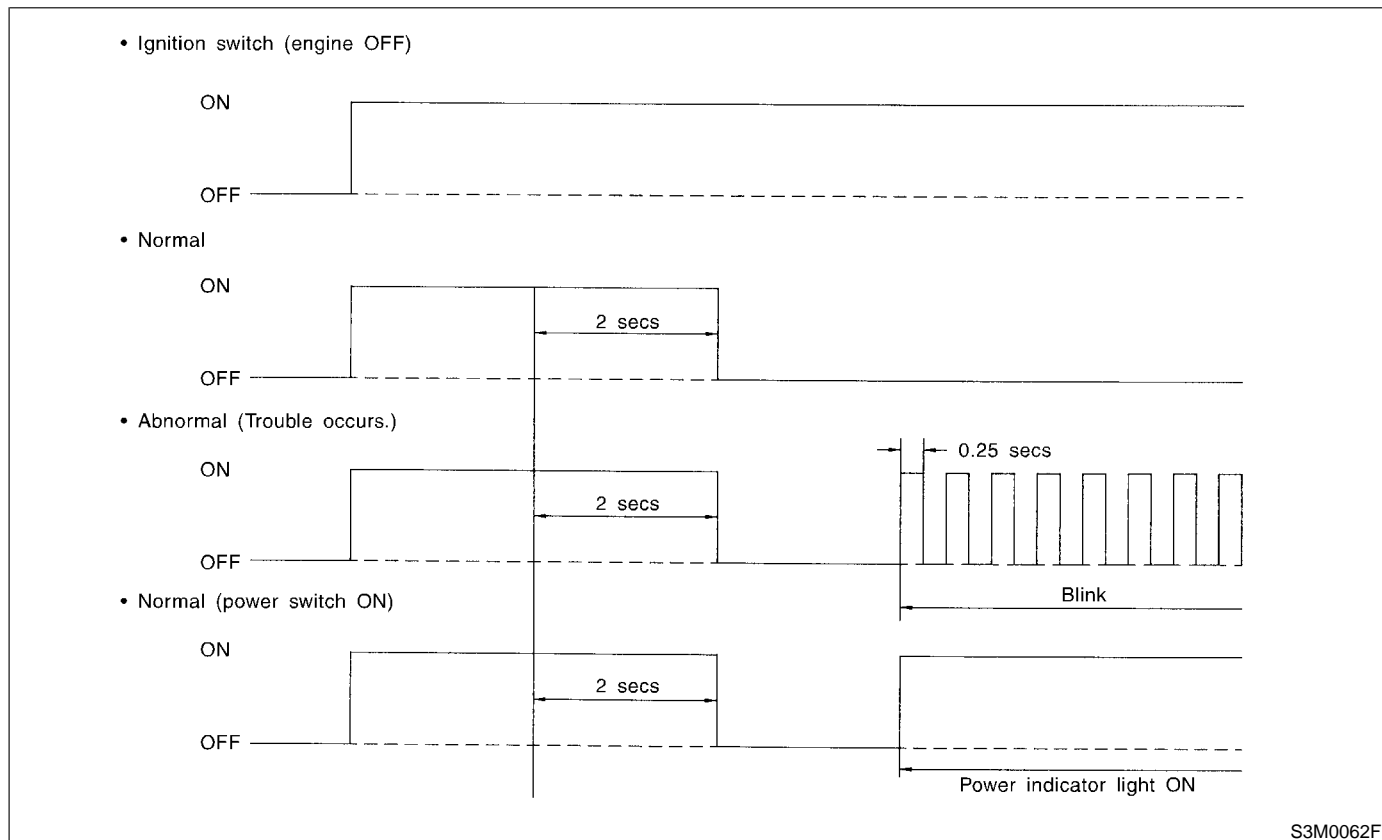

LIST OF DIAGNOSTIC TROUBLE CODE

Automatic Transmission (Diagnostics)

11. List of Diagnostic Trouble Code S004511

A: LIST S004511A12

Trouble code	Item	Content of diagnosis	Index
11	Engine speed signal	Detects open or shorted input signal circuit.	<Ref. to AT-42, TROUBLE CODE 11 — ENGINE SPEED SIGNAL —, Diagnostic Procedure with Trouble Code.>
23	Mass air flow signal (Turbo model)	Detects open or shorted input signal circuit.	<Ref. to AT-44, TROUBLE CODE 23 — MASS AIR FLOW SIGNAL —, Diagnostic Procedure with Trouble Code.>
27	ATF temperature sensor	Detects open or shorted input signal circuit.	<Ref. to AT-46, TROUBLE CODE 27 — ATF TEMPERATURE SENSOR —, Diagnostic Procedure with Trouble Code.>
31	Throttle position sensor	Detects open or shorted input signal circuit.	<Ref. to AT-50, TROUBLE CODE 31 — THROTTLE POSITION SENSOR —, Diagnostic Procedure with Trouble Code.>
33	Front vehicle speed sensor	Detects open or shorted input signal circuit.	<Ref. to AT-58, TROUBLE CODE 33 — FRONT VEHICLE SPEED SENSOR —, Diagnostic Procedure with Trouble Code.>
36	Torque converter turbine speed sensor	Detects open or shorted input signal circuit.	<Ref. to AT-64, TROUBLE CODE 36 — TORQUE CONVERTER TURBINE SPEED SENSOR —, Diagnostic Procedure with Trouble Code.>
38	Torque control signal	Detects open or shorted input signal circuit.	<Ref. to AT-68, TROUBLE CODE 38 — TORQUE CONTROL SIGNAL —, Diagnostic Procedure with Trouble Code.>
45	Intake manifold pressure signal (Non-turbo model)	Detects open or shorted input signal circuit.	<Ref. to AT-70, TROUBLE CODE 45 — INTAKE MANIFOLD PRESSURE SIGNAL —, Diagnostic Procedure with Trouble Code.>
71	Shift solenoid 1	Detects open or shorted output signal circuit.	<Ref. to AT-72, TROUBLE CODE 71 — SHIFT SOLENOID 1 —, Diagnostic Procedure with Trouble Code.>
72	Shift solenoid 2	Detects open or shorted output signal circuit.	<Ref. to AT-76, TROUBLE CODE 72 — SHIFT SOLENOID 2 —, Diagnostic Procedure with Trouble Code.>
73	Low clutch timing solenoid	Detects open or shorted output signal circuit.	<Ref. to AT-80, TROUBLE CODE 73 — LOW CLUTCH TIMING SOLENOID —, Diagnostic Procedure with Trouble Code.>
74	2-4 brake timing solenoid	Detects open or shorted output signal circuit.	<Ref. to AT-84, TROUBLE CODE 74 — 2-4 BRAKE TIMING SOLENOID —, Diagnostic Procedure with Trouble Code.>
75	Line pressure duty solenoid	Detects open or shorted output signal circuit.	<Ref. to AT-88, TROUBLE CODE 75 — LINE PRESSURE DUTY SOLENOID —, Diagnostic Procedure with Trouble Code.>
76	2-4 brake duty solenoid	Detects open or shorted output signal circuit.	<Ref. to AT-92, TROUBLE CODE 76 — 2-4 BRAKE DUTY SOLENOID —, Diagnostic Procedure with Trouble Code.>
77	Lock-up duty solenoid	Detects open or shorted output signal circuit.	<Ref. to AT-96, TROUBLE CODE 77 — LOCK-UP DUTY SOLENOID —, Diagnostic Procedure with Trouble Code.>
79	Transfer duty solenoid	Detects open or shorted output signal circuit.	<Ref. to AT-100, TROUBLE CODE 79 — TRANSFER DUTY SOLENOID —, Diagnostic Procedure with Trouble Code.>
93	Rear vehicle speed sensor	Detects open or shorted input signal circuit.	<Ref. to AT-104, TROUBLE CODE 93 — REAR VEHICLE SPEED SENSOR —, Diagnostic Procedure with Trouble Code.>

DIAGNOSTIC PROCEDURE FOR POWER INDICATOR LIGHT

Automatic Transmission (Diagnostics)

12. Diagnostic Procedure for Power Indicator Light S004730

A: POWER INDICATOR LIGHT DOES NOT COME ON OR GO OFF S004730G75

DIAGNOSIS:

The POWER Indicator light circuit is open or shorted.

TROUBLE SYMPTOM:

- When ignition switch is turned to ON (engine OFF), POWER indicator light does not illuminate.
- When on-board diagnostics is performed, POWER indicator light remains illuminated.

DIAGNOSTIC PROCEDURE FOR POWER INDICATOR LIGHT

Automatic Transmission (Diagnostics)

WIRING DIAGRAM:

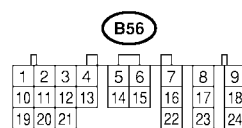
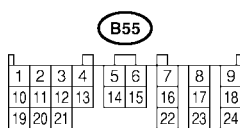
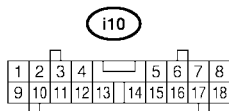
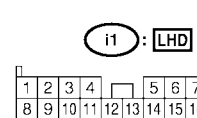
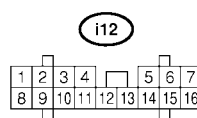
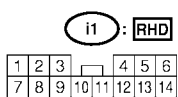
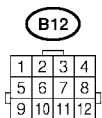
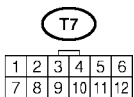
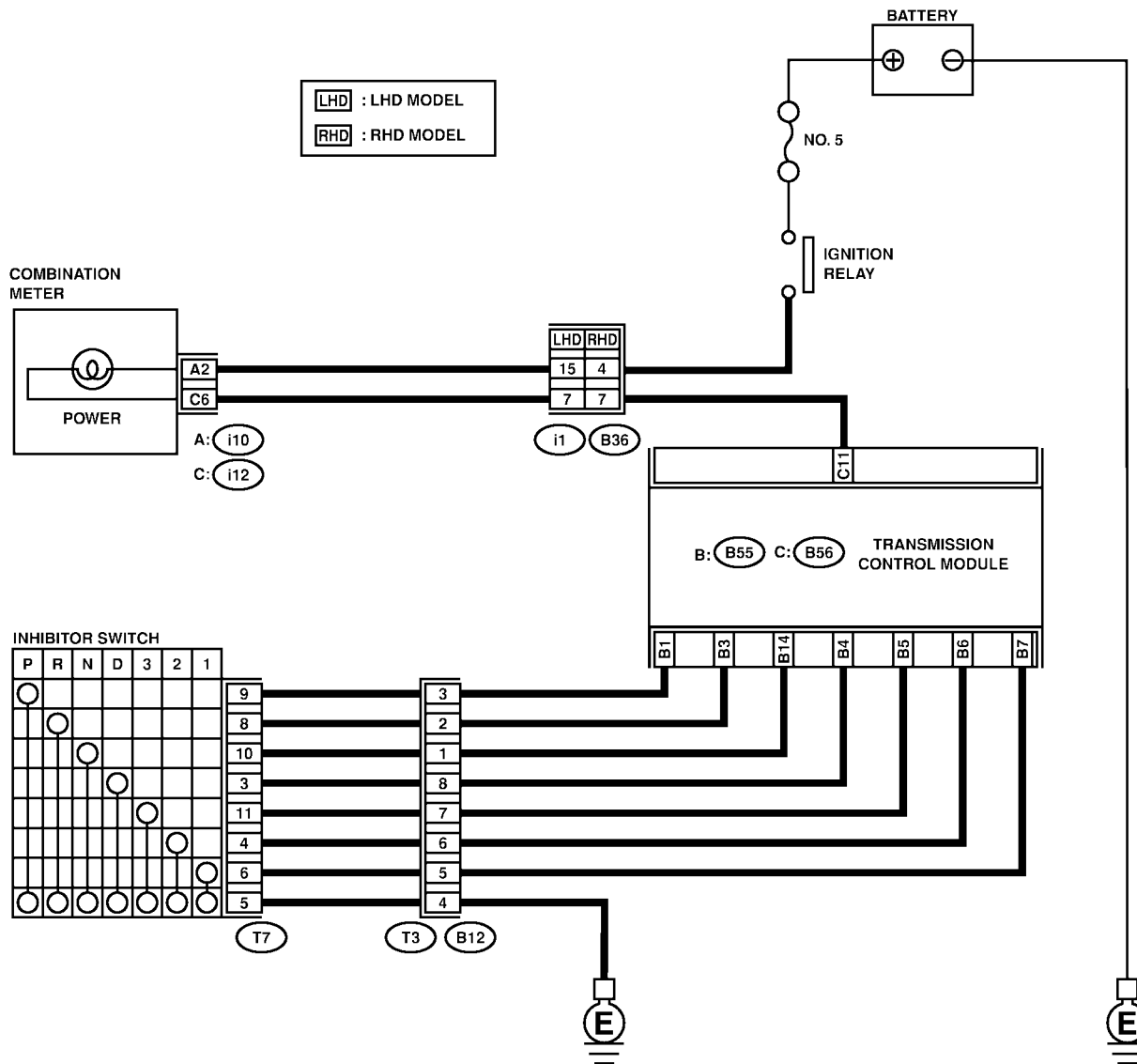

S3M0621

No.	Step	Check	Yes	No
1	CHECK POWER INDICATOR LIGHT. Turn ignition switch to ON (engine OFF).	Does POWER indicator light illuminate?	Go to step 3.	Go to step 2.

DIAGNOSTIC PROCEDURE FOR POWER INDICATOR LIGHT

Automatic Transmission (Diagnostics)

No.	Step	Check	Yes	No
2	CHECK POWER INDICATOR LIGHT. 1) Turn ignition switch to OFF. 2) Remove combination meter. 3) Remove POWER indicator light bulb from combination meter.	Is POWER indicator light bulb OK?	Go to step 4.	Replace POWER indicator light bulb.
3	CHECK POWER INDICATOR LIGHT. Perform "Read Diagnostic Trouble Code". <Ref. to AT-22, WITHOUT SUBARU SELECT MONITOR OPERATION, Read Diagnostic Trouble Code.>	Does POWER indicator light blink?	A temporary poor contact of the connector or harness may be the cause. Repair harness or connector in TCM, inhibitor switch and combination meter.	Go to step 9.
4	CHECK FUSE (No. 5). Remove fuse (No. 5).	Is the fuse (No. 5) blown out?	Replace fuse (No. 5). If replaced fuse (No. 5) is blown out easily, repair short circuit in harness between fuse (No. 5) and combination meter.	Go to step 5.
5	CHECK HARNESS CONNECTOR BETWEEN COMBINATION METER AND IGNITION RELAY. 1) Turn ignition switch to ON (engine OFF). 2) Measure voltage between combination meter connector and chassis ground. <i>Connector & terminal</i> <i>(i10) No. 2 (+) — Chassis ground (-):</i>	Is voltage more than 9 V?	Go to step 6.	Repair open or short circuit in harness between combination meter and battery.
6	CHECK COMBINATION METER. Measure voltage between combination meter connector and chassis ground. <i>Connector & terminal</i> <i>(i12) No. 6 (+) — Chassis ground (-):</i>	Is voltage less than 1 V?	Go to step 7.	Repair combination meter. <Ref. to IDI-15, Combination Meter Assembly.>
7	CHECK OPEN CIRCUIT OF HARNESS. 1) Turn ignition switch to OFF. 2) Disconnect TCM and combination meter connector. 3) Measure resistance of harness between combination meter. <i>Connector & terminal</i> <i>(B56) No. 11 — (i12) No. 6:</i>	Is the resistance less than 1 Ω ?	Go to step 8.	Repair open circuit in harness between TCM and combination meter, and poor contact in coupling connector.
8	CHECK INPUT SIGNAL FOR TCM. 1) Connect connector to TCM and combination meter. 2) Turn ignition switch to ON (engine OFF). 3) Measure voltage between TCM connector and chassis ground. <i>Connector & terminal</i> <i>(B56) No. 11 (+) — Chassis ground (-):</i>	Is the voltage less than 1 V?	Even if POWER indicator lights up, the circuit has returned to a normal condition at this time. A temporary poor contact of the connector or harness may be the cause. Repair harness or connector in TCM.	Replace TCM. <Ref. to AT-48, Transmission Control Module (TCM).>
9	CHECK SUBARU SELECT MONITOR.	Do you have SUBARU SELECT MONITOR?	Go to step 10.	Go to step 11.

DIAGNOSTIC PROCEDURE FOR POWER INDICATOR LIGHT

Automatic Transmission (Diagnostics)

No.	Step	Check	Yes	No
10	CHECK INHIBITOR SWITCH. 1) Connect Subaru Select Monitor to data link connector. 2) Turn ignition switch to ON. 3) Subaru Select Monitor to ON. 4) Read data of range switch using Subaru Select Monitor. ● Range switch is indicated in ON ⇔ OFF.	When each range is selected, does LED of Subaru Select Monitor light up?	Go to step 11.	Check inhibitor switch circuit. <Ref. to AT-122, CHECK INHIBITOR SWITCH., Diagnostic Procedure for No-trouble Code.>
11	CHECK SHORT CIRCUIT OF HARNESS. 1) Disconnect connector from TCM. 2) Remove combination meter. 3) Disconnect connector from combination meter. 4) Measure resistance of harness connector between TCM and chassis ground. Connector & terminal/specified resistance (B56) No. 11 (+) — Chassis ground (-):	Is the resistance less than 1 MΩ?	Replace TCM. <Ref. to AT-48, Transmission Control Module (TCM).>	Repair short circuit in harness between combination meter connector and TCM connector.

DIAGNOSTIC PROCEDURE FOR POWER INDICATOR LIGHT

Automatic Transmission (Diagnostics)

B: CHECK POWER SUPPLY AND GROUND LINE

S004730G86

WIRING DIAGRAM:
WITHOUT OBD MODEL

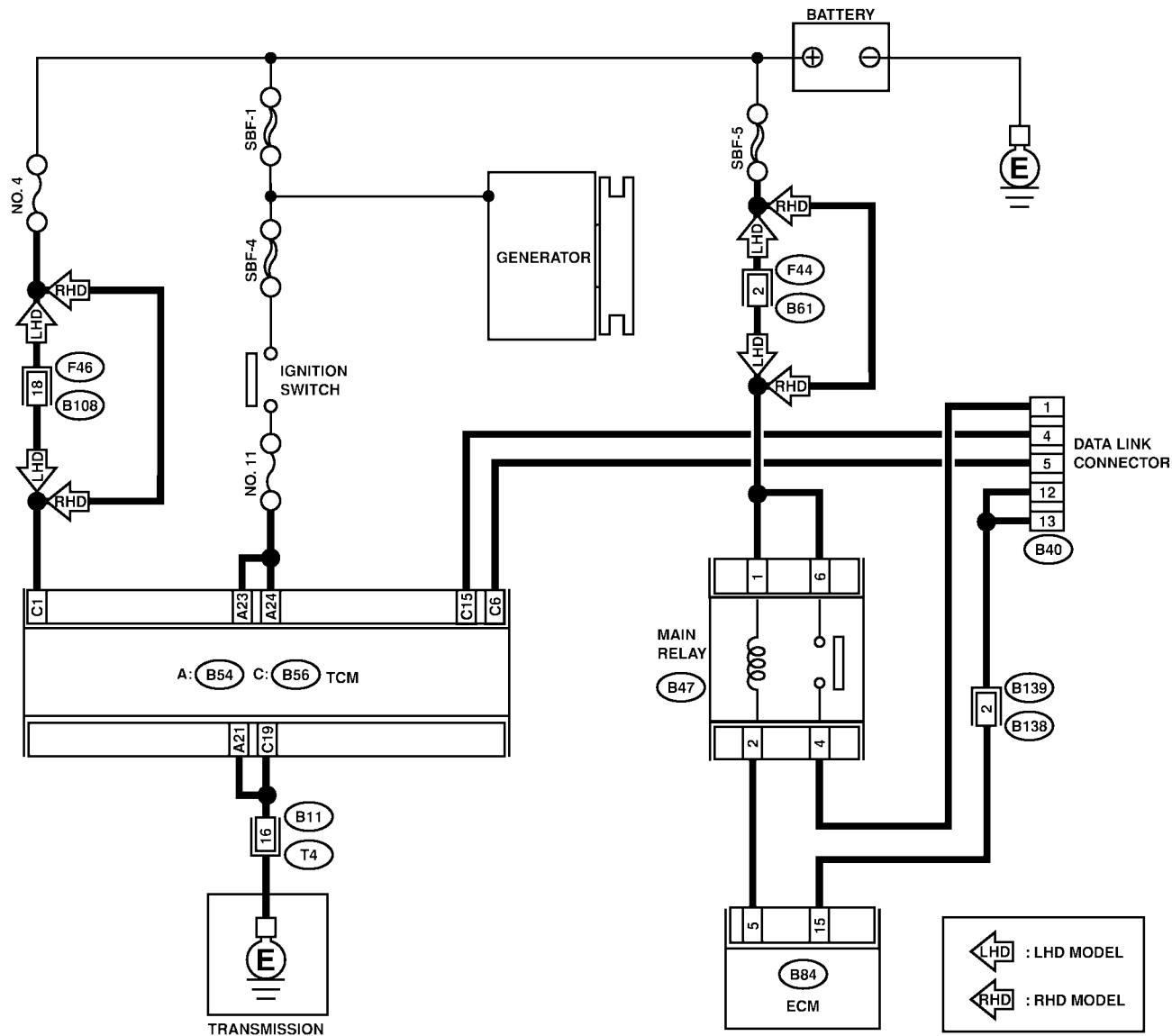

B138



B47



B61



B108



B40



B11



B54



B56



B84



DIAGNOSTIC PROCEDURE FOR POWER INDICATOR LIGHT

Automatic Transmission (Diagnostics)

WITH OBD MODEL

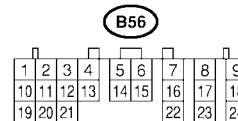
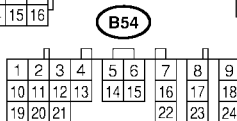
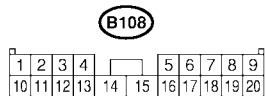
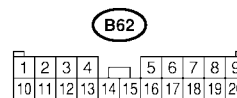
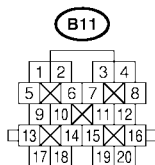
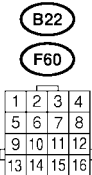
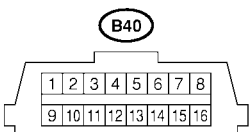
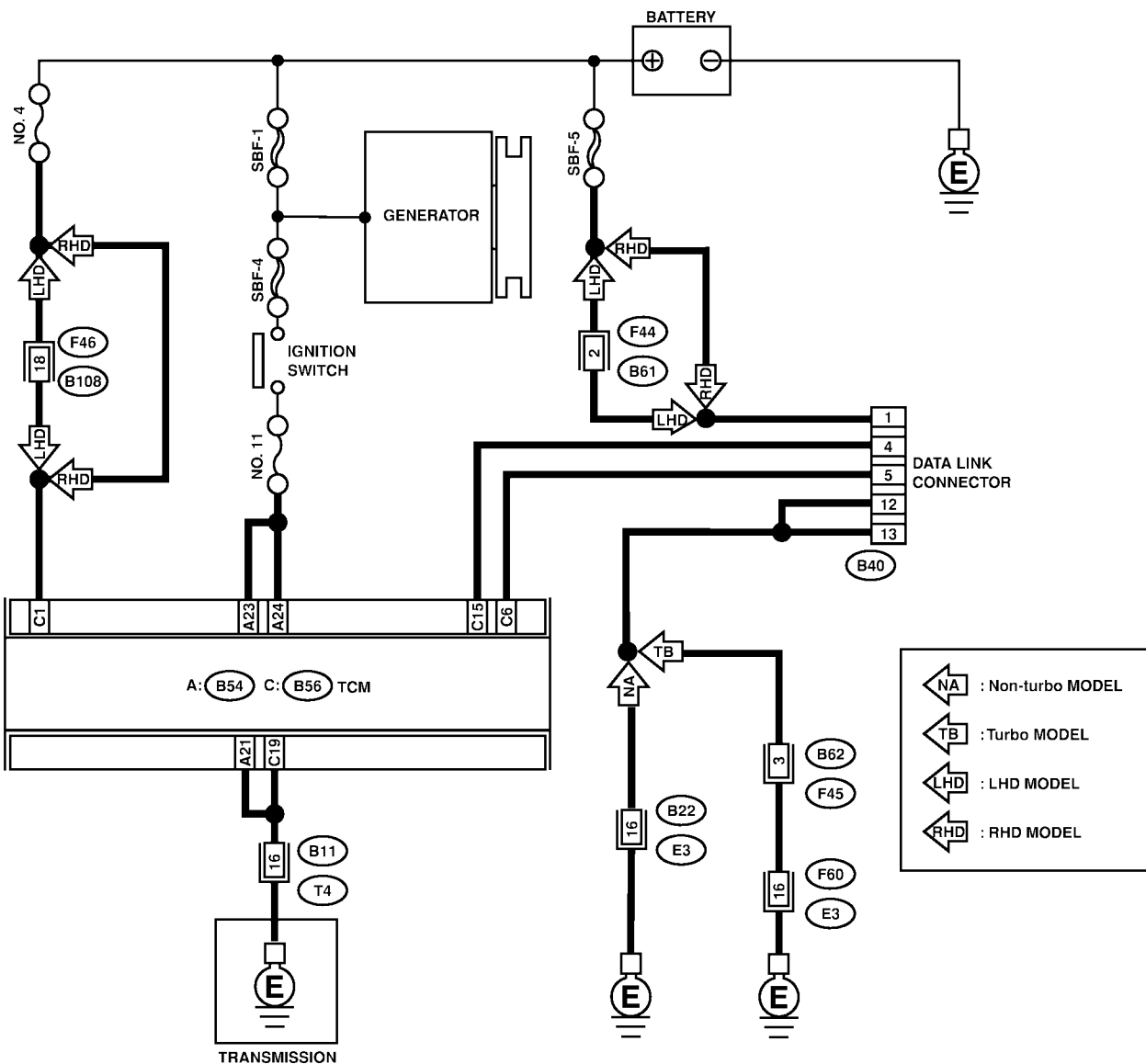

DIAGNOSTIC PROCEDURE FOR POWER INDICATOR LIGHT

Automatic Transmission (Diagnostics)

No.	Step	Check	Yes	No
1	CHECK IGNITION SWITCH.	Is ignition switch ON?	Go to step 2.	Turn ignition switch ON.
2	CHECK GENERATOR. 1) Start the engine. 2) Idle the engine. 3) Measure voltage between generator and chassis ground. Terminal Generator B terminal (+) — Chassis ground (-):	Is the voltage between 10 and 15 V?	Go to step 3.	Repair generator. <Ref. to SC-12, Generator.>
3	CHECK BATTERY TERMINAL. Turn ignition switch to OFF.	Is there poor contact at battery terminal?	Repair battery terminal.	Go to step 4.
4	CHECK POWER SUPPLY OF TCM. 1) Disconnect connector from TCM. 2) Turn ignition switch to ON. 3) Measure voltage between TCM connector and chassis ground. Connector & terminal (B56) No. 1 (+) — Chassis ground (-):	Is the voltage between 10 and 15 V?	Go to step 6.	Go to step 5.
5	CHECK FUSE (NO. 4). Remove fuse (No. 4).	Is the fuse (No. 4) blown out?	Replace fuse (No. 4). If replaced fuse (No. 4) has blown out easily, repair short circuit in harness between fuse (No. 4) and TCM.	Repair open circuit in harness between fuse (No. 4) and TCM, or fuse (No. 4) and battery, and poor contact in coupling connector.
6	CHECK IGNITION POWER SUPPLY CIRCUIT. 1) Turn ignition switch to ON (engine OFF). 2) Measure ignition power supply voltage between TCM connector and chassis ground. Connector & terminal (B54) No. 23 (+) — Chassis ground (-): (B54) No. 24 (+) — Chassis ground (-):	Is the voltage more than 10 V?	Go to step 8.	Go to step 7.
7	CHECK FUSE (NO. 11). Remove fuse (No. 11).	Is the fuse (No. 11) blown out?	Replace fuse (No. 11). If replaced fuse (No. 11) has blown out easily, repair short circuit in harness between fuse (No. 11) and TCM.	Repair open circuit in harness between fuse (No. 11) and TCM, or fuse (No. 11) and battery, and poor contact in coupling connector.
8	CHECK HARNESS CONNECTOR BETWEEN TCM AND TRANSMISSION. 1) Turn ignition switch to OFF. 2) Disconnect connector from TCM and transmission. 3) Measure resistance of harness between TCM and transmission connector. Connector & terminal (B56) No. 19 — (B11) No. 16 (B54) No. 21 — (B11) No. 16	Is the resistance less than 1 Ω?	Go to step 9.	Repair open circuit in harness between TCM and transmission harness connector, and poor contact in coupling connector.

DIAGNOSTIC PROCEDURE FOR POWER INDICATOR LIGHT

Automatic Transmission (Diagnostics)

No.	Step	Check	Yes	No
9	CHECK HARNESS CONNECTOR BETWEEN TRANSMISSION AND TRANSMISSION GROUND. Measure resistance of harness between transmission and transmission ground. Connector & terminal (T4) No. 16 — Transmission ground:	Is the resistance less than 1 Ω ?	Go to step 10.	Repair open circuit in harness between transmission and transmission ground.
10	CHECK POOR CONTACT IN CONNECTORS.	Is there poor contact in control module power supply and ground line?	Repair connector.	Replace TCM. <Ref. to AT-48, Transmission Control Module (TCM).>

DIAGNOSTIC PROCEDURE FOR SELECT MONITOR COMMUNICATION

Automatic Transmission (Diagnostics)

13. Diagnostic Procedure for Select Monitor Communication S004782

A: COMMUNICATION FOR INITIALIZING IMPOSSIBLE S004782E34

DIAGNOSIS:

- Faulty harness connector

TROUBLE SYMPTOM:

- Select monitor communication failure

DIAGNOSTIC PROCEDURE FOR SELECT MONITOR COMMUNICATION

Automatic Transmission (Diagnostics)

WIRING DIAGRAM: WITHOUT OBD

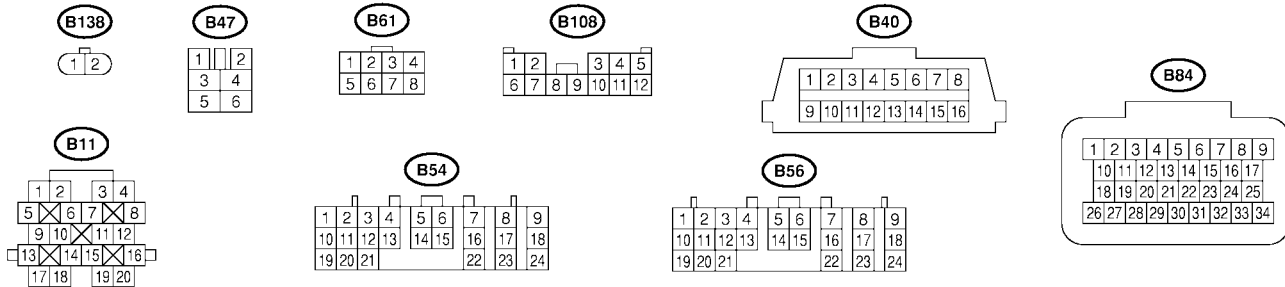
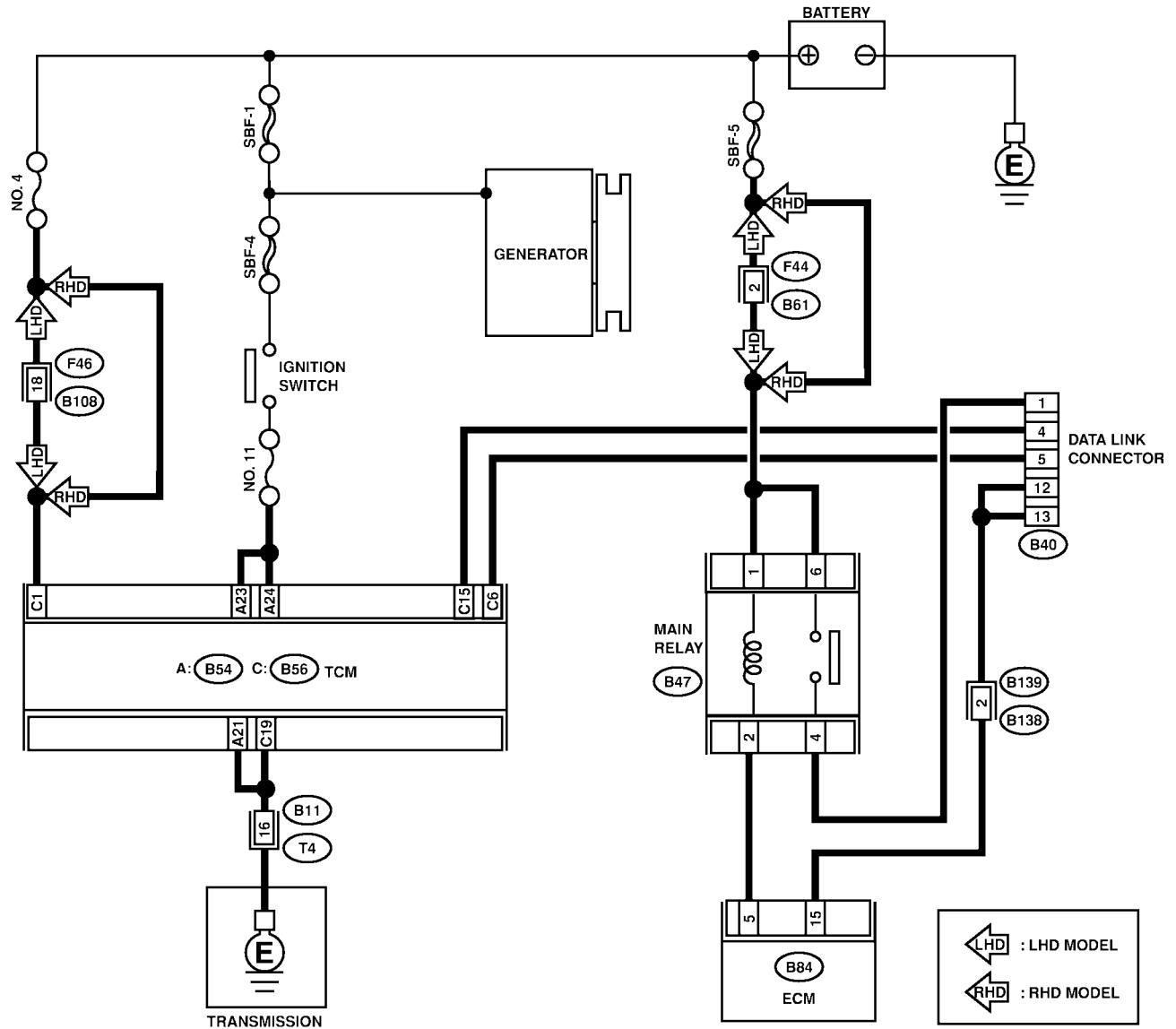

S3M0623

DIAGNOSTIC PROCEDURE FOR SELECT MONITOR COMMUNICATION

Automatic Transmission (Diagnostics)

WITH OBD

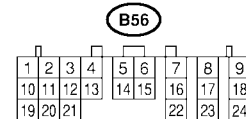
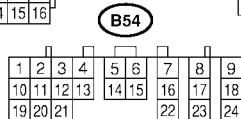
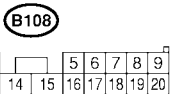
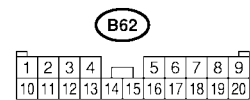
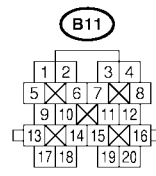
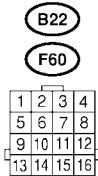
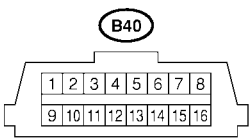
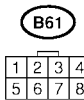
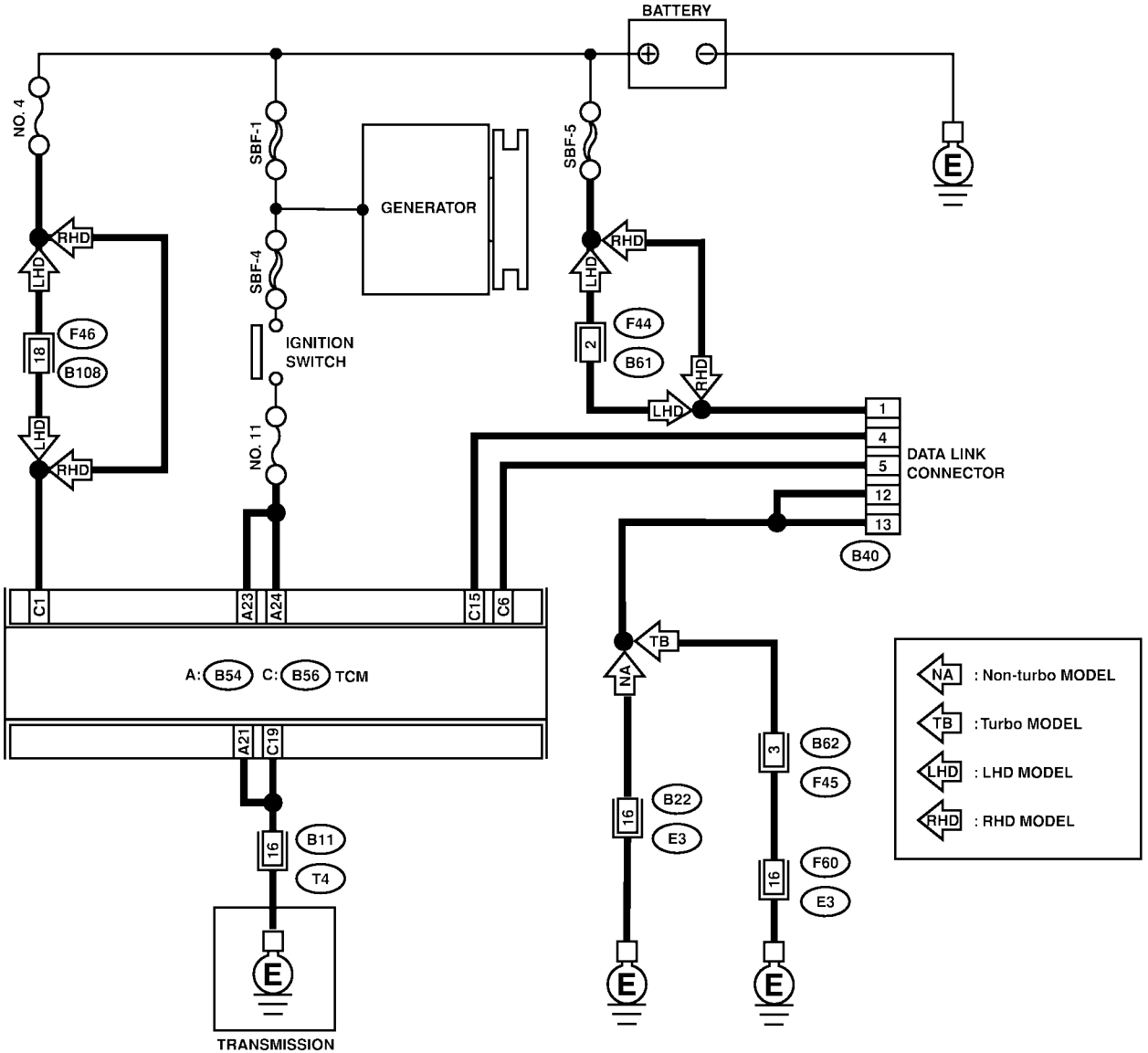

S3M0622

DIAGNOSTIC PROCEDURE FOR SELECT MONITOR COMMUNICATION

Automatic Transmission (Diagnostics)

No.	Step	Check	Yes	No
1	CHECK THE VEHICLE.	Is the target vehicle without OBD?	Go to step 2.	Go to step 10.
2	CHECK MAIN RELAY. 1) Turn ignition switch to OFF. 2) Remove main relay. 3) Connect battery to main relay terminals No. 2 (+) and No. 1 (-). 4) Measure resistance between main relay terminal. Terminal No. 4 — No. 6	Is the resistance less than 10 Ω?	Go to step 3.	Replace main relay.
3	CHECK GROUND CIRCUIT OF ECM. <Ref. to AT-50, TROUBLE CODE 31 — THROTTLE POSITION SENSOR —, Diagnostic Procedure with Trouble Code.>	Is there any trouble?	Repair ground terminal and/or ground circuit of ECM.	Go to step 4.
4	CHECK HARNESS BETWEEN ECM AND MAIN RELAY. 1) Remove main relay connector. 2) Measure voltage between main relay and chassis ground. Connector & terminal (B47) No. 1 — Chassis ground:	Is the voltage more than 10 V?	Go to step 5.	Repair short circuit in harness between battery and main relay connector.
5	CHECK INPUT VOLTAGE TO ECM. 1) Install main relay. 2) Disconnect ECM connector. 3) Measure voltage between ECM connector and chassis ground. Connector & terminal (B84) No. 5 (+) — Chassis ground (-):	Is the voltage more than 10 V?	Go to step 6.	Repair open or short circuit in harness between ECM and main relay connector, then replace ECM.
6	CHECK INPUT VOLTAGE TO SUBARU SELECT MONITOR. 1) Connect main relay connector. 2) Turn ignition switch to ON. 3) Measure voltage between data link connector and chassis ground. Connector & terminal (B40) No. 1 (+) — Chassis ground (-):	Is the voltage more than 10 V?	Go to step 7.	Repair harness and connector between data link connector and battery.
7	CHECK SUBARU SELECT MONITOR GROUND CIRCUIT. 1) Turn ignition switch to OFF. 2) Disconnect ECM connector. 3) Measure resistance between data link connector and chassis ground. Connector & terminal (B40) No. 12 — Chassis ground: (B40) No. 13 — Chassis ground:	Is the resistance more than 1 MΩ?	Go to step 8.	Repair harness and connector between data link connector and ECM connector.
8	CHECK HARNESS BETWEEN BATTERY AND MAIN RELAY. 1) Connect ECM connector. 2) Measure resistance of harness between data link connector and chassis ground. Connector & terminal (B40) No. 12 — Chassis ground: (B40) No. 13 — Chassis ground:	Is the resistance less than 1 Ω?	Go to step 9.	Replace ECM.

DIAGNOSTIC PROCEDURE FOR SELECT MONITOR COMMUNICATION

Automatic Transmission (Diagnostics)

No.	Step	Check	Yes	No
9	<p>CHECK SUBARU SELECT MONITOR GROUND CIRCUIT. Measure resistance between data link connector and ECM connector. Connector & terminal (B40) No. 12 — (B84) No. 15: (B40) No. 13 — (B84) No. 15:</p>	Is the resistance less than 1 Ω ?	Go to step 12.	Repair harness and connector between data link connector and ECM connector, or replace ECM.
10	<p>CHECK SUBARU SELECT MONITOR POWER SUPPLY CIRCUIT. Measure voltage between data link connector and chassis ground. Connector & terminal (B40) No. 1 — Chassis ground:</p>	Is the voltage more than 10 V?	Go to step 11.	Repair harness and connector between battery and data link connector, and poor contact in coupling connector.
11	<p>CHECK SUBARU SELECT MONITOR GROUND CIRCUIT. Measure resistance of harness between data link connector and chassis ground. Connector & terminal (B40) No. 12 — Chassis ground: (B40) No. 13 — Chassis ground:</p>	Is the resistance less than 1 Ω ?	Go to step 12.	Repair open circuit in harness between data link connector and ground terminal, and poor contact in coupling connector.
12	<p>CHECK COMMUNICATION OF SELECT MONITOR. 1) Connect ECM connector (Vehicle without OBD) 2) Turn ignition switch to ON. 3) Using the select monitor, check whether communication to other systems (such as engine, ABS etc.) can be executed normally.</p>	Are the name and year of the system displayed on the select monitor?	Go to step 17.	Go to step 13.
13	<p>CHECK COMMUNICATION OF SELECT MONITOR. 1) Turn ignition switch to OFF. 2) Disconnect TCM connector. 3) Check whether communication to other systems (such as ABS etc.) can be executed normally.</p>	Are the name and year of the system displayed on the select monitor?	Go to step 19.	Go to step 14.
14	<p>CHECK COMMUNICATION OF SELECT MONITOR. 1) Turn ignition switch to OFF. 2) Connect TCM connector. 3) Disconnect ECM connector. 4) Check whether communication to other systems (such as ABS etc.) can be executed normally.</p>	Are the name and year of the system displayed on the select monitor?	Inspect ECM.	Go to step 15.
15	<p>CHECK COMMUNICATION OF SELECT MONITOR. 1) Turn ignition switch to OFF. 2) Connect ECM connector. 3) Disconnect ABSCM&H/U connector. 4) Check whether communication to other systems (such as engine etc.) can be executed normally.</p>	Are the name and year of the system displayed on the select monitor?	Inspect ABSCM&H/U.	Go to step 16.

DIAGNOSTIC PROCEDURE FOR SELECT MONITOR COMMUNICATION

Automatic Transmission (Diagnostics)

No.	Step	Check	Yes	No
16	<p>CHECK COMMUNICATION OF SELECT MONITOR.</p> <p>1) Turn ignition switch to OFF. 2) Connect ABSCM&H/U module connector. 3) Disconnect cruise control module connector. 4) Check whether communication to other systems (such as engine etc.) can be executed normally.</p> <p>NOTE: If the vehicle is not equipped with cruise control, Go to step 17.</p>	Are the name and year of the system displayed on the select monitor?	Inspect cruise control module.	Go to step 17.
17	<p>CHECK HARNESS CONNECTOR BETWEEN EACH CONTROL MODULE AND DATA LINK CONNECTOR.</p> <p>1) Turn ignition switch to OFF. 2) Disconnect TCM, ECM, ABSCM&H/U and cruise control module connectors. 3) Measure resistance between data link connector and chassis ground.</p> <p>Connector & terminal (B40) No. 5 — Chassis ground: (B40) No. 4 — Chassis ground:</p>	Is the resistance more than 1M Ω ?	Go to step 18.	Repair harness and connector between each control module and data link connector.
18	<p>CHECK OUTPUT SIGNAL FOR TCM.</p> <p>1) Turn ignition switch to ON. 2) Measure voltage between data link connector and chassis ground.</p> <p>Connector & terminal (B40) No. 5 — Chassis ground: (B40) No. 4 — Chassis ground:</p>	Is the voltage more than 1 V?	Repair harness and connector between each control module and data link connector.	A temporary poor contact of the connector or harness may be the cause. Repair harness or connector in the circuit.
19	<p>CHECK HARNESS/CONNECTOR BETWEEN TCM AND DATA LINK CONNECTOR.</p> <p>Measure resistance between TCM connector and data link connector.</p> <p>Connector & terminal (B56) No. 6 — (B40) No. 5: (B56) No. 15 — (B40) No. 4:</p>	Is the resistance less than 0.5 Ω ?	Go to step 20.	Repair harness and connector between TCM and data link connector.
20	<p>CHECK INSTALLATION OF TCM CONNECTOR.</p> <p>Turn ignition switch to OFF.</p>	Is TCM connector inserted into TCM?	Go to step 21.	Insert TCM connector into TCM.
21	<p>CHECK POOR CONTACT IN CONNECTORS.</p>	Is there poor contact in control module and data link connector?	Repair poor contact.	Replace TCM. <Ref. to AT-48, Transmission Control Module (TCM).>

DIAGNOSTIC PROCEDURE WITH TROUBLE CODE

Automatic Transmission (Diagnostics)

14. Diagnostic Procedure with Trouble Code S004509

A: TROUBLE CODE 11 — ENGINE SPEED SIGNAL — S004509C39

DIAGNOSIS:

Engine speed input signal circuit is open or shorted.

TROUBLE SYMPTOM:

- No lock-up (after engine warm-up).
- POWER indicator light remains on when vehicle speed is "0".

WIRING DIAGRAM:

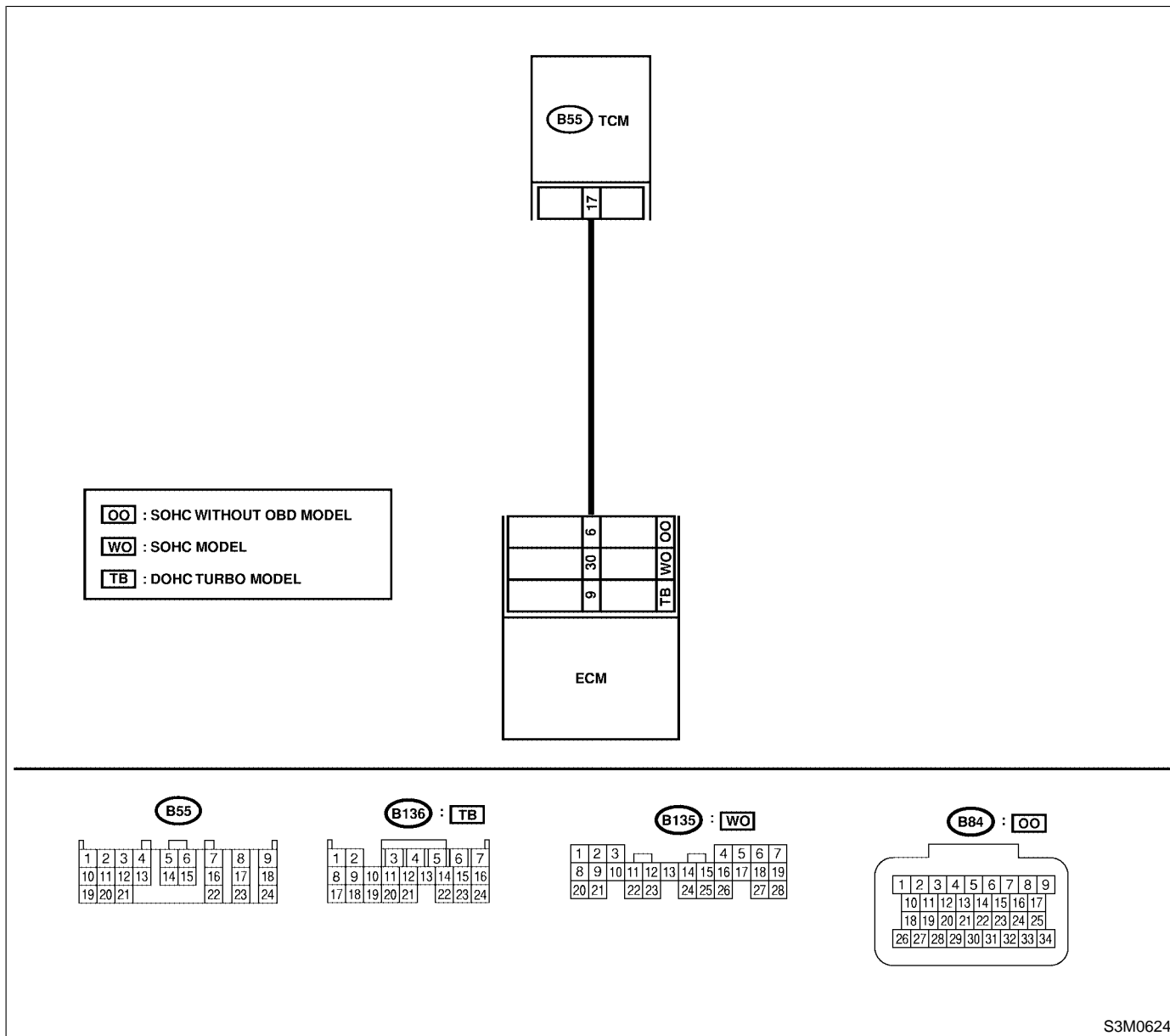

S3M0624

DIAGNOSTIC PROCEDURE WITH TROUBLE CODE

Automatic Transmission (Diagnostics)

No.	Step	Check	Yes	No
1	<p>CHECK HARNESS CONNECTOR BETWEEN TCM AND ECM. 1) Turn ignition switch to OFF. 2) Disconnect connectors from TCM and ECM. 3) Measure resistance of harness between TCM and ECM connector.</p> <p>Connector & terminal SOHC model: (B55) No. 17 — (B135) No. 30: SOHC without OBD: (B55) No. 17 — (B84) No. 6: DOHC TURBO: (B55) No. 17 — (B136) No. 9:</p>	Is the resistance less than 1 Ω?	Go to step 2.	Repair open circuit in harness between TCM and ECM connector.
2	<p>CHECK HARNESS CONNECTOR BETWEEN TCM AND ECM. Measure resistance of harness between TCM connector and chassis ground.</p> <p>Connector & terminal (B55) No. 17 — Chassis ground:</p>	Is the resistance more than 1 MΩ?	Go to step 3.	Repair short circuit in harness between TCM and ECM connector.
3	PREPARE SUBARU SELECT MONITOR.	Do you have a Subaru Select Monitor?	Go to step 5.	Go to step 4.
4	<p>CHECK INPUT SIGNAL FOR TCM. 1) Connect connectors to TCM and ECM. 2) Turn ignition switch to ON (engine OFF). 3) Measure voltage between TCM connector and chassis ground.</p> <p>Connector & terminal (B55) No. 17 (+) — Chassis ground (-):</p>	Is the voltage more than 10.5 V?	Even if "POWER" indicator lights up, the circuit has returned to a normal condition at this time. A temporary poor contact of the connector or harness may be the cause. Repair harness or connector in the TCM and ECM.	Go to step 6.
5	<p>CHECK INPUT SIGNAL FOR TCM USING SUBARU SELECT MONITOR. 1) Connect connectors to TCM and ECM. 2) Connect Subaru Select Monitor to data link connector. 3) Start the engine, and turn Subaru Select Monitor switch to ON. 4) Warm-up the engine until engine coolant temperature is above 80°C (176°F). 5) Engine idling. 6) Read data of engine speed using Subaru Select Monitor. ● Display shows engine speed signal value sent from ECM.</p>	Is the revolution value the same as the tachometer reading shown on the combination meter?	Even if "POWER" indicator lights up, the circuit has returned to a normal condition at this time. A temporary poor contact of the connector or harness may be the cause. Repair harness or connector in the TCM and ECM.	Go to step 6.
6	CHECK POOR CONTACT.	Is there poor contact in engine speed signal circuit?	Repair poor contact.	Go to step 7.
7	CONFIRM TROUBLE CODE 11.	Replace ECM with a new one. Does the trouble code appear again, after the memory has been cleared?	Replace TCM. <Ref. to AT-48, Transmission Control Module (TCM).>	Replace ECM.

DIAGNOSTIC PROCEDURE WITH TROUBLE CODE

Automatic Transmission (Diagnostics)

B: TROUBLE CODE 23 — MASS AIR FLOW SIGNAL — S004509101

DIAGNOSIS:

Input signal circuit of TCM from ECM is open or shorted.

TROUBLE SYMPTOM:

Excessive shift shock.

WIRING DIAGRAM:

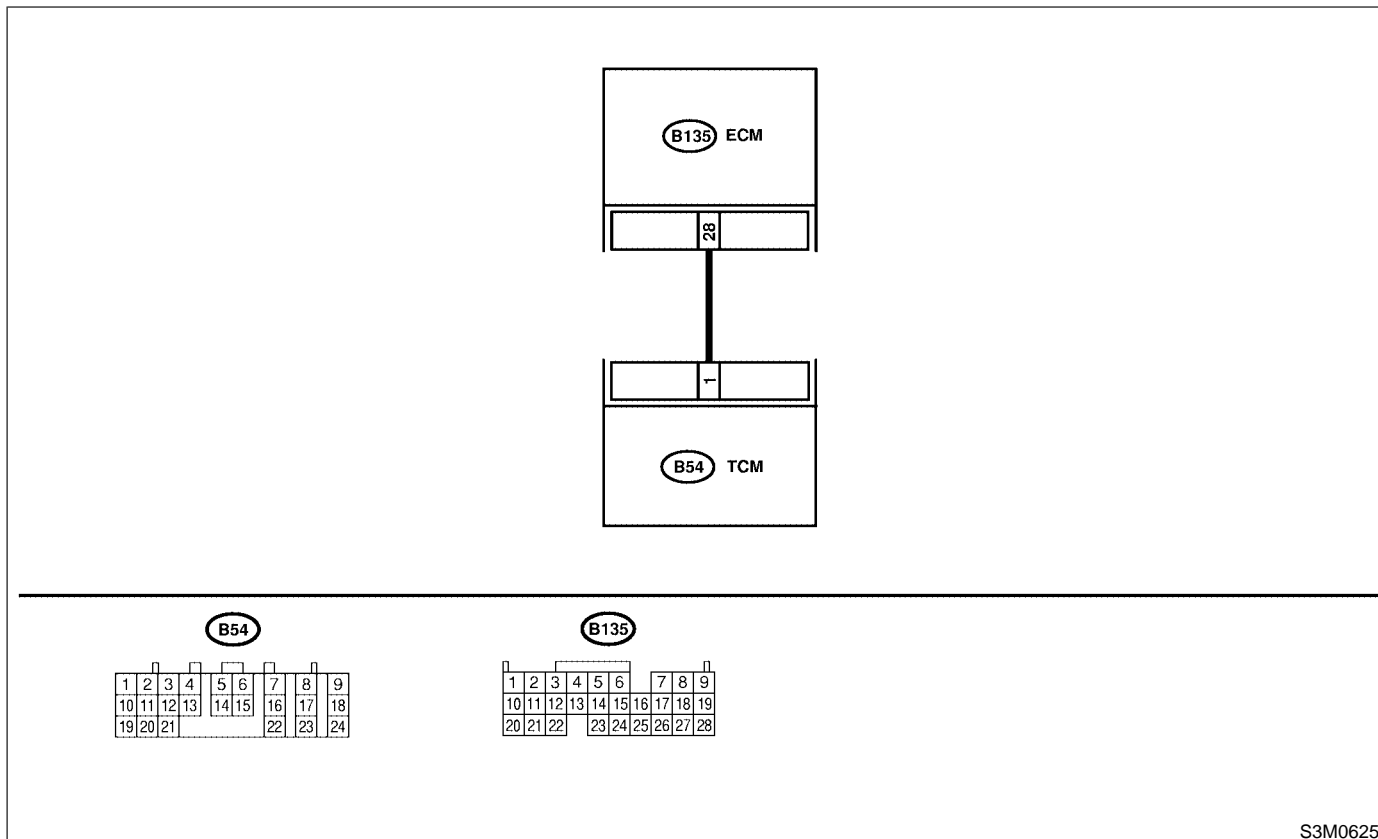

No.	Step	Check	Yes	No
1	CHECK ENGINE GROUND TERMINALS AND GROUND CIRCUIT OF ECM <Ref. to AT-50, TROUBLE CODE 31 - THROTTLE POSITION SENSOR -, Diagnostic Procedure with Trouble Code.>	Is there any trouble?	Repair ground terminal and/or ground circuit of ECM.	Go to step 2.
2	CHECK HARNESS CONNECTOR BETWEEN TCM AND ECM. 1) Turn ignition switch to OFF. 2) Disconnect connectors from TCM and ECM. 3) Measure resistance of harness between TCM and ECM connector. <i>Connector & terminal</i> <i>(B54) No. 1 — (B135) No. 28:</i>	Is the resistance less than 1 Ω?	Go to step 3.	Repair open circuit in harness between TCM and ECM connector.
3	CHECK HARNESS CONNECTOR BETWEEN TCM AND ECM. Measure resistance of harness between TCM connector and chassis ground. <i>Connector & terminal</i> <i>(B54) No. 1 — Chassis ground:</i>	Is the resistance more than 1 MΩ?	Go to step 4.	Repair short circuit in harness between TCM and ECM connector.
4	PREPARE SUBARU SELECT MONITOR.	Do you have a Subaru Select Monitor?	Go to step 6.	Go to step 5.

DIAGNOSTIC PROCEDURE WITH TROUBLE CODE

Automatic Transmission (Diagnostics)

No.	Step	Check	Yes	No
5	<p>CHECK INPUT SIGNAL FOR TCM.</p> <p>1) Connect connectors to TCM and ECM. 2) Start the engine, and warm-up the transmission until ATF temperature is above 80°C (176°F). NOTE: If ambient temperature is below 0°C (32°F), drive the vehicle until the ATF reaches its operating temperature. 3) Engine idling. 4) Measure voltage between TCM connector and chassis ground.</p> <p>Connector & terminal (B54) No. 1 (+) — Chassis ground (-):</p>	Is the voltage between 0.4 and 1.8 V?	Even if "POWER" indicator lights up, the circuit has returned to a normal condition at this time. A temporary poor contact of the connector or harness may be the cause. Repair harness or connector in the TCM and ECM.	Go to step 7.
6	<p>CHECK INPUT SIGNAL FOR TCM USING SUBARU SELECT MONITOR.</p> <p>1) Connect connectors to TCM and ECM. 2) Connect Subaru Select Monitor to data link connector. 3) Start the engine, and turn Subaru Select monitor switch to ON. 4) Warm-up the engine until engine coolant temperature is above 80°C (176°F). 5) Engine idling. 6) Read data of intake manifold pressure signal using Subaru Select Monitor. ● Display shows intake manifold pressure signal value sent from ECM.</p>	Is the value between 0.4 and 1.8 V?	Even if "POWER" indicator lights up, the circuit has returned to a normal condition at this time. A temporary poor contact of the connector or harness may be the cause. Repair harness or connector in the TCM and ECM.	Go to step 7.
7	<p>CHECK POOR CONTACT.</p>	Is there poor contact in intake manifold pressure signal circuit?	Repair poor contact.	Replace TCM. <Ref. to AT-48, Transmission Control Module (TCM).>

DIAGNOSTIC PROCEDURE WITH TROUBLE CODE

Automatic Transmission (Diagnostics)

C: TROUBLE CODE 27 — ATF TEMPERATURE SENSOR — S004509C76

DIAGNOSIS:

Input signal circuit of TCM to ATF temperature sensor is open or shorted.

TROUBLE SYMPTOM:

Excessive shift shock.

WIRING DIAGRAM:

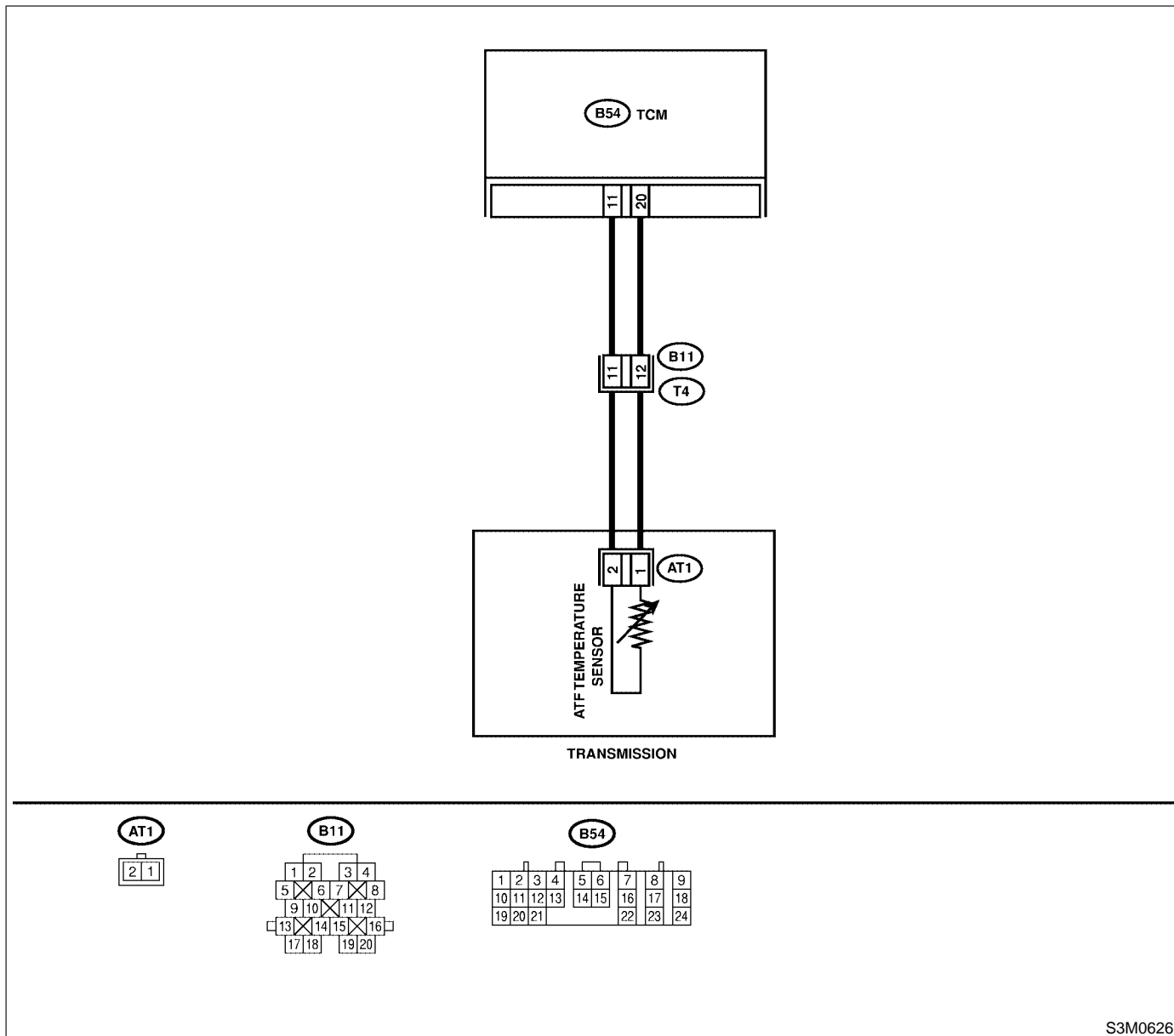

S3M0626

DIAGNOSTIC PROCEDURE WITH TROUBLE CODE

Automatic Transmission (Diagnostics)

No.	Step	Check	Yes	No
1	<p>CHECK HARNESS CONNECTOR BETWEEN TCM AND ATF TEMPERATURE SENSOR.</p> <p>1) Turn ignition switch to OFF. 2) Disconnect connector from transmission and TCM. 3) Measure resistance of harness between TCM and transmission connector.</p> <p>Connector & terminal (B54) No. 20 — (B11) No. 12:</p>	Is the resistance less than 1 Ω?	Go to step 2.	Repair open circuit in harness between TCM and transmission connector.
2	<p>CHECK HARNESS CONNECTOR BETWEEN TCM AND ATF TEMPERATURE SENSOR.</p> <p>Measure resistance of harness between TCM and transmission connector.</p> <p>Connector & terminal (B54) No. 11 — (B11) No. 11:</p>	Is the resistance less than 1 Ω?	Go to step 3.	Repair open circuit in harness between TCM and transmission connector.
3	<p>CHECK HARNESS CONNECTOR BETWEEN TCM AND ATF TEMPERATURE SENSOR.</p> <p>Measure resistance of harness between TCM connector and chassis ground.</p> <p>Connector & terminal (B54) No. 20 — Chassis ground:</p>	Is the resistance more than 1 MΩ?	Go to step 4.	Repair short circuit in harness between TCM and transmission connector.
4	<p>CHECK HARNESS CONNECTOR BETWEEN TCM AND ATF TEMPERATURE SENSOR.</p> <p>Measure resistance of harness between TCM connector and chassis ground.</p> <p>Connector & terminal (B54) No. 11 — Chassis ground:</p>	Is the resistance more than 1 MΩ?	Go to step 5.	Repair short circuit in harness between TCM and transmission connector.
5	<p>CHECK ATF TEMPERATURE SENSOR.</p> <p>1) Turn ignition switch to OFF. 2) Connect connectors to transmission and TCM. 3) Turn ignition switch to ON and start engine. 4) Warm-up the transmission until ATF temperature reaches to 80°C (176°F). NOTE: If ambient temperature is below 0°C (32°F), drive the vehicle until the ATF reaches its operating temperature. 5) Disconnect connector from transmission. 6) Measure resistance between transmission connector terminals.</p> <p>Connector & terminal (T4) No. 11 — No. 12:</p>	Is the resistance between 275 and 375 Ω?	Go to step 6.	Go to step 11.
6	<p>CHECK ATF TEMPERATURE SENSOR.</p> <p>1) Turn ignition switch to ON (engine OFF). 2) Measure resistance between transmission connector terminals.</p> <p>Connector & terminal (T4) No. 11 — No. 12:</p>	Does the resistance value increase while the ATF temperature decreases?	Go to step 7.	Go to step 11.
7	<p>PREPARE SUBARU SELECT MONITOR.</p>	Do you have a Subaru Select Monitor?	Go to step 9.	Go to step 8.

DIAGNOSTIC PROCEDURE WITH TROUBLE CODE

Automatic Transmission (Diagnostics)

No.	Step	Check	Yes	No
8	<p>CHECK INPUT SIGNAL FOR TCM. 1) Connect connector to transmission. 2) Warm-up the transmission until ATF temperature is about 80°C (176°F). NOTE: If ambient temperature is below 0°C (32°F), drive the vehicle until the ATF reaches its operating temperature. 3) Measure voltage between TCM connector terminal.</p> <p>Connector & terminal (B54) No. 11 (+) — No. 20 (-):</p>	Is the voltage between 0.4 and 0.9 V?	Even if "POWER" indicator lights up, the circuit has returned to a normal condition at this time. Temporary poor contact of the connector or harness may be the case. Repair harness or contact in the ATF temperature sensor and transmission connector.	Go to step 10.
9	<p>CHECK INPUT SIGNAL FOR TCM USING SUBARU SELECT MONITOR. 1) Connect connector to transmission. 2) Turn ignition switch to ON (engine OFF).</p>	Does the ATF temperature gradually decrease?	Even if "POWER" indicator lights up, the circuit has returned to a normal condition at this time. Temporary poor contact of the connector or harness may be the case. Repair harness or contact in the ATF temperature sensor and transmission connector.	Go to step 10.
10	<p>CHECK POOR CONTACT.</p>	Is there poor contact in ATF temperature sensor circuit?	Repair poor contact.	Replace TCM. <Ref. to AT-48, Transmission Control Module (TCM).>
11	<p>CHECK HARNESS CONNECTOR BETWEEN TRANSMISSION AND ATF TEMPERATURE SENSOR. 1) Turn ignition switch to OFF. 2) Disconnect connector from transmission. 3) Remove transmission connector from bracket. 4) Lift-up the vehicle and place safety stand. CAUTION: On AWD models, raise all wheels off ground. 5) Drain automatic transmission fluid. CAUTION: Do not drain the automatic transmission fluid until it cools down. 6) Remove oil pan, and disconnect connector from ATF temperature sensor connector. 7) Measure resistance of harness between ATF temperature sensor and transmission connector.</p> <p>Connector & terminal (T4) No. 11 — (AT1) No. 2:</p>	Is the resistance less than 1 Ω?	Go to step 12.	Repair open circuit in harness between ATF temperature sensor and transmission connector.

DIAGNOSTIC PROCEDURE WITH TROUBLE CODE

Automatic Transmission (Diagnostics)

No.	Step	Check	Yes	No
12	CHECK HARNESS CONNECTOR BETWEEN TRANSMISSION AND ATF TEMPERATURE SENSOR. Measure resistance of harness between ATF temperature sensor and transmission connector. Connector & terminal (T4) No. 12 — (AT1) No. 1:	Is the resistance less than 1 Ω ?	Go to step 13.	Repair open circuit in harness between ATF temperature sensor and transmission connector.
13	CHECK HARNESS CONNECTOR BETWEEN TRANSMISSION AND ATF TEMPERATURE SENSOR. Measure resistance of harness between transmission connector and transmission ground. Connector & terminal (T4) No. 11 — Transmission ground:	Is the resistance more than 1 M Ω ?	Go to step 14.	Repair short circuit in harness between ATF temperature sensor and transmission connector.
14	CHECK HARNESS CONNECTOR BETWEEN TRANSMISSION AND ATF TEMPERATURE SENSOR. Measure resistance of harness between transmission connector and transmission ground. Connector & terminal (T4) No. 12 — Transmission ground:	Is the resistance more than 1 M Ω ?	Replace ATF temperature sensor. <Ref. to AT-41, Shift Solenoids, Duty Solenoids and ATF Temperature Sensor.>	Repair short circuit in harness between ATF temperature sensor and transmission connector.

DIAGNOSTIC PROCEDURE WITH TROUBLE CODE

Automatic Transmission (Diagnostics)

D: TROUBLE CODE 31 — THROTTLE POSITION SENSOR — S004509C94

DIAGNOSIS:

Input signal circuit of throttle position sensor is open or shorted.

TROUBLE SYMPTOM:

Shift point too high or too low; excessive shift shock; excessive tight corner "braking".

WIRING DIAGRAM:

SOHC w/o OBD

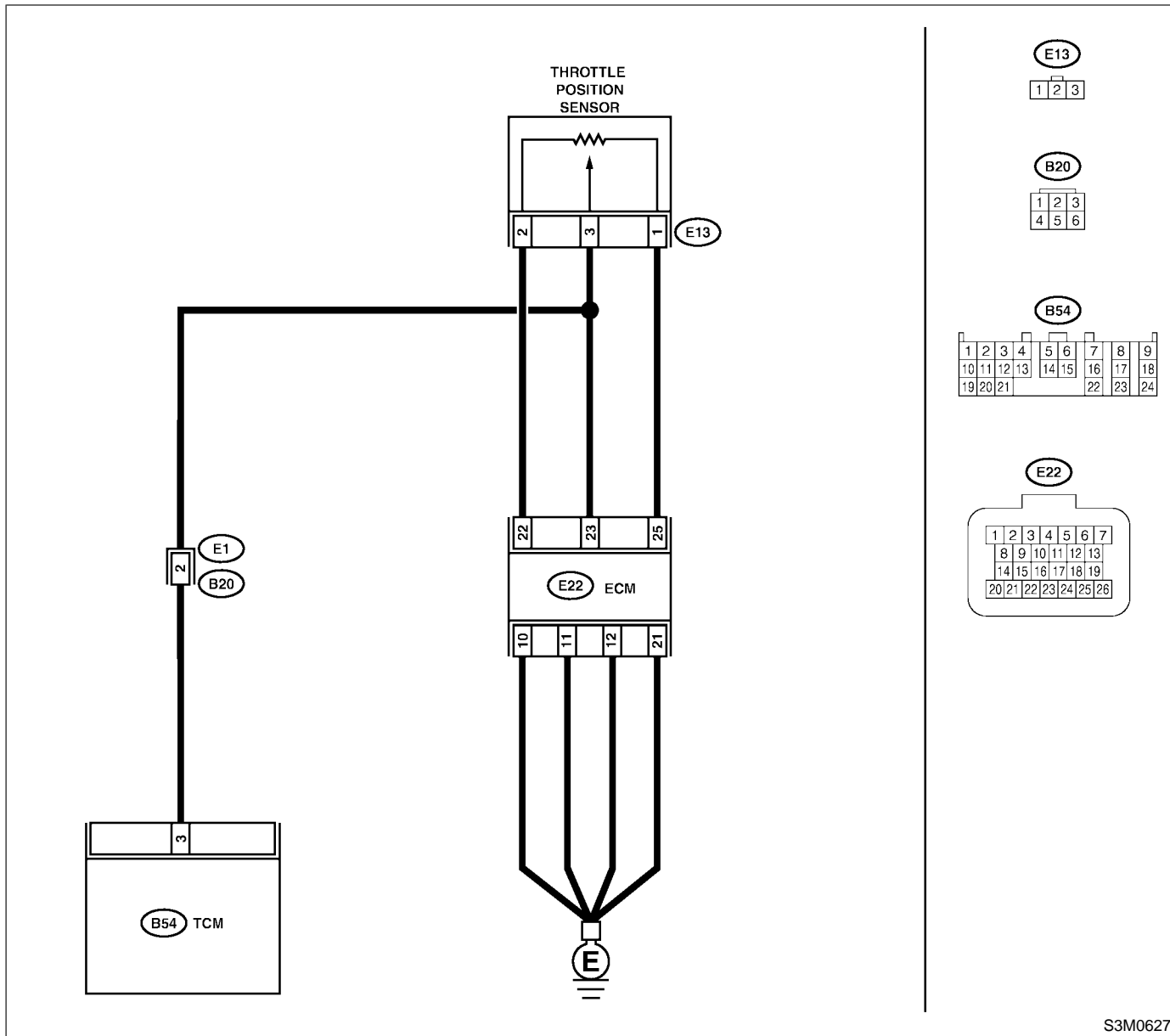

S3M0627

DIAGNOSTIC PROCEDURE WITH TROUBLE CODE

Automatic Transmission (Diagnostics)

SOHC

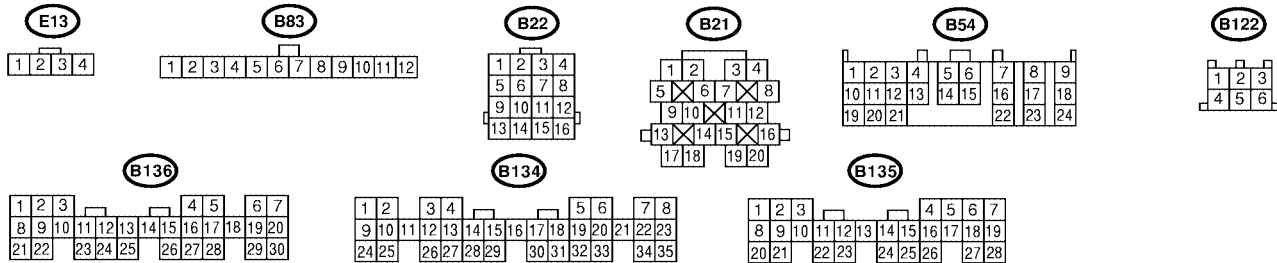
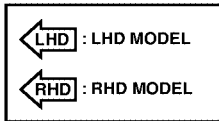
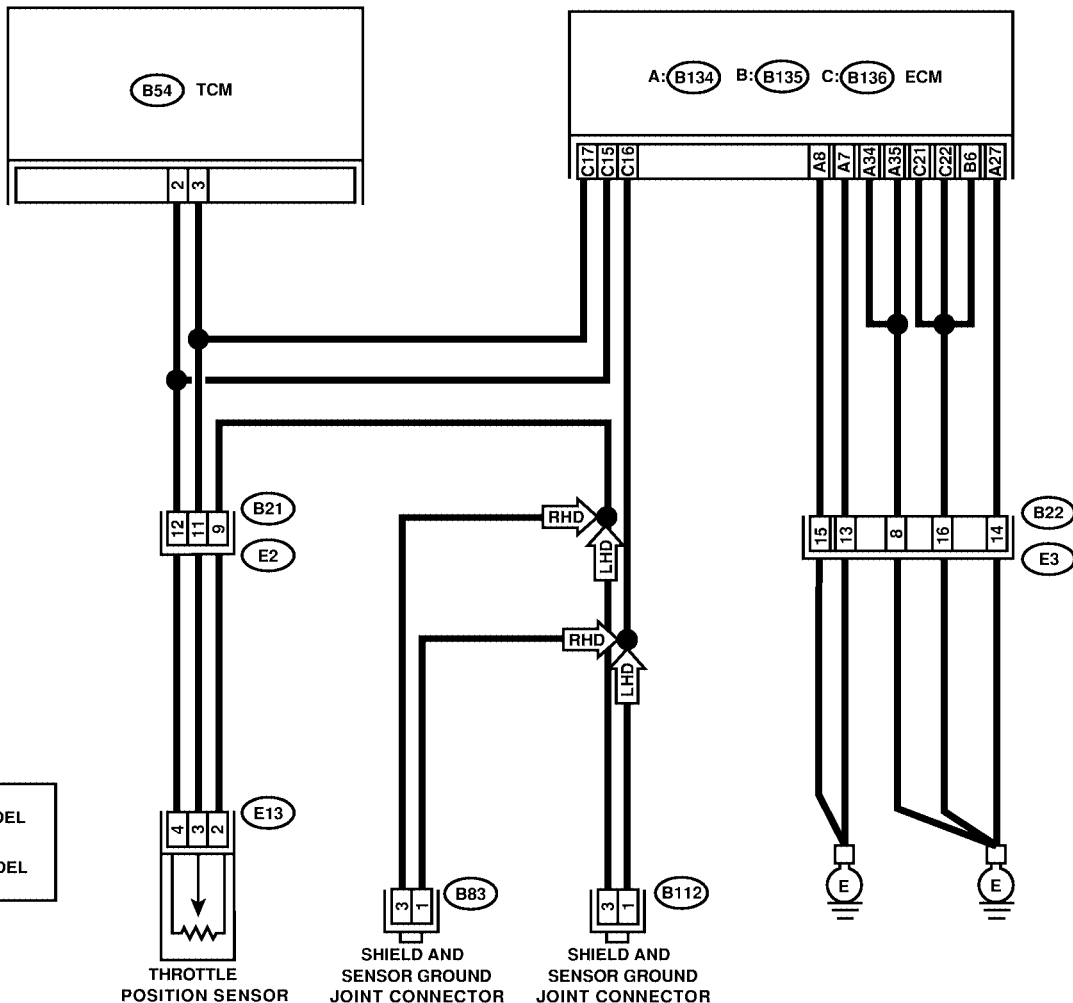

S3M0628

DIAGNOSTIC PROCEDURE WITH TROUBLE CODE

Automatic Transmission (Diagnostics)

DOHC TURBO FOR LHD

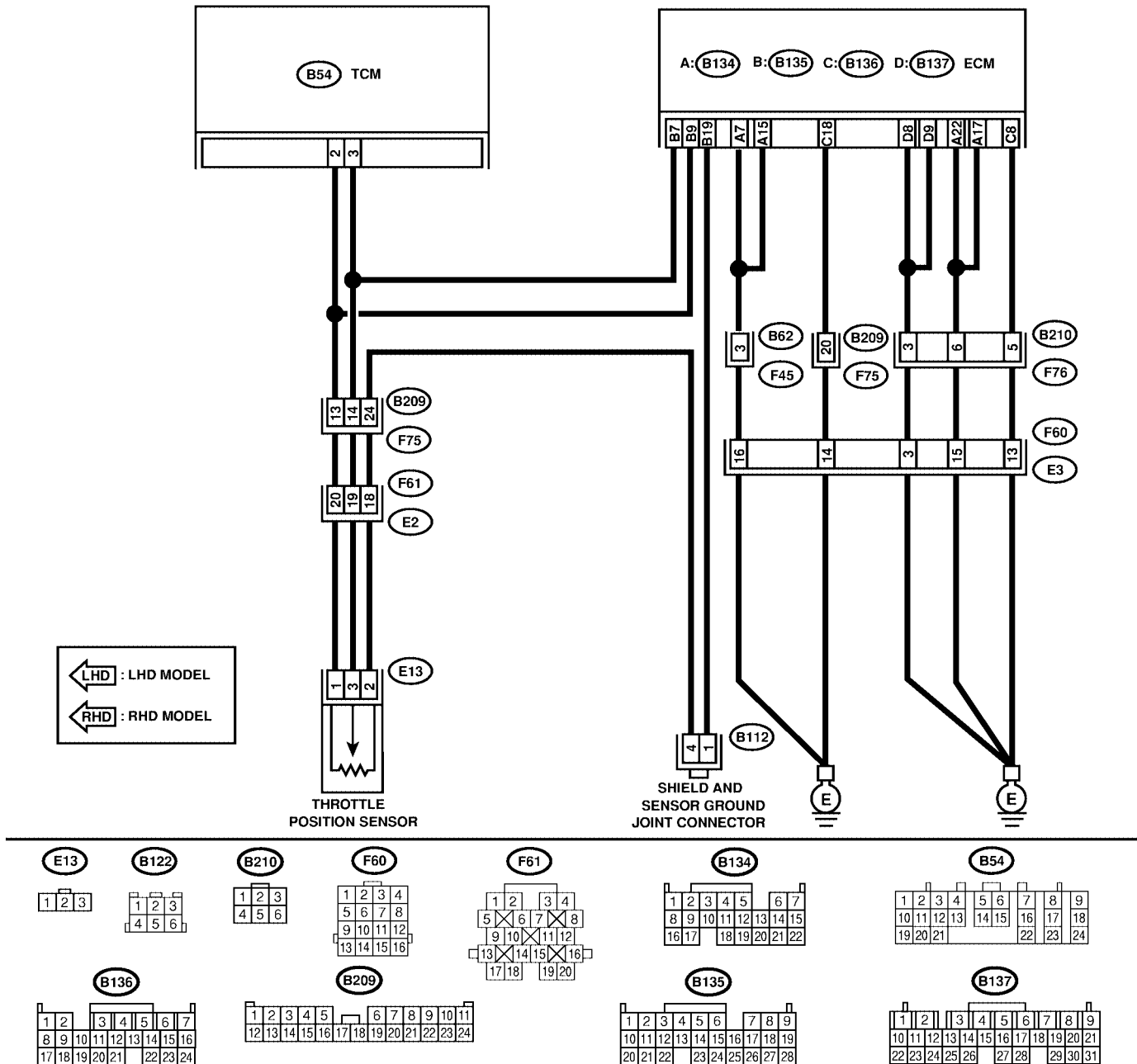

S3M0647

DIAGNOSTIC PROCEDURE WITH TROUBLE CODE

Automatic Transmission (Diagnostics)

DOHC TURBO FOR RHD

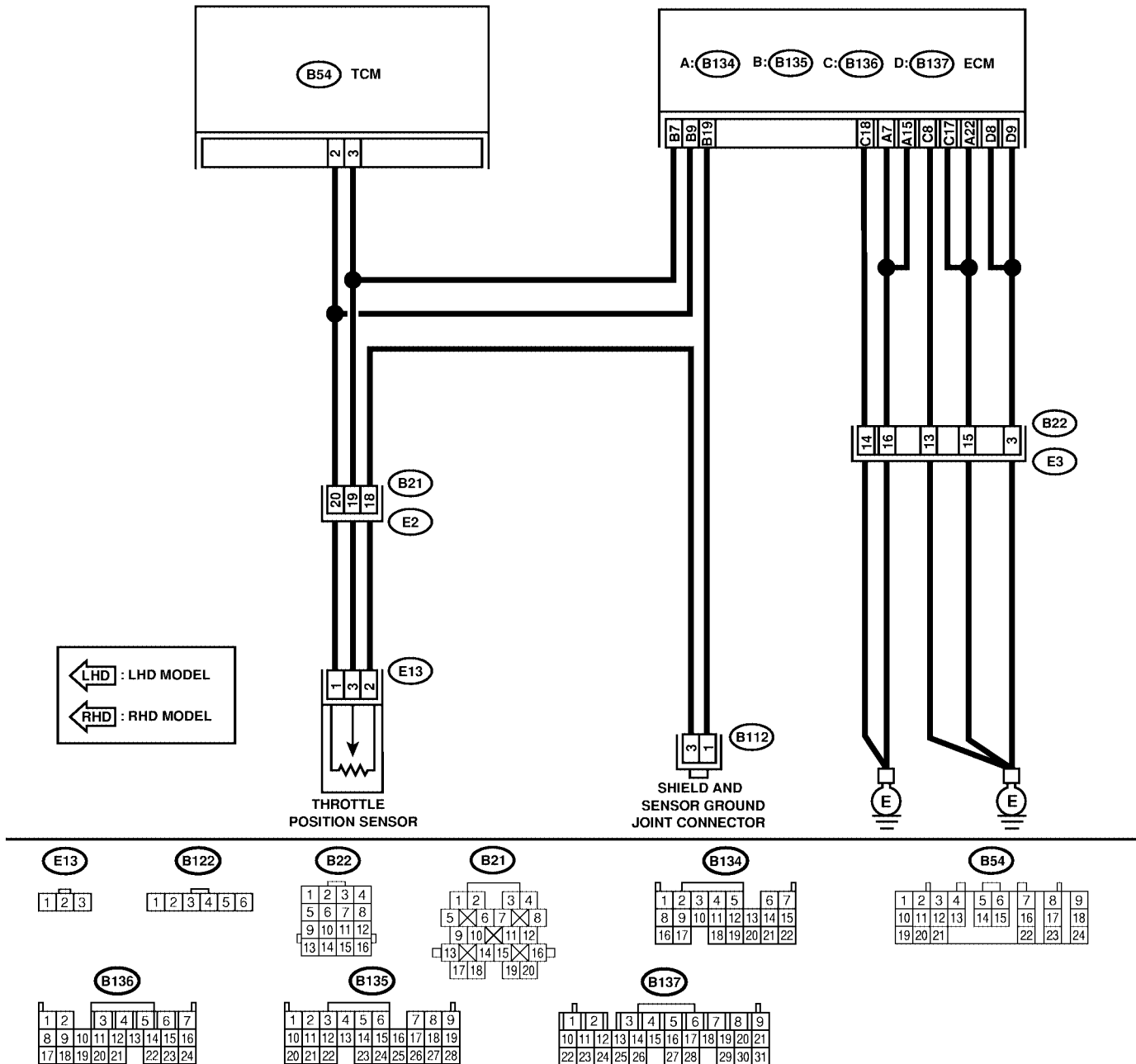

S3M0648

DIAGNOSTIC PROCEDURE WITH TROUBLE CODE

Automatic Transmission (Diagnostics)

No.	Step	Check	Yes	No
1	CHECK ENGINE GROUND TERMINALS.	Have engine ground terminals been tightened?	Go to step 2.	Tighten engine ground terminals.
2	CHECK GROUND CIRCUIT OF ECM. 1) Turn ignition switch to OFF. 2) Disconnect connector from ECM. 3) Measure resistance of harness between ECM and engine ground. Connector & terminal SOHC MODEL: (B134) No. 27 — Engine ground: (B134) No. 8 — Engine ground: (B134) No. 7 — Engine ground: (B136) No. 21 — Engine ground: (B136) No. 22 — Engine ground: (B134) No. 35 — Engine ground: (B134) No. 34 — Engine ground: (B135) No. 6 — Engine ground: SOHC w/o OBD MODEL (E22) No. 10 — Engine ground: (E22) No. 11 — Engine ground: (E22) No. 12 — Engine ground: (E22) No. 21 — Engine ground: DOHC TURBO MODEL: (B134) No. 7 — Engine ground: (B134) No. 15 — Engine ground: (B134) No. 22 — Engine ground: (B136) No. 8 — Engine ground: (B136) No. 17 — Engine ground: (B136) No. 18 — Engine ground: (B137) No. 8 — Engine ground: (B137) No. 9 — Engine ground:	Is the resistance less than 5 Ω?	Go to step 3.	Repair open circuit in harness between ECM connector and engine grounding terminal.
3	CHECK THROTTLE POSITION SENSOR. 1) Disconnect connector from throttle position sensor. 2) Measure resistance between throttle position sensor connector receptacle's terminals. Terminals SOHC MODEL: No. 4 — No. 2: EXCEPT SOHC MODEL: No. 1 — No. 2:	Is the resistance between 3.0 and 4.2 kΩ?	Go to step 4.	Replace throttle position sensor.
4	CHECK THROTTLE POSITION SENSOR. Measure resistance between throttle position sensor connector receptacle's terminals. Terminals No. 2 — No. 3:	Is the resistance between 0.35 and 0.5 kΩ?	Go to step 5.	Replace throttle position sensor.
5	CHECK HARNESS CONNECTOR BETWEEN TCM AND THROTTLE POSITION SENSOR. 1) Disconnect connector from TCM. 2) Measure resistance of harness between TCM and throttle position sensor connector. Connector & terminal (B55) No. 3 — (E13) No. 3:	Is the resistance less than 1 Ω?	Go to step 6.	Repair open circuit in harness between TCM and throttle position sensor connector, and poor contact in coupling connector.

DIAGNOSTIC PROCEDURE WITH TROUBLE CODE

Automatic Transmission (Diagnostics)

No.	Step	Check	Yes	No
6	<p>CHECK HARNESS CONNECTOR BETWEEN TCM AND THROTTLE POSITION SENSOR. Measure resistance of harness between TCM and throttle position sensor connector. Connector & terminal (B54) No. 2 — (E13) No. 4: NOTE: If SOHC w/o OBD model, Go to step 7.</p>	Is the resistance less than 1 Ω ?	Go to step 7.	Repair open circuit in harness between TCM and throttle position sensor connector, and poor contact in coupling connector.
7	<p>CHECK HARNESS CONNECTOR BETWEEN TCM AND THROTTLE POSITION SENSOR. Measure resistance of harness between TCM connector and chassis ground. Connector & terminal (B54) No. 3 — Chassis ground:</p>	Is the resistance more than 1 M Ω ?	Go to step 8.	Repair short circuit in harness between TCM and throttle position sensor connector.
8	<p>CHECK HARNESS CONNECTOR BETWEEN TCM AND THROTTLE POSITION SENSOR. Measure resistance of harness between TCM connector and chassis ground. Connector & terminal (B54) No. 2 — Chassis ground:</p>	Is the resistance more than 1 M Ω ?	Go to step 9.	Repair short circuit in harness between TCM and throttle position sensor connector.
9	<p>CHECK HARNESS CONNECTOR BETWEEN TCM AND ECM. Measure resistance of harness between TCM and ECM connector. Connector & terminal SOHC w/o OBD MODEL: (B54) No. 3 — (E22) No. 23: SOHC MODEL: (B54) No. 3 — (B136) No. 17: DOHC TURBO: (B54) No. 3 — (B135) No. 7:</p>	Is the resistance less than 1 Ω ?	Go to step 10.	Repair open circuit in harness between TCM and ECM connector.
10	<p>CHECK HARNESS CONNECTOR BETWEEN TCM AND ECM. Measure resistance of harness between TCM and ECM connector. Connector & terminal (B54) No. 2 — (B136) No. 15: NOTE: If SOHC w/o OBD model, Go to step 11.</p>	Is the resistance less than 1 Ω ?	Go to step 11.	Repair open circuit in harness between TCM and ECM connector.
11	PREPARE SUBARU SELECT MONITOR.	Do you have a Subaru Select Monitor?	Go to step 14.	Go to step 12.
12	<p>CHECK INPUT SIGNAL FOR TCM. 1) Connect connectors to TCM, throttle position sensor and ECM. 2) Turn ignition switch to ON (engine OFF). 3) Close the throttle completely. 4) Measure voltage between TCM connector and chassis ground. Connector & terminal (B54) No. 3 (+) — Chassis ground (-):</p>	Is the voltage between 0.3 and 0.7 V in throttle fully closed?	Go to step 13.	Go to step 18.
13	<p>CHECK INPUT SIGNAL FOR TCM. 1) Open the throttle completely. 2) Measure voltage between TCM connector and chassis ground. Connector & terminal (B54) No. 3 (+) — Chassis ground (-):</p>	Is the voltage between 4.0 and 4.6 V with throttle fully open?	Go to step 16.	Go to step 18.

DIAGNOSTIC PROCEDURE WITH TROUBLE CODE

Automatic Transmission (Diagnostics)

No.	Step	Check	Yes	No
14	<p>CHECK INPUT SIGNAL FOR TCM USING SUBARU SELECT MONITOR.</p> <p>1) Connect connectors to TCM, throttle position sensor and ECM. 2) Connect Subaru Select Monitor to data link connector. 3) Turn ignition switch to ON (engine OFF). 4) Turn Subaru Select Monitor switch to ON. 5) Throttle fully closed. 6) Read data of throttle position sensor using Subaru Select Monitor.</p> <p>● Throttle position sensor input signal is indicated.</p>	Is the value voltage between 0.3 and 0.7 V?	Go to step 15.	Go to step 18.
15	<p>CHECK INPUT SIGNAL FOR TCM USING SUBARU SELECT MONITOR.</p> <p>Throttle fully open.</p> <p>NOTE: Must be changed correspondingly with accelerator pedal operation (from "released" to "depressed" position).</p>	Is the value voltage between 4.0 and 4.6 V?	Go to step 17.	Go to step 18.
16	<p>CHECK INPUT SIGNAL FOR TCM (THROTTLE POSITION SENSOR POWER SUPPLY).</p> <p>Measure voltage between TCM connector and chassis ground.</p> <p>Connector & terminal <i>(B54) No. 2 (+) — Chassis ground (-):</i></p>	Is the voltage between 4.8 and 5.3 V?	Even if "POWER" indicator lights up, the circuit has returned to a normal condition at this time. A temporary poor contact of the connector or harness may be the cause. Repair harness or connector in throttle position sensor circuit.	Go to step 18.
17	<p>CHECK INPUT SIGNAL FOR TCM USING SUBARU SELECT MONITOR (THROTTLE POSITION SENSOR POWER SUPPLY).</p> <p>Read data of throttle position sensor power supply using Subaru Select Monitor.</p> <p>● Throttle position sensor power supply voltage is indicated.</p>	Is the value voltage between 4.8 and 5.3 V?	Even if "POWER" indicator lights up, the circuit has returned to a normal condition at this time. A temporary poor contact of the connector or harness may be the cause. Repair harness or connector in throttle position sensor circuit.	Go to step 18.
18	<p>CHECK POOR CONTACT.</p>	Is there poor contact in throttle position sensor circuit?	Repair poor contact.	Replace TCM. <Ref. to AT-48, Transmission Control Module (TCM).>

DIAGNOSTIC PROCEDURE WITH TROUBLE CODE

Automatic Transmission (Diagnostics)

MEMO:

DIAGNOSTIC PROCEDURE WITH TROUBLE CODE

Automatic Transmission (Diagnostics)

E: TROUBLE CODE 33 — FRONT VEHICLE SPEED SENSOR — S004509F60

DIAGNOSIS:

- The vehicle speed signal is abnormal.
- The circuit in combination meter is faulty.
- The harness connector between TCM and vehicle speed sensor is in short or open.

TROUBLE SYMPTOM:

- Erroneous idling.
- Engine stalls.
- Poor driving performance.

DIAGNOSTIC PROCEDURE WITH TROUBLE CODE

Automatic Transmission (Diagnostics)

WIRING DIAGRAM:

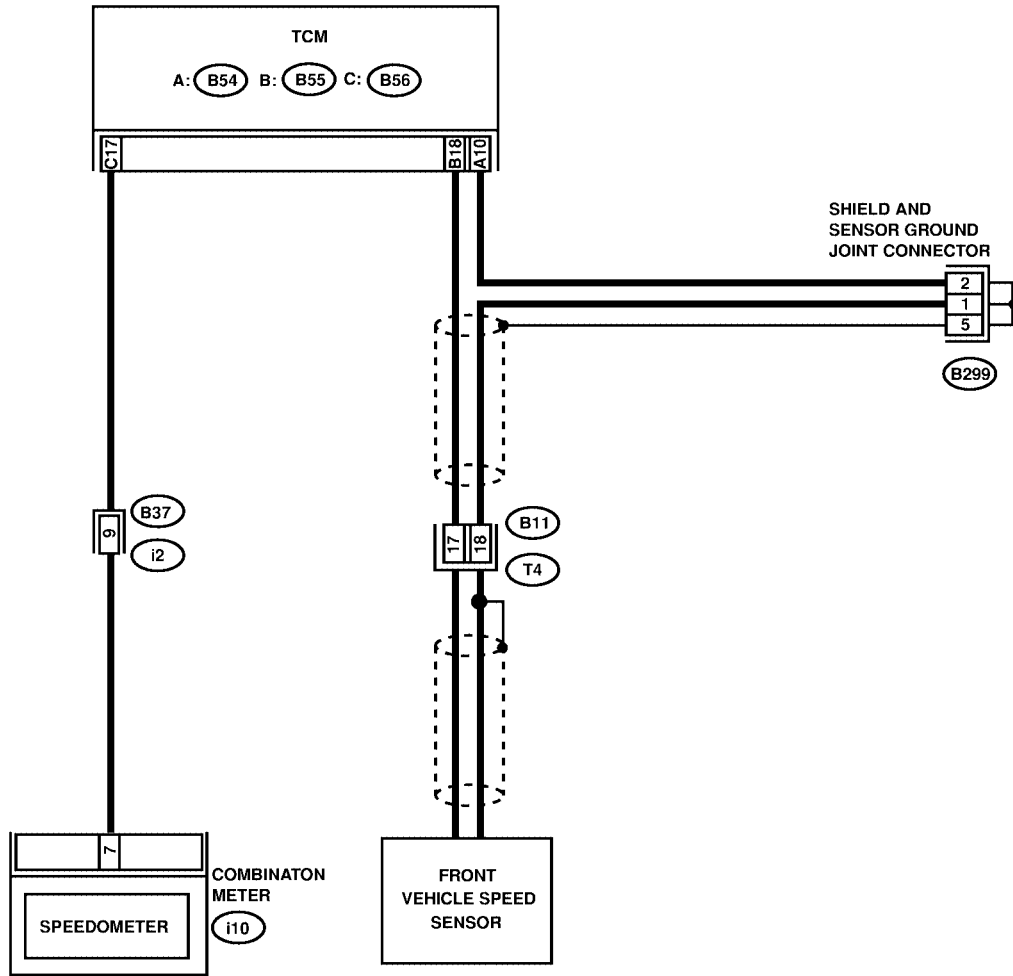

B299



A: i10

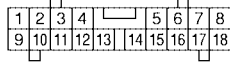

B11

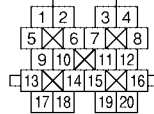

i2

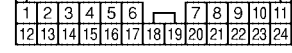

B54

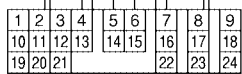

B55

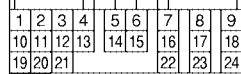

B56

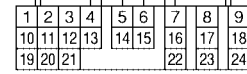

S3M0629

DIAGNOSTIC PROCEDURE WITH TROUBLE CODE

Automatic Transmission (Diagnostics)

No.	Step	Check	Yes	No
1	CHECK HARNESS CONNECTOR BETWEEN TCM AND TRANSMISSION. 1) Turn ignition switch to OFF. 2) Disconnect connector from TCM and transmission. 3) Measure resistance of harness between TCM and transmission connector. Connector & terminal (B55) No. 18 — (B11) No. 17:	Is the resistance less than 1 Ω ?	Go to step 2.	Repair open circuit in harness between TCM and transmission connector.
2	CHECK HARNESS CONNECTOR BETWEEN TCM AND TRANSMISSION. Measure resistance of harness between TCM and transmission connector. Connector & terminal (B54) No. 10 — (B11) No. 18:	Is the resistance less than 1 Ω ?	Go to step 3.	Repair open circuit in harness between TCM and transmission connector, and poor contact in coupling connector.
3	CHECK HARNESS CONNECTOR BETWEEN TCM AND TRANSMISSION. Measure resistance of harness between TCM and transmission connector. Connector & terminal (B54) No. 10 — Chassis ground:	Is the resistance more than 1 M Ω ?	Go to step 4.	Repair short circuit in harness between TCM and transmission connector.
4	CHECK HARNESS CONNECTOR BETWEEN TCM AND TRANSMISSION. Measure resistance of harness between TCM and transmission connector. Connector & terminal (B55) No. 18 — Chassis ground:	Is the resistance more than 1 M Ω ?	Go to step 5.	Repair short circuit in harness between TCM and transmission connector, and poor contact in coupling connector.
5	CHECK FRONT VEHICLE SPEED SENSOR. Measure resistance between transmission connector receptacle's terminals. Connector & terminal (T4) No. 17 — No. 18:	Is the resistance between 450 and 650 Ω ?	Go to step 6.	Replace front vehicle speed sensor. <Ref. to AT-32, Front Vehicle Speed Sensor.>
6	PREPARE OSCILLOSCOPE.	Do you have oscilloscope?	Go to step 9.	Go to step 7.
7	PREPARE SUBARU SELECT MONITOR.	Do you have a Subaru Select Monitor?	Go to step 10.	Go to step 8.

DIAGNOSTIC PROCEDURE WITH TROUBLE CODE

Automatic Transmission (Diagnostics)

No.	Step	Check	Yes	No
8	<p>CHECK INPUT SIGNAL FOR TCM.</p> <p>1) Connect all connectors. 2) Lift-up or raise the vehicle and place safety stands.</p> <p>CAUTION: On AWD models, raise all wheels off floor.</p> <p>3) Start the engine and set vehicle in 20 km/h (12 MPH) condition.</p> <p>NOTE: The speed difference between front and rear wheels may light the ABS warning light, but this indicates no malfunction. When AT control diagnosis is finished, perform the ABS memory clearance procedure of on-board diagnostics system. <Ref. to ABS-22, Clear Memory Mode.></p> <p>4) Measure voltage between TCM connector terminals.</p> <p>Connector & terminal (B55) No. 18 (+) — (B54) No. 10 (-):</p>	Is the voltage more than AC 1 V?	Even if "POWER" indicator lights up, the circuit has returned to a normal condition at this time. A temporary poor connector or harness may be the case. Repair harness or connector in the front vehicle speed sensor circuit.	Go to step 11.
9	<p>CHECK FRONT VEHICLE SPEED SENSOR USING OSCILLOSCOPE.</p> <p>1) Connect all connectors. 2) Lift-up the vehicle and place safety stand.</p> <p>CAUTION: On AWD models, raise all wheels off ground.</p> <p>3) Set oscilloscope to TCM connector terminals. Positive probe; (B55) No. 18 Earth lead; (B54) No. 10</p> <p>4) Start the engine, and drive the wheels slowly.</p> <p>NOTE: The speed difference between front and rear wheels may light the ABS warning light, but this indicates no malfunctions. When AT control diagnosis is finished, perform the ABS memory clearance procedure of self-diagnosis system. <Ref. to ABS-22, Clear Memory Mode.></p> <p>5) Measure signal voltage indicated on oscilloscope.</p>	Is the voltage more than AC 4 V?	Even if "POWER" indicator lights up, the circuit has returned to a normal condition at this time. A temporary poor connector or harness may be the case. Repair harness or connector in the front vehicle speed sensor circuit.	Go to step 11.

DIAGNOSTIC PROCEDURE WITH TROUBLE CODE

Automatic Transmission (Diagnostics)

No.	Step	Check	Yes	No
10	<p>CHECK INPUT SIGNAL FOR TCM USING SUBARU SELECT MONITOR.</p> <p>1) Connect all connectors. 2) Connect Subaru Select Monitor to data link connector. 3) Lift-up or raise the vehicle and place safety stands.</p> <p>CAUTION: On AWD models, raise all wheels off floor.</p> <p>4) Turn ignition switch to ON and turn Subaru Select Monitor switch to ON. 5) Start the engine. 6) Read data of vehicle speed using Subaru Select Monitor.</p> <ul style="list-style-type: none"> ● Compare speedometer with Subaru Select Monitor indications. ● Vehicle speed is indicated in "km/h" or "MPH". <p>7) Slowly increase vehicle speed to 60 km/h or 37 MPH.</p> <p>NOTE: The speed difference between front and rear wheels may light the ABS warning light, but this indicates no malfunction. When AT control diagnosis is finished, perform the ABS memory clearance procedure of on-board diagnostics system. <Ref. to ABS-22, Clear Memory Mode.></p>	<p>Does the speedometer indication increase as the Subaru Select Monitor data increases?</p>	<p>Even if "POWER" indicator lights up, the circuit has returned to a normal condition at this time. A temporary poor connector or harness may be the case. Repair harness or connector in the front vehicle speed sensor circuit.</p>	<p>Go to step 11.</p>
11	<p>CHECK POOR CONTACT.</p>	<p>Is there poor contact in front vehicle speed sensor circuit?</p>	<p>Repair poor contact.</p>	<p>Replace TCM. <Ref. to AT-48, Transmission Control Module (TCM).></p>

DIAGNOSTIC PROCEDURE WITH TROUBLE CODE

Automatic Transmission (Diagnostics)

MEMO:

DIAGNOSTIC PROCEDURE WITH TROUBLE CODE

Automatic Transmission (Diagnostics)

F: TROUBLE CODE 36 — TORQUE CONVERTER TURBINE SPEED SENSOR

S004509D17

DIAGNOSIS:

Input signal circuit of TCM is open or shorted.

TROUBLE SYMPTOM:

Excessive shift shock.

WIRING DIAGRAM:

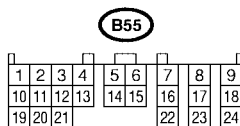
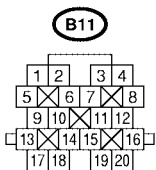
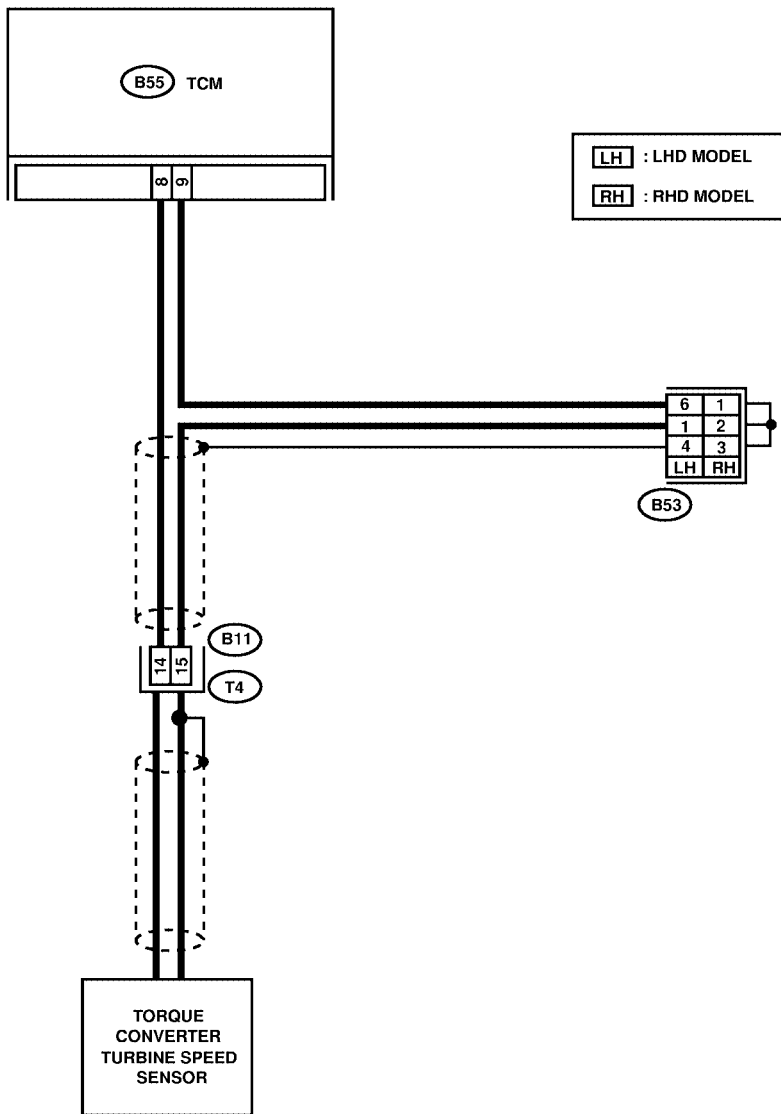

DIAGNOSTIC PROCEDURE WITH TROUBLE CODE

Automatic Transmission (Diagnostics)

No.	Step	Check	Yes	No
1	CHECK TORQUE CONVERTER TURBINE SPEED SENSOR. 1) Turn ignition switch to OFF. 2) Disconnect connector from transmission. 3) Measure resistance between transmission connector receptacle's terminals. <i>Connector & terminal</i> <i>(T4) No. 14 — No. 15:</i>	Is the resistance between 450 and 650 Ω ?	Go to step 2.	Replace turbine speed sensor. <Ref. to AT-37, Torque Converter Turbine Speed Sensor.>
2	CHECK HARNESS CONNECTOR BETWEEN TCM AND TRANSMISSION. 1) Disconnect connector from TCM. 2) Measure resistance of harness between TCM and transmission connector. <i>Connector & terminal</i> <i>(B55) No. 8 — (B11) No. 14:</i>	Is the resistance less than 1 Ω ?	Go to step 3.	Repair open circuit in harness between TCM and transmission connector.
3	CHECK HARNESS CONNECTOR BETWEEN TCM AND TRANSMISSION. Measure resistance of harness between TCM and transmission connector. <i>Connector & terminal</i> <i>(B55) No. 9 — (B11) No. 15:</i>	Is the resistance less than 1 Ω ?	Go to step 4.	Repair open circuit in harness between TCM and transmission connector, and poor contact in coupling connector.
4	CHECK HARNESS CONNECTOR BETWEEN TCM AND TRANSMISSION. Measure resistance of harness between TCM and chassis ground. <i>Connector & terminal</i> <i>(B55) No. 9 — Chassis ground:</i>	Is the resistance more than 1 M Ω ?	Go to step 5.	Repair short circuit in harness between TCM and transmission connector.
5	CHECK HARNESS CONNECTOR BETWEEN TCM AND TRANSMISSION. Measure resistance of harness between TCM and chassis ground. <i>Connector & terminal</i> <i>(B55) No. 8 — Chassis ground:</i>	Is the resistance more than 1 M Ω ?	Go to step 6.	Repair short circuit in harness between TCM and transmission connector, and poor contact in coupling connector.
6	PREPARE OSCILLOSCOPE.	Do you have oscilloscope?	Go to step 10.	Go to step 7.
7	PREPARE SUBARU SELECT MONITOR.	Do you have a Subaru Select Monitor?	Go to step 9.	Go to step 8.
8	CHECK INPUT SIGNAL FOR TCM. 1) Connect connectors to TCM and transmission. 2) Start the engine and move select lever to "P" or "N" range. 3) Measure voltage between TCM connector terminals. <i>Connector & terminal</i> <i>(B55) No. 8 (+) — No. 9 (-):</i>	Is the voltage more than AC 1 V?	Even if "POWER" indicator lights up, the circuit has returned to a normal condition at this time. A temporary poor contact of the connector or harness may be the cause. Repair harness or connector in the TCM and transmission.	Go to step 11.

DIAGNOSTIC PROCEDURE WITH TROUBLE CODE

Automatic Transmission (Diagnostics)

No.	Step	Check	Yes	No
9	<p>CHECK INPUT SIGNAL FOR TCM USING SUBARU SELECT MONITOR.</p> <p>1) Connect connectors to TCM and transmission.</p> <p>2) Connect Subaru Select Monitor to data link connector.</p> <p>3) Turn ignition switch to ON and turn Subaru Select Monitor switch to ON.</p> <p>4) Start the engine.</p> <p>5) Move select lever to "P" or "N" range.</p> <p>6) Read data of turbine speed using Subaru Select Monitor.</p> <ul style="list-style-type: none"> ● Compare tachometer with Subaru Select Monitor indications. 	Is the revolution value same as the tachometer reading shown on the combination meter?	Even if "POWER" indicator lights up, the circuit has returned to a normal condition at this time. A temporary poor contact of the connector or harness may be the cause. Repair harness or connector in the TCM and transmission.	Go to step 11.
10	<p>CHECK INPUT SIGNAL FOR TCM USING OSCILLOSCOPE.</p> <p>1) Connect connectors to TCM and transmission.</p> <p>2) Set oscilloscope to TCM connector terminals.</p> <p>Positive probe; (B55) No. 8 Earth lead; (B55) No. 9</p> <p>3) Start the engine and move select lever to "P" or "N" range.</p>	Is the signal voltage more than AC 1 V?	Even if "POWER" indicator lights up, the circuit has returned to a normal condition at this time. A temporary poor contact of the connector or harness may be the cause. Repair harness or connector in the TCM and transmission.	Go to step 11.
11	<p>CHECK POOR CONTACT.</p>	Is there poor contact in torque converter turbine speed sensor circuit?	Repair poor contact.	Replace TCM. <Ref. to AT-48, Transmission Control Module (TCM).>

DIAGNOSTIC PROCEDURE WITH TROUBLE CODE

Automatic Transmission (Diagnostics)

MEMO:

DIAGNOSTIC PROCEDURE WITH TROUBLE CODE

Automatic Transmission (Diagnostics)

G: TROUBLE CODE 38 — TORQUE CONTROL SIGNAL — S004509D26

DIAGNOSIS:

- The signal circuit is open or shorted.

TROUBLE SYMPTOM:

Excessive shift shock.

WIRING DIAGRAM:

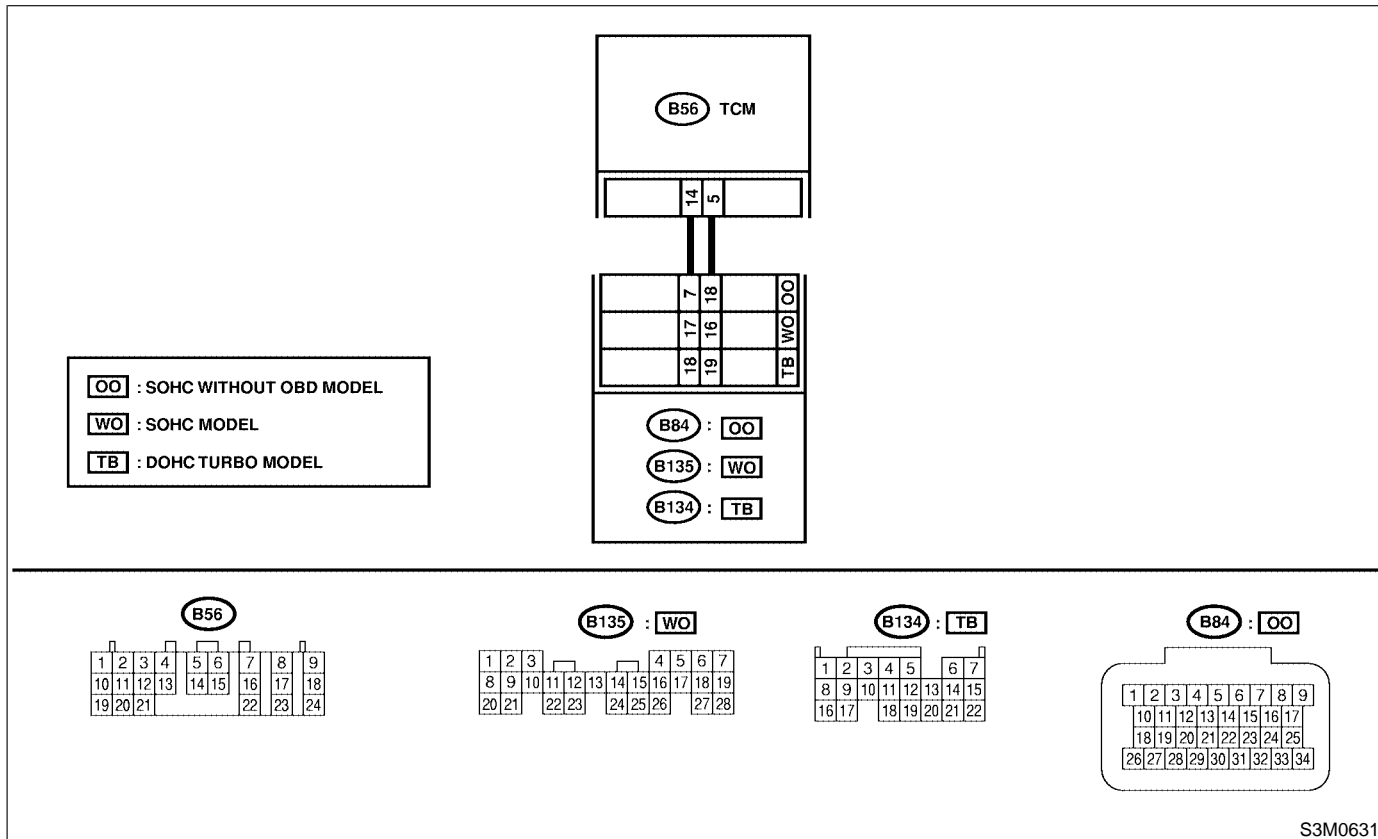

No.	Step	Check	Yes	No
1	<p>CHECK HARNESS CONNECTOR BETWEEN TCM AND ECM.</p> <p>1) Turn ignition switch to OFF.</p> <p>2) Disconnect connectors from TCM and ECM.</p> <p>3) Measure resistance of harness between TCM and ECM connector.</p> <p>Connector & terminal</p> <p>SOHC without OBD:</p> <p>(B56) No. 14 — (B84) No. 7:</p> <p>(B56) No. 5 — (B84) No. 18:</p> <p>SOHC:</p> <p>(B56) No. 14 — (B135) No. 17:</p> <p>(B56) No. 5 — (B135) No. 16:</p> <p>DOHC TURBO:</p> <p>(B56) No. 14 — (B134) No. 18:</p> <p>(B56) No. 5 — (B134) No. 19:</p>	Is the resistance less than 1 Ω?	Go to step 2.	Repair open circuit in harness between TCM and ECM connector.
2	<p>CHECK HARNESS CONNECTOR BETWEEN TCM AND ECM.</p> <p>Measure resistance of harness between TCM connector and chassis ground.</p> <p>Connector & terminal</p> <p>(B56) No. 14 — Chassis ground:</p> <p>(B56) No. 5 — Chassis ground:</p>	Is the resistance more than 1 MΩ?	Go to step 3.	Repair short circuit in harness between TCM and ECM connector.

DIAGNOSTIC PROCEDURE WITH TROUBLE CODE

Automatic Transmission (Diagnostics)

No.	Step	Check	Yes	No
3	CHECK OUTPUT SIGNAL EMITTED FROM TCM. 1) Connect connectors to TCM and ECM. 2) Turn ignition switch to ON (engine OFF). 3) Measure voltage between TCM connector terminals. Connector & terminal (B56) No. 14 (+) — Chassis ground (-): (B56) No. 5 (+) — Chassis ground (-):	Is the voltage more than 4.8 V?	Even if "POWER" indicator lights up, the circuit has returned to a normal condition at this time. A temporary poor contact of the connector or harness may be the cause. Repair harness or connector in the TCM and ECM.	Go to step 4.
4	CHECK POOR CONTACT.	Is there poor contact in torque control signal circuit?	Repair poor contact.	Go to step 5.
5	CHECK GROUND LINE BETWEEN TRANSMISSION AND BODY. Check installing condition of ground line in transmission and body.	Is there any dirt or rust at ground line installing point?	Remove dirt and rust.	Go to step 6.
6	CHECK GROUND LINE BETWEEN TRANSMISSION AND BODY. Check installing condition of ground line in transmission and body. Tightening torque: 13±3 N·m (1.3±0.3 kgf·m, 9.4±2.2 ft·lb)	Is tightening torque value within specification?	Go to step 7.	Tighten to specified torque.
7	CHECK GROUND LINE INSIDE TRANSMISSION. 1) Drain AT fluid and remove oil pan. 2) Check tightening torque value of ground line installing bolt. Tightening torque: T: 8±1 N·m (0.8±0.1 kgf·m, 5.8±0.7 ft·lb)	Is tightening torque value within specification?	Go to step 9.	Tighten to specified torque.
8	CHECK GROUND CIRCUIT OF ECM. <Ref. to AT-50, TROUBLE CODE 31 - THROTTLE POSITION SENSOR -, Diagnostic Procedure with Trouble Code.>	Is there any trouble?	Repair ground terminal and/or ground circuit of ECM.	Go to step 9.
9	RECHECK OUTPUT SIGNAL EMITTED FROM TCM. Measure voltage between TCM connector and chassis ground. Connector & terminal (B56) No. 14 (+) — Chassis ground (-): (B56) No. 5 (+) — Chassis ground (-):	Is each voltage more than 4.8 V?	Replace TCM. <Ref. to AT-48, Transmission Control Module (TCM).>	Replace ECM.

DIAGNOSTIC PROCEDURE WITH TROUBLE CODE

Automatic Transmission (Diagnostics)

H: TROUBLE CODE 45 — INTAKE MANIFOLD PRESSURE SIGNAL — S004509D48

DIAGNOSIS:

Input signal circuit of TCM from ECM is open or shorted.

TROUBLE SYMPTOM:

Excessive shift shock.

WIRING DIAGRAM:

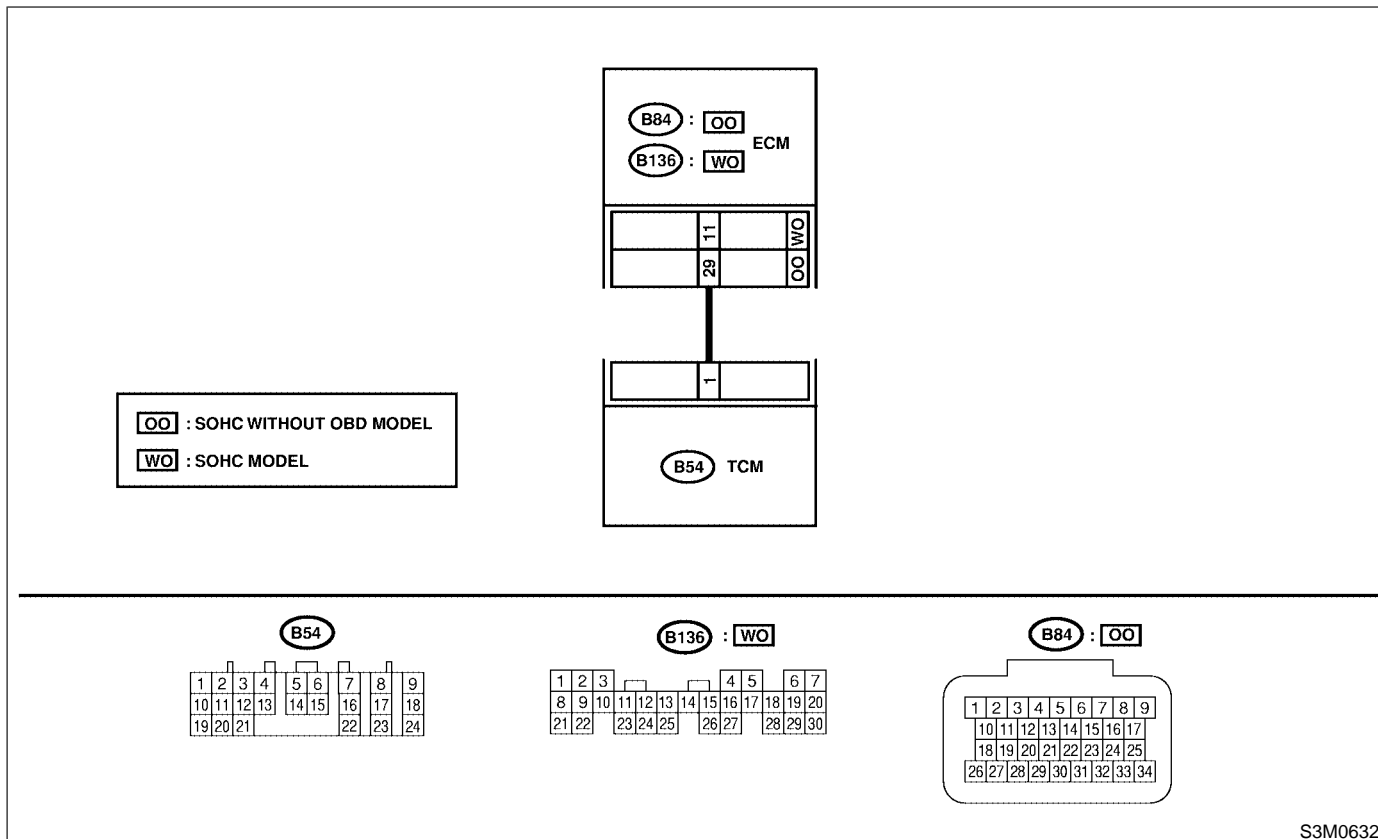

No.	Step	Check	Yes	No
1	CHECK ENGINE GROUND TERMINALS AND GROUND CIRCUIT OF ECM <Ref. to AT-50, TROUBLE CODE 31 - THROTTLE POSITION SENSOR -, Diagnostic Procedure with Trouble Code.>	Is there any trouble?	Repair ground terminal and/or ground circuit of ECM.	Go to step 2.
2	CHECK HARNESS CONNECTOR BETWEEN TCM AND ECM. 1) Turn ignition switch to OFF. 2) Disconnect connectors from TCM and ECM. 3) Measure resistance of harness between TCM and ECM connector. Connector & terminal SOHC without OBD: (B54) No. 1 — (B84) No. 29: SOHC: (B54) No. 1 — (B136) No. 11:	Is the resistance less than 1 Ω?	Go to step 3.	Repair open circuit in harness between TCM and ECM connector.
3	CHECK HARNESS CONNECTOR BETWEEN TCM AND ECM. Measure resistance of harness between TCM connector and chassis ground. Connector & terminal (B54) No. 1 — Chassis ground:	Is the resistance more than 1 MΩ?	Go to step 4.	Repair short circuit in harness between TCM and ECM connector.

DIAGNOSTIC PROCEDURE WITH TROUBLE CODE

Automatic Transmission (Diagnostics)

No.	Step	Check	Yes	No
4	PREPARE SUBARU SELECT MONITOR.	Do you have a Subaru Select Monitor?	Go to step 6.	Go to step 5.
5	CHECK INPUT SIGNAL FOR TCM. 1) Connect connectors to TCM and ECM. 2) Start the engine, and warm-up the transmission until ATF temperature is above 80°C (176°F). NOTE: If ambient temperature is below 0°C (32°F), drive the vehicle until the ATF reaches its operating temperature. 3) Engine idling. 4) Measure voltage between TCM connector and chassis ground. Connector & terminal (B54) No. 1 (+) — Chassis ground (-):	Is the voltage between 0.4 and 1.8 V?	Even if "POWER" indicator lights up, the circuit has returned to a normal condition at this time. A temporary poor contact of the connector or harness may be the cause. Repair harness or connector in the TCM and ECM.	Go to step 7.
6	CHECK INPUT SIGNAL FOR TCM USING SUBARU SELECT MONITOR. 1) Connect connectors to TCM and ECM. 2) Connect Subaru Select Monitor to data link connector. 3) Start the engine, and turn Subaru Select monitor switch to ON. 4) Warm-up the engine until engine coolant temperature is above 80°C (176°F). 5) Engine idling. 6) Read data of intake manifold pressure signal using Subaru Select Monitor. ● Display shows intake manifold pressure signal value sent from ECM.	Is the value between 0.4 and 1.8 V?	Even if "POWER" indicator lights up, the circuit has returned to a normal condition at this time. A temporary poor contact of the connector or harness may be the cause. Repair harness or connector in the TCM and ECM.	Go to step 7.
7	CHECK POOR CONTACT.	Is there poor contact in intake manifold pressure signal circuit?	Repair poor contact.	Replace TCM. <Ref. to AT-48, Transmission Control Module (TCM).>

DIAGNOSTIC PROCEDURE WITH TROUBLE CODE

Automatic Transmission (Diagnostics)

I: TROUBLE CODE 71 — SHIFT SOLENOID 1 — S004509D91

DIAGNOSIS:

Output signal circuit of shift solenoid 1 is open or shorted.

TROUBLE SYMPTOM:

Does not shift.

WIRING DIAGRAM:

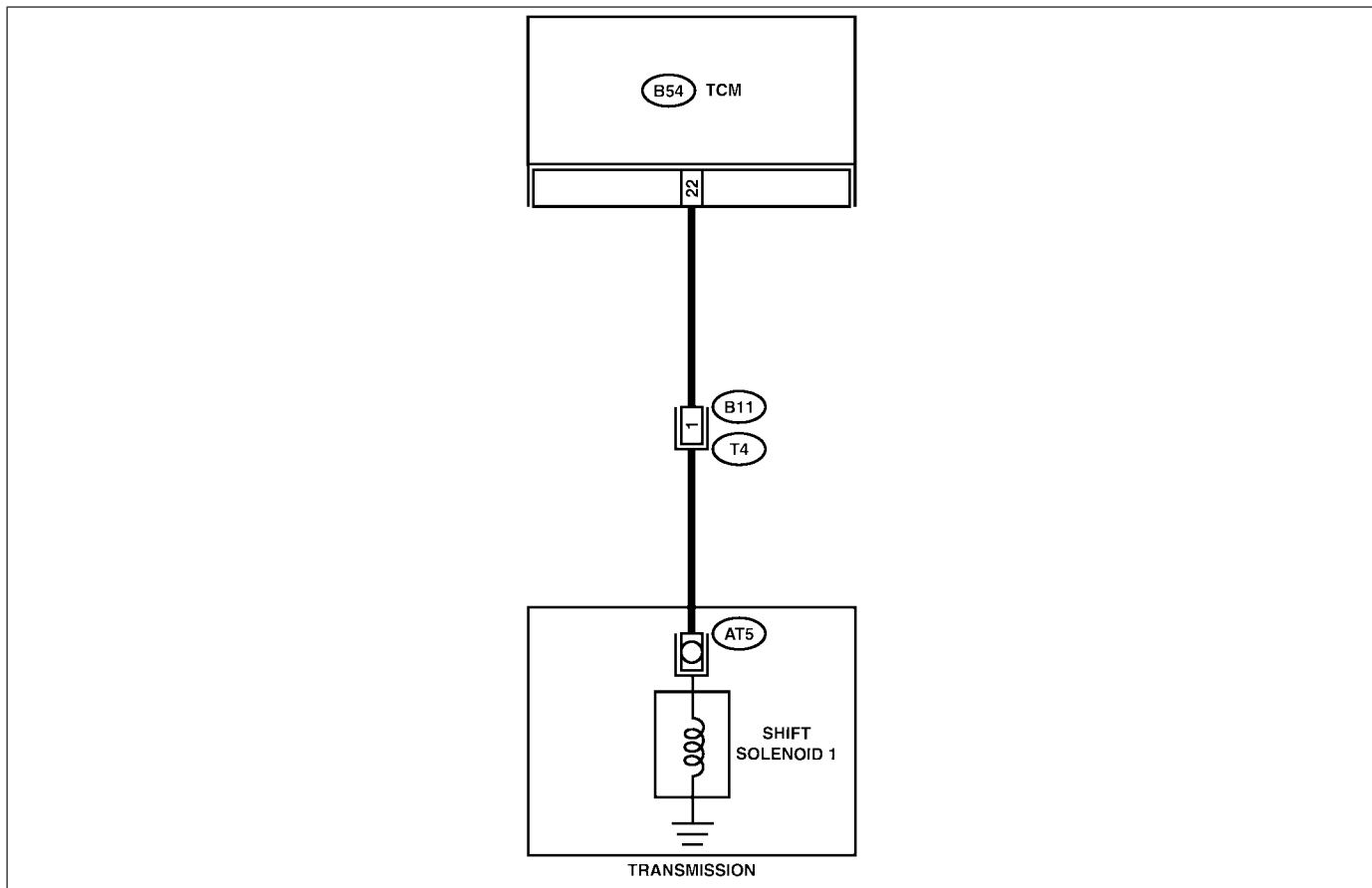

TR0410

No.	Step	Check	Yes	No
1	CHECK HARNESS CONNECTOR BETWEEN TCM AND TRANSMISSION. 1) Turn ignition switch to OFF. 2) Disconnect connector from TCM and transmission. 3) Measure resistance of harness between TCM and shift solenoid 1 connector. Connector & terminal (B54) No. 22 — (B11) No. 1:	Is the resistance less than 1 Ω?	Go to step 2.	Repair open circuit in harness between TCM and transmission connector.

DIAGNOSTIC PROCEDURE WITH TROUBLE CODE

Automatic Transmission (Diagnostics)

No.	Step	Check	Yes	No
2	CHECK HARNESS CONNECTOR BETWEEN TCM AND TRANSMISSION. Measure resistance of harness between TCM connector and chassis ground. <i>Connector & terminal</i> <i>(B54) No. 22 — Chassis ground:</i>	Is the resistance more than 1 M Ω ?	Go to step 3.	Repair short circuit in harness between TCM and transmission connector.
3	CHECK SHIFT SOLENOID 1. Measure resistance between transmission connector terminals. <i>Connector & terminal</i> <i>(T4) No. 1 — No. 16:</i>	Is the resistance between 10 and 16 Ω ?	Go to step 4.	Go to step 7.
4	CHECK OUTPUT SIGNAL EMITTED FROM TCM. 1) Connect connectors to TCM and transmission. 2) Turn ignition switch to ON (engine OFF). 3) Move select lever to "D" range. 4) Measure voltage between TCM connector and chassis ground. <i>Connector & terminal</i> <i>(B54) No. 22 (+) — Chassis ground (-):</i>	Is the voltage more than 9V?	Go to step 5.	Go to step 6.
5	CHECK OUTPUT SIGNAL EMITTED FROM TCM. 1) Hold switch to ON. 2) Measure voltage between TCM connector and chassis ground. <i>Connector & terminal</i> <i>(B54) No. 22 (+) — Chassis ground (-):</i>	Is the voltage less than 1V?	Even if "POWER" indicator lights up, the circuit has returned to a normal condition at this time. A temporary poor contact of the connector or harness may be the cause. Repair harness or contact in the TCM.	Go to step 6.
6	CHECK POOR CONTACT.	Is there poor contact in shift solenoid 1 circuit?	Repair poor contact.	Replace TCM. <Ref. to AT-48, Transmission Control Module (TCM).>
7	CHECK SHIFT SOLENOID 1 (IN TRANSMISSION). 1) Remove transmission connector from bracket. 2) Lift-up or raise the vehicle and support with safety stand. CAUTION: On AWD models, raise all wheels off ground. 3) Drain automatic transmission fluid. CAUTION: Do not drain the automatic transmission fluid until it cools down. 4) Remove oil pan, and disconnect connector from shift solenoid 1. 5) Measure resistance between shift solenoid 1 connector and transmission ground. <i>Terminal</i> <i>No. 1 — Transmission ground:</i>	Is the resistance between 10 and 16 Ω ?	Go to step 8.	Replace shift solenoid 1. <Ref. to AT-48, Transmission Control Module (TCM).>

DIAGNOSTIC PROCEDURE WITH TROUBLE CODE

Automatic Transmission (Diagnostics)

No.	Step	Check	Yes	No
8	CHECK HARNESS CONNECTOR BETWEEN SHIFT SOLENOID 1 AND TRANSMISSION. Measure resistance of harness between shift solenoid 1 and transmission connector. Connector & terminal (AT5) No. 1 — (T4) No. 1:	Is the resistance less than 1 Ω ?	Go to step 9.	Repair open circuit in harness between shift solenoid 1 and transmission connector.
9	CHECK HARNESS CONNECTOR BETWEEN SHIFT SOLENOID 1 AND TRANSMISSION. Measure resistance of harness between shift solenoid 1 connector and transmission ground. Connector & terminal (T4) No. 1 — Transmission ground:	Is the resistance more than 1 M Ω ?	Even if "POWER" indicator lights up, the circuit has returned to a normal condition at this time. A temporary poor contact of the connector or harness may be the cause. Repair harness or connector in shift solenoid 1 and transmission.	Repair short circuit harness between shift solenoid 1 and transmission connector.

DIAGNOSTIC PROCEDURE WITH TROUBLE CODE

Automatic Transmission (Diagnostics)

MEMO:

DIAGNOSTIC PROCEDURE WITH TROUBLE CODE

Automatic Transmission (Diagnostics)

J: TROUBLE CODE 72 — SHIFT SOLENOID 2 — S004509D98

DIAGNOSIS:

Output signal circuit of shift solenoid 2 is open or shorted.

TROUBLE SYMPTOM:

Does not shift.

WIRING DIAGRAM:

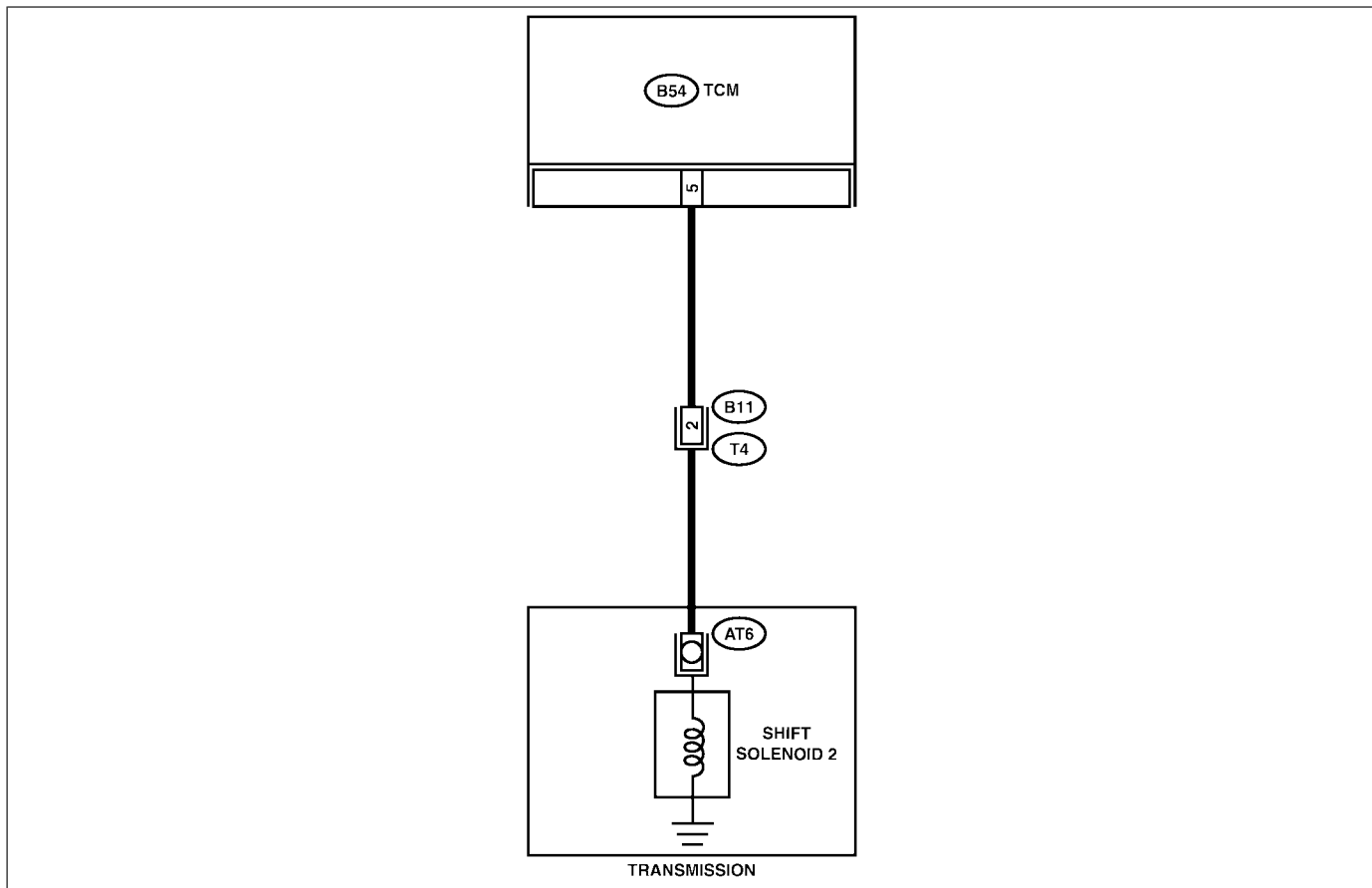

TR0411

No.	Step	Check	Yes	No
1	<p>CHECK HARNESS CONNECTOR BETWEEN TCM AND TRANSMISSION.</p> <p>1) Turn ignition switch to OFF.</p> <p>2) Disconnect connector from TCM and transmission.</p> <p>3) Measure resistance of harness between TCM and shift solenoid 2 connector.</p> <p>Connector & terminal (B54) No. 5 — (B11) No. 2:</p>	Is the resistance less than 1 Ω?	Go to step 2.	Repair open circuit in harness between TCM and transmission connector.

DIAGNOSTIC PROCEDURE WITH TROUBLE CODE

Automatic Transmission (Diagnostics)

No.	Step	Check	Yes	No
2	<p>CHECK HARNESS CONNECTOR BETWEEN TCM AND TRANSMISSION. Measure resistance of harness between TCM connector and transmission ground. Connector & terminal (B54) No. 5 — Transmission ground:</p>	Is the resistance more than 1 M Ω ?	Go to step 3.	Repair short circuit in harness between TCM and transmission connector.
3	<p>CHECK SHIFT SOLENOID 2. Measure resistance between transmission connector terminals. Connector & terminal (T4) No. 2 — No. 16:</p>	Is the resistance between 10 and 16 Ω ?	Go to step 4.	Go to step 6.
4	<p>CHECK OUTPUT SIGNAL EMITTED FROM TCM. 1) Connect connectors to TCM and transmission. 2) Lift-up or raise the vehicle and support with safety stand. CAUTION: On AWD models, raise all wheels off ground. 3) Start the engine and warm-up the transmission until ATF temperature is above 80°C (176°F). NOTE: If ambient temperature is below 0°C (32°F), drive the vehicle until the ATF reaches its operating temperature. 4) Move selector lever to "D", and slowly increase vehicle speed to 50 km/h (31 MPH). NOTE: The speed difference between front and rear wheels may light the ABS warning light, but this indicates no malfunction. When AT control diagnosis is finished, perform the ABS memory clearance procedure of on-board diagnostics system. <Ref. to ABS-22, Clear Memory Mode.> 5) Measure voltage between TCM connector and chassis ground. Connector & terminal (B54) No. 22 (+) — Chassis ground (-):</p>	Is the voltage less than 1 V?	Even if "POWER" indicator lights up, the circuit has returned to a normal condition at this time. A temporary poor contact of the connector or harness may be the cause. Repair harness or connector in the TCM and transmission.	Go to step 5.
5	<p>CHECK POOR CONTACT.</p>	Is there poor contact in shift solenoid 2 circuit?	Repair poor contact.	Replace TCM. <Ref. to AT-48, Transmission Control Module (TCM).>
6	<p>CHECK SHIFT SOLENOID 2 (IN TRANSMISSION). 1) Remove transmission connector from bracket. 2) Drain automatic transmission fluid. CAUTION: Do not drain the automatic transmission fluid until it cools down. 3) Remove oil pan, and disconnect connector from shift solenoid 2. 4) Measure resistance between shift solenoid 2 connector and transmission ground. Connector & terminal No. 1 — Transmission ground:</p>	Is the resistance between 10 and 16 Ω ?	Go to step 7.	Replace shift solenoid 2 assembly. <Ref. to AT-41, Shift Solenoids, Duty Solenoids and ATF Temperature Sensor.>

DIAGNOSTIC PROCEDURE WITH TROUBLE CODE

Automatic Transmission (Diagnostics)

No.	Step	Check	Yes	No
7	CHECK HARNESS CONNECTOR BETWEEN SHIFT SOLENOID 2 AND TRANSMISSION. Measure resistance of harness between shift solenoid 2 and transmission connector. Connector & terminal (AT6) No. 1 — (T4) No. 2:	Is the resistance less than 1 Ω ?	Go to step 8.	Repair open circuit in harness between shift solenoid 2 and transmission connector.
8	CHECK HARNESS CONNECTOR BETWEEN SHIFT SOLENOID 2 AND TRANSMISSION. Measure resistance of harness between shift solenoid 2 connector and transmission ground. Connector & terminal (T4) No. 2 — Transmission ground:	Is the resistance more than 1 M Ω ?	Even if "POWER" indicator lights up, the circuit has returned to a normal condition at this time. A temporary poor contact of the connector or harness may be the cause. Repair harness or connector in shift solenoid 2 and transmission.	Repair short circuit harness between shift solenoid 2 and transmission connector.

DIAGNOSTIC PROCEDURE WITH TROUBLE CODE

Automatic Transmission (Diagnostics)

MEMO:

DIAGNOSTIC PROCEDURE WITH TROUBLE CODE

Automatic Transmission (Diagnostics)

K: TROUBLE CODE 73 — LOW CLUTCH TIMING SOLENOID — S004509E05

DIAGNOSIS:

Output signal circuit of low clutch timing solenoid is open or shorted.

TROUBLE SYMPTOM:

Excessive shift shock.

WIRING DIAGRAM:

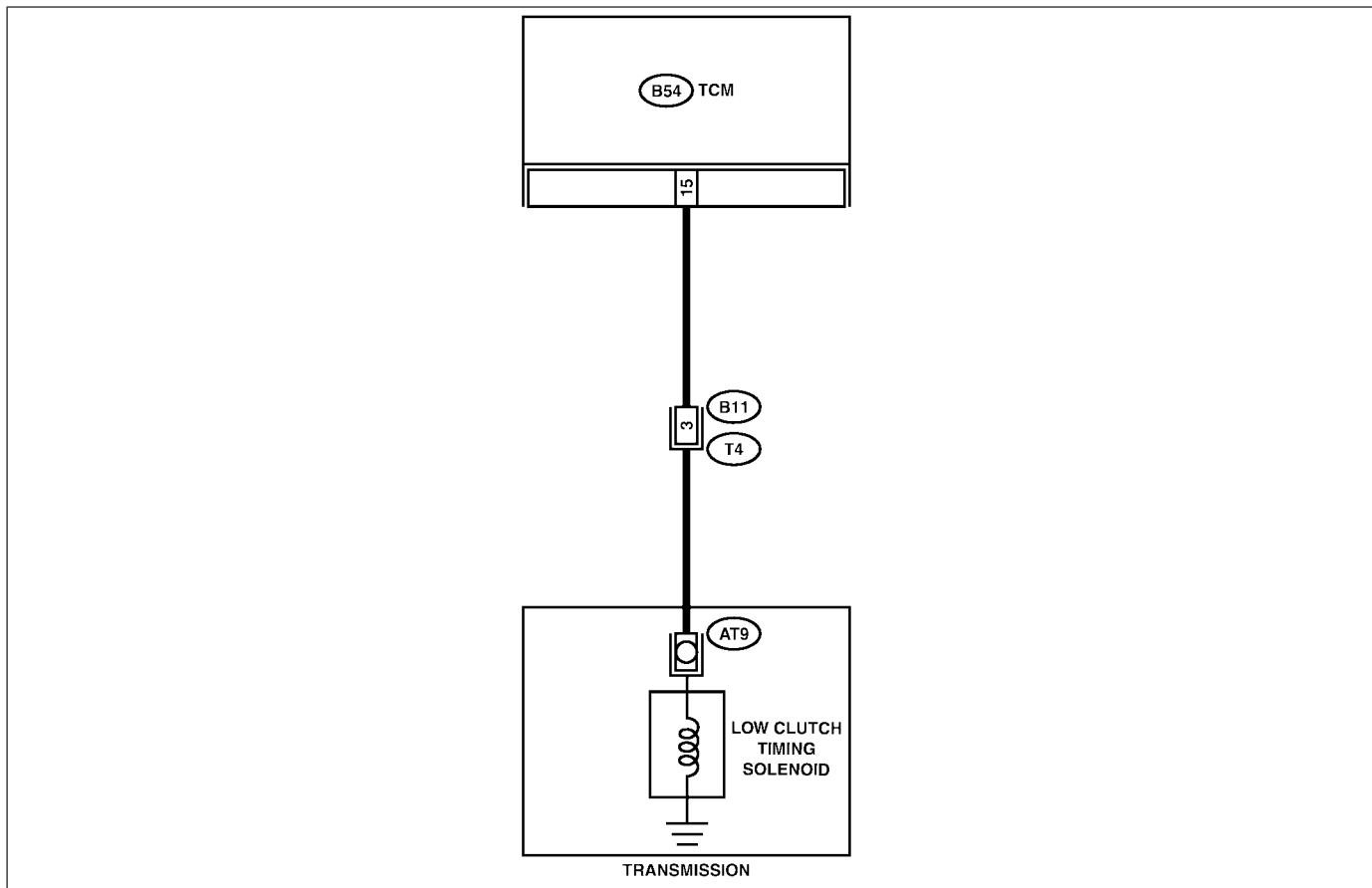

TR0412

No.	Step	Check	Yes	No
1	<p>CHECK HARNESS CONNECTOR BETWEEN TCM AND TRANSMISSION.</p> <p>1) Turn ignition switch to OFF.</p> <p>2) Disconnect connector from TCM and transmission.</p> <p>3) Measure resistance of harness between TCM and transmission connector.</p> <p>Connector & terminal (B54) No. 15 — (B11) No. 3:</p>	Is the resistance less than 1 Ω?	Go to step 2.	Repair open circuit in harness between TCM and transmission connector.

DIAGNOSTIC PROCEDURE WITH TROUBLE CODE

Automatic Transmission (Diagnostics)

No.	Step	Check	Yes	No
2	CHECK HARNESS CONNECTOR BETWEEN TCM AND TRANSMISSION. Measure resistance of harness between TCM connector and transmission ground. <i>Connector & terminal</i> <i>(B54) No. 15 — Chassis ground:</i>	Is the resistance more than 1 M Ω ?	Go to step 3.	Repair short circuit in harness between TCM and transmission connector.
3	CHECK LOW CLUTCH TIMING SOLENOID. Measure resistance between transmission connector terminals. <i>Connector & terminal</i> <i>(T4) No. 3 — No. 16:</i>	Is the resistance between 10 and 16 Ω ?	Go to step 4.	Go to step 7.
4	CHECK OUTPUT SIGNAL EMITTED FROM TCM. 1) Connect connectors to TCM and transmission. 2) Turn ignition switch to ON (engine OFF). 3) Move select lever to "D" range. 4) Measure voltage between TCM connector and chassis ground. <i>Connector & terminal</i> <i>(B54) No. 15 (+) — Chassis ground (-):</i>	Is the voltage more than 9V?	Go to step 5.	Go to step 6.
5	CHECK OUTPUT SIGNAL EMITTED FROM TCM. 1) Hold switch to ON. 2) Measure voltage between TCM connector and chassis ground. <i>Connector & terminal</i> <i>(B54) No. 15 (+) — Chassis ground (-):</i>	Is the voltage less than 1V?	Even if "POWER" indicator lights up, the circuit has returned to a normal condition at this time. A temporary poor contact of the connector or harness may be the cause. Repair harness or contact in the TCM and transmission.	Go to step 6.
6	CHECK POOR CONTACT.	Is there poor contact in low clutch timing solenoid circuit?	Repair poor contact.	Replace TCM. <Ref. to AT-48, Transmission Control Module (TCM).>
7	CHECK LOW CLUTCH TIMING SOLENOID (IN TRANSMISSION). 1) Remove transmission connector from bracket. 2) Lift-up or raise the vehicle and support with safety stand. CAUTION: On AWD models, raise all wheels off ground. 3) Drain automatic transmission fluid. CAUTION: Do not drain the automatic transmission fluid until it cools down. 4) Remove oil pan, and disconnect connector from low clutch timing solenoid. 5) Measure resistance between low clutch timing solenoid connector and transmission ground. <i>Terminal</i> <i>No. 1 — Transmission ground:</i>	Is the resistance between 10 and 16 Ω ?	Go to step 8.	Replace low clutch timing solenoid. <Ref. to AT-41, Shift Solenoids, Duty Solenoids and ATF Temperature Sensor.>

DIAGNOSTIC PROCEDURE WITH TROUBLE CODE

Automatic Transmission (Diagnostics)

No.	Step	Check	Yes	No
8	<p>CHECK HARNESS CONNECTOR BETWEEN LOW CLUTCH TIMING SOLENOID AND TRANSMISSION.</p> <p>Measure resistance of harness between low clutch timing solenoid and transmission connector.</p> <p>Connector & terminal (AT9) No. 1 — (T4) No. 3:</p>	Is the resistance less than 1 Ω ?	Go to step 9.	Repair open circuit in harness between low clutch timing solenoid and transmission connector.
9	<p>CHECK HARNESS CONNECTOR BETWEEN LOW CLUTCH TIMING SOLENOID AND TRANSMISSION.</p> <p>Measure resistance of harness between low clutch timing solenoid connector and transmission ground.</p> <p>Connector & terminal (T4) No. 3 — Transmission ground:</p>	Is the resistance more than 1 M Ω ?	Even if "POWER" indicator lights up, the circuit has returned to a normal condition at this time. A temporary poor contact of the connector or harness may be the cause. Repair harness or connector in low clutch timing solenoid and transmission.	Repair short circuit harness between low clutch timing solenoid and transmission connector.

DIAGNOSTIC PROCEDURE WITH TROUBLE CODE

Automatic Transmission (Diagnostics)

MEMO:

DIAGNOSTIC PROCEDURE WITH TROUBLE CODE

Automatic Transmission (Diagnostics)

L: TROUBLE CODE 74 — 2-4 BRAKE TIMING SOLENOID — S004509E07

DIAGNOSIS:

Output signal circuit of 2-4 brake timing solenoid is open or shorted.

TROUBLE SYMPTOM:

Excessive shift shock.

WIRING DIAGRAM:

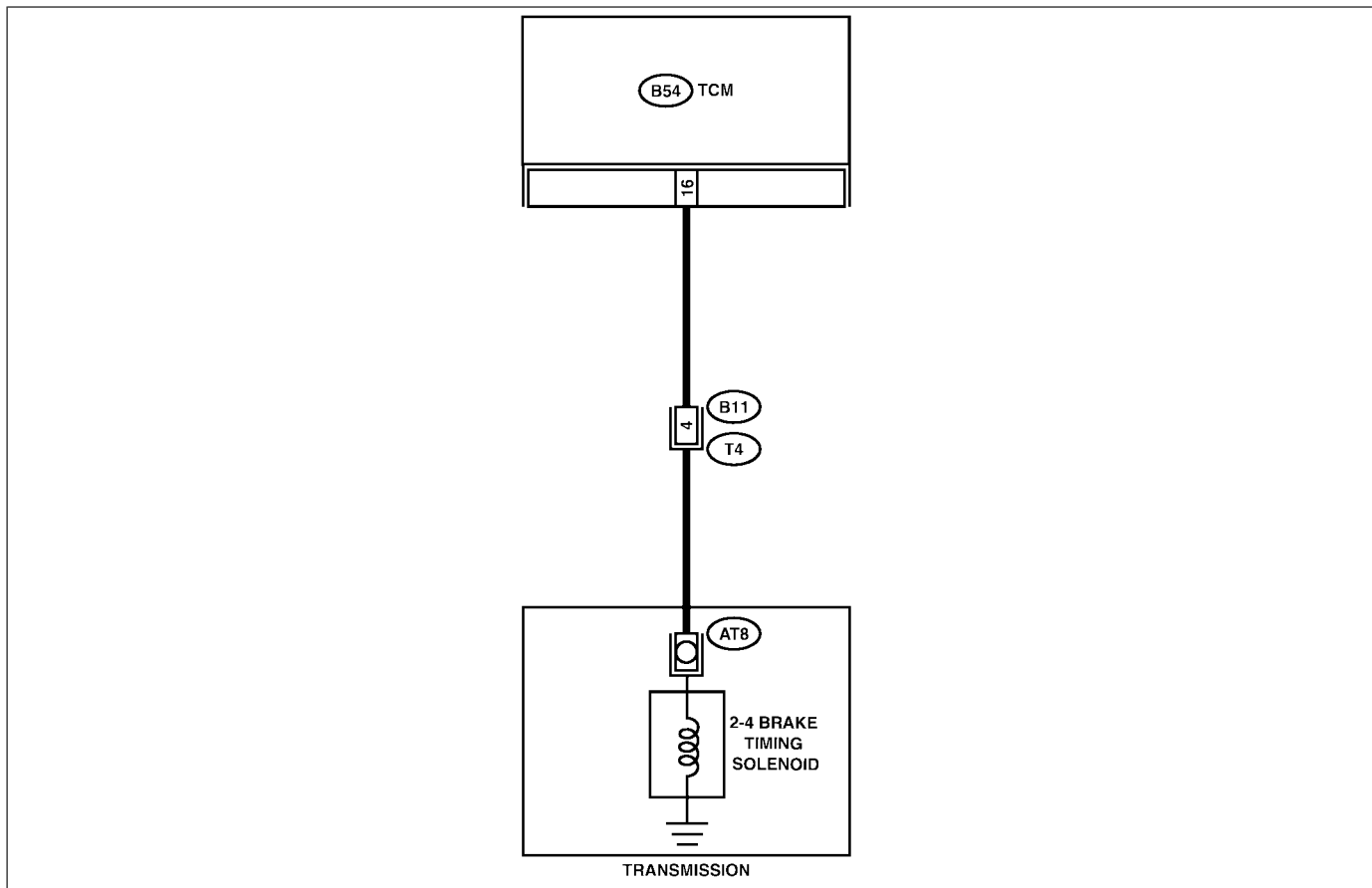

TR0413

No.	Step	Check	Yes	No
1	<p>CHECK HARNESS CONNECTOR BETWEEN TCM AND TRANSMISSION.</p> <p>1) Turn ignition switch to OFF.</p> <p>2) Disconnect connector from TCM and transmission.</p> <p>3) Measure resistance of harness between TCM and transmission connector.</p> <p>Connector & terminal (B54) No. 16 — (B11) No. 4:</p>	Is the resistance less than 1 Ω?	Go to step 2.	Repair open circuit in harness between TCM and transmission connector.

DIAGNOSTIC PROCEDURE WITH TROUBLE CODE

Automatic Transmission (Diagnostics)

No.	Step	Check	Yes	No
2	<p>CHECK HARNESS CONNECTOR BETWEEN TCM AND TRANSMISSION. Measure resistance of harness between TCM connector and transmission ground. Connector & terminal (B54) No. 16 — Chassis ground:</p>	Is the resistance more than 1 M Ω ?	Go to step 3.	Repair short circuit in harness between TCM and transmission connector.
3	<p>CHECK 2-4 BRAKE TIMING SOLENOID. Measure resistance between transmission connector terminals. Connector & terminal (T4) No. 4 — No. 16:</p>	Is the resistance between 10 and 16 Ω ?	Go to step 4.	Go to step 7.
4	<p>CHECK OUTPUT SIGNAL EMITTED FROM TCM. 1) Connect connectors to TCM and transmission. 2) Lift-up or raise the vehicle and support with safety stand. CAUTION: On AWD models, raise all wheels off ground. 3) Start the engine and warm-up the transmission until ATF temperature is above 80°C (176°F). NOTE: If ambient temperature is below 0°C (32°F), drive the vehicle until the ATF reaches its operating temperature. 4) Move selector lever to "1", and slowly increase vehicle speed to 10 km/h (6 MPH). NOTE: The speed difference between front and rear wheels may light the ABS warning light, but this indicates no malfunction. When AT control diagnosis is finished, perform the ABS memory clearance procedure of on-board diagnostics system. <Ref. to ABS-22, Clear Memory Mode.> 5) Measure voltage between TCM connector and chassis ground. Connector & terminal (B54) No. 16 (+) — Chassis ground (-):</p>	Is the voltage less than 1 V?	Go to step 5.	Go to step 6.
5	<p>CHECK OUTPUT SIGNAL EMITTED FROM TCM. 1) Move selector lever to "D", and slowly increase vehicle speed to 65 km/h (40 MPH). NOTE: The speed difference between front and rear wheels may light the ABS warning light, but this indicates no malfunction. When AT control diagnosis is finished, perform the ABS memory clearance procedure of on-board diagnostics system. <Ref. to ABS-22, Clear Memory Mode.> 2) Measure voltage between TCM connector and chassis ground. Connector & terminal (B54) No. 16 (+) — Chassis ground (-):</p>	Is the voltage more than 9 V?	Even if "POWER" indicator lights up, the circuit has returned to a normal condition at this time. A temporary poor contact of the connector or harness may be the cause. Repair harness or contact in the transmission.	Go to step 6.

DIAGNOSTIC PROCEDURE WITH TROUBLE CODE

Automatic Transmission (Diagnostics)

No.	Step	Check	Yes	No
6	CHECK POOR CONTACT.	Is there poor contact in 2-4 brake timing solenoid circuit?	Repair poor contact.	Replace TCM. <Ref. to AT-48, Transmission Control Module (TCM).>
7	CHECK 2-4 BRAKE TIMING SOLENOID (IN TRANSMISSION). 1) Remove transmission connector from bracket. 2) Lift-up or raise the vehicle and support with safety stand. CAUTION: On AWD models, raise all wheels off ground. 3) Drain automatic transmission fluid. CAUTION: Do not drain the automatic transmission fluid until it cools down. 4) Remove oil pan, and disconnect connector from 2-4 brake timing solenoid. 5) Measure resistance between 2-4 brake timing solenoid connector and transmission ground. <i>Terminal</i> No. 1 — Transmission ground:	Is the resistance between 10 and 16 Ω?	Go to step 8.	Replace 2-4 brake timing solenoid. <Ref. to AT-41, Shift Solenoids, Duty Solenoids and ATF Temperature Sensor.>
8	CHECK HARNESS CONNECTOR BETWEEN 2-4 BRAKE TIMING SOLENOID AND TRANSMISSION. Measure resistance of harness between 2-4 brake timing solenoid and transmission connector. <i>Connector & terminal</i> (AT8) No. 1 — (T4) No. 4:	Is the resistance less than 1 Ω?	Go to step 9.	Repair open circuit in harness between 2-4 brake timing solenoid and transmission connector.
9	CHECK HARNESS CONNECTOR BETWEEN 2-4 BRAKE TIMING SOLENOID AND TRANSMISSION. Measure resistance of harness between 2-4 brake timing solenoid connector and transmission ground. <i>Connector & terminal</i> (T4) No. 4 — Transmission ground:	Is the resistance more than 1 MΩ?	Even if "POWER" indicator lights up, the circuit has returned to a normal condition at this time. A temporary poor contact of the connector or harness may be the cause. Repair harness or connector in 2-4 brake timing solenoid and transmission.	Repair short circuit harness between 2-4 brake timing solenoid and transmission connector.

DIAGNOSTIC PROCEDURE WITH TROUBLE CODE

Automatic Transmission (Diagnostics)

MEMO:

DIAGNOSTIC PROCEDURE WITH TROUBLE CODE

Automatic Transmission (Diagnostics)

M: TROUBLE CODE 75 — LINE PRESSURE DUTY SOLENOID — S004509E14

DIAGNOSIS:

Output signal circuit of line pressure duty solenoid is open or shorted.

TROUBLE SYMPTOM:

Excessive shift shock.

WIRING DIAGRAM:

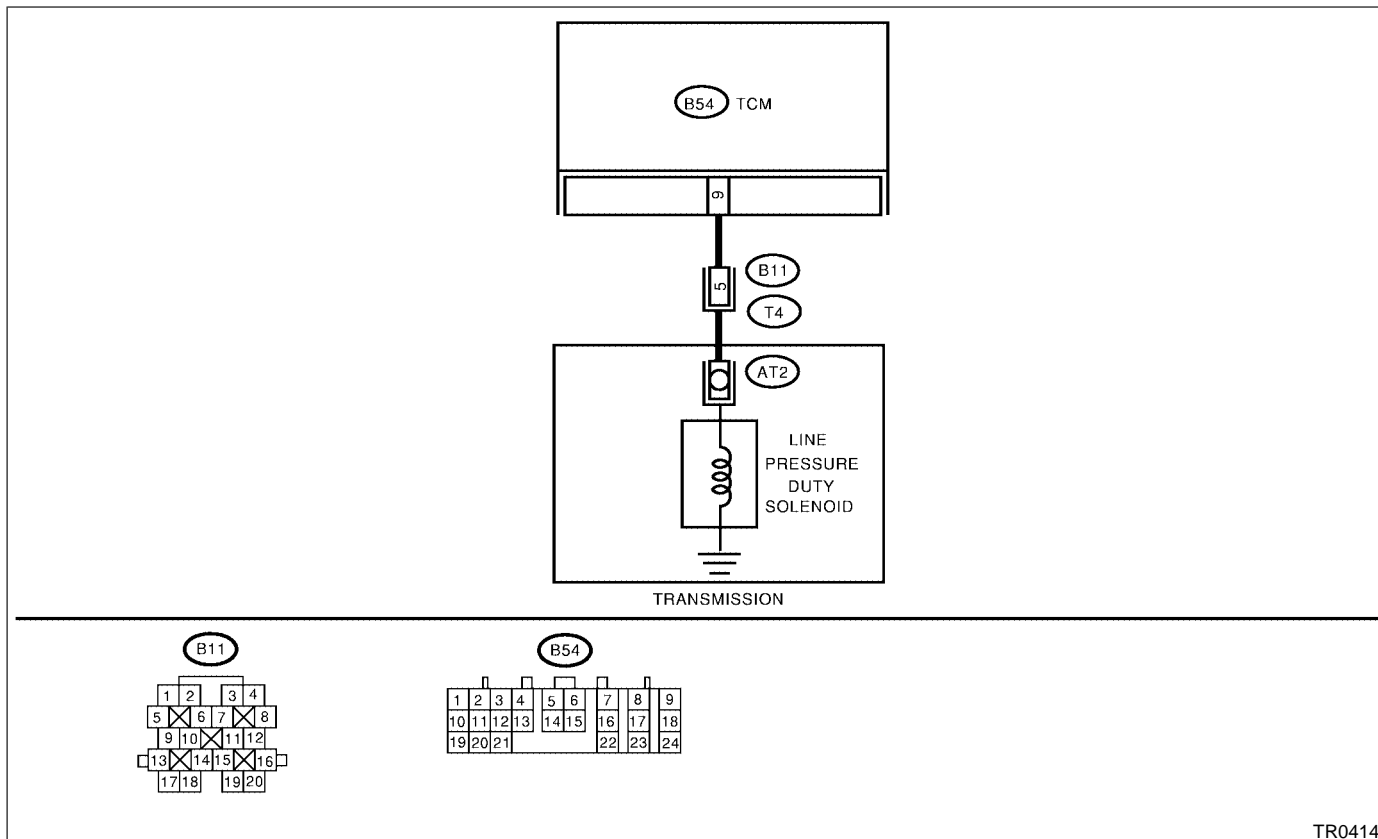

TR0414

No.	Step	Check	Yes	No
1	<p>CHECK HARNESS CONNECTOR BETWEEN TCM AND TRANSMISSION.</p> <p>1) Turn ignition switch to OFF.</p> <p>2) Disconnect connector from transmission and TCM.</p> <p>3) Measure resistance of harness between TCM and transmission connector.</p> <p>Connector & terminal (B54) No. 9 — (B11) No. 5:</p>	Is the resistance less than 1 Ω?	Go to step 2.	Repair open circuit in harness between TCM and transmission connector.
2	<p>CHECK HARNESS CONNECTOR BETWEEN TCM AND CHASSIS GROUND.</p> <p>Measure resistance of harness between TCM and chassis ground.</p> <p>Connector & terminal (B54) No. 9 — Chassis ground:</p>	Is the resistance more than 1 MΩ?	Go to step 3.	Repair short circuit in harness between TCM and transmission connector.
3	<p>CHECK LINE PRESSURE DUTY SOLENOID.</p> <p>Measure resistance between transmission connector receptacle's terminals.</p> <p>Terminal (T4) No. 5 — No. 16:</p>	Is the resistance between 2.0 and 4.5 Ω?	Go to step 4.	Go to step 10.
4	<p>PREPARE SUBARU SELECT MONITOR.</p>	Do you have a Subaru Select Monitor?	Go to step 7.	Go to step 5.

DIAGNOSTIC PROCEDURE WITH TROUBLE CODE

Automatic Transmission (Diagnostics)

No.	Step	Check	Yes	No
5	<p>CHECK OUTPUT SIGNAL EMITTED FROM TCM.</p> <p>1) Connect all connectors.</p> <p>2) Start the engine and warm-up the transmission until ATF temperature is above 80°C (176°F).</p> <p>NOTE: If ambient temperature is below 0°C (32°F), drive the vehicle until the ATF reaches its operating temperature.</p> <p>3) Turn ignition switch to ON (engine OFF).</p> <p>4) Move select lever to "N".</p> <p>5) Measure voltage between TCM connector and chassis ground.</p> <p>Connector & terminal (B54) No. 9 (+) — Chassis ground (-):</p>	Is the voltage between 1.5 and 5.0 V with throttle fully closed?	Go to step 6.	Go to step 9.
6	<p>CHECK OUTPUT SIGNAL EMITTED FROM TCM.</p> <p>Measure voltage between TCM connector and chassis ground.</p> <p>Connector & terminal (B54) No. 9 (+) — Chassis ground (-):</p>	Is the voltage less than 1 V with throttle fully open?	Even if "POWER" indicator lights up, the circuit has returned to a normal condition at this time. A temporary poor contact of the connector or harness may be the cause. Repair harness or connector in transmission.	Go to step 9.
7	<p>CHECK OUTPUT SIGNAL EMITTED FROM TCM USING SUBARU SELECT MONITOR.</p> <p>1) Connect connectors to TCM and transmission.</p> <p>2) Connect Subaru Select Monitor to data link connector.</p> <p>3) Start the engine, and turn Subaru Select Monitor switch to ON.</p> <p>4) Warm-up the transmission until ATF temperature is above 80°C (176°F).</p> <p>NOTE: If ambient temperature is below 0°C (32°F), drive the vehicle until the ATF reaches its operating temperature.</p> <p>5) Stop the engine and turn ignition switch to ON (engine OFF).</p> <p>6) Move select lever to "N".</p> <p>7) Read data of line pressure duty solenoid using Subaru Select Monitor.</p> <p>● Line pressure duty solenoid is indicated in "%".</p> <p>8) Throttle is fully closed.</p>	Is the value 100%?	Go to step 8.	Go to step 9.

DIAGNOSTIC PROCEDURE WITH TROUBLE CODE

Automatic Transmission (Diagnostics)

No.	Step	Check	Yes	No
8	CHECK OUTPUT SIGNAL EMITTED FROM TCM USING SUBARU SELECT MONITOR. 1) Turn ignition switch to ON (Engine OFF). 2) Throttle is fully open.	Is the value less than 25%?	Even if "POWER" indicator lights up, the circuit has returned to a normal condition at this time. A temporary poor contact of the connector or harness may be the cause. Repair harness or connector in transmission.	Go to step 9.
9	CHECK POOR CONTACT.	Is there poor contact in line pressure duty solenoid circuit?	Repair poor contact.	Replace TCM. <Ref. to AT-48, Transmission Control Module (TCM).>
10	CHECK LINE PRESSURE DUTY SOLENOID (IN TRANSMISSION). 1) Remove transmission connector from bracket. 2) Drain automatic transmission fluid. CAUTION: Do not drain the automatic transmission fluid until it cools down. 3) Remove oil pan, and disconnect connector from line pressure duty solenoid. 4) Measure resistance between line pressure duty solenoid connector and transmission ground. <i>Terminal</i> No. 1 — Transmission ground:	Is the resistance between 2.0 and 4.5 Ω ?	Go to step 11.	Replace line pressure duty solenoid. <Ref. to AT-41, Shift Solenoids, Duty Solenoids and ATF Temperature Sensor.>
11	CHECK HARNESS CONNECTOR BETWEEN TRANSMISSION AND LINE PRESSURE DUTY SOLENOID. Measure resistance of harness between line pressure duty solenoid and transmission connector. <i>Connector & terminal</i> (T4) No. 5 — (AT2) No. 1:	Is the resistance less than 1 Ω ?	Go to step 12.	Repair open circuit in harness between line pressure duty solenoid and transmission connector.
12	CHECK HARNESS CONNECTOR BETWEEN TRANSMISSION AND LINE PRESSURE DUTY SOLENOID. Measure resistance of harness between transmission connector and transmission ground. <i>Connector & terminal</i> (T4) No. 5 — Transmission ground:	Is the resistance more than 1 M Ω ?	Even if "POWER" indicator lights up, the circuit has returned to a normal condition at this time. A temporary poor contact of the connector or harness may be the cause. Repair harness or connector in line pressure duty solenoid and transmission.	Repair short circuit in harness between line pressure duty solenoid and transmission connector.

DIAGNOSTIC PROCEDURE WITH TROUBLE CODE

Automatic Transmission (Diagnostics)

MEMO:

DIAGNOSTIC PROCEDURE WITH TROUBLE CODE

Automatic Transmission (Diagnostics)

N: TROUBLE CODE 76 — 2-4 BRAKE DUTY SOLENOID — S004509E15

DIAGNOSIS:

Output signal circuit of 2-4 brake duty solenoid is open or shorted.

TROUBLE SYMPTOM:

Excessive shift shock.

WIRING DIAGRAM:

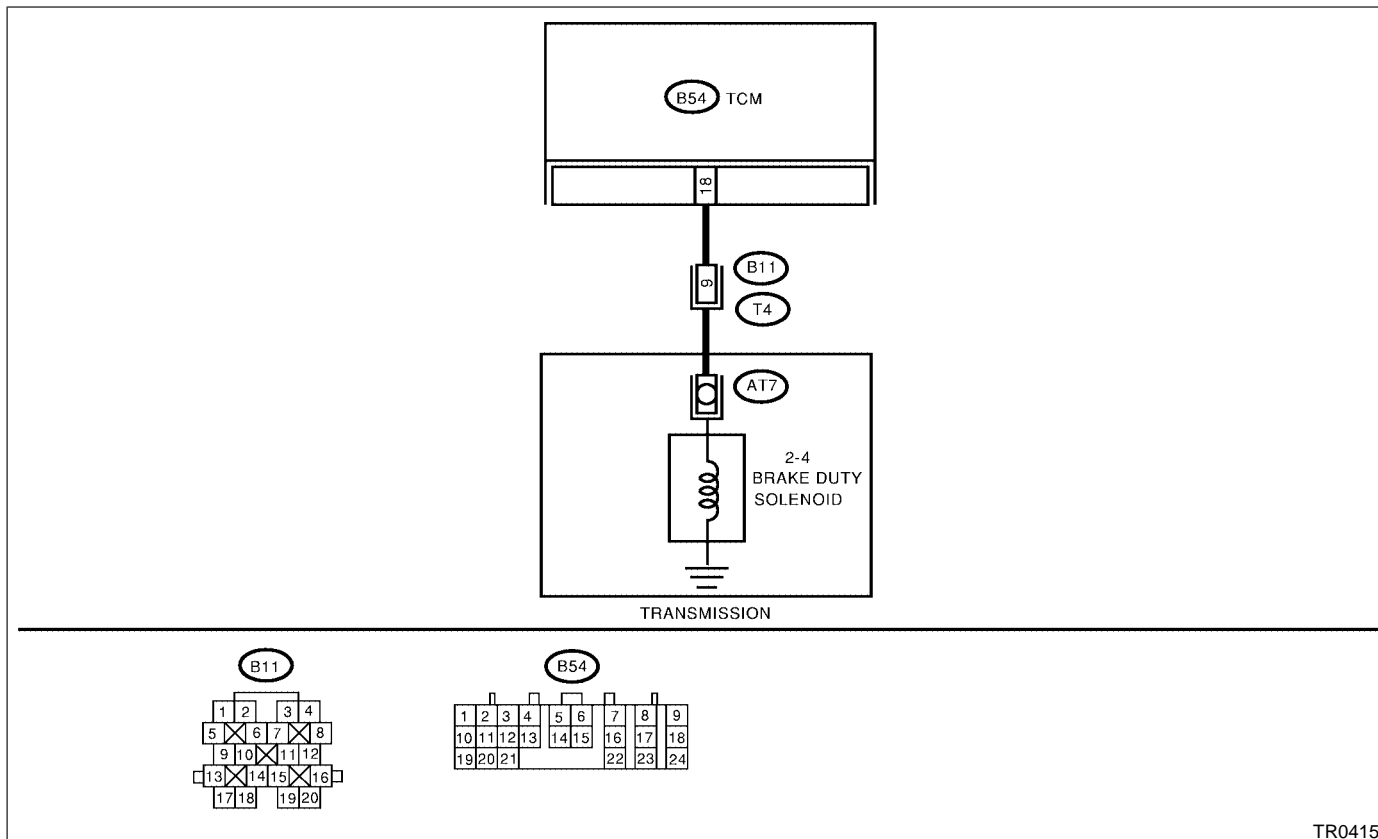

TR0415

No.	Step	Check	Yes	No
1	<p>CHECK HARNESS CONNECTOR BETWEEN TCM AND TRANSMISSION. 1) Turn ignition switch to OFF. 2) Disconnect connector from transmission and TCM. 3) Measure resistance of harness between TCM and transmission connector. <i>Connector & terminal</i> <i>(B54) No. 18 — (B11) No. 9:</i></p>	Is the resistance less than 1 Ω?	Go to step 2.	Repair open circuit in harness between TCM and transmission connector.
2	<p>CHECK HARNESS CONNECTOR BETWEEN TCM AND CHASSIS GROUND. Measure resistance of harness between TCM and chassis ground. <i>Connector & terminal</i> <i>(B54) No. 18 — Chassis ground:</i></p>	Is the resistance more than 1 MΩ?	Go to step 3.	Repair short circuit in harness between TCM and transmission connector.
3	<p>CHECK 2-4 BRAKE DUTY SOLENOID. Measure resistance between transmission connector receptacle's terminals. <i>Terminal</i> <i>(T4) No. 16 — No. 9:</i></p>	Is the resistance between 2.0 and 4.5 Ω?	Go to step 4.	Go to step 10.
4	<p>PREPARE SUBARU SELECT MONITOR.</p>	Do you have a Subaru Select Monitor?	Go to step 7.	Go to step 5.

DIAGNOSTIC PROCEDURE WITH TROUBLE CODE

Automatic Transmission (Diagnostics)

No.	Step	Check	Yes	No
5	<p>CHECK OUTPUT SIGNAL EMITTED FROM TCM.</p> <p>1) Connect all connectors.</p> <p>2) Start the engine and warm-up the transmission until ATF temperature is above 80°C (176°F).</p> <p>NOTE: If ambient temperature is below 0°C (32°F), drive the vehicle until the ATF reaches its operating temperature.</p> <p>3) Turn ignition switch to ON (engine OFF).</p> <p>4) Move select lever to "N".</p> <p>5) Measure voltage between TCM connector and chassis ground.</p> <p>Connector & terminal (B54) No. 18 (+) — Chassis ground (-):</p>	Is the voltage between 1.5 and 5.0 V with throttle fully closed?	Go to step 6.	Go to step 9.
6	<p>CHECK OUTPUT SIGNAL EMITTED FROM TCM.</p> <p>Measure voltage between TCM connector and chassis ground.</p> <p>Connector & terminal (B54) No. 18 (+) — Chassis ground (-):</p>	Is the voltage less than 1 V with throttle fully open?	Even if "POWER" indicator lights up, the circuit has returned to a normal condition at this time. A temporary poor contact of the connector or harness may be the cause. Repair harness or connector in TCM and transmission.	Go to step 9.
7	<p>CHECK OUTPUT SIGNAL EMITTED FROM TCM USING SUBARU SELECT MONITOR.</p> <p>1) Connect all connectors.</p> <p>2) Connect Subaru Select Monitor to data link connector.</p> <p>3) Start the engine, and turn Subaru Select Monitor switch to ON.</p> <p>4) Warm-up the transmission until ATF temperature is above 80°C (176°F).</p> <p>NOTE: If ambient temperature is below 0°C (32°F), drive the vehicle until the ATF reaches its operating temperature.</p> <p>5) Stop the engine and turn ignition switch to ON (engine OFF).</p> <p>6) Move select lever to "N".</p> <p>7) Read data of 2-4 brake duty solenoid using Subaru Select Monitor.</p> <ul style="list-style-type: none"> ● 2-4 brake duty solenoid is indicated in "%". <p>8) Throttle is fully closed.</p>	Is the value 100%?	Go to step 8.	Go to step 9.

DIAGNOSTIC PROCEDURE WITH TROUBLE CODE

Automatic Transmission (Diagnostics)

No.	Step	Check	Yes	No
8	CHECK OUTPUT SIGNAL EMITTED FROM TCM USING SUBARU SELECT MONITOR. 1) Turn ignition switch to ON (Engine OFF). 2) Throttle is fully open.	Is the value less than 25%?	Even if "POWER" indicator lights up, the circuit has returned to a normal condition at this time. A temporary poor contact of the connector or harness may be the cause. Repair harness or connector in TCM and transmission.	Go to step 9.
9	CHECK POOR CONTACT.	Is there poor contact in 2-4 brake duty solenoid circuit?	Repair poor contact.	Replace TCM. <Ref. to AT-48, Transmission Control Module (TCM).>
10	CHECK 2-4 BRAKE DUTY SOLENOID (IN TRANSMISSION). 1) Remove transmission connector from bracket. 2) Drain automatic transmission fluid. CAUTION: Do not drain the automatic transmission fluid until it cools down. 3) Remove oil pan, and disconnect connector from 2-4 brake duty solenoid. 4) Measure resistance between 2-4 brake duty solenoid connector and transmission ground. <i>Terminal</i> <i>No. 1 — Transmission ground:</i>	Is the resistance between 2.0 and 4.5 Ω?	Go to step 11.	Replace 2-4 brake duty solenoid. <Ref. to AT-41, Shift Solenoids, Duty Solenoids and ATF Temperature Sensor.>
11	CHECK HARNESS CONNECTOR BETWEEN TRANSMISSION AND 2-4 BRAKE DUTY SOLENOID. Measure resistance of harness between 2-4 brake duty solenoid and transmission connector. <i>Connector & terminal</i> <i>(T4) No. 9 — (AT7) No. 1:</i>	Is the resistance less than 1 Ω?	Go to step 12.	Repair open circuit in harness between 2-4 brake duty solenoid and transmission connector.
12	CHECK HARNESS CONNECTOR BETWEEN TRANSMISSION AND 2-4 BRAKE DUTY SOLENOID. Measure resistance of harness between transmission connector and transmission ground. <i>Connector & terminal</i> <i>(T4) No. 9 — Transmission ground:</i>	Is the resistance more than 1 MΩ?	Even if "POWER" indicator lights up, the circuit has returned to a normal condition at this time. A temporary poor contact of the connector or harness may be the cause. Repair harness or connector in line pressure duty solenoid and transmission.	Repair short circuit in harness between 2-4 brake duty solenoid and transmission connector.

DIAGNOSTIC PROCEDURE WITH TROUBLE CODE

Automatic Transmission (Diagnostics)

MEMO:

DIAGNOSTIC PROCEDURE WITH TROUBLE CODE

Automatic Transmission (Diagnostics)

O: TROUBLE CODE 77 — LOCK-UP DUTY SOLENOID — S004509E16

DIAGNOSIS:

Output signal circuit of lock-up duty solenoid is open or shorted.

TROUBLE SYMPTOM:

No "lock-up" (after engine warm-up).

WIRING DIAGRAM:

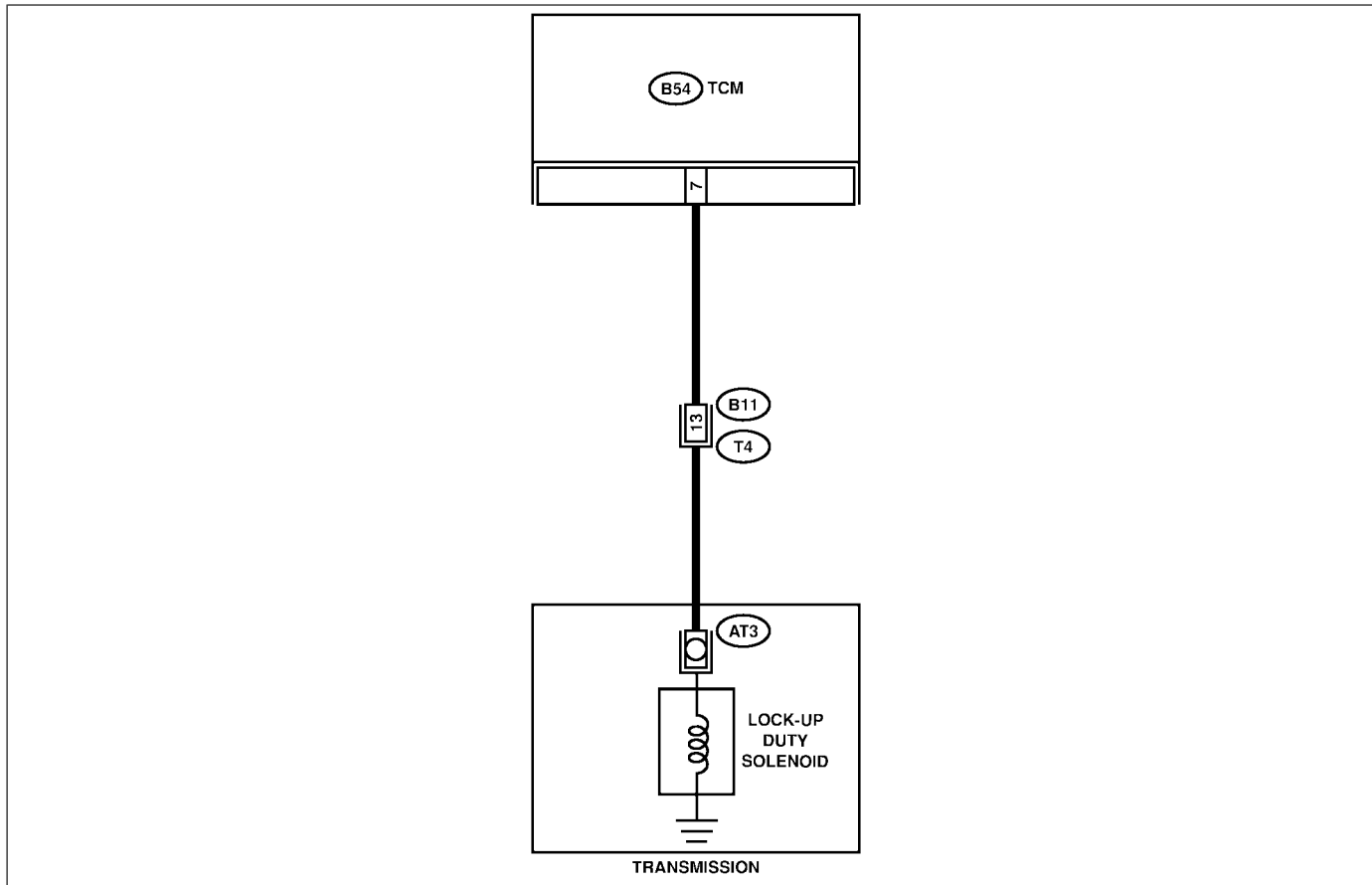

TR0416

No.	Step	Check	Yes	No
1	CHECK TROUBLE CODE.	Do multiple trouble codes appear in the on-board diagnostics test mode?	Go to another trouble code.	Go to step 2.

DIAGNOSTIC PROCEDURE WITH TROUBLE CODE

Automatic Transmission (Diagnostics)

No.	Step	Check	Yes	No
2	<p>CHECK HARNESS CONNECTOR BETWEEN TCM AND TRANSMISSION. 1) Turn ignition switch to OFF. 2) Disconnect connector from TCM and transmission. 3) Measure resistance of harness between TCM and transmission connector. Connector & terminal (B54) No. 7 — (B11) No. 13:</p>	Is the resistance less than 1 Ω?	Go to step 3.	Repair open circuit in harness between TCM and transmission connector.
3	<p>CHECK HARNESS CONNECTOR BETWEEN TCM AND TRANSMISSION. Measure resistance of harness connector between TCM and chassis ground. Connector & terminal (B54) No. 7 — Chassis ground:</p>	Is the resistance more than 1 MΩ?	Go to step 4.	Repair short circuit in harness between TCM and transmission connector.
4	<p>CHECK LOCK-UP DUTY SOLENOID. Measure resistance between transmission connector receptacle's terminals. Connector & terminal (T4) No. 13 — No. 16:</p>	Is the resistance between 10 and 17 Ω?	Go to step 5.	Go to step 11.
5	<p>PREPARE SUBARU SELECT MONITOR.</p>	Do you have a Subaru Select Monitor?	Go to step 8.	Go to step 6.
6	<p>CHECK OUTPUT SIGNAL EMITTED FROM TCM. 1) Connect connectors to TCM and transmission. 2) Lift-up the vehicle and place safety stand. CAUTION: On AWD models, raise all wheels off ground. 3) Start the engine and warm-up the transmission until ATF temperature is above 80°C (176°F). NOTE: If ambient temperature is below 0°C (32°F), drive the vehicle until the ATF reaches its operating temperature. 4) Move selector lever to "D" and slowly increase vehicle speed to 75 km/h (47 MPH). Wheels will lock-up. NOTE: The speed difference between front and rear wheels may light the ABS warning light, but this indicates no malfunction. When AT control diagnosis is finished, perform the ABS memory clearance procedure of on-board diagnostics system. <Ref. to ABS-22, Clear Memory Mode.> 5) Measure voltage between TCM connector and chassis ground. Connector & terminal (B54) No. 7 (+) — Chassis ground (-):</p>	Is the voltage more than 8.5 V?	Go to step 7.	Go to step 10.

DIAGNOSTIC PROCEDURE WITH TROUBLE CODE

Automatic Transmission (Diagnostics)

No.	Step	Check	Yes	No
7	<p>CHECK OUTPUT SIGNAL EMITTED FROM TCM.</p> <p>1) Return the engine to idling speed and move select lever to "N".</p> <p>2) Measure voltage between TCM connector and chassis ground.</p> <p>Connector & terminal (B54) No. 7 (+) — Chassis ground (-):</p>	Is the voltage less than 0.5 V?	Even if "POWER" indicator lights up, the circuit has returned to a normal condition at this time. A temporary poor contact of the connector or harness may be the cause. Repair harness or connector in TCM and transmission.	Go to step 10.
8	<p>CHECK OUTPUT SIGNAL EMITTED FROM TCM USING SUBARU SELECT MONITOR.</p> <p>1) Connect connectors to TCM and transmission.</p> <p>2) Lift-up the vehicle and place safety stand.</p> <p>CAUTION: On AWD models, raise all wheels off ground.</p> <p>3) Connect Subaru Select Monitor to data link connector.</p> <p>4) Start the engine, and turn Subaru Select Monitor switch to ON.</p> <p>5) Start the engine and warm-up the transmission until ATF temperature is above 80°C (176°F).</p> <p>NOTE: If ambient temperature is below 0°C (32°F), drive the vehicle until the ATF reaches its operating temperature.</p> <p>6) Read data of lock-up duty solenoid using Subaru Select Monitor.</p> <ul style="list-style-type: none"> ● Lock-up duty solenoid is indicated in "%". <p>7) Move selector lever to "D" and slowly increase vehicle speed to 75 km/h (47 MPH). Wheels will lock-up.</p> <p>NOTE: The speed difference between front and rear wheels may light the ABS warning light, but this indicates no malfunction. When AT control diagnosis is finished, perform the ABS memory clearance procedure of on-board diagnostics system. <Ref. to ABS-22, Clear Memory Mode.></p>	Is the value 95%?	Go to step 9.	Go to step 10.
9	<p>CHECK OUTPUT SIGNAL EMITTED FROM TCM USING SUBARU SELECT MONITOR.</p> <p>Return the engine to idling speed and move selector lever to "N".</p> <p>NOTE: The speed difference between front and rear wheels may light the ABS warning light, but this indicates no malfunction. When AT control diagnosis is finished, perform the ABS memory clearance procedure of on-board diagnostics system. <Ref. to ABS-22, Clear Memory Mode.></p>	Is the value 5%?	Even if "POWER" indicator lights up, the circuit has returned to a normal condition at this time. A temporary poor contact of the connector or harness may be the cause. Repair harness or connector in TCM and transmission.	Go to step 10.

DIAGNOSTIC PROCEDURE WITH TROUBLE CODE

Automatic Transmission (Diagnostics)

No.	Step	Check	Yes	No
10	CHECK POOR CONTACT.	Is there poor contact in lock-up duty solenoid circuit?	Repair poor contact.	Replace TCM. <Ref. to AT-48, Transmission Control Module (TCM).>
11	CHECK LOCK-UP DUTY SOLENOID (IN TRANSMISSION). 1) Remove transmission connector from bracket. 2) Drain automatic transmission fluid. CAUTION: Do not drain the automatic transmission fluid until it cools down. 3) Remove oil pan, and disconnect connector from lock-up duty solenoid. 4) Measure resistance between lock-up duty solenoid connector and transmission ground. <i>Terminal</i> <i>No. 1 — Transmission ground:</i>	Is the resistance between 10 and 17 Ω ?	Go to step 12.	Replace lock-up duty solenoid. <Ref. to AT-41, Shift Solenoids, Duty Solenoids and ATF Temperature Sensor.>
12	CHECK HARNESS CONNECTOR BETWEEN LOCK-UP DUTY SOLENOID AND TRANSMISSION. Measure resistance of harness between lock-up duty solenoid and transmission connector. <i>Connector & terminal</i> <i>(T4) No. 13 — (AT3) No. 1:</i>	Is the resistance less than 1 Ω ?	Go to step 13.	Repair open circuit in harness between TCM and transmission connector.
13	CHECK HARNESS CONNECTOR BETWEEN LOCK-UP DUTY SOLENOID AND TRANSMISSION. Measure resistance of harness between transmission connector and transmission ground. <i>Connector & terminal</i> <i>(T4) No. 13 — Transmission ground:</i>	Is the resistance more than 1 M Ω ?	Even if "POWER" indicator lights up, the circuit has returned to a normal condition at this time. A temporary poor contact of the connector or harness may be the cause. Repair harness or connector in lock-up duty solenoid and transmission.	Repair short circuit in harness between lock-up duty solenoid and transmission connector.

DIAGNOSTIC PROCEDURE WITH TROUBLE CODE

Automatic Transmission (Diagnostics)

P: TROUBLE CODE 79 — TRANSFER DUTY SOLENOID — S004509E17

DIAGNOSIS:

Output signal circuit of transfer duty solenoid is open or shorted.

TROUBLE SYMPTOM:

Excessive “braking” in tight corners.

WIRING DIAGRAM:

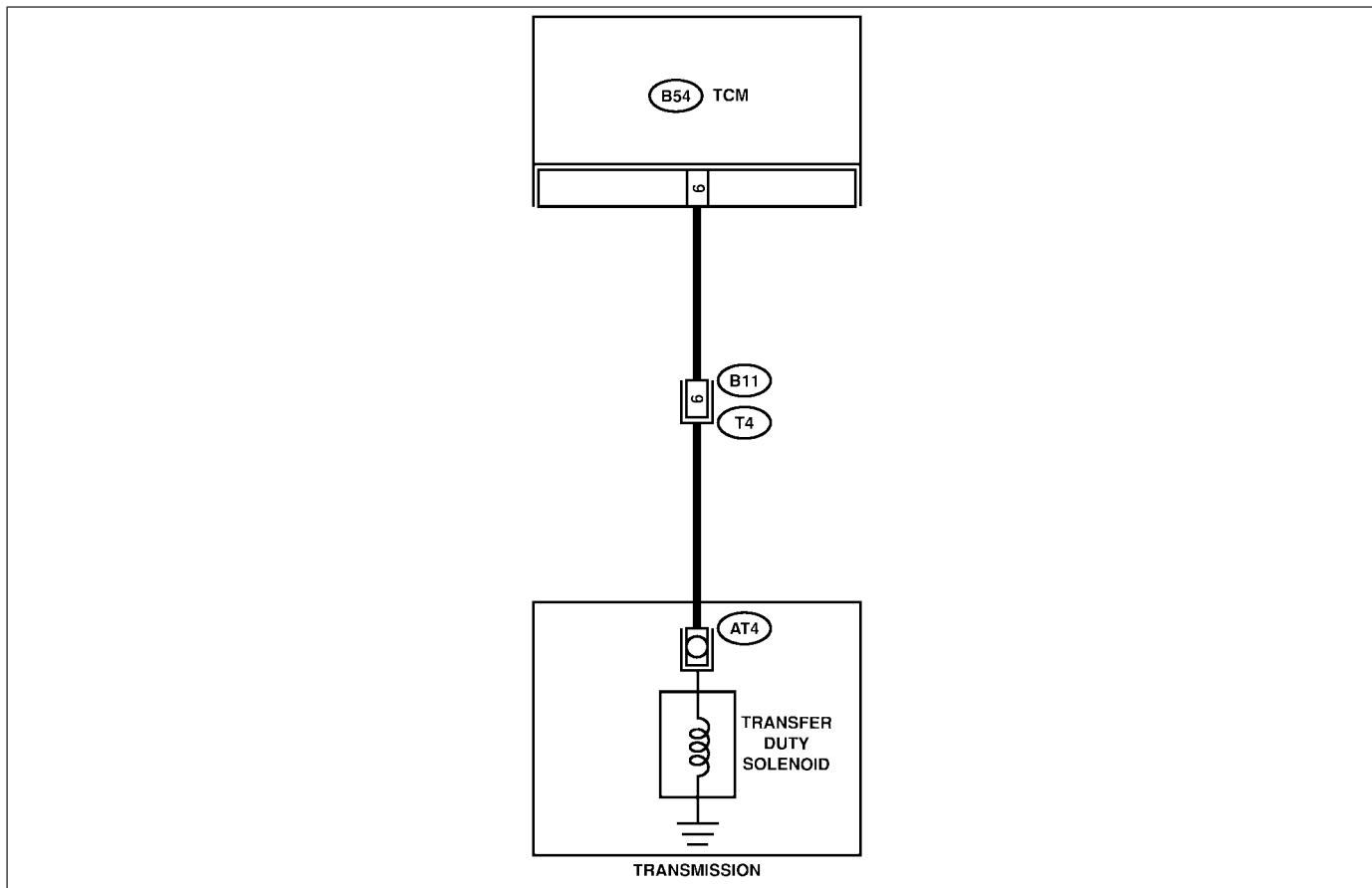

TR0417

No.	Step	Check	Yes	No
1	<p>CHECK HARNESS CONNECTOR BETWEEN TCM AND TRANSMISSION.</p> <p>1) Turn ignition switch to OFF.</p> <p>2) Disconnect connector from TCM and transmission.</p> <p>3) Measure resistance of harness between TCM and transmission connector.</p> <p>Connector & terminal (B54) No. 6 — (B11) No. 6:</p>	Is the resistance less than 1 Ω?	Go to step 2.	Repair open circuit in harness between TCM and transmission connector.

DIAGNOSTIC PROCEDURE WITH TROUBLE CODE

Automatic Transmission (Diagnostics)

No.	Step	Check	Yes	No
2	CHECK HARNESS CONNECTOR BETWEEN TCM AND TRANSMISSION. Measure resistance harness connector between TCM and chassis ground. <i>Connector & terminal</i> <i>(B54) No. 6 — Chassis ground:</i>	Is the resistance more than 1 M Ω ?	Go to step 3.	Repair short circuit in harness between TCM and transmission connector.
3	CHECK TRANSFER DUTY SOLENOID. Measure resistance between transmission connector and transmission terminals. <i>Connector & terminal</i> <i>(T4) No. 6 — No. 16:</i>	Is the resistance between 10 and 17 Ω ?	Go to step 4.	Go to step 10.
4	PREPARE SUBARU SELECT MONITOR.	Do you have a Subaru Select Monitor?	Go to step 7.	Go to step 5.
5	CHECK OUTPUT SIGNAL EMITTED FROM TCM. 1) Connect connectors to TCM and transmission. 2) Turn ignition switch to ON (engine OFF). 3) Throttle is fully closed. 4) Measure voltage between TCM connector and chassis ground. <i>Connector & terminal</i> <i>(B54) No. 6 (+) — Chassis ground (-):</i>	Is the voltage less than 1 V in "P" range?	Go to step 6.	Go to step 9.
6	CHECK OUTPUT SIGNAL EMITTED FROM TCM. Measure voltage between TCM connector and chassis ground. <i>Connector & terminal</i> <i>(B54) No. 6 (+) — Chassis ground (-):</i>	Is the voltage between 5 and 7 V in "D" range?	Even if "POWER" indicator lights up, the circuit has returned to a normal condition at this time. A temporary poor contact of the connector or harness may be the cause. Repair harness or connector in the TCM and transmission.	Go to step 9.
7	CHECK OUTPUT SIGNAL EMITTED FROM TCM USING SUBARU SELECT MONITOR. 1) Connect connectors to TCM and transmission. 2) Connect Subaru Select Monitor to data link connector. 3) Turn ignition switch to ON (engine OFF) and turn Subaru Select Monitor switch to ON. 4) Move select lever to "D" with throttle fully open (vehicle speed 0 km/h or 0 MPH). 5) Read data of transfer duty solenoid using Subaru Select Monitor. ● Transfer duty solenoid is indicated in "%".	Is the value between 5 and 10%?	Go to step 8.	Go to step 9.

DIAGNOSTIC PROCEDURE WITH TROUBLE CODE

Automatic Transmission (Diagnostics)

No.	Step	Check	Yes	No
8	CHECK OUTPUT SIGNAL EMITTED FROM TCM USING SUBARU SELECT MONITOR. 1) Move select lever to "N" with throttle fully closed (vehicle speed 0 km/h or 0 MPH). 2) Rear data of transfer duty solenoid using Subaru Select Monitor. ● Transfer duty solenoid is indicated in "%".	Is the value between approx. 60% and approx. 70%?	Even if "POWER" indicator lights up, the circuit has returned to a normal condition at this time. A temporary poor contact of the connector or harness may be the cause. Repair harness or connector in the TCM and transmission.	Go to step 9.
9	CHECK POOR CONTACT.	Is there poor contact in transfer duty solenoid circuit?	Repair poor contact.	Replace TCM. <Ref. to AT-48, Transmission Control Module (TCM).>
10	CHECK TRANSFER DUTY SOLENOID (IN TRANSMISSION). 1) Lift-up the vehicle and place safety stand. CAUTION: On AWD models, raise all wheels off ground. 2) Drain automatic transmission fluid. CAUTION: Do not drain the automatic transmission fluid until it cools down. 3) Remove extension case, and disconnect connector from transfer duty solenoid. 4) Measure resistance between transfer duty solenoid connector and transmission ground. Connector & terminal (AT4) No. 1 — Transmission ground:	Is the resistance between 10 and 17 Ω?	Go to step 11.	Replace transfer duty solenoid.
11	CHECK HARNESS CONNECTOR BETWEEN TRANSFER DUTY SOLENOID AND TRANSMISSION. Measure resistance of harness between transfer duty solenoid and transmission connector. Connector & terminal (T4) No. 6 — (AT4) No. 1:	Is the resistance less than 1 Ω?	Go to step 12.	Repair open circuit in harness between transfer duty solenoid and transmission connector.
12	CHECK HARNESS CONNECTOR BETWEEN TRANSFER DUTY SOLENOID AND TRANSMISSION. Measure resistance of harness between transmission connector and transmission ground. Connector & terminal (T4) No. 6 — Transmission ground:	Is the resistance more than 1 MΩ?	Even if "POWER" indicator lights up, the circuit has returned to a normal condition at this time. A temporary poor contact of the connector or harness may be the cause. Repair harness or contact in the transfer duty solenoid and transmission.	Repair short circuit in harness between transfer duty solenoid and transmission connector.

DIAGNOSTIC PROCEDURE WITH TROUBLE CODE

Automatic Transmission (Diagnostics)

MEMO:

DIAGNOSTIC PROCEDURE WITH TROUBLE CODE

Automatic Transmission (Diagnostics)

Q: TROUBLE CODE 93 — REAR VEHICLE SPEED SENSOR — S004509F61

DIAGNOSIS:

Input signal circuit of TCM is open or shorted.

TROUBLE SYMPTOM:

No lock-up or excessive tight corner "braking".

WIRING DIAGRAM:

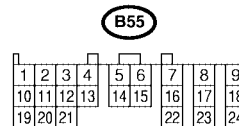
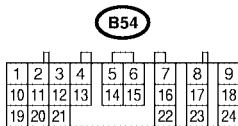
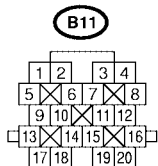
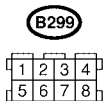
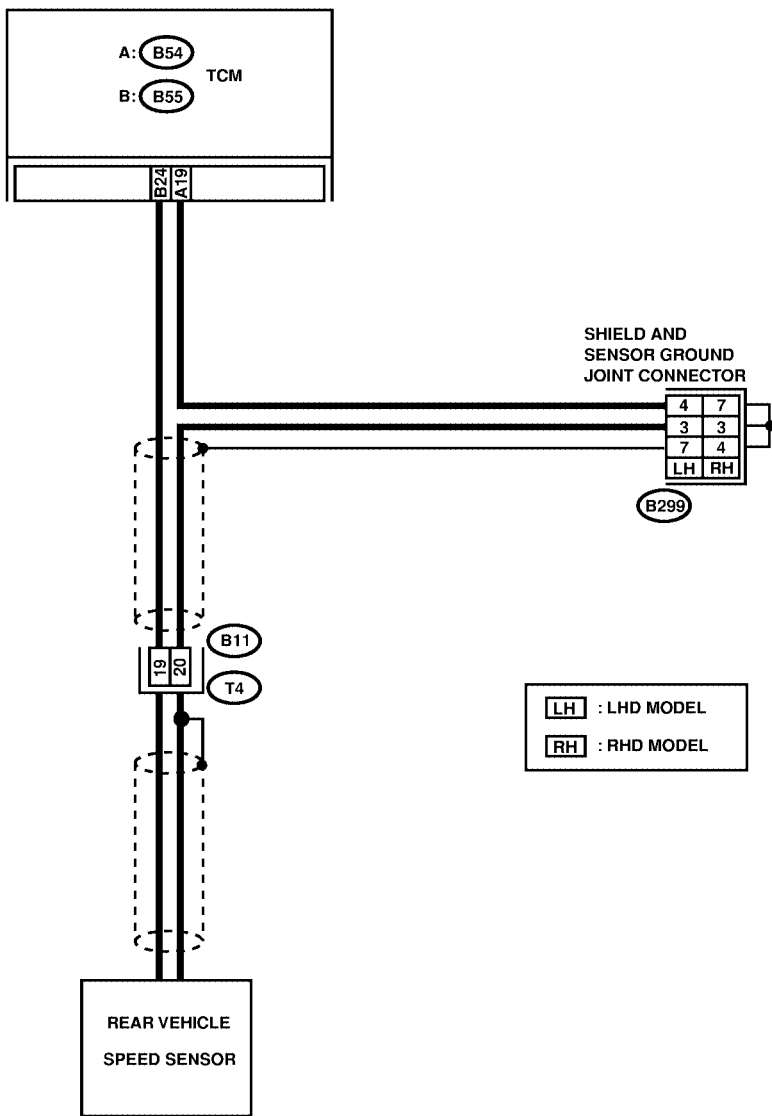

DIAGNOSTIC PROCEDURE WITH TROUBLE CODE

Automatic Transmission (Diagnostics)

No.	Step	Check	Yes	No
1	CHECK HARNESS CONNECTOR BETWEEN TCM AND TRANSMISSION. 1) Turn ignition switch to OFF. 2) Disconnect connector from TCM and transmission. 3) Measure resistance of harness between TCM and transmission connector. Connector & terminal (B55) No. 24 — (B11) No. 19:	Is the resistance less than 1 Ω?	Go to step 2.	Repair open circuit in harness between TCM and transmission connector.
2	CHECK HARNESS CONNECTOR BETWEEN TCM AND TRANSMISSION. Measure resistance of harness between TCM and transmission connector. Connector & terminal (B54) No. 19 — (B11) No. 20:	Is the resistance less than 1 Ω?	Go to step 3.	Repair open circuit in harness between TCM and transmission, and poor contact in coupling connector.
3	CHECK HARNESS CONNECTOR BETWEEN TCM AND TRANSMISSION. Measure resistance of harness between TCM and chassis ground. Connector & terminal (B55) No. 24 — Chassis ground:	Is the resistance more than 1 MΩ?	Go to step 4.	Repair short circuit in harness between TCM and transmission connector.
4	CHECK HARNESS CONNECTOR BETWEEN TCM AND TRANSMISSION. Measure resistance of harness between TCM and chassis ground. Connector & terminal (B54) No. 19 — Chassis ground:	Is the resistance more than 1 MΩ?	Go to step 5.	Repair short circuit in harness between TCM and transmission connector.
5	CHECK REAR VEHICLE SPEED SENSOR. Measure resistance between transmission connector receptacle's terminals. Connector & terminal (T4) No. 19 — No. 20:	Is the resistance between 450 and 650 Ω?	Go to step 6.	Replace rear vehicle speed sensor. <Ref. to AT-36, Rear Vehicle Speed Sensor.>
6	PREPARE OSCILLOSCOPE.	Do you have oscilloscope?	Go to step 10.	Go to step 7.
7	PREPARE SUBARU SELECT MONITOR.	Do you have a Subaru Select Monitor?	Go to step 9.	Go to step 8.
8	CHECK INPUT SIGNAL FOR TCM. 1) Connect connectors to TCM and transmission. 2) Lift-up or raise the vehicle and place safety stands. CAUTION: On AWD models, raise all wheels off floor. 3) Start the engine and set vehicle in 20 km/h (12 MPH) condition. NOTE: The speed difference between front and rear wheels may light the ABS warning light, but this indicates no malfunction. When AT control diagnosis is finished, perform the ABS memory clearance procedure of on-board diagnostics system. <Ref. to ABS-22, Clear Memory Mode.> 4) Measure voltage between TCM connector terminals. Connector & terminal (B55) No. 24 (+) — (B54) No. 19 (-):	Is the voltage more than AC 1 V?	Even if "POWER" indicator lights up, the circuit has returned to a normal condition at this time. A temporary poor contact of the connector or harness may be the cause. Repair harness or connector in the TCM and transmission.	Go to step 11.

DIAGNOSTIC PROCEDURE WITH TROUBLE CODE

Automatic Transmission (Diagnostics)

No.	Step	Check	Yes	No
9	<p>CHECK INPUT SIGNAL FOR TCM USING SUBARU SELECT MONITOR.</p> <p>1) Connect connectors to TCM and transmission.</p> <p>2) Connect Subaru Select Monitor to data link connector.</p> <p>3) Lift-up or raise the vehicle and place safety stands.</p> <p>CAUTION: On AWD models, raise all wheels off floor.</p> <p>4) Turn ignition switch to ON and turn Subaru Select Monitor switch to ON.</p> <p>5) Start the engine.</p> <p>6) Read data of vehicle speed using Subaru Select Monitor.</p> <ul style="list-style-type: none"> ● Compare speedometer with Subaru Select Monitor indications. ● Vehicle speed is indicated in "km/h" or "MPH". <p>7) Slowly increase vehicle speed to 60 km/h or 37 MPH.</p> <p>NOTE: The speed difference between front and rear wheels may light the ABS warning light, but this indicates no malfunction. When AT control diagnosis is finished, perform the ABS memory clearance procedure of on-board diagnostics system. <Ref. to ABS-22, Clear Memory Mode.></p>	Does the speedometer indication increase as the Subaru Select Monitor data increases?	Even if "POWER" indicator lights up, the circuit has returned to a normal condition at this time. A temporary poor contact of the connector or harness may be the cause. Repair harness or connector in the TCM and transmission.	Go to step 11.
10	<p>CHECK INPUT SIGNAL FOR TCM USING OSCILLOSCOPE.</p> <p>1) Connect connectors to TCM and transmission.</p> <p>2) Lift-up or raise the vehicle and place safety stands.</p> <p>CAUTION: On AWD models, raise all wheels off floor.</p> <p>3) Set oscilloscope to TCM connector terminals.</p> <p>Positive probe; (B55) No. 24 Earth lead; (B54) No. 19</p> <p>4) Start the engine and set vehicle in 20 km/h (12 MPH) condition.</p> <p>NOTE: The speed difference between front and rear wheels may light the ABS warning light, but this indicates no malfunction. When AT control diagnosis is finished, perform the ABS memory clearance procedure of on-board diagnostics system. <Ref. to ABS-22, Clear Memory Mode.></p> <p>5) Measure signal voltage indicated on oscilloscope.</p>	Is the signal voltage more than AC 1 V?	Even if "POWER" indicator lights up, the circuit has returned to a normal condition at this time. A temporary poor contact of the connector or harness may be the cause. Repair harness or connector in the TCM and transmission.	Go to step 11.
11	<p>CHECK POOR CONTACT.</p>	Is there poor contact in rear vehicle speed sensor circuit?	Repair poor contact.	Replace TCM. <Ref. to AT-48, Transmission Control Module (TCM).>

DIAGNOSTIC PROCEDURE FOR NO-TROUBLE CODE

Automatic Transmission (Diagnostics)

15. Diagnostic Procedure for No-trouble Code

S004618

A: CHECK GEAR POSITION. S004618F15

No.	Step	Check	Yes	No
1	<p>CHECK GEAR POSITION.</p> <p>1) Lift-up the vehicle and place safety stand.</p> <p>CAUTION: On AWD models, raise all wheels off ground.</p> <p>2) Start the engine.</p> <p>3) Move select lever to "D", and drive vehicle.</p> <p>4) Read data of gear position using Subaru Select Monitor.</p> <ul style="list-style-type: none">● Gear position is indicated. <p>NOTE: The speed difference between front and rear wheels may light the ABS warning light, but this indicates no malfunction. When AT control diagnosis is finished, perform the ABS memory clearance procedure of on-board diagnostics system. <Ref. to ABS-22, Clear Memory Mode.></p>	<p>Does the transmission gear correspond to the gear which is shown on display?</p>	<p>Go to step CHECK FWD SWITCH. <Ref. to AT-108, CHECK FWD SWITCH., Diagnostic Procedure for No-trouble Code.></p>	<p>Check shift solenoid 1 and shift solenoid 2 signal circuit. <Ref. to AT-72, TROUBLE CODE 71 - SHIFT SOLENOID 1 -, Diagnostic Procedure with Trouble Code.> and <Ref. to AT-76, TROUBLE CODE 72 - SHIFT SOLENOID 2 -, Diagnostic Procedure with Trouble Code.></p>

DIAGNOSTIC PROCEDURE FOR NO-TROUBLE CODE

Automatic Transmission (Diagnostics)

B: CHECK FWD SWITCH. S004618F16

DIAGNOSIS:

- LED does not come on even if FWD switch is ON.
- FWD switch circuit is open or short.

DIAGNOSTIC PROCEDURE FOR NO-TROUBLE CODE

Automatic Transmission (Diagnostics)

WIRING DIAGRAM:

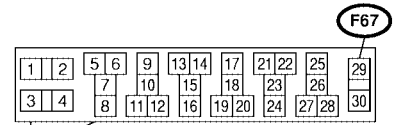
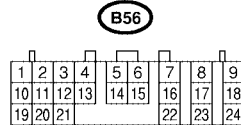
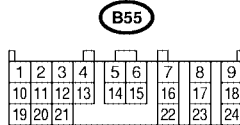
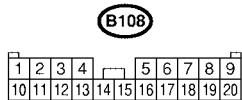
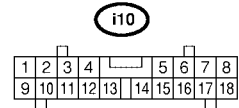
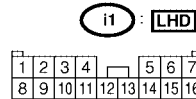
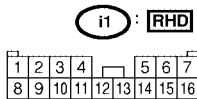
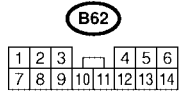
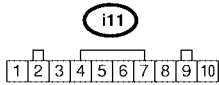
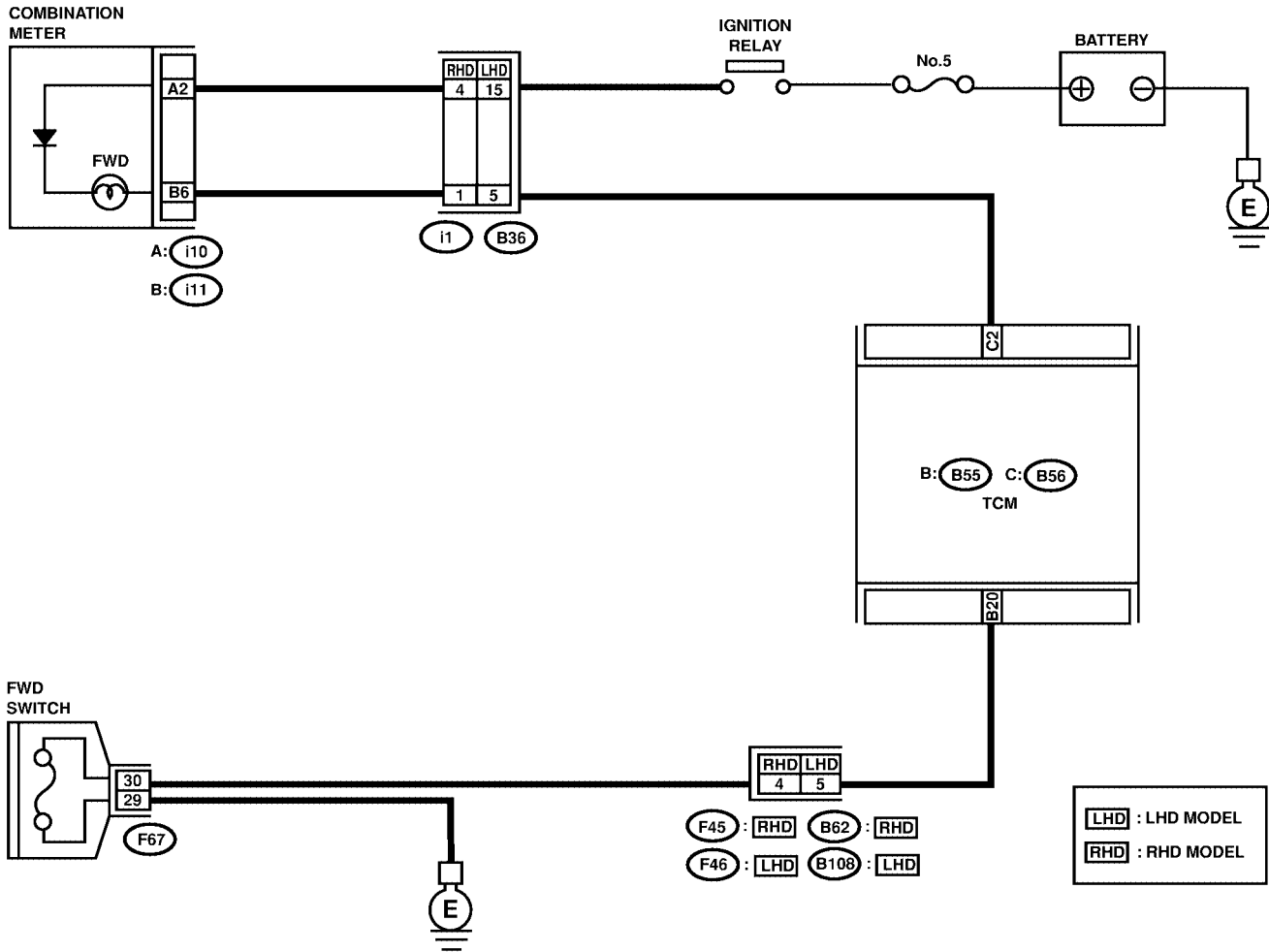

S3M0634

DIAGNOSTIC PROCEDURE FOR NO-TROUBLE CODE

Automatic Transmission (Diagnostics)

No.	Step	Check	Yes	No
1	CHECK FWD SWITCH.	When fuse is inserted to FWD switch, does LED light up?	Go to step CHECK BRAKE SWITCH.<Ref. to AT-111, CHECK BRAKE SWITCH., Diagnostic Procedure for No-trouble Code.>	Go to step 2.
2	CHECK FWD INDICATOR LIGHT. 1) Turn ignition switch to OFF. 2) Remove combination meter. 3) Remove FWD indicator light bulb from combination meter.	Is FWD indicator light bulb OK?	Go to step 3.	Replace FWD indicator light bulb. <Ref. to IDI-15, Combination Meter Assembly.>
3	CHECK HARNESS CONNECTOR BETWEEN TCM AND FWD SWITCH. 1) Turn ignition switch to OFF. 2) Disconnect connector from TCM and FWD switch. 3) Measure resistance of harness between TCM and FWD switch connector. Connector & terminal (B55) No. 20 — (F67) No. 30:	Is the resistance less than 1 Ω?	Go to step 4.	Repair open circuit in harness between TCM and FWD switch connector.
4	CHECK HARNESS CONNECTOR BETWEEN FWD SWITCH AND CHASSIS GROUND. Measure resistance of harness between FWD switch and chassis ground. Connector & terminal (F67) No. 29 — Chassis ground:	Is the resistance less than 1 Ω?	Go to step 5.	Repair open circuit in harness between FWD switch connector and chassis ground.
5	CHECK HARNESS CONNECTOR BETWEEN TCM AND FWD SWITCH. Measure resistance of harness connector between TCM and body to make sure that circuit does not short. Connector & terminal (B55) No. 20 — Chassis ground:	Is the resistance more than 1 MΩ?	Go to step 6.	Repair short circuit in harness between TCM and FWD switch connector.
6	CHECK INPUT SIGNAL FOR TCM. 1) Turn ignition switch to OFF. 2) Connect connector to TCM and FWD switch. 3) Turn ignition switch to ON. 4) Measure signal voltage for TCM while installing the fuse to FWD switch connector. Connector & terminal (B55) No. 20 (+) — Chassis ground (-):	Is the voltage less than 1 V in FWD switch while installing?	Go to step 7.	Go to step 11.
7	CHECK INPUT SIGNAL FOR TCM. Measure signal voltage for TCM while removing the fuse from FWD switch connector. Connector & terminal (B55) No. 20 (+) — Chassis ground (-):	Is the voltage more than 6 V in FWD switch while removing?	Go to step 8.	Replace TCM. <Ref. to AT-48, Transmission Control Module (TCM).>
8	CHECK HARNESS CONNECTOR BETWEEN TCM AND COMBINATION METER. 1) Turn ignition switch to OFF. 2) Disconnect connector from TCM and combination meter. 3) Measure resistance of harness between TCM and diagnosis connector. Connector & terminal (B56) No. 2 — (i11) No. 6:	Is the resistance less than 1 Ω?	Go to step 9.	Repair open circuit in harness between TCM and combination meter and poor contact in coupling connector.

DIAGNOSTIC PROCEDURE FOR NO-TROUBLE CODE

Automatic Transmission (Diagnostics)

No.	Step	Check	Yes	No
9	CHECK HARNESS CONNECTOR BETWEEN TCM AND COMBINATION METER. Measure resistance of harness connector between TCM and chassis ground to make sure that circuit does not short. <i>Connector & terminal (B56) No. 2 — Chassis ground:</i>	Is the resistance more than 1 M Ω ?	Go to step 10.	Repair short circuit in harness between TCM and combination meter connector.
10	CHECK OUTPUT SIGNAL EMITTED FROM TCM. 1) Turn ignition switch to OFF. 2) Connect connector to TCM and combination meter. 3) Turn ignition switch to ON. 4) Measure signal voltage for TCM while installing and removing the fuse to FWD switch connector. <i>Connector & terminal (B56) No. 2 — Chassis ground:</i>	Is the voltage less than 1 V in FWD switch while installing?	Go to step 11.	Go to step 12.
11	CHECK OUTPUT SIGNAL EMITTED FROM TCM. Measure signal voltage for TCM while removing the fuse from FWD switch connector. <i>Connector & terminal (B56) No. 2 — Chassis ground:</i>	Is the voltage more than 9 V in FWD switch while removing?	Go to step 12.	Replace TCM. <Ref. to AT-48, Transmission Control Module (TCM).>
12	CHECK POOR CONTACT.	Is there poor contact in FWD switch circuit?	Repair poor contact.	Replace TCM. <Ref. to AT-48, Transmission Control Module (TCM).>

C: CHECK BRAKE SWITCH. S004618F17

No.	Step	Check	Yes	No
1	CHECK BRAKE SWITCH.	When the brake pedal is depressed, does LED light up?	Go to step CHECK ABS SWITCH. <Ref. to AT-112, CHECK ABS SWITCH, Diagnostic Procedure for No-trouble Code.>	Check brake switch circuit. <Ref. WI-58, A/T Control System.>

DIAGNOSTIC PROCEDURE FOR NO-TROUBLE CODE

Automatic Transmission (Diagnostics)

D: CHECK ABS SWITCH. S004618F18

No.	Step	Check	Yes	No
1	CHECK ABS SWITCH.	Does the LED of ABS switch light up?	Check ABS switch circuit. <Ref. to ABS-134, TROUBLE CODE 44 - ABS-AT CONTROL (NON CONTROLLED) -, Diagnostics Chart with Subaru Select Monitor.> and <Ref. to ABS-136, TROUBLE CODE 44 - ABS-AT CONTROL (CONTROLLED) -, Diagnostics Chart with Subaru Select Monitor.>	Go to step CHECK CRUISE CONTROL SWITCH. <Ref. to AT-112, CHECK CRUISE CONTROL SWITCH., Diagnostic Procedure for No-trouble Code.>

E: CHECK CRUISE CONTROL SWITCH. S004618F19

No.	Step	Check	Yes	No
1	CHECK CRUISE CONTROL SWITCH.	When cruise control is set, does LED light up?	Go to step CHECK KICK-DOWN SWITCH. <Ref. to AT-114, CHECK KICK-DOWN SWITCH., Diagnostic Procedure for No-trouble Code.>	Check cruise control. <Ref. to CC-37, Diagnostics Chart with Trouble Code (Turbo Model).>, <Ref. to CC-57, Diagnostics Chart with Trouble Code (Non-Turbo Model).>

DIAGNOSTIC PROCEDURE FOR NO-TROUBLE CODE

Automatic Transmission (Diagnostics)

MEMO:

DIAGNOSTIC PROCEDURE FOR NO-TROUBLE CODE

Automatic Transmission (Diagnostics)

F: CHECK KICK-DOWN SWITCH. S004618G76

DIAGNOSIS:

- The kick-down switch is not ON when the throttle is fully open but is OFF when the throttle is partially open or fully closed.
- Kick-down switch circuit is open or short.

TROUBLE SYMPTOM:

No kick-down occurs (when the throttle is fully open).

WIRING DIAGRAM:

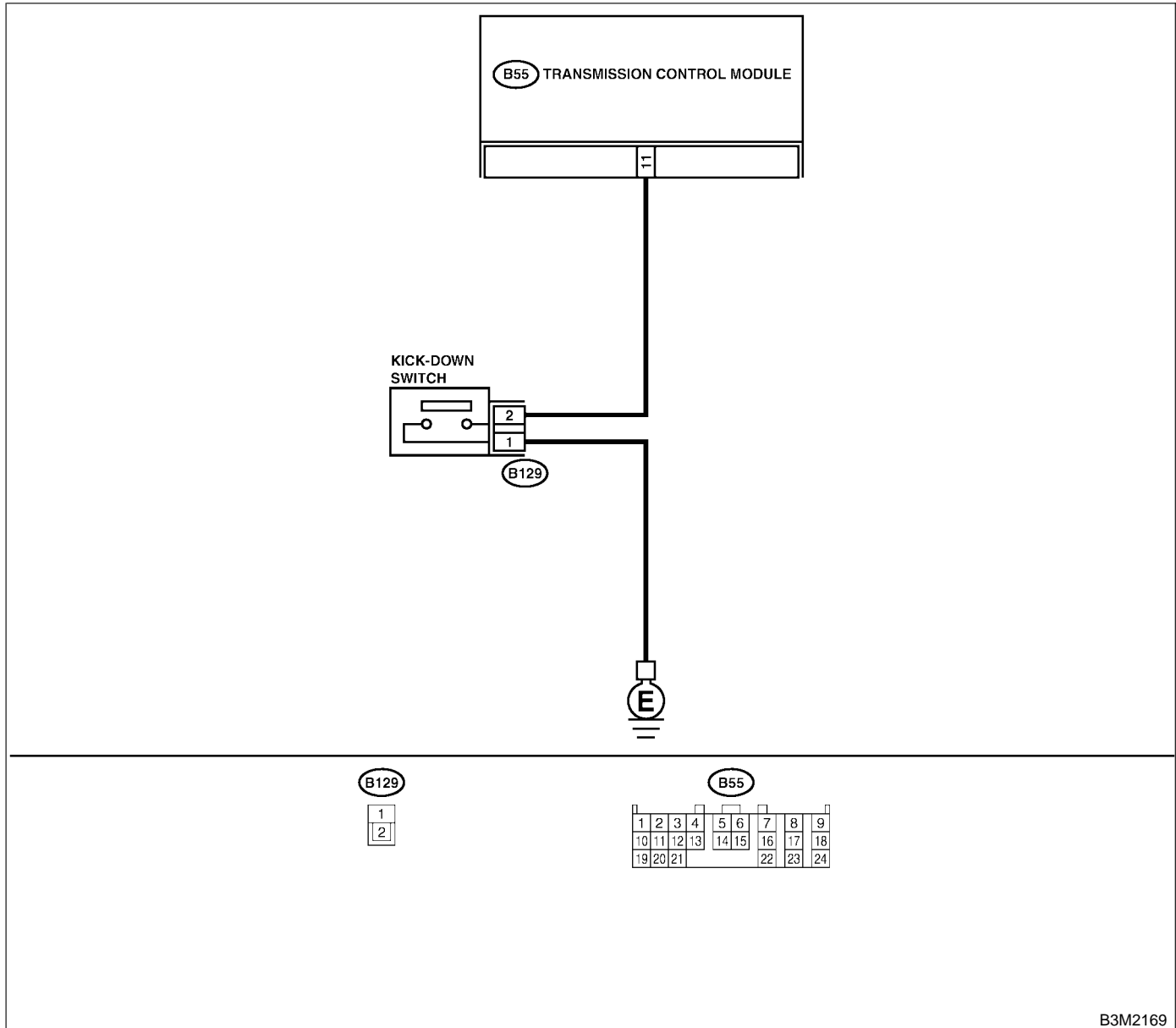

B3M2169

DIAGNOSTIC PROCEDURE FOR NO-TROUBLE CODE

Automatic Transmission (Diagnostics)

No.	Step	Check	Yes	No
1	CHECK KICK-DOWN SWITCH OPERATION.	When the accelerator pedal is depressed, does "ON" displayed?	Go to step CHECK POWER MODE SWITCH. <Ref. to AT-118, CHECK POWER MODE SWITCH, Diagnostic Procedure for No-trouble Code.>	Go to step 2.
2	CHECK KICK-DOWN SWITCH GROUND LINE. 1) Disconnect connector from kick-down switch. 2) Measure resistance of harness connector between kick-down switch and chassis ground. Connector & terminal (B129) No. 1 — Chassis ground:	Is the resistance less than 1 Ω?	Go to step 3.	Repair open circuit in harness between kick-down switch and chassis ground.
3	CHECK KICK-DOWN SWITCH. Measure resistance for kick-down switch when depressing the accelerator pedal. Terminals No. 1 — No. 2:	Is the resistance less than 1 Ω?	Go to step 4.	Replace kick-down switch. <Ref. to SP-5, Accelerator Pedal.>
4	CHECK KICK-DOWN SWITCH. Measure resistance for kick-down switch when pressing the accelerator pedal. Terminals No. 1 — No. 2:	Is the resistance more than 1 MΩ?	Go to step 5.	Replace kick-down switch.
5	CHECK HARNESS CONNECTOR BETWEEN TCM AND KICK-DOWN SWITCH. 1) Turn ignition switch OFF. 2) Disconnect connectors from kick-down switch. 3) Measure resistance of harness connector between TCM and kick-down switch. Connector & terminal (B55) No. 11 — (B129) No. 2:	Is the resistance less than 1 Ω?	Go to step 6.	Repair open circuit in harness between TCM and kick-down switch.
6	CHECK HARNESS CONNECTOR BETWEEN TCM AND KICK-DOWN SWITCH. Measure resistance of harness connector between TCM and chassis ground. Connector & terminal (B55) No. 11 — Chassis ground:	Is the resistance more than 1 MΩ?	Go to step 7.	Repair short circuit in harness between TCM and chassis ground.
7	CHECK INPUT SIGNAL FOR TCM. 1) Turn ignition switch to OFF. 2) Connect connector to kick-down switch. 3) Turn ignition switch ON (with engine OFF). 4) Measure signal voltage for TCM when depressing the accelerator pedal. Connector & terminal (B55) No. 11 (+) — Chassis ground (-):	Is the voltage less than 1 V?	Go to step 8.	Go to step 9.
8	CHECK INPUT SIGNAL FOR TCM. Measure signal voltage for TCM when pressing the accelerator pedal. Connector & terminal (B55) No. 11 (+) — Chassis ground (-):	Is the voltage more than 6.5 V?	A temporary poor contact of the connector and harness may be the cause. Repair harness and connector in the TCM.	Go to step 9.

DIAGNOSTIC PROCEDURE FOR NO-TROUBLE CODE

Automatic Transmission (Diagnostics)

No.	Step	Check	Yes	No
9	CHECK POOR CONTACT.	Is there poor contact?	Repair poor contact.	Replace TCM. <Ref. to AT-48, Transmission Control Module (TCM).>

DIAGNOSTIC PROCEDURE FOR NO-TROUBLE CODE

Automatic Transmission (Diagnostics)

MEMO:

DIAGNOSTIC PROCEDURE FOR NO-TROUBLE CODE

Automatic Transmission (Diagnostics)

G: CHECK POWER MODE SWITCH. S004618G77

DIAGNOSIS:

- LED does not come on when power switch is ON.
- Power switch circuit is open or shorted.

TROUBLE SYMPTOM:

No power mode occurs.

WIRING DIAGRAM:

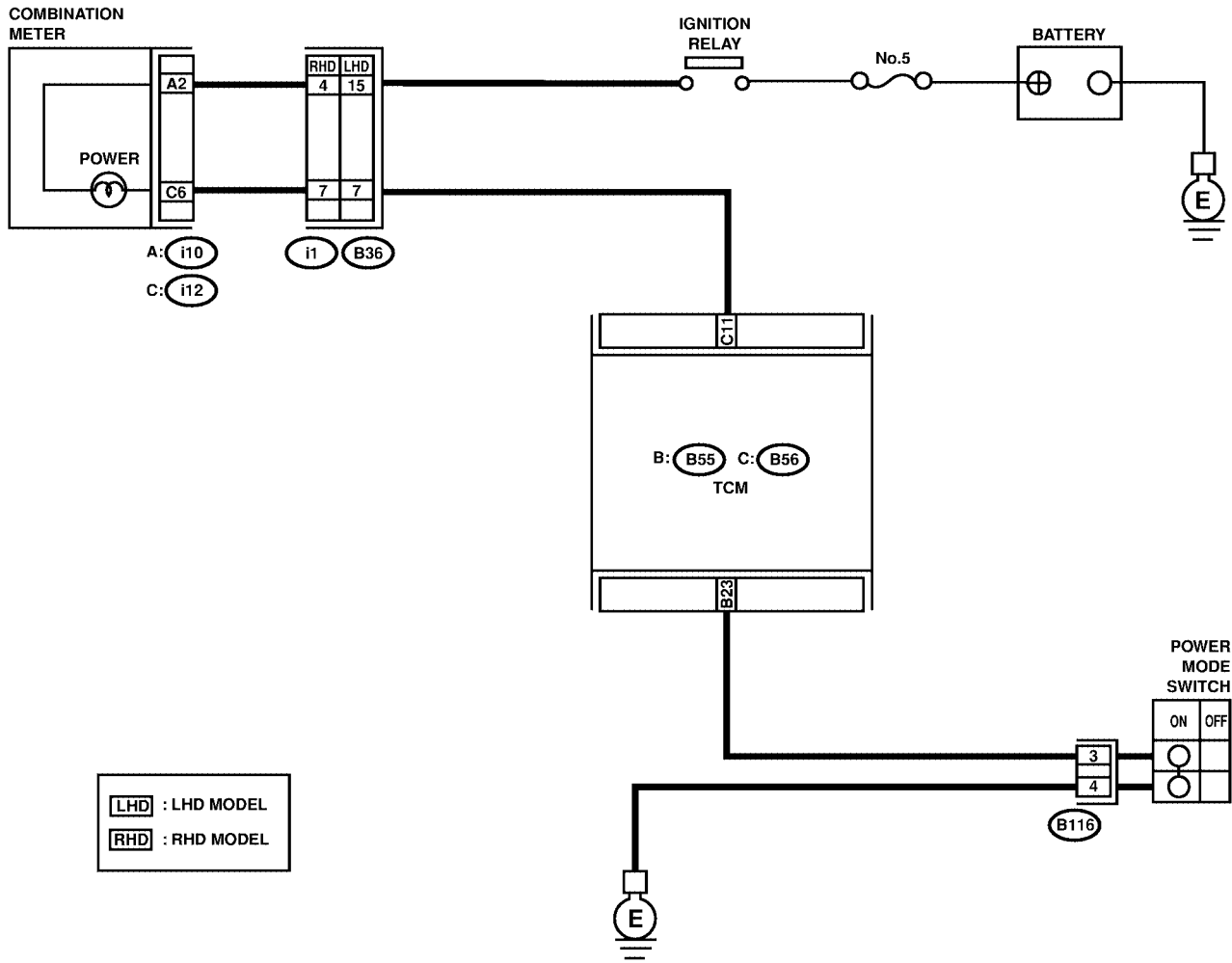

LHD : LHD MODEL
RHD : RHD MODEL

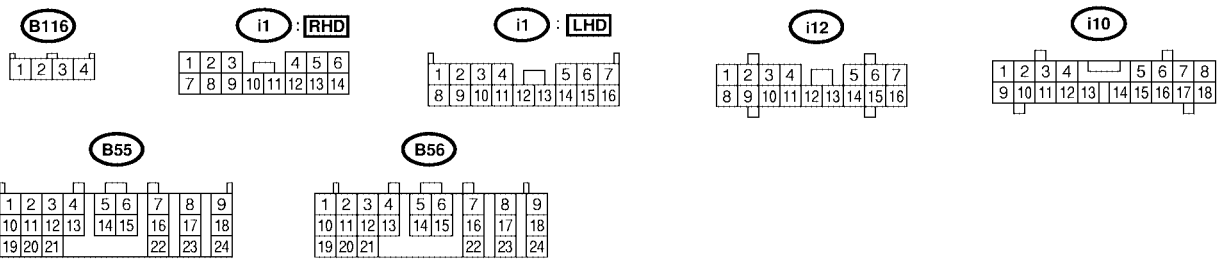

DIAGNOSTIC PROCEDURE FOR NO-TROUBLE CODE

Automatic Transmission (Diagnostics)

No.	Step	Check	Yes	No
1	CHECK POWER SWITCH OPERATION.	When power switch is turned OFF, does LED light up?	Go to step 5.	Go to step 2.
2	CHECK POWER SWITCH OPERATION.	When power switch is turned ON, does LED light up?	Go to step CHECK INHIBITOR SWITCH. <Ref. to AT-122, CHECK INHIBITOR SWITCH., Diagnostic Procedure for No-trouble Code.>	Go to step 3.
3	CHECK POWER INDICATOR LIGHT. 1) Turn ignition switch to OFF. 2) Remove combination meter. 3) Remove POWER indicator light bulb from combination meter.	Is POWER indicator light bulb OK?	Go to step 4.	Replace POWER indicator light bulb. <Ref. to IDI-15, Combination Meter Assembly.>
4	CHECK POWER SWITCH GROUND LINE. 1) Turn ignition switch to OFF. 2) Disconnect connector from power switch. 3) Measure resistance of harness connector between power switch and chassis ground. Connector & terminal (B116) No. 4 — Chassis ground:	Is the resistance less than 1 Ω ?	Go to step 5.	Repair open circuit in harness between power switch and chassis ground.
5	CHECK POWER SWITCH. 1) Power switch turned ON. 2) Measure resistance between terminals of power switch. Terminals No. 3 — No. 4:	Is the resistance less than 1 Ω ?	Go to step 6.	Repair power switch.
6	CHECK POWER SWITCH. 1) Power switch turned OFF. 2) Measure resistance between terminals of power switch. Terminals No. 3 — No. 4:	Is the resistance more than 1 M Ω ?	Go to step 7.	Repair power switch.
7	CHECK HARNESS CONNECTOR BETWEEN TCM AND POWER SWITCH. Measure resistance of harness connector between TCM and power switch. Connector & terminal (B55) No. 23 — (B116) No. 3:	Is the resistance less than 1 Ω ?	Go to step 8.	Repair open circuit in harness between TCM and power switch connector.
8	CHECK HARNESS CONNECTOR BETWEEN TCM AND POWER SWITCH. Measure resistance of harness connector between TCM and chassis ground. Connector & terminal (B55) No. 23 — Chassis ground:	Is the resistance more than 1 M Ω ?	Go to step 9.	Repair short circuit in harness between TCM and power switch connector.
9	CHECK INPUT SIGNAL FOR TCM. 1) Connect connectors to TCM and power switch. 2) Turn ignition switch ON (with engine OFF). 3) Measure signal voltage for TCM while turning power switch OFF. Connector & terminal (B55) No. 23 (+) — Chassis ground (-):	Is the voltage more than 10 V?	Go to step 10.	Replace TCM. <Ref. to AT-48, Transmission Control Module (TCM).>

DIAGNOSTIC PROCEDURE FOR NO-TROUBLE CODE

Automatic Transmission (Diagnostics)

No.	Step	Check	Yes	No
10	CHECK INPUT SIGNAL FOR TCM. Measure signal voltage for TCM while turning power switch ON. Connector & terminal (B55) No. 23 (+) — Chassis ground (-):	Is the voltage less than 1 V?	Go to step 11.	Replace TCM. <Ref. to AT-48, Transmission Control Module (TCM).>
11	CHECK POOR CONTACT.	Is there poor contact?	Repair poor contact.	A temporary poor contact of the connector or harness in power switch circuit.

DIAGNOSTIC PROCEDURE FOR NO-TROUBLE CODE

Automatic Transmission (Diagnostics)

MEMO:

DIAGNOSTIC PROCEDURE FOR NO-TROUBLE CODE

Automatic Transmission (Diagnostics)

H: CHECK INHIBITOR SWITCH. S004618F20

DIAGNOSIS:

Input signal circuit of inhibitor switch is open or shorted.

TROUBLE SYMPTOM:

- Shift characteristics are erroneous.
- Engine brake is not effected when selector lever is in "3" range.
- Engine brake is not effected when selector lever is in "2" range.
- Engine brake is not effected when selector lever is in "1" range.

DIAGNOSTIC PROCEDURE FOR NO-TROUBLE CODE

Automatic Transmission (Diagnostics)

WIRING DIAGRAM:

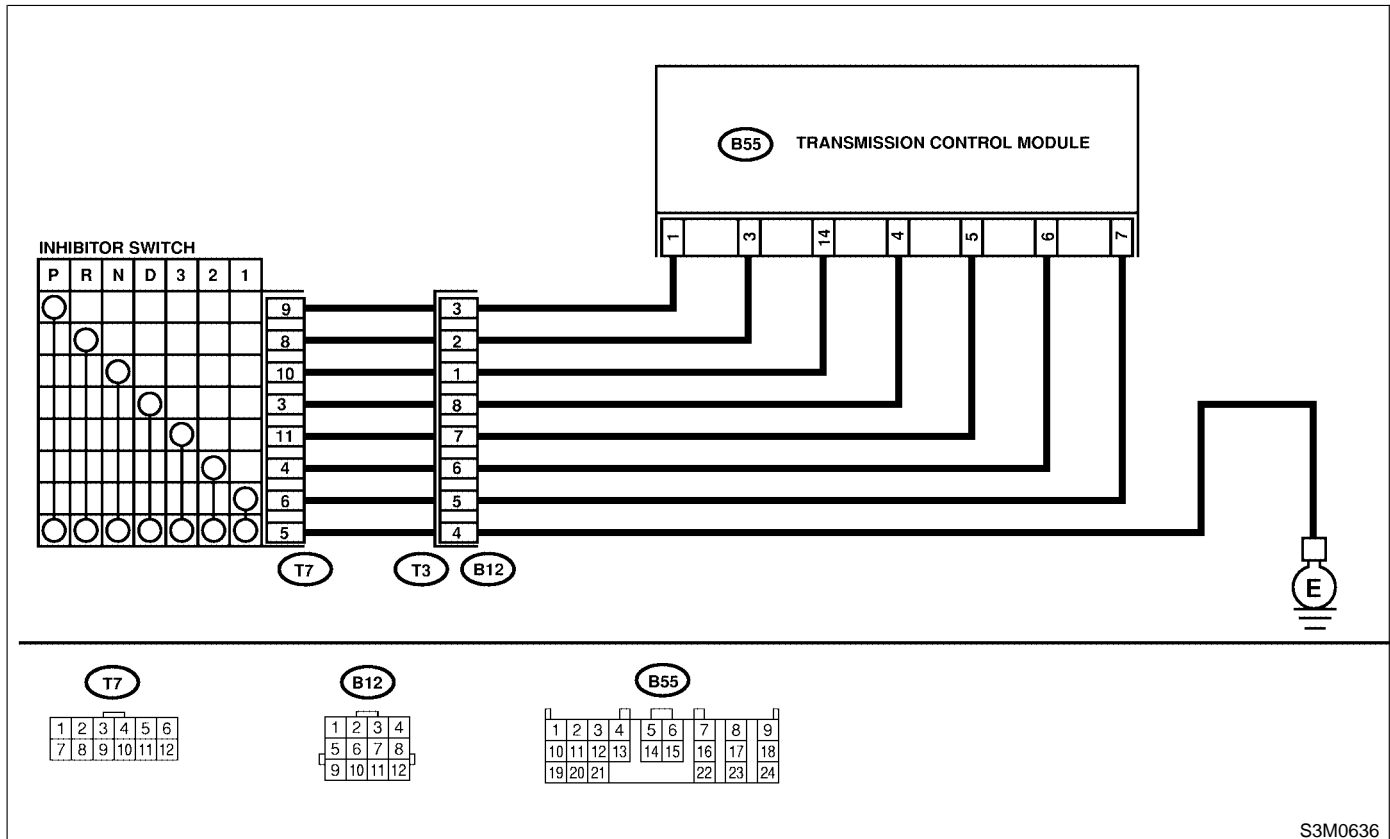

No.	Step	Check	Yes	No
1	CHECK "P" RANGE SWITCH.	When "P" range is selected, does LED light up?	Go to step 2.	Go to step 15.
2	CHECK "P" RANGE SWITCH.	When the "R" range is selected, does "P" range LED light up?	Go to step 19.	Go to step 3.
3	CHECK "R" RANGE SWITCH.	When the "R" range is selected, does LED light up?	Go to step 4.	Go to step 20.
4	CHECK "R" RANGE SWITCH.	When the "N" range is selected, does "R" range LED light up?	Go to step 23.	Go to step 5.
5	CHECK "N" RANGE SWITCH.	When the "N" range is selected, does LED light up?	Go to step 6.	Go to step 24.
6	CHECK "N" RANGE SWITCH.	When the "D" range is selected, does "N" range LED light up?	Go to step 27.	Go to step 7.
7	CHECK "D" RANGE SWITCH.	When the "D" range is selected, does LED light up?	Go to step 8.	Go to step 28.
8	CHECK "D" RANGE SWITCH.	When the "3" range is selected, does "D" range LED light up?	Go to step 31.	Go to step 9.
9	CHECK "3" RANGE SWITCH.	When the "3" range is selected, does LED light up?	Go to step 10.	Go to step 32.

DIAGNOSTIC PROCEDURE FOR NO-TROUBLE CODE

Automatic Transmission (Diagnostics)

No.	Step	Check	Yes	No
10	CHECK "3" RANGE SWITCH.	When the "2" range is selected, does "3" range LED light up?	Go to step 35.	Go to step 11.
11	CHECK "2" RANGE SWITCH.	When the "2" range is selected, does LED light up?	Go to step 12.	Go to step 36.
12	CHECK "2" RANGE SWITCH.	When the "1" range is selected, does "2" range LED light up?	Go to step 39.	Go to step 13.
13	CHECK "1" RANGE SWITCH.	When the "1" range is selected, does LED light up?	Go to step 14.	Go to step 40.
14	CHECK "1" RANGE SWITCH.	When the "P" range is selected, does "1" range LED light UP?	Go to step 43.	Go to step CHECK HOLD SWITCH. <Ref. to AT-130, CHECK HOLD SWITCH., Diagnostic Procedure for No-trouble Code.>
15	CHECK HARNESS CONNECTOR BETWEEN INHIBITOR SWITCH AND CHASSIS GROUND. 1) Turn ignition switch to OFF. 2) Disconnect connector from inhibitor switch. 3) Measure resistance of harness between inhibitor switch and chassis ground. Connector & terminal (T7) No. 5 — Chassis ground:	Is the resistance less than 1 Ω ?	Go to step 16.	Repair open circuit in harness between inhibitor switch connector and chassis ground, and poor contact in coupling connector.
16	CHECK HARNESS CONNECTOR BETWEEN TCM AND INHIBITOR SWITCH. 1) Turn ignition switch to OFF. 2) Disconnect connectors from TCM and inhibitor switch. 3) Measure resistance of harness between TCM and inhibitor switch connector. Connector & terminal (B55) No. 1 — (T7) No. 9	Is the resistance less than 1 Ω ?	Go to step 17.	Repair open circuit in harness between TCM and inhibitor switch connector, and poor contact in coupling connector.
17	CHECK INPUT SIGNAL FOR TCM. 1) Turn ignition switch to OFF. 2) Connect connector to TCM and inhibitor switch. 3) Turn ignition switch to ON. 4) Measure voltage between TCM and chassis ground. Connector & terminal (B55) No. 1 (+) — Chassis ground (-):	Is the voltage less than 1 V in "P" range?	Go to step 18.	Go to step 44.
18	CHECK INPUT SIGNAL FOR TCM. Measure voltage between TCM and chassis ground. Connector & terminal (B55) No. 1 (+) — Chassis ground (-):	Is the voltage more than 8 V in other ranges?	Go to step 44.	Replace TCM. <Ref. to AT-48, Transmission Control Module (TCM).>

DIAGNOSTIC PROCEDURE FOR NO-TROUBLE CODE

Automatic Transmission (Diagnostics)

No.	Step	Check	Yes	No
19	CHECK HARNESS CONNECTOR BETWEEN TCM AND INHIBITOR SWITCH. 1) Turn ignition switch to OFF. 2) Disconnect connectors from TCM, inhibitor switch and combination meter. 3) Measure resistance of harness between TCM and chassis ground. Connector & terminal (B55) No. 1 — Chassis ground:	Is the resistance less than 1 M Ω ?	Go to step 20.	Repair ground short circuit in "P" range circuit.
20	CHECK HARNESS CONNECTOR BETWEEN TCM AND INHIBITOR SWITCH. 1) Turn ignition switch to OFF. 2) Disconnect connectors from TCM and inhibitor switch. 3) Measure resistance of harness between TCM and inhibitor switch connector. Connector & terminal (B55) No. 3 — (T7) No. 8:	Is the resistance less than 1 Ω ?	Go to step 21.	Repair open circuit in harness between TCM and inhibitor switch connector, and poor contact in coupling connector.
21	CHECK INPUT SIGNAL FOR TCM. 1) Turn ignition switch to OFF. 2) Connect connector to TCM and inhibitor switch. 3) Turn ignition switch to ON. 4) Measure voltage between TCM and chassis ground. Connector & terminal (B55) No. 3 (+) — Chassis ground (-):	Is the voltage less than 1 V in "R" range?	Go to step 22.	Go to step 44.
22	CHECK INPUT SIGNAL FOR TCM. Measure voltage between TCM and chassis ground. Connector & terminal (B55) No. 3 (+) — Chassis ground (-):	Is the voltage more than 8 V in other ranges?	Go to step 44.	Replace TCM. <Ref. to AT-48, Transmission Control Module (TCM).>
23	CHECK HARNESS CONNECTOR BETWEEN TCM AND INHIBITOR SWITCH. 1) Turn ignition switch to OFF. 2) Disconnect connectors from TCM, inhibitor switch and combination meter. 3) Measure resistance of harness between TCM and chassis ground. Connector & terminal (B55) No. 3 — Chassis ground:	Is the resistance more than 1 M Ω ?	Go to step 24.	Repair ground short circuit in "R" range circuit.
24	CHECK HARNESS CONNECTOR BETWEEN TCM AND INHIBITOR SWITCH. 1) Turn ignition switch to OFF. 2) Disconnect connectors from TCM and inhibitor switch. 3) Measure resistance of harness between TCM and inhibitor switch connector. Connector & terminal (B55) No. 14 — (T7) No. 10:	Is the resistance less than 1 Ω ?	Go to step 25.	Repair open circuit in harness between TCM and inhibitor switch connector, and poor contact in coupling connector.
25	CHECK INPUT SIGNAL FOR TCM. 1) Turn ignition switch to OFF. 2) Connect connector to TCM and inhibitor switch. 3) Turn ignition switch to ON. 4) Measure voltage between TCM and chassis ground. Connector & terminal (B55) No. 14 (+) — Chassis ground (-):	Is the voltage less than 1 V in "N" range?	Go to step 26.	Go to step 44.

DIAGNOSTIC PROCEDURE FOR NO-TROUBLE CODE

Automatic Transmission (Diagnostics)

No.	Step	Check	Yes	No
26	CHECK INPUT SIGNAL FOR TCM. Measure voltage between TCM and chassis ground. <i>Connector & terminal</i> <i>(B55) No. 14 (+) — Chassis ground (-):</i>	Is the voltage more than 8 V in other ranges?	Go to step 44.	Replace TCM. <Ref. to AT-48, Transmission Control Module (TCM).>
27	CHECK HARNESS CONNECTOR BETWEEN TCM AND INHIBITOR SWITCH. 1) Turn ignition switch to OFF. 2) Disconnect connectors from TCM, inhibitor switch and combination meter. 3) Measure resistance of harness between TCM and chassis ground. <i>Connector & terminal</i> <i>(B55) No. 14 — Chassis ground:</i>	Is the resistance more than 1 M Ω ?	Go to step 28.	Repair ground short circuit in "N" range circuit.
28	CHECK HARNESS CONNECTOR BETWEEN TCM AND INHIBITOR SWITCH. 1) Turn ignition switch to OFF. 2) Disconnect connectors from TCM and inhibitor switch. 3) Measure resistance of harness between TCM and inhibitor switch connector. <i>Connector & terminal</i> <i>(B55) No. 4 — (T7) No. 3:</i>	Is the resistance less than 1 Ω ?	Go to step 29.	Repair open circuit in harness between TCM and inhibitor switch connector, and poor contact in coupling connector.
29	CHECK INPUT SIGNAL FOR TCM. 1) Turn ignition switch to OFF. 2) Connect connector to TCM and inhibitor switch. 3) Turn ignition switch to ON. 4) Measure voltage between TCM and chassis ground. <i>Connector & terminal</i> <i>(B55) No. 4 (+) — Chassis ground (-):</i>	Is the voltage less than 1 V in "D" range?	Go to step 30.	Go to step 44.
30	CHECK INPUT SIGNAL FOR TCM. Measure voltage between TCM and chassis ground. <i>Connector & terminal</i> <i>(B55) No. 4 (+) — Chassis ground (-):</i>	Is the voltage more than 8 V in other ranges?	Go to step 44.	Replace TCM. <Ref. to AT-48, Transmission Control Module (TCM).>
31	CHECK HARNESS CONNECTOR BETWEEN TCM AND INHIBITOR SWITCH. 1) Turn ignition switch to OFF. 2) Disconnect connectors from TCM, inhibitor switch and combination meter. 3) Measure resistance of harness between TCM and chassis ground. <i>Connector & terminal</i> <i>(B55) No. 4 — Chassis ground:</i>	Is the resistance more than 1 M Ω ?	Go to step 32.	Repair ground short circuit in "D" range circuit.
32	CHECK HARNESS CONNECTOR BETWEEN TCM AND INHIBITOR SWITCH. 1) Turn ignition switch to OFF. 2) Disconnect connector from TCM and inhibitor switch. 3) Measure resistance of harness between TCM and inhibitor switch connector. <i>Connector & terminal</i> <i>(B55) No. 5 — (T7) No. 11:</i>	Is the resistance less than 1 Ω ?	Go to step 33.	Repair open circuit in harness between TCM and inhibitor switch connector, and poor contact in coupling connector.

DIAGNOSTIC PROCEDURE FOR NO-TROUBLE CODE

Automatic Transmission (Diagnostics)

No.	Step	Check	Yes	No
33	CHECK INPUT SIGNAL FOR TCM. 1) Turn ignition switch to OFF. 2) Connect connector to TCM and inhibitor switch. 3) Turn ignition switch to ON. 4) Measure voltage between TCM and chassis ground. Connector & terminal (B55) No. 5 (+) — Chassis ground (-):	Is the voltage less than 1 V in "3" range?	Go to step 34.	Go to step 44.
34	CHECK INPUT SIGNAL FOR TCM. Measure voltage between TCM and chassis ground. Connector & terminal (B55) No. 5 (+) — Chassis ground (-):	Is the voltage more than 8 V in other ranges?	Go to step 44.	Replace TCM. <Ref. to AT-48, Transmission Control Module (TCM).>
35	CHECK HARNESS CONNECTOR BETWEEN TCM AND INHIBITOR SWITCH. 1) Turn ignition switch to OFF. 2) Disconnect connectors from TCM, inhibitor switch and combination meter. 3) Measure resistance of harness between TCM and chassis ground. Connector & terminal (B55) No. 5 — Chassis ground:	Is the resistance more than 1 M Ω ?	Go to step 36.	Repair ground short circuit in "3" range circuit.
36	CHECK HARNESS CONNECTOR BETWEEN TCM AND INHIBITOR SWITCH. 1) Turn ignition switch to OFF. 2) Disconnect connector from TCM and inhibitor switch. 3) Measure resistance of harness between TCM and inhibitor switch connector. Connector & terminal (B55) No. 6 — (T7) No. 4:	Is the resistance less than 1 Ω ?	Go to step 37.	Repair open circuit in harness between TCM and inhibitor switch connector, and poor contact in coupling connector.
37	CHECK INPUT SIGNAL FOR TCM. 1) Turn ignition switch to OFF. 2) Connect connector to TCM and inhibitor switch. 3) Turn ignition switch to ON. 4) Measure voltage between TCM and chassis ground. Connector & terminal (B55) No. 6 (+) — Chassis ground (-):	Is the voltage less than 1 V in "2" range?	Go to step 38.	Go to step 44.
38	CHECK INPUT SIGNAL FOR TCM. Measure voltage between TCM and chassis ground. Connector & terminal (B55) No. 6 (+) — Chassis ground (-):	Is the voltage more than 8 V in other ranges?	Go to step 44.	Replace TCM. <Ref. to AT-48, Transmission Control Module (TCM).>
39	CHECK HARNESS CONNECTOR BETWEEN TCM AND INHIBITOR SWITCH. 1) Turn ignition switch to OFF. 2) Disconnect connectors from TCM, inhibitor switch and combination meter. 3) Measure resistance of harness between TCM and chassis ground. Connector & terminal (B55) No. 6 — Chassis ground:	Is the resistance more than 1 M Ω ?	Go to step 40.	Repair ground short circuit in "2" range circuit.

DIAGNOSTIC PROCEDURE FOR NO-TROUBLE CODE

Automatic Transmission (Diagnostics)

No.	Step	Check	Yes	No
40	CHECK HARNESS CONNECTOR BETWEEN TCM AND INHIBITOR SWITCH. 1) Turn ignition switch to OFF. 2) Disconnect connectors from TCM and inhibitor switch. 3) Measure resistance of harness between TCM and inhibitor switch connector. Connector & terminal (B55) No. 7 — (T7) No. 6:	Is the resistance less than 1 Ω ?	Go to step 41.	Repair open circuit in harness between TCM and inhibitor switch connector, and poor contact in coupling connector.
41	CHECK INPUT SIGNAL FOR TCM. 1) Turn ignition switch to OFF. 2) Connect connector to TCM and inhibitor switch. 3) Turn ignition switch to ON. 4) Measure voltage between TCM and chassis ground. Connector & terminal (B55) No. 7 (+) — Chassis ground (-):	Is the voltage less than 1 V in "1" range?	Go to step 42.	Go to step 44.
42	CHECK INPUT SIGNAL FOR TCM. Measure voltage between TCM and chassis ground. Connector & terminal (B55) No. 7 (+) — Chassis ground (-):	Is the voltage more than 8 V in other ranges?	Go to step 44.	Replace TCM. <Ref. to AT-48, Transmission Control Module (TCM).>
43	CHECK HARNESS CONNECTOR BETWEEN TCM AND INHIBITOR SWITCH. 1) Turn ignition switch to OFF. 2) Disconnect connectors from TCM, inhibitor switch and combination meter. 3) Measure resistance of harness between TCM and chassis ground. Connector & terminal (B55) No. 7 — Chassis ground:	Is the resistance more than 1 M Ω ?	Go to step 44.	Repair ground short circuit in "1" range circuit.
44	CHECK POOR CONTACT.	Is there poor contact in inhibitor switch circuit?	Repair poor contact.	Adjust inhibitor switch and select cable or replace TCM. <Ref. to AT-28, ADJUSTMENT, Inhibitor Switch.> and <Ref. to CS-10, Select Cable.> <Ref. to AT-48, Transmission Control Module (TCM).>

DIAGNOSTIC PROCEDURE FOR NO-TROUBLE CODE

Automatic Transmission (Diagnostics)

MEMO:

DIAGNOSTIC PROCEDURE FOR NO-TROUBLE CODE

Automatic Transmission (Diagnostics)

I: CHECK HOLD SWITCH. S004618G78

DIAGNOSIS:

- LED does not come on when hold switch is ON.
- Hold switch circuit is open or shorted.

TROUBLE SYMPTOM:

- 2nd gear is not held.
- Failure of vehicle to start in 2nd gear except 1st range.

DIAGNOSTIC PROCEDURE FOR NO-TROUBLE CODE

Automatic Transmission (Diagnostics)

WIRING DIAGRAM:

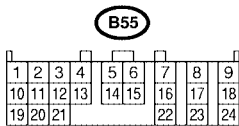
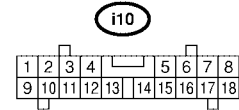
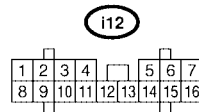
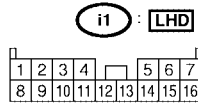
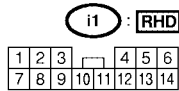
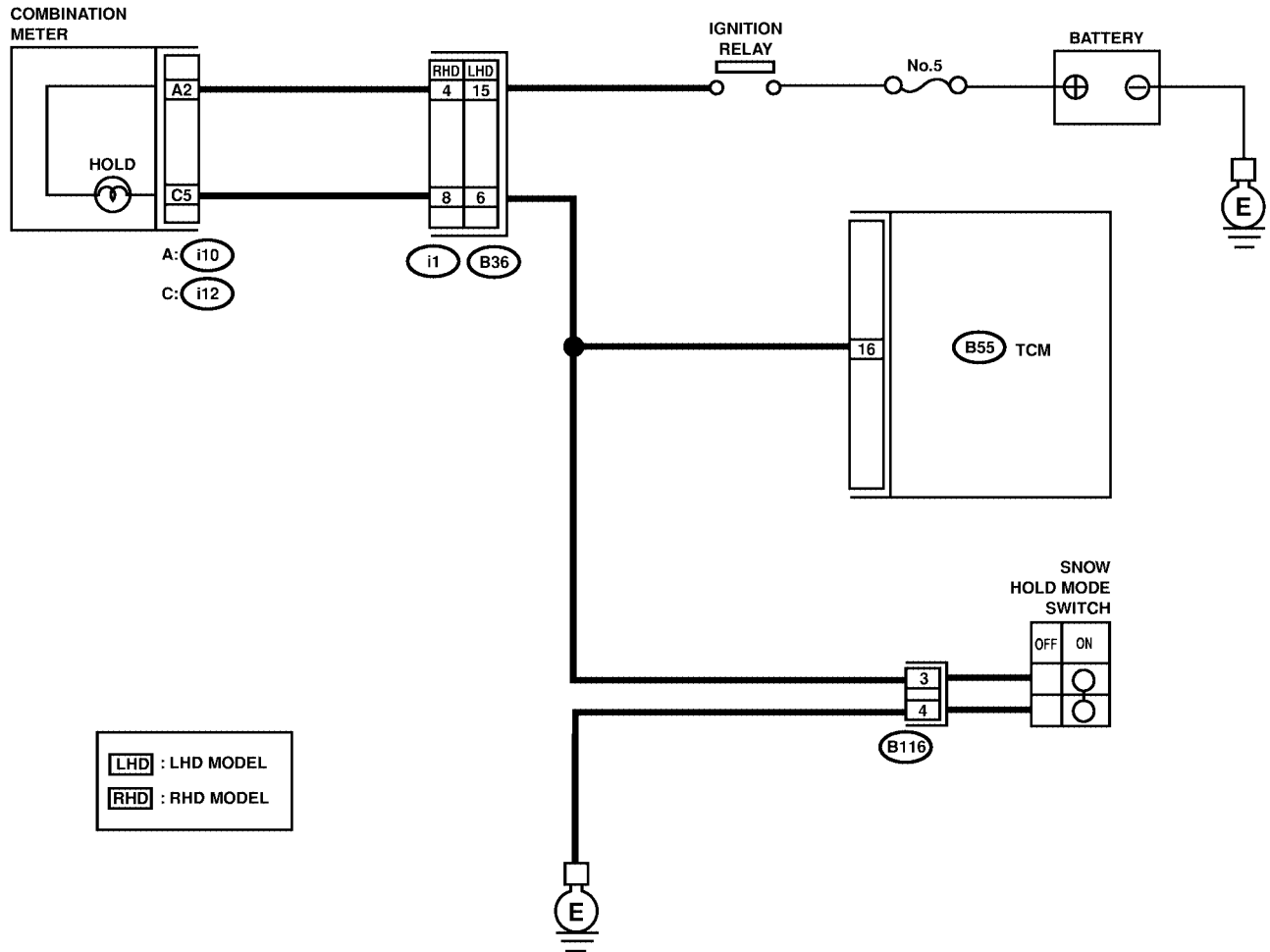

S3M0637

DIAGNOSTIC PROCEDURE FOR NO-TROUBLE CODE

Automatic Transmission (Diagnostics)

No.	Step	Check	Yes	No
1	CHECK HOLD SWITCH OPERATION.	When hold switch is turned OFF, does LED light up?	Go to step 5.	Go to step 2.
2	CHECK HOLD SWITCH OPERATION.	When hold switch is turned ON, does LED light up?	Go to step Symptom Related Diagnostic. <Ref. 134, Symptom Related Diagnostic.>	Go to step 3.
3	CHECK HOLD INDICATOR LIGHT. 1) Turn ignition switch to OFF. 2) Remove combination meter. 3) Remove HOLD indicator light bulb from combination meter.	Is HOLD indicator light bulb OK?	Go to step 4.	Replace HOLD indicator light bulb. <Ref. to IDI-15, Combination Meter Assembly.>
4	CHECK HOLD SWITCH GROUND LINE. 1) Turn ignition switch to OFF. 2) Disconnect connector from hold switch. 3) Measure resistance of harness connector between hold switch and chassis ground. Connector & terminal (B116) No. 4 — Chassis ground:	Is the resistance less than 1 Ω ?	Go to step 5.	Repair open circuit in harness between hold switch and chassis ground.
5	CHECK HOLD SWITCH. 1) Hold switch turned ON. 2) Measure resistance between terminals of hold switch. Terminals No. 4 — No. 3:	Is the resistance less than 1 Ω ?	Go to step 6.	Repair hold switch.
6	CHECK HOLD SWITCH. 1) Hold switch turned OFF. 2) Measure resistance between terminals of hold switch. Terminals No. 4 — No. 3:	Is the resistance more than 1 M Ω ?	Go to step 7.	Repair hold switch.
7	CHECK HARNESS CONNECTOR BETWEEN TCM AND HOLD SWITCH. 1) Disconnect connector TCM and combination meter. 2) Measure resistance of harness connector between TCM and hold switch. Connector & terminal (B55) No. 16 — (B116) No. 3:	Is the resistance less than 1 Ω ?	Go to step 8.	Repair open circuit in harness between TCM and hold switch connector and poor contact in coupling connector.
8	CHECK HARNESS CONNECTOR BETWEEN TCM AND COMBINATION METER. Measure resistance of harness connector TCM and combination meter. Connector & terminal (B55) No. 16 — (i12) No. 5:	Is the resistance less than 1 Ω ?	Go to step 9.	Repair open circuit in harness between TCM and combination meter, and poor contact in coupling connector.
9	CHECK HARNESS CONNECTOR BETWEEN TCM AND HOLD SWITCH. Measure resistance of harness connector between TCM and chassis ground to make sure that circuit does not short. Connector & terminal (B55) No. 16 — Chassis ground:	Is the resistance more than 1 M Ω ?	Go to step 10.	Repair short circuit in harness between TCM, hold switch and combination meter connector.

DIAGNOSTIC PROCEDURE FOR NO-TROUBLE CODE

Automatic Transmission (Diagnostics)

No.	Step	Check	Yes	No
10	CHECK INPUT SIGNAL FOR TCM. 1) Connect connectors to TCM and hold switch. 2) Turn ignition switch ON (with engine OFF). 3) Measure signal voltage for TCM while turning hold switch OFF. Connector & terminal (B55) No. 16 (+) — Chassis ground (-):	Is the voltage more than 8 V?	Go to step 11.	Replace TCM. <Ref. to AT-48, Transmission Control Module (TCM).>
11	CHECK INPUT SIGNAL FOR TCM. Measure signal voltage for TCM while turning hold switch ON. Connector & terminal (B55) No. 16 (+) — Chassis ground (-):	Is the voltage less than 1 V?	Go to step 12.	Replace TCM. <Ref. to AT-48, Transmission Control Module (TCM).>
12	CHECK POOR CONTACT.	Is there poor contact?	Repair poor contact.	A temporary poor contact of the connector or harness or connector in hold switch circuit.

SYMPTOM RELATED DIAGNOSTIC

Automatic Transmission (Diagnostics)

16. Symptom Related Diagnostic S004519

A: INSPECTION S004519A10

Symptom	Problem parts
Starter does not rotate when select lever is in "P" or "N"; starter rotates when select lever is in "R", "D", "3" or "2".	<ul style="list-style-type: none"> ● Inhibitor switch ● Select cable ● Select lever ● Starter motor and harness
Abnormal noise when select lever is in "P" or "N".	<ul style="list-style-type: none"> ● Strainer ● Transfer duty solenoid ● Oil pump ● Drive plate ● ATF level too high or too low
Hissing noise occurs during standing start.	<ul style="list-style-type: none"> ● Strainer ● ATF level too high or too low
Noise occurs while driving in "D1".	<ul style="list-style-type: none"> ● Final gear ● Planetary gear ● Reduction gear ● Differential gear oil level too high or too low
Noise occurs while driving in "D2".	
Noise occurs while driving in "D3".	<ul style="list-style-type: none"> ● Final gear ● Low & reverse brake ● Reduction gear ● Differential gear oil level too high or too low
Noise occurs while driving in "D4".	<ul style="list-style-type: none"> ● Final gear ● Low & reverse brake ● Planetary gear ● Reduction gear ● Differential gear oil level too high or too low
Engine stalls while shifting from one range to another.	<ul style="list-style-type: none"> ● Control valve ● Lock-up damper ● Engine performance ● Input shaft
Vehicle moves when select lever is in "N".	<ul style="list-style-type: none"> ● TCM ● Low clutch
Shock occurs when select lever is moved from "N" to "D".	<ul style="list-style-type: none"> ● TCM ● Harness ● Control valve ● ATF deterioration
Excessive time lag occurs when select lever is moved from "N" to "D".	<ul style="list-style-type: none"> ● Control valve ● Low clutch ● Line pressure duty solenoid ● Seal ring ● Front gasket transmission case
Shock occurs when select lever is moved from "N" to "R".	<ul style="list-style-type: none"> ● TCM ● Harness ● Control valve ● ATF deterioration
Excessive time lag occurs when select lever is moved from "N" to "R".	<ul style="list-style-type: none"> ● Control valve ● Low & reverse clutch ● Reverse clutch ● Line pressure duty solenoid ● Seal ring ● Front gasket transmission case
Vehicle does not start in any shift range (engine stalls).	<ul style="list-style-type: none"> ● Parking brake mechanism ● Planetary gear

SYMPTOM RELATED DIAGNOSTIC

Automatic Transmission (Diagnostics)

Symptom	Problem parts
Vehicle does not start in any shift range (engine revving up).	<ul style="list-style-type: none"> ● Strainer ● Line pressure duty solenoid ● Control valve ● Drive pinion ● Hypoid gear ● Axle shaft ● Differential gear ● Oil pump ● Input shaft ● Output shaft ● Planetary gear ● Drive plate ● ATF level too low ● Front gasket transmission case
Vehicle does not start in "R" range only (engine revving up).	<ul style="list-style-type: none"> ● Select cable ● Select lever ● Control valve ● Low & reverse clutch ● Reverse clutch
Vehicle does not start in "R" range only (engine stalls).	<ul style="list-style-type: none"> ● Low clutch ● 2-4 brake ● Planetary gear ● Parking brake mechanism
Vehicle does not start in "D", "3" range only (engine revving up).	<ul style="list-style-type: none"> ● Low clutch ● One-way clutch
Vehicle does not start in "D", "3" or "2" range only (engine revving up).	<ul style="list-style-type: none"> ● Low clutch
Vehicle does not start in "D", "3" or "2" range only (engine stalls).	<ul style="list-style-type: none"> ● Reverse clutch
Vehicle starts in "R" range only (engine revving up).	<ul style="list-style-type: none"> ● Control valve
Acceleration during standing starts is poor (high stall rpm).	<ul style="list-style-type: none"> ● Control valve ● Low clutch ● Reverse clutch ● ATF level too low ● Front gasket transmission case ● Differential gear oil level too high or too low
Acceleration during standing starts is poor (low stall rpm).	<ul style="list-style-type: none"> ● Oil pump ● Torque converter one-way clutch ● Engine performance
Acceleration is poor when select lever is in "D", "3" or "2" range (normal stall rpm).	<ul style="list-style-type: none"> ● TCM ● Control valve ● High clutch ● 2-4 brake ● Planetary gear
Acceleration is poor when select lever is in "R" (normal stall rpm).	<ul style="list-style-type: none"> ● Control valve ● High clutch ● 2-4 brake ● Planetary gear
No shift occurs from 1st to 2nd gear.	<ul style="list-style-type: none"> ● TCM ● Rear vehicle speed sensor ● Front vehicle speed sensor ● Throttle position sensor ● Shift solenoid 1 ● Control valve ● 2-4 brake
No shift occurs from 2nd to 3rd gear.	<ul style="list-style-type: none"> ● TCM ● Control valve ● High clutch ● Shift solenoid 2

SYMPTOM RELATED DIAGNOSTIC

Automatic Transmission (Diagnostics)

Symptom	Problem parts
No shift occurs from 3rd to 4th gear.	<ul style="list-style-type: none"> ● TCM ● Shift solenoid 1 ● ATF temperature sensor ● Control valve ● 2-4 brake
Engine brake is not effected when select lever is in "3" range.	<ul style="list-style-type: none"> ● Inhibitor switch ● TCM ● Throttle position sensor ● Control valve
Engine brake is not effected when select lever is in "3" or "2" range.	<ul style="list-style-type: none"> ● Control valve
Engine brake is not effected when select lever is in "1" range.	<ul style="list-style-type: none"> ● Control valve ● Low & reverse brake
Shift characteristics are erroneous.	<ul style="list-style-type: none"> ● Inhibitor switch ● TCM ● Front vehicle speed sensor ● Rear vehicle speed sensor ● Throttle position sensor ● Control valve ● Ground earth
No lock-up occurs.	<ul style="list-style-type: none"> ● TCM ● Throttle position sensor ● ATF temperature sensor ● Control valve ● Lock-up facing ● Engine speed signal
Parking brake is not effected.	<ul style="list-style-type: none"> ● Select cable ● Select lever ● Parking mechanism
Shift lever cannot be moved or is hard to move from "P" range.	
ATF spurts out.	<ul style="list-style-type: none"> ● ATF level too high
Differential oil spurts out.	<ul style="list-style-type: none"> ● Differential gear oil too high
Differential oil level changes excessively.	<ul style="list-style-type: none"> ● Seal pipe ● Double oil seal
Odor is produced from ATF supply pipe.	<ul style="list-style-type: none"> ● High clutch ● 2-4 brake ● Low & reverse clutch ● Reverse clutch ● Lock-up facing ● ATF deterioration
Shock occurs from 1st to 2nd gear.	<ul style="list-style-type: none"> ● TCM ● Throttle position sensor ● 2-4 brake duty solenoid ● ATF temperature sensor ● Line pressure duty solenoid ● Control valve ● 2-4 brake ● ATF deterioration ● Engine performance ● 2-4 brake timing solenoid
Slippage occurs from 1st to 2nd gear.	<ul style="list-style-type: none"> ● TCM ● Throttle position sensor ● 2-4 brake duty solenoid ● ATF temperature sensor ● Line pressure duty solenoid ● Control valve ● 2-4 brake ● 2-4 brake timing solenoid ● High clutch

SYMPTOM RELATED DIAGNOSTIC

Automatic Transmission (Diagnostics)

Symptom	Problem parts
Shock occurs from 2nd to 3rd gear.	<ul style="list-style-type: none"> ● TCM ● Throttle position sensor ● 2-4 brake duty solenoid ● ATF temperature sensor ● Line pressure duty solenoid ● Control valve ● High clutch ● 2-4 brake ● ATF deterioration ● Engine performance ● 2-4 brake timing solenoid
Slippage occurs from 2nd to 3rd gear.	<ul style="list-style-type: none"> ● TCM ● Throttle position sensor ● 2-4 brake duty solenoid ● ATF temperature sensor ● Line pressure duty solenoid ● Control valve ● High clutch ● 2-4 brake ● 2-4 brake timing solenoid
Shock occurs from 3rd to 4th gear.	<ul style="list-style-type: none"> ● TCM ● Throttle position sensor ● 2-4 brake duty solenoid ● ATF temperature sensor ● Line pressure duty solenoid ● Control valve ● 2-4 brake timing solenoid ● 2-4 brake ● ATF deterioration ● Engine performance ● Low clutch timing solenoid ● Low clutch
Slippage occurs from 3rd to 4th gear.	<ul style="list-style-type: none"> ● TCM ● Throttle position sensor ● 2-4 brake duty solenoid ● ATF temperature sensor ● Line pressure duty solenoid ● Control valve ● 2-4 brake ● 2-4 brake timing solenoid
Shock occurs when select lever is moved from "3" to "2" range.	<ul style="list-style-type: none"> ● TCM ● Throttle position sensor ● ATF temperature sensor ● Line pressure duty solenoid ● Control valve ● 2-4 brake duty solenoid ● 2-4 brake ● ATF deterioration ● 2-4 brake timing solenoid
Shock occurs when select lever is moved from "D" to "1" range.	<ul style="list-style-type: none"> ● TCM ● Throttle position sensor ● ATF temperature sensor ● Line pressure duty solenoid ● Control valve ● ATF deterioration ● 2-4 brake duty solenoid ● 2-4 brake timing solenoid ● Low clutch timing solenoid

SYMPTOM RELATED DIAGNOSTIC

Automatic Transmission (Diagnostics)

Symptom	Problem parts
Shock occurs when select lever is moved from "2" to "1" range.	<ul style="list-style-type: none"> ● TCM ● Throttle position sensor ● ATF temperature sensor ● Line pressure duty solenoid ● Control valve ● Low & reverse clutch ● ATF deterioration ● 2-4 brake duty solenoid ● 2-4 brake timing solenoid ● Low clutch timing solenoid
Shock occurs when accelerator pedal is released at medium speeds.	<ul style="list-style-type: none"> ● TCM ● Throttle position sensor ● ATF temperature sensor ● Line pressure duty solenoid ● Control valve ● Lock-up damper ● Engine performance ● 2-4 brake duty solenoid ● 2-4 brake timing solenoid ● Low clutch timing solenoid
Vibration occurs during straight-forward operation.	<ul style="list-style-type: none"> ● TCM ● Lock-up duty solenoid ● Lock-up facing ● Lock-up damper ● Hold switch
Vibration occurs during turns (tight corner "braking" phenomenon).	<ul style="list-style-type: none"> ● TCM ● Front vehicle speed sensor ● Rear vehicle speed sensor ● Throttle position sensor ● ATF temperature sensor ● Transfer clutch ● Transfer valve ● Transfer duty solenoid ● ATF deterioration ● Harness ● Hold switch
Front wheel slippage occurs during standing starts.	<ul style="list-style-type: none"> ● TCM ● Front vehicle speed sensor ● FWD switch ● Throttle position sensor ● ATF temperature sensor ● Control valve ● Transfer clutch ● Transfer valve ● Transfer pipe ● Transfer duty solenoid
Vehicle is not set in FWD mode.	<ul style="list-style-type: none"> ● TCM ● FWD switch ● Transfer clutch ● Transfer valve ● Transfer duty solenoid
Select lever is hard to move.	<ul style="list-style-type: none"> ● Select cable ● Select lever ● Detent spring ● Manual plate
Select lever is too high to move (unreasonable resistance).	<ul style="list-style-type: none"> ● Detent spring ● Manual plate

SYMPTOM RELATED DIAGNOSTIC

Automatic Transmission (Diagnostics)

Symptom	Problem parts
Select lever slips out of operation during acceleration or while driving on rough terrain.	<ul style="list-style-type: none">● Select cable● Select lever● Detent spring● Manual plate

SYMPTOM RELATED DIAGNOSTIC

Automatic Transmission (Diagnostics)

MEMO: