

WIRING SYSTEM SECTION**WIRING SYSTEM****WI**

This service manual has been prepared to provide SUBARU service personnel with the necessary information and data for the correct maintenance and repair of SUBARU vehicles.

This manual includes the procedures for maintenance, disassembling, reassembling, inspection and adjustment of components and diagnostics for guidance of experienced mechanics.

Please peruse and utilize this manual fully to ensure complete repair work for satisfying our customers by keeping their vehicle in optimum condition. When replacement of parts during repair work is needed, be sure to use SUBARU genuine parts.

All information, illustration and specifications contained in this manual are based on the latest product information available at the time of publication approval.

WIRING SYSTEM



	Page
1. Basic Diagnostics Procedure	3
2. Working Precautions	13
3. Power Supply Routing.....	14
4. Ground Distribution	28
5. Airbag System.....	40
6. Air Conditioning System.....	46
7. Anti-lock Brake System.....	50
8. A/T Control System.....	58
9. Audio System	84
10. Back-up Light System	88
11. Charging System.....	89
12. Clearance Light and Illumination Light System	90
13. Combination Meter.....	96
14. Cruise Control System	98
15. Door Lock System.....	104
16. Engine Electrical System	106
17. Front Accessory Power Supply System.....	164
18. Front Fog Light System.....	166
19. Fuel Gauge System	168
20. Full-Time Dual-Range System	170
21. Headlight Beam Leveler System.....	172
22. Headlight System	174
23. Headlight Washer System.....	176
24. Horn System.....	177
25. Immobilizer System	178
26. In Compartment Light System	186
27. Keyless Entry System	190
28. Oil Pressure and Temperature Gauge System.....	196
29. Outside Temperature Display System.....	198
30. Parking Brake and Brake Fluid Level Warning System.....	200
31. Power Window System	202
32. Radiator Fan System	210
33. Rear Accessory Power Supply System.....	211
34. Rear Differential Oil Temperature Warning System.....	212
35. Rear Fog Light System	214
36. Rear Window Defogger System.....	216
37. Remote Controlled Rearview Mirror System	218
38. Seat Belt Warning System	222
39. Seat Heater System.....	224
40. Starter System.....	225
41. Stop Light System.....	226
42. Sunroof System.....	227
43. Turn Signal Light and Hazard Light System.....	228
44. Wiper and Washer System (Front)	232

DIAGNOSTICS CHART WITH TROUBLE CODE

Wiring System

45.	Wiper and Washer System (Rear)	233
46.	Wiper Deicer System	234
47.	Overall Systems	236
48.	Front Wiring Harness	238
49.	Bulkhead Wiring Harness (In Engine Room).....	242
50.	Bulkhead Wiring Harness (In Compartment).....	254
51.	Engine Wiring Harness and Transmission Cord.....	260
52.	Instrument Panel Wiring Harness	266
53.	Rear Wiring Harness.....	270
54.	Door Cord.....	274
55.	Rear Gate Cord.....	278

1. Basic Diagnostics Procedure

S903627

A: BASIC PROCEDURES

S903267E31

1. GENERAL

S903627E3101

The most important purpose of diagnostics is to determine which part is malfunctioning quickly, to save time and labor.

2. IDENTIFICATION OF TROUBLE SYMPTOM

S903627E3102

Determine what the problem is based on the symptom.

3. PROBABLE CAUSE OF TROUBLE

S903627E3103

Look at the wiring diagram and check the system's circuit. Then check the switch, relay, fuse, ground, etc.

4. LOCATION AND REPAIR OF TROUBLE

S903627E3104

- 1) Using the diagnostics narrow down the causes.
- 2) If necessary, use a voltmeter, ohmmeter, etc.
- 3) Before replacing certain component parts (switch, relay, etc.), check the power supply, ground, for open wiring harness, poor connectors, etc. If no problems are encountered, check the component parts.

5. CONFIRMATION OF SYSTEM OPERATION

S903267E3105

After repairing, ensure that the system operates properly.

B: BASIC INSPECTION

S903627G51

1. VOLTAGE MEASUREMENT

S903627G5101

- 1) Using a voltmeter, connect the negative lead to a good ground point or negative battery terminal and the positive lead to the connector or component terminal.
- 2) Contact the positive probe of the voltmeter on connector (A). The voltmeter will indicate a voltage.

- 3) Shift the positive probe to connector (B). The voltmeter will indicate no voltage.

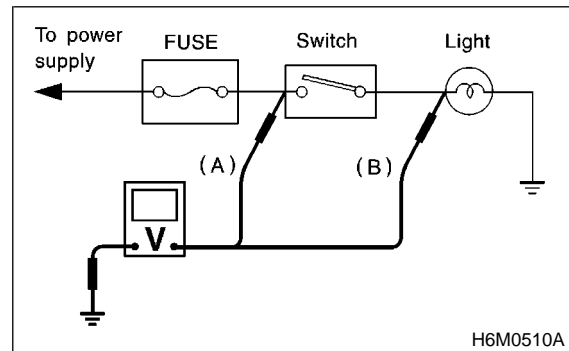

- 4) With test set-up held as it is, turn switch ON. The voltmeter will indicate a voltage and, at the same time, the light will come on.
- 5) The circuit is in good order. If a problem such as a lamp failing to light occurs, use the procedures outlined above to track down the malfunction.

2. CIRCUIT CONTINUITY CHECKS

S903627G5102

- 1) Disconnect the battery terminal or connector so there is no voltage between the check points. Contact the two leads of an ohmmeter to each of the check points. If the circuit has diodes, reverse the two leads and check again.
- 2) Use an ohmmeter to check for diode continuity. When contacting the negative lead to the diode positive side and the positive lead to the negative side, there should be continuity. When contacting the two leads in reverse, there should be no continuity.

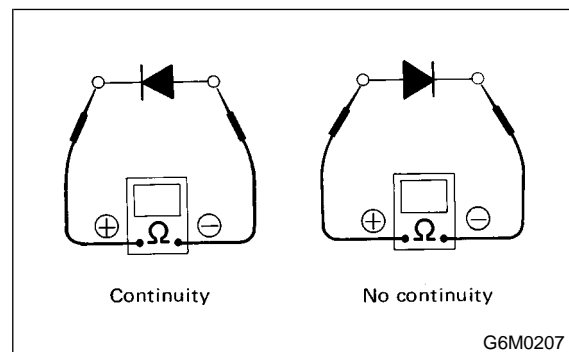

BASIC DIAGNOSTICS PROCEDURE

Wiring System

3) Symbol "○—○" indicates that continuity exists between two points or terminals. For example, when a switch position is "3", continuity exists among terminals 1, 3 and 6, as shown in table below.

Terminal	1	2	3	4	5	6
Switch Position						
OFF						
1	○—○				○—○	
2	○—○			○—○		
3	○—○		○—○			○—○
4	○—○	○—○				

B6M0749

2) Ohmmeter method:
Disconnect all connectors affected, and check continuity in the wiring between adjacent connectors. When the ohmmeter indicates "infinite", the wiring is open.

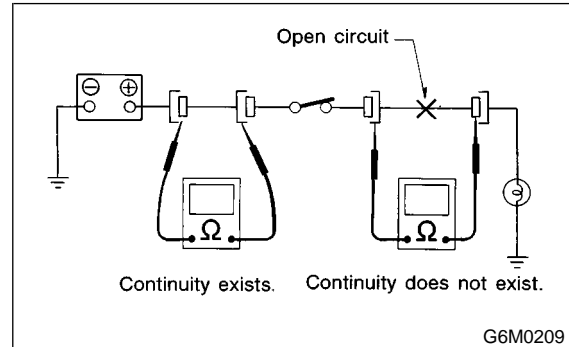

3. HOW TO DETERMINE AN OPEN CIRCUIT

S903627G5103

1) Voltmeter Method:

An open circuit is determined by measuring the voltage between respective connectors and ground using a voltmeter, starting with the connector closest to the power supply. The power supply must be turned ON so that current flows in the circuit. If voltage is not present between a particular connector and ground, the circuit between that connector and the previous connector is open.

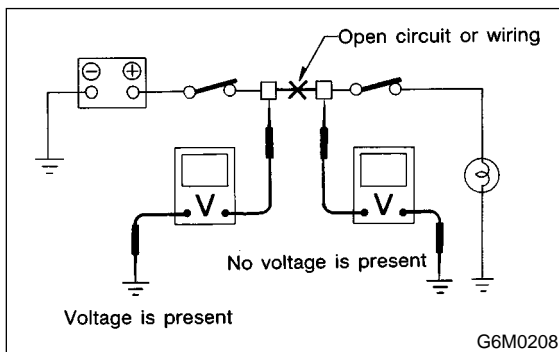

4. HOW TO DETERMINE A SHORT CIRCUIT

S903627G5104

1) Test lamp method:

Connect a test lamp (rated at approximately 3 watts) in place of the blown fuse and allow current to flow through the circuit. Disconnect one connector at a time from the circuit, starting with the one located farthest from the power supply. If the test lamp goes out when a connector is disconnected, the wiring between that connection and the next connector (farther from the power supply) is shorted.

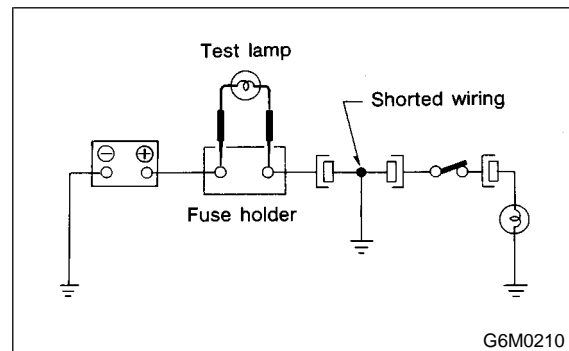

2) Ohmmeter method:

Disconnect all affected connectors, and check continuity between each connector and ground. When ohmmeter indicates continuity between a particular connector and ground, that connector is shorted.

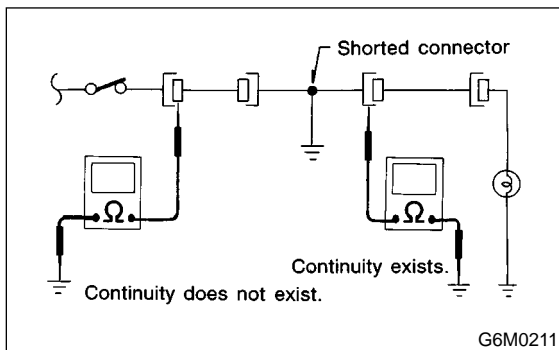

BASIC DIAGNOSTICS PROCEDURE

C: HOW TO READ WIRING DIAGRAMS S903627G52

1. WIRING DIAGRAM S903627G5201

The wiring diagram of each system is illustrated so that you can understand the path through which the electric current flows from the battery.

Sketches and codes are used in the diagrams. They should read as follows:

- Each connector and its terminal position are indicated by a sketch of the connector in a disconnected state which is viewed from the front.

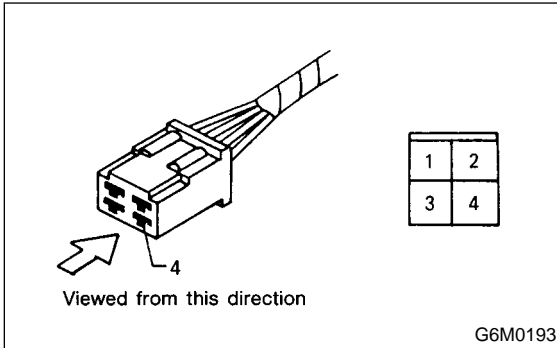

- The number of poles or pins, presence of a lock, and pin number of each terminal are indicated in the sketch of each connector. In the sketch, the highest pole number refers to the number of poles which the connector has. For example, the sketch of the connector shown in figure indicates the connector has 9 poles.

Connector used in vehicle	Connector shown in wiring diagram		
	Sketch	Symbol	Number of poles
<p>G6M0194</p>	<p>Double frames Indicates a lock is included.</p> <p>Indicates the number of poles.</p> <p>G6M0196</p>		<p>Numbered in order from upper right to lower left.</p>
<p>G6M0195</p>	<p>Indicates a lock is included.</p> <p>Single frame</p> <p>G6M0197</p>	<p>G6M0198</p>	<p>Numbered in order from upper left to lower right.</p>

BASIC DIAGNOSTICS PROCEDURE

- When one set of connectors is viewed from the front side, the pole numbers of one connector are symmetrical to those of the other. When these two connectors are connected as a unit, the poles which have the same number are joined.

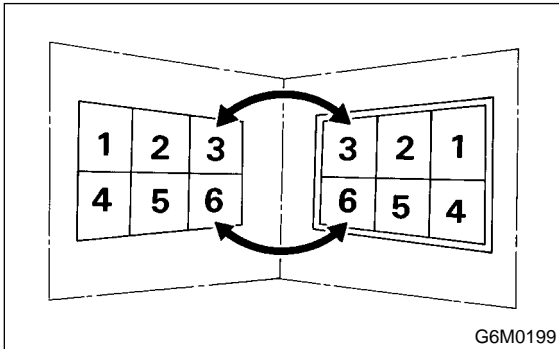

- Electrical wiring harness:**
The connectors are numbered along with the number of poles, external colors, and mating connections in the accompanying list.
- The sketch of each connector in the wiring diagram usually shows the (A) side of the connector. The relationship between the wire color, terminal number and connector is described in figure.

NOTE:

A wire which runs in one direction from a connector terminal sometimes may have a different color from that which runs in the other direction from that terminal.

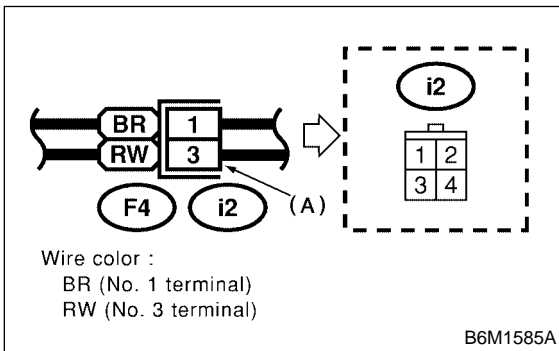

- In wiring diagram, connectors which have no terminal number refer to one-pole types. Sketches of these connectors are omitted intentionally.

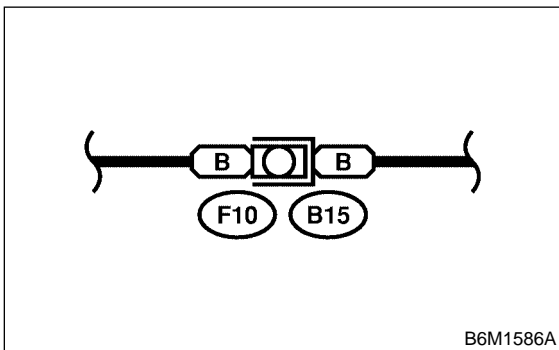

- The following color codes are used to indicate the colors of the wires used.

Color code	Color
L	Blue
B	Black
Y	Yellow
G	Green
R	Red
W	White
Br	Brown
Lg	Light green
Gr	Gray
P	Pink
Or	Orange
Lb	Light Blue
V	Violet
SA	Sealed (Inner)
SB	Sealed (Outer)

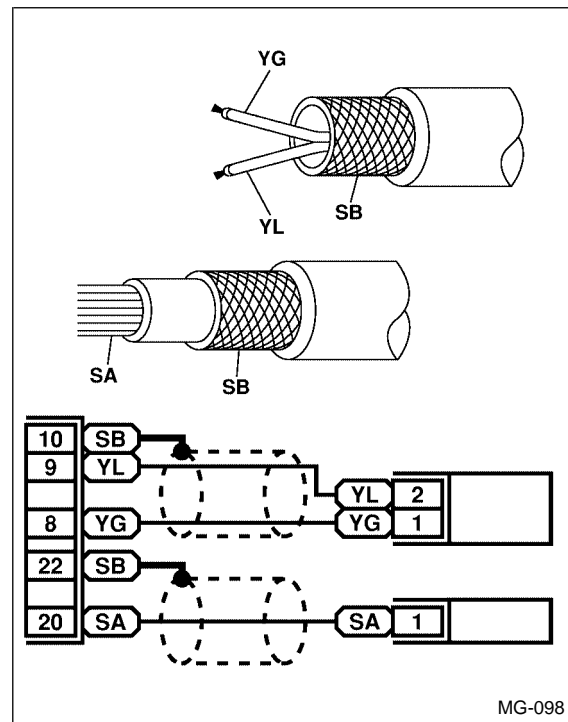

BASIC DIAGNOSTICS PROCEDURE

Wiring System

- The wire color code, which consists of two letters (or three letters including Br or Lg), indicates the standard color (base color of the wire covering) by its first letter and the stripe marking by its second letter.

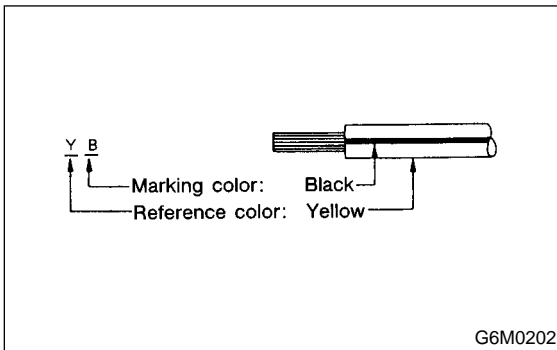

- The table lists the nominal sectional areas and allowable currents of the wires.

CAUTION:

When replacing or repairing a wire, be sure to use the same size and type of the wire which was originally used.

NOTE:

- The allowable current in the table indicates the tolerable amperage of each wire at an ambient temperature of 40°C (104°F).
- The allowable current changes with ambient temperature. Also, it changes if a bundle of more than two wires is used.

Nominal sectional area mm ²	No. of strands/ strand diameter	Outside diameter of finished wiring mm	Allowable current Amps/ 40°C (104°F)
0.3	7/0.26	1.8	7
0.5	7/0.32	2.2 (or 2.0)	12
0.75	30/0.18	2.6 (or 2.4)	16
0.85	11/0.32	2.4 (or 2.2)	16
1.25	16/0.32	2.7 (or 2.5)	21
2	26/0.32	3.1 (or 2.9)	28
3	41/0.32	3.8 (or 3.6)	38
5	65/0.32	4.6 (or 4.4)	51
8	50/0.45	5.5	67

- Each unit is directly grounded to the body or indirectly grounds through a harness ground terminal. Different symbols are used in the wiring diagram to identify the two grounding systems.

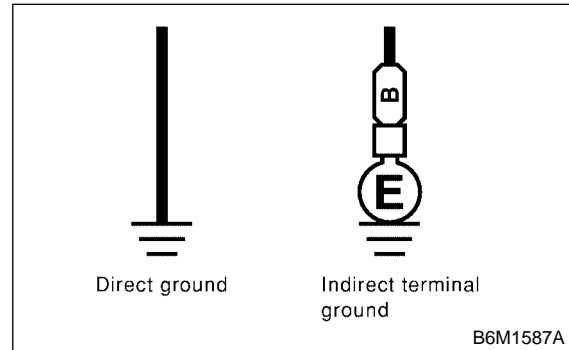

- The ground points shown in the wiring diagram refer to the following:

NOTE:

All wiring harnesses are provided with a ground point which should be securely connected.

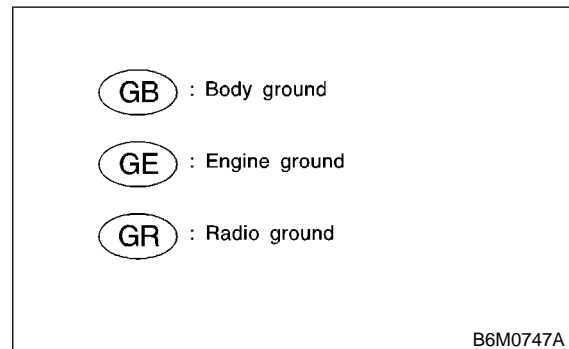

BASIC DIAGNOSTICS PROCEDURE

- Relays are classified as normally-open or normally-closed. The normally-closed relay has one or more contacts.
- The wiring diagram shows the relay mode when the energizing circuit is OFF.

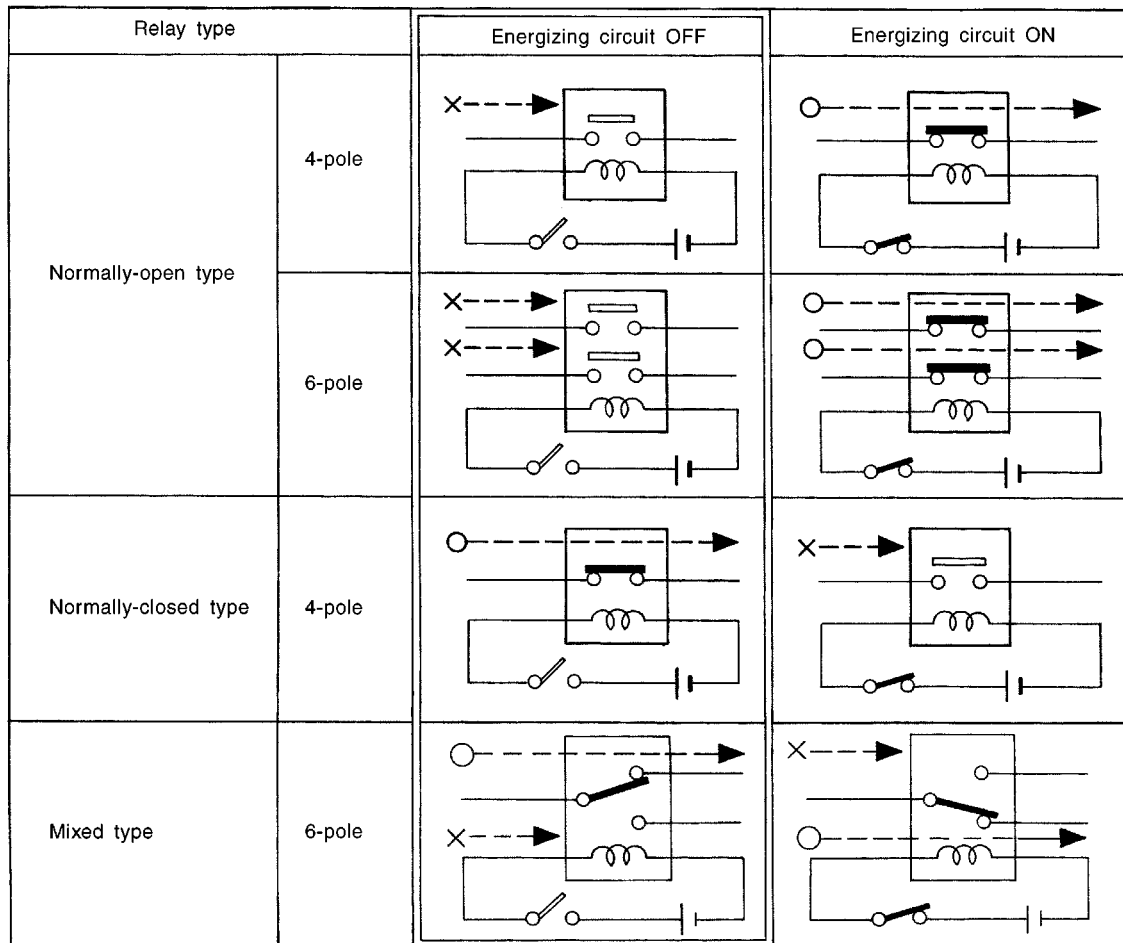

Key to symbols:

- —▶ : Current flows.
- × —▶ : Current does not flow.

BASIC DIAGNOSTICS PROCEDURE

Wiring System

- Each connector number shown in the wiring diagram corresponds to that in the wiring harness. The location of each connector in the actual vehicle is determined by reading the first character of the connector (for example, a "F" for F8, "i" for i16, etc.) and the type of wiring harness. The first character of each connector number refers to the area or system of the vehicle.

Symbol	Wiring harness and cord
F	Front wiring harness
B	Bulkhead wiring harness
E	Engine wiring harness
T	Transmission cord
D	Door cord LH & RH, Rear door cord LH & RH
i	Instrument panel wiring harness
R	Rear wiring harness, Fuel tank cord, Roof cord, Rear gate code

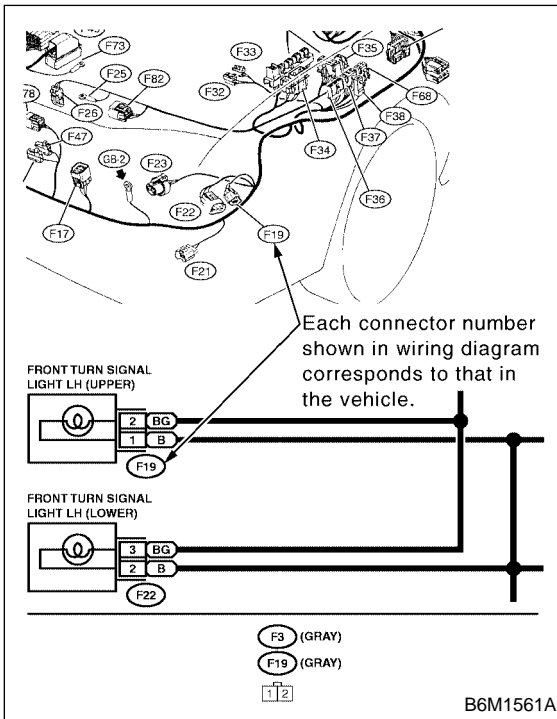

D: SYMBOLS IN WIRING DIAGRAMS S903627G53

A number of symbols are used in each wiring diagram to easily identify parts or circuits.

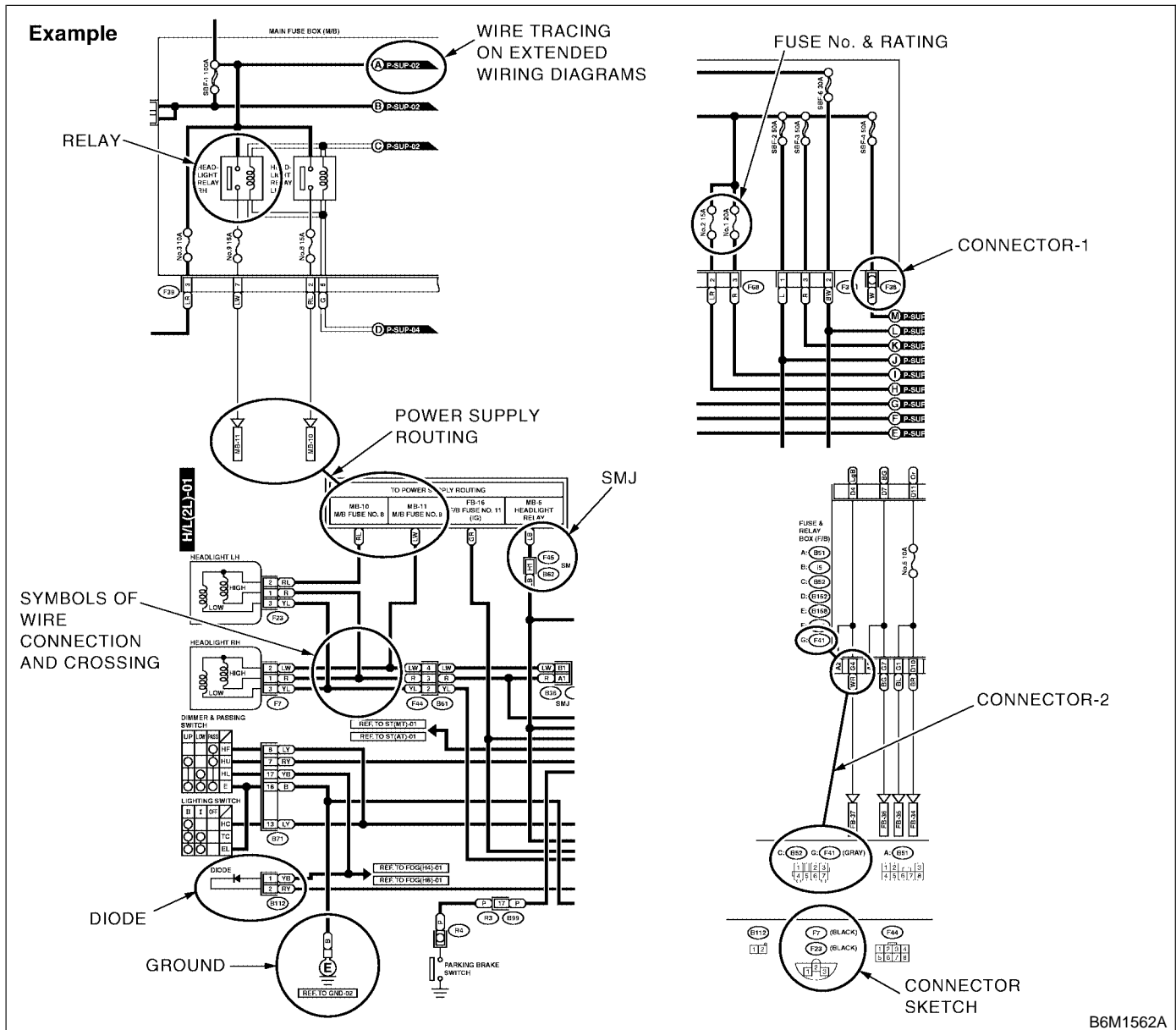

B6M1562A

1. RELAY S903627G5301

A symbol used to indicate a relay.

2. CONNECTOR-1 S903627G5302

The sketch of the connector indicates the one-pole types.

3. WIRING CONNECTION S903627G5303

Some wiring diagrams are indicated in foldouts for convenience. Wiring destinations are indicated where necessary by corresponding symbols (as when two pages are needed for clear indication).

4. FUSE No. & RATING G903627G5304

The "FUSE No. & RATING" corresponds with that used in the fuse box (main fuse box, fuse and joint box).

5. CONNECTOR-2 S903627G5305

- Each connector is indicated by a symbol.
- Each terminal number is indicated in the corresponding wiring diagram in an abbreviated form.
- For example, terminal number "C2" refers to No. 2 terminal of connector (C: F41) shown in the connector sketch.

BASIC DIAGNOSTICS PROCEDURE

Wiring System

6. CONNECTOR SKETCH S903627G5306

- Each connector sketch clearly identifies the shape and color of a connector as well as terminal locations. Non-colored connectors are indicated in natural color.
- When more than two types of connector number are indicated in a connector sketch, it means that the same type connectors are used.

7. GROUND S903627G5307

Each grounding point can be located easily by referring to the corresponding wiring harness.

8. DIODE S903627G5308

A symbol is used to indicate a diode.

9. WIRE TRACING ON EXTENDED WIRING DIAGRAMS S903627G5309

For a wiring diagram extending over at least two pages, a symbol (consisting of the same characters with arrows), facilitates wire tracing from one page to the next.

A \longleftrightarrow A, B \longleftrightarrow B

10. SYMBOLS OF WIRE CONNECTION AND CROSSING S903627G5310

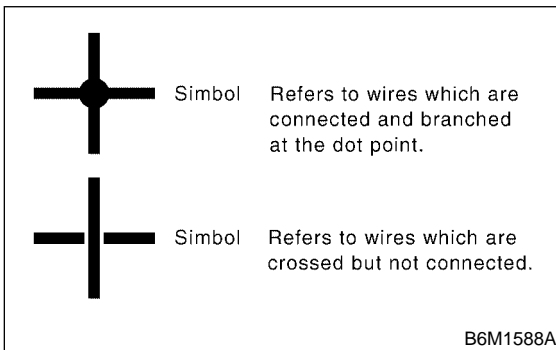

11. POWER SUPPLY ROUTING S903627G5311

A symbol is used to indicate the power supply in each wiring diagram.

“MB-5”, “MB-6”, etc., which are used as power-supply symbols throughout the text, correspond with those shown in the POWER SUPPLY ROUTING in the wiring diagram.

Accordingly, using the POWER SUPPLY ROUTING and wiring diagrams permits service personnel to understand the entire electrical arrangement of a system.

E: ABBREVIATION IN WIRING DIAGRAMS S903627G54

Abbr.	Full name
ABS	Antilock Brake System
ACC	Accessory
A/C	Air Conditioning
AD	Auto Down
AT	Automatic Transmission
AU	Auto Up
+B	Battery
DN	Down
E	Ground
F/B	Fuse & Joint Box
FL1.5	Fusible link 1.5 mm ²
IG	Ignition
Illumi.	Illumination
LH	Left Hand
Lo	Low
M	Motor
M/B	Main Fuse Box
MG	Magnet
Mi	Middle
OP	Optional Parts
PASS	Passing
RH	Right Hand
SBF	Slow Blow Fuse
ST	Starter
SW	Switch
UP	Up
WASH	Washer

2. Working Precautions S903706

A: PRECAUTIONS WHEN WORKING WITH THE PARTS MOUNTED ON THE VEHICLE S903706G38

- 1) When working under a vehicle which is jacked-up, always be sure to use safety stands.
- 2) The parking brake must always be applied during working. Also, in automatic transmission vehicles, keep the select lever set to the P (Parking) range.
- 3) Be sure the workshop is properly ventilated when running the engine. Further, be careful not to touch the belt or fan while the engine is operating.
- 4) Be careful not to touch hot metal parts, especially the radiator and exhaust system immediately after the engine has been shut off.

B: PRECAUTIONS IN TROUBLE DIAGNOSIS AND REPAIR OF ELECTRIC PARTS S903706G39

- 1) The battery cable must be disconnected from the battery's (-) terminal, and the ignition switch must be set to the OFF position, unless otherwise required by the diagnostics.
- 2) Securely fasten the wiring harness with clamps and slips so that the harness does not interfere with the body end parts or edges and bolts or screws.
- 3) When installing parts, be careful not to catch them on the wiring harness.
- 4) When disconnecting a connector, do not pull the wires, but pull while holding the connector body.

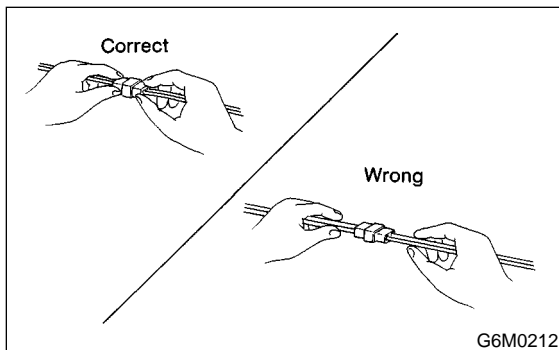

- 5) Some connectors are provided with a lock. One type of such a connector is disconnected by pushing the lock, and the other, by moving the lock up. In either type the lock shape must be identified before attempting to disconnect the connector. To connect, insert the connector until it snaps and confirm that it is tightly connected.

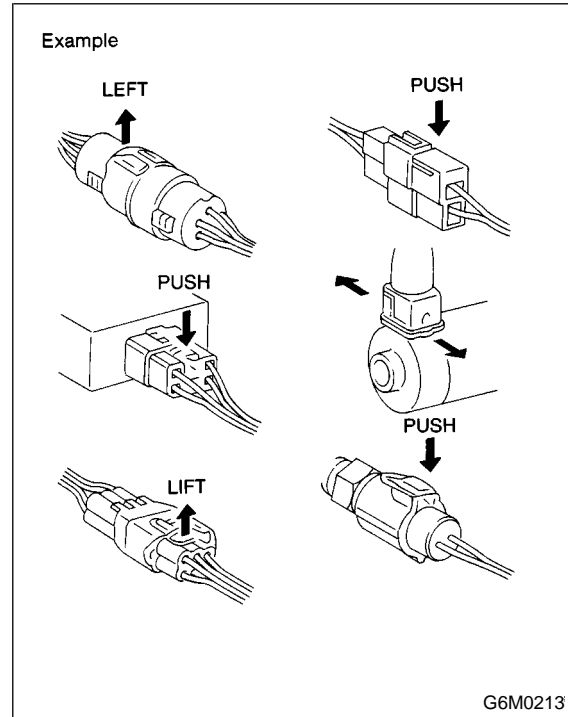

- 6) When checking continuity between connector terminals, or measuring voltage across the terminal and ground, always contact tester probe(s) on terminals from the wiring connection side. If the probe is too thick to gain access to the terminal, use "mini" test leads.

To check waterproof connectors (which are not accessible from the wiring side), contact test probes on the terminal side being careful not to bend or damage the terminals.

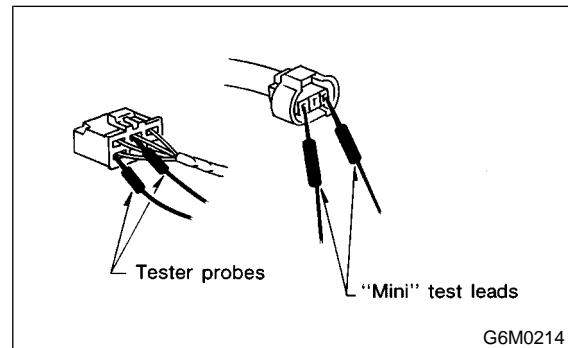

- 7) Sensors, relays, electrical unit, etc., are sensitive to strong impacts. Handle them with care so that they are not dropped or mishandled.

POWER SUPPLY ROUTING

Wiring System

3. Power Supply Routing S903465

A: SCHEMATIC S903465A21

1. LHD MODEL S903465A2101

P-SUP(L)-01

P-SUP(L)-01

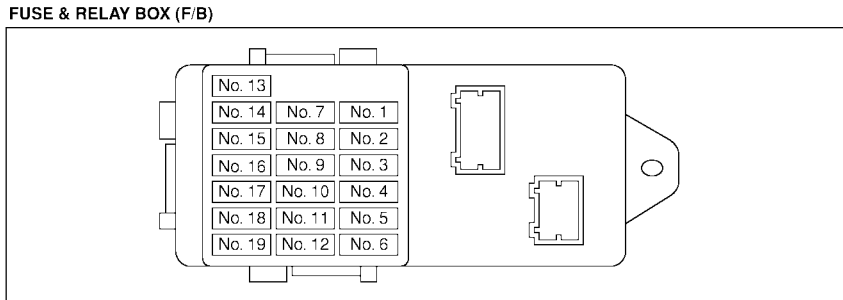
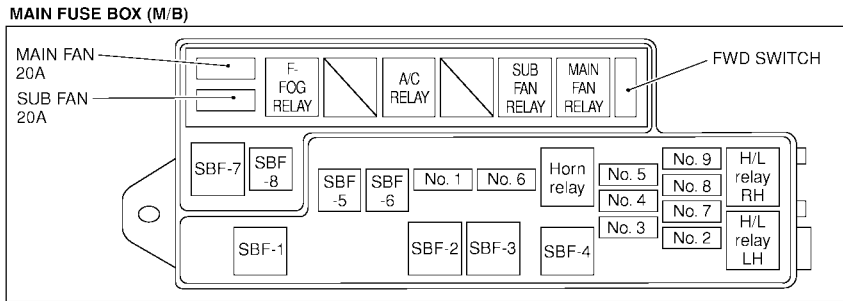

POWER SUPPLY ROUTING

Wiring System

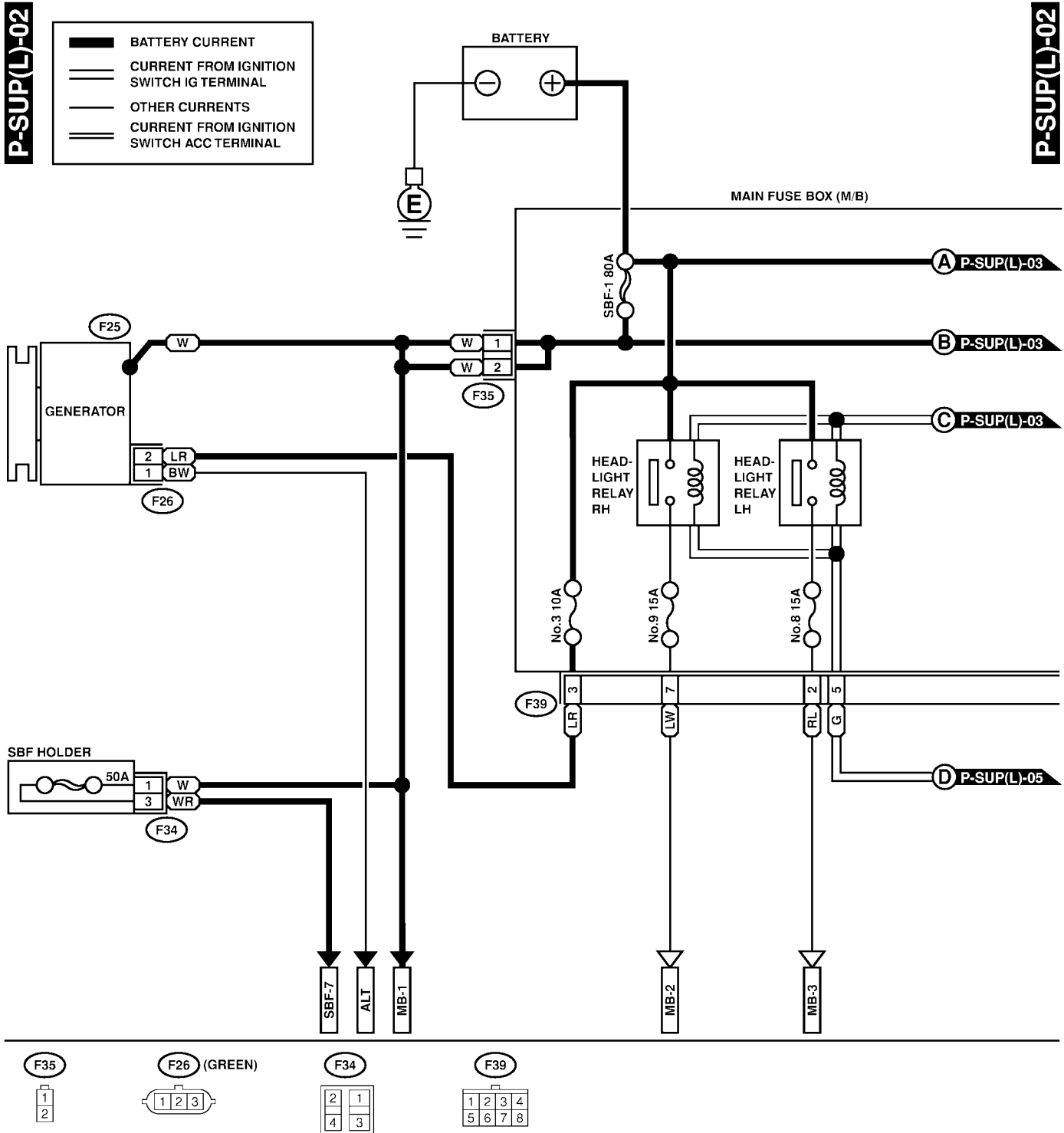

POWER SUPPLY ROUTING

Wiring System

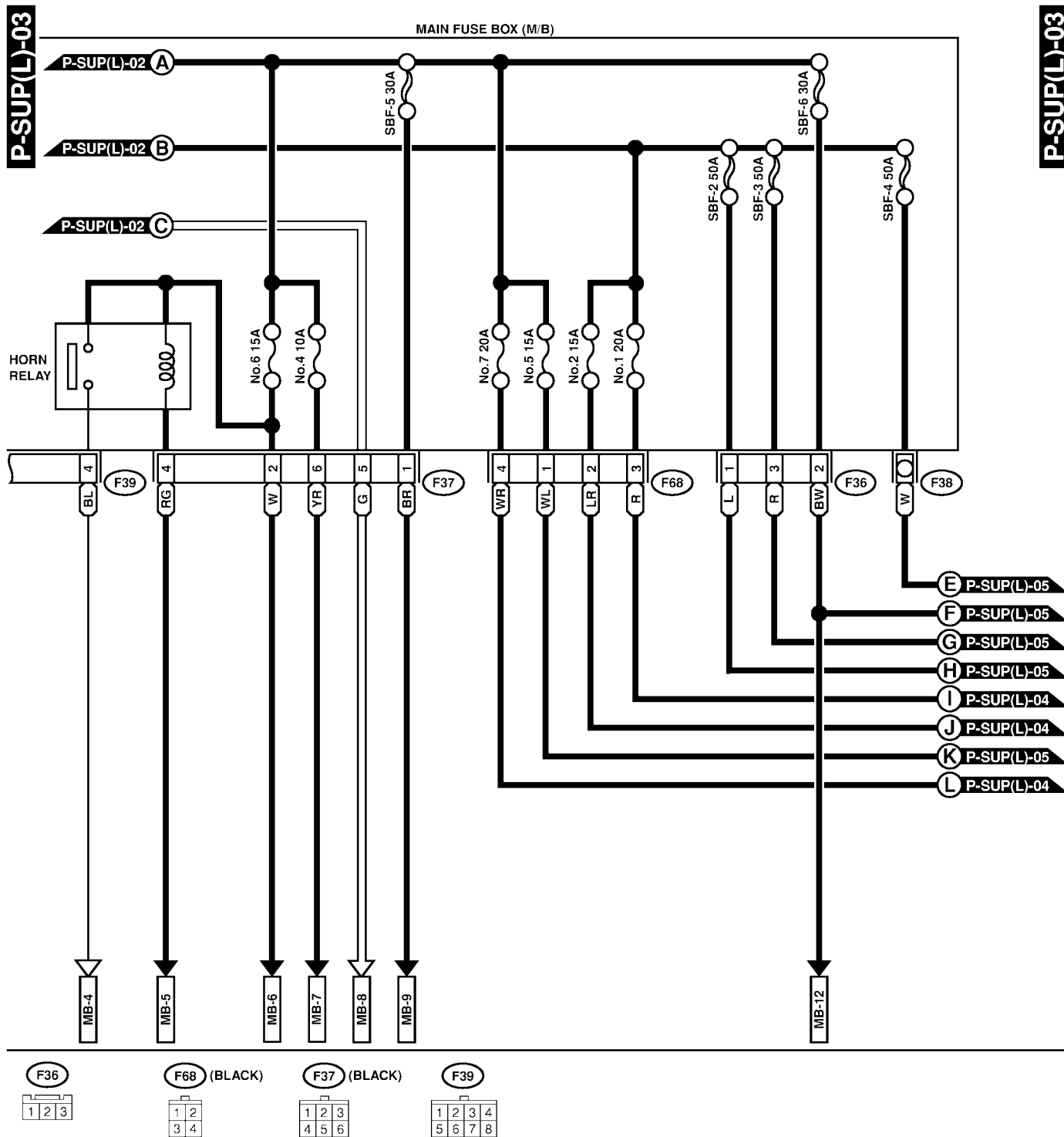

POWER SUPPLY ROUTING

Wiring System

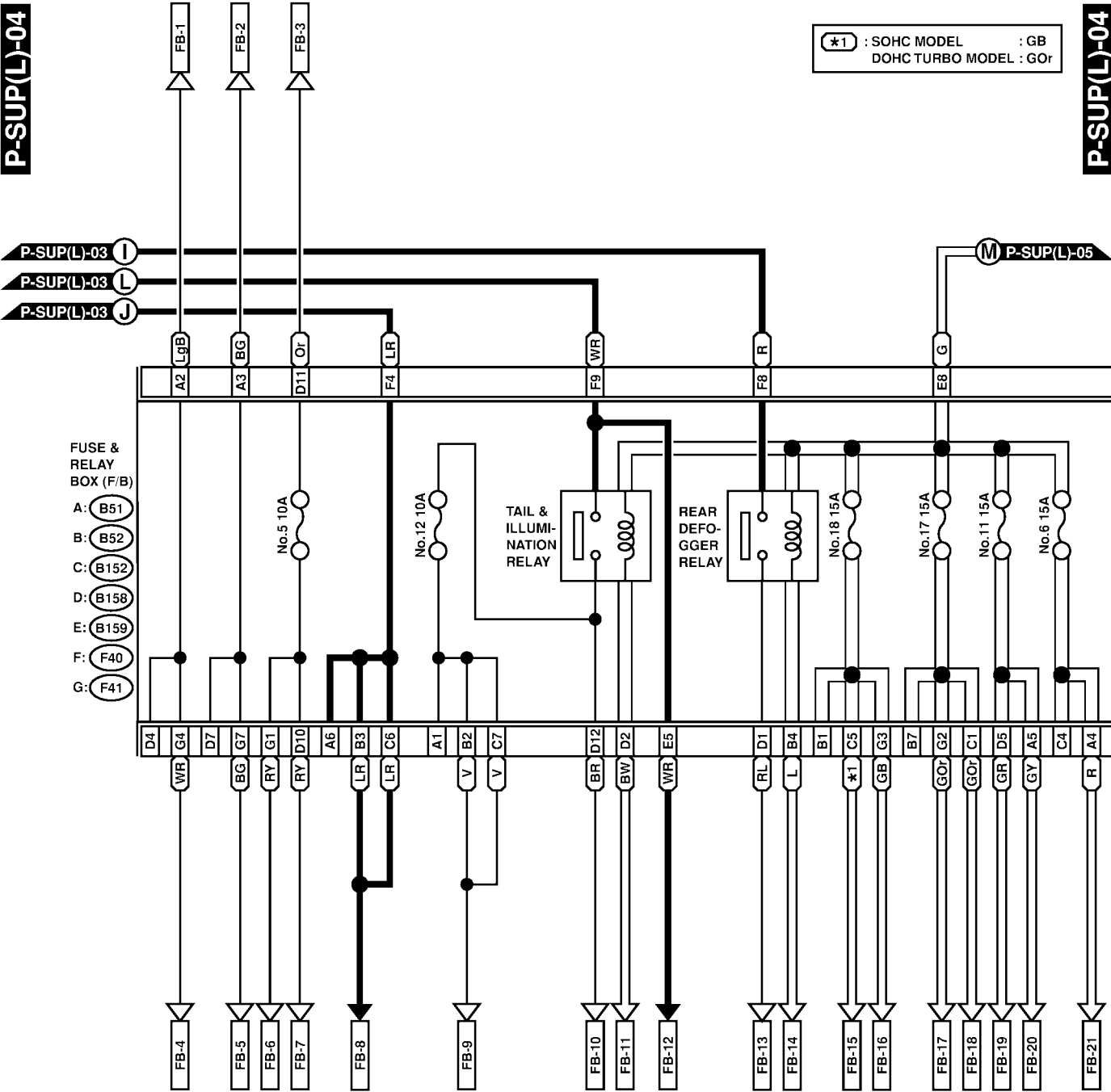

*1 : SOHC MODEL : GB
DOHC TURBO MODEL : GOr

P-SUP(L)-04

P-SUP(L)-04

- FUSE & RELAY BOX (F/B)
- A: (B51)
 - B: (B52)
 - C: (B152)
 - D: (B158)
 - E: (B159)
 - F: (F40)
 - G: (F41)

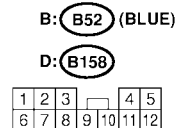
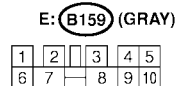
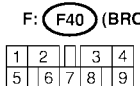
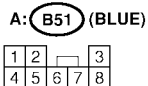
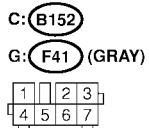

POWER SUPPLY ROUTING

Wiring System

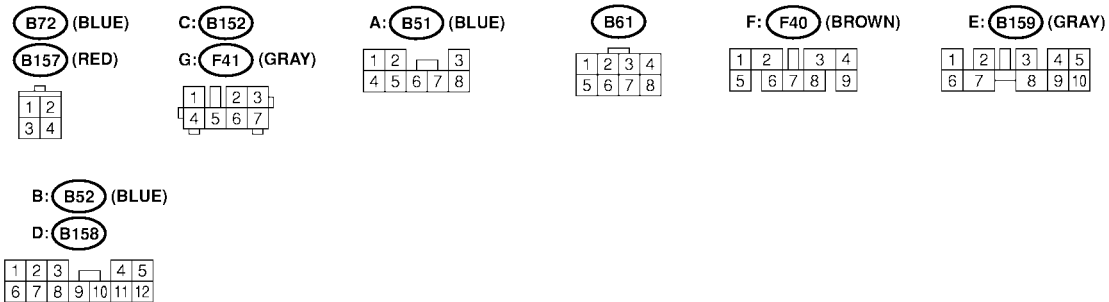
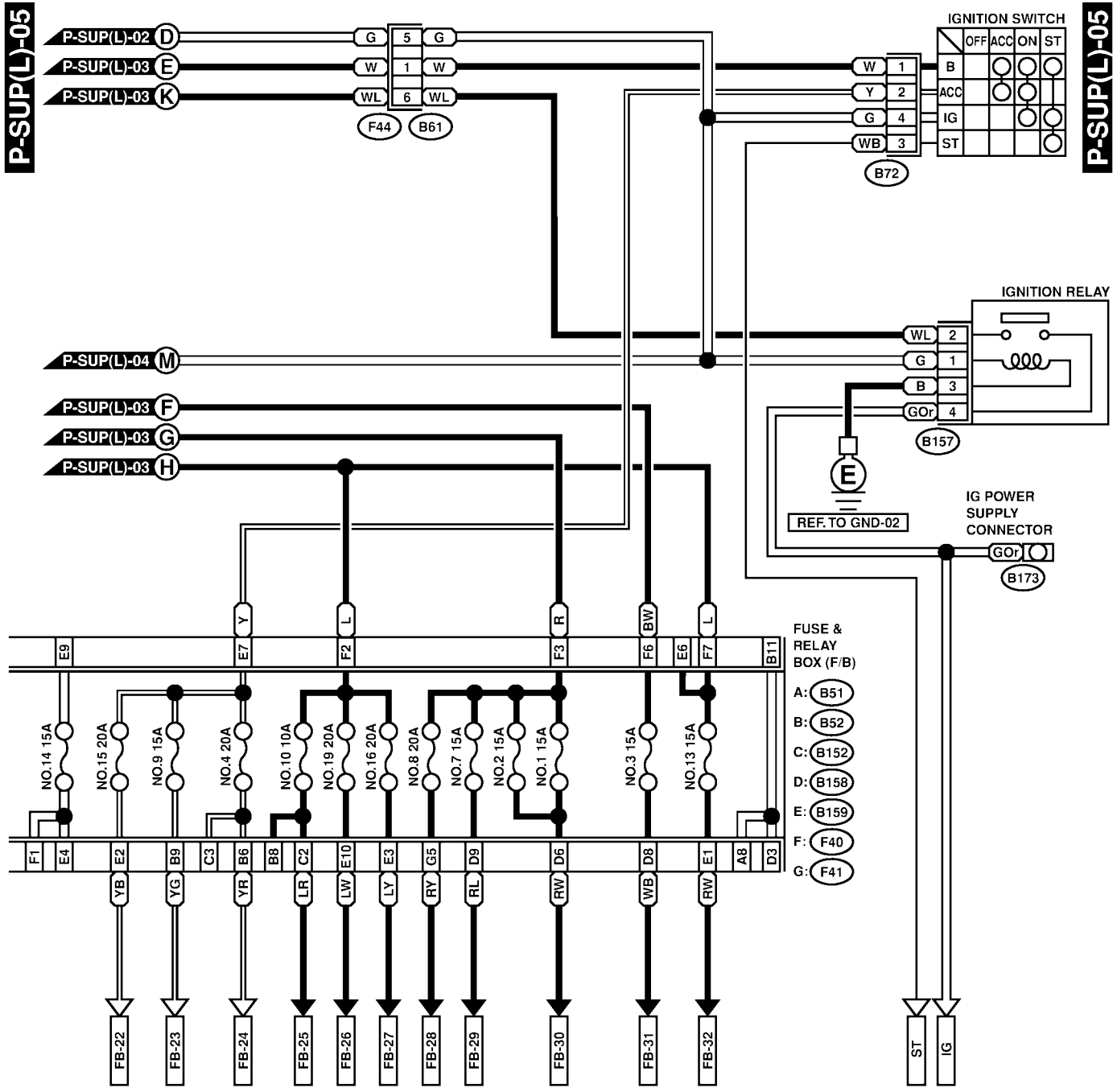

POWER SUPPLY ROUTING

Wiring System

No.	Load
MB-1	A/C relay holder
MB-2	Headlight RH Combination meter
MB-3	Headlight LH
MB-4	Horn
MB-5	Horn switch
MB-6	Hazard switch Key switch Keyless entry control module
MB-7	Transmission control module
MB-8	Diode (With rear fog light) Diode (lighting) Lighting switch
MB-9	Data link connector Engine control module Fuel pump relay Main relay Immobilizer control module
MB-12	Headlight washer module Power window circuit breaker
SBF-7	ABS control module
ALT-1	Combination meter
IG	Check connector Combination meter Hazard switch Headlight washer switch Mirror heater condenser Mirror heater LH Mirror heater RH Power window relay Seatbelt timer Speed warning module Vehicle speed sensor (MT)
ST	Engine control module (AT) Inhibitor switch (AT) Starter motor (AT)
FB-1	Combination meter Hazard switch Rear turn signal light RH Trailer connector Turn signal switch
FB-2	Combination meter Keyless entry control module Hazard switch Turn signal switch Rear turn signal light LH
FB-3	Parking switch
FB-4	Side turn signal light RH Front turn signal light RH
FB-5	Side turn signal light LH Front turn signal light LH
FB-6	Front clearance light LH Front clearance light RH Headlight leveler LH Headlight leveler RH
FB-7	License plate light Trailer connector

No.	Load
FB-8	Combination meter Radio Room light Keyless entry control module Key illumination light Clock Luggage room light Spot light
FB-9	Rear fog light relay Headlight leveling switch Illumination light Illumination control module Front fog light relay Front fog light switch
FB-10	Parking switch
FB-11	Lighting switch
FB-12	Parking switch
FB-13	Rear defogger switch Rear defogger Mirror heater relay
FB-14	Rear defogger
FB-15	Wiper deicer Wiper deicer time Back-up light switch (MT) Inhibitor switch (AT)
FB-16	ABS control module A/C relay holder
FB-17	Air conditioner relay A/C relay holder
FB-18	Mode control panel Blower motor relay Pressure switch Rear defogger switch
FB-19	Fuel pump relay Engine control module Ignition coil and ignitor Transmission control module Immobilizer control module
FB-20	Airbag control module
FB-21	Airbag control module
FB-22	Front washer motor Front wiper motor Front wiper switch Rear wiper motor Rear wiper intermittent module
FB-23	Noise killer Radio Clock
FB-24	Remote rearview mirror switch Seat heater/rear accessory power supply relay Front accessory power supply socket
FB-25	Rear fog light relay
FB-26	Seat heater/rear accessory power supply relay
FB-27	Stop light Stop light switch

POWER SUPPLY ROUTING

Wiring System

No.	Load
FB-28	ABS control module
FB-29	Front fog light relay
FB-30	Blower motor relay
FB-31	Keyless entry control module
FB-32	Wiper deicer relay

2. RHD MODEL S903465A2102

P-SUP(R)-01

P-SUP(R)-01

MAIN FUSE BOX (M/B)

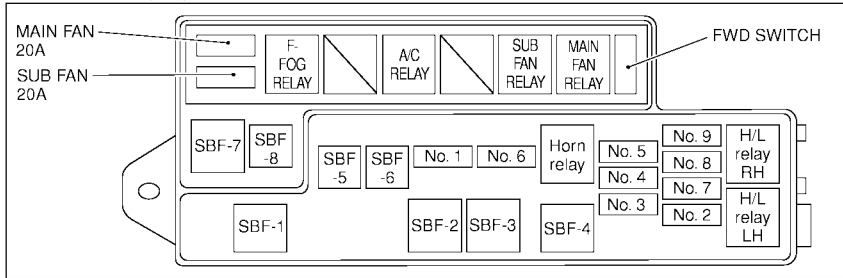

FUSE & RELAY BOX (F/B)

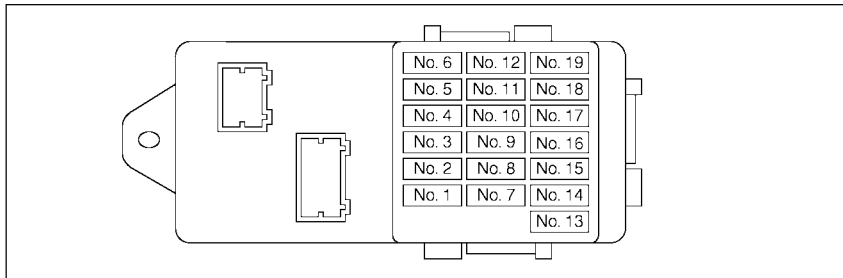

POWER SUPPLY ROUTING

Wiring System

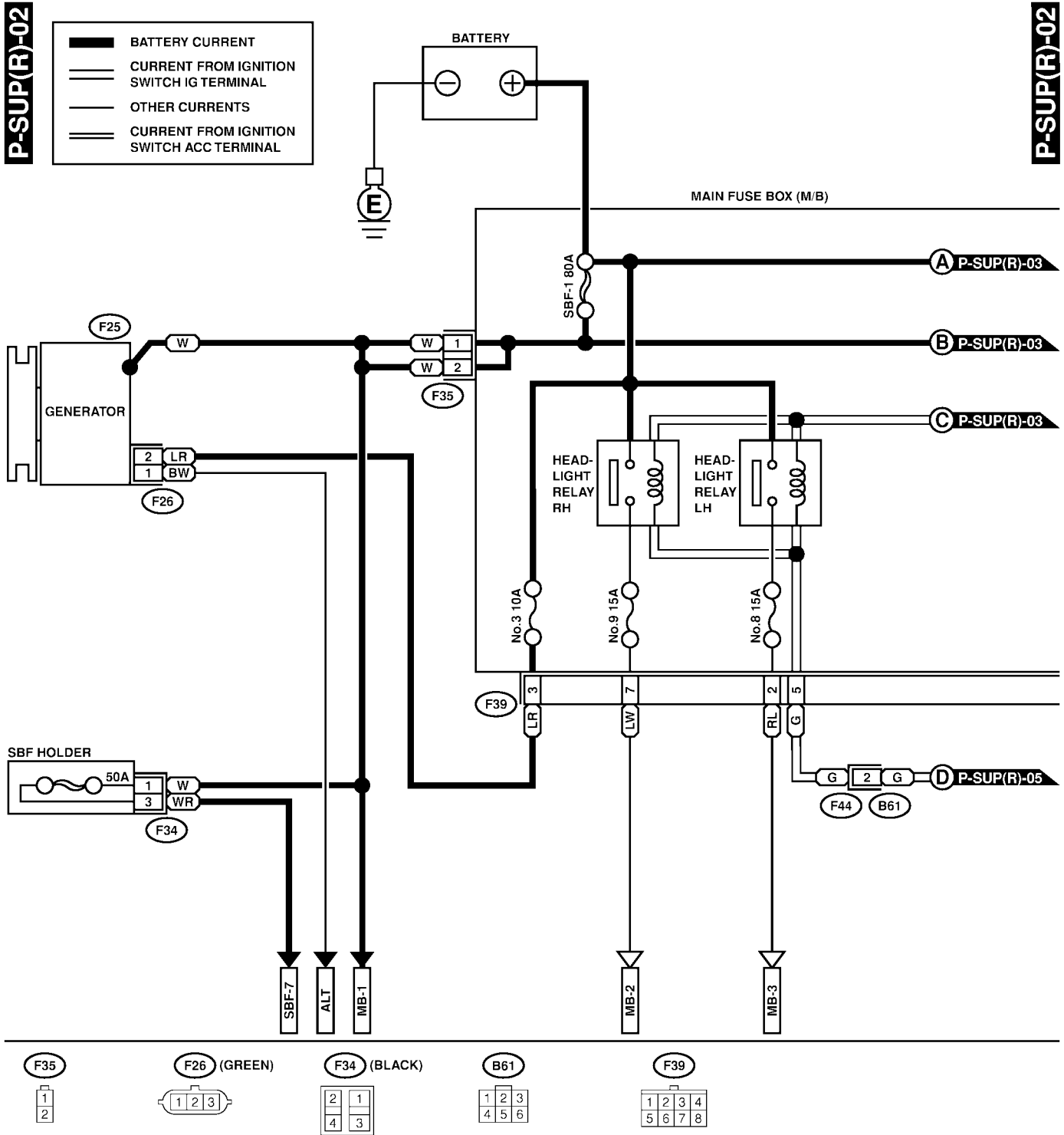

SR01-20B

POWER SUPPLY ROUTING

Wiring System

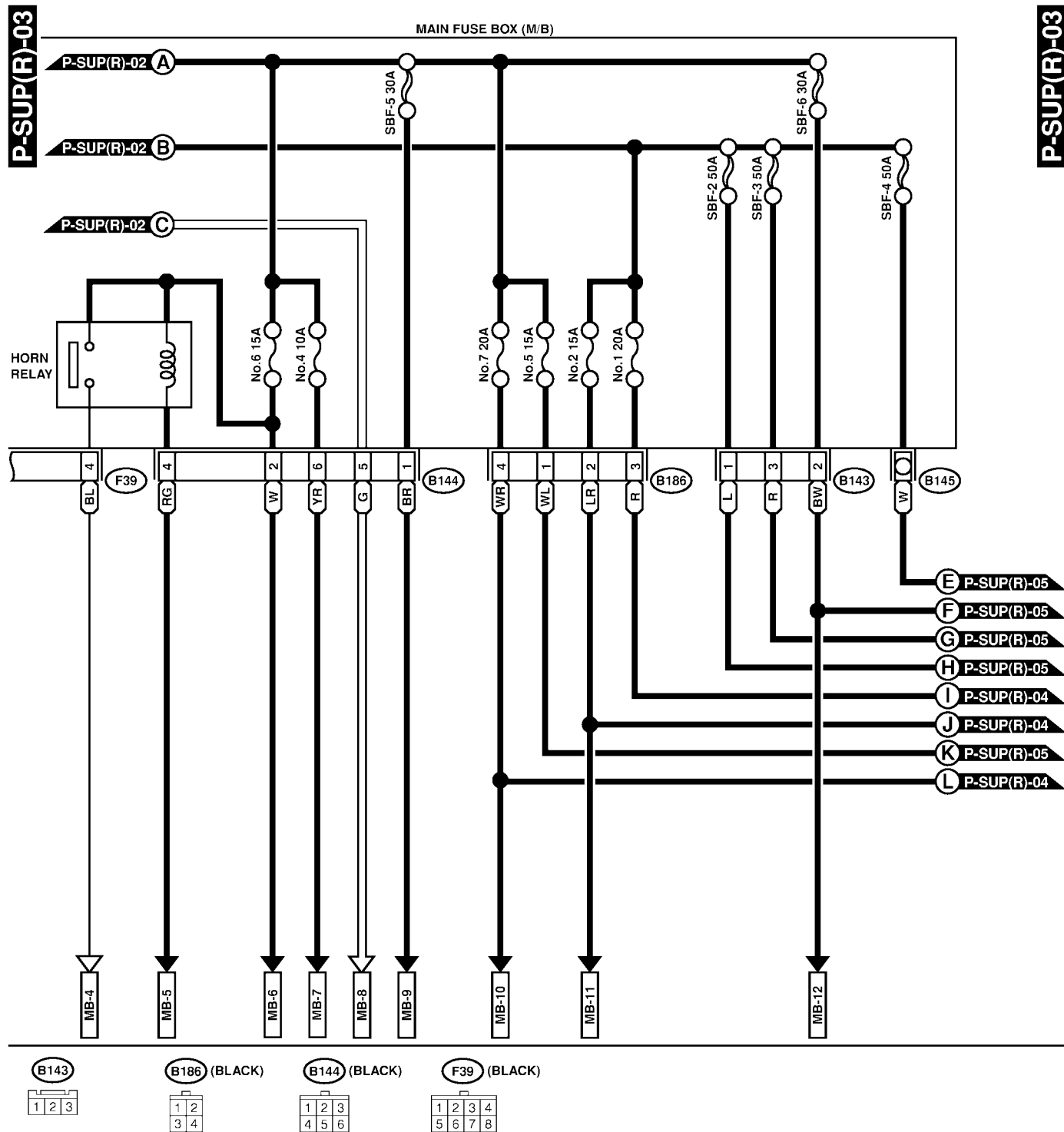

POWER SUPPLY ROUTING

Wiring System

*1 : SOHC MODEL : GB
DOHC TURBO MODEL : GOr

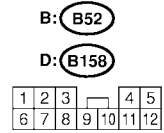
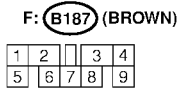
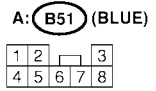
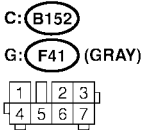
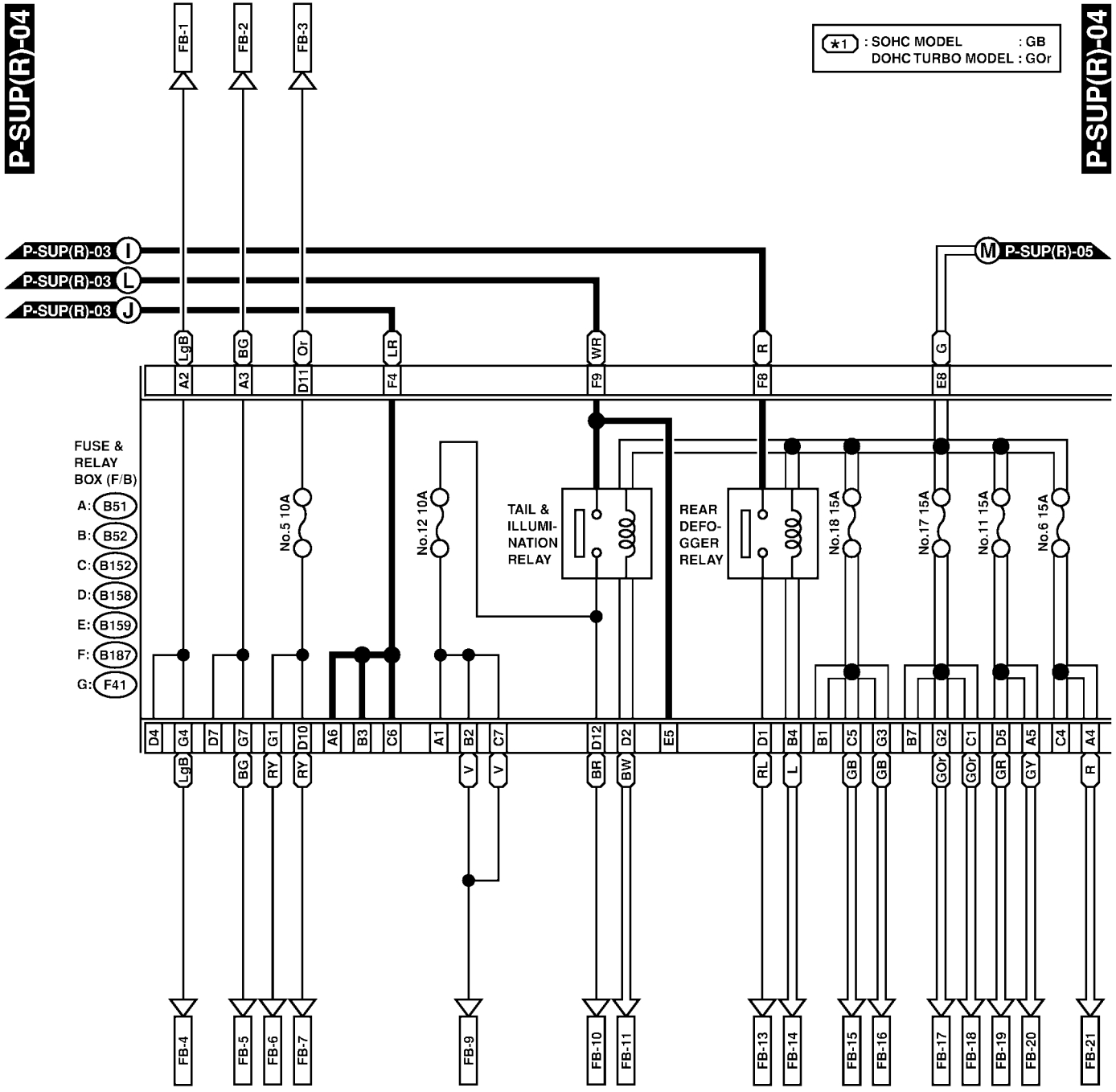

POWER SUPPLY ROUTING

Wiring System

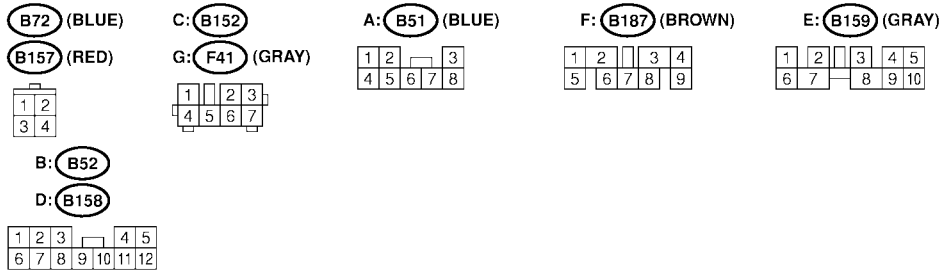
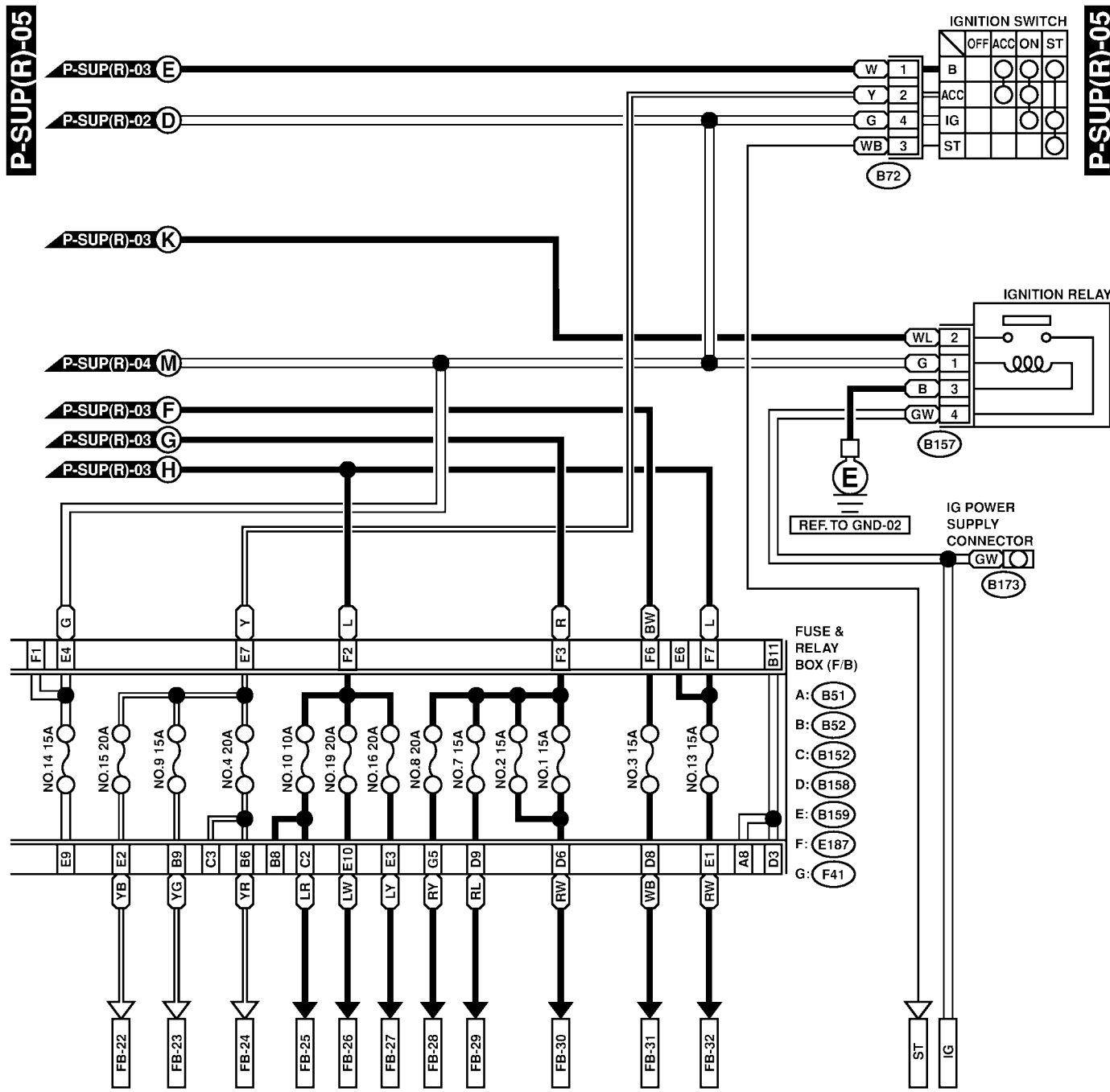

POWER SUPPLY ROUTING

Wiring System

No.	Load
MB-1	A/C relay holder
MB-2	Headlight RH Combination meter
MB-3	Headlight LH
MB-4	Horn
MB-5	Horn switch
MB-6	Hazard switch Key switch Keyless entry control module
MB-7	Transmission control module
MB-8	Diode (With rear fog light) Diode (lighting) Lighting switch
MB-9	Check connector Data link connector Engine control module Fuel pump relay Immobilizer control module Main relay
MB-10	Parking switch
MB-11	Combination meter Radio Room light Keyless entry control module Key illumination light Clock Luggage room light Spot light
MB-12	Headlight washer module Power window circuit breaker
SBF-7	ABS control module
ALT-1	Combination meter
IG	Check connector Combination meter Hazard switch Headlight washer switch Mirror heater condenser Mirror heater LH Mirror heater RH Power window relay Seatbelt timer Speed warning module Vehicle speed sensor (MT)
ST	Engine control module (AT) Inhibitor switch (AT) Starter motor (AT)
FB-1	Combination meter Trailer connector Rear turn signal light RH Hazard switch Turn signal switch Keyless entry control module

No.	Load
FB-2	Combination meter Keyless entry control module Hazard switch Turn signal switch Trailer connector Side turn signal light LH Rear turn signal light LH Front turn signal light RH
FB-3	Parking switch
FB-4	Side turn signal light RH Front turn signal light RH
FB-5	Front turn signal light LH
FB-6	Front clearance light LH Front clearance light RH Headlight leveler LH Headlight leveler RH
FB-7	License plate light Trailer connector
FB-9	Rear fog light relay Headlight leveling switch Illumination light Illumination control module Front fog light relay Front fog light switch
FB-10	Parking switch
FB-11	Lighting switch
FB-13	Rear defogger switch Rear defogger Mirror heater relay
FB-14	Rear defogger
FB-15	Back-up light switch (MT) Inhibitor switch (AT) Wiper deicer Wiper deicer timer
FB-16	ABS control module A/C relay holder
FB-17	Air conditioner relay A/C relay holder Power window relay
FB-18	Mode control panel Blower motor relay Pressure switch Rear defogger switch
FB-19	Fuel pump relay Engine control module Ignition coil and ignitor Transmission control module Immobilizer control module
FB-20	Airbag control module
FB-21	Airbag control module
FB-22	Front washer motor Front wiper motor Front wiper switch Rear wiper motor Rear wiper intermittent module

POWER SUPPLY ROUTING

Wiring System

No.	Load
FB-23	Noise killer Radio Clock
FB-24	Remote rearview mirror switch Seat heater/rear accessory power supply relay Front accessory power supply socket
FB-25	Rear fog light relay
FB-26	Seat heater/rear accessory power supply relay
FB-27	Stop light Stop light switch
FB-28	ABS control module
FB-29	Front fog light relay
FB-30	Blower motor relay
FB-31	Keyless entry control module
FB-32	Wiper deicer relay

GROUND DISTRIBUTION

Wiring System

4. Ground Distribution

S903472

A: SCHEMATIC

S903472A21

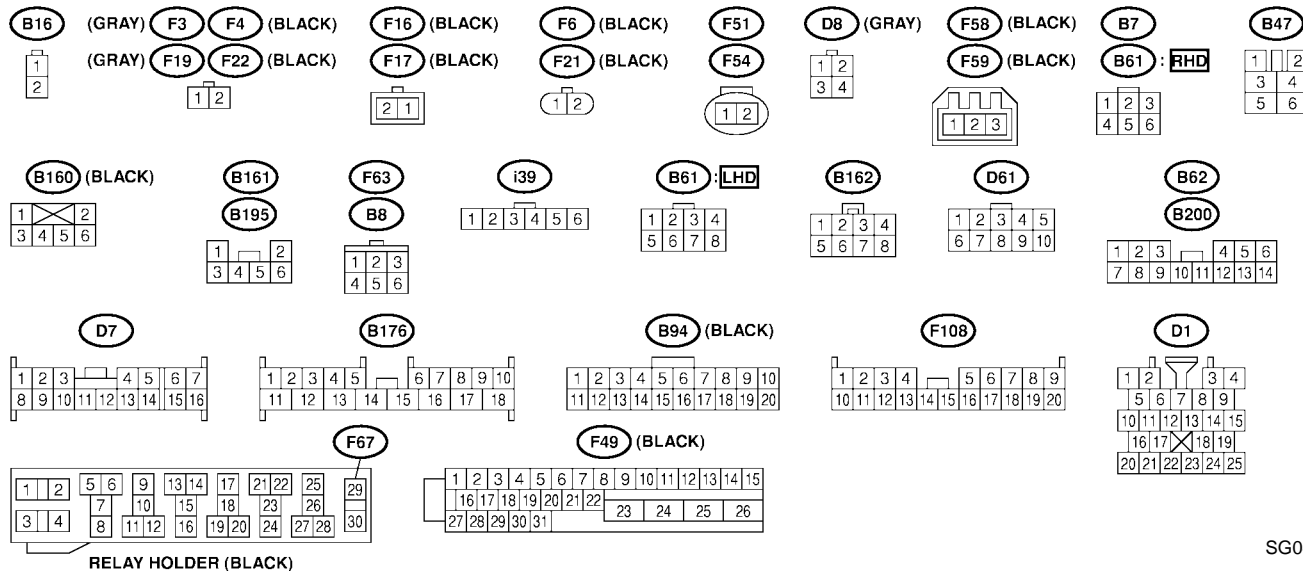
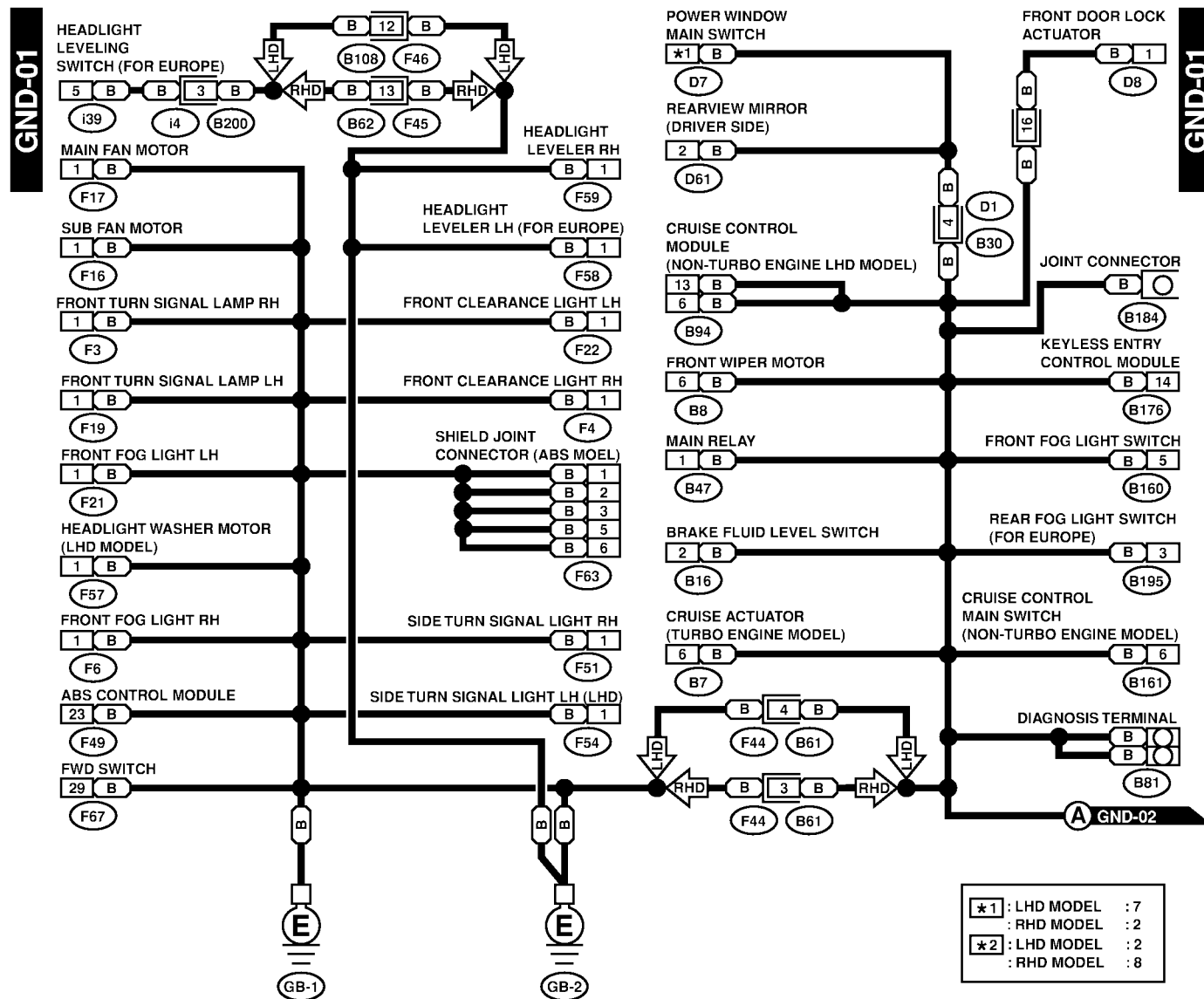

SG04-20A

GROUND DISTRIBUTION

Wiring System

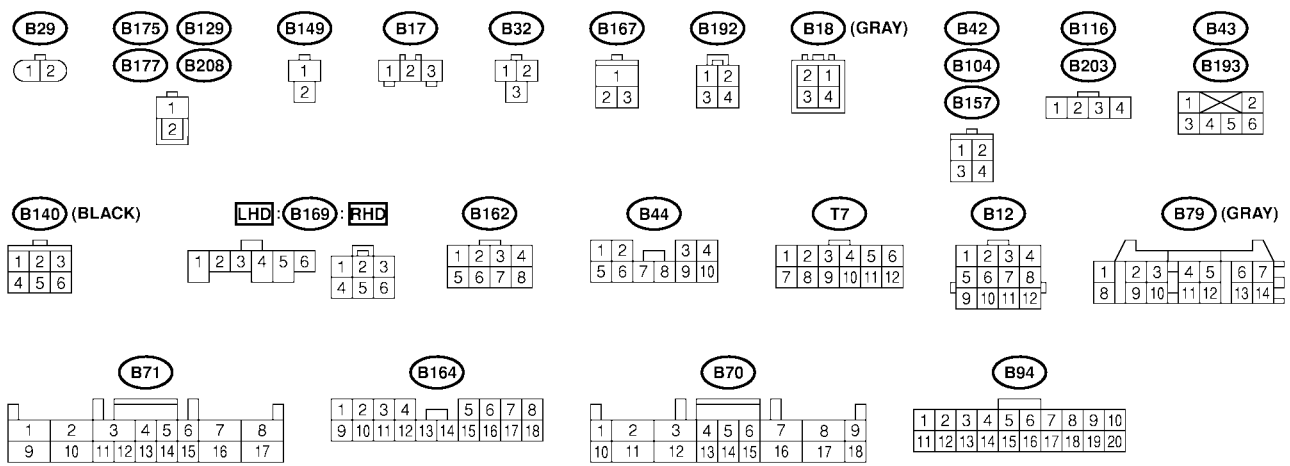
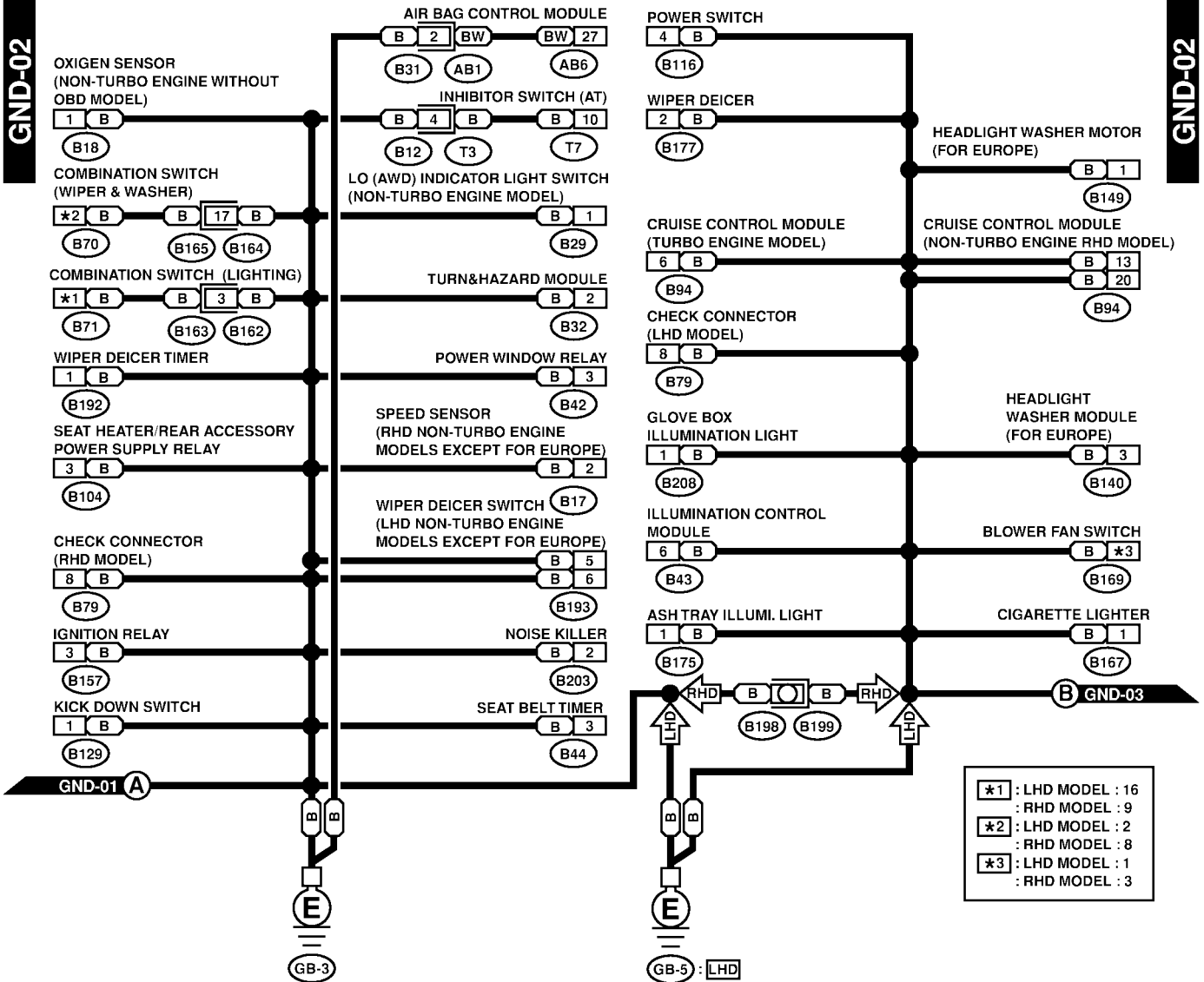

GROUND DISTRIBUTION

Wiring System

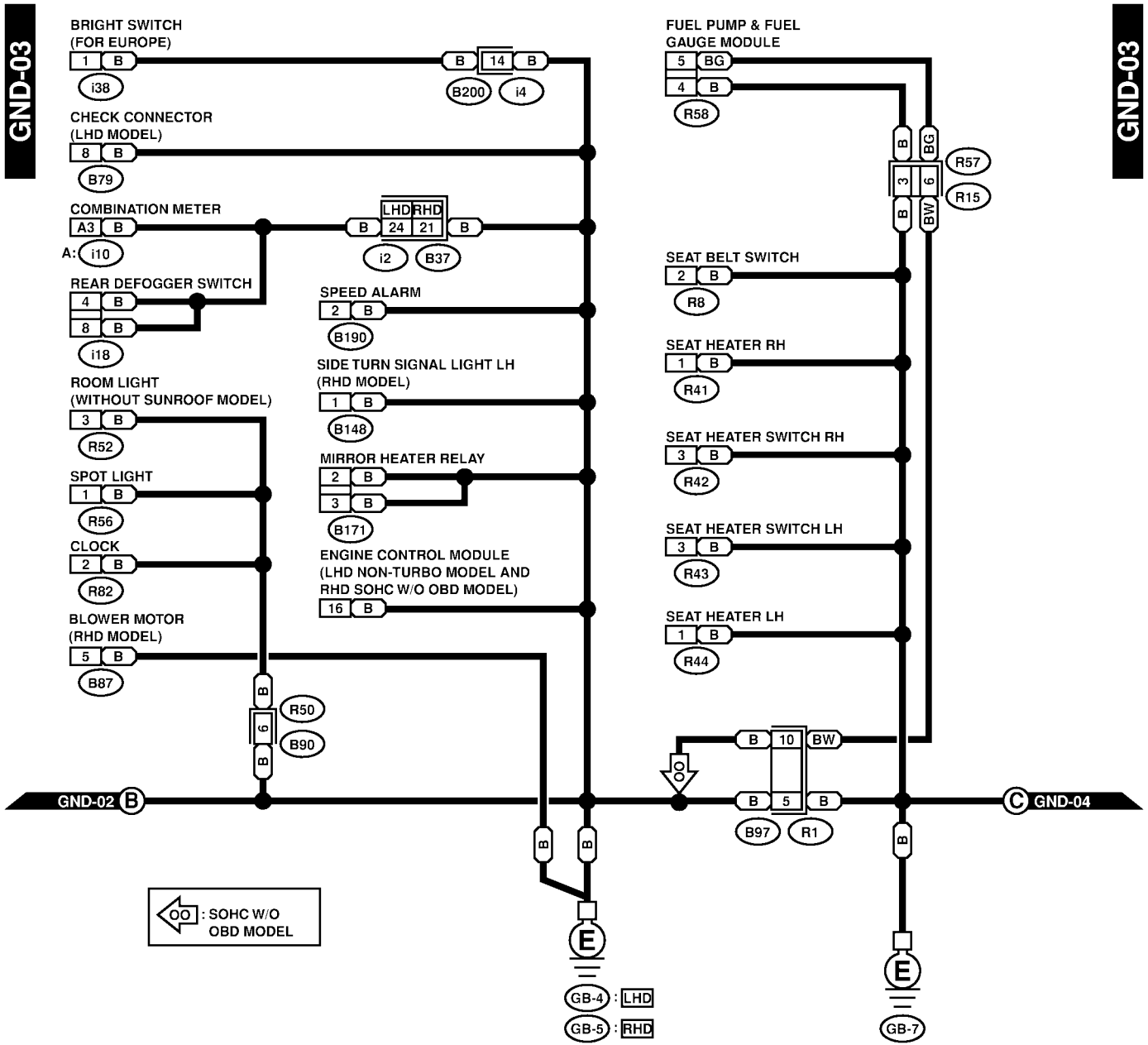

GND-03

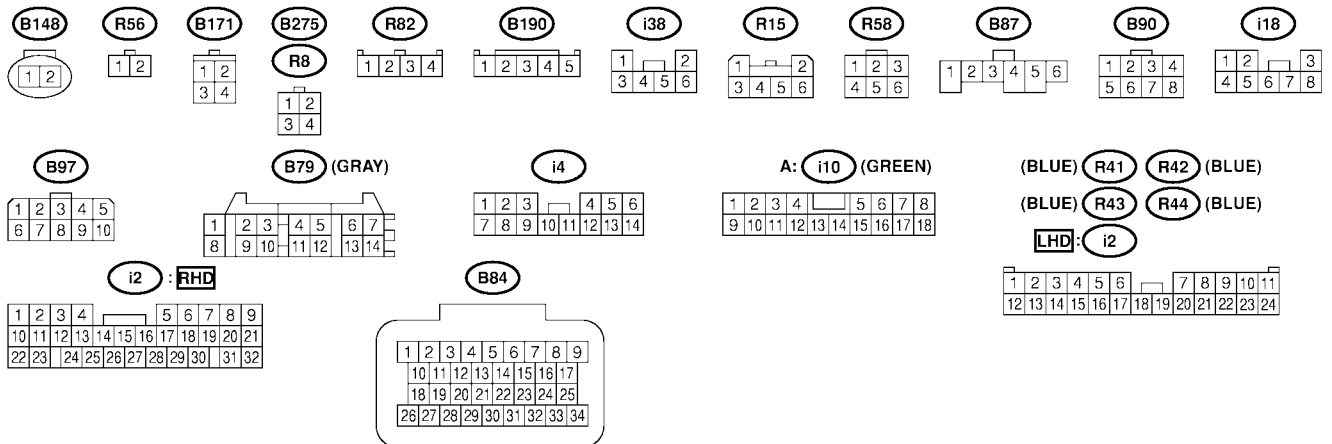

GROUND DISTRIBUTION

Wiring System

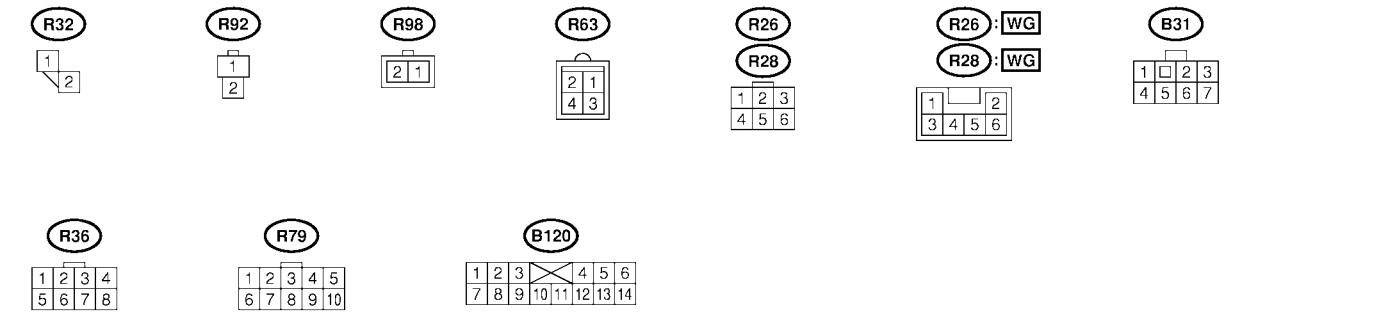
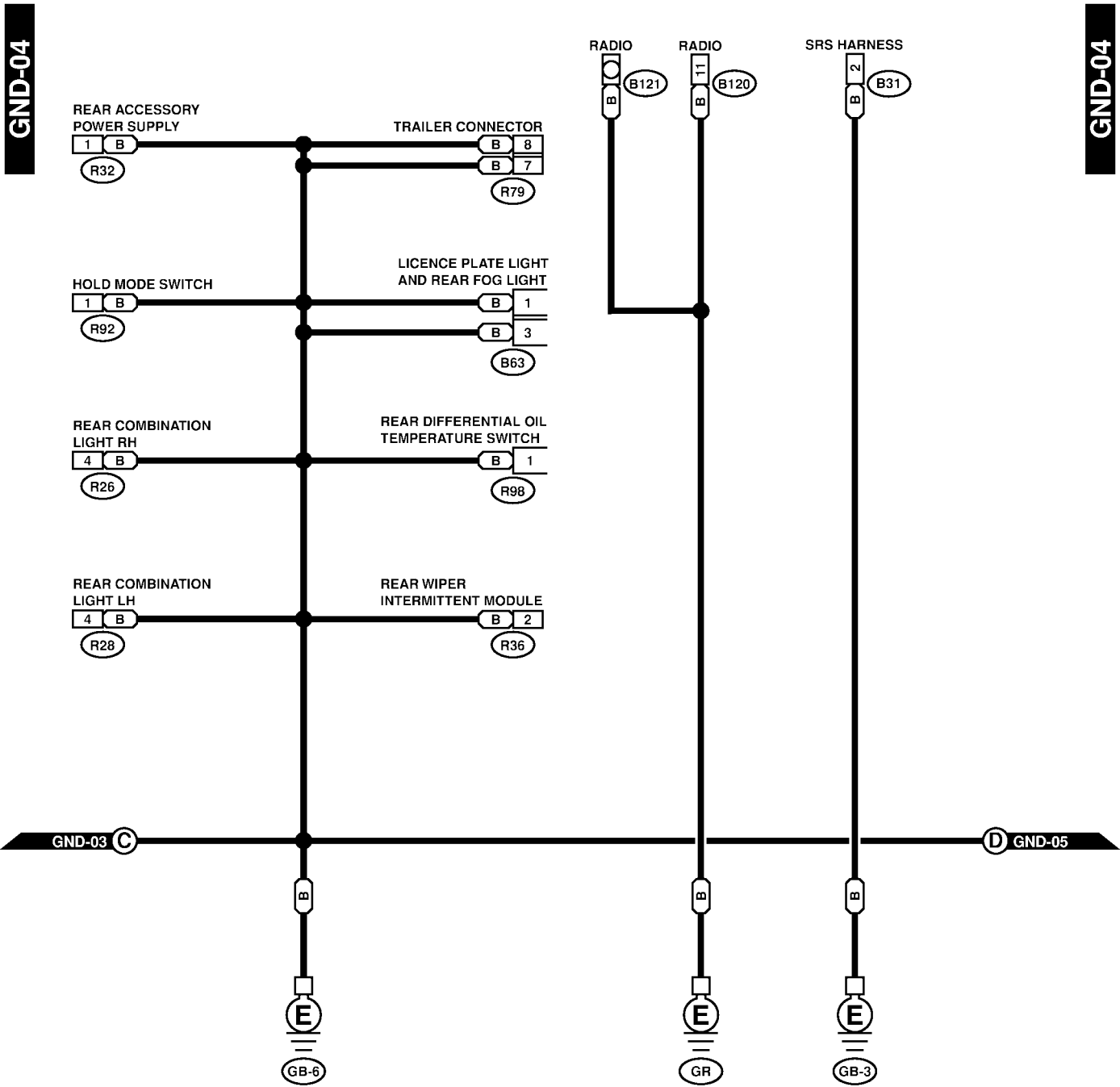

GROUND DISTRIBUTION

Wiring System

GND-05

GND-05

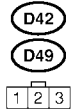
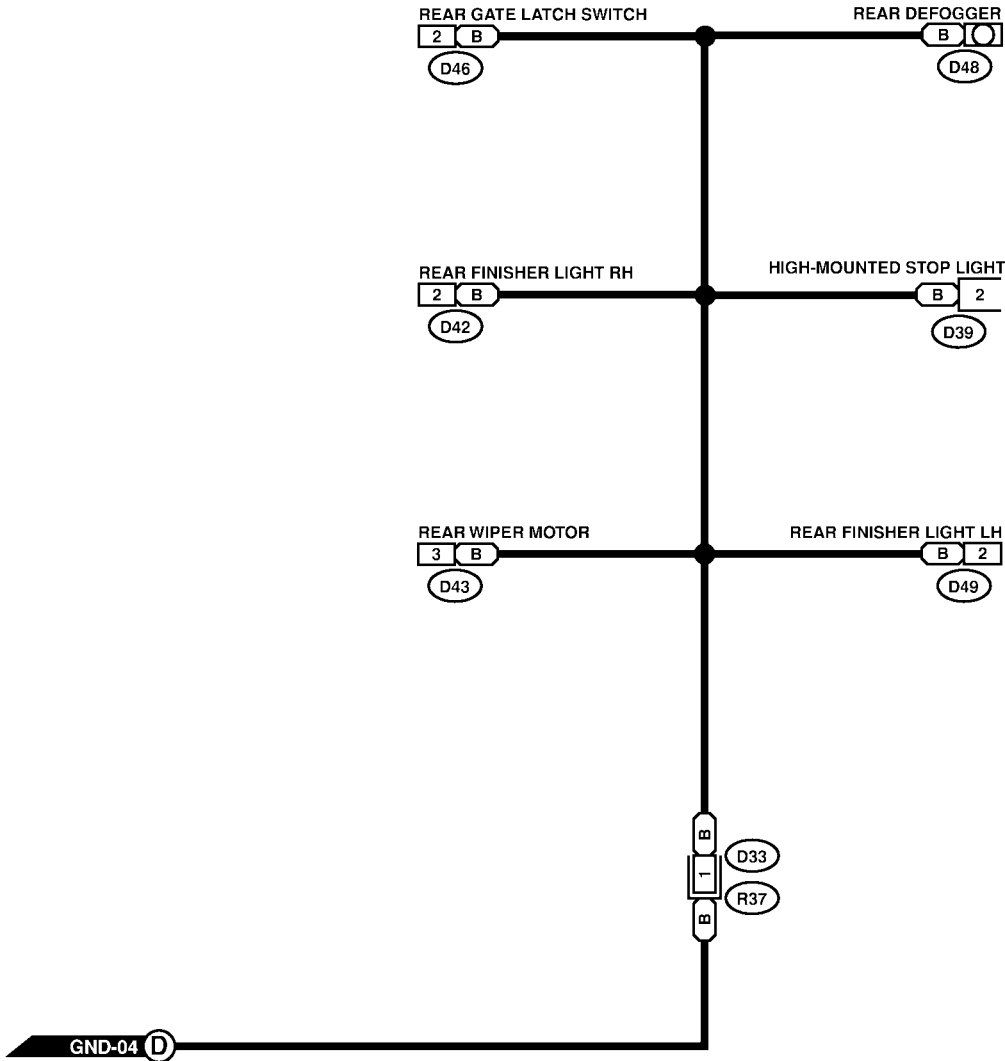

GROUND DISTRIBUTION

Wiring System

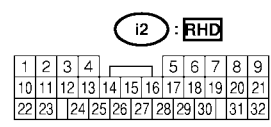
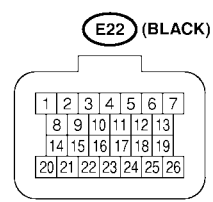
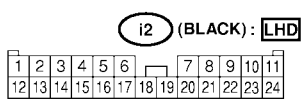
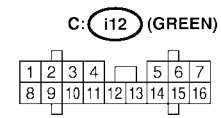
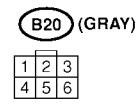
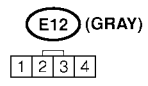
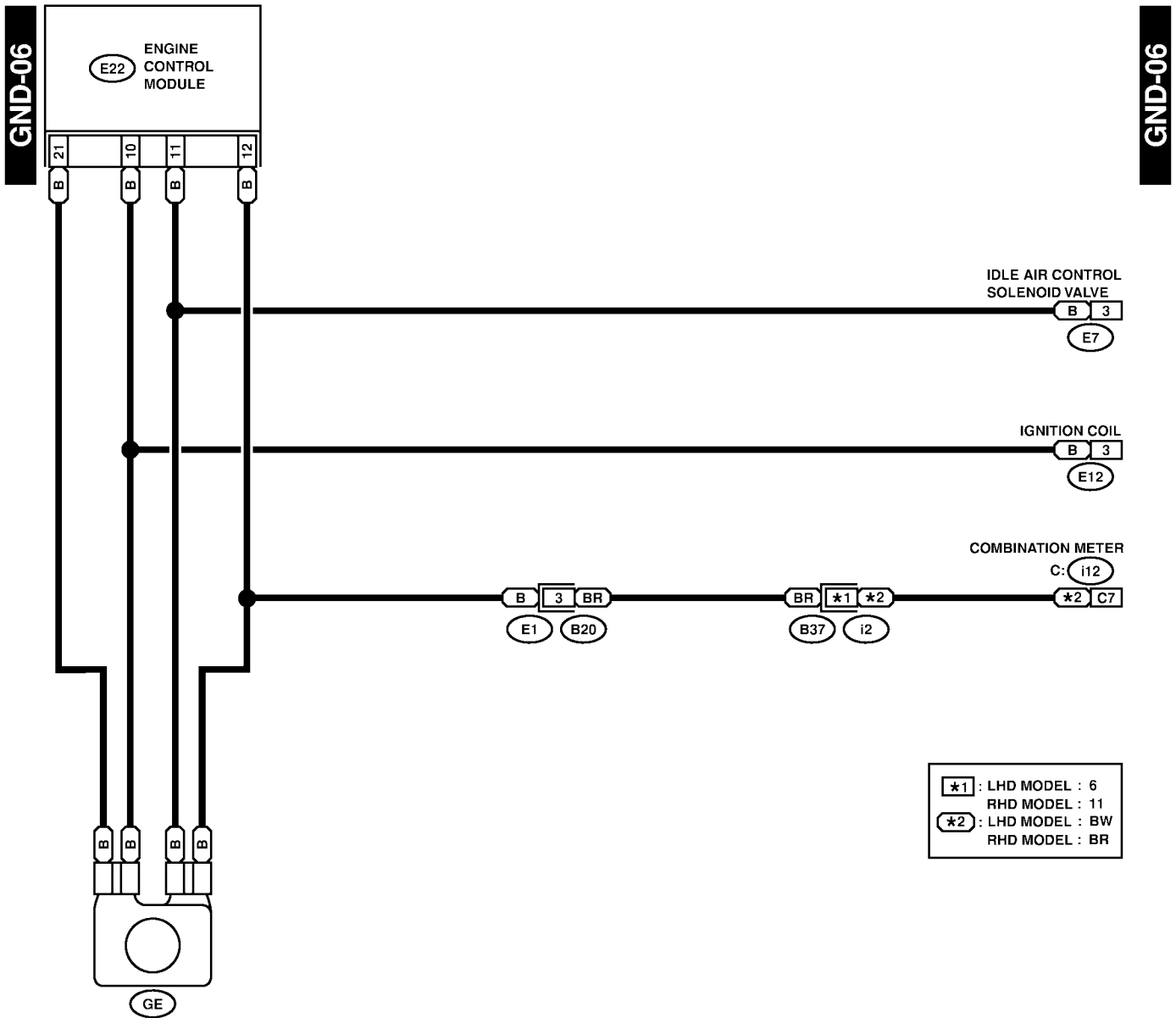

GROUND DISTRIBUTION

Wiring System

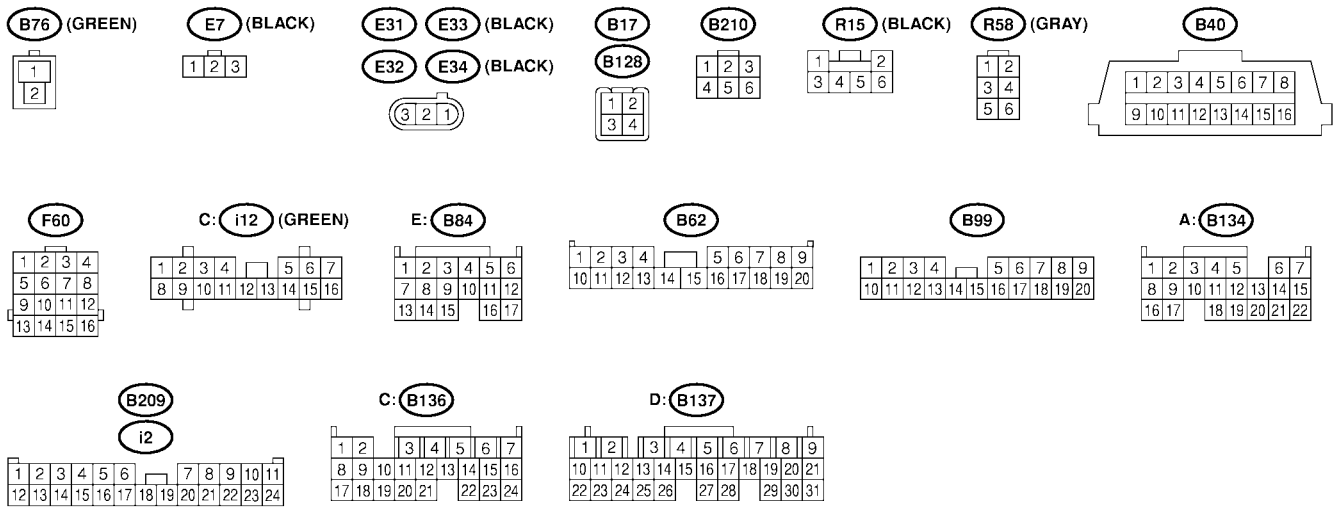
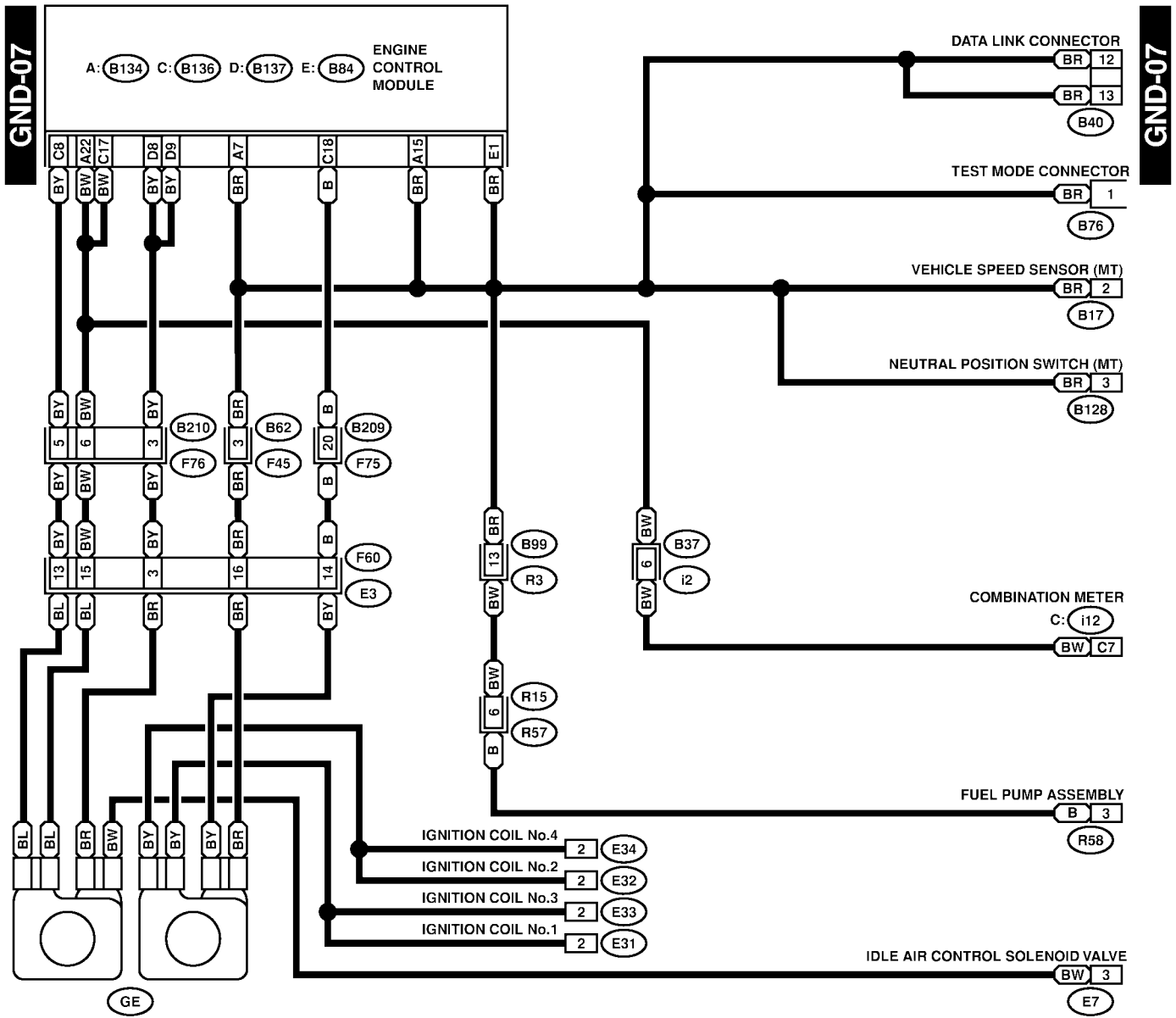

GROUND DISTRIBUTION

Wiring System

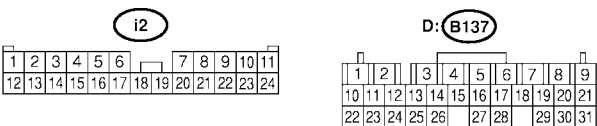
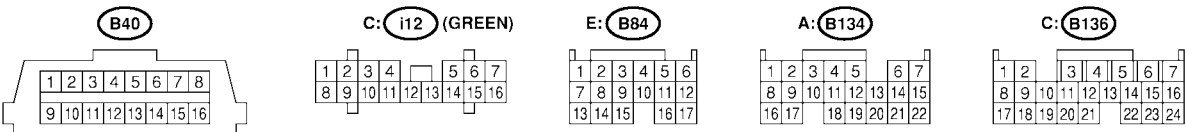
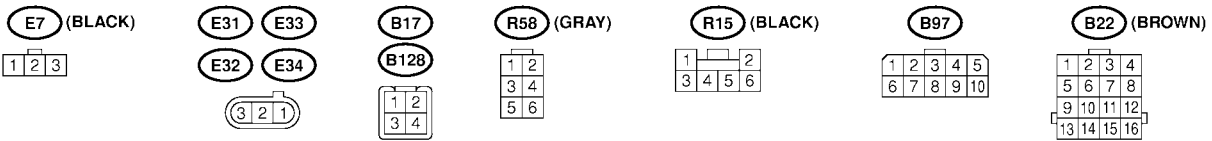
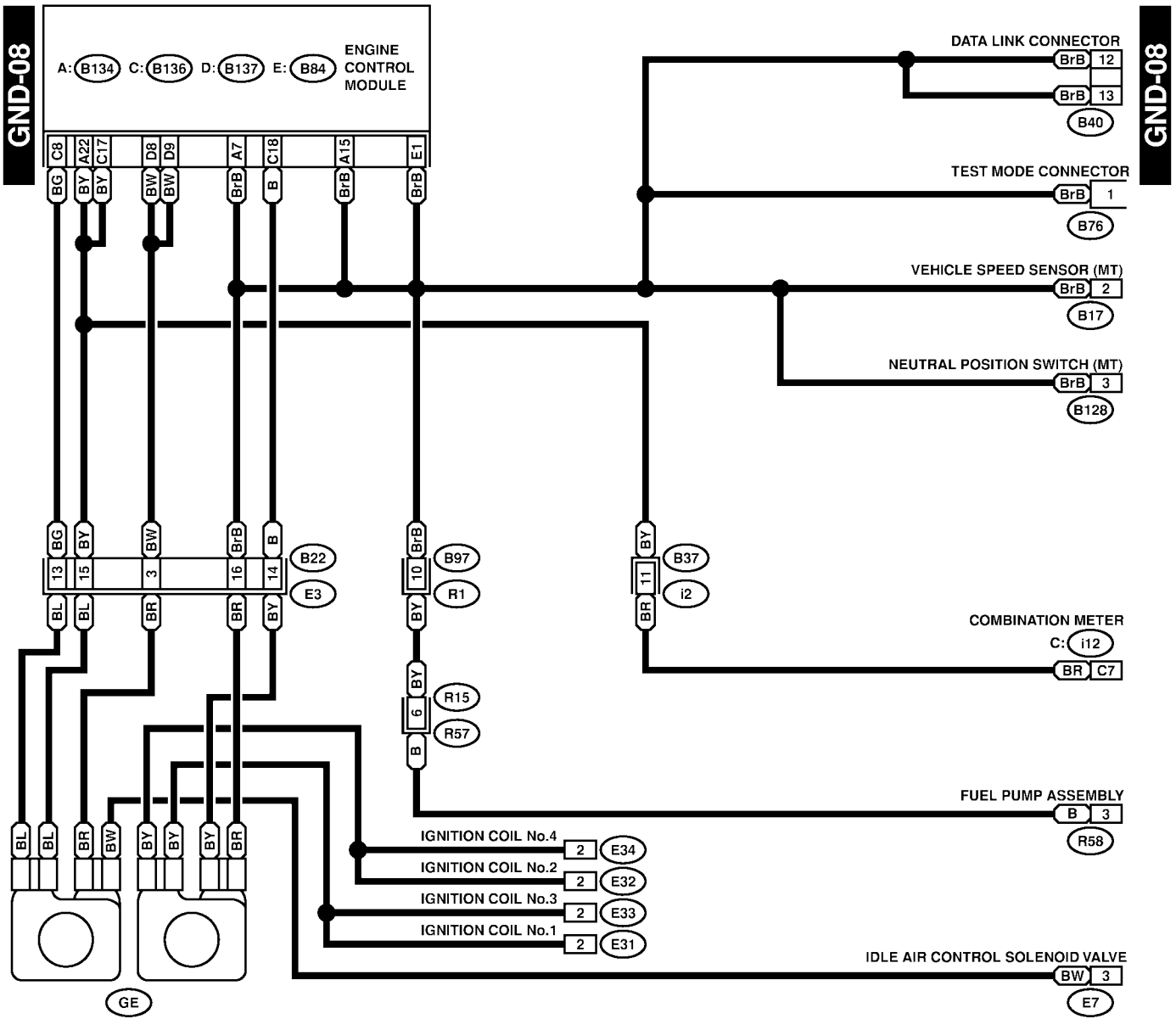

SG04-20H

GROUND DISTRIBUTION

Wiring System

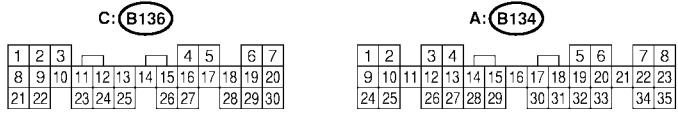
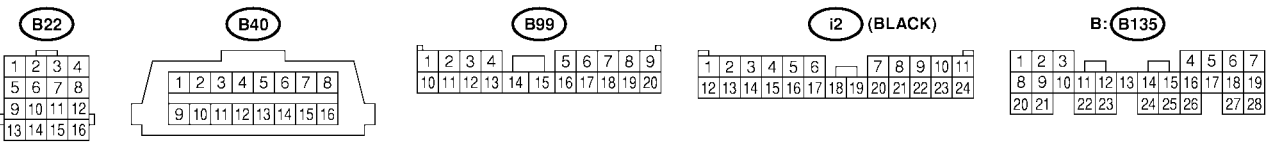
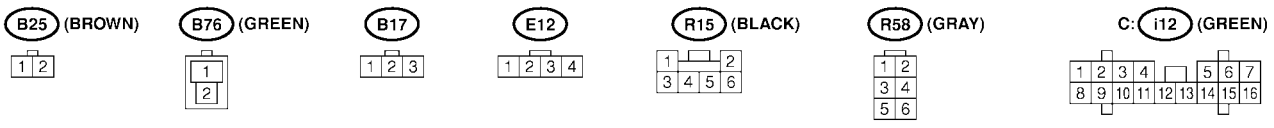
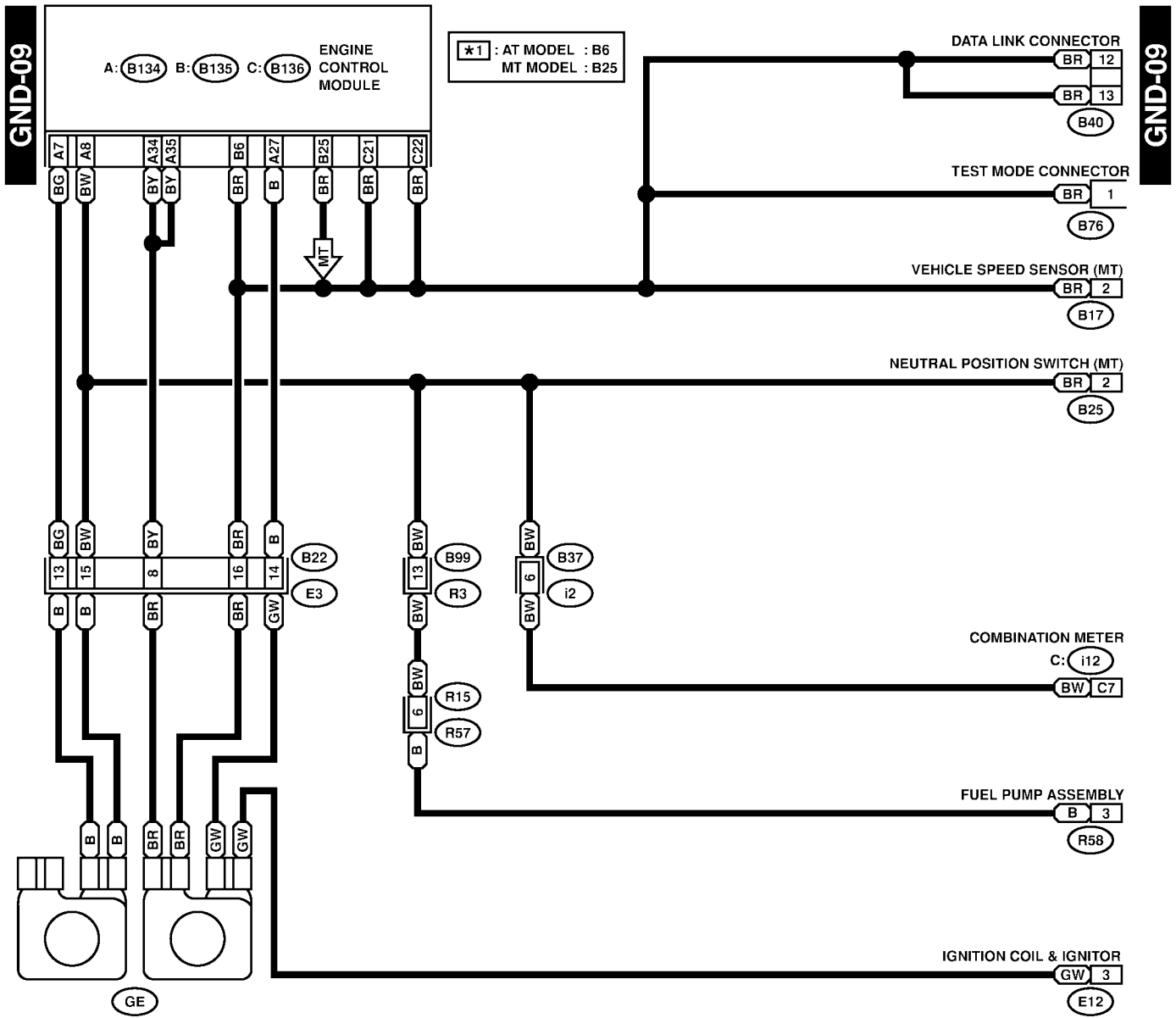

GROUND DISTRIBUTION

Wiring System

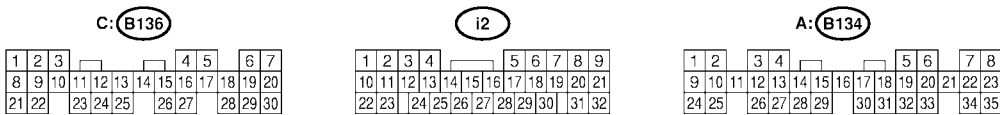
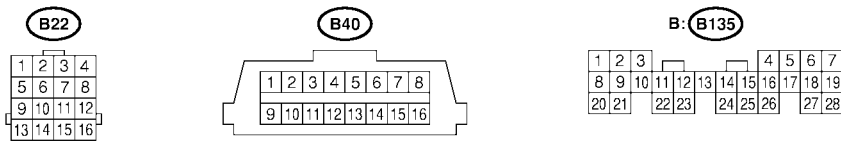
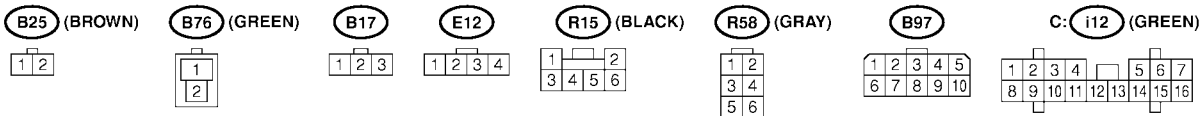
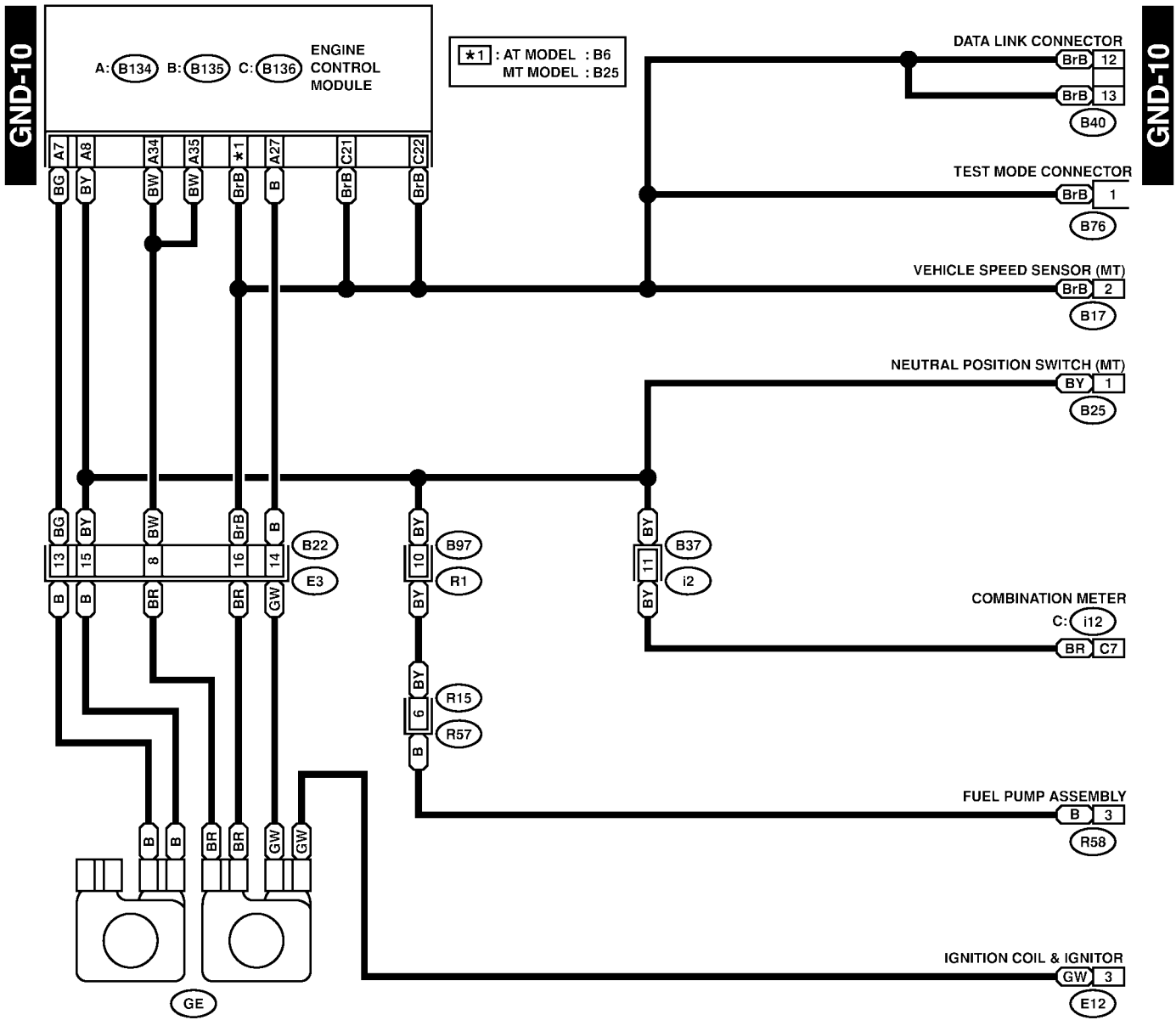

GROUND DISTRIBUTION

Wiring System

GND-11

GND-11

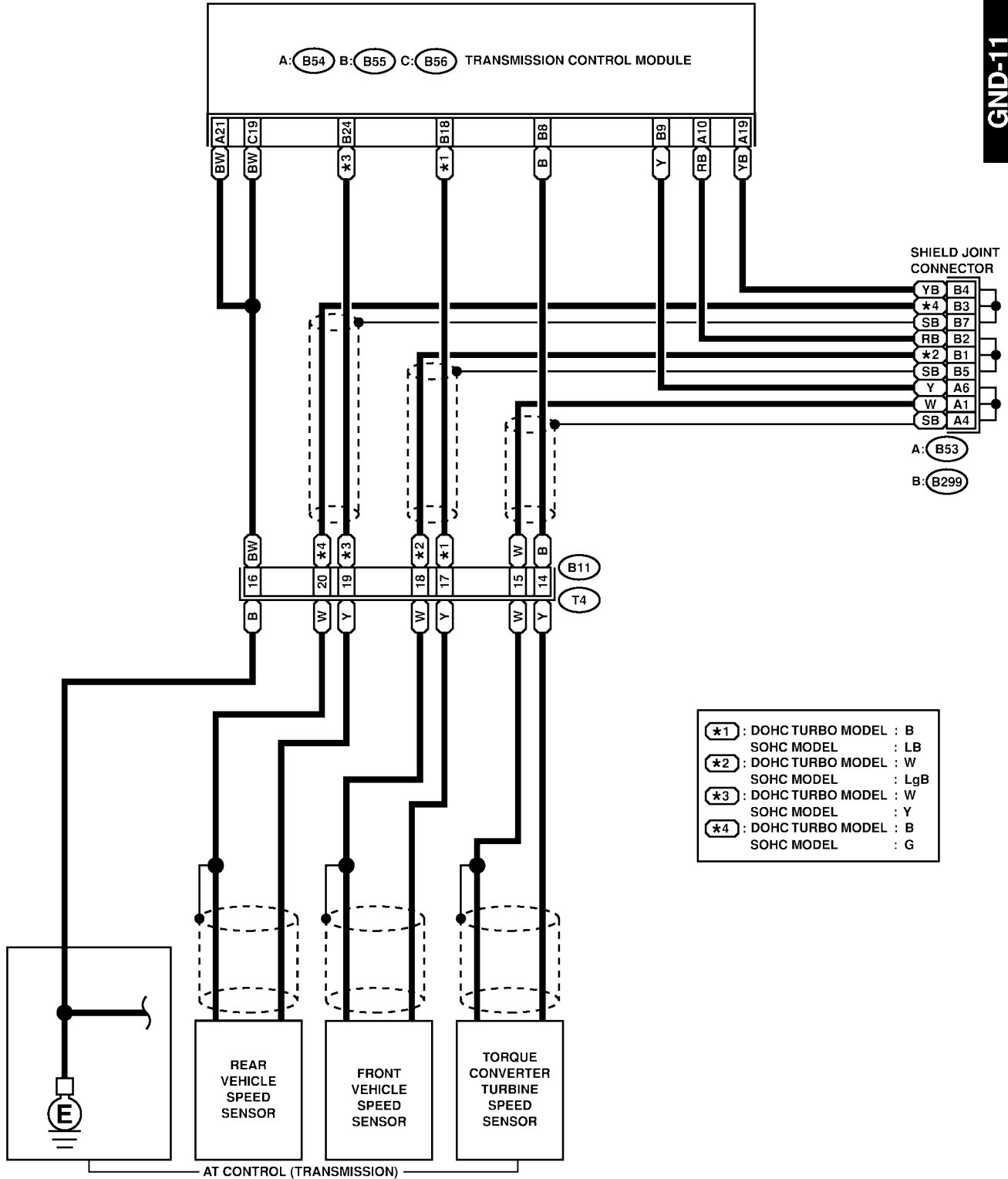

A: B53



B: B299

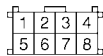

B11

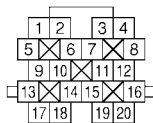

A: B54



B: B55 (GRAY)

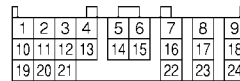

C: B56 (GREEN)

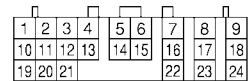

SG04-20K

GROUND DISTRIBUTION

Wiring System

GND-12

GND-12

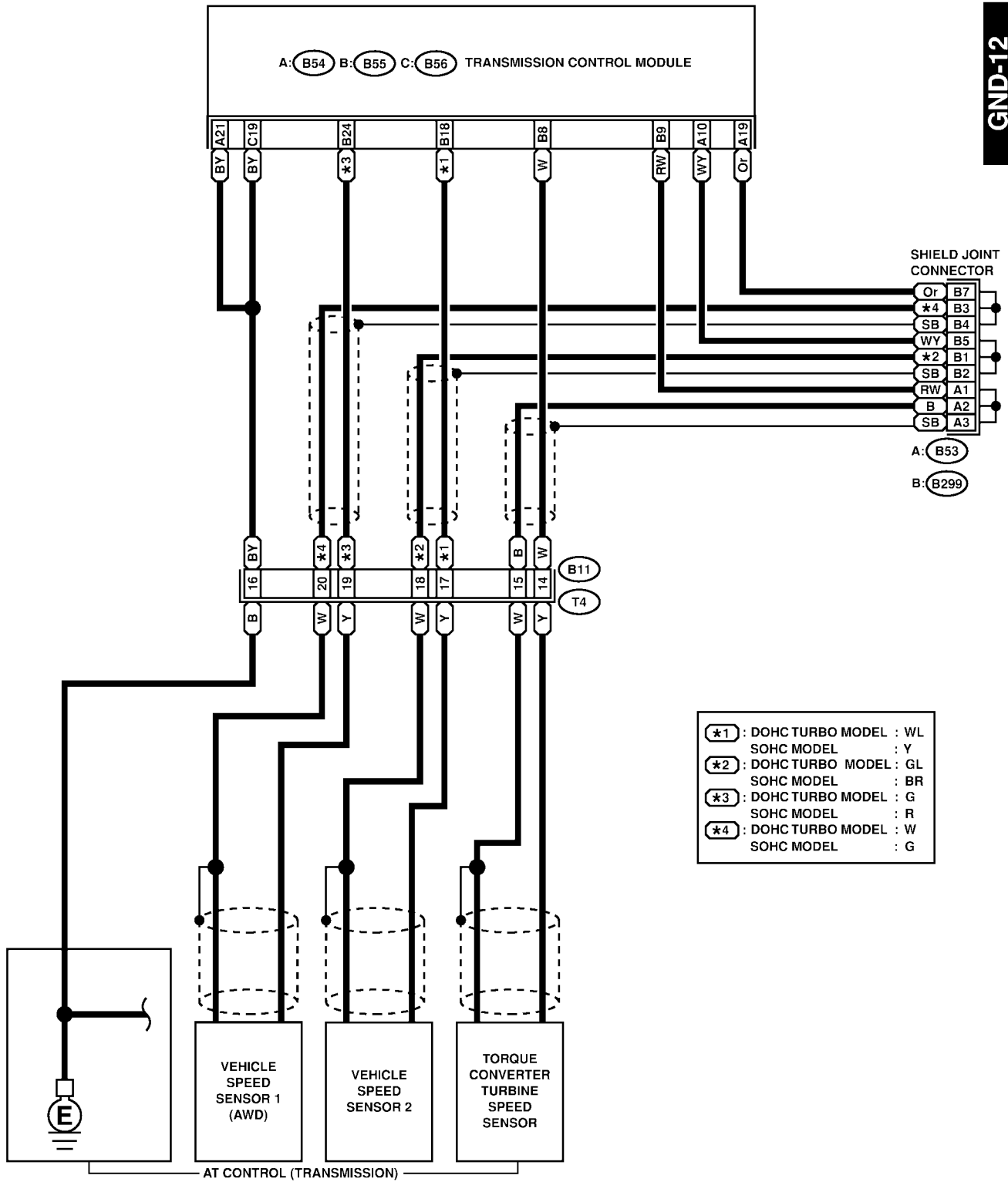

A: B53



B: B299

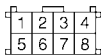

B11

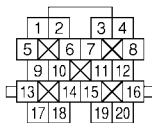

A: B54



B: B55 (GRAY)

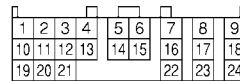

C: B56 (GREEN)

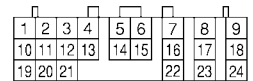

AIRBAG SYSTEM

Wiring System

5. Airbag System S903491

A: SCHEMATIC S903491A21

1. LHD MODEL S903491A2101

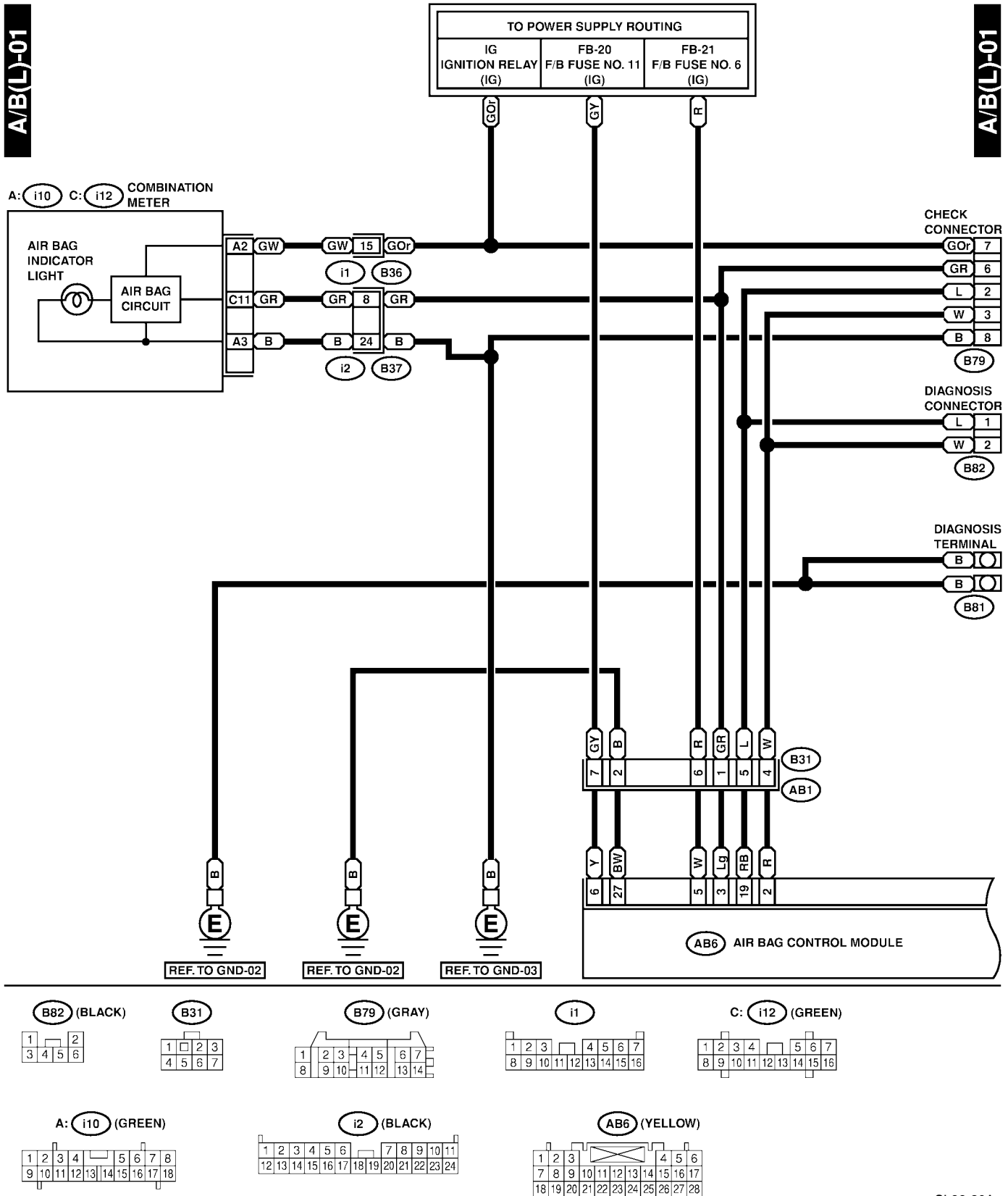

SL86-20A

AIRBAG SYSTEM

Wiring System

A/B(L)-02

A/B(L)-02

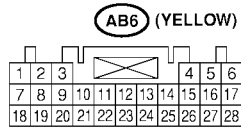
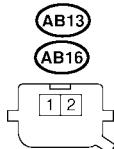
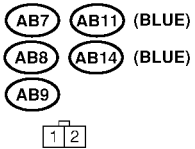
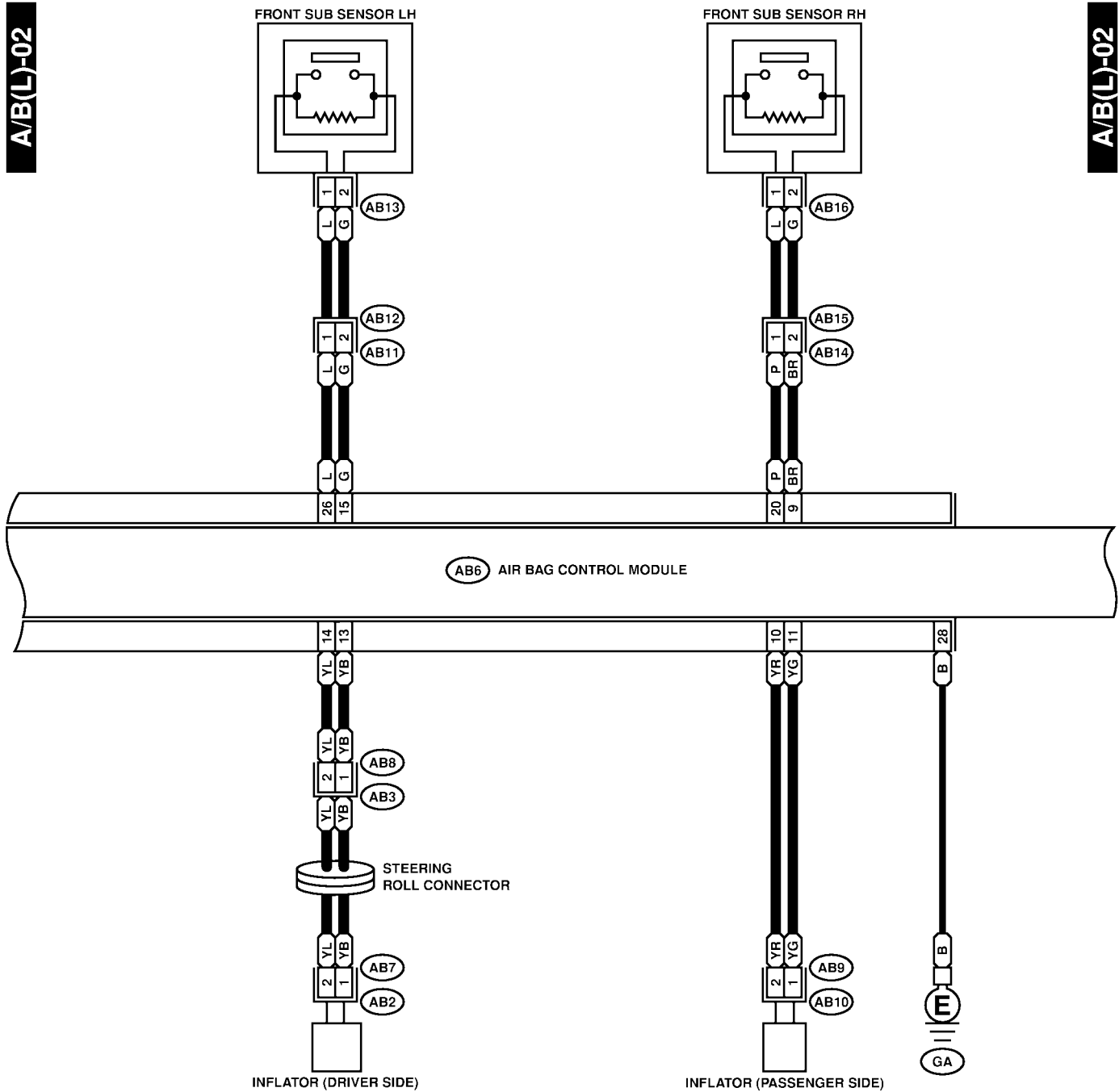

AIRBAG SYSTEM

Wiring System

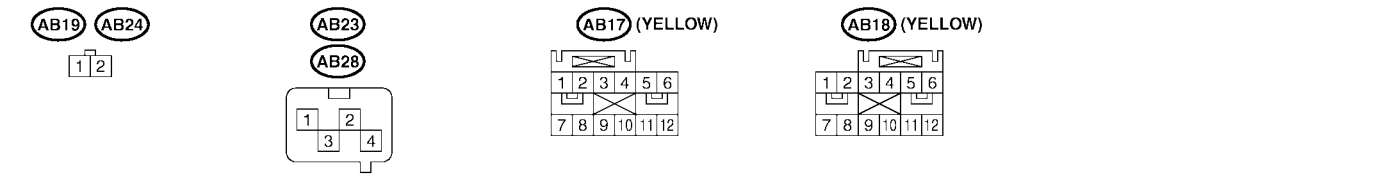
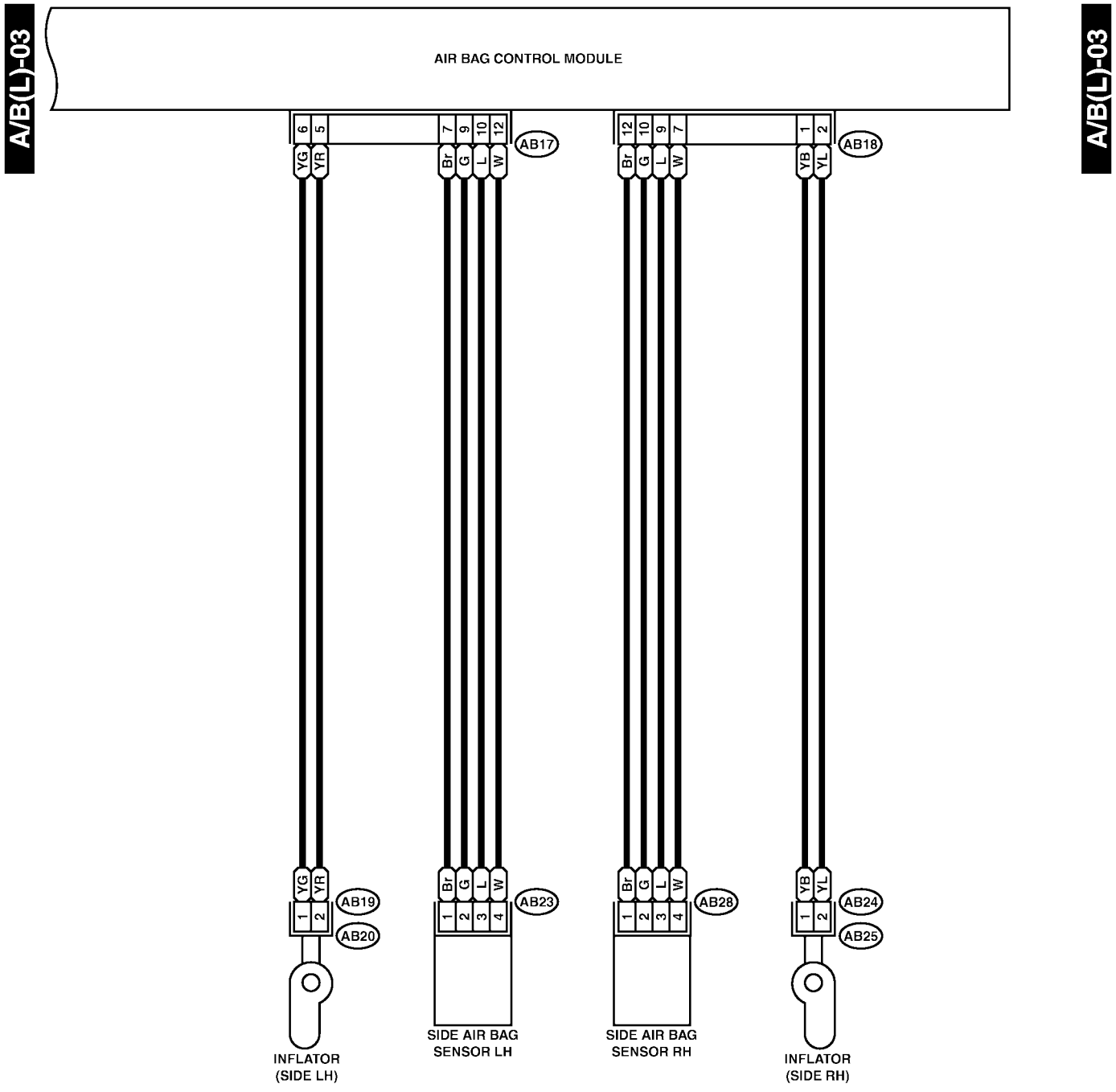

AIRBAG SYSTEM

Wiring System

2. RHD MODEL S903491A2102

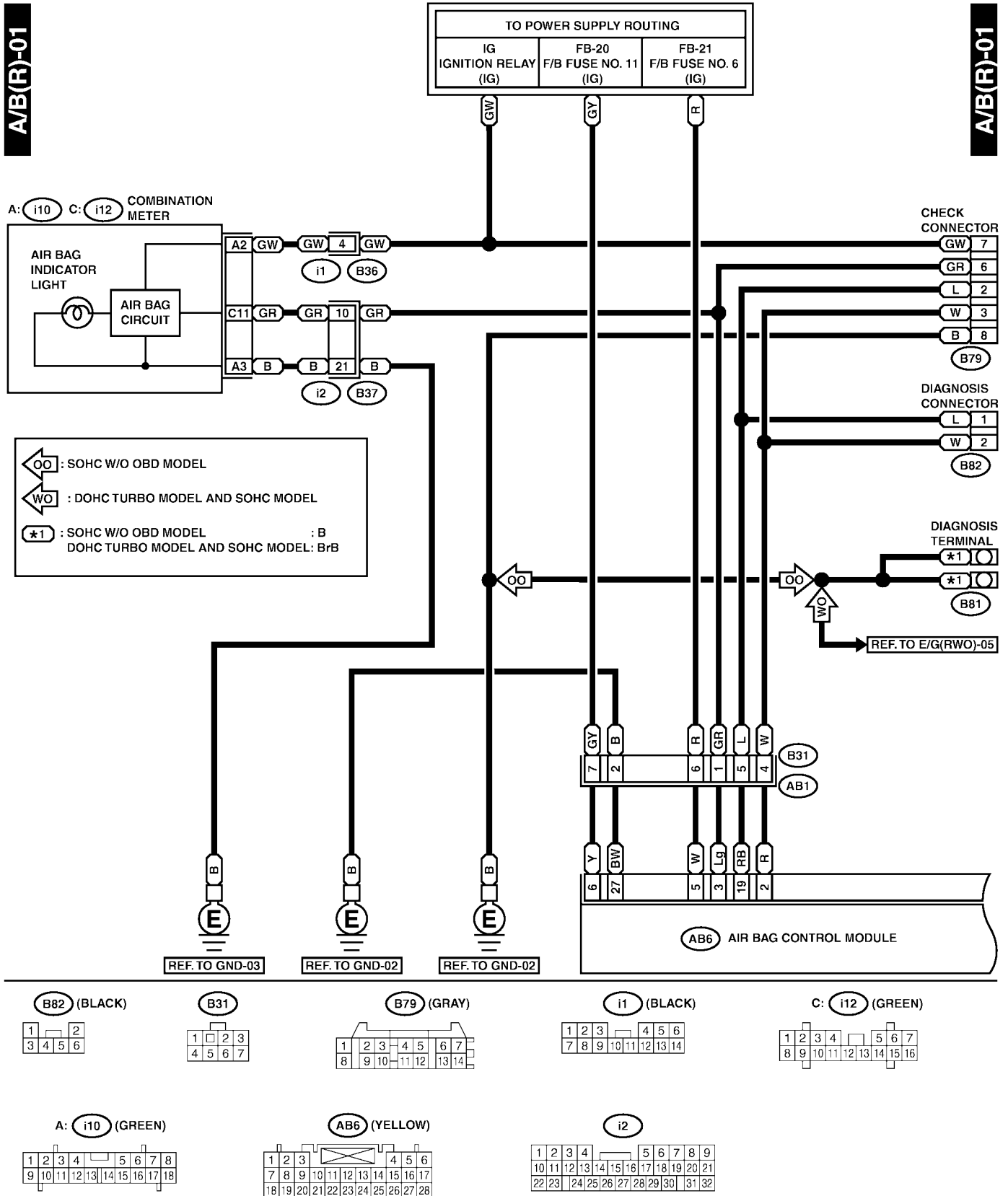

AIRBAG SYSTEM

Wiring System

A/B(R)-02

A/B(R)-02

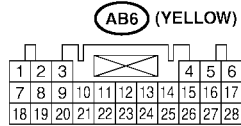
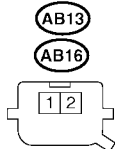
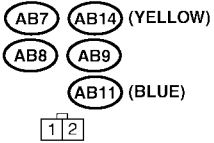
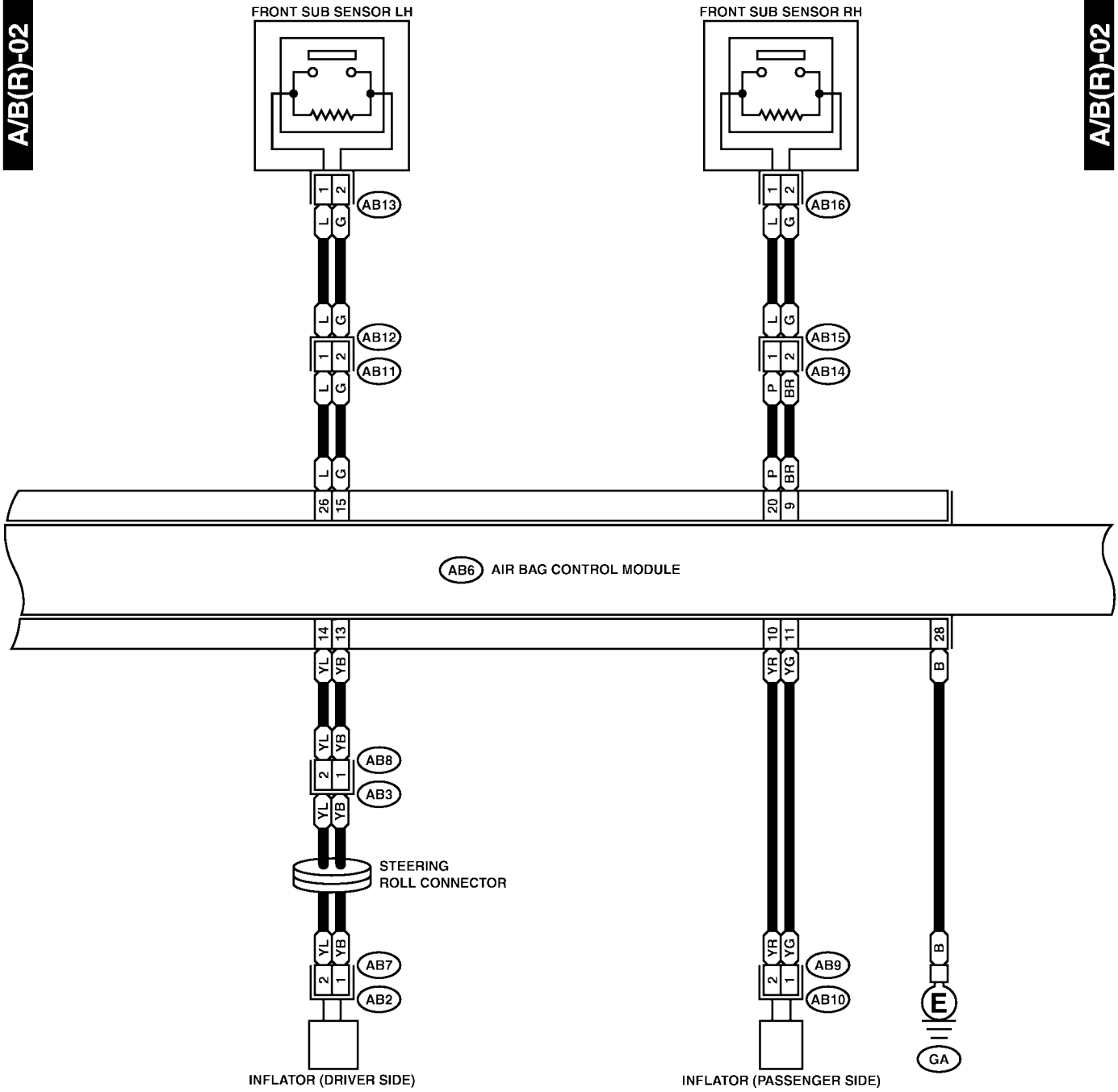

AIRBAG SYSTEM

Wiring System

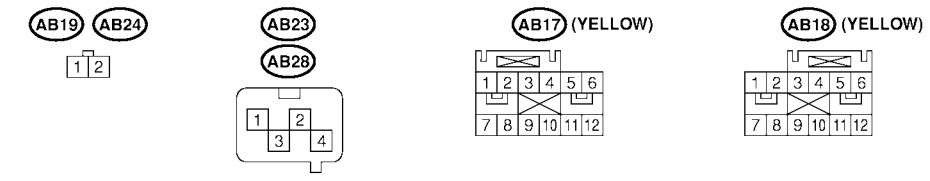
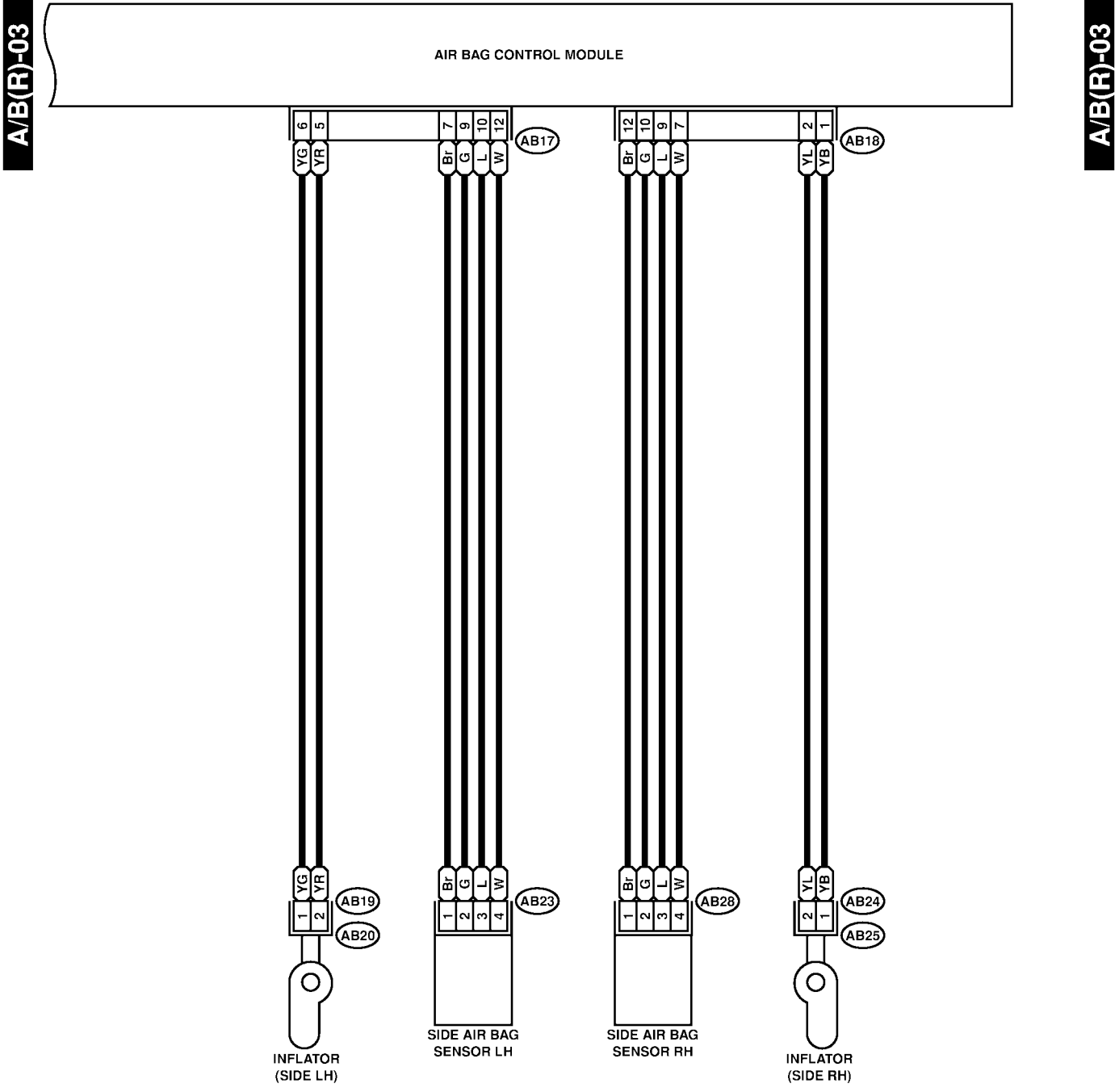

AIR CONDITIONING SYSTEM

Wiring System

6. Air Conditioning System S903471

A: SCHEMATIC S903471A21

1. LHD MODEL S903471A2111

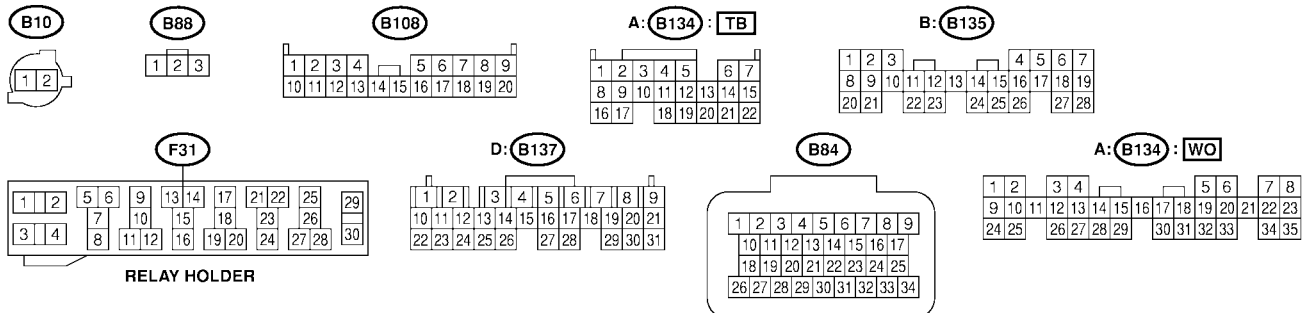
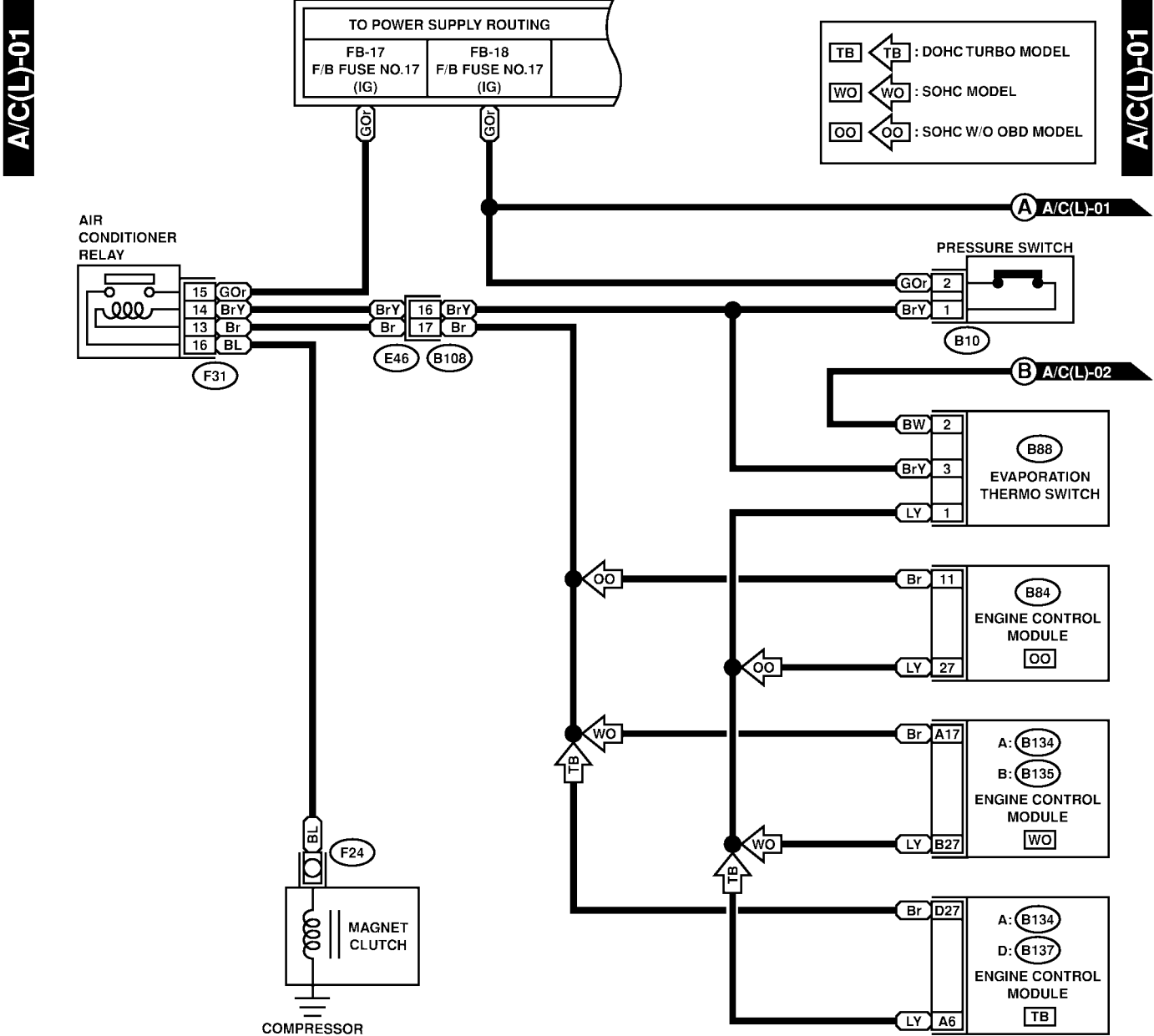

AIR CONDITIONING SYSTEM

Wiring System

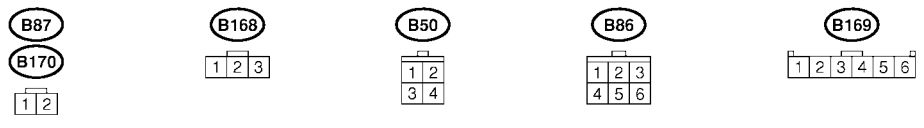
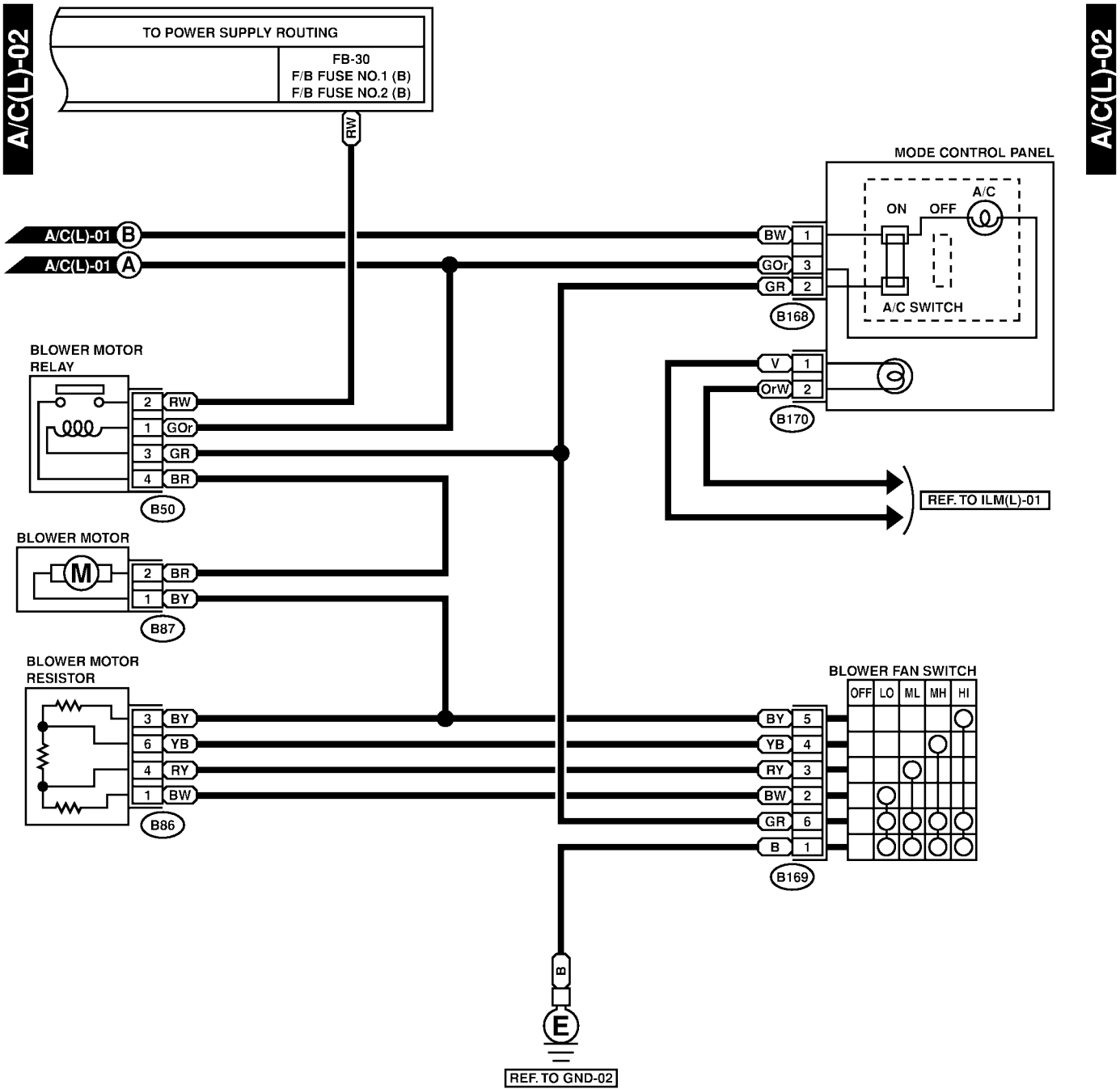

AIR CONDITIONING SYSTEM

Wiring System

2. RHD MODEL S903471A2112

A/C(R)-01

A/C(R)-01

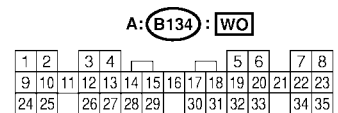
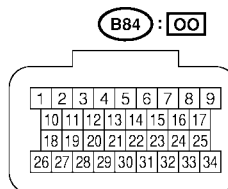
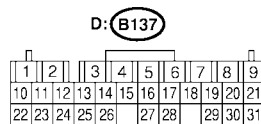
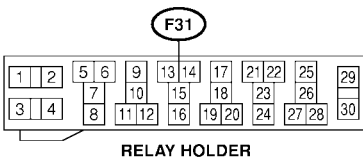
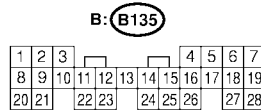
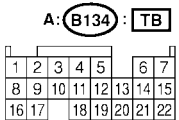
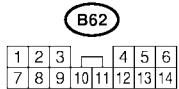
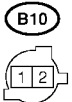
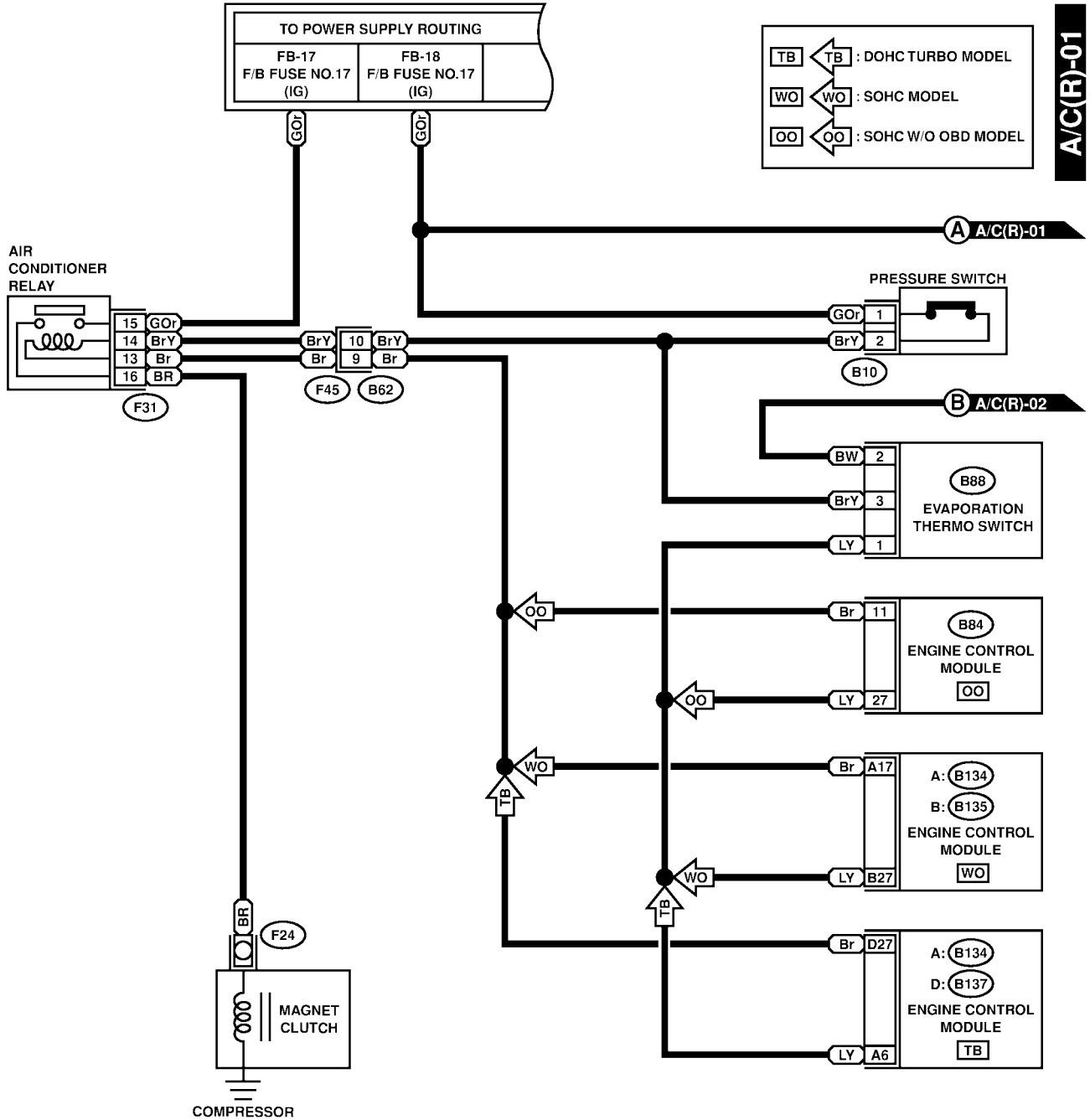

AIR CONDITIONING SYSTEM

Wiring System

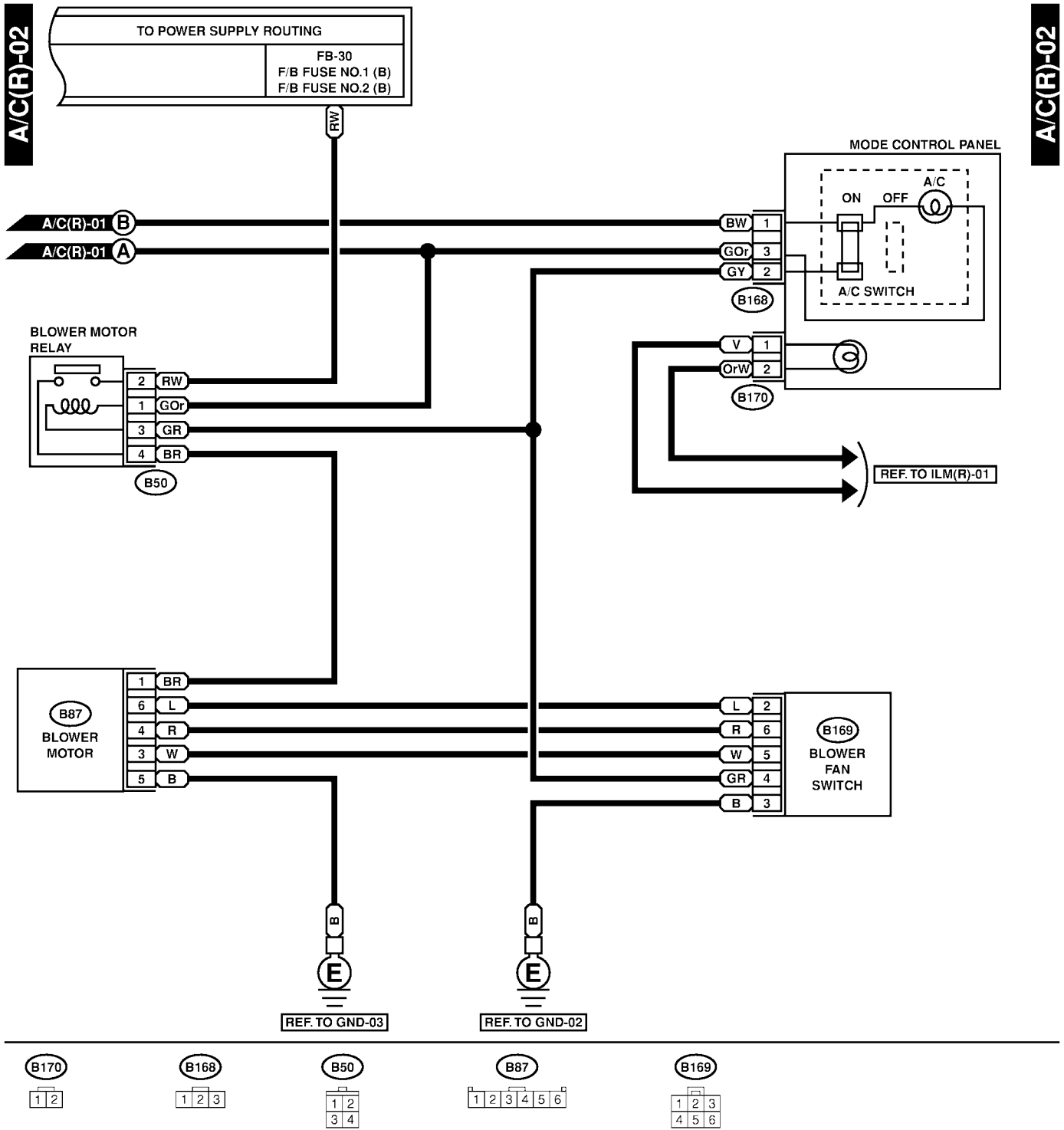

ANTI-LOCK BRAKE SYSTEM

Wiring System

7. Anti-lock Brake System

S903484

A: SCHEMATIC

S903484A21

1. LHD MODEL

S903484A2101

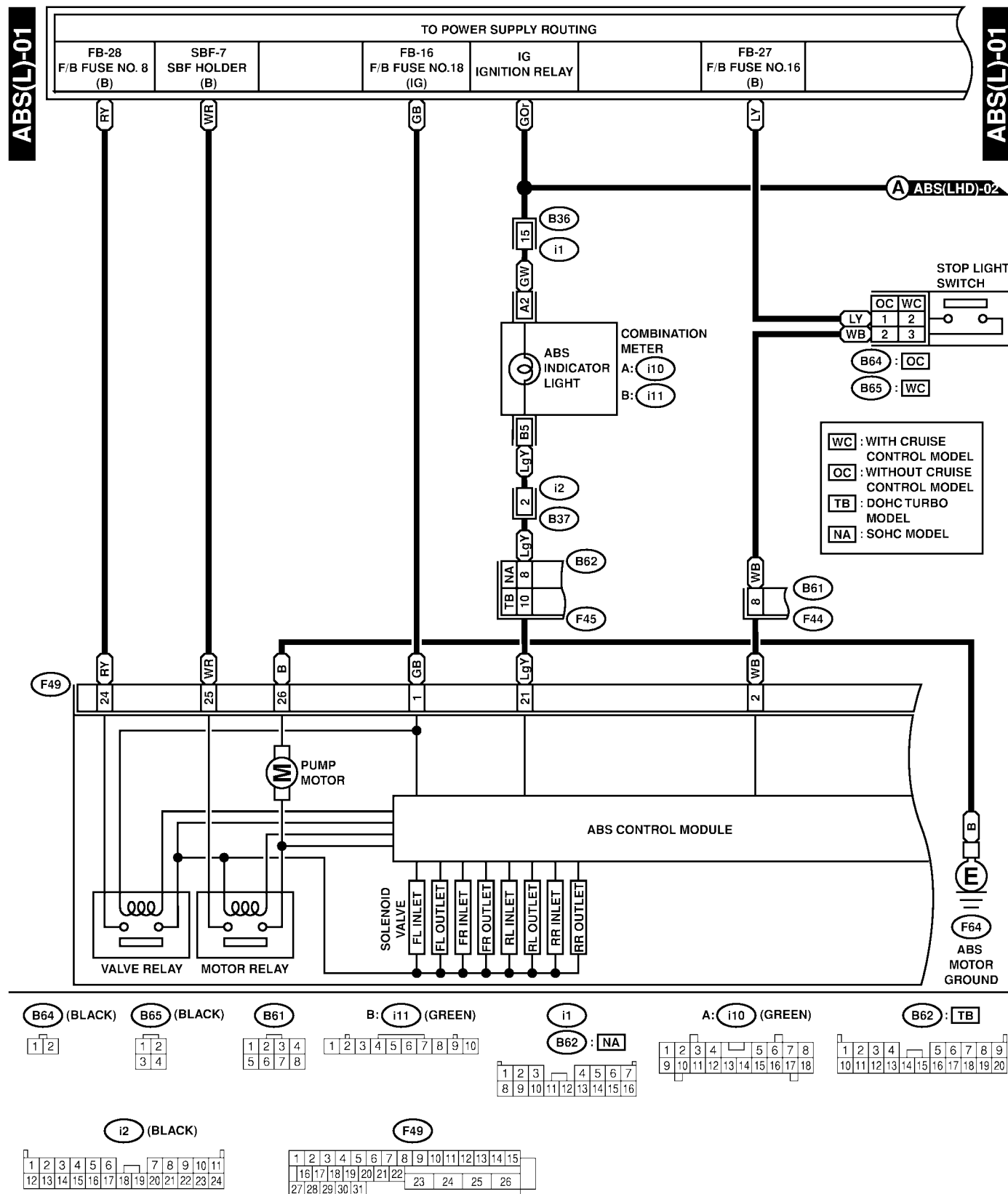

ANTI-LOCK BRAKE SYSTEM

Wiring System

ABS(LHD)-02

ABS(LHD)-02

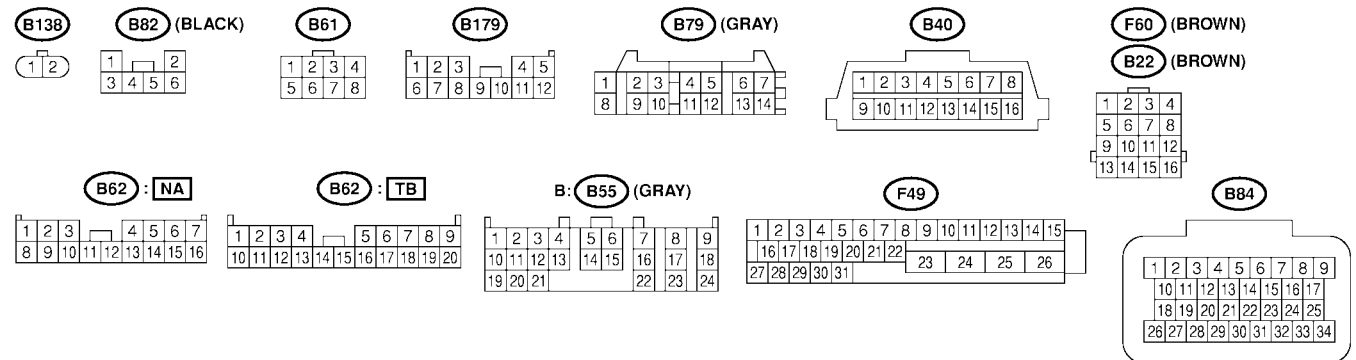
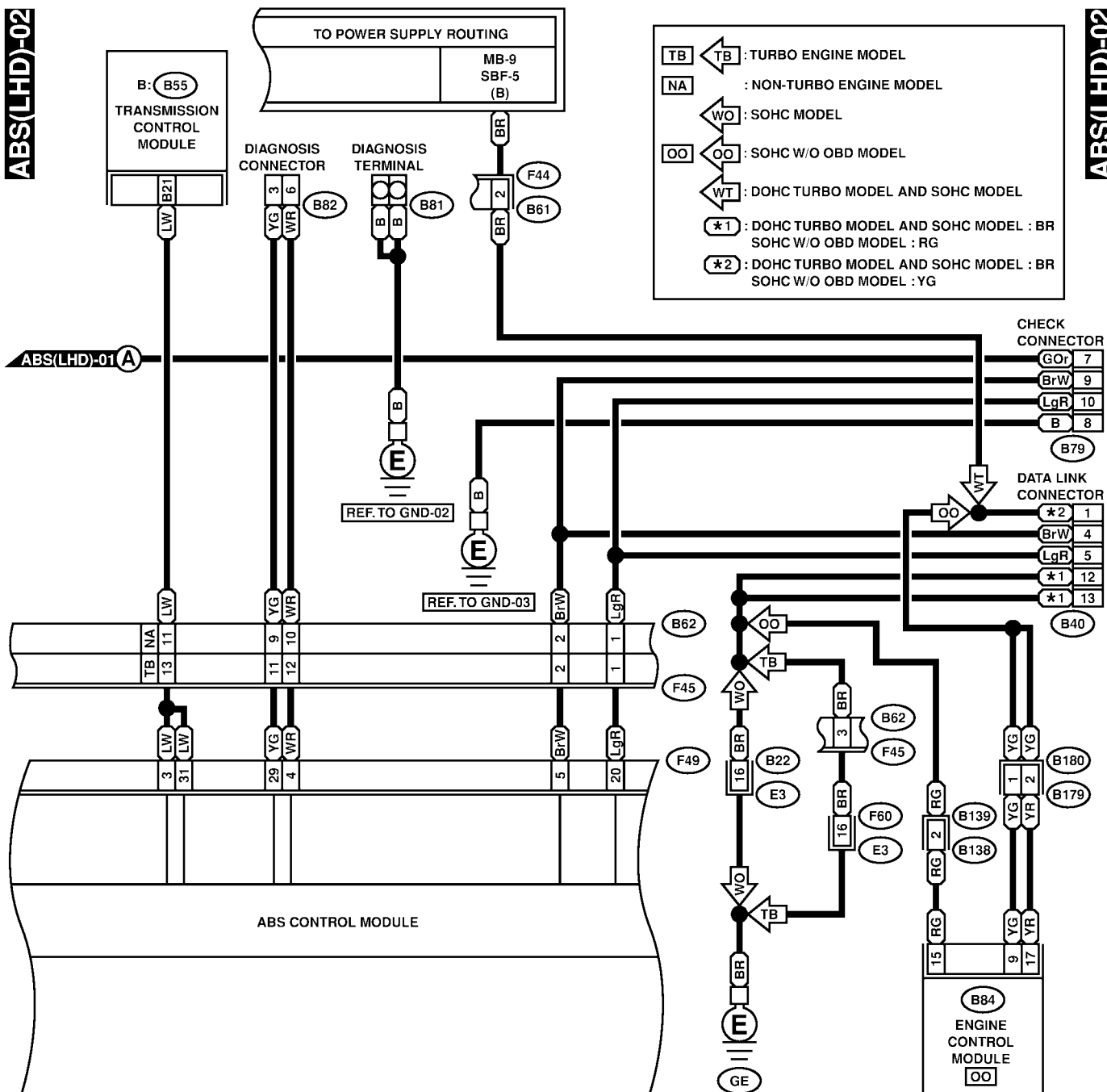

ANTI-LOCK BRAKE SYSTEM

Wiring System

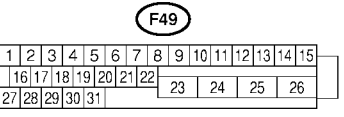
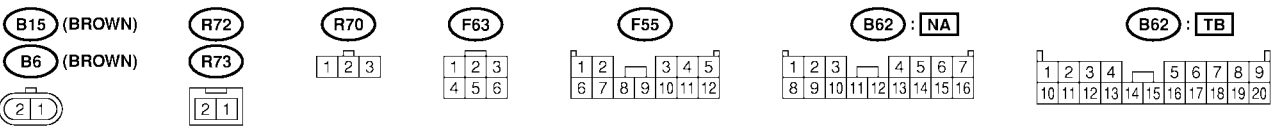
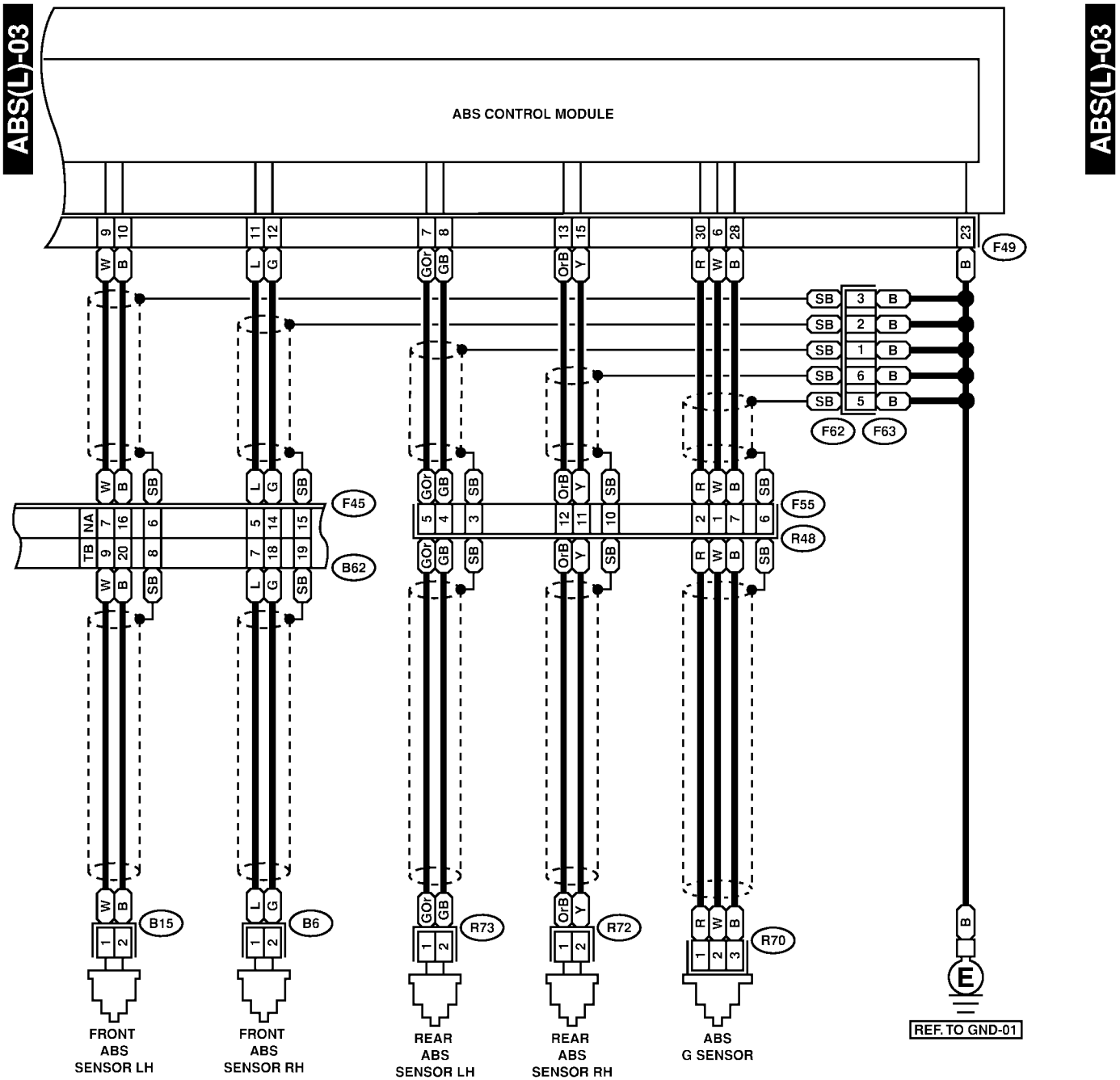

ANTI-LOCK BRAKE SYSTEM

Wiring System

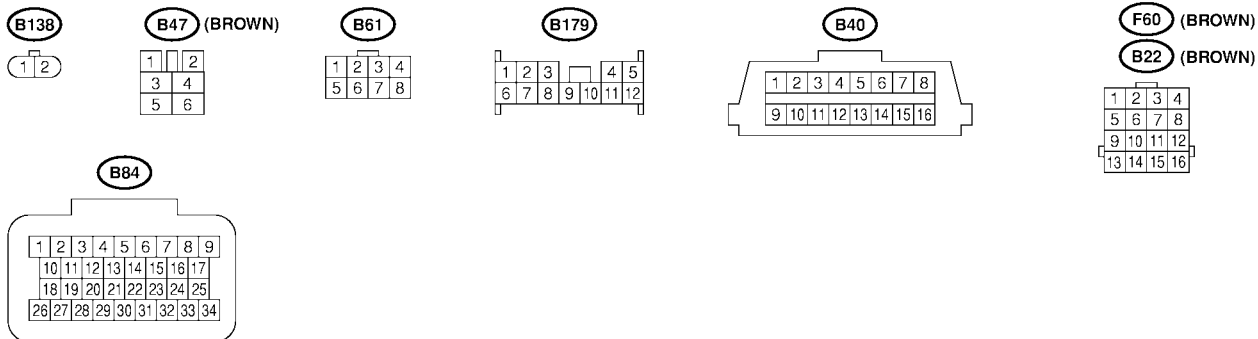
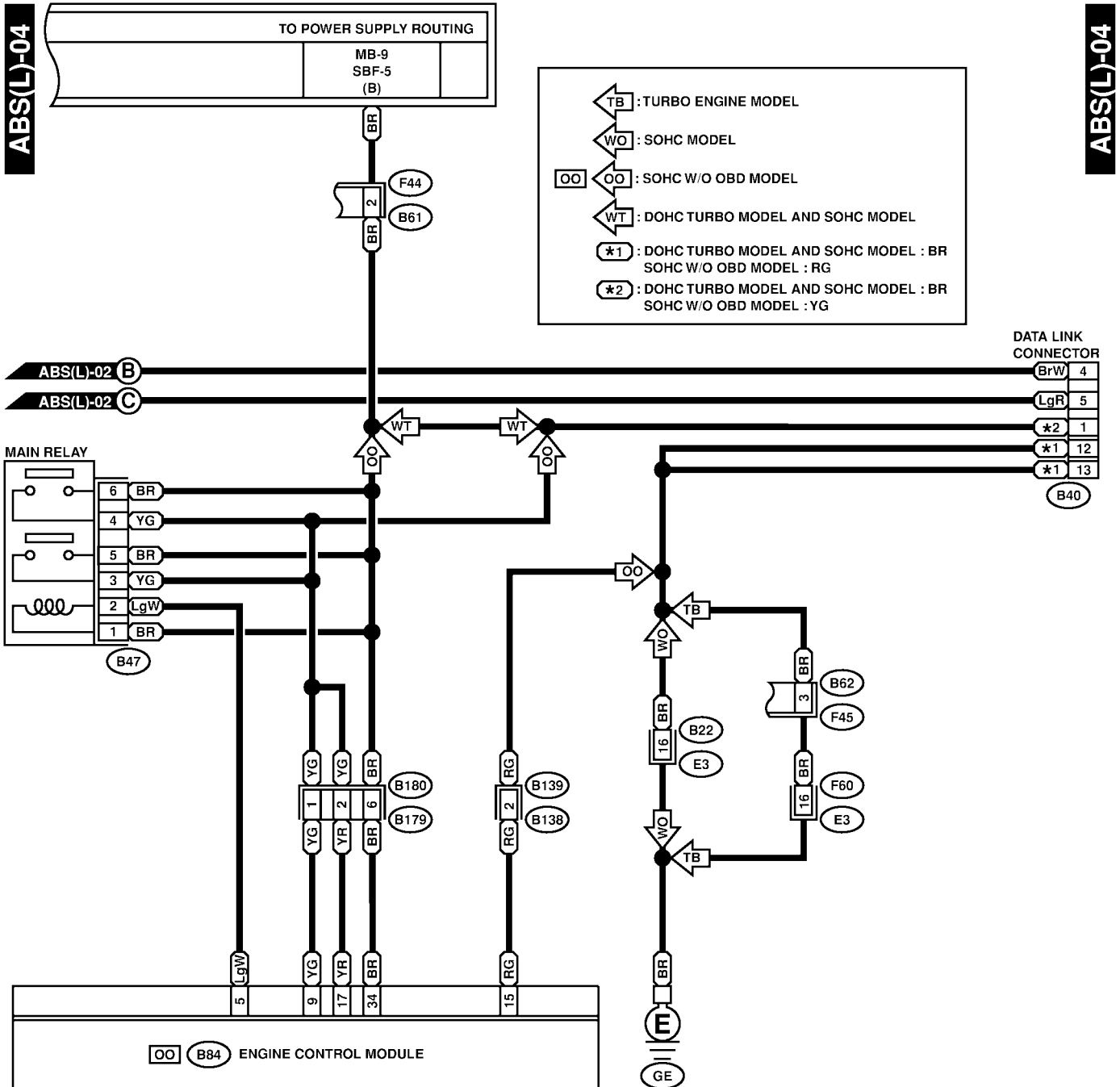

ANTI-LOCK BRAKE SYSTEM

Wiring System

2. RHD MODEL S903484A2102

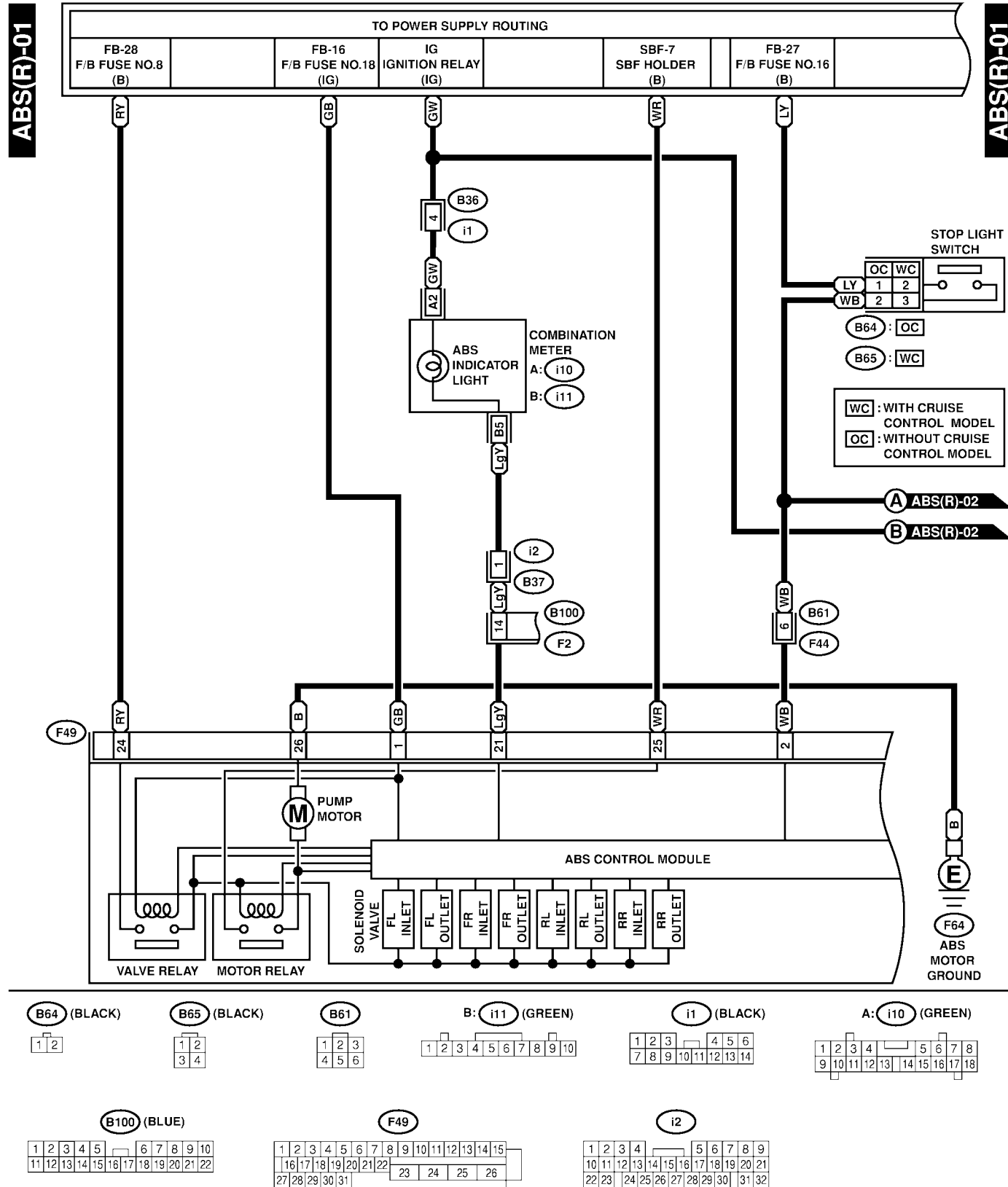

SR82-20A

ANTI-LOCK BRAKE SYSTEM

Wiring System

ABS(R)-02

ABS(R)-02

WO : DOHC TURBO MODEL AND SOHC MODEL
 OO : SOHC W/O OBD MODEL
 *1 : DOHC TURBO MODEL AND SOHC MODEL : BrB
 SOHC W/O OBD MODEL : B

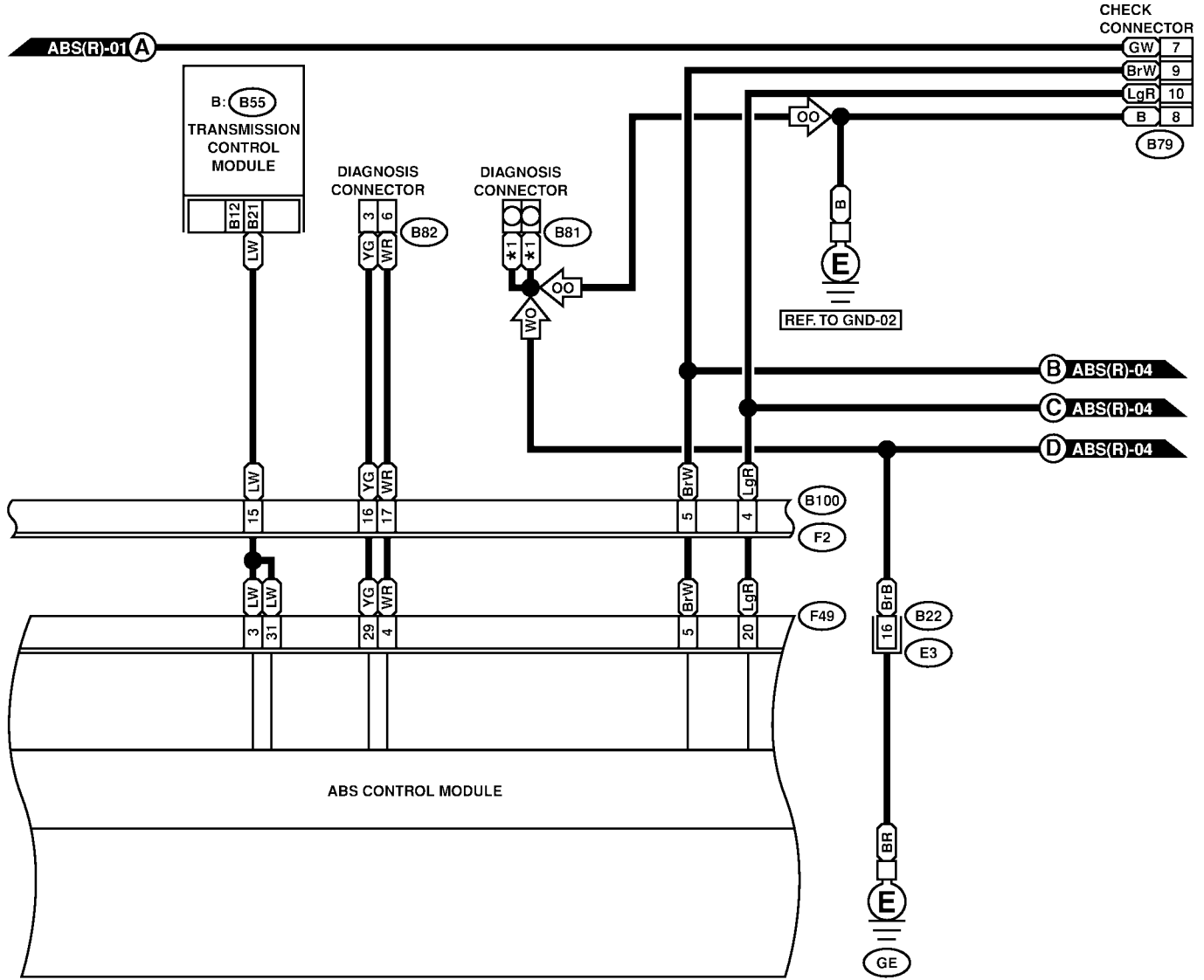

B82 (BLACK)



B79 (GRAY)

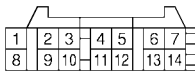

B22 (BROWN)

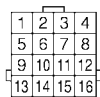

B100 (BLUE)

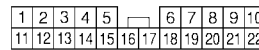

B: B55 (GRAY)

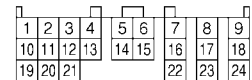

F49

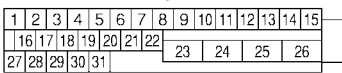

B84

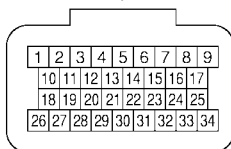

ANTI-LOCK BRAKE SYSTEM

Wiring System

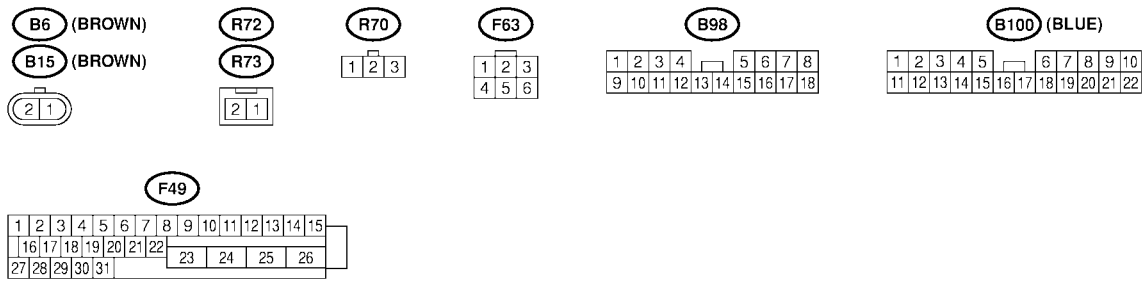
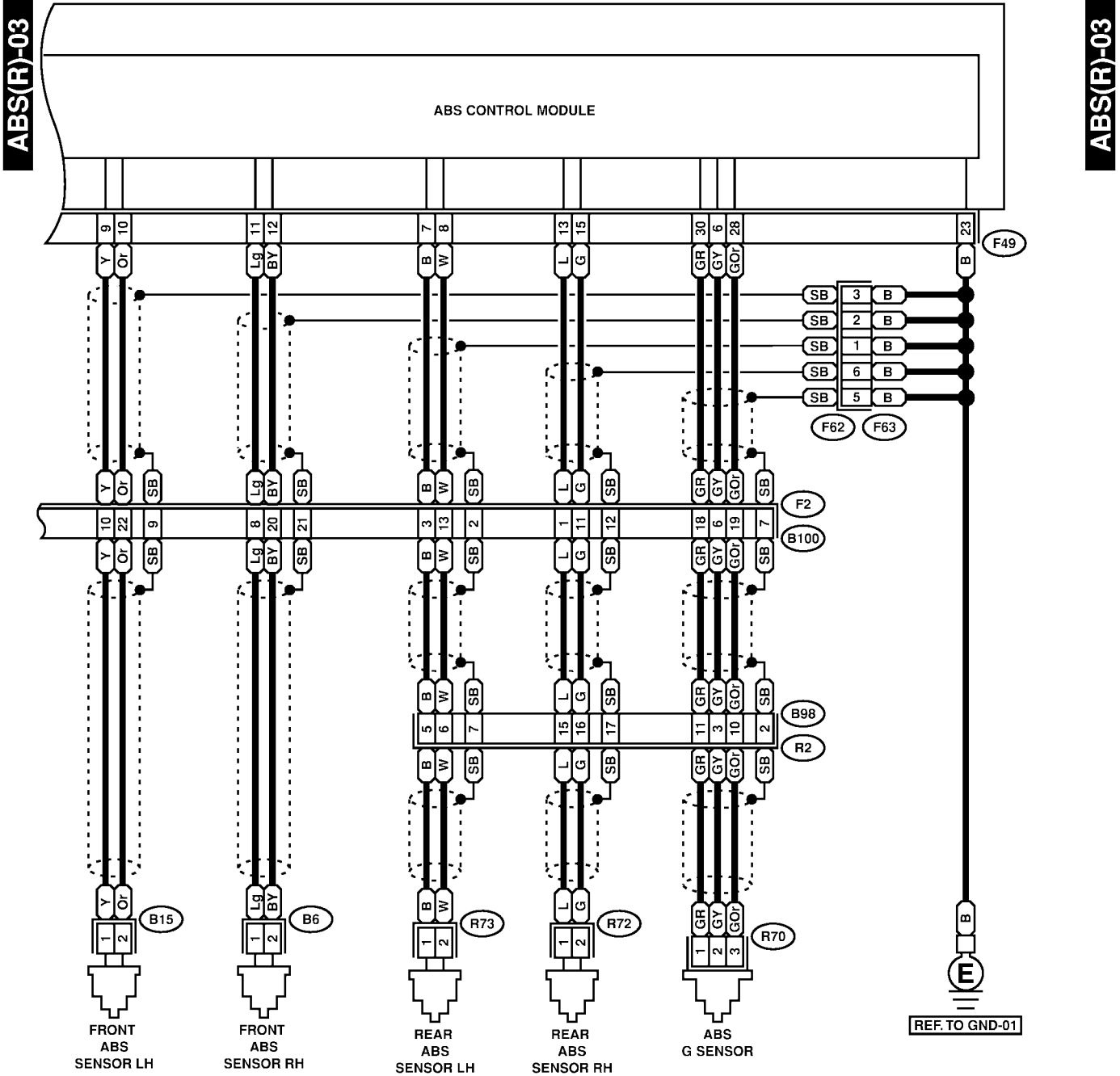

ANTI-LOCK BRAKE SYSTEM

Wiring System

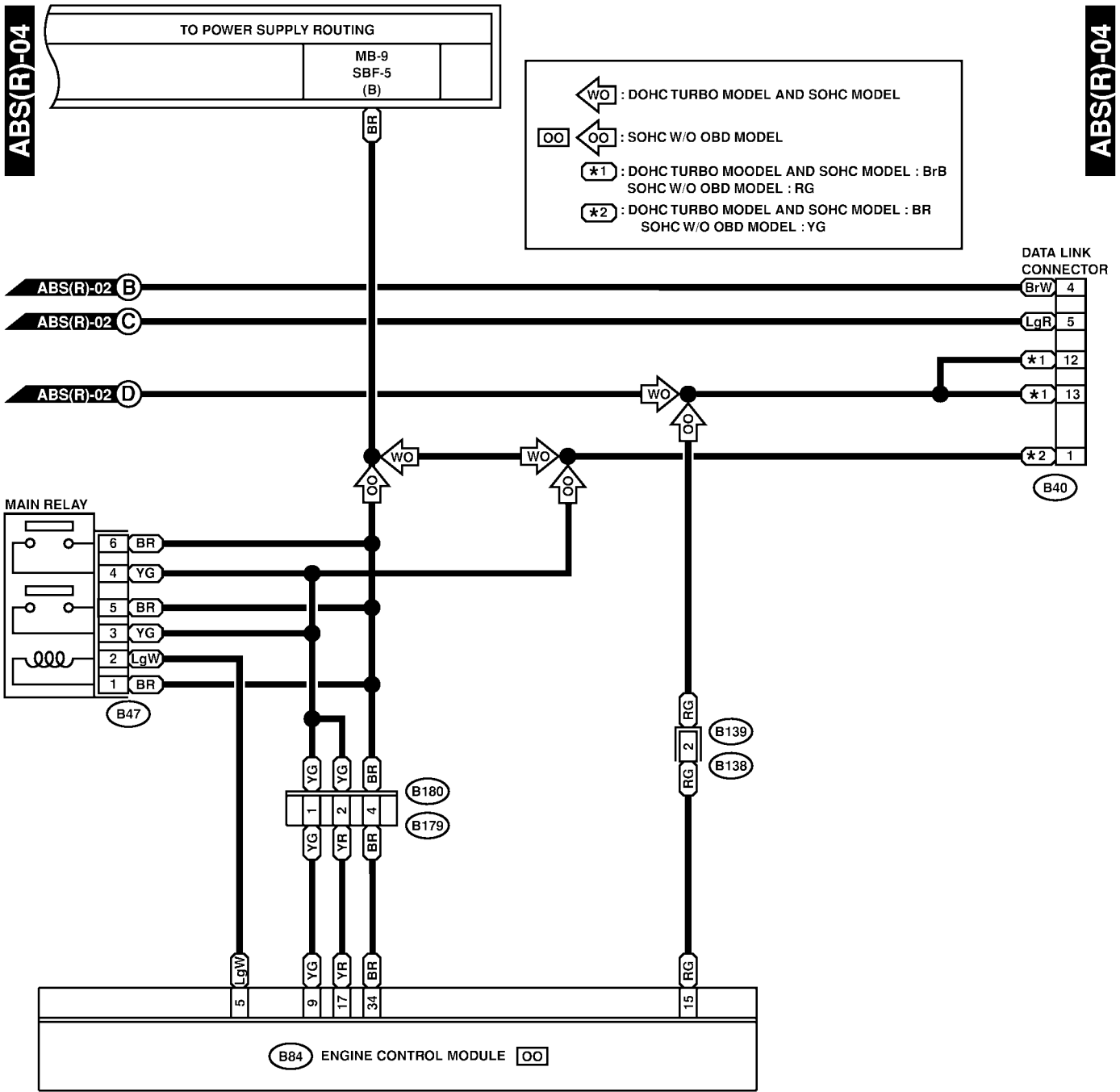

B138



B47 (BROWN)



B179

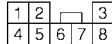

B40

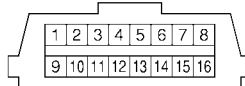

B84

