

FRONT OXYGEN (A/F) SENSOR

FUEL INJECTION (FUEL SYSTEMS)

14. Front Oxygen (A/F) Sensor

A: REMOVAL

1) Disconnect the ground cable from battery.

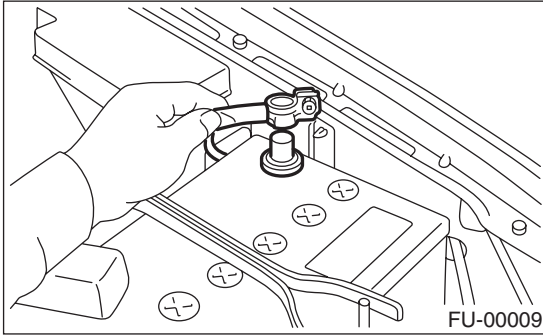

2) Disconnect the connector from the front oxygen (A/F) sensor.

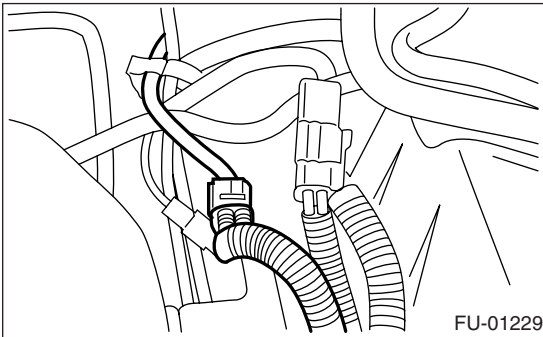

3) Disconnect the engine harness fixed by clip (A) from the bracket (B).

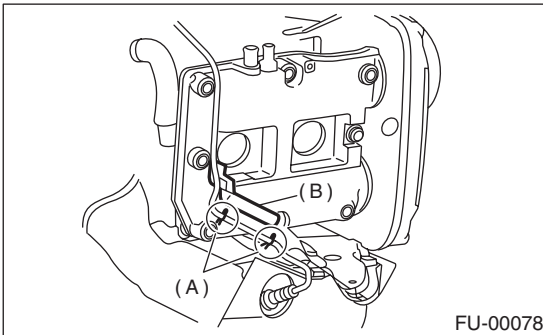

4) Remove the front right side wheel.

5) Lift-up the vehicle.

6) Remove the service hole cover.

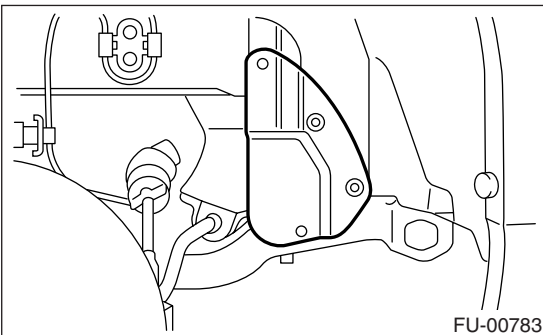

7) Apply SUBARU CRC or its equivalent to the threaded portion of front oxygen (A/F) sensor, and leave it for one minute or more.

SUBARU CRC (Part No. 004301003)

8) Remove the front oxygen (A/F) sensor.

CAUTION:

When removing the oxygen (A/F) sensor, wait until exhaust pipe cools; otherwise, it will damage exhaust pipe.

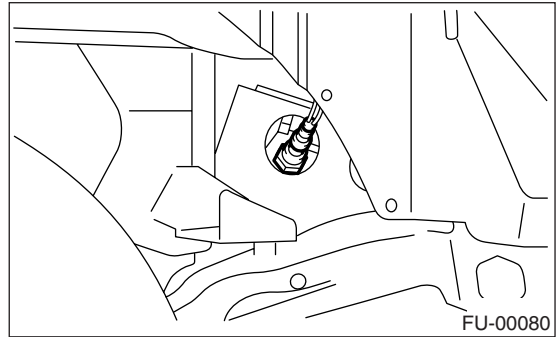

FRONT OXYGEN (A/F) SENSOR

FUEL INJECTION (FUEL SYSTEMS)

B: INSTALLATION

1) Before installing front oxygen (A/F) sensor, apply anti-seize compound only to the threaded portion of front oxygen (A/F) sensor to make the next removal easier.

Anti-seize compound:
SS-30 by JET LUBE

CAUTION:
Never apply anti-seize compound to protector of front oxygen (A/F) sensor.

2) Install the front oxygen (A/F) sensor.

Tightening torque:
30 N·m (3.1 kgf·m, 22.1 ft·lb)

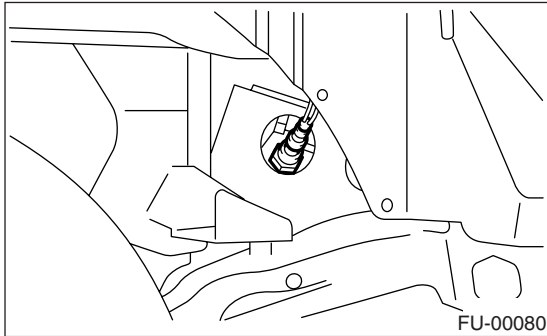

3) Install the service hole cover.

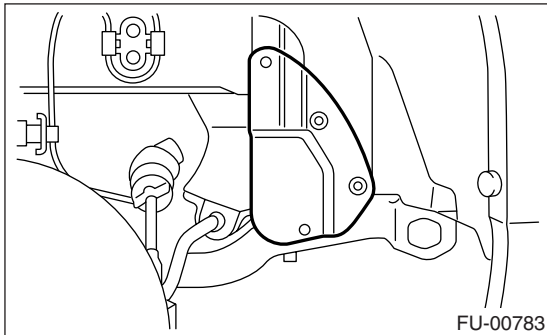

4) Lower the vehicle.

5) Install the front right side wheel.

6) Connect the engine harness to the bracket (B) using clips (A).

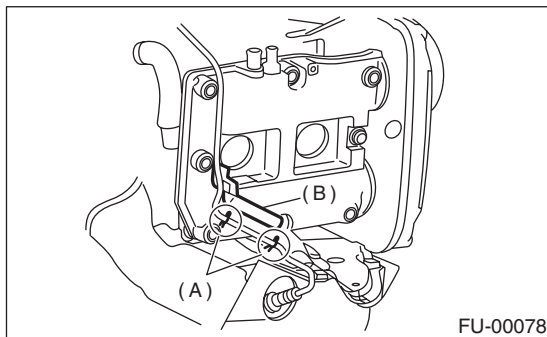

7) Connect the connector of front oxygen (A/F) sensor.

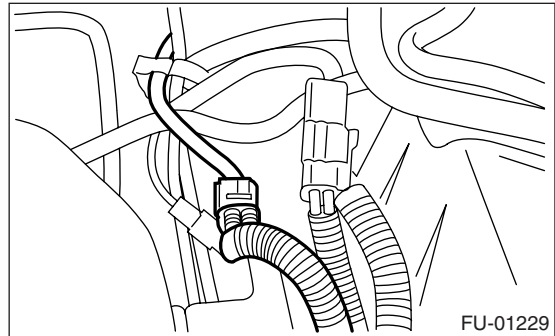

8) Connect the battery ground cable to battery.

