

INTAKE MANIFOLD

FUEL INJECTION (FUEL SYSTEMS)

3. Intake Manifold

A: REMOVAL

- 1) Release the fuel pressure. <Ref. to FU(H4SO)-49, RELEASING OF FUEL PRESSURE, OPERATION, Fuel.>
- 2) Open the fuel filler flap lid, and remove the fuel filler cap.
- 3) Disconnect the ground cable from battery.

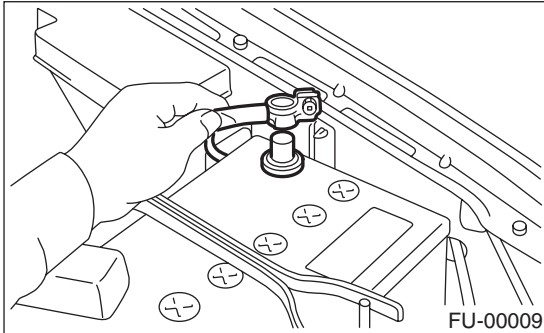

- 4) Remove the air intake duct and air cleaner case. <Ref. to IN(H4SO)-7, REMOVAL, Air Intake Duct.> <Ref. to IN(H4SO)-6, REMOVAL, Air Cleaner Case.>
- 5) Disconnect the accelerator cable (A).
- 6) Disconnect the cruise control cable (B). (With cruise control model)

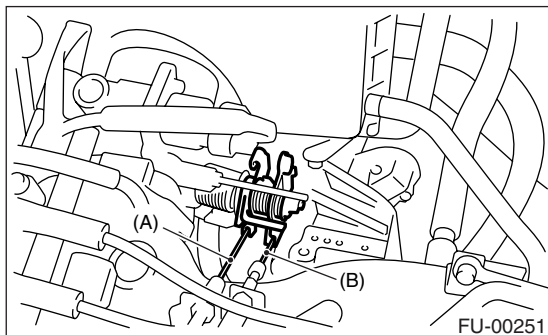

- 7) Remove the power steering pump and reservoir tank from bracket.
 - (1) Remove the resonator chamber. <Ref. to IN(H4SO)-8, REMOVAL, Resonator Chamber.>
 - (2) Remove the front side V-belt. <Ref. to ME(H4SO)-42, REMOVAL, V-belt.>

- (3) Remove the bolts which hold power steering pipes onto the intake manifold protector.

CAUTION:

Do not disconnect the power steering hose.

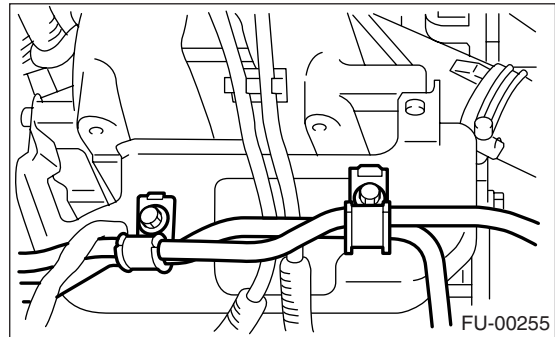

- (4) Remove the bolts which secure power steering pump bracket.

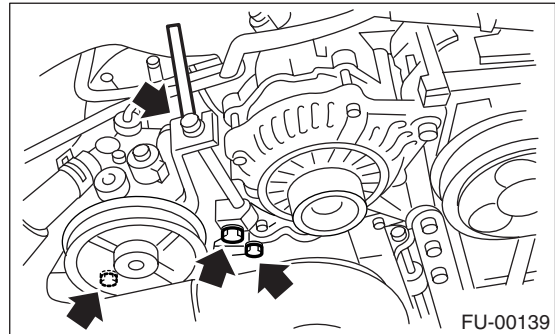

- (5) Disconnect the connector from the power steering pump switch.

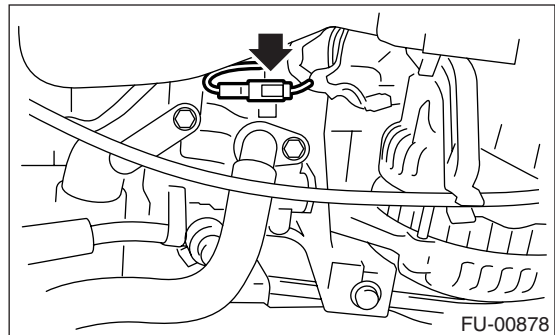

- (6) Remove the power steering tank from the bracket by pulling it upwards.

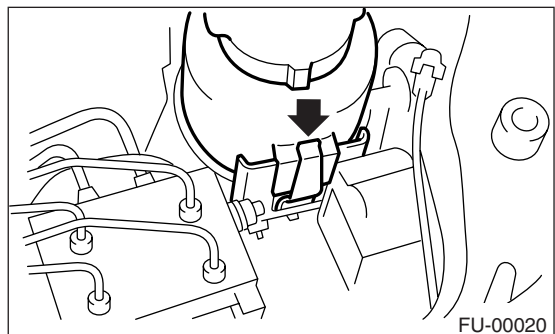

INTAKE MANIFOLD

FUEL INJECTION (FUEL SYSTEMS)

(7) Place the power steering pump on the right side wheel apron.

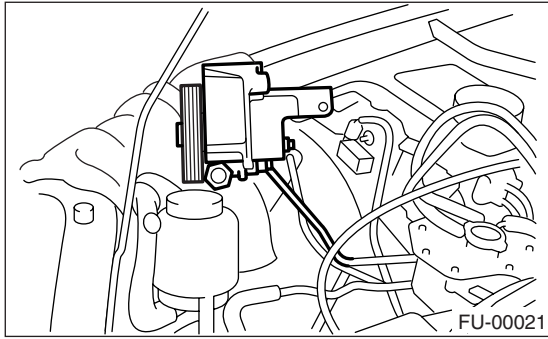

8) Disconnect the spark plug cords from the spark plugs.

9) Disconnect the PCV hose from the intake manifold.

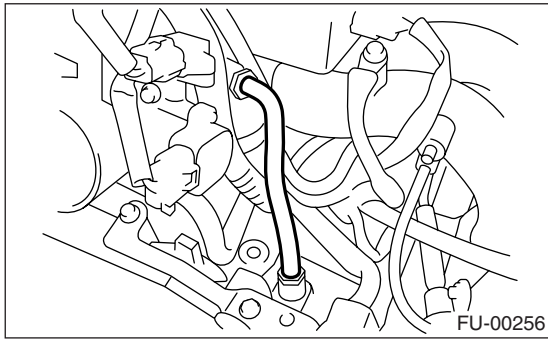

10) Disconnect the engine coolant hose (A) from the throttle body.

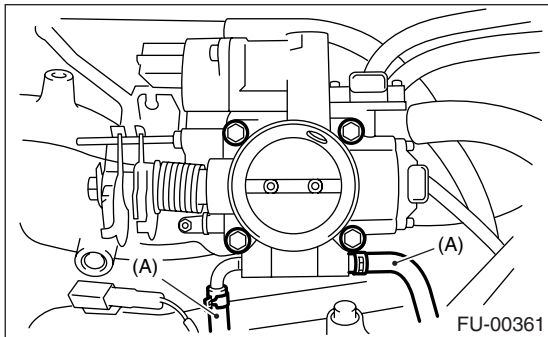

11) Disconnect the brake booster hose.

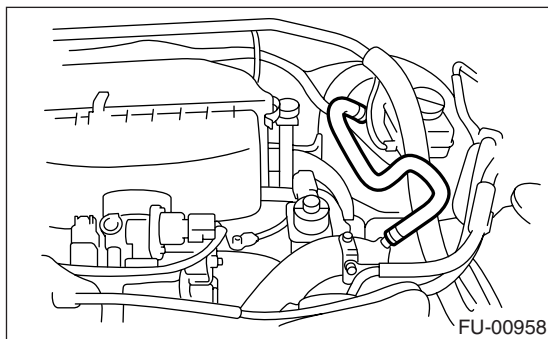

12) Remove the air cleaner case stay RH and engine harness bracket, and disconnect the engine harness connectors from the bulkhead harness connectors.

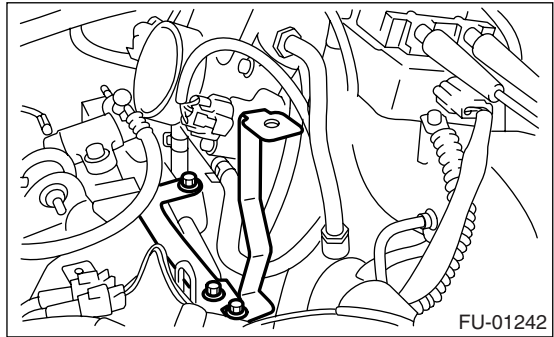

13) Disconnect the connectors from the engine coolant temperature sensor.

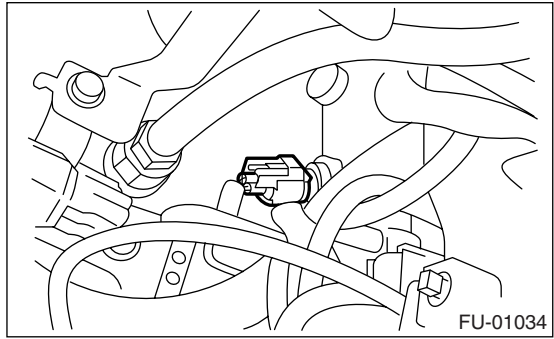

14) Disconnect the knock sensor connector.

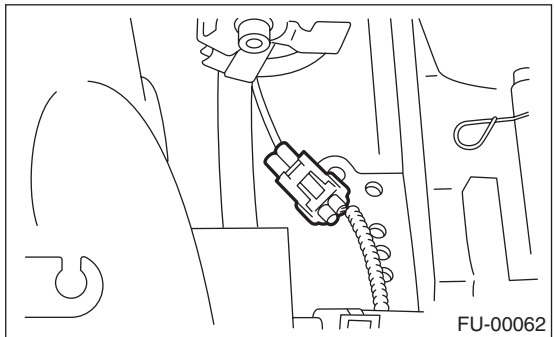

15) Disconnect the connector from the crankshaft position sensor.

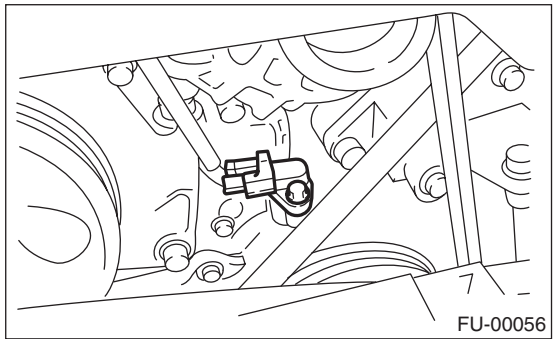

INTAKE MANIFOLD

FUEL INJECTION (FUEL SYSTEMS)

16) Disconnect the connector from the oil pressure switch.

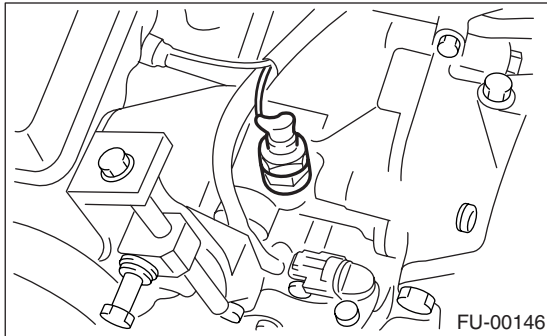

17) Disconnect the connector from the camshaft position sensor.

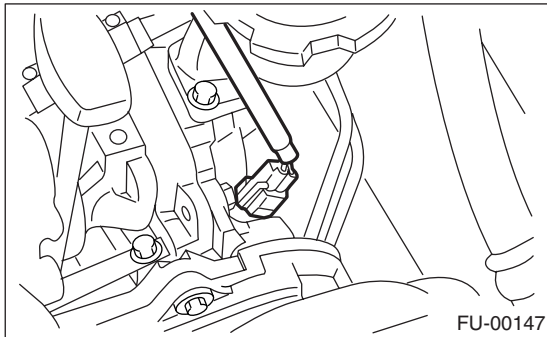

18) Remove the EGR pipe from intake manifold.

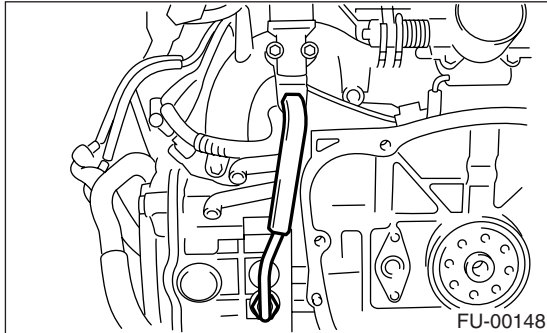

19) Disconnect the fuel hoses from the fuel pipes.

WARNING:

- Do not spill fuel.
- Catch fuel from hoses in a container or cloth.

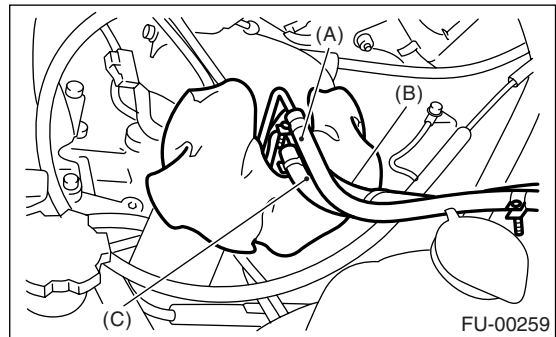

- (A) Fuel delivery hose
- (B) Return hose
- (C) Evaporation hose

20) Remove the bolts which hold intake manifold onto the cylinder heads.

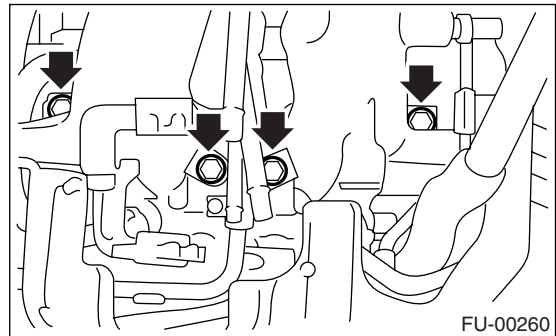

21) Remove the intake manifold.

B: INSTALLATION

1) Install the intake manifold onto the cylinder heads.

NOTE:

Replace the gaskets with new ones.

Tightening torque:

25 N·m (2.5 kgf·m, 18.1 ft·lb)

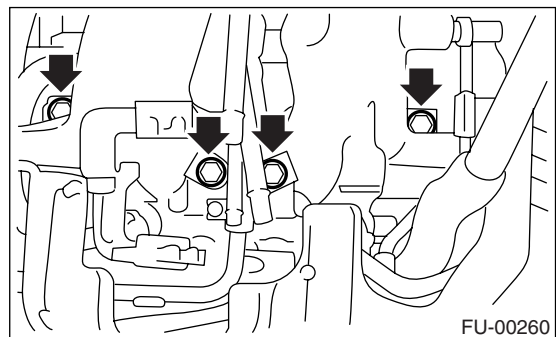

INTAKE MANIFOLD

FUEL INJECTION (FUEL SYSTEMS)

2) Connect the fuel hoses.

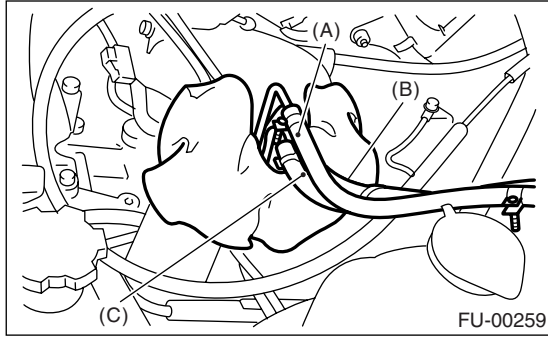

- (A) Fuel delivery hose
- (B) Return hose
- (C) Evaporation hose

3) Install the EGR pipe to intake manifold.

Tightening torque:

34 N·m (3.4 kgf-m, 24.6 ft-lb)

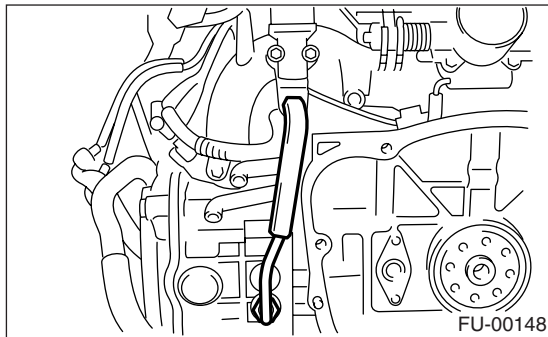

4) Connect the connector to the camshaft position sensor.

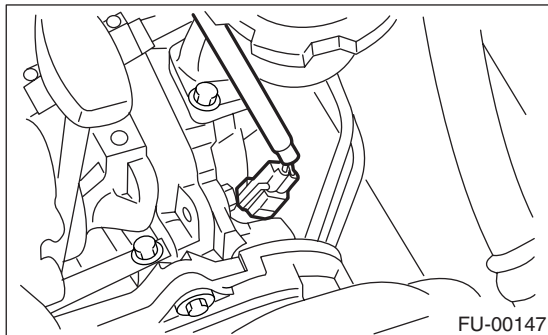

5) Connect the connector to the oil pressure switch.

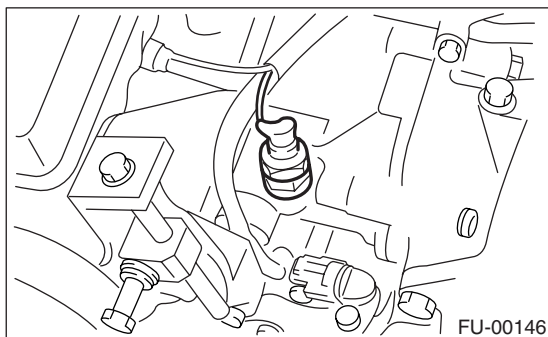

6) Connect the connector to the crankshaft position sensor.

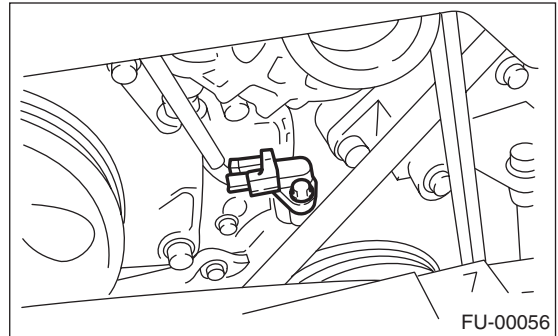

7) Connect the knock sensor connector.

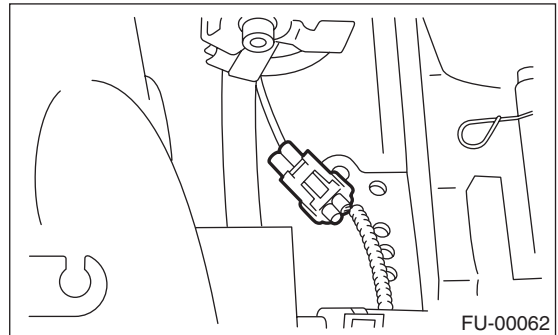

8) Connect the connectors to the engine coolant temperature sensor.

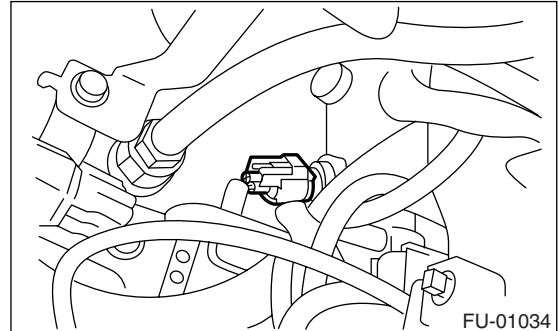

9) Install the air cleaner case stay RH and engine harness bracket, and connect the engine harness connectors to the bulkhead connectors.

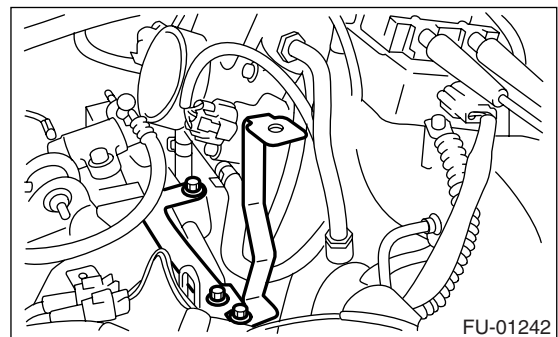

INTAKE MANIFOLD

FUEL INJECTION (FUEL SYSTEMS)

10) Connect the brake booster hose.

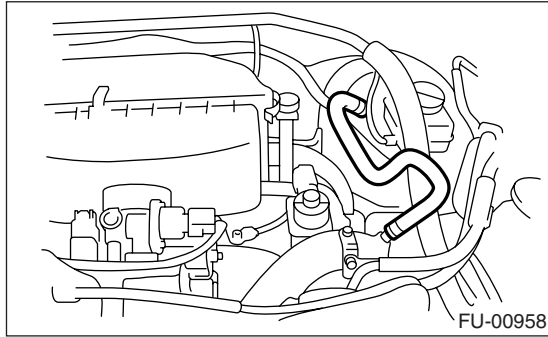

11) Connect the engine coolant hose (A) to the throttle body.

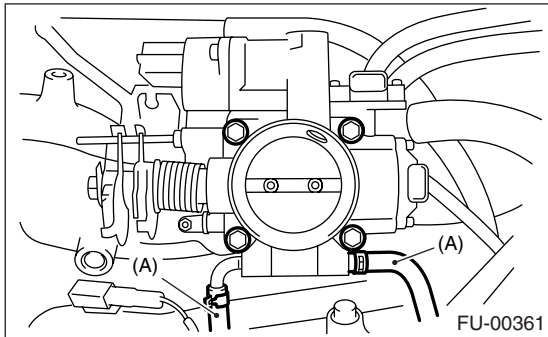

12) Connect the PCV hose to the intake manifold.

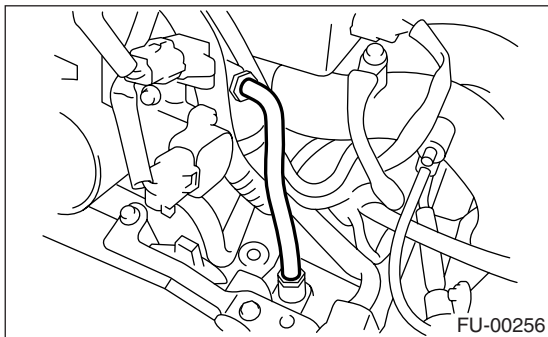

13) Connect the spark plug cords to the spark plugs.

14) Install the power steering pump and reservoir tank to bracket.

(1) Install the reservoir tank to bracket.

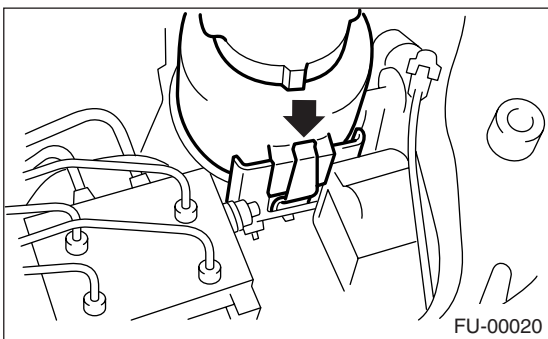

(2) Connect the connector to the power steering pump switch.

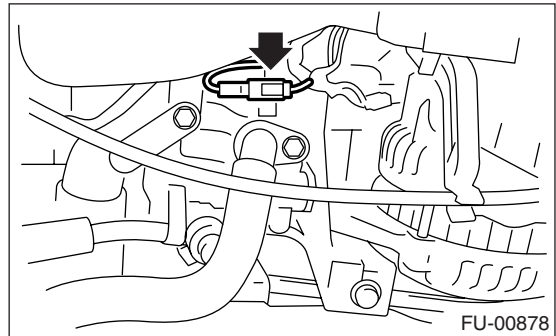

(3) Install the power steering pump bracket.

Tightening torque:
22 N·m (2.2 kgf-m, 15.9 ft-lb)

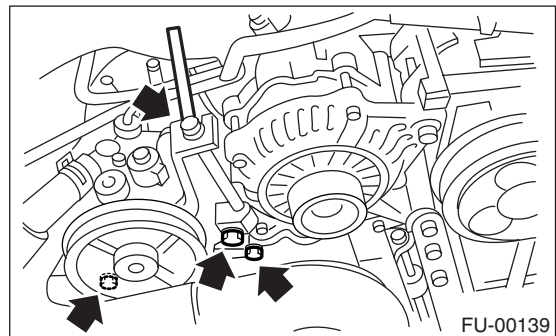

(4) Install the power steering pipes onto the right side intake manifold protector.

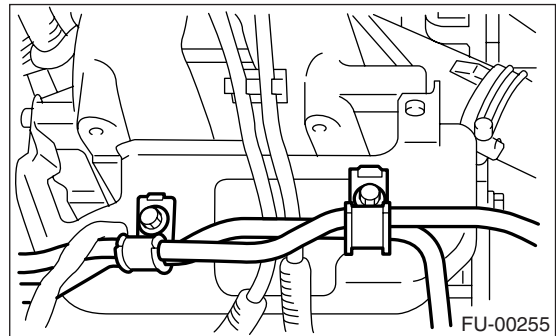

(5) Install the front side V-belt. <Ref. to ME(H4SO)-42, INSTALLATION, V-belt.>

INTAKE MANIFOLD

FUEL INJECTION (FUEL SYSTEMS)

(6) Install the resonator chamber.

Tightening torque:

33 N·m (3.4 kgf·m, 24.6 ft·lb)

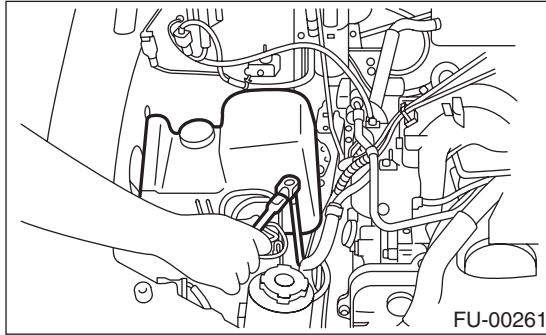

15) Connect the accelerator cable (A).

16) Connect the cruise control cable (B). (With cruise control models)

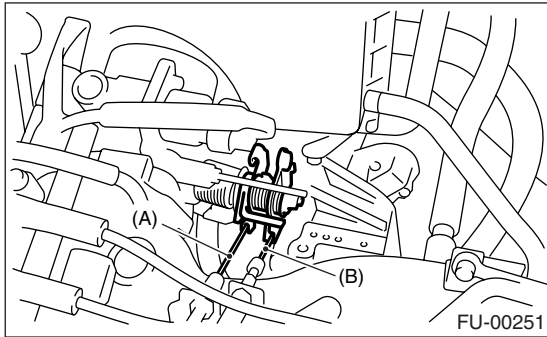

17) Install the air intake duct and air cleaner case. <Ref. to IN(H4SO)-7, INSTALLATION, Air Intake Duct.> <Ref. to IN(H4SO)-6, INSTALLATION, Air Cleaner Case.>

18) Connect the connector to the fuel pump relay.

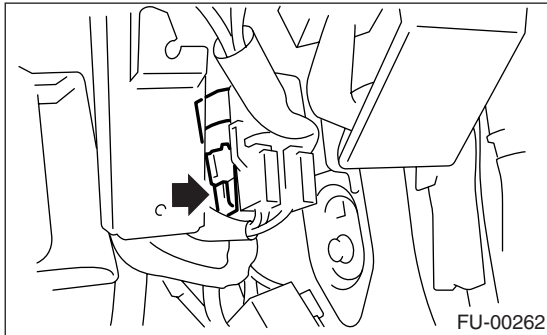

19) Connect the battery ground cable to battery.

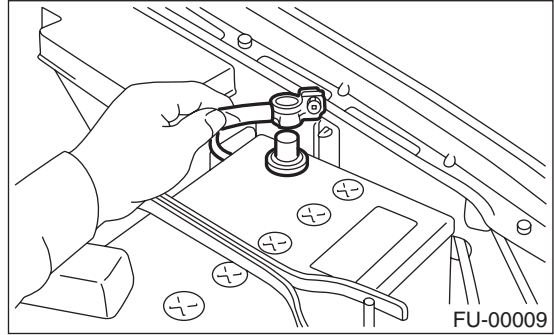

C: DISASSEMBLY

1) Disconnect the engine ground terminal from the intake manifold.

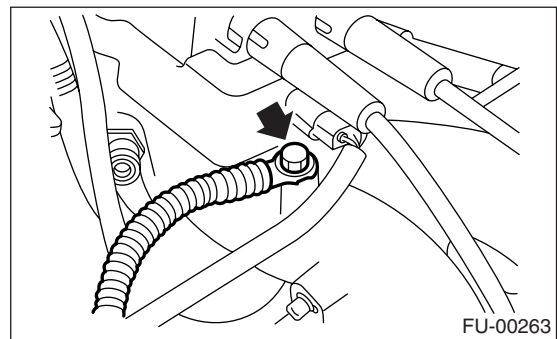

2) Remove the ignition coil and ignitor assembly. <Ref. to IG(H4SO)-8, REMOVAL, Ignition Coil and Ignitor Assembly.>

3) Remove the throttle body. <Ref. to FU(H4SO)-13, REMOVAL, Throttle Body.>

4) Remove the EGR valve. <Ref. to FU(H4SO)-34, REMOVAL, EGR Valve.>

5) Remove the air assist injector solenoid valve from the intake manifold. <Ref. to FU(H4SO)-35, REMOVAL, Air Assist Injector Solenoid Valve.>

6) Disconnect the pressure regulator vacuum hose from the intake manifold.

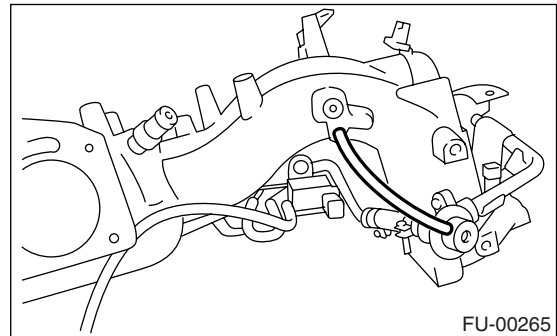

INTAKE MANIFOLD

FUEL INJECTION (FUEL SYSTEMS)

7) Remove the fuel pipe protector LH.

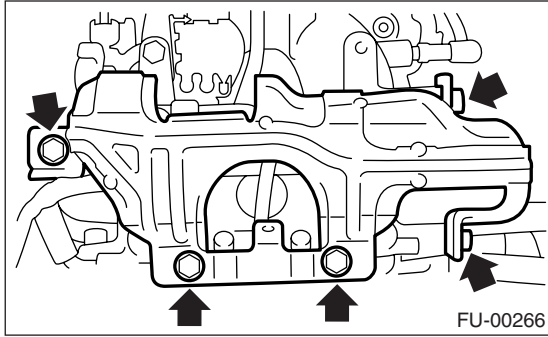

8) Remove the fuel pipe protector RH.

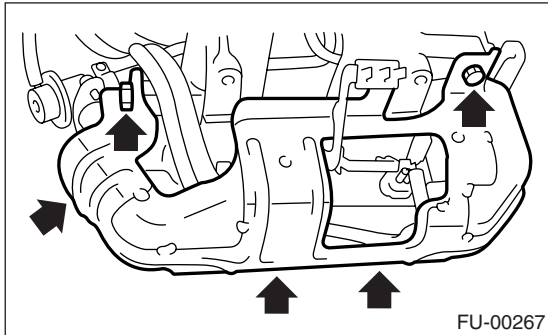

9) Disconnect the connectors from the fuel injectors.

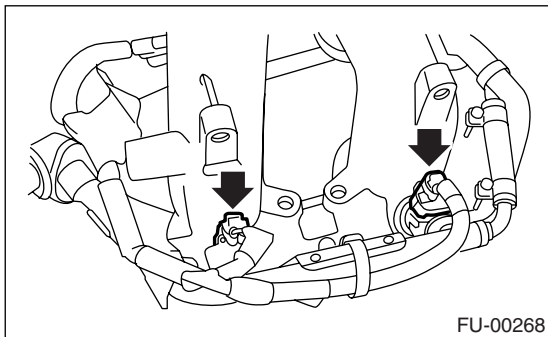

10) Remove the purge control solenoid valve.
<Ref. to IG(H4SO)-8, REMOVAL, Ignition Coil and Ignitor Assembly.>

11) Remove the harness bands (A) and harness bracket which hold engine harness onto the intake manifold.

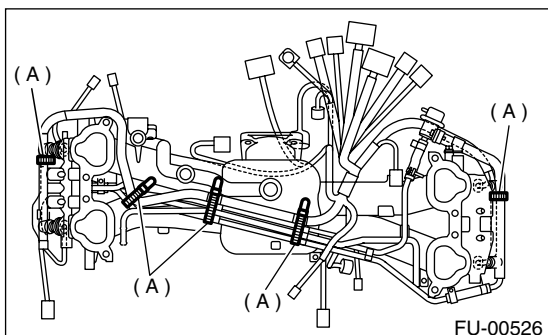

12) Remove the engine harness from the intake manifold.

13) Remove the bolt which installs injector pipe on the intake manifold as shown in figure.

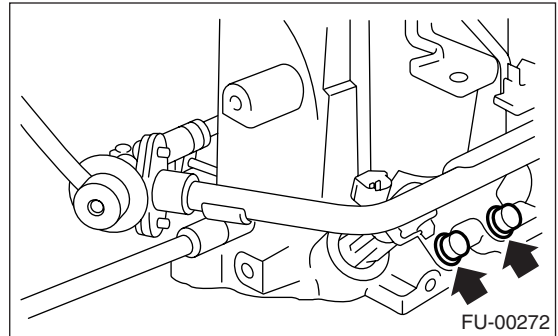

14) Remove the bolt which installs injector pipe on the intake manifold.

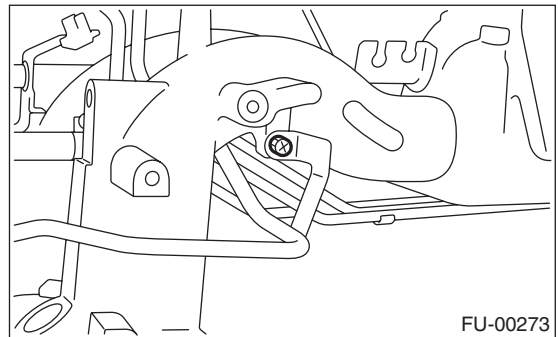

15) Remove the bolts which hold fuel pipes on the left side intake manifold.

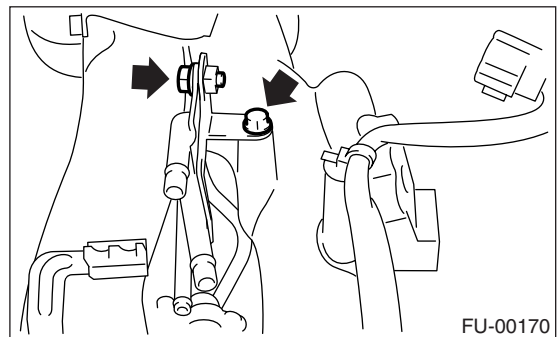

16) Remove the fuel injectors.

(1) Remove the fuel injector securing clip.

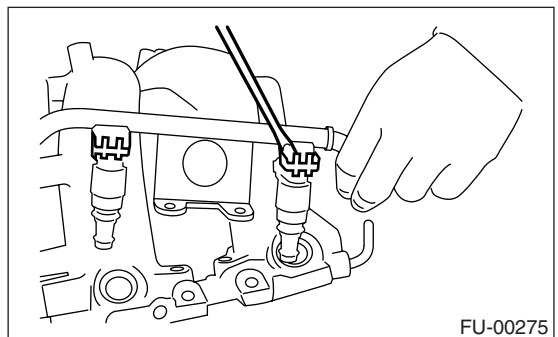

INTAKE MANIFOLD

FUEL INJECTION (FUEL SYSTEMS)

- (2) Remove the fuel injector while lifting up the fuel injector pipe.

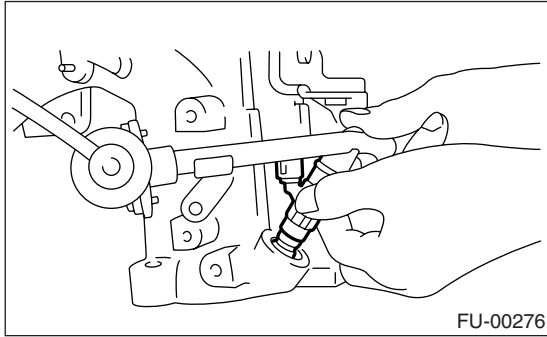

- 17) Disconnect the air by-pass hoses from the intake manifold.

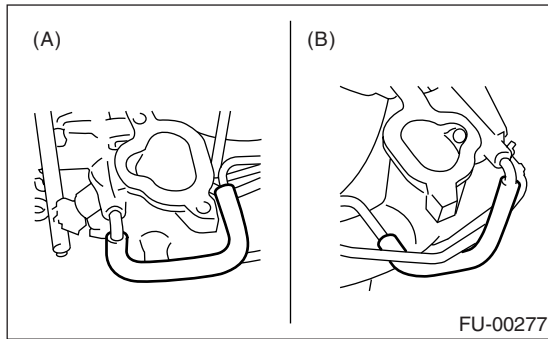

- (A) LH side
(B) RH side

- 18) Loosen the clamp which holds the front left side fuel hose to the injector pipe and remove the pipe.

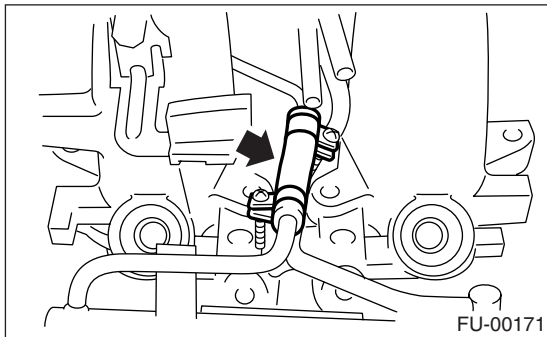

- 19) Loosen the clamp which holds the front right side fuel hose to the injector pipe and remove the pipe.

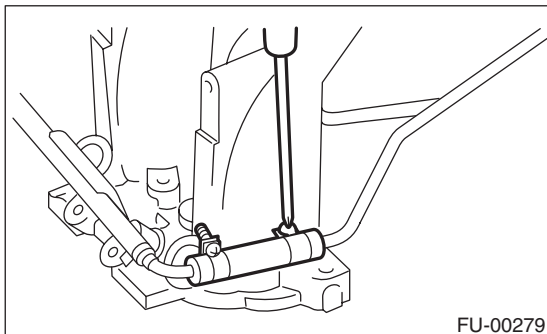

- 20) Remove the fuel injector pipe.
21) Remove the bolt which installs the fuel pipes on the intake manifold.

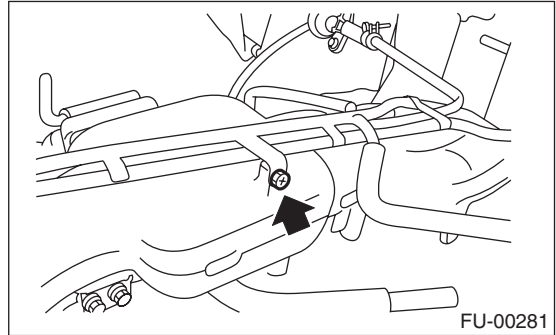

- 22) Remove the fuel pipe assembly and pressure regulator, from the intake manifold.

D: ASSEMBLY

- 1) Install the fuel pipe assembly and pressure regulator, etc. to the intake manifold.
2) Tighten the bolt which installs the fuel pipes on the intake manifold.

Tightening torque:

5.0 N·m (0.51 kgf-m, 3.7 ft-lb)

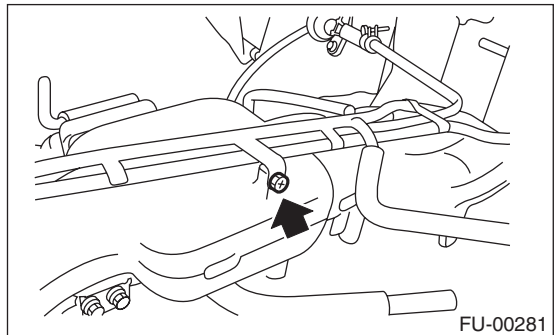

- 3) Connect the right side fuel hose to the injector pipe, and tighten the clamp screw.

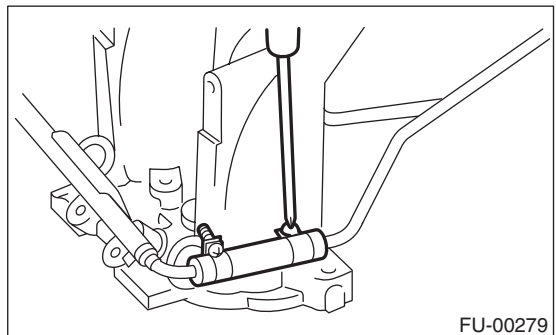

- 4) Install the fuel injector pipe.

INTAKE MANIFOLD

FUEL INJECTION (FUEL SYSTEMS)

5) Connect the left side fuel hose to the injector pipe, and tighten the clamp screw.

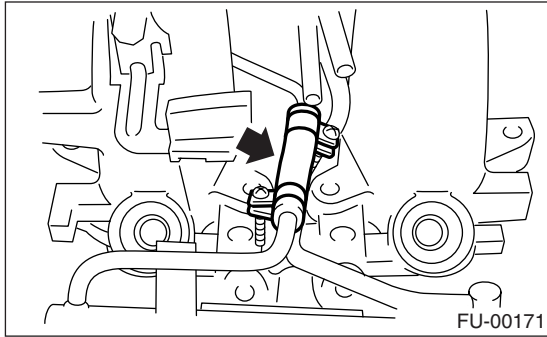

6) Connect the air assist hoses.

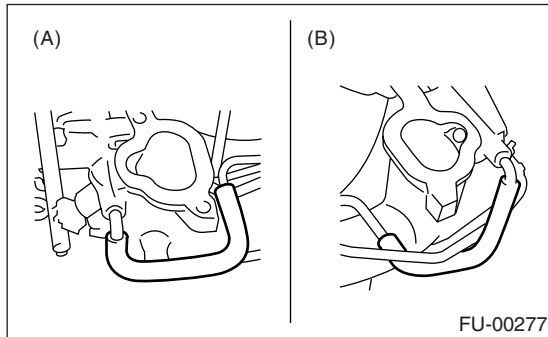

- (A) LH side
- (B) RH side

7) Install the fuel injectors.

NOTE:

Replace the O-rings with new ones.

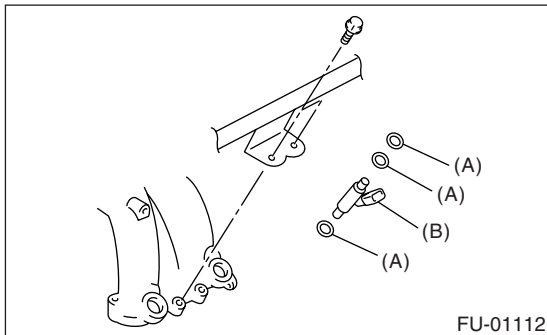

- (A) O-ring
- (B) Fuel injector

8) Install the fuel injector securing clip.

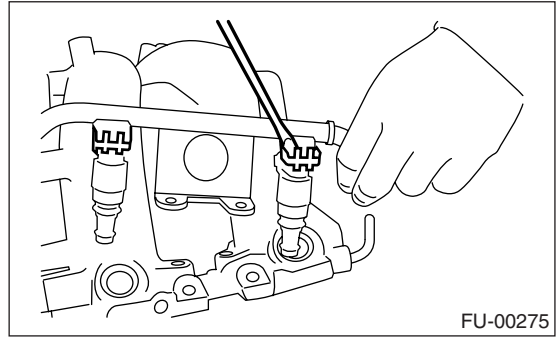

9) Tighten the bolt which installs the injector pipe on the intake manifold.

Tightening torque:

5.0 N·m (0.51 kgf·m, 3.7 ft·lb)

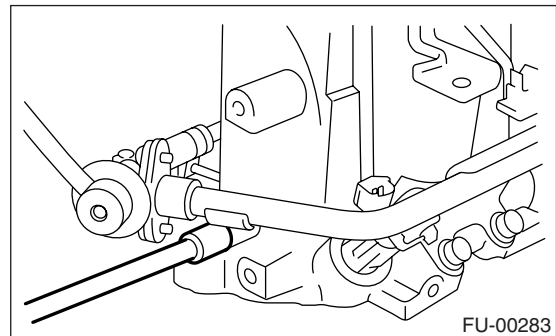

Tightening torque:

19 N·m (1.9 kgf·m, 13.7 ft·lb)

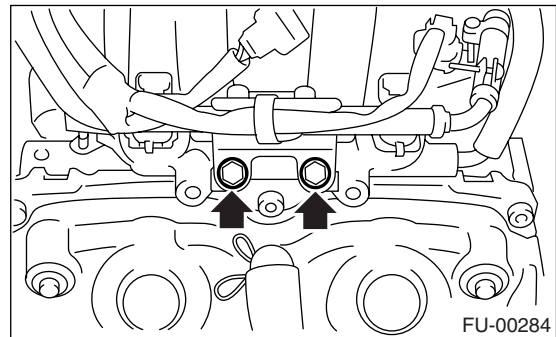

INTAKE MANIFOLD

FUEL INJECTION (FUEL SYSTEMS)

10) Tighten the bolts which install the fuel pipes on the left side intake manifold.

Tightening torque:

5.0 N·m (0.51 kgf-m, 3.7 ft-lb)

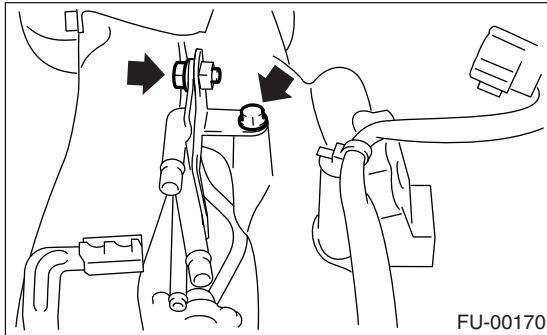

11) Tighten the bolt which install the injector pipe on the intake manifold.

Tightening torque:

5.0 N·m (0.51 kgf-m, 3.7 ft-lb)

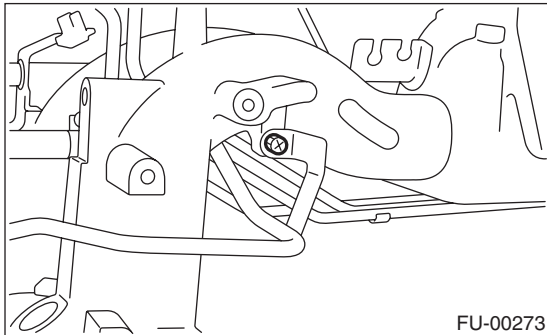

12) Install the purge control solenoid valve.

Tightening torque:

19 N·m (1.9 kgf-m, 13.7 ft-lb)

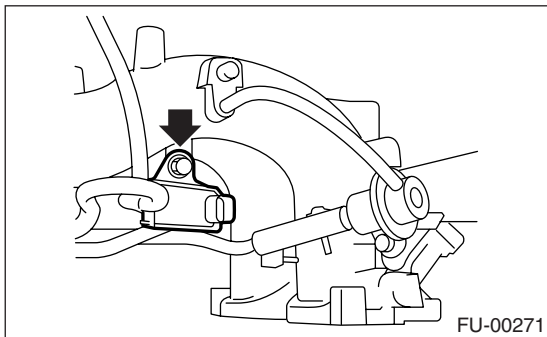

13) Connect the hoses to the purge control solenoid valve.

CAUTION:

Connect the evaporation hose as shown in the figure.

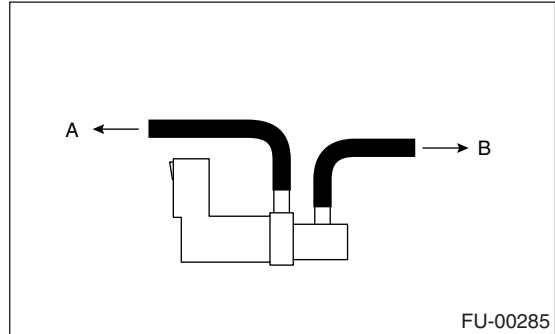

(A) To fuel pipe

(B) To intake manifold

14) Install the engine harness onto the intake manifold.

Tightening torque:

16 N·m (1.6 kgf-m, 11.8 ft-lb)

15) Connect the connectors to the fuel injectors and purge control solenoid valve.

16) Hold the engine harness by harness band (A) and harness bracket.

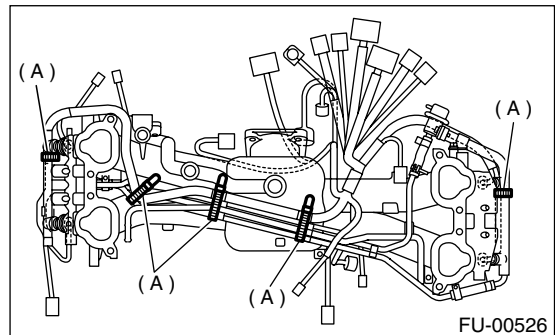

NOTE:

Do not use harness band on harnesses where they are supposed to be protected by the fuel pipe protector.

17) Install the fuel pipe protector RH.

Tightening torque:

19 N·m (1.9 kgf-m, 13.7 ft-lb)

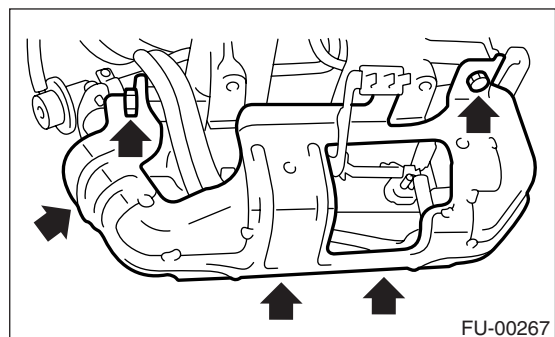

INTAKE MANIFOLD

FUEL INJECTION (FUEL SYSTEMS)

18) Install the fuel pipe protector LH.

Tightening torque:

19 N·m (1.9 kgf·m, 13.7 ft·lb)

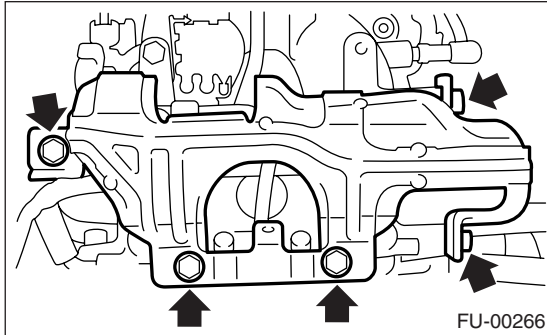

19) Connect the pressure regulator vacuum hose to the intake manifold.

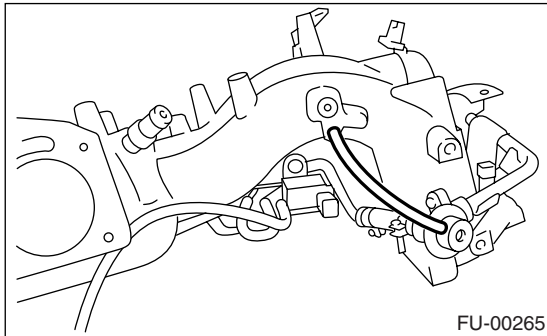

20) Install the air assist injector solenoid valve to the bracket. <Ref. to FU(H4SO)-35, INSTALLATION, Air Assist Injector Solenoid Valve.>

21) Install the EGR valve. <Ref. to FU(H4SO)-34, REMOVAL, EGR Valve.>

22) Install the throttle body to the intake manifold. <Ref. to FU(H4SO)-13, INSTALLATION, Throttle Body.>

23) Install the ignition coil & ignitor assembly.

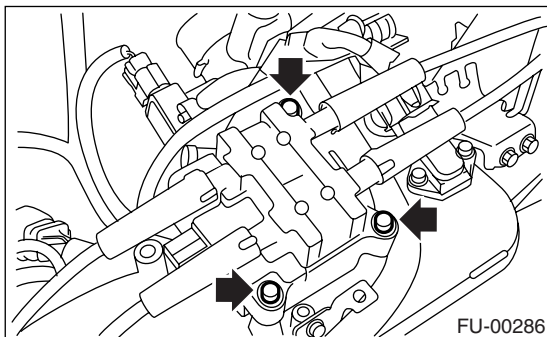

24) Connect the connector to the ignition coil and ignitor assembly.

25) Install the engine ground terminal to the intake manifold.

Tightening torque:

19 N·m (1.9 kgf·m, 13.7 ft·lb)

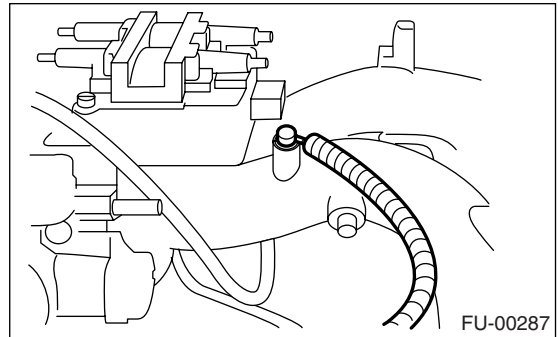

E: INSPECTION

Make sure the fuel pipe and fuel hoses are not cracked and that connections are tight.