

CRANK PULLEY

MECHANICAL

13.Crank Pulley

A: REMOVAL

1) Remove the V-belt. <Ref. to ME(H4SO)-42, REMOVAL, V-belt.>

2) Remove the crank pulley bolt. To lock the crankshaft, use ST.

ST 499977100 CRANK PULLEY WRENCH

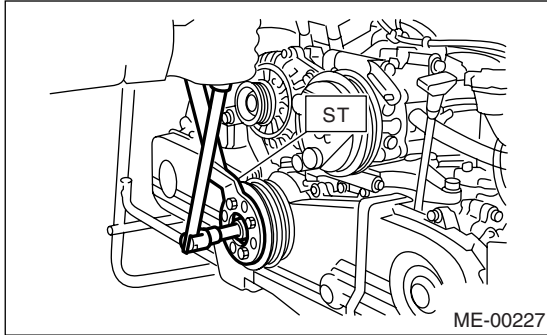

3) Remove the crank pulley.

B: INSTALLATION

1) Install the crank pulley.

2) Install the pulley bolt.

To lock the crankshaft, use ST.

ST 499977100 CRANK PULLEY WRENCH

(1) Clean the crank pulley thread using an air gun.

(2) Apply engine oil to the crank pulley bolt seat and thread.

(3) Tighten the bolts temporarily with tightening torque of 44 N·m (4.5 kgf·m, 33 ft·lb).

(4) Tighten the crank pulley bolts.

Tightening torque:

177 N·m (18.0 kgf·m, 130.2 ft·lb)

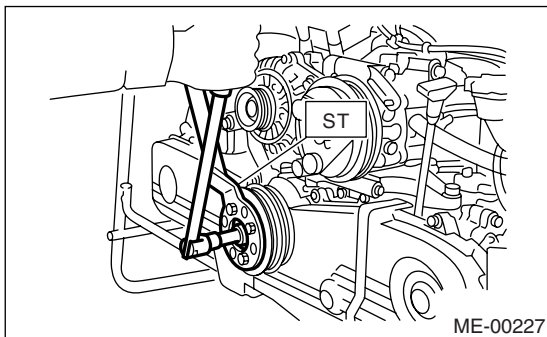

3) Confirm that the tightening angle of crank pulley bolt is 65 degrees or more. If the tightening angle of crank pulley bolt is less than 65 degrees, conduct the following procedures.

(1) Replace the crank pulley bolts and clean them.

Crank pulley bolt:

12369AA011

(2) Clean the crankshaft thread using an air gun.

(3) Apply engine oil to the crank pulley bolt seal and thread.

(4) Tighten the bolts temporarily with tightening torque of 44 N·m (4.5 kgf·m, 33 ft·lb).

(5) Tighten the crank pulley bolts keeping them in an angle between 65 degrees and 75 degrees.

NOTE:

Conduct the tightening procedures by confirming the turning angle of crank pulley bolt referring to the gauge indicated on timing belt cover.

4) Install the A/C belt tensioner.

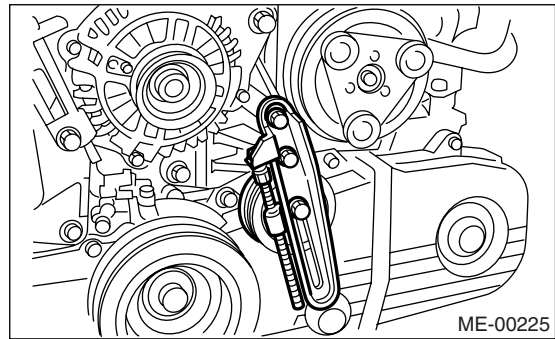

5) Install the V-belt. <Ref. to ME(H4SO)-42, INSTALLATION, V-belt.>

C: INSPECTION

1) Make sure the V-belt is not worn or otherwise damaged.

2) Check the tension of the belt. <Ref. to ME(H4SO)-43, INSPECTION, V-belt.>