

## 4. Front Ball Joint

### A: REMOVAL

- 1) Remove the wheel.
- 2) Pull out the cotter pin from ball stud, remove the castle nut, and extract the ball stud from transverse link.
- 3) Remove the bolt securing ball joint to housing.

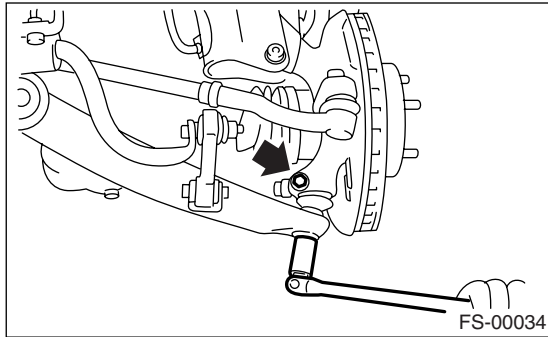

- 4) Extract the ball joint from housing.

### B: INSTALLATION

- 1) Install the ball joint onto housing.

**Tightening torque (Bolt):**  
**50 N·m (5.1 kgf·m, 37 ft·lb)**

**CAUTION:**  
**Do not apply grease to tapered portion of ball stud.**

- 2) Connect the ball joint to transverse link.

**Tightening torque (Castle nut):**  
**40 N·m (4.1 kgf·m, 30 ft·lb)**

- 3) Retighten the castle nut further within 60° until a slot in castle nut is aligned with the hole in ball stud end, then insert a new cotter pin and bend it around castle nut.
- 4) Install the front wheel.

### C: INSPECTION

- 1) Measure the play of ball joint by the following procedures. Replace with a new one when the play exceeds specified value.

- (1) With 686 N (70 kgf, 154 lb) loaded in direction shown in the figure, measure the dimension  $l_1$ .

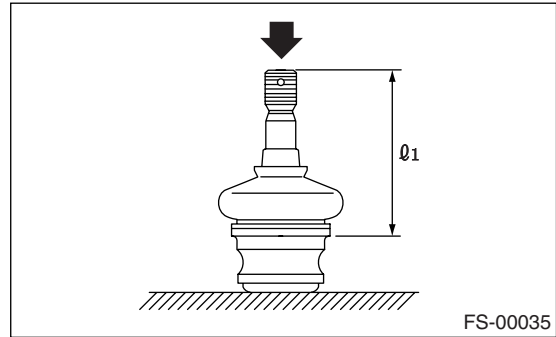

- (2) With 686 N (70 kgf, 154 lb) loaded in direction shown in the figure, measure the dimension  $l_2$ .

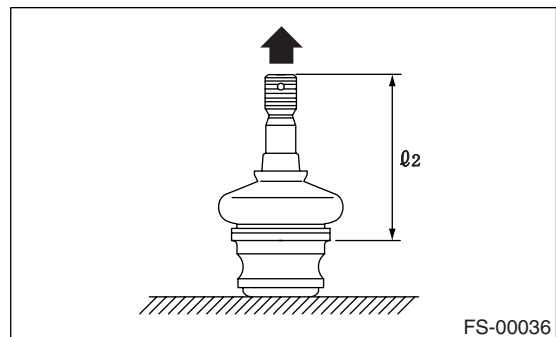

- (3) Calculate plays from the following formula.  
 $S = l_2 - l_1$
- (4) When plays are larger than the specified value, replace with a new one.

### FRONT BALL JOINT

**Specified play for replacement: S**  
**Less than 0.3 mm (0.012 in)**

- 2) When the play is smaller than specified value, visually inspect the dust cover.
- 3) The ball joint and cover that have been removed must be checked for wear, damage or cracks, and any defective part must be replaced.
- 4) If the dust cover is damaged, replace with a new ball joint.