

HEADLIGHT ASSEMBLY

LIGHTING SYSTEM

9. Headlight Assembly

A: REMOVAL

- 1) Disconnect the ground cable from battery.
- 2) Remove the air intake duct (when right side headlight is removed).
- 3) Remove the front grille and headlight side cover. <Ref. to EI-17, REMOVAL, Front Grille.> <Ref. to EI-19, REMOVAL, Front Bumper.>
- 4) Disconnect the headlight bulb connector.

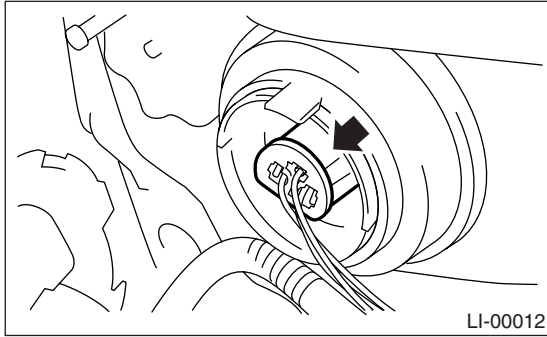

- 5) Remove the three bolts and disconnect connectors, and then detach the headlight assembly.

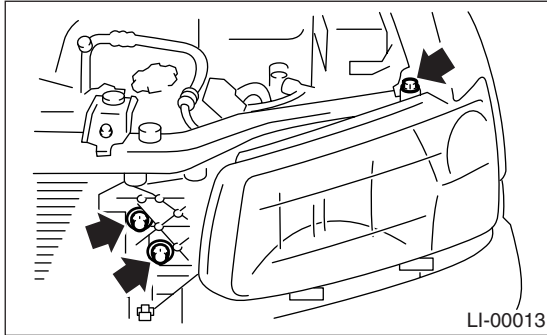

B: INSTALLATION

Install in the reverse order of removal.

C: ADJUSTMENT

1. HEADLIGHT AIMING

NOTE:

As this headlight is the "VISUAL AIMING TYPE", it is possible to adjust aiming only in the vertical direction. It cannot be adjusted in the horizontal direction.

CAUTION:

Turn off the light before adjusting headlight aiming. If the light is necessary to check aiming, do not turn on for more than two minutes.

NOTE:

Before checking the headlight aiming, be sure of the following:

- The area around the headlight has not sustained any accident, damage or other type of deformation.
- Vehicle is parked on level ground.
- The inflation pressure of tires is correct.
- Vehicle's gas tank is fully charged.
- Bounce the vehicle several times to normalize the suspension.
- Make certain that someone is seated in the driver's seat.

1) Place a cloth over the headlight that does not require aiming adjustment.

2) Turn the headlight on and then adjust the low beam pattern to the following positions on the screen.

CAUTION:

Do not perform lateral headlight aiming adjustment.

NOTE:

Adjust the headlight aiming by turning the adjusting screw (A).

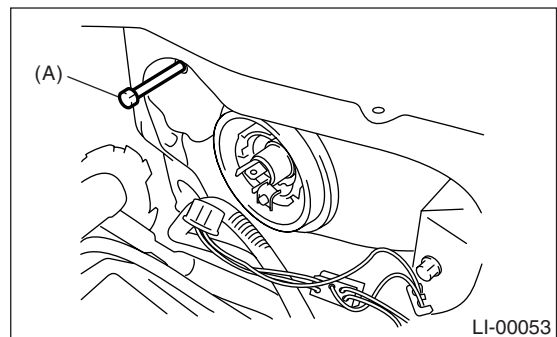

HEADLIGHT ASSEMBLY

LIGHTING SYSTEM

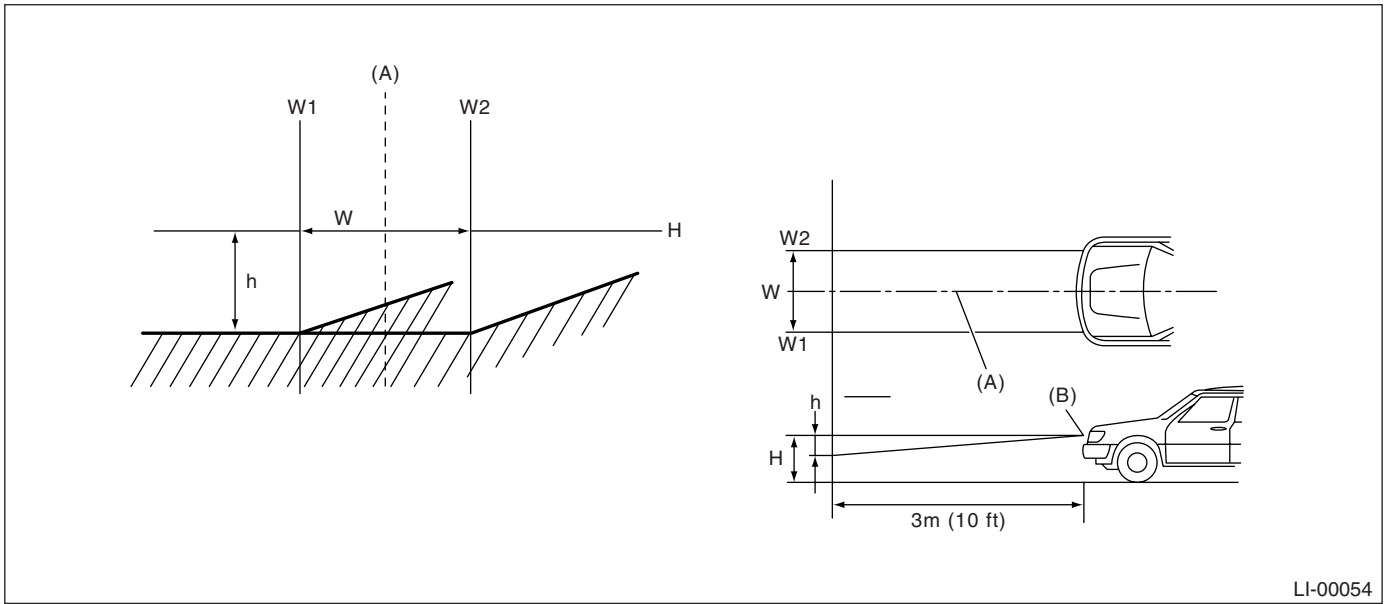

LI-00054

(A) Vehicle center

(B) Bulb center

W mm (in)	H mm (in)	h mm (in) at 3 m (10 ft)
1,140 (44.88)	733 (28.9)	21 (0.83)