

2. Headlight and Tail Light System

A: WIRING DIAGRAM

1. HEADLIGHT

<Ref. to WI-115, SCHEMATIC, Headlight System.>

2. CLEARANCE LIGHT AND ILLUMINATION LIGHT

<Ref. to WI-111, SCHEMATIC, Clearance Light and Illumination Light System.>

B: INSPECTION

1. HEADLIGHT SWITCH

<Ref. to LI-9, INSPECTION, Combination Switch (Light).>

2. HEADLIGHT RELAY

Measure the headlight relay resistance between terminals when connecting terminal No. 4 to battery positive terminal and terminal No. 3 to battery ground terminal.

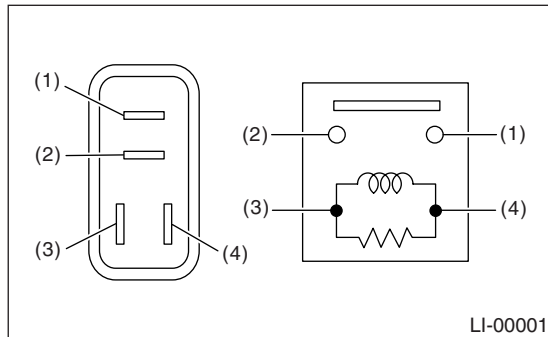

Current	Terminal No.	Standard
Flow	1 and 2	Less than 1 Ω
No flow		More than 1 MΩ

3. TAIL AND ILLUMINATION RELAY

Measure the tail and illumination relay resistance between terminals when connecting terminal No. 4 to battery positive terminal and terminal No. 3 to battery ground terminal.

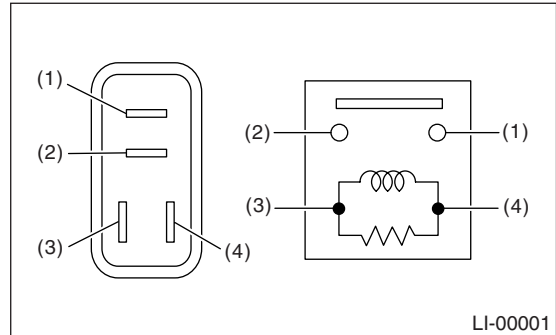

Current	Terminal No.	Standard
Flow	1 and 2	Less than 1 Ω
No flow		More than 1 MΩ