

24. Luggage Room Light

A: REMOVAL

- 1) Disconnect the ground cable from battery.
- 2) Remove the lens (A) and luggage room light mounting screws (B).

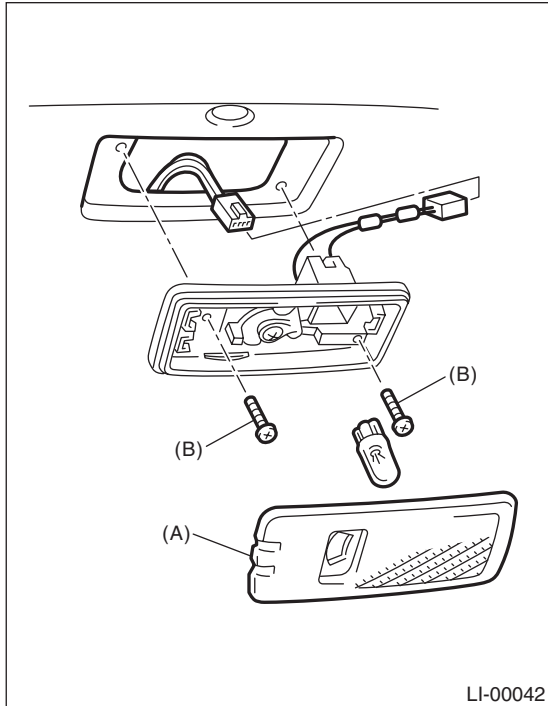

- 3) Disconnect the harness connectors and remove the luggage room light.

B: INSTALLATION

Install in the reverse order of removal.

C: INSPECTION

1. LUGGAGE ROOM LIGHT BULB

- 1) Visually check the bulb for blow out.
- 2) Check the bulb specification. <Ref. to LI-2, SPECIFICATIONS, General Description.>
- 3) If NG, replace the bulb with a new one.

2. LUGGAGE ROOM LIGHT SWITCH

Measure the luggage room light switch resistance.

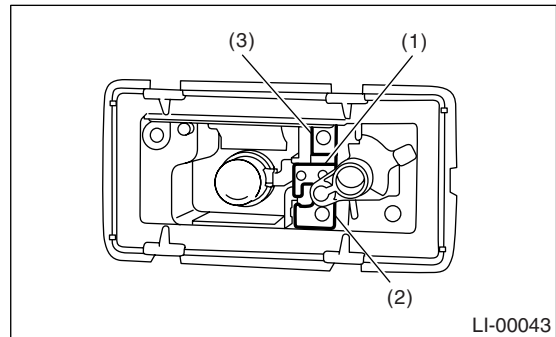

Switch position	Terminal No.	Standard
OFF	—	More than 1 MΩ
ON	1 and 3	1.5 ± 0.5 Ω
DOOR	1 and 2	1.5 ± 0.5 Ω