

SECURITY AND LOCKS

SL

	Page
1. General Description	2
2. Door Lock Control System	9
3. Keyless Entry System	14
4. Front Inner Remote	22
5. Front Outer Handle	23
6. Front Door Latch Assembly.....	24
7. Front Door Lock Actuator	25
8. Rear Inner Remote.....	26
9. Rear Outer Handle	27
10. Rear Door Latch Assembly	28
11. Rear Door Lock Actuator.....	29
12. Rear Gate Outer Handle	30
13. Rear Gate Latch Assembly	31
14. Rear Gate Latch Lock Actuator.....	32
15. Front Hood Lock Assembly	33
16. Remote Openers	34
17. Ignition Key Lock.....	35
18. Key Lock Cylinder	36
19. Immobilizer Control Module	37
20. Immobilizer Antenna	38
21. Keyless Entry Control Module.....	39
22. Double Lock Module	40
23. Keyless Transmitter	41

GENERAL DESCRIPTION

SECURITY AND LOCKS

1. General Description

A: COMPONENT

1. DOOR LOCK ASSEMBLY

Without double lock:

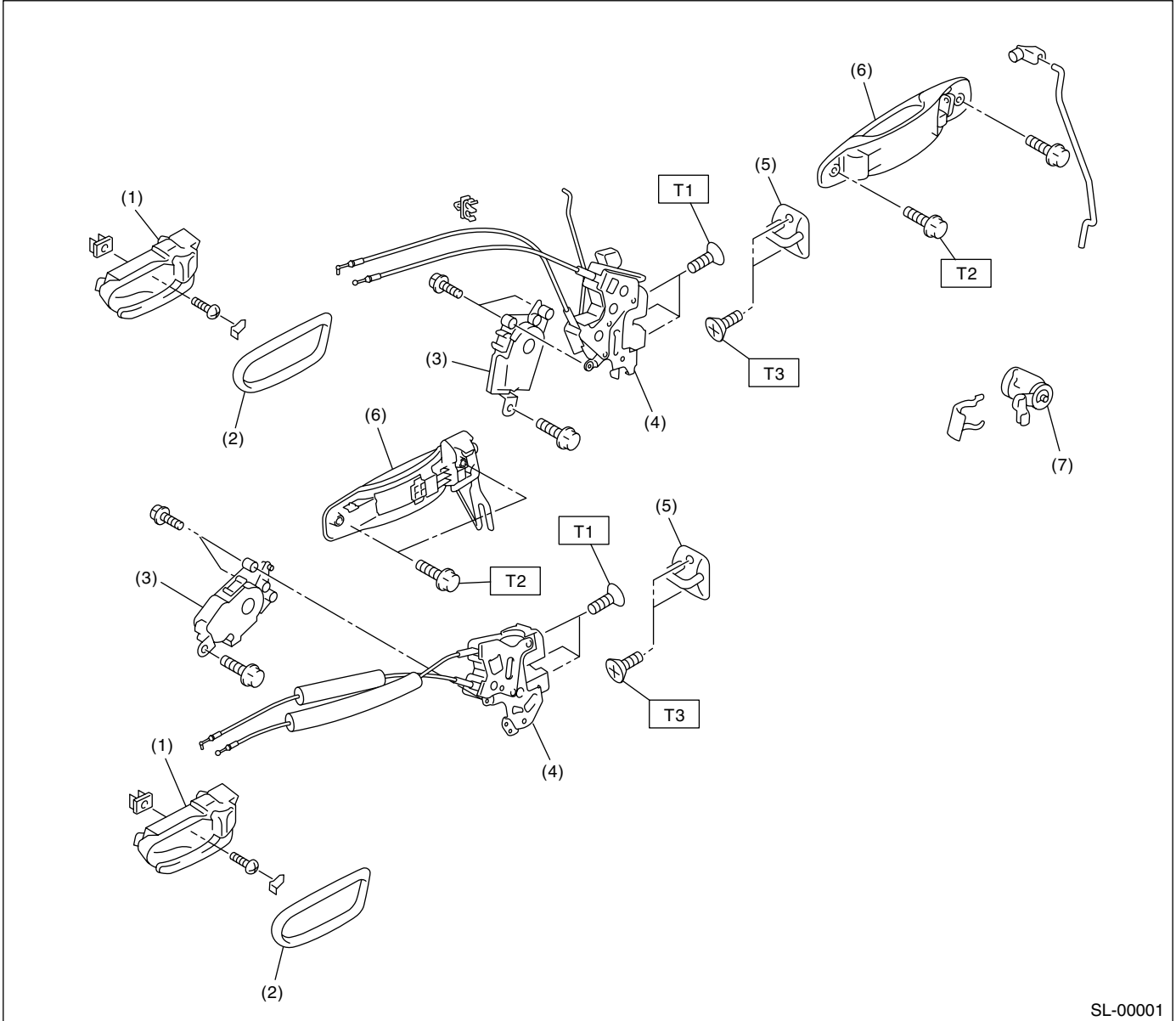

SL-00001

- | | |
|-----------------------------|-----------------------|
| (1) Inner remote ASSY | (5) Striker |
| (2) Inner remote cover | (6) Door outer handle |
| (3) Auto-door lock actuator | (7) Key cylinder |
| (4) Door latch | |

Tightening torque: N-m (kgf-m, ft-lb)

T1: 6.4 (0.65, 4.7)

T2: 7.4 (0.75, 5.5)

T3: 17.6 (1.8, 13.0)

GENERAL DESCRIPTION

With double lock:

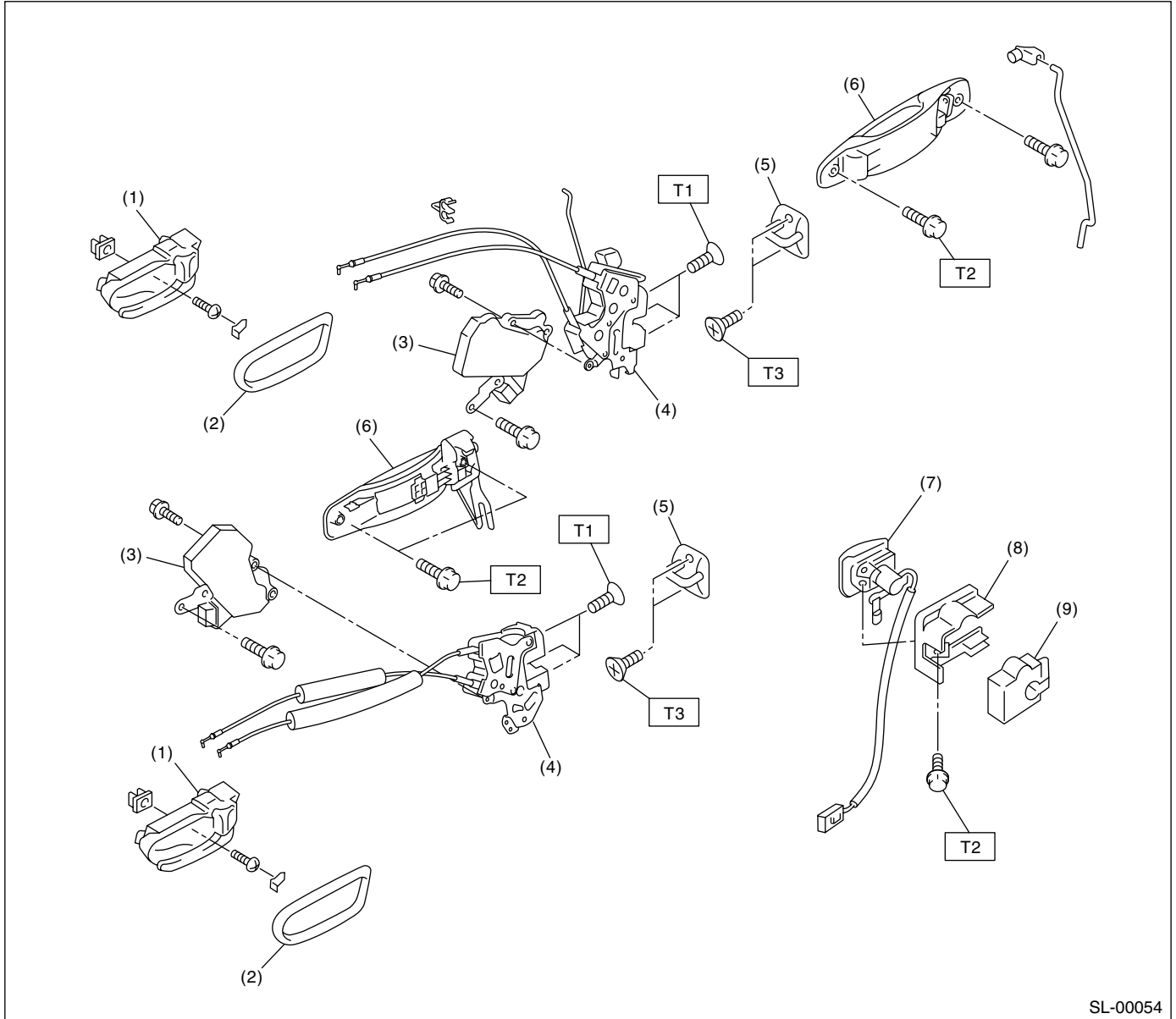

- | | |
|-----------------------------|---------------------------------|
| (1) Inner remote ASSY | (6) Door outer handle |
| (2) Inner remote cover | (7) Key cylinder (switch) |
| (3) Auto-door lock actuator | (8) Key cylinder retainer |
| (4) Door latch | (9) Key cylinder retainer cover |
| (5) Striker | |

Tightening torque: N-m (kgf-m, ft-lb)
T1: 6.4 (0.65, 4.7)
T2: 7.4 (0.75, 5.5)
T3: 17.6 (1.8, 13.0)

GENERAL DESCRIPTION

SECURITY AND LOCKS

2. REAR GATE LOCK

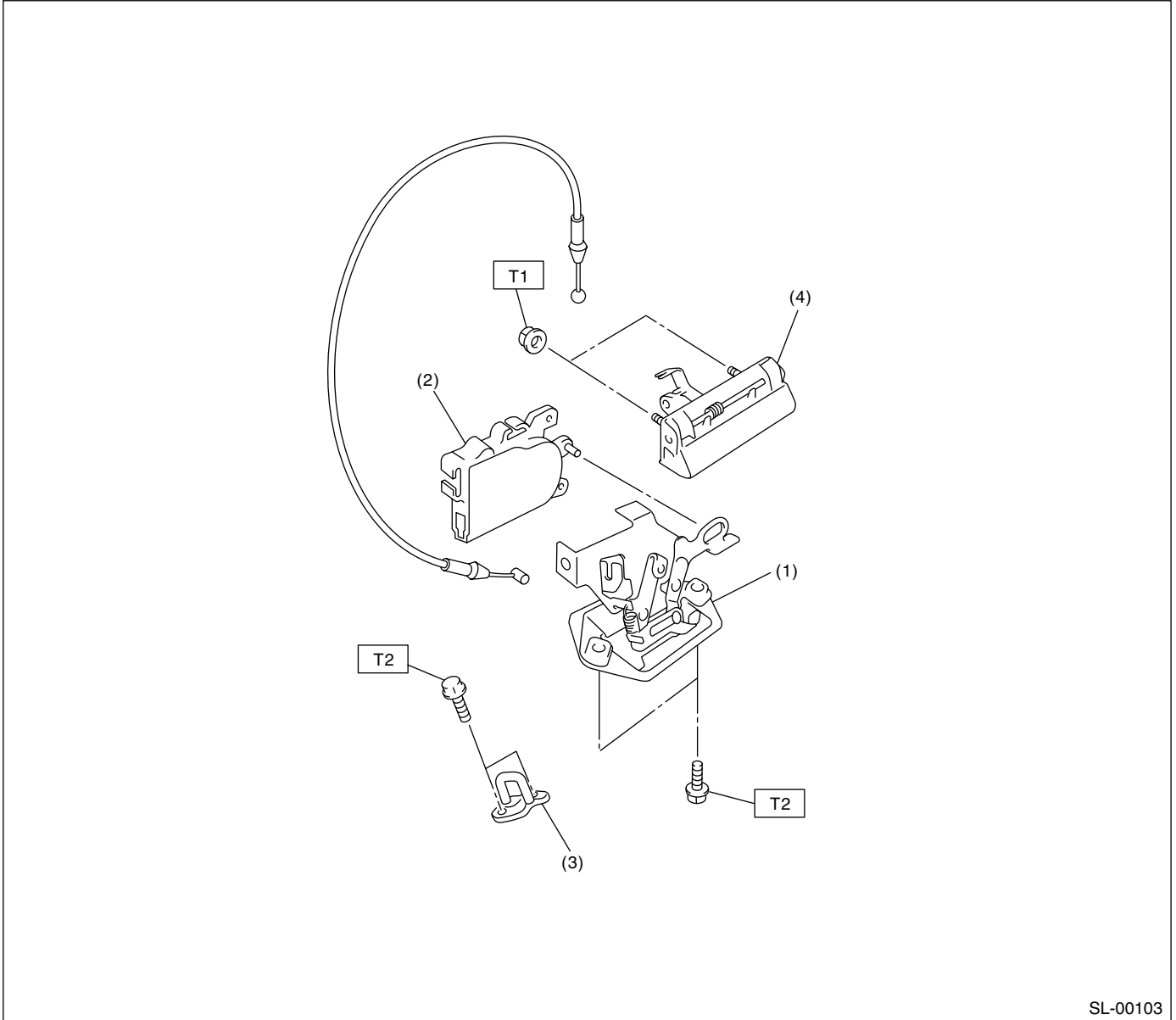

- (1) Rear gate latch ASSY
- (2) Rear gate actuator
- (3) Striker

- (4) Rear gate outer handle

Tightening torque: N-m (kgf-m, ft-lb)

T1: 7.5 (0.75, 5.4)

T2: 25 (2.5, 18.4)

3. HOOD LOCK AND REMOTE OPENERS

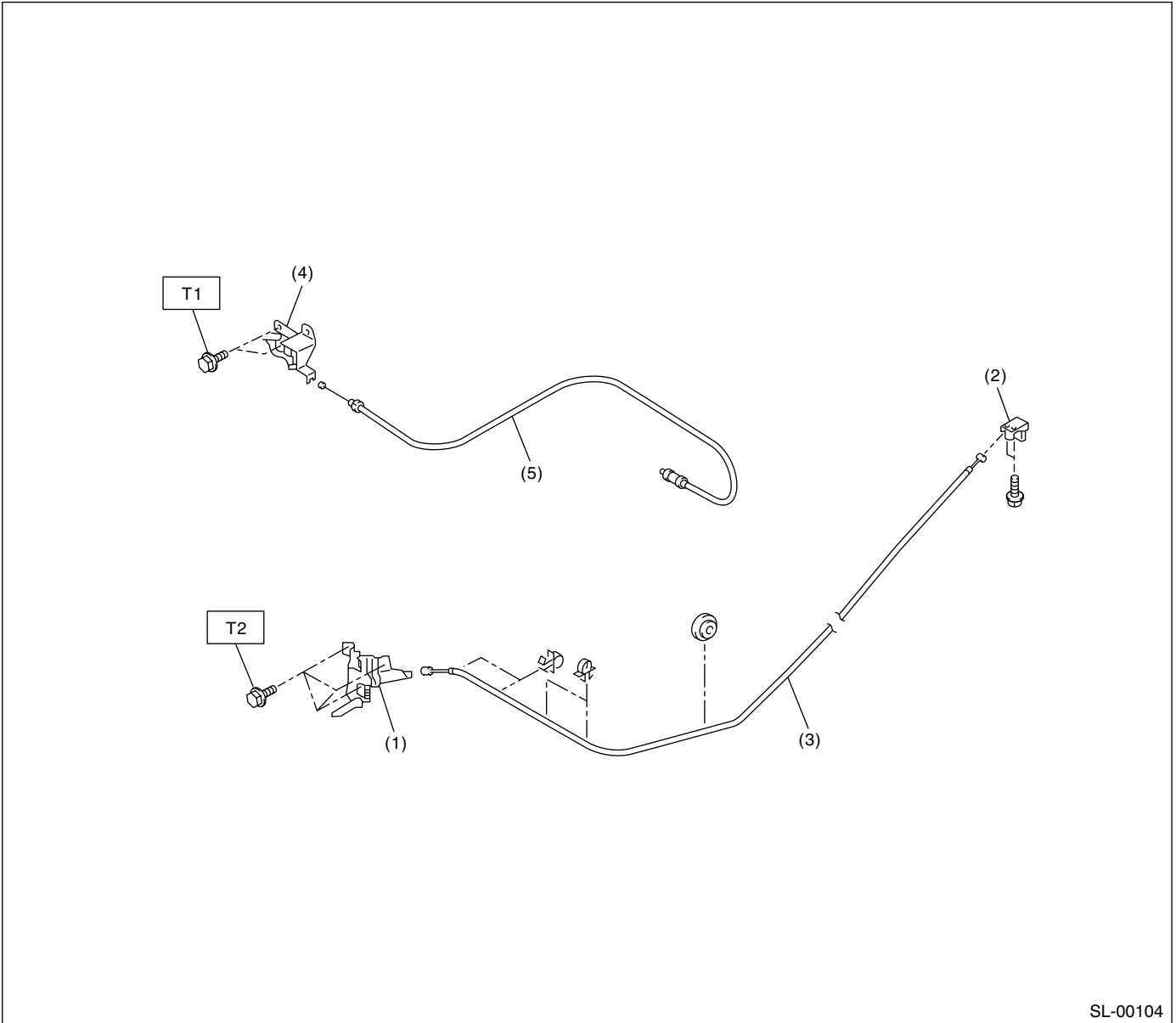

SL-00104

- | | |
|---------------------|--------------------------|
| (1) Hood lock ASSY | (4) Pull handle ASSY |
| (2) Lever ASSY | (5) Fuel flap cable ASSY |
| (3) Hood cable ASSY | |

Tightening torque: N-m (kgf-m, ft-lb)

T1: 7.4 (0.75, 5.4)

T2: 33 (3.4, 24.6)

GENERAL DESCRIPTION

SECURITY AND LOCKS

4. IMMOBILIZER SYSTEM

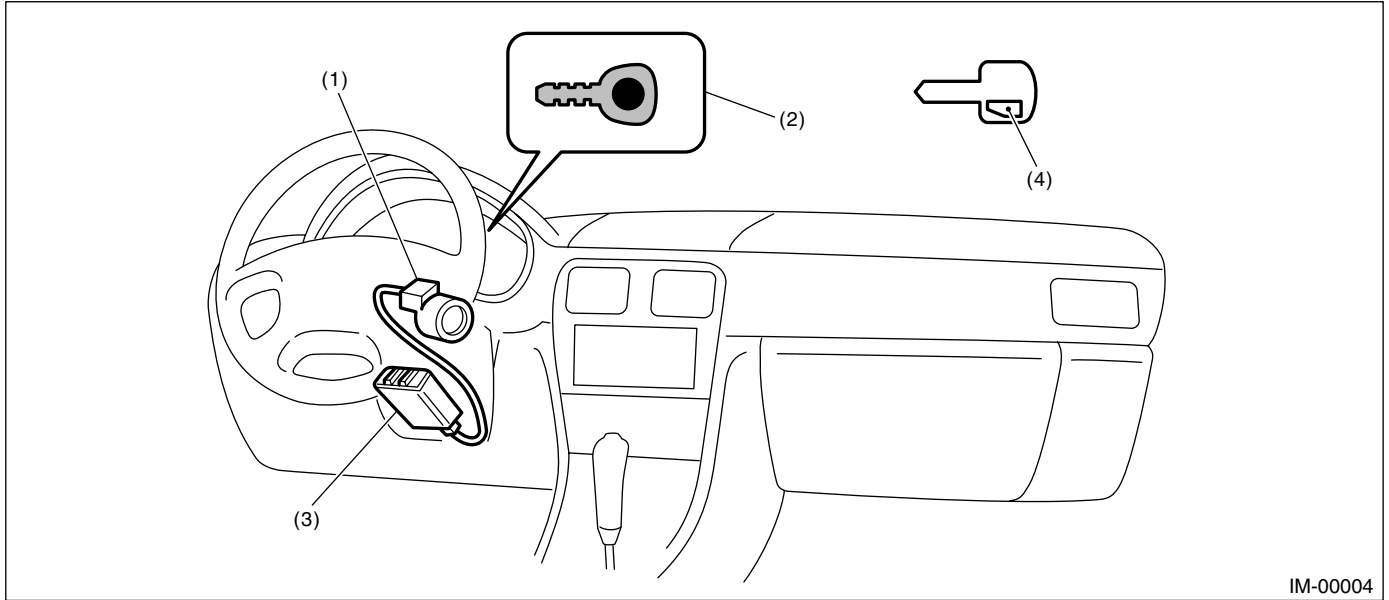

- | | |
|--|--|
| (1) Antenna | (3) Immobilizer control module (IMM ECM) |
| (2) Immobilizer indicator light (LED bulb) | (4) Transponder |

NOTE:
IMM ECM location for RHD model is symmetrically opposite.

5. KEYLESS ENTRY SYSTEM

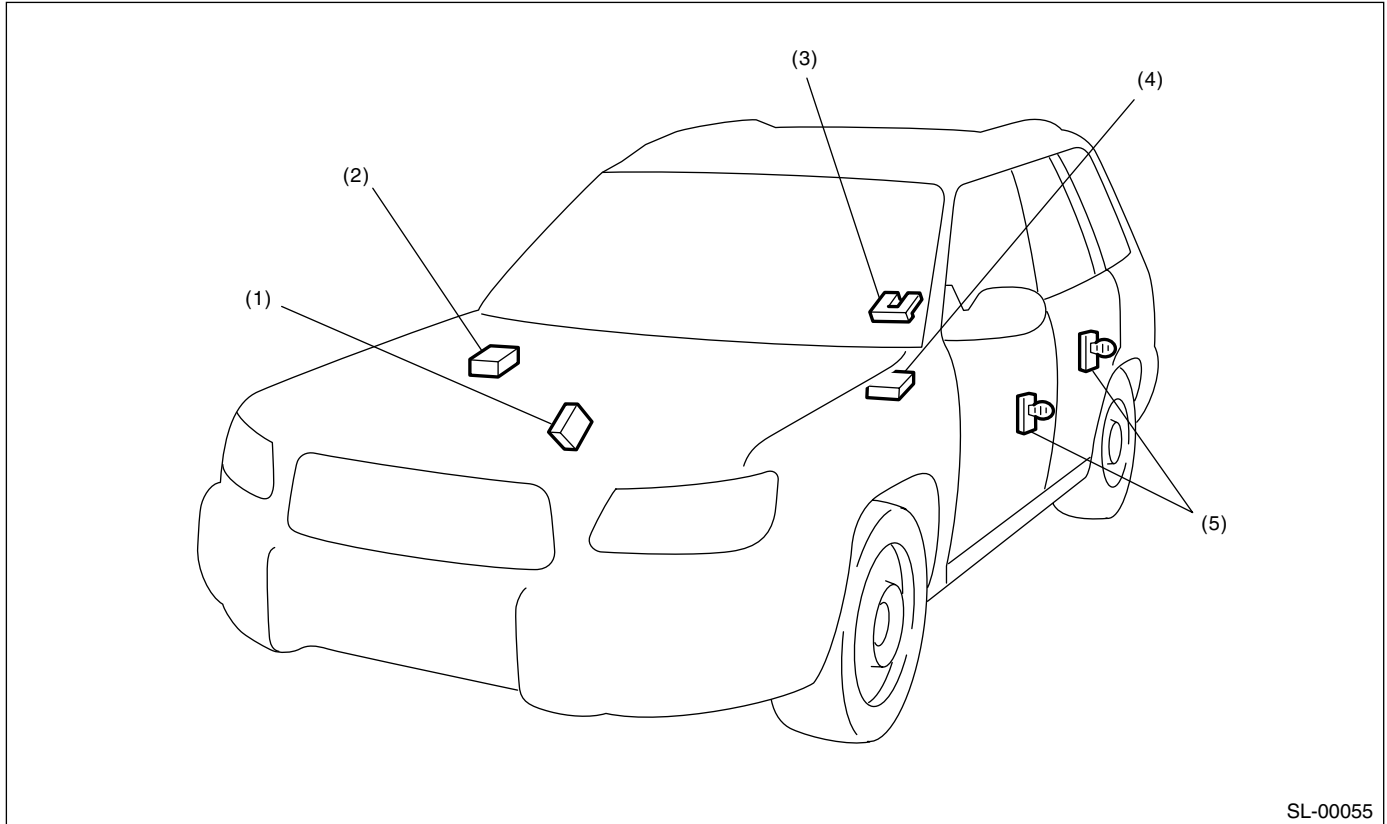

SL-00055

- | | | |
|--|--|-----------------|
| (1) Double lock module (with double lock) | (3) Rear gate latch switch | (5) Door switch |
| (2) Keyless entry control module (LHD model) | (4) Keyless entry control module (RHD model) | |

B: CAUTION

- Before disassembling or reassembling parts, always disconnect the ground cable from battery. When repairing radio, control module, etc. which are provided with memory functions, record the memory contents before disconnecting the ground cable from battery. Otherwise, these contents are cancelled upon disconnection.
- Reassemble parts in the reverse order of disassembly procedure unless otherwise indicated.
- Adjust parts to specifications contained in this manual if so designated.
- Connect the connectors and hoses securely during reassembly.
- After reassembly, ensure all functional parts operate smoothly.
- Airbag system wiring harness is routed near the electrical parts and switch.
- All airbag system wiring harness and connectors are colored yellow. Do not use electrical test equipment on these circuits.

- Be careful not to damage the airbag system wiring harness when servicing the ignition key cylinder.

GENERAL DESCRIPTION

SECURITY AND LOCKS

C: PREPARATION TOOL

1. SPECIAL TOOLS

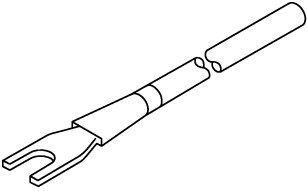
ILLUSTRATION	TOOL NUMBER	DESCRIPTION	REMARKS
 ST-925580000	925580000	PULLER	Used for removing trim clip.

2. GENERAL TOOLS

TOOL NAME	REMARKS
Circuit Tester	Used for measuring resistance and voltage.
Drill	Used for replacing ignition key lock.

2. Door Lock Control System

A: SCHEMATIC

1. DOOR LOCK CONTROL

<Ref. to WI-118, SCHEMATIC, Door Lock System.>

B: INSPECTION

1. SYMPTOM CHART

Symptom	Repair order	Reference
The door lock control system does not operate.	1. Check the fuse.	<Ref. to SL-9, CHECK FUSE, INSPECTION, Door Lock Control System.>
	2. Check the power supply and ground circuit for keyless entry control unit (without double lock) or double lock module (with double lock).	<Ref. to SL-10, CHECK POWER SUPPLY AND GROUND CIRCUIT, INSPECTION, Door Lock Control System.>
	3. Check the door lock switch and the circuit.	<Ref. to SL-10, CHECK DOOR LOCK SWITCH AND CIRCUIT, INSPECTION, Door Lock Control System.>
	4. Check the door lock actuator and the circuit.	<Ref. to SL-12, CHECK DOOR LOCK ACTUATOR AND CIRCUIT, INSPECTION, Door Lock Control System.>
The door lock switch does not operate.	Check the door lock switch and the circuit.	<Ref. to SL-10, CHECK DOOR LOCK SWITCH AND CIRCUIT, INSPECTION, Door Lock Control System.>
A specific door lock actuator does not operate.	Check the door lock actuator and the circuit.	<Ref. to SL-12, CHECK DOOR LOCK ACTUATOR AND CIRCUIT, INSPECTION, Door Lock Control System.>
The key cylinder lock switch does not operate. (with double lock)	Check the key cylinder lock switch and circuit.	<Ref. to SL-12, CHECK KEY CYLINDER LOCK SWITCH AND CIRCUIT, INSPECTION, Door Lock Control System.>
The double lock does not operate. (with double lock)	Check the door lock actuator (double lock) and circuit.	<Ref. to SL-13, CHECK DOOR LOCK ACTUATOR (DOUBLE LOCK) AND CIRCUIT, INSPECTION, Door Lock Control System.>

2. CHECK FUSE

Step	Value	Yes	No
1 CHECK FUSE. Remove and visually check the fuse No. 2 (in the main fuse box). In the fuse blown out?	Fuse is not blown out.	Check the power supply and ground circuit. <Ref. to SL-10, CHECK POWER SUPPLY AND GROUND CIRCUIT, INSPECTION, Door Lock Control System.>	Replace the fuse with a new one.

DOOR LOCK CONTROL SYSTEM

SECURITY AND LOCKS

3. CHECK POWER SUPPLY AND GROUND CIRCUIT

Step	Value	Yes	No
1 CHECK POWER SUPPLY. 1) Disconnect the keyless entry control module or double lock module harness connector. 2) Measure the voltage between the harness connector terminal and chassis ground. <i>Connector & terminal</i> <i>Without double lock:</i> <i>(B176) No. 5, 16 (+) — Chassis ground (-):</i> <i>With double lock:</i> <i>(B324) No. 7, 8 (+) — Chassis ground (-):</i> Is the measured value more than specified value?	10 V	Go to step 2.	Check the harness for open circuits or shorts between the keyless entry control module or double lock module and the fuse.
2 CHECK GROUND CIRCUIT. Measure the resistance between the harness connector terminal and chassis ground. <i>Connector & terminal</i> <i>Without double lock:</i> <i>(B176) No. 6, 14 — Chassis ground:</i> <i>With double lock:</i> <i>(B324) No. 9 — Chassis ground:</i> Is the measured value less than specified value?	10 Ω	The power supply and ground circuit is OK.	Repair the harness.

4. CHECK DOOR LOCK SWITCH AND CIRCUIT

Step	Value	Yes	No
1 CHECK DOOR LOCK SWITCH CIRCUIT. 1) Disconnect the keyless entry control module or double lock module harness connector. 2) Measure the resistance between the harness connector terminal and chassis ground when moving the door lock switch to LOCK. <i>Connector & terminal</i> <i>Without double lock:</i> <i>(B176) No. 10 — Chassis ground:</i> <i>With double lock:</i> <i>(B325) No. 7 — Chassis ground:</i> Is the measured value less than specified value?	10 Ω	Go to step 2.	Go to step 3.
2 CHECK DOOR LOCK SWITCH CIRCUIT. Measure the resistance between the harness connector terminal and chassis ground when the door lock switch is moved to UNLOCK. <i>Connector & terminal</i> <i>Without double lock:</i> <i>(B176) No. 8 — Chassis ground:</i> <i>With double lock:</i> <i>(B325) No. 4 — Chassis ground:</i> Is the measured value less than specified value?	10 Ω	The door lock switch is OK.	Go to step 3.

DOOR LOCK CONTROL SYSTEM

Step	Value	Yes	No
<p>3</p> <p>CHECK DOOR LOCK SWITCH. 1) Disconnect the door lock switch harness connector. 2) Measure the resistance between the door lock switch terminals when moving the door lock switch to LOCK. <i>Connector & terminal</i> <i>LHD model:</i> <i>(D7) No. 5 — No. 9</i> <i>RHD model:</i> <i>(D7) No. 15 — Switch ground:</i></p> <p>Is the measured value less than specified value?</p>	<p>1 Ω</p>	<p>Go to step 4.</p>	<p>Replace the door lock switch.</p>
<p>4</p> <p>CHECK DOOR LOCK SWITCH. Measure the resistance between the door lock switch terminals when moving the door lock switch to UNLOCK. <i>Connector & terminal</i> <i>LHD model:</i> <i>(D7) No. 5 — No. 8</i> <i>RHD model:</i> <i>(D7) No. 16 — Switch ground:</i></p> <p>Is the measured value less than specified value?</p>	<p>1 Ω</p>	<p>Check the harness for open circuits or shorts between the keyless entry control module or double lock module and the door lock switch.</p>	<p>Replace the door lock switch.</p>

DOOR LOCK CONTROL SYSTEM

SECURITY AND LOCKS

5. CHECK DOOR LOCK ACTUATOR AND CIRCUIT

Step	Value	Yes	No
1 CHECK OUTPUT SIGNAL. Measure the voltage between the harness connector terminal of keyless entry control module or double lock module and chassis ground when moving the door lock switch to LOCK. <i>Connector & terminal</i> <i>Without double lock:</i> (B176) No. 18 (+) — Chassis ground (-): <i>With double lock:</i> (B324) No. 3 (+) — Chassis ground (-): Is the measured value more than specified value?	10 V	Go to step 2.	Replace the keyless entry control module or double lock module.
2 CHECK OUTPUT SIGNAL. Measure the voltage between the harness connector terminal of keyless entry control module or double lock module and chassis ground when moving the door lock switch to UNLOCK. <i>Connector & terminal</i> <i>Without double lock:</i> (B176) No. 17 (+) — Chassis ground (-): <i>With double lock:</i> (B324) No. 5 (+) — Chassis ground (-): Is the measured value more than specified value?	10 V	Go to step 3.	Replace the keyless entry control module or double lock module.
3 CHECK DOOR LOCK ACTUATOR. Check the door lock actuator. Front door lock actuator: <Ref. to SL-25, Front Door Lock Actuator.> Rear door lock actuator: <Ref. to SL-29, Rear Door Lock Actuator.> Rear gate latch lock actuator: <Ref. to SL-32, Rear Gate Latch Lock Actuator.> Is the door lock actuator OK?	Door lock actuator is OK.	Check the harness for open circuits or shorts between the keyless entry control module or double lock module and the door lock actuator.	Replace the door lock actuator.

6. CHECK KEY CYLINDER LOCK SWITCH AND CIRCUIT

Step	Value	Yes	No
1 CHECK KEY CYLINDER LOCK SWITCH CIRCUIT. 1) Disconnect the double lock module harness connector. 2) Measure the resistance between harness connector terminal and chassis ground when turning the key cylinder lock switch to lock position. <i>Connector & terminal</i> (B325) No. 2 — Chassis ground: Is the measured value less than specified value?	10 Ω	Go to step 2.	Go to step 3.

DOOR LOCK CONTROL SYSTEM

SECURITY AND LOCKS

Step	Value	Yes	No
<p>2 CHECK KEY CYLINDER LOCK SWITCH CIRCUIT. Measure the resistance between harness connector terminal and chassis ground when turning the key cylinder lock switch to unlock position. Connector & terminal (B325) No. 3 — Chassis ground: Is the measured value less than specified value?</p>	10 Ω	Key cylinder lock switch is normal.	Go to step 3.
<p>3 CHECK KEY CYLINDER LOCK SWITCH. 1) Disconnect the key cylinder lock switch connector. 2) Measure the resistance between key cylinder lock switch terminals when turning the key cylinder lock switch to lock position. Terminals No. 1 — No. 2 Is the measured value less than specified value?</p>	1 Ω	Go to step 4.	Replace the key cylinder lock switch.
<p>4 CHECK KEY CYLINDER LOCK SWITCH. Measure the resistance between key cylinder lock switch terminals when turning the key cylinder lock switch to unlock position. Terminals No. 2 — No. 3 Is the measured value less than specified value?</p>	1 Ω	Check the harness for open or short circuits between double lock module and key cylinder lock switch.	Replace the key cylinder lock switch.

7. CHECK DOOR LOCK ACTUATOR (DOUBLE LOCK) AND CIRCUIT

Step	Value	Yes	No
<p>1 CHECK OUTPUT SIGNAL. Measure the resistance between double lock module harness connector terminal and chassis ground when turning the key cylinder lock switch to lock position. Connector & terminal (B324) No. 6 (+) — Chassis ground (-): Is the measured value more than specified value?</p>	10 V	Go to step 2.	Replace the double lock module.
<p>2 CHECK OUTPUT SIGNAL. Measure the resistance between double lock module harness connector terminal and chassis ground when turning the key cylinder lock switch to unlock position. Connector & terminal (B324) No. 6 (+) — Chassis ground (-): Is the measured value more than specified value?</p>	10 V	Go to step 3.	Replace the double lock module.
<p>3 CHECK DOOR LOCK ACTUATOR. Check door lock actuator. Front door lock actuator: <Ref. to SL-25, Front Door Lock Actuator.> Rear door lock actuator: <Ref. to SL-29, Rear Door Lock Actuator.> Is the door lock actuator normal?</p>	Door lock actuator is normal.	Check the harness for open or short circuits between double lock module and door lock actuator.	Replace the door lock actuator.

KEYLESS ENTRY SYSTEM

SECURITY AND LOCKS

3. Keyless Entry System

A: SCHEMATIC

<Ref. to WI-180, SCHEMATIC, Keyless Entry System.>

B: ELECTRICAL SPECIFICATION

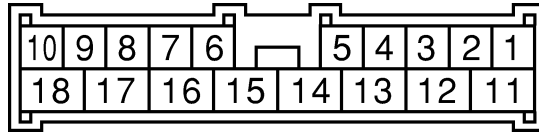

SL-00036

Content	Terminal No.	Measuring condition
Key warning switch	1 (INPUT)	Battery voltage is present when inserting the key into ignition switch.
Registration connector	2 (INPUT)	0 V is present when connecting the registration connector.
Door switch	3 (INPUT)	0 V is present when any door is open.
Power supply	5	Battery voltage is constantly present.
Empty	6	—
Empty	7	—
Door lock switch (Unlock)	8 (INPUT)	0 V is present when the door lock switch is turned to unlock position.
Empty	9	—
Door lock switch (Lock)	10 (INPUT)	0 V is present when the door lock switch is turned to lock position.
Room light/Ignition switch illumination	11 (OUTPUT)	<ul style="list-style-type: none"> • 0 V is present when pressing the transmitter OPEN button. • 0 V is present when any door is open.
Turn signal light (Left)	12 (OUTPUT)	Battery voltage is present when pressing the transmitter OPEN or LOCK button.
Turn signal light (Right)	13 (OUTPUT)	Battery voltage is present when pressing the transmitter OPEN or LOCK button.
Ground	14	0 V is constantly present.
Power supply (Hazard light)	15	Battery voltage is constantly present.
Power supply	16	Battery voltage is constantly present.
Door, rear gate lock actuator (without double lock) or double lock module (with double lock)	17 (OUTPUT)	Battery voltage is present when pressing the transmitter OPEN button.
Door, rear gate lock actuator (without double lock) or double lock module (with double lock)	18 (OUTPUT)	Battery voltage is present when pressing the transmitter LOCK button.

C: INSPECTION

1. SYMPTOM CHART

Symptom	Repair order	Reference
None of the functions of keyless entry system operate.	1. Check the transmitter battery.	<Ref. to SL-16, CHECK TRANSMITTER BATTERY, INSPECTION, Keyless Entry System.>
	2. Check the fuse.	<Ref. to SL-16, CHECK FUSE, INSPECTION, Keyless Entry System.>
	3. Check the keyless entry control module power supply and ground circuit.	<Ref. to SL-16, CHECK POWER SUPPLY AND GROUND CIRCUIT, INSPECTION, Keyless Entry System.>
	4. Replace the keyless entry control module.	<Ref. to SL-39, Keyless Entry Control Module.>
The transmitter cannot be registered.	1. Check the transmitter battery.	<Ref. to SL-16, CHECK TRANSMITTER BATTERY, INSPECTION, Keyless Entry System.>
	2. Check the registration connector circuit.	<Ref. to SL-17, CHECK REGISTRATION CONNECTOR CIRCUIT, INSPECTION, Keyless Entry System.>
	3. Replace the keyless entry control module.	<Ref. to SL-39, Keyless Entry Control Module.>
The door lock or unlock does not operate. NOTE: If the door lock control system does not operate when using the door lock switch, check the door lock control system. <Ref. to SL-9, INSPECTION, INSPECTION, Door Lock Control System.>	1. Check the transmitter battery.	<Ref. to SL-16, CHECK TRANSMITTER BATTERY, INSPECTION, Keyless Entry System.>
	2. Check the key warning switch.	<Ref. to SL-19, CHECK KEY WARNING SWITCH, INSPECTION, Keyless Entry System.>
	3. Check the door switch.	<Ref. to SL-18, CHECK DOOR SWITCH, INSPECTION, Keyless Entry System.>
	4. Check output signal to double lock module. (with double lock)	<Ref. to SL-21, CHECK OUTPUT SIGNAL TO DOUBLE LOCK MODULE, INSPECTION, Keyless Entry System.>
	5. Replace the keyless entry control module.	<Ref. to SL-39, Keyless Entry Control Module.>
The hazard light does not operate.	1. Check the hazard light operation.	<Ref. to SL-20, CHECK HAZARD LIGHT OPERATION, INSPECTION, Keyless Entry System.>
	2. Replace the keyless entry control module.	<Ref. to SL-39, Keyless Entry Control Module.>
The room light and ignition switch illumination operation does not activate.	1. Check the room light operation.	<Ref. to SL-20, CHECK ROOM LIGHT OPERATION, INSPECTION, Keyless Entry System.>
	2. Check the ignition switch illumination circuit.	<Ref. to SL-21, CHECK IGNITION SWITCH ILLUMINATION CIRCUIT, INSPECTION, Keyless Entry System.>
	3. Replace the keyless entry control module. (without double lock)	<Ref. to SL-39, Keyless Entry Control Module.>
	4. Replace the double lock module. (with double lock)	<Ref. to SL-40, Double Lock Module.>

KEYLESS ENTRY SYSTEM

SECURITY AND LOCKS

2. CHECK TRANSMITTER BATTERY

Step	Value	Yes	No
1 CHECK TRANSMITTER BATTERY. 1)Remove the battery from transmitter. <Ref. to SL-41, REMOVAL, Keyless Transmitter.> 2)Check the battery voltage. <Ref. to SL-41, INSPECTION, Keyless Transmitter.> Is the measured value more than specified value?	2 V	Further inspection is necessary, refer to "SYMPTOM CHART". <Ref. to SL-15, SYMPTOM CHART, INSPECTION, Keyless Entry System.>	Replace the transmitter battery.

3. CHECK FUSE

Step	Value	Yes	No
1 CHECK FUSE. Remove and visually check the fuse No. 2 (in the main fuse box), No. 3 (in the fuse and relay box) and SBF-6 (in the main fuse box) Is the fuse blown out?	Fuse is not blown out.	Check the power supply and ground circuit. <Ref. to SL-16, CHECK POWER SUPPLY AND GROUND CIRCUIT, INSPECTION, Keyless Entry System.>	Replace the fuse with a new one.

4. CHECK POWER SUPPLY AND GROUND CIRCUIT

Step	Value	Yes	No
1 CHECK POWER SUPPLY. 1)Disconnect the keyless entry control module harness connector. 2)Measure the voltage between harness connector terminal and chassis ground. Connector & terminal (B176) No. 5, No. 16 (+) — Chassis ground (-): Is the measured value more than specified value?	10 V	Go to step 2.	Check the harness for open circuits or shorts between keyless entry control module and fuse.
2 CHECK GROUND CIRCUIT. Measure the resistance between harness connector terminal and chassis ground. Connector & terminal (B176) No. 6, No. 14 — Chassis ground: Is the measured value less than specified value?	10 Ω	The power supply and ground circuit are OK.	Repair the harness.

5. CHECK REGISTRATION CONNECTOR CIRCUIT

Step	Value	Yes	No
1 REGISTRATION CONNECTOR INPUT VOLTAGE INSPECTION 1) Disconnect the registration connector. 2) Measure the voltage between keyless entry control module harness connector and chassis ground. <i>Connector & terminal</i> <i>(B176) No. 2 (+) — Chassis ground (-):</i> Is the measured value more than specified value?	10 V	Go to step 2.	Repair the harness, and (or) connector.
2 REGISTRATION CONNECTOR INPUT VOLTAGE INSPECTION 1) Connect the registration connector. 2) Measure the voltage between keyless entry control module harness connector and chassis ground. <i>Connector & terminal</i> <i>(B176) No. 2 (+) — Chassis ground (-):</i> Is the measured value less than specified value?	0 V	Registration connector circuit is OK.	Repair the harness, and (or) connector.

KEYLESS ENTRY SYSTEM

SECURITY AND LOCKS

6. CHECK DOOR SWITCH

	Step	Value	Yes	No
1	<p>CHECK DOOR SWITCH CIRCUIT. Measure the voltage between keyless entry control module harness connector terminal and chassis ground. Connector & terminal (B176) No. 3 (+) — Chassis ground (-): Is the measured value less than specified value when any one of the doors or rear gate is opened?</p>	0 V	Go to step 2.	Go to step 3.
2	<p>CHECK DOOR SWITCH CIRCUIT. Measure the voltage between keyless entry control module harness connector terminal and chassis ground. Connector & terminal (B176) No. 3 (+) — Chassis ground (-): Is the measured value more than specified value when all doors and rear gate are closed?</p>	10 V	The door switch is OK.	Go to step 3.
3	<p>CHECK DOOR SWITCH. 1) Disconnect the door switch harness connector. 2) Measure the resistance between door switch terminals. Terminal Door switch No. 1 — No. 3: Rear gate latch switch No. 1 — No. 2: Is the measured value more than specified value when the door switch is pressed?</p>	1 MΩ	Go to step 4.	Replace the door switch.
4	<p>CHECK DOOR SWITCH. Measure the resistance between door switch terminals. Terminal Door switch No. 1 — No. 3: Rear gate latch switch No. 1 — No. 2: Is the measured value less than specified value when the door switch is released?</p>	1 Ω	Check the harness for open circuits or shorts between keyless entry control module and door switch.	Replace the door switch.

7. CHECK KEY WARNING SWITCH

Step	Value	Yes	No
1 CHECK FUSE. Remove and visually check the fuse No. 6 (in the main fuse box). Is the fuse blown out?	Fuse is not blown out.	Go to step 2.	Replace the fuse with a new one.
2 CHECK KEY WARNING SWITCH CIRCUIT. 1)Disconnect the keyless entry control module harness connector. 2)Insert the key into ignition switch. (LOCK position) 3)Measure the voltage between harness connector terminal and chassis ground. Connector & terminal (B176) No. 1 (+) — Chassis ground (-): Is the measured value more than specified value?	10 V	Go to step 3.	Go to step 4.
3 CHECK KEY WARNING SWITCH CIRCUIT. 1)Remove the key from ignition switch. 2)Measure the voltage between harness connector terminal and chassis ground. Connector & terminal (B176) No. 1 (+) — Chassis ground (-): Is the measured value less than specified value?	0 V	The key warning switch is OK.	Go to step 4.
4 CHECK KEY WARNING SWITCH. 1)Disconnect the key warning switch harness connector. 2)Insert the key into ignition switch. (LOCK position) 3)Measure the resistance between key warning switch terminals. Terminal No. 1 — No. 2: Is the measured value less than specified value?	1 Ω	Go to step 5.	Replace the key warning switch.
5 CHECK KEY WARNING SWITCH. 1)Remove the key from ignition switch. 2)Measure the resistance between key warning switch terminals. Terminal No. 1 — No. 2: Is the measured value more than specified value?	1 M Ω	Check the following: • Harness for open circuits or shorts between the key warning switch and fuse • Harness for open circuits and shorts between the keyless entry control module and key warning switch	Replace the key warning switch.

KEYLESS ENTRY SYSTEM

SECURITY AND LOCKS

8. CHECK HAZARD LIGHT OPERATION

Step	Value	Yes	No
1 CHECK HAZARD LIGHT OPERATION. Make sure the hazard light blinks when hazard switch is turned ON. Does the hazard light blink?	Hazard light blinks.	Go to step 2.	Check the hazard light circuit.
2 CHECK OUTPUT SIGNAL. 1)Remove the key from ignition switch. 2)Close all doors and rear gate. 3)Measure the voltage between keyless entry control module harness connector terminal and chassis ground when LOCK or OPEN button of transmitter is pressed. Connector & terminal (B176) No. 12, No. 13 (+) — Chassis ground (-): Is the measured value more than specified value?	10 V	Check the harness for open or short between keyless entry control module and turn signal lights.	Replace the keyless entry control module.

9. CHECK ROOM LIGHT OPERATION

Step	Value	Yes	No
1 CHECK ROOM LIGHT OPERATION. Make sure the room light illuminates when the room light switch is turned ON. Does the room light illuminate?	Room light illuminates.	Go to step 2.	Check the room light circuit.
2 CHECK HARNESS BETWEEN ROOM LIGHT AND KEYLESS ENTRY CONTROL MODULE (WITHOUT DOUBLE LOCK) OR DOUBLE LOCK MODULE (WITH DOUBLE LOCK). 1)Disconnect the keyless entry control module or double lock module harness connector and room light harness connector. 2)Measure the resistance between keyless entry control module or double lock module harness connector terminal and room light harness connector terminal. Connector & terminal Without double lock: (B176) No. 11 — (R52) No. 2: With double lock: (B325) No. 1 — (R52) No. 2: Is the measured value less than specified value?	10 Ω	The room light operation circuit is OK.	Check the harness for open circuits or shorts between keyless entry control module (without double lock) or double lock module (with double lock) and room light.

10.CHECK IGNITION SWITCH ILLUMINATION CIRCUIT

Step	Value	Yes	No
<p>1 CHECK IGNITION SWITCH ILLUMINATION POWER SUPPLY. 1)Disconnect the ignition switch illumination harness connector. 2)Measure the voltage between ignition switch illumination harness connector terminal and chassis ground. <i>Connector & terminal</i> <i>(B224) No. 1 (+) — Chassis ground (-):</i> Is the measured value more than specified value?</p>	10 V	Go to step 2.	Check the harness for open circuit or shorts between ignition switch illumination and fuse.
<p>2 CHECK HARNESS BETWEEN IGNITION SWITCH ILLUMINATION AND KEYLESS ENTRY CONTROL MODULE (WITHOUT DOUBLE LOCK) OR DOUBLE LOCK MODULE (WITH DOUBLE LOCK). 1)Disconnect the keyless entry control module or double lock module harness connector. 2)Measure the resistance between keyless entry or double lock module harness connector terminal and ignition switch illumination harness connector. <i>Connector & terminal</i> <i>Without double lock:</i> <i>(B176) No. 11 — (R224) No. 2:</i> <i>With double lock:</i> <i>(B325) No. 1 — (R224) No. 2:</i> Is the measured value less than specified value?</p>	10 Ω	Check the ignition switch illumination. If NG, replace the ignition switch illumination.	Repair the harness.

11.CHECK OUTPUT SIGNAL TO DOUBLE LOCK MODULE

Step	Value	Yes	No
<p>1 CHECK OUTPUT SIGNAL. Measure the voltage between the keyless entry control module harness connector terminal and chassis ground when OPEN button of transmitter is pressed. <i>Connector & terminal</i> <i>(B176) No. 17 (+) — Chassis ground (-):</i> Is the measured value more than specified value?</p>	10 V	Go to step 2.	Replace the keyless entry control module.
<p>2 CHECK OUTPUT SIGNAL. Measure the voltage between the keyless entry control module harness connector terminal and chassis ground when LOCK button of transmitter is pressed. <i>Connector & terminal</i> <i>(B176) No. 18 (+) — Chassis ground (-):</i> Is the measured value more than specified value?</p>	10 V	Replace the double lock module.	Check the harness for open circuit or shorts between the keyless entry control module and double lock module.

4. Front Inner Remote

A: REMOVAL

- 1) Remove the door trim. <Ref. to EI-35, REMOVAL, Front Door Trim.>
- 2) Remove the sealing cover. <Ref. to EB-13, REMOVAL, Front Sealing Cover.>
- 3) Remove a screw and two cables.
- 4) Remove the front inner remote.

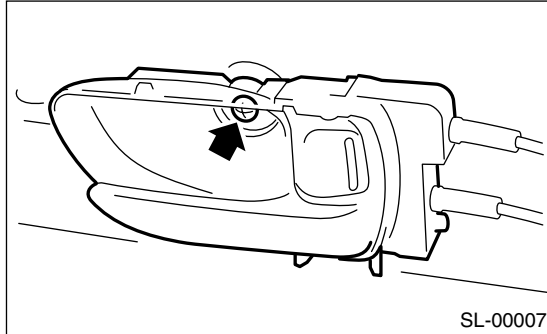

B: INSTALLATION

Install in the reverse order of removal.

NOTE:

Make sure the inner remote works properly after installation.

C: INSPECTION

- 1) Make sure the cable is not deformed.
- 2) Make sure the lever and cable work smoothly.

NOTE:

If the remote handle is metalclad type, make sure that grease is sufficiently applied to the cable connection portion. If the grease is insufficient, apply additional grease to the cable connection portion before connecting the cable.

5. Front Outer Handle

A: REMOVAL

1) Remove the door trim. <Ref. to EI-35, REMOVAL, Front Door Trim.>

CAUTION:

Do not use excessive force to remove the door panel. This will deform it.

2) Remove the sealing cover. <Ref. to EB-13, REMOVAL, Front Sealing Cover.>

3) Remove the front inner remote. <Ref. to SL-22, REMOVAL, Front Inner Remote.>

4) Remove the cable from cable holder to make cable move freely.

5) Remove two bolts and rod clamp, and then remove the front outer handle.

NOTE:

The rear bolt can be removed from service hole (A) of inner panel by adjusting the glass position.

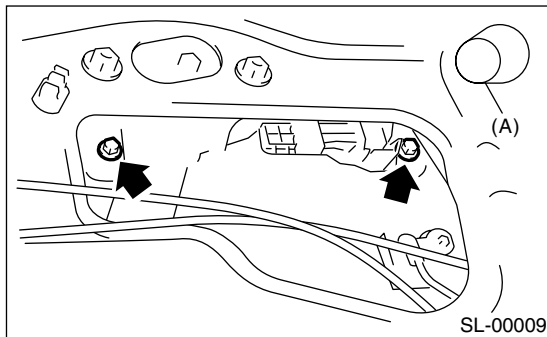

B: INSTALLATION

Install in the reverse order of removal.

NOTE:

Make sure the outer handle works properly after installation.

C: INSPECTION

- 1) Make sure the cable is not deformed.
- 2) Make sure the lever and rod work smoothly.

FRONT DOOR LATCH ASSEMBLY

SECURITY AND LOCKS

6. Front Door Latch Assembly

A: REMOVAL

- 1) Disconnect the ground cable from battery.
- 2) Remove the front door trim. <Ref. to EI-35, REMOVAL, Front Door Trim.>
- 3) Remove the sealing cover. <Ref. to EB-13, REMOVAL, Front Sealing Cover.>
- 4) Remove the front inner remote. <Ref. to SL-22, REMOVAL, Front Inner Remote.>
- 5) Remove two bolts and nut, and then remove the guide rail.

C: INSPECTION

- 1) Make sure the cable is not deformed.
- 2) Make sure the lever, rod and cable work smoothly.

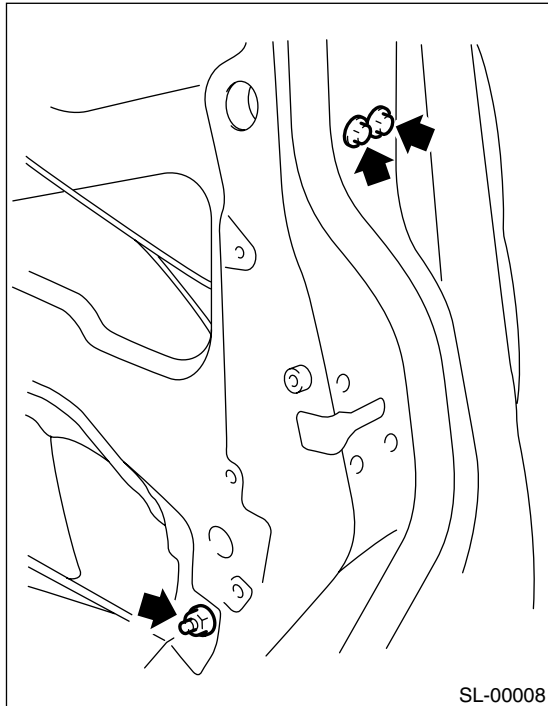

- 6) Remove the three screws and bolt.

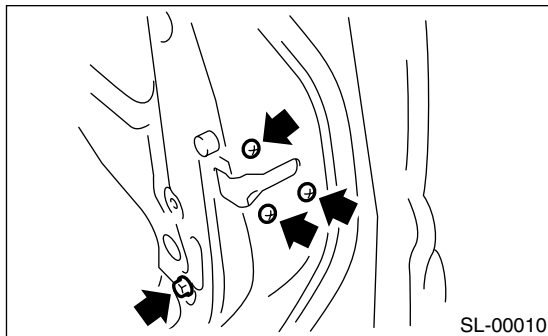

- 7) Remove the front door latch assembly, and then disconnect the connector.

B: INSTALLATION

Install in the reverse order of removal.

NOTE:

Make sure the lock works properly after installation.

7. Front Door Lock Actuator

A: REMOVAL

- 1) Remove the front door latch assembly. <Ref. to SL-24, REMOVAL, Front Door Latch Assembly.>
- 2) Loosen the two screws to remove front door lock actuator.

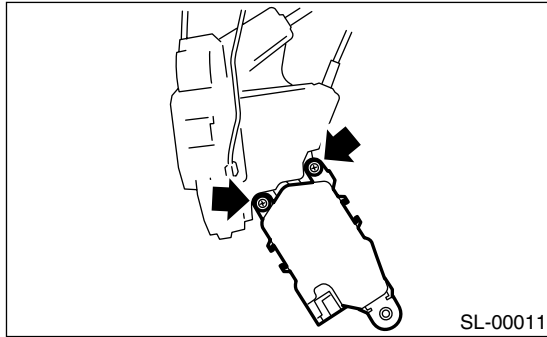

B: INSTALLATION

Install in the reverse order of removal.

NOTE:

Make sure the lock works properly after installation.

C: INSPECTION

- 1) Disconnect the door lock actuator harness connector.
- 2) Connect the battery to door lock actuator terminals.

If NG, replace the door lock actuator.

1. Without double lock:

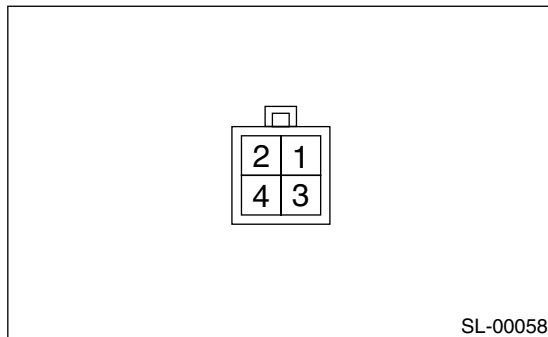

Terminal No.	Actuator operation
No. 2 (+) and No. 4 (-)	Unlocked → Locked
No. 4 (+) and No. 2 (-)	Locked → Unlocked

2. With double lock:

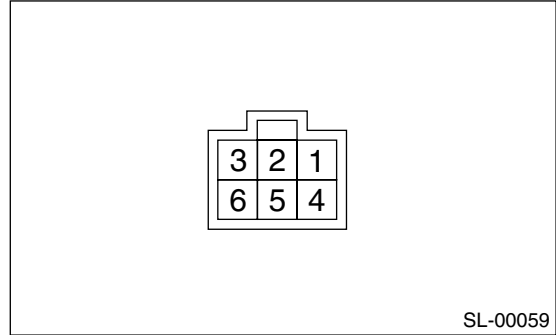

DOOR ACTUATOR RH:

Terminal No.	Actuator operation
No. 1 (+) and No. 4 (-)	Unlocked → Locked
No. 4 (+) and No. 1 (-)	Locked → Unlocked
No. 6 (+) and No. 3 (-)	Double lock released → Double lock set
No. 3 (+) and No. 6 (-)	Double lock set → Double lock released

DOOR ACTUATOR LH:

Terminal No.	Actuator operation
No. 6 (+) and No. 3 (-)	Unlocked → Locked
No. 3 (+) and No. 6 (-)	Locked → Unlocked
No. 1 (+) and No. 4 (-)	Double lock released → Double lock set
No. 4 (+) and No. 1 (-)	Double lock set → Double lock released

8. Rear Inner Remote

A: REMOVAL

- 1) Remove the rear door trim. <Ref. to EI-36, REMOVAL, Rear Door Trim.>
- 2) Remove the sealing cover. <Ref. to EB-16, REMOVAL, Rear Sealing Cover.>
- 3) Remove a screw and two cables.
- 4) Remove the inner remote.

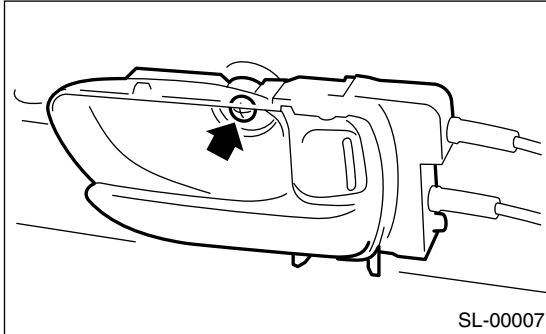

B: INSTALLATION

Install in the reverse order of removal.

NOTE:

Make sure the inner remote works properly after installation.

C: INSPECTION

- 1) Make sure the cable is not deformed.
- 2) Make sure the lever and cable work smoothly.
- 3) Make sure the child safety lock on rear doors work properly, when applicable.

NOTE:

If the remote handle is metalclad type, make sure that grease is sufficiently applied to the cable connection portion. If the grease is insufficient, apply additional grease to the cable connection portion before connecting the cable.

9. Rear Outer Handle

A: REMOVAL

1) Remove the rear door trim. <Ref. to EI-36, REMOVAL, Rear Door Trim.>

CAUTION:

Do not use excessive force to remove the door panel. This will deform it.

2) Remove the sealing cover. <Ref. to EB-16, REMOVAL, Rear Sealing Cover.>

3) Remove the rear inner remote. <Ref. to SL-26, REMOVAL, Rear Inner Remote.>

4) Remove the rear door latch assembly. <Ref. to SL-28, REMOVAL, Rear Door Latch Assembly.>

5) Remove two bolts, and then remove the rear outer handle.

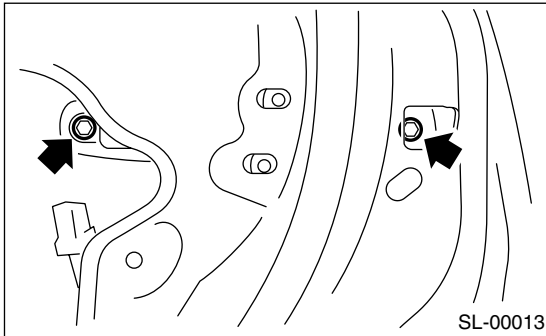

B: INSTALLATION

Install in the reverse order of removal.

NOTE:

Make sure the outer handle works properly after installation.

C: INSPECTION

1) Make sure the resinous lever is not deformed, damaged or cracked.

2) Make sure the resinous lever operate smoothly.

10.Rear Door Latch Assembly

A: REMOVAL

- 1) Disconnect the ground cable from battery.
- 2) Remove the rear door trim. <Ref. to EI-36, REMOVAL, Rear Door Trim.>
- 3) Remove the sealing cover. <Ref. to EB-16, REMOVAL, Rear Sealing Cover.>
- 4) Remove the rear inner remote. <Ref. to SL-26, REMOVAL, Rear Inner Remote.>
- 5) Remove the three screws and bolt.

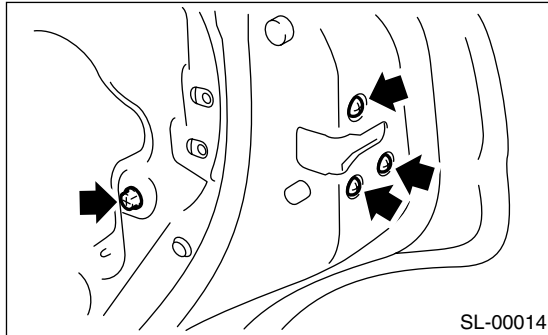

- 6) Remove the rear door latch assembly, and then disconnect the connector.

B: INSTALLATION

Install in the reverse order of removal.

NOTE:

Make sure the lock works properly after installation.

C: INSPECTION

- 1) Make sure the cable is not deformed.
- 2) Make sure the lever and cable work smoothly.

11. Rear Door Lock Actuator

A: REMOVAL

- 1) Remove the rear door latch assembly. <Ref. to SL-28, REMOVAL, Rear Door Latch Assembly.>
- 2) Loosen the two screws to remove rear door lock actuator.

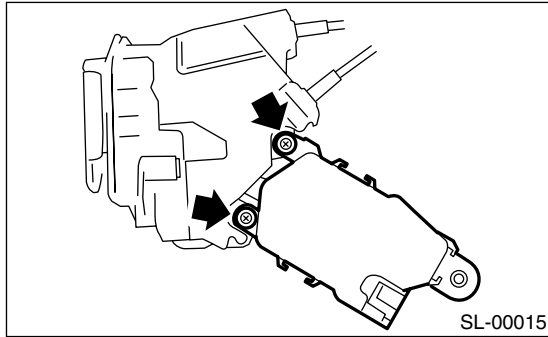

B: INSTALLATION

Install in the reverse order of removal.

NOTE:

Make sure the lock works properly after installation.

C: INSPECTION

- 1) Disconnect the door lock actuator harness connector.
- 2) Connect the battery to door lock actuator terminals.

If NG, replace the door lock actuator.

1. Without double lock

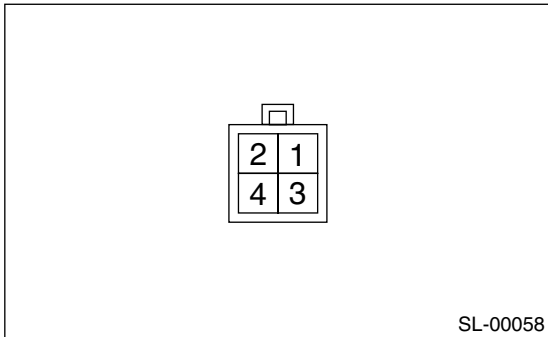

Terminal No.	Actuator operation
No. 2 (+) and No. 4 (-)	Unlocked → Locked
No. 4 (+) and No. 2 (-)	Locked → Unlocked

2. With double lock

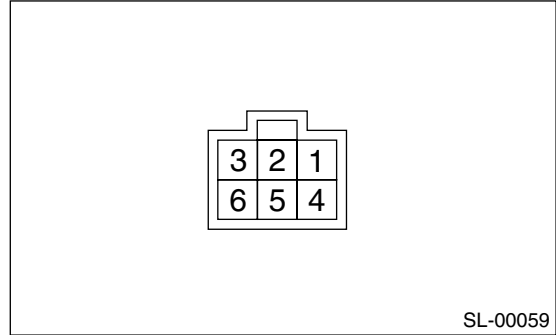

DOOR ACTUATOR RH:

Terminal No.	Actuator operation
No. 1 (+) and No. 4 (-)	Unlocked → Locked
No. 4 (+) and No. 1 (-)	Locked → Unlocked
No. 6 (+) and No. 3 (-)	Double lock released → Double lock set
No. 3 (+) and No. 6 (-)	Double lock set → Double lock released

DOOR ACTUATOR LH:

Terminal No.	Actuator operation
No. 6 (+) and No. 3 (-)	Unlocked → Locked
No. 3 (+) and No. 6 (-)	Locked → Unlocked
No. 1 (+) and No. 4 (-)	Double lock released → Double lock set
No. 4 (+) and No. 1 (-)	Double lock set → Double lock released

12.Rear Gate Outer Handle

A: REMOVAL

- 1) Remove the rear gate trim. <Ref. to EI-48, REMOVAL, Rear Gate Panel Trim.>
- 2) Remove the rear wiper motor assembly. <Ref. to WW-17, REMOVAL, Rear Gate Garnish.>
- 3) Remove the rear finisher.
- 4) Remove the cable, and then remove two nuts.

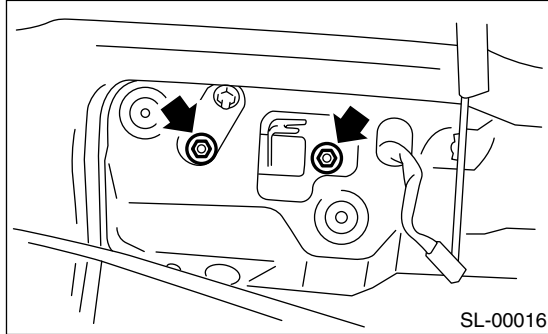

- 5) Remove the rear gate outer handle.

B: INSTALLATION

Install in the reverse order of removal.

NOTE:

Make sure the outer handle works properly after installation.

C: INSPECTION

- 1) Inspect the cable for deformation.
- 2) Make sure the lever and cable move smoothly.

13.Rear Gate Latch Assembly

A: REMOVAL

- 1) Disconnect the ground cable from battery.
- 2) Remove the rear gate trim. <Ref. to EI-48, REMOVAL, Rear Gate Panel Trim.>
- 3) Remove two bolts.

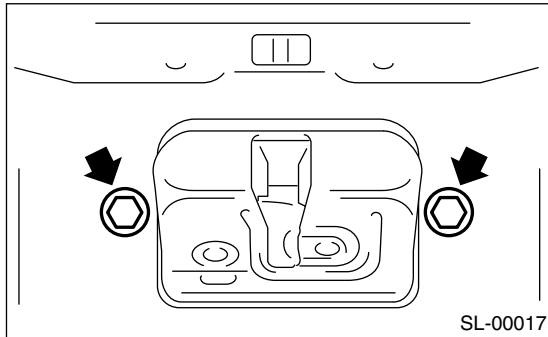

- 4) Remove the rear gate latch assembly, and then disconnect the connector.
- 5) Remove the rear gate outer handle cable, and then remove the rear gate latch assembly.
- 6) Disconnect the connectors, and then remove the rear gate latch assembly.

B: INSTALLATION

Install in the reverse order of removal.

NOTE:

Make sure the lock works properly after installation.

C: INSPECTION

- 1) Make sure the cable is not deformed.
- 2) Make sure the lever, cable, rear gate latch switch and door lock operate smoothly.

14. Rear Gate Latch Lock Actuator

A: REMOVAL

- 1) Remove the rear gate latch assembly. <Ref. to SL-31, REMOVAL, Rear Gate Latch Assembly.>
- 2) Remove three pawls, and then remove the rear gate latch lock actuator from rear gate latch assembly.

CAUTION:

Do not use excessive force to remove the rear gate latch lock actuator. The pawl surroundings of rear gate latch assembly will be deformed.

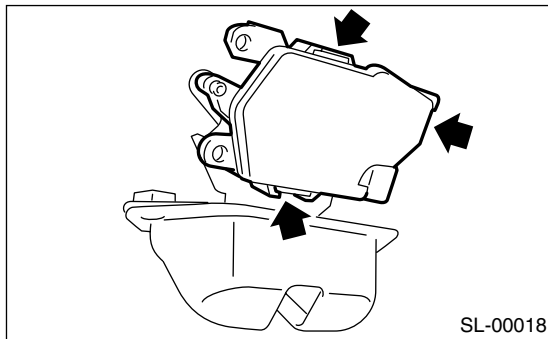

B: INSTALLATION

Install in the reverse order of removal.

CAUTION:

Be sure to align the lever groove of rear gate latch assembly and actuator lever.

NOTE:

Make sure the lock works properly after installation.

C: INSPECTION

- 1) Disconnect the door lock actuator harness connector.
- 2) Connect the battery to door lock actuator terminals.

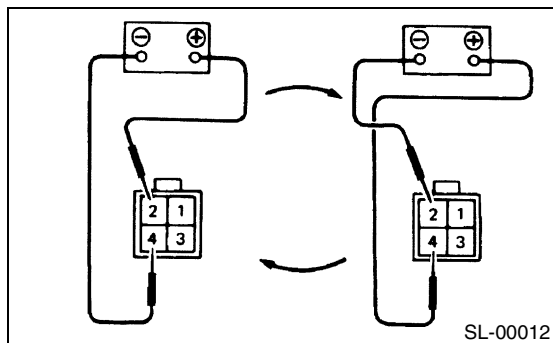

Terminal No.	Actuator operation
No. 4 (+) and No. 2 (-)	Unlocked → Locked
No. 2 (+) and No. 4 (-)	Locked → Unlocked

If NG, replace the rear gate latch lock actuator.

15. Front Hood Lock Assembly

A: REMOVAL

- 1) Open the hood.
- 2) Remove the front grille.
- 3) Remove the bolt. Remove the hood lock assembly.
- 4) Remove the release cable from lock assembly.

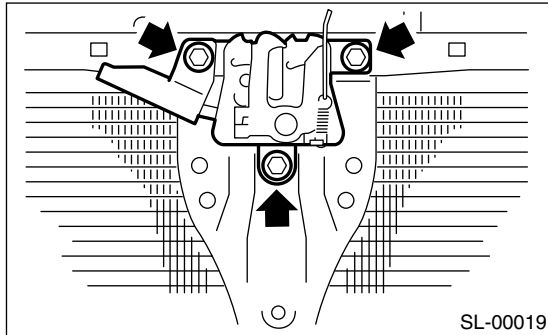

B: INSTALLATION

Install in the reverse order of removal.

NOTE:

- Apply grease to parts that rub.
- Make sure the release cable works properly after installation.

C: ADJUSTMENT

Loosen the bolt. Adjust the lock assembly while moving it up and down.

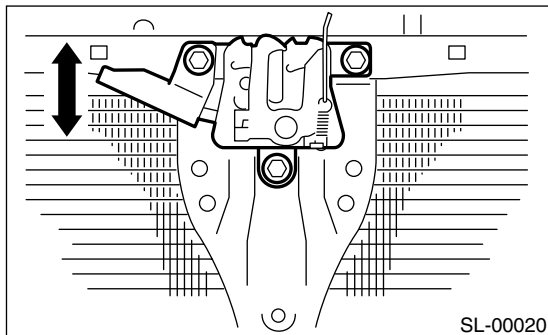

D: INSPECTION

- 1) Check the striker for bending or abnormal wear.
- 2) Check the safety lever for improper movement.
- 3) Check other levers and the spring for rust formation and unsmooth movement.

16. Remote Openers

A: REMOVAL

1. HOOD OPENER

- 1) Remove the front hood lock assembly. <Ref. to SL-33, REMOVAL, Front Hood Lock Assembly.>
- 2) Remove the release cable from hood lock.
- 3) Remove the bolt. Remove the opener lever.

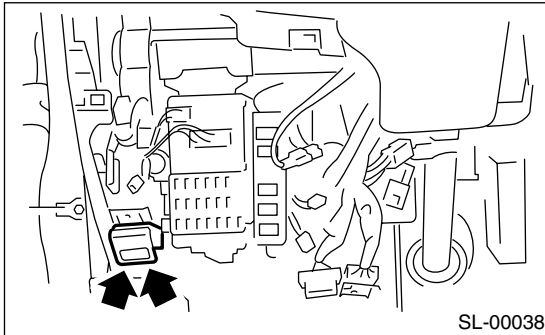

2. FUEL FLAP OPENER

- 1) Remove the rear seat. <Ref. to SE-10, REMOVAL, Rear Seat.>
- 2) Remove the center pillar lower trim and side sill cover. Remove the rear pillar lower trim. Pull back the floor mat.
- 3) Remove the right rear quarter trim. <Ref. to EI-45, REMOVAL, Rear Quarter Trim.> Remove the clip holding the cable.
- 4) Remove the bolt. Remove the opener pull handle.
- 5) Remove the cable (A) from opener pull handle (B).

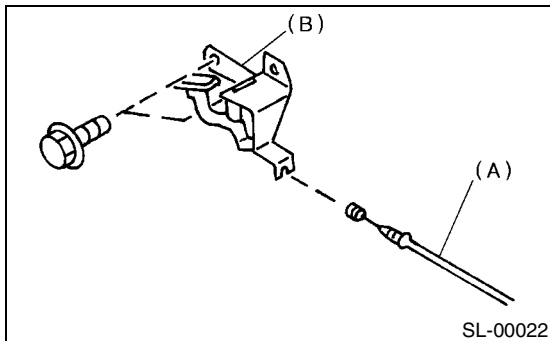

- 6) Rotate the fuel lock inside the quarter panel to left and remove.

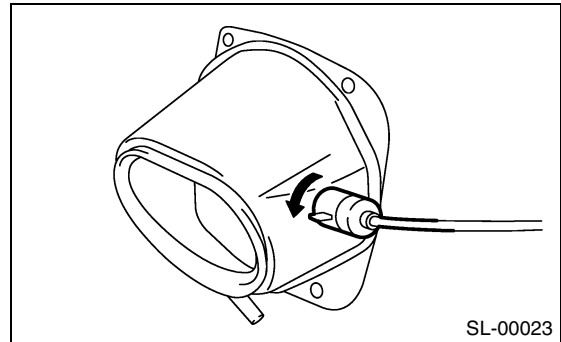

B: INSTALLATION

1. HOOD OPENER

Install in the reverse order of removal.

2. FUEL FLAP OPENER

Install in the reverse order of removal.

C: INSPECTION

Make sure the fuel flap opens and closes smoothly.

17. Ignition Key Lock

A: REPLACEMENT

- 1) Remove the ground cable from battery.
- 2) Remove the steering column. <Ref. to PS-26, REMOVAL, Tilt Steering Column.>
- 3) Secure the steering column in a vise. Remove the bolt with a drill.

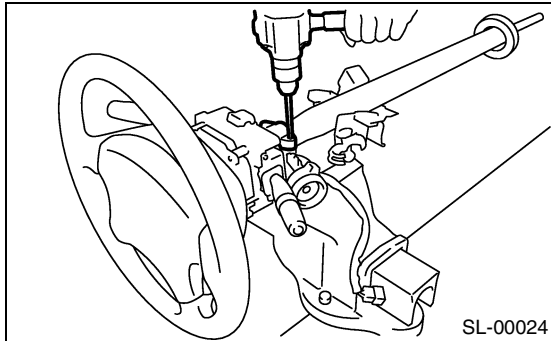

- 4) Remove the ignition key lock.
- 5) Use a new torn bolt. Tighten the torn bolt to end of thread.

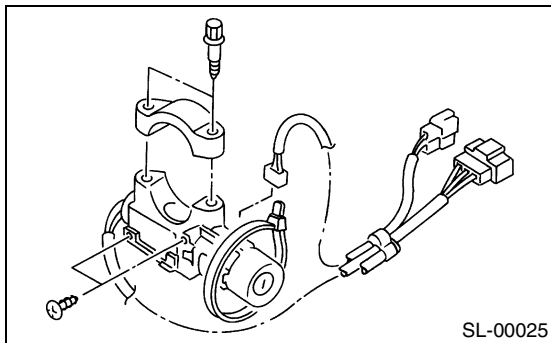

B: INSPECTION

- 1) Remove the instrument panel lower cover.
- 2) Remove the lower column cover.
- 3) Unfasten the holddown clip which secures harness and disconnect the connector of ignition switch from body harness.
- 4) Turn the ignition key plate to each position and check the continuity between terminals of ignition connector.

Switch position	Terminal No.	Standard
LOCK	—	—
ACC	No. 1 and No. 2	Less than 1 Ω
ON	No. 1 and No. 2 No. 1 and No. 4 No. 2 and No. 4	Less than 1 Ω
ST	No. 1 and No. 3 No. 1 and No. 4 No. 3 and No. 4	Less than 1 Ω

If NG, replace the ignition switch.

18. Key Lock Cylinder

A: REPLACEMENT

1. FRONT DOOR

• Without double lock:

- 1) Remove the door trim. <Ref. to EI-35, REMOVAL, Front Door Trim.>
- 2) Pull back the sealing cover. <Ref. to EB-13, REMOVAL, Front Sealing Cover.>
- 3) Close the front door glass completely.
- 4) Remove the rod clamp (A). Remove the lock plate (B). Replace the key cylinder.

CAUTION:

Be sure to replace the lock plate (B) with a new one.

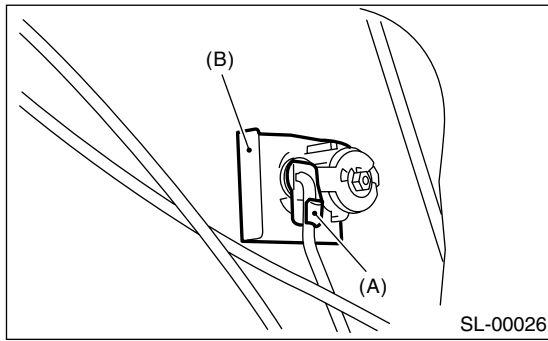

• With double lock:

- 1) Remove the door trim. <Ref. to EI-35, REMOVAL, Front Door Trim.>
- 2) Remove the sealing cover. <Ref. to EB-13, REMOVAL, Front Sealing Cover.>
- 3) Close the front door glass completely.
- 4) Remove the key cylinder retainer cover, and then remove the rod clamp (A).

CAUTION:

Be sure to replace the key cylinder retainer cover with a new one when removing.

- 5) Remove the bolt (B) and key cylinder retainer to replace the key cylinder.

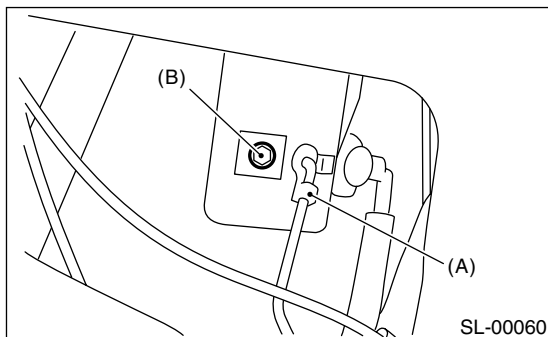

19. Immobilizer Control Module

A: REMOVAL

NOTE:

The following positions for removal and installation are for LHD models. The positions for RHD models are symmetrically opposite.

- 1) Disconnect the ground cable from battery.
- 2) Remove the instrument panel lower cover. <Ref. to EI-40, REMOVAL, Instrument Panel Assembly.>
- 3) Disconnect the connector from immobilizer control module.
- 4) Remove the immobilizer control module.

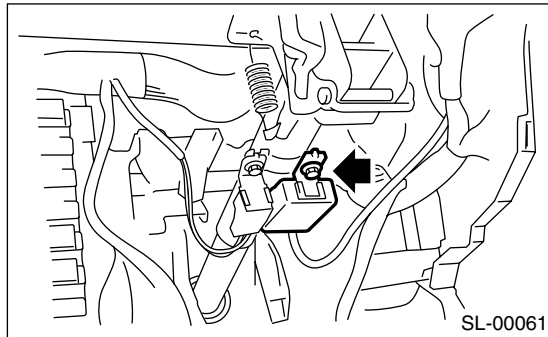

B: INSTALLATION

Install in the reverse order of removal.

20. Immobilizer Antenna

A: REMOVAL

- 1) Disconnect the ground cable from battery.
- 2) Remove the instrument panel lower cover. <Ref. to EI-40, REMOVAL, Instrument Panel Assembly.>
- 3) Remove the screws, separate upper column cover and lower column cover.

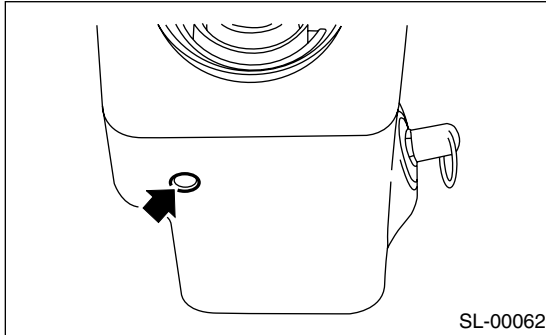

- 4) Disconnect the immobilizer antenna connector (A) from immobilizer control module.
- 5) Remove the screw, and detach the immobilizer antenna (B).

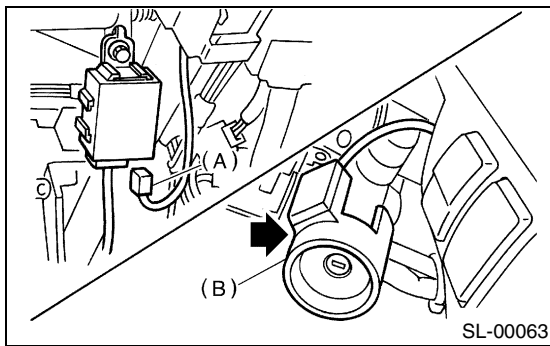

B: INSTALLATION

Install in the reverse order of removal.

21. Keyless Entry Control Module

A: REMOVAL

- 1) Disconnect the ground cable from battery.
- 2) Remove the glove box. <Ref. to EI-37, REMOVAL, Glove Box.>
- 3) Remove the nut, and then remove the keyless entry control module while disconnecting connector.

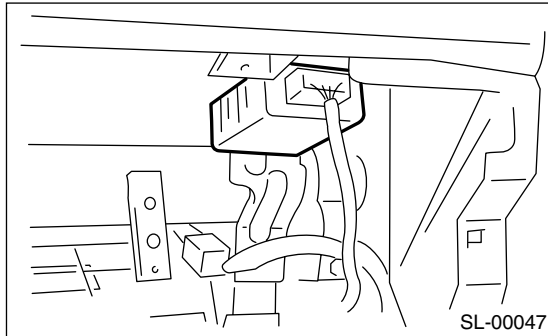

B: INSTALLATION

Install in the reverse order of removal.

22. Double Lock Module

A: REMOVAL

- 1) Disconnect the ground cable from battery.
- 2) Remove the instrument panel lower cover. <Ref. to EI-40, REMOVAL, Instrument Panel Assembly.>
- 3) Remove the nut, then remove the double lock module while disconnecting the connector.

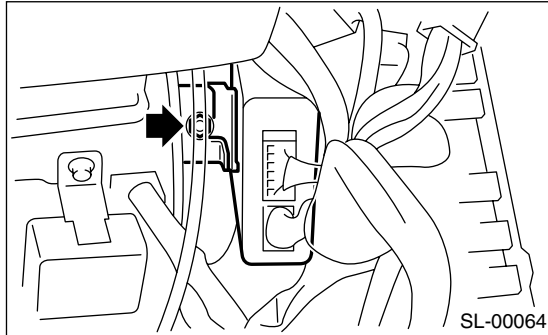

B: INSTALLATION

Install in the reverse order of removal.

23. Keyless Transmitter

A: REMOVAL

1. TRANSMITTER BATTERY

Remove the battery from transmitter.

NOTE:

To prevent static electricity damage to transmitter printed circuit board, touch the steel area of building with hand to discharge the static electricity carried on body or clothes before disassembling transmitter.

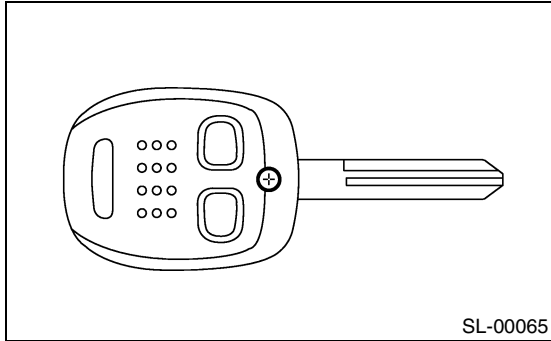

B: INSTALLATION

1. TRANSMITTER BATTERY

Install in the reverse order of removal.

C: INSPECTION

1. TRANSMITTER BATTERY

Measure the voltage between battery (+) terminal and (-) terminal.

NOTE:

- Battery discharge occurs during measurement. Complete the measurement within 5 seconds.
- During battery voltage measurement, voltage falls more than 1.8 volts in 3 seconds period.

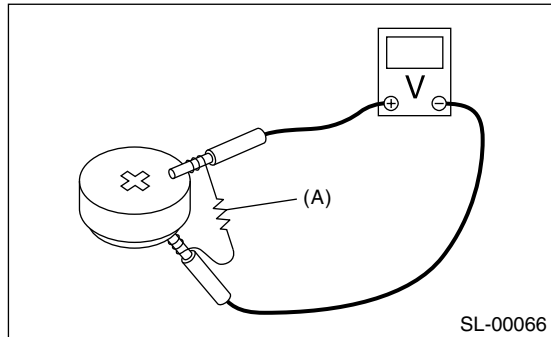

(A) Resistance 300 Ω

Tester connection		Standard
(+)	(-)	
Battery (+) terminal	Battery (-) terminal	2.5 — 3.0 V

If NG, replace the battery. (Use CR1620 or equivalent.)

D: REPLACEMENT

1. TRANSMITTER REGISTRATION

NOTE:

- A maximum of three transmitters can be registered for each individual vehicle.
 - When replacing the transmitter (key), registration to immobilizer system is also necessary.
- 1) Remove the side sill cover at driver's side, then connect the registration connectors at front pillar lower section.
 - 2) Unlock the door lock.
 - 3) Press any button of the transmitter twice while pressing driver's door lock switch to unlock side to be registered.
 - 4) The door lock will automatically lock and unlock in sequence. This indicates the completion of transmitter registration for first transmitter.
 - 5) If the registration of second and third transmitter is now to be carried out, repeat the procedure 3) and 4).
 - 6) Disconnect the registration connectors after the completion of all registration operations. After confirming the operation of door lock using newly registered transmitter(s), reinstall the side sill cover at driver's side.

KEYLESS TRANSMITTER

SECURITY AND LOCKS
