

EXTERIOR BODY PANELS



	Page
1. General Description	2
2. Front Hood	9
3. Fender Panel.....	10
4. Front Door Panel.....	11
5. Front Sealing Cover	13
6. Rear Door Panel	14
7. Rear Sealing Cover.....	16
8. Rear Gate Panel	17
9. Rear Gate Garnish Assembly	20

GENERAL DESCRIPTION

EXTERIOR BODY PANELS

1. General Description

A: SPECIFICATIONS

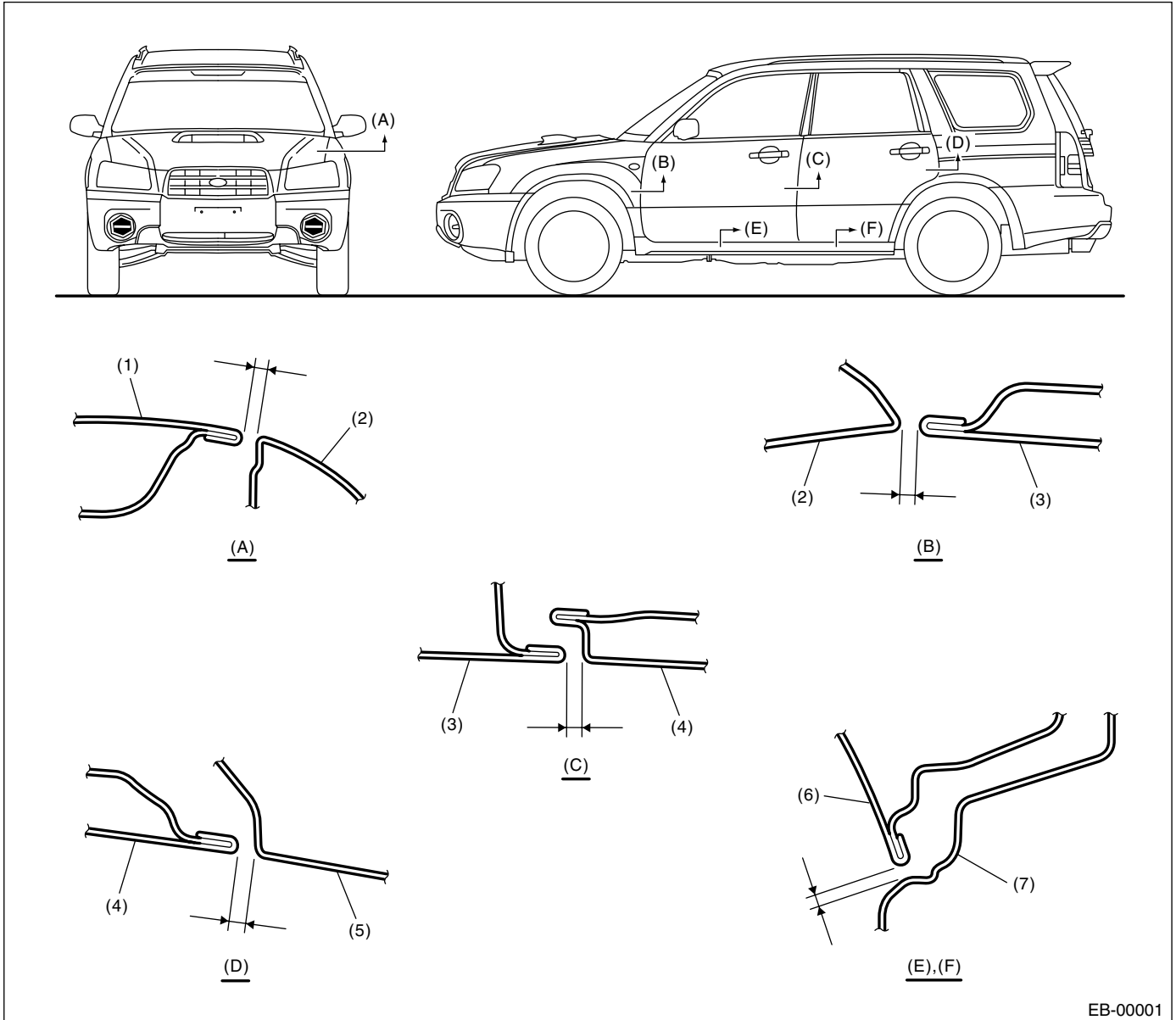

- | | | |
|------------------|------------------|---------------|
| (1) Front hood | (4) Rear door | (7) Side sill |
| (2) Front fender | (5) Rear quarter | |
| (3) Front door | (6) Door panel | |

Section	Part	Specification
(A)	Front hood to Front fender	3.5±1.0 (0.14±0.04 in)
(B)	Front fender to Front door	4.7±1.0 (0.19±0.04 in)
(C)	Front door to Rear door	5.0 (0.20 in)
(D)	Rear door to Rear quarter	4.6 (0.18 in)
(E), (F)	Door panel to Side sill	7.0 (0.28 in)

B: COMPONENT

1. FRONT HOOD

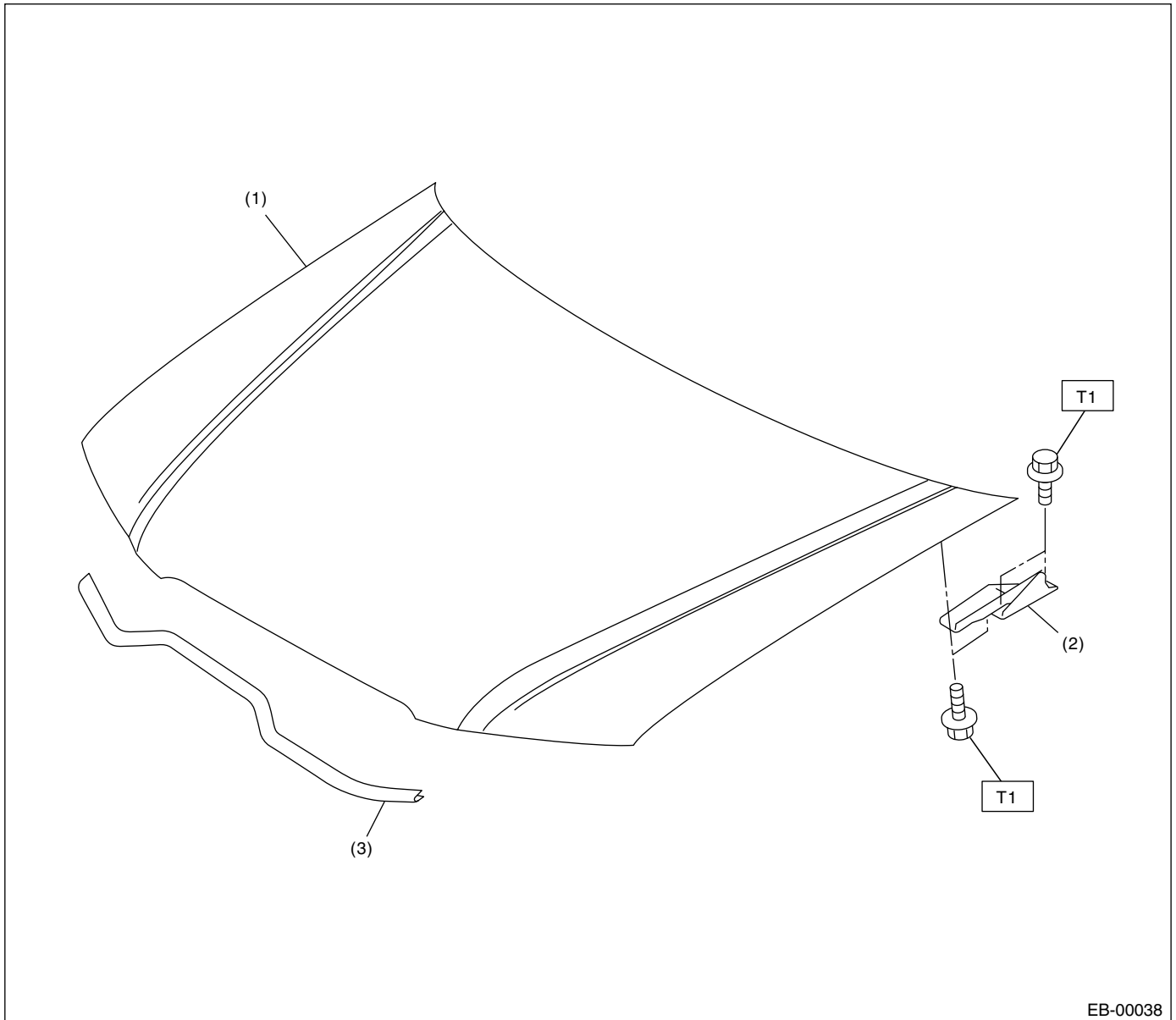

EB-00038

- (1) Front hood
- (2) Hinge

- (3) Seal

Tightening torque: N·m (kgf·m, ft·lb)
T1: 24.5 (2.5, 18.1)

GENERAL DESCRIPTION

EXTERIOR BODY PANELS

2. FRONT FENDER PANEL

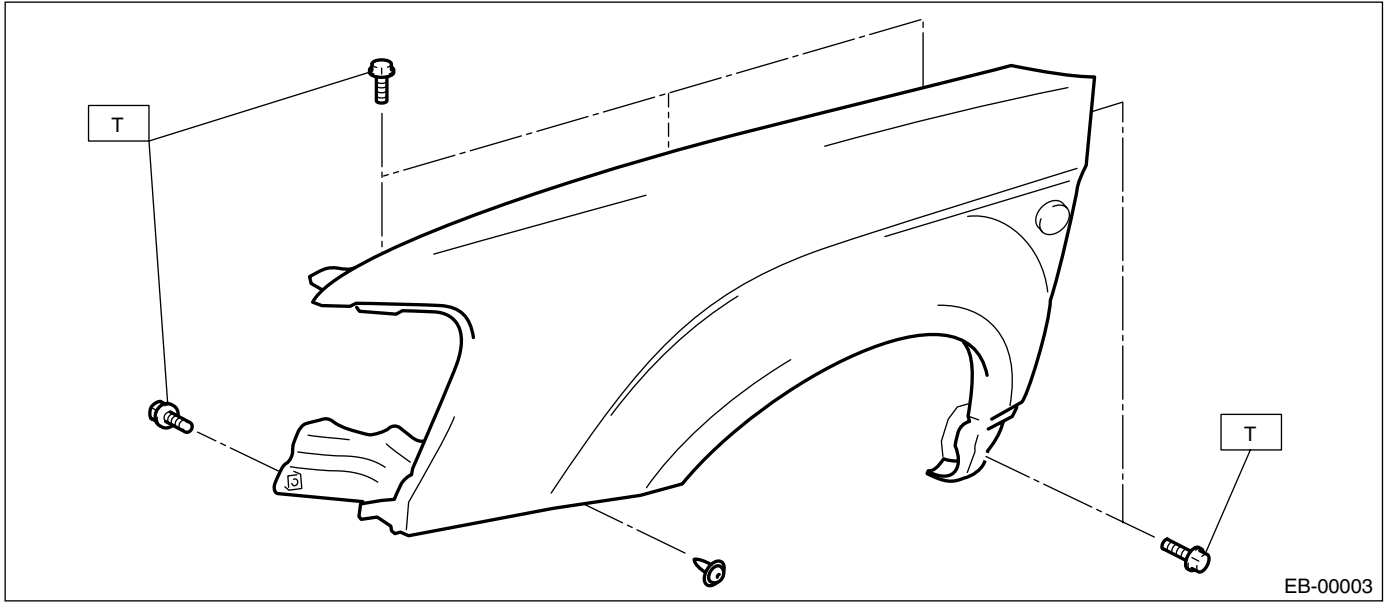

Tightening torque: N·m (kgf·m, ft·lb)
T: 7.4 (0.75, 5.5)

3. FRONT DOOR PANEL

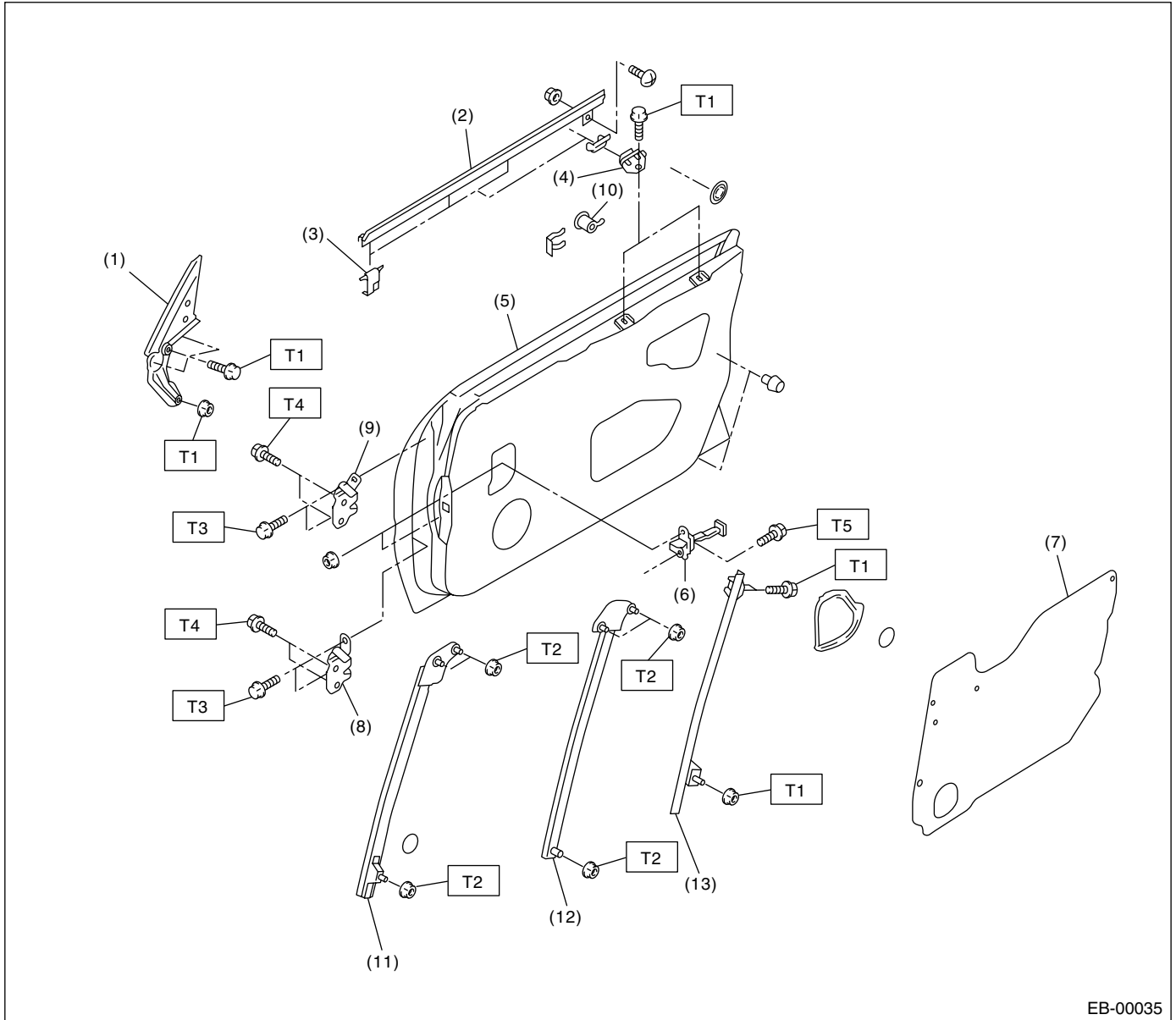

- | | |
|------------------------|--|
| (1) Gusset | (8) Lower hinge |
| (2) Weatherstrip | (9) Upper hinge |
| (3) Stabilizer (Outer) | (10) Key cylinder (Driver's side only) |
| (4) Stabilizer (Inner) | (11) Front sash |
| (5) Door panel | (12) Rear sash |
| (6) Checker | (13) Guide rail |
| (7) Sealing cover | |

Tightening torque: N-m (kgf-m, ft-lb)

T1: 7.35 (0.75, 5.4)

T2: 14 (1.4, 10.3)

T3: 25 (2.5, 18)

T4: 30 (3.1, 22)

T5: 32 (3.3, 24)

GENERAL DESCRIPTION

EXTERIOR BODY PANELS

4. REAR DOOR PANEL

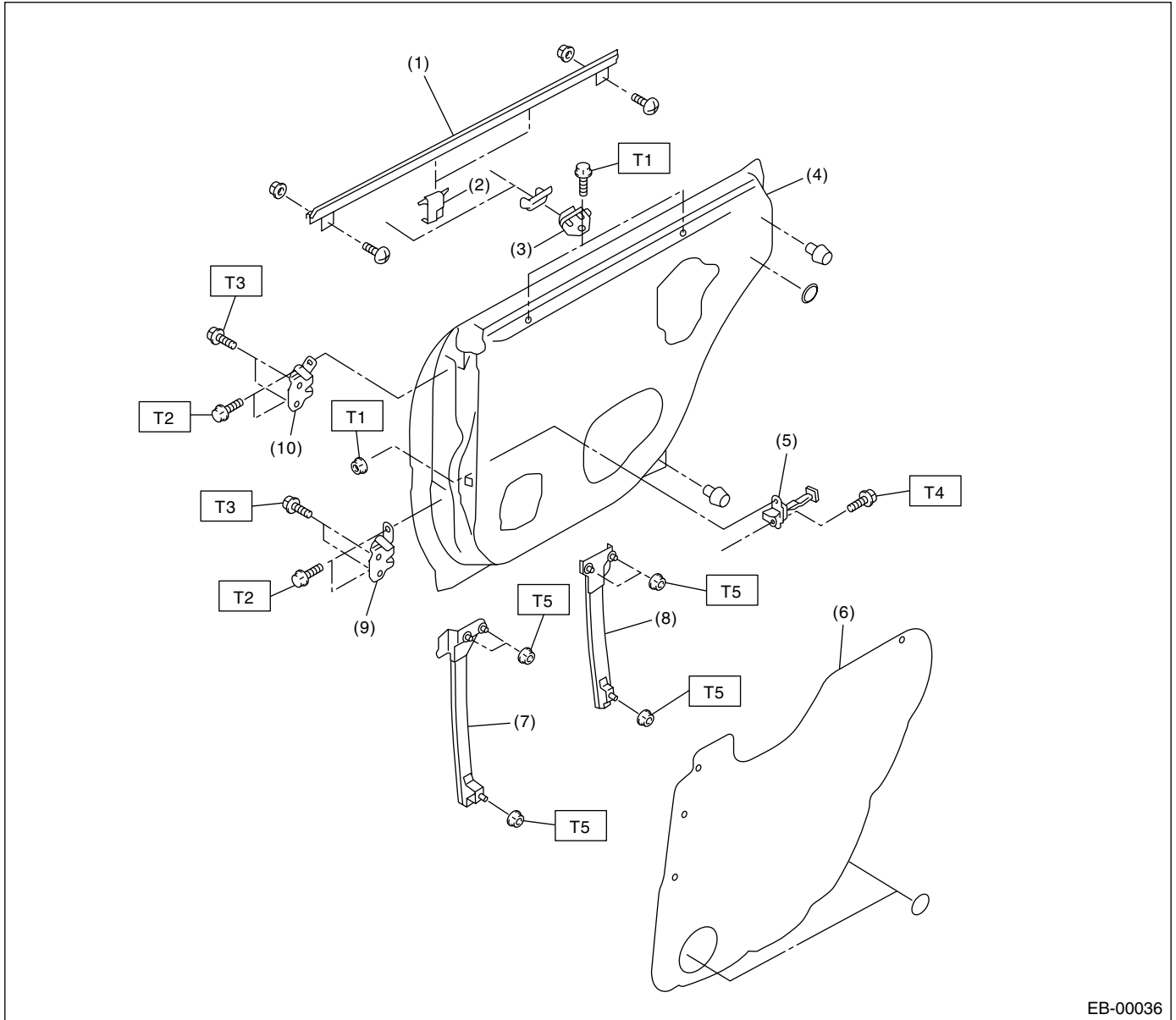

- | | |
|------------------------|------------------|
| (1) Weatherstrip | (7) Front sash |
| (2) Stabilizer (Outer) | (8) Rear sash |
| (3) Stabilizer (Inner) | (9) Lower hinge |
| (4) Door panel | (10) Upper hinge |
| (5) Checker | |
| (6) Sealing cover | |

Tightening torque: N-m (kgf-m, ft-lb)

T1: 7.35 (0.75, 5.4)

T2: 25 (2.5, 18)

T3: 30 (3.1, 18)

T4: 32 (3.3, 24)

T5: 14 (1.4, 10.3)

5. REAR GATE PANEL

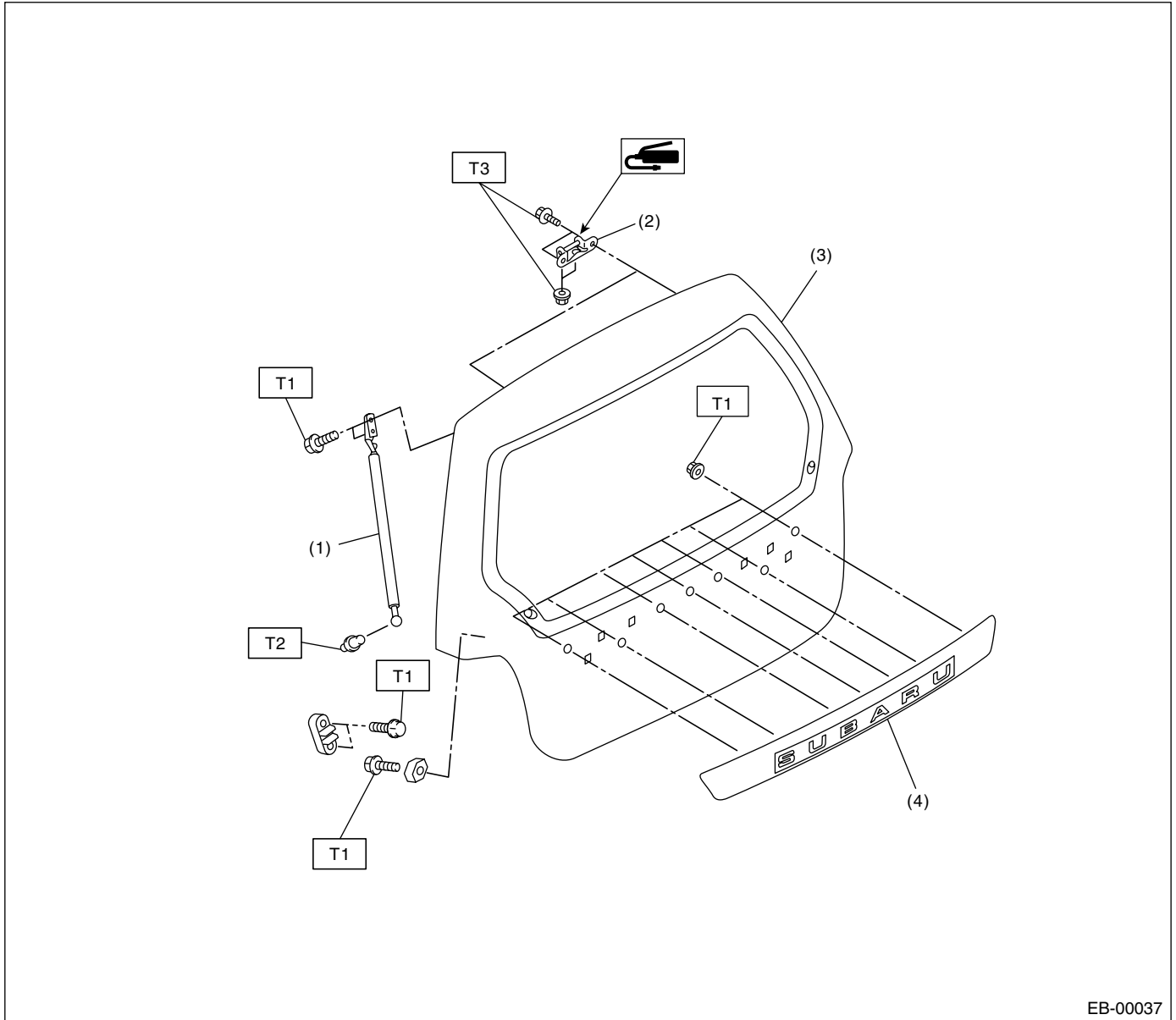

EB-00037

- (1) Gas stay
- (2) Hinge
- (3) Rear gate
- (4) Rear gate garnish

Tightening torque: N·m (kgf·m, ft·lb)

T1: 7.5 (0.76, 5.5)

T2: 14 (1.4, 10.1)

T3: 25 (2.5, 18.1)

GENERAL DESCRIPTION

EXTERIOR BODY PANELS

C: PREPARATION TOOL

1. SPECIAL TOOLS

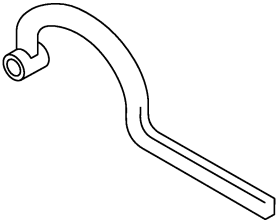
ILLUSTRATION	TOOL NUMBER	DESCRIPTION	REMARKS
 ST-925610000	925610000	WRENCH	Used for removing and installing door hinge.

2. GENERAL TOOL

TOOL NAME	REMARKS
Support Jack	Used for supporting door panel.

2. Front Hood

A: REMOVAL

- 1) Open the front hood to remove washer nozzles.
- 2) Release the clips to remove hood insulator.

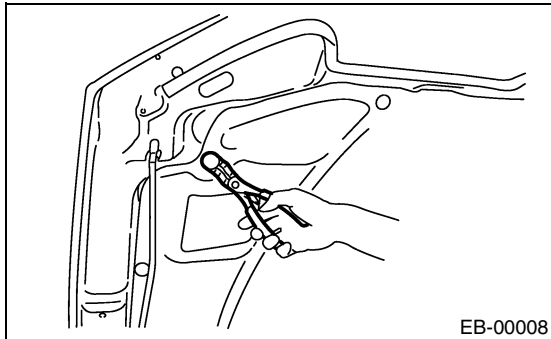

- 3) Remove the bolts to remove front hood from hinges.

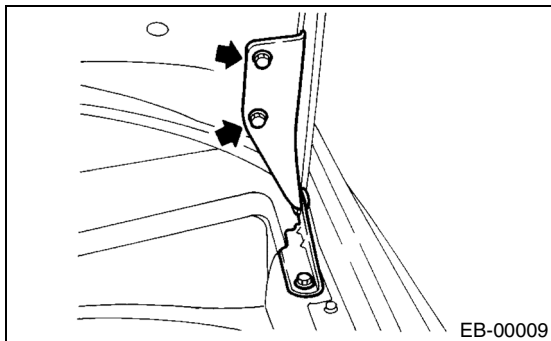

B: INSTALLATION

- 1) Install in the reverse order of removal.
- 2) Adjust the clearance between hood and fender. Clearance must be equal at both sides.

Tightening torque:

24.5 N-m (2.5 kgf-m, 18.1 ft-lb)

C: ADJUSTMENT

- 1) Use the hinge mounting holes to align the front hood longitudinally and laterally.

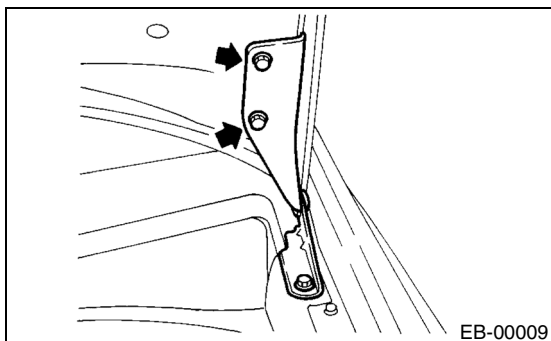

- 2) Adjust the height at front end of hood. <Ref. to SL-33, ADJUSTMENT, Front Hood Lock Assembly.>

- 3) Rotate the hood buffer to adjust lateral height.

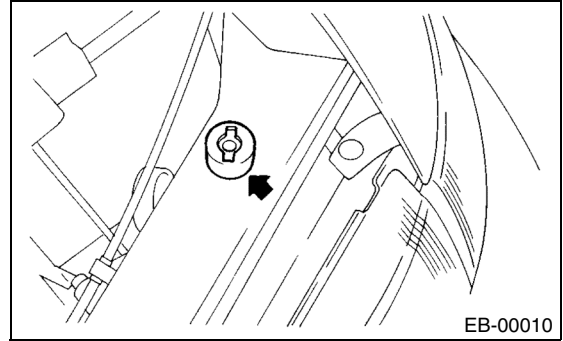

3. Fender Panel

A: REMOVAL

- 1) Disconnect the ground cable from battery.
- 2) Remove the front bumper face. <Ref. to EI-23, REMOVAL, Front Bumper.>
- 3) Remove the mud guard. <Ref. to EI-31, REMOVAL, Mud Guard.>
- 4) Remove the side sill spoiler. <Ref. to EI-33, REMOVAL, Side Sill Spoiler.>
- 5) Remove the side protector. <Ref. to EI-34, REMOVAL, Side Protector.>
- 6) Loosen the bolts and clip to remove front fender.

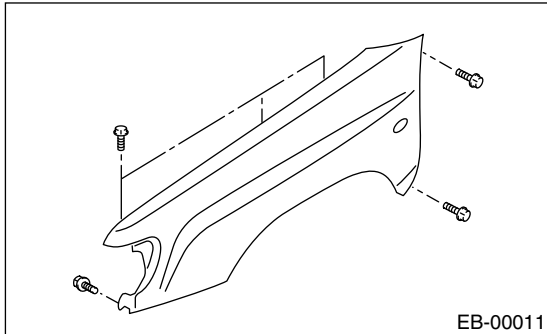

B: INSTALLATION

- 1) Install in the reverse order of removal.
- 2) When the fender panel is installed, clearance between fender panel and hood or front fender must be equal.

Tightening torque:

7.4 N-m (0.75 kgf-m, 5.5 ft-lb)

4. Front Door Panel

A: REMOVAL

- 1) Disconnect the ground cable from battery.
- 2) Remove the front door trim. <Ref. to EI-35, REMOVAL, Front Door Trim.>
- 3) Remove the outer mirror assembly. <Ref. to GW-11, REMOVAL, Outer Mirror Assembly.>
- 4) Remove the front sealing cover. <Ref. to EB-13, REMOVAL, Front Sealing Cover.>
- 5) Remove the front door glass. <Ref. to GW-16, REMOVAL, Front Door Glass.>
- 6) Remove the front door regulator and motor. <Ref. to GW-20, REMOVAL, Front Regulator and Motor Assembly.>
- 7) Remove the front door latch assembly. <Ref. to SL-23, REMOVAL, Front Outer Handle.>
- 8) Remove the front outer handle. <Ref. to SL-23, REMOVAL, Front Outer Handle.>
- 9) Remove the front pillar lower trim to disconnect the connector from body harness.

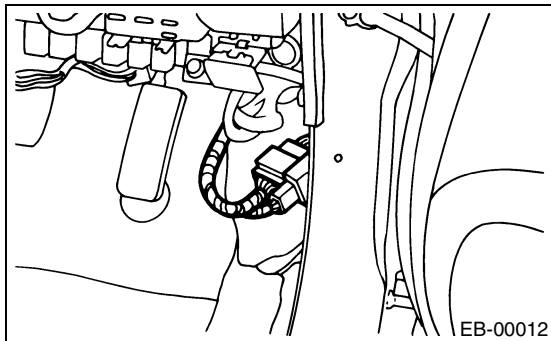

- 10) Put a wooden block on jack and place jack under door. Support the door with a jack to protect it from damage.

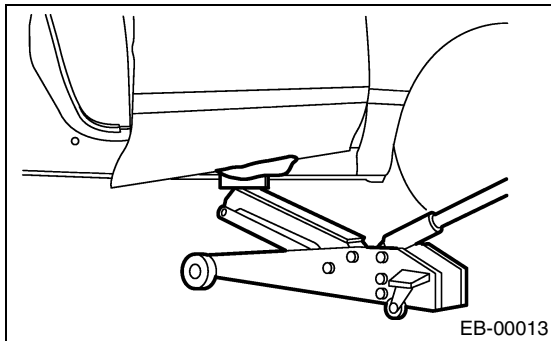

NOTE:

When supporting the door with a jack, be careful not to deform the door hinges while working.

- 11) Remove the checker bolts.

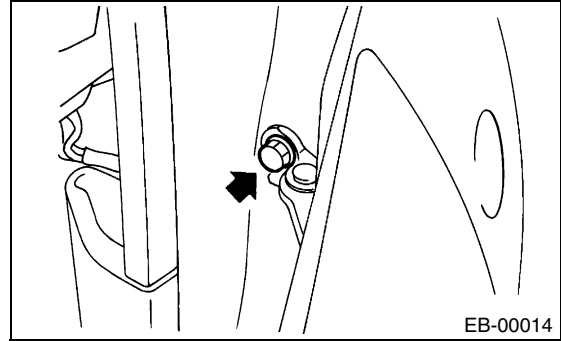

- 12) Remove the door-side bolts for upper and lower hinges to remove the door.

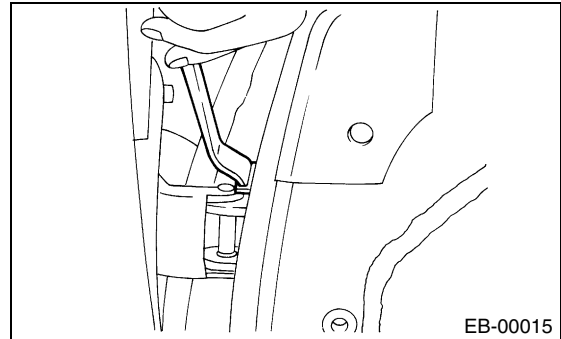

- 13) Using the ST, remove the body-side bolts for upper and lower hinges, and remove door hinges.
ST 925610000 DOOR HINGE WRENCH

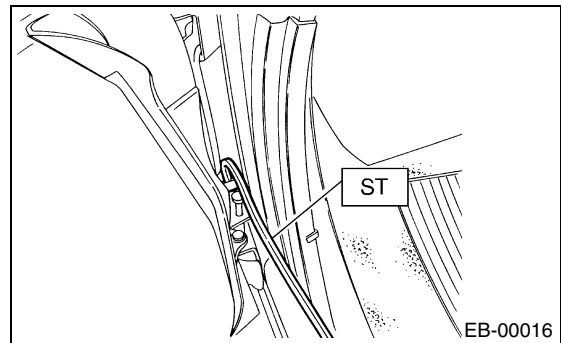

B: INSTALLATION

- 1) Install in the reverse order of removal.
- 2) Apply grease to the sliding area of door hinges.

FRONT DOOR PANEL

EXTERIOR BODY PANELS

C: ADJUSTMENT

1) Using the ST, loosen the body-side bolts of upper and lower hinges to align the position of front door panel longitudinally and vertically.

ST 925610000 DOOR HINGE WRENCH

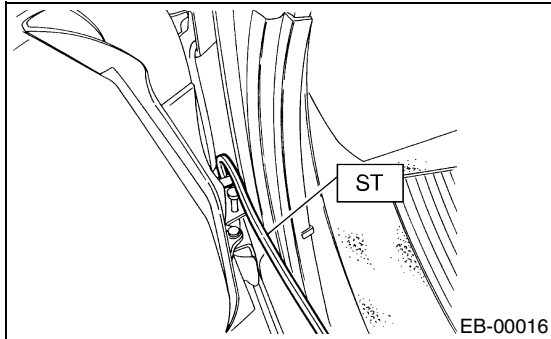

2) Loosen the door-side bolts of upper and lower hinges to align the position of front door panel vertically and laterally at the front end.

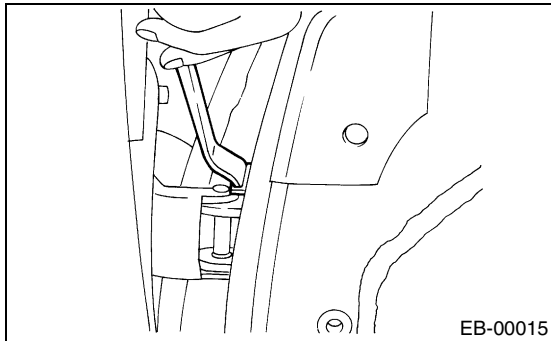

3) Loosen the screw (A) and lightly tap striker (B) using a plastic hammer to adjust striker to align the position of front door panel vertically and laterally at the rear end.

CAUTION:

Do not use an impact wrench. Welding area on the striker nut plate is easily broken.

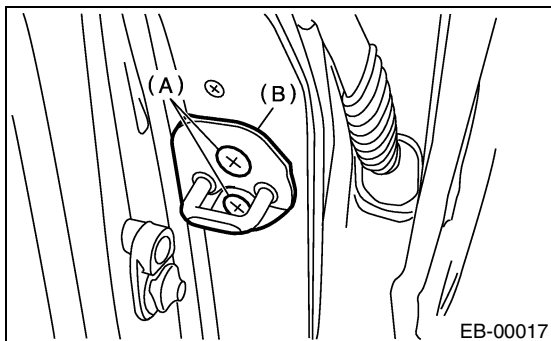

5. Front Sealing Cover

A: REMOVAL

- 1) Disconnect the ground cable from battery.
- 2) Remove the front door trim. <Ref. to EI-35, REMOVAL, Front Door Trim.>
- 3) Remove the front speaker. <Ref. to ET-6, REMOVAL, Front Speaker.>
- 4) Remove the door trim bracket.

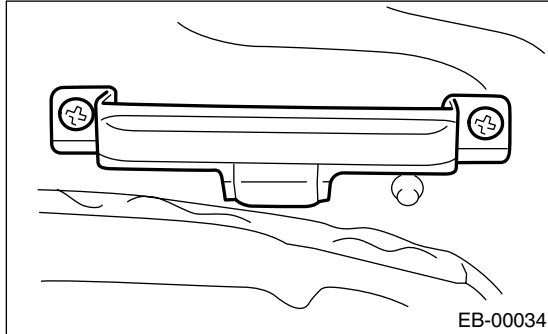

- 5) Remove the sealing cover.

NOTE:

- Carefully remove the butyl tape. Excessive force will easily break the cover.
- If the cover gets broken, replace it with a new one.

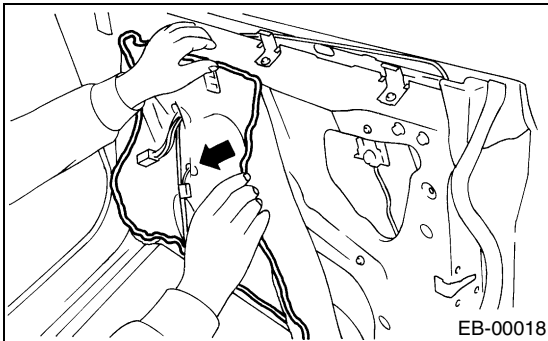

B: INSTALLATION

- 1) Install in the reverse order of removal.
- 2) When replacing the sealing cover, use butyl tape sealer.
- 3) Press the sealer-applied area firmly to prevent any floating on surface.

Butyl tape:

3M8626 or equivalent

NOTE:

- Apply a uniform bead of butyl tape.
- Attach the sealing cover, keeping it from becoming wrinkled.
- Breaks in the bead will allow water leakage and contamination.

C: INSPECTION

If the sealing cover is damaged, replace it with a new one.

REAR DOOR PANEL

EXTERIOR BODY PANELS

6. Rear Door Panel

A: REMOVAL

- 1) Disconnect the ground cable from battery.
- 2) Remove the rear door trim. <Ref. to EI-36, REMOVAL, Rear Door Trim.>
- 3) Remove the rear sealing cover. <Ref. to EB-16, REMOVAL, Rear Sealing Cover.>
- 4) Remove the rear door glass. <Ref. to GW-21, REMOVAL, Rear Door Glass.>
- 5) Remove the rear door regulator and motor assembly. <Ref. to GW-23, REMOVAL, Rear Regulator and Motor Assembly.>
- 6) Remove the rear door latch assembly. <Ref. to SL-28, REMOVAL, Rear Door Latch Assembly.>
- 7) Remove the rear outer handle. <Ref. to SL-27, REMOVAL, Rear Outer Handle.>
- 8) Remove the center pillar lower trim. <Ref. to EI-44, REMOVAL, Lower Inner Trim.>
- 9) Remove the seatbelt bracket and blind plug.
Disconnect the connector of door harness and remove the door hinge nut.

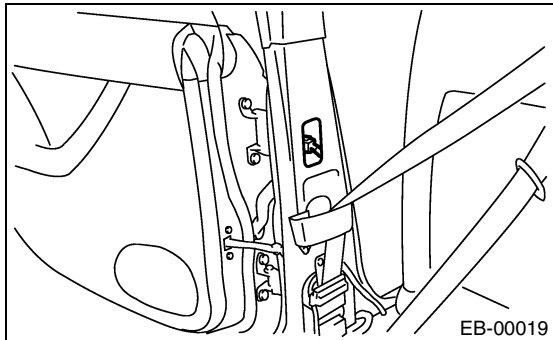

- 10) Put a wooden block on the jack and place the jack under the door. Support the door with the jack to protect it.

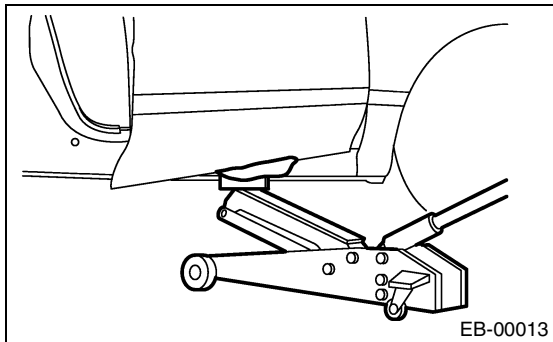

- 11) Remove the checker bolts.

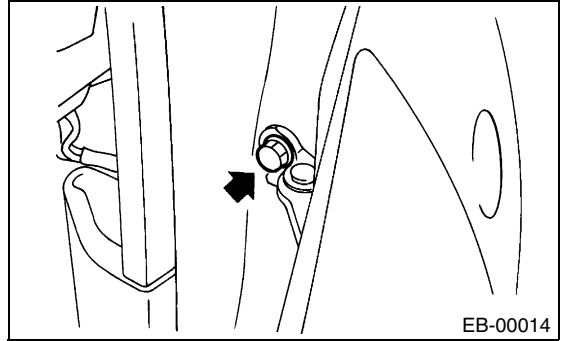

- 12) Remove the door-side bolts for upper and lower hinges to remove the door.

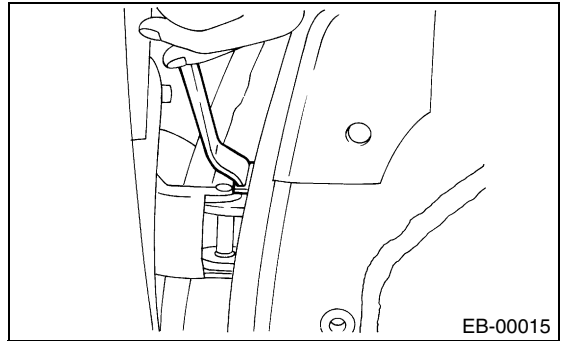

- 13) Using the ST, remove the body-side bolts for upper and lower hinges, and remove door hinges.

B: INSTALLATION

- 1) Install in the reverse order of removal.
- 2) Apply grease to the sliding area of door hinges.

C: ADJUSTMENT

- 1) Using the ST, loosen the body-side bolts of upper and lower hinges to align the position of rear door panel longitudinally and vertically.

ST 925610000 DOOR HINGE WRENCH

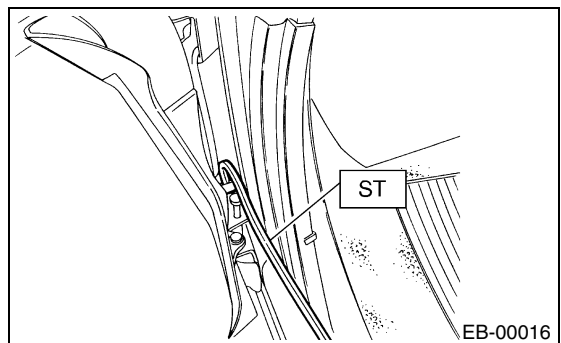

2) Loosen the door-side bolts of upper and lower hinges to align the position of rear door panel vertically and laterally at front-end.

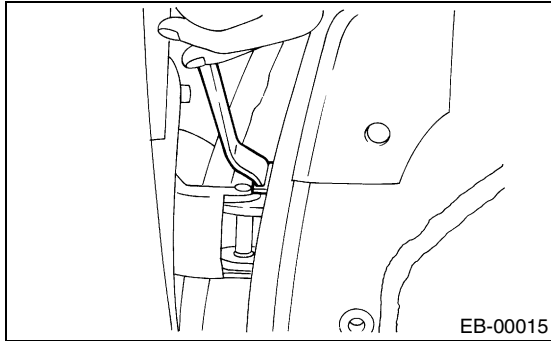

3) Loosen the screw (A) and lightly tap striker (B) using plastic hammer to adjust striker to align the position of front door panel vertically and laterally at the rear end.

CAUTION:

Do not use an impact wrench. The welding area on the striker nut plate is easily broken.

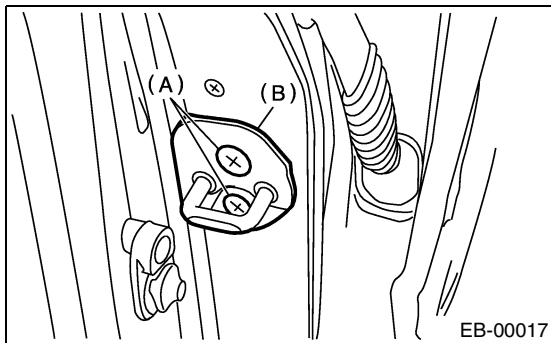

REAR SEALING COVER

EXTERIOR BODY PANELS

7. Rear Sealing Cover

A: REMOVAL

- 1) Disconnect the ground cable from battery.
- 2) Remove the rear door trim. <Ref. to EI-36, REMOVAL, Rear Door Trim.>
- 3) Remove the rear speaker. <Ref. to ET-7, REMOVAL, Rear Speaker.>
- 4) Remove the door trim bracket.

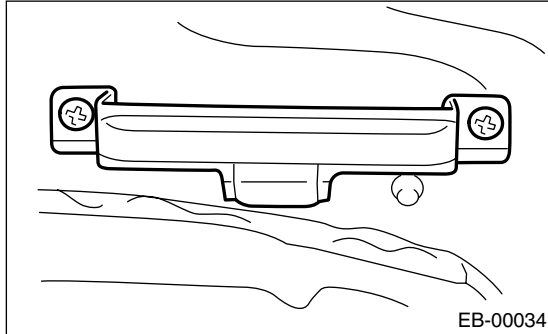

- 5) Remove the sealing cover.

NOTE:

- Carefully remove the butyl tape. Excessive force will easily break the cover.
- If the cover gets broken, replace it with a new one.

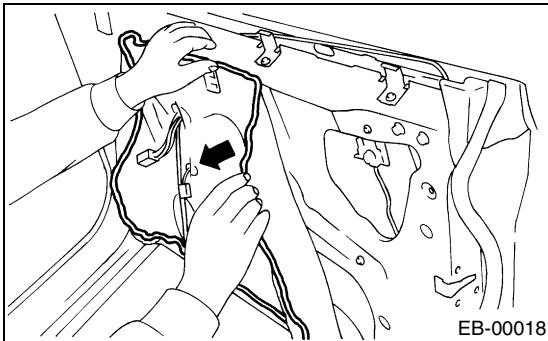

B: INSTALLATION

- 1) Install in the reverse order of removal.
- 2) When replacing the sealing cover, use butyl tape.
- 3) Press the sealer-applied area firmly to prevent any floating on surface.

Butyl tape:

3M8626 or equivalent

NOTE:

- Apply an uniform bead of butyl tape.
- Attach the sealing cover, keeping it from becoming wrinkled.
- Breaks in the bead will allow water leakage and contamination.

C: INSPECTION

If the sealing cover is damaged, replace it with a new one.

8. Rear Gate Panel

A: REMOVAL

1. REAR GATE PANEL

- 1) Disconnect the ground cable from battery.
- 2) Open the rear gate.
- 3) Remove the rear gate trim. <Ref. to EI-48, REMOVAL, Rear Gate Panel Trim.>
- 4) Remove the rear wiper motor. <Ref. to WW-17, REMOVAL, Rear Gate Garnish.>
- 5) Remove the rear gate outer handle. <Ref. to SL-30, REMOVAL, Rear Gate Outer Handle.>
- 6) Remove the rear gate garnish assembly. <Ref. to EB-20, REMOVAL, Rear Gate Garnish Assembly.>
- 7) Remove the rear gate latch assembly. <Ref. to SL-31, REMOVAL, Rear Gate Latch Assembly.>
- 8) Disconnect the connectors of rear wiper, rear defogger, and other lighting devices.
- 9) Disconnect the washer hose.
- 10) Remove the rubber duct (A) connection, and pull out the harness and washer hose from rear gate.

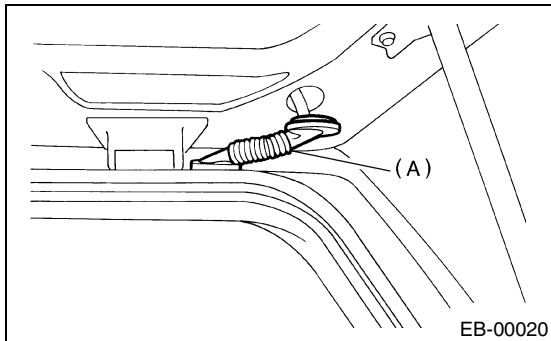

- 11) Using a support, support the rear gate while removing gas stay mounting bolts.

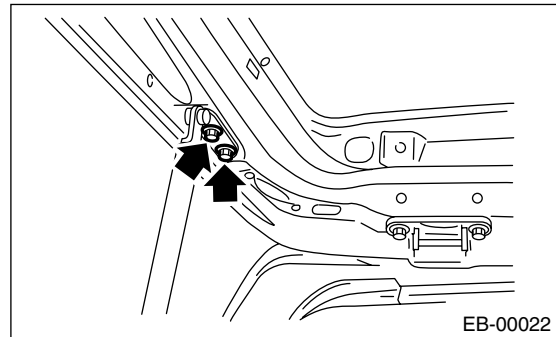
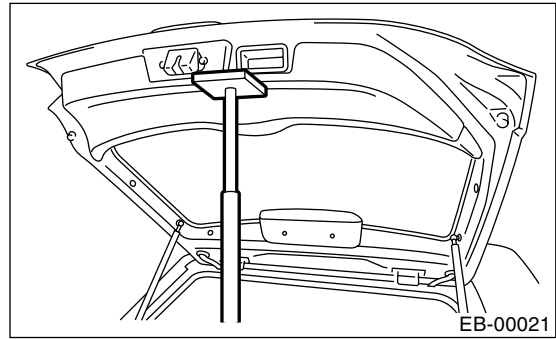

NOTE:

When the rear gate is released, it may hit and damage the body. To prevent this, place a shop cloth between the body and gate.

- 12) Loosen the rear gate bolts to remove rear gate.

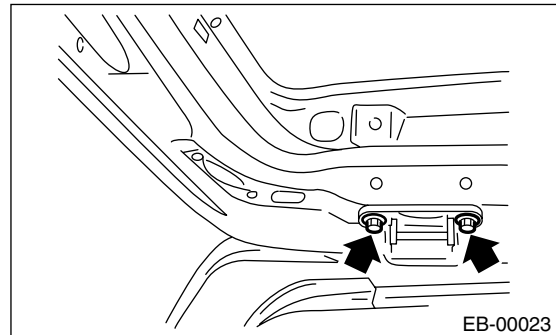

REAR GATE PANEL

EXTERIOR BODY PANELS

2. GAS STAY

1) Open the rear gate. Use a support jack to support the rear gate.

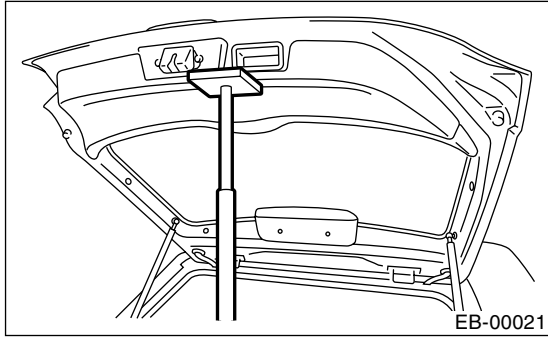

NOTE:

After the gas stay is removed, the rear gate cannot stay open. Supporting the rear gate with a jack, remove the bolts.

CAUTION:

- Do not damage the piston rods and oil seals.
- Never disassemble the cylinders: They contain gas.

2) Loosen the bolts to remove the gas stay from rear gate.

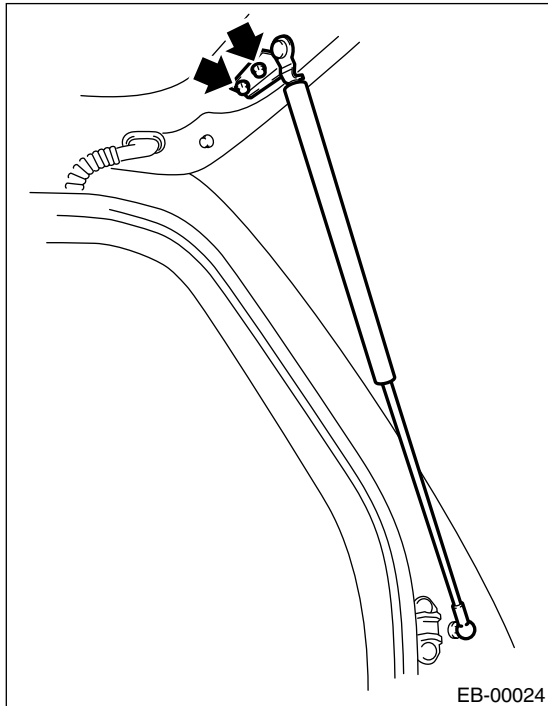

B: INSTALLATION

1. REAR GATE PANEL

1) Install in the reverse order of removal.

2) Install the rear gate panel with uniform clearance to the body.

Refer to COMPONENT of General Description for tightening torque. <Ref. to EB-7, REAR GATE PANEL, General Description.>

NOTE:

After supporting the rear gate with a jack, start working.

2. GAS STAY

1) Install the mounting bolt (A) to the body.

Tightening torque:

14 N·m (1.43 kgf-m, 10.3 ft-lb)

2) Tighten the bolts at upper side of gas stay.

Tightening torque:

7.5 N·m (0.76 kgf-m, 5.5 ft-lb)

3) Firmly install the gas stay (B) to mounting bolt (A).

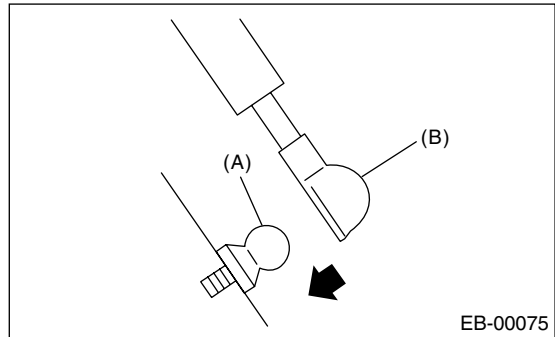

C: DISPOSAL

1. GAS STAY

CAUTION:

Gas is colorless, odorless, and harmless. However, gas pressure may spray cutting powder or oil. Be sure to wear dust-resistant goggles.

1) Cover with a vinyl case as shown in the figure.

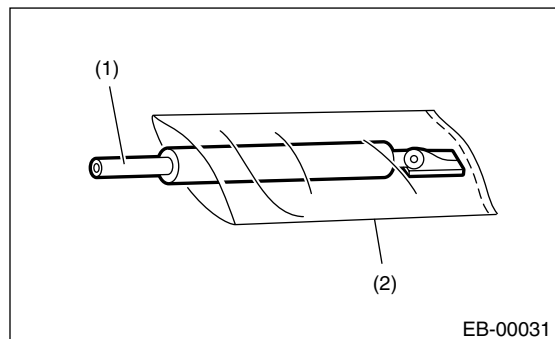

- (1) Gas stay
- (2) Vinyl sack

NOTE:

Prevent the vinyl case from being caught by drill cutting edge

2) Lift the body side slightly with piston rods fully extended, and secure the body side on vise stand. Drill a hole in 2 to 3 mm (0.08 to 0.12 in) diameter at a point 10 to 200 mm (0.39 to 7.87 in) from the door side, and bleed the gas stay completely.

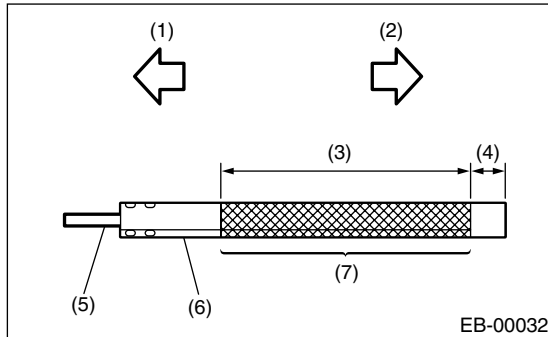

- (1) Body side
- (2) Door side
- (3) 190 mm (7.48 in)
- (4) 10 mm (0.39 in)
- (5) Piston rod
- (6) Cylinder
- (7) Portion to be drilled

REAR GATE GARNISH ASSEMBLY

EXTERIOR BODY PANELS

9. Rear Gate Garnish Assembly

A: REMOVAL

- 1) Remove the rear gate panel trim. <Ref. to EI-48, REMOVAL, Rear Gate Panel Trim.>
- 2) Remove the rear wiper motor. <Ref. to WW-17, REMOVAL, Rear Gate Garnish.>
- 3) Remove the seven frange nuts from inside of rear gate panel.
- 4) Remove the licence plate light assembly.
- 5) Close the gate, and then remove the rear gate garnish assembly, pulling it forward by hand.

NOTE:

Be careful not to pulling it forward by hand the rear gate garnish assembly strongly to avoid damage to clips.

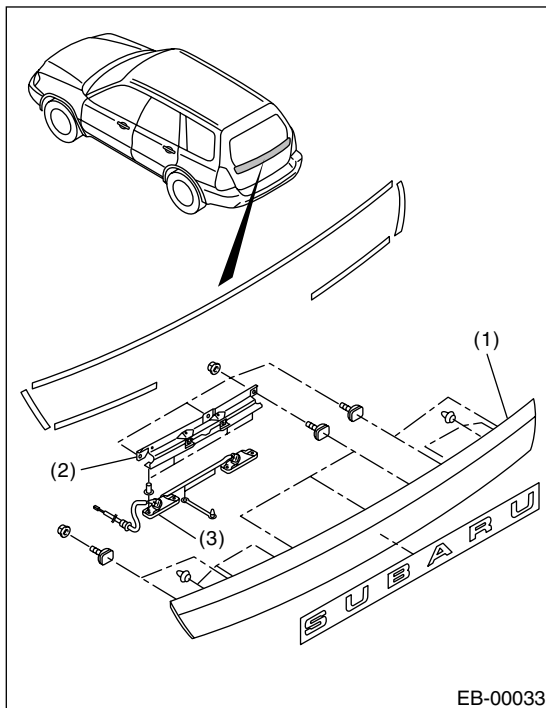

- (1) Rear gate garnish ASSY
- (2) Licence plate light bracket
- (3) Licence plate light

B: INSTALLATION

Install in the reverse order of removal.

C: INSPECTION

Check for serious scratches or cracks in rear gate garnish assembly.