

REAR SUSPENSION

RS

	Page
1. General Description	2
2. Wheel Alignment	9
3. Rear Stabilizer	10
4. Rear Trailing Link	11
5. Rear Strut	15
6. Lateral link	16
7. Rear Crossmember	19
8. General Diagnostic Table	20

GENERAL DESCRIPTION

REAR SUSPENSION

1. General Description

A: SPECIFICATIONS

Item	Non-turbo	Turbo
Camber (tolerance: $\pm 0^{\circ}45'$)	$-0^{\circ}50'$	$-0^{\circ}55'$
Toe-in	2 ± 3 mm (0.079 ± 0.118 in) Each toe-in angle: $0^{\circ}05' \pm 0^{\circ}07'30''$	
Wheel arch height (tolerance: $+12/-24$ mm ($+0.47/-0.94$ in))	440 mm (17.32 in)	435 mm (17.13 in)
Thrust angle	$0^{\circ} \pm 30'$	
Diameter of stabilizer	17 mm (0.67 in)	

NOTE:

- Front and rear toe-ins and front camber can be adjusted. If toe-in or camber tolerance exceeds specifications, adjust toe-in and camber to the middle value of specification.
- The other items indicated in the specification table cannot be adjusted. If the other items exceeds specifications, check suspension parts and connections for deformities; replace with new ones as required.

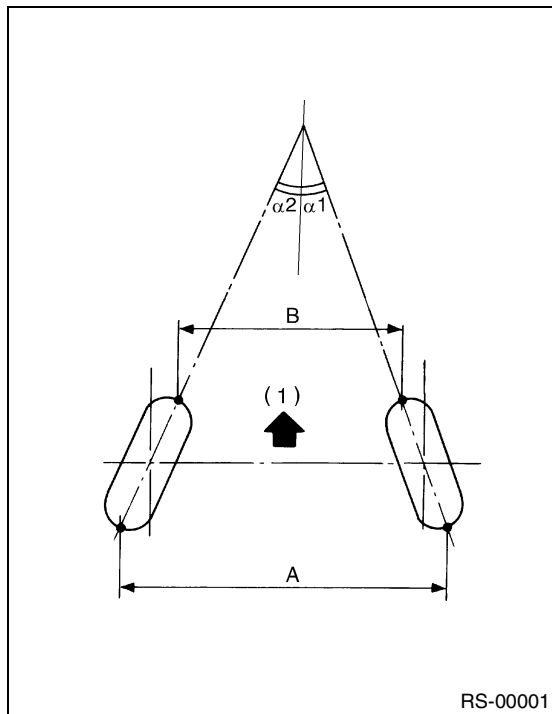

(1) Front

A - B = Positive: Toe-in, Negative: Toe-out

$\alpha 1, \alpha 2$: Each toe-in angle

B: COMPONENT

1. REAR SUSPENSION

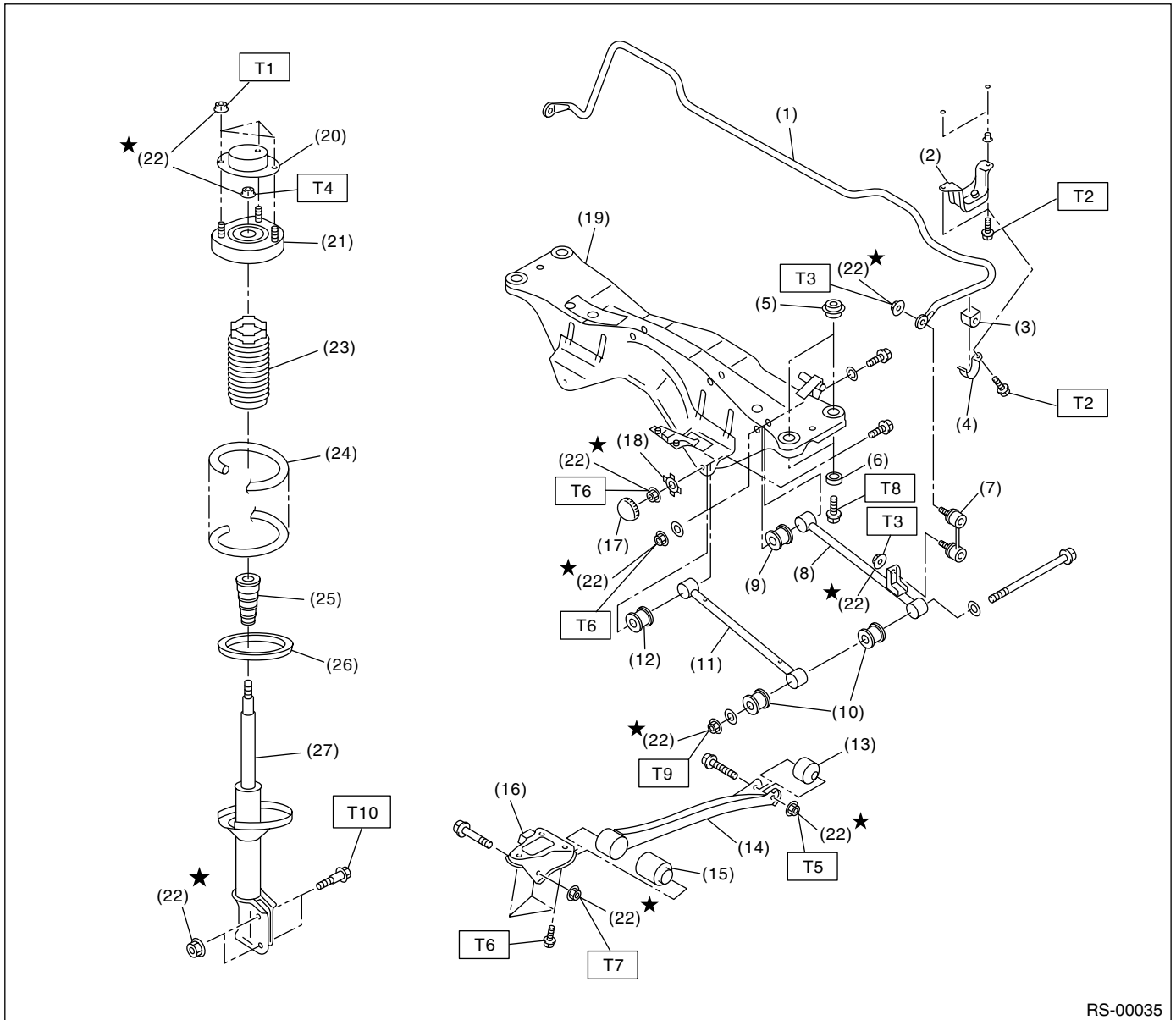

RS-00035

GENERAL DESCRIPTION

REAR SUSPENSION

(1) Stabilizer	(16) Trailing link bracket	<i>Tightening torque: N-m (kgf-m, ft-lb)</i>
(2) Stabilizer bracket	(17) Cap (Protection)	<i>T1: 20 (2.0, 14.5)</i>
(3) Stabilizer bushing	(18) Washer	<i>T2: 25 (2.5, 18.1)</i>
(4) Clamp	(19) Rear crossmember	<i>T3: 45 (4.6, 33.2)</i>
(5) Floating bushing	(20) Strut mount cap	<i>T4: 60 (6.1, 44)</i>
(6) Stopper	(21) Strut mount	<i>T5: 90 (9.2, 66)</i>
(7) Stabilizer link	(22) Self-locking nut	<i>T6: 100 (10.2, 74)</i>
(8) Rear lateral link	(23) Dust cover	<i>T7: 115 (11.7, 85)</i>
(9) Bushing (C)	(24) Coil spring	<i>T8: 130 (13.3, 96)</i>
(10) Bushing (A)	(25) Helper	<i>T9: 140 (14.3, 103)</i>
(11) Front lateral link	(26) Rubber seat lower	<i>T10: 200 (20.4, 148)</i>
(12) Bushing (B)	(27) Damper strut	
(13) Trailing link rear bushing		
(14) Trailing link		
(15) Trailing link front bushing		

C: CAUTION

- Wear working clothing, including a cap, protective goggles, and protective shoes during operation.
- Before disposing shock absorbers, be sure to bleed gas completely. Also, do not throw away in fire.
- Before removal, installation or disassembly, be sure to clarify the failure. Avoid unnecessary removal, installation, disassembly, and replacement.
- Use SUBARU genuine grease etc. or the equivalent. Do not mix grease etc. with that of another grade or from other manufacturers.
- Be sure to tighten fasteners including bolts and nuts to the specified torque.
- Place shop jacks or safety stands at the specified points.
- Before securing a part on a vise, place cushioning material such as wood blocks, aluminum plate, or shop cloth between the part and the vise.

GENERAL DESCRIPTION

REAR SUSPENSION

D: PREPARATION TOOL

1. SPECIAL TOOLS

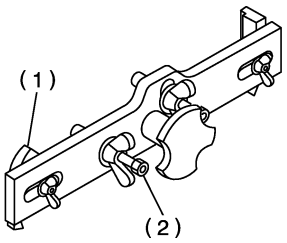
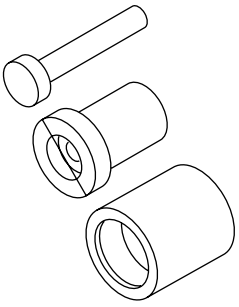
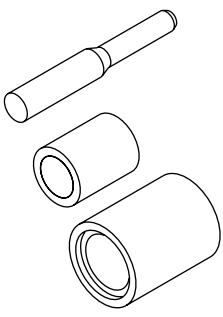
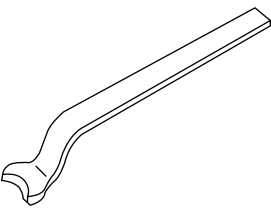
ILLUSTRATION	TOOL NUMBER	DESCRIPTION	REMARKS
 <p style="text-align: center;">ST-927380001</p>	927380001	ADAPTER	Used as an adapter for camber & caster gauge when measuring camber and caster. (1) 28199AC000 PLATE (2) 28199AC010 BOLT
 <p style="text-align: center;">ST-927720000</p>	927720000	INSTALLER & REMOVER	Used for replacing front bushing.
 <p style="text-align: center;">ST-927730000</p>	927730000	INSTALLER & REMOVER	Used for replacing rear bushing.
 <p style="text-align: center;">ST28099PA100</p>	28099PA100	REMOVER	Used for removing DOJ.

GENERAL DESCRIPTION

REAR SUSPENSION

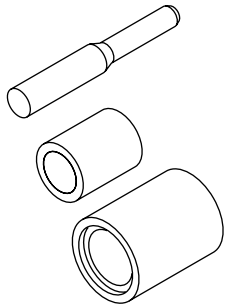
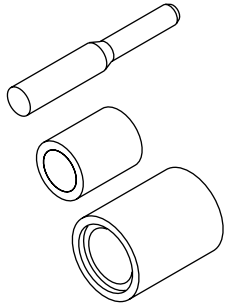
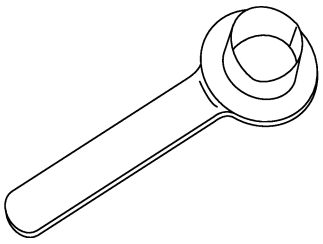
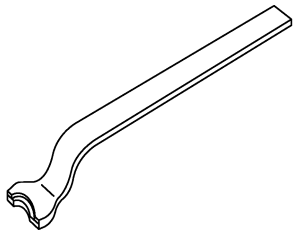
ILLUSTRATION	TOOL NUMBER	DESCRIPTION	REMARKS
 <p style="text-align: center;">ST-927700000</p>	927700000	INSTALLER & REMOVER	Used for replacing lateral link bushing.
 <p style="text-align: center;">ST-927690000</p>	927690000	INSTALLER & REMOVER	Used for replacing lateral link bushing.
 <p style="text-align: center;">ST28099PA090</p>	28099PA090	OIL SEAL PROTECTOR	<ul style="list-style-type: none"> • Used for installing rear drive shaft into rear differential. • For protecting oil seal.
 <p style="text-align: center;">ST28099PA100</p>	28099PA100	DRIVE SHAFT REMOVER	Used for removing rear drive shaft from rear differential.

GENERAL DESCRIPTION

REAR SUSPENSION

2. GENERAL PURPOSE TOOLS

TOOL NAME	REMARKS
Alignment gauge	Used for wheel alignment measurement.
Turning radius gauge	Used for wheel alignment measurement.
Toe-in gauge	Used for toe-in measurement.
Transmission jack	Used for suspension removal/installation.
Bearing puller	Used for removing bushings.
Coil spring compressor	Used for strut disassembly/assembly.

2. Wheel Alignment

A: INSPECTION

NOTE:

Measure and adjust the front and rear wheel alignment together. Follow the procedure in "FS" section "Wheel Alignment" for measurement and/or adjustment of wheel alignment. <Ref. to FS-7, INSPECTION, Wheel Alignment.>

REAR STABILIZER

REAR SUSPENSION

3. Rear Stabilizer

A: REMOVAL

- 1) Jack-up the rear part of the vehicle, support it with safety stands (rigid racks).
- 2) Remove the nut which secures stabilizer link to rear lateral link.

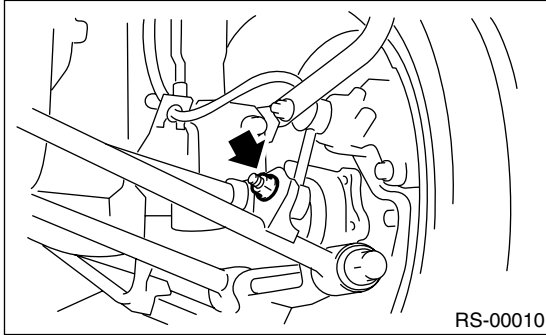

- 3) Remove the bolt which secures stabilizer to stabilizer bracket.

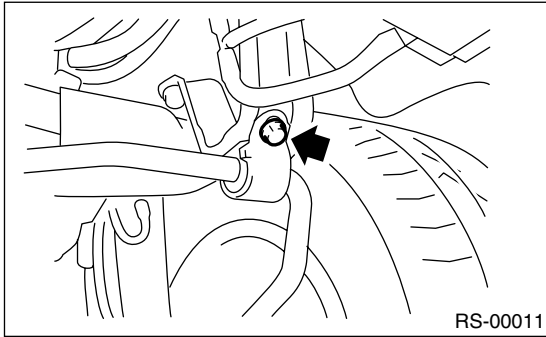

B: INSTALLATION

- 1) Install in the reverse order of removal.

NOTE:

- Install the bushing while aligning it with paint mark on stabilizer.
- Ensure that bushing and stabilizer have the same identification colors when installing.

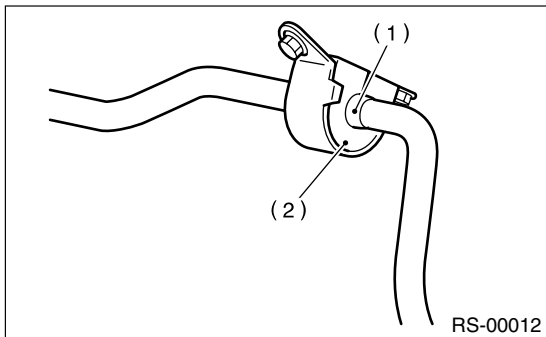

- (1) Mark stamped on stabilizer
- (2) Bushing identification color

- 2) Always tighten the rubber bushing location when wheels are in full contact with the ground and vehicle is curb weight.

Tightening torque:

Stabilizer link to rear lateral link

45 N·m (4.6 kgf-m, 33.2 ft-lb)

Stabilizer to stabilizer bracket

25 N·m (2.5 kgf-m, 18.1 ft-lb)

C: INSPECTION

- 1) Check the bushing for cracks, fatigue or damage.
- 2) Check the stabilizer link for deformities or damage.

4. Rear Trailing Link

A: REMOVAL

- 1) Loosen the rear wheel nuts.
- 2) Jack-up the vehicle, support it with safety stands (rigid racks), and then remove the rear wheels.
- 3) Remove both the rear parking brake clamp and ABS sensor harness.
- 4) Remove the bolt which secures trailing link to trailing link bracket.

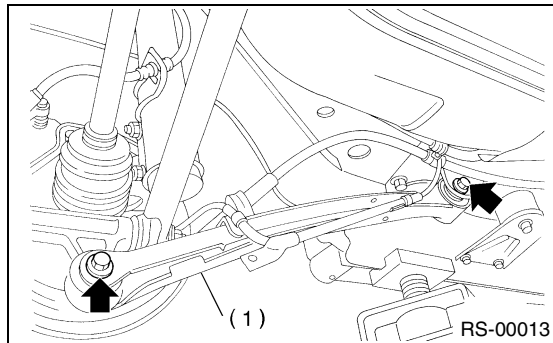

(1) Trailing link

- 5) Remove the bolt which secures trailing link to rear housing.

B: INSTALLATION

- 1) Install in the reverse order of removal.
- 2) Always tighten the rubber bushing location when wheels are in full contact with the ground and vehicle is at curb weight condition.

NOTE:

Check the wheel alignment and adjust if necessary.

C: DISASSEMBLY

1. FRONT BUSHING

Using the ST, press the front bushing out of place.
 ST 927720000 INSTALLER & REMOVER SET

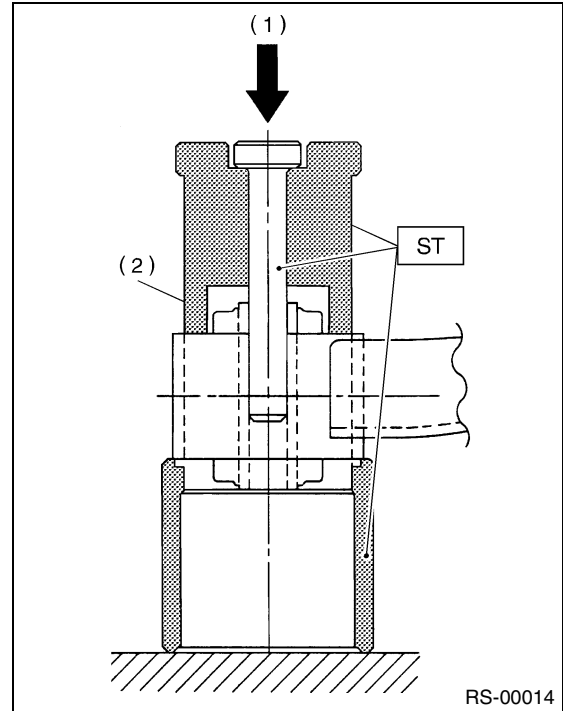

- (1) Press
- (2) Trailing link

REAR TRAILING LINK

REAR SUSPENSION

2. REAR BUSHING

- 1) Remove the housing. <Ref. to DS-23, REMOVAL, Rear Axle.>
- 2) Using the ST, press the rear bushing out of place.

ST 927730000 INSTALLER & REMOVER SET

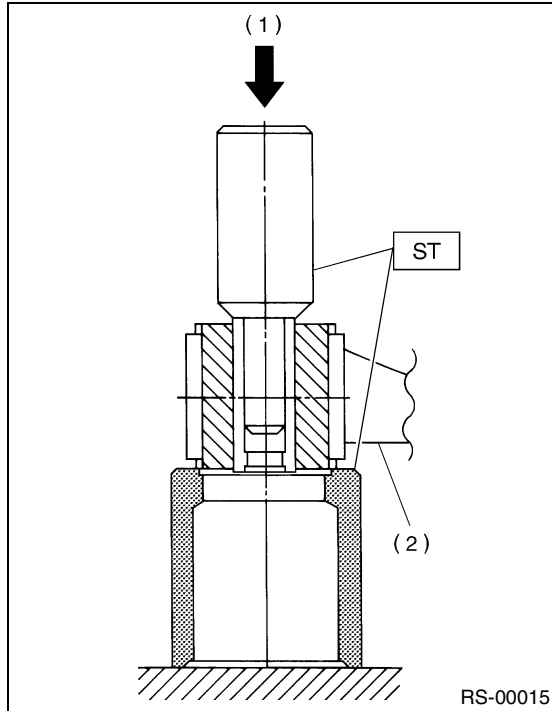

- (1) Press
- (2) Housing

D: ASSEMBLY

1. FRONT BUSHING

Using the ST, press the bushing into trailing link.
ST 927720000 INSTALLER & REMOVER SET

CAUTION:
Turn the ST plunger upside down and press it until the plunger end surface contacts trailing link end surface.

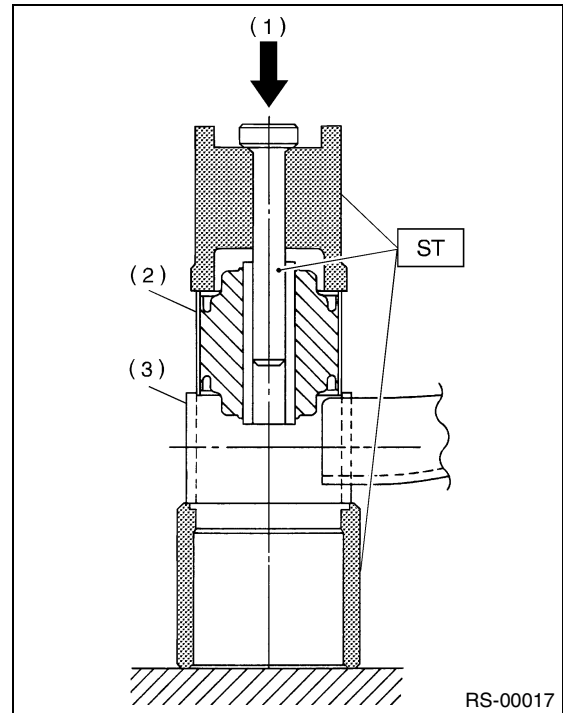

- (1) Press
- (2) Front bushing
- (3) Trailing link

2. REAR BUSHING

1) Using the ST, press the bushing into trailing link.
 ST 927730000 INSTALLER & REMOVER SET

NOTE:
 If it is difficult to press the bushing into trailing link, apply water-diluted TIRE LUBE to the inner surface of ST as a lubricant.

Specified lubricant:
TIRE LUBE: water = 1 : 3

2) Press the ST plunger until bushing flange protrudes beyond trailing link.
 ST 927730000 INSTALLER & REMOVER SET

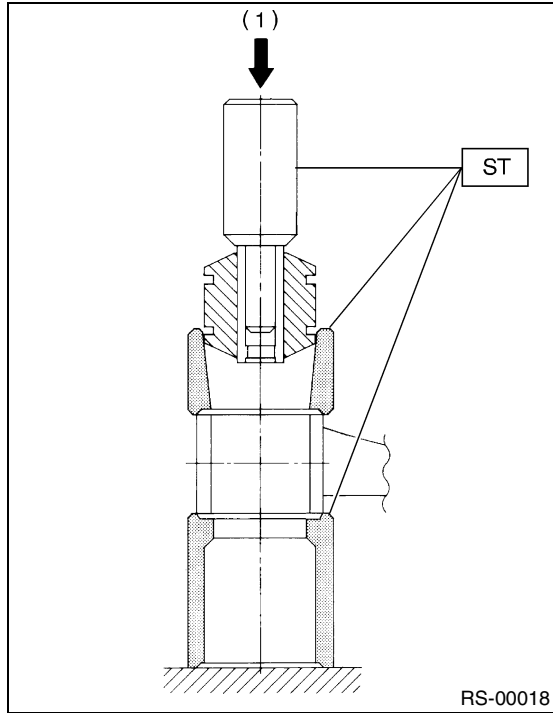

(1) Press

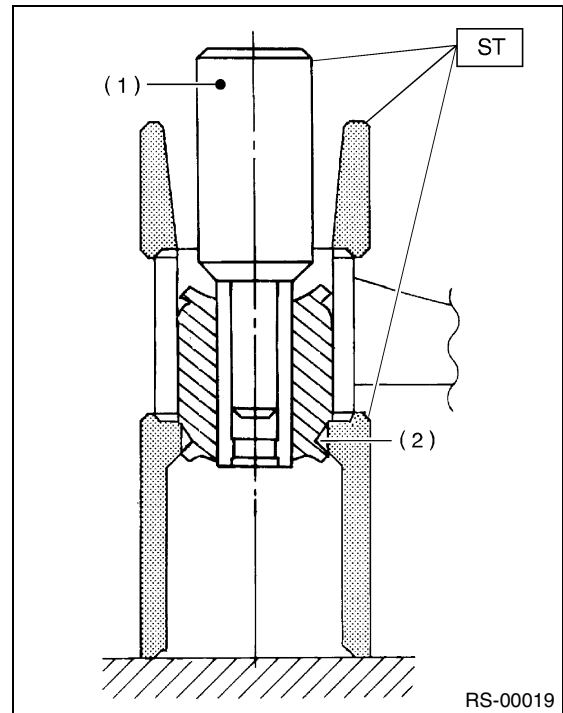

(1) Plunger
 (2) Flange

REAR TRAILING LINK

REAR SUSPENSION

3) Turn the trailing link upside down. Press the ST plunger in the opposite direction that outlines in the former procedure until bushing is correctly positioned in trailing link.

ST 927730000 INSTALLER & REMOVER SET

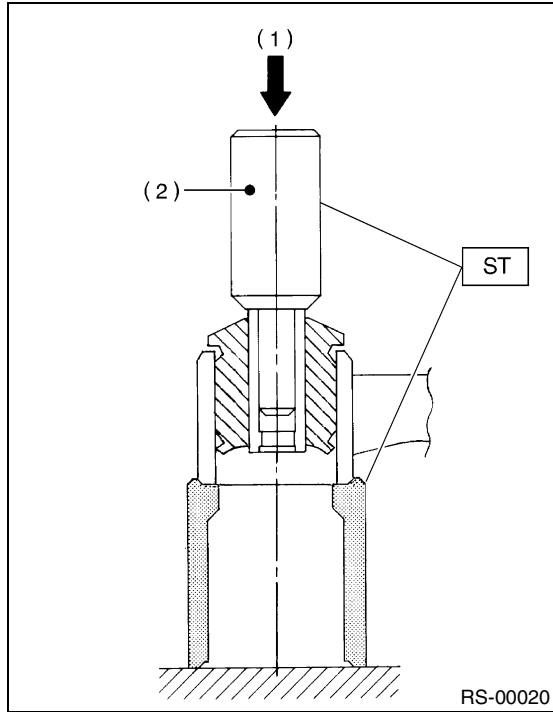

- (1) Press
- (2) Plunger

4) Install the housing. <Ref. to DS-26, INSTALLATION, Rear Axle.>

E: INSPECTION

Check the trailing links for bends, corrosion or damage.

5. Rear Strut

A: REMOVAL

- 1) Remove the strut cap of quarter trim.
- 2) Loosen the rear wheel nuts.
- 3) Jack-up the vehicle, support it with safety stands (rigid racks) and remove rear wheels.
- 4) Remove the brake hose clip, and then remove the brake hose from rear strut.

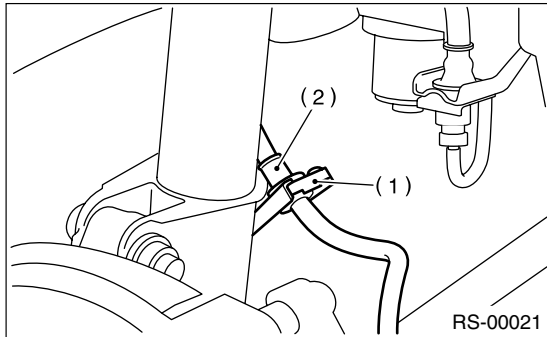

- (1) Brake hose clip
- (2) Brake hose

- 5) Remove the bolts which secure rear strut to housing.

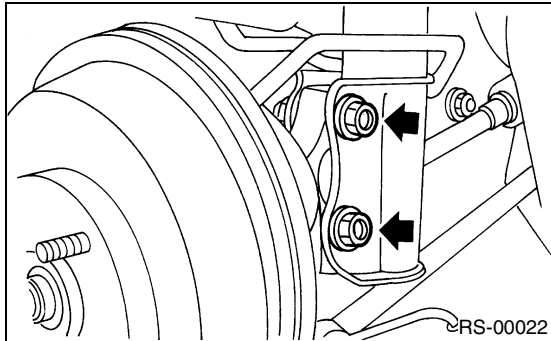

CAUTION:

Do not subject the brake hose and ABS sensor harness to excessive tension.

- 6) Remove the nuts securing strut mount to body.

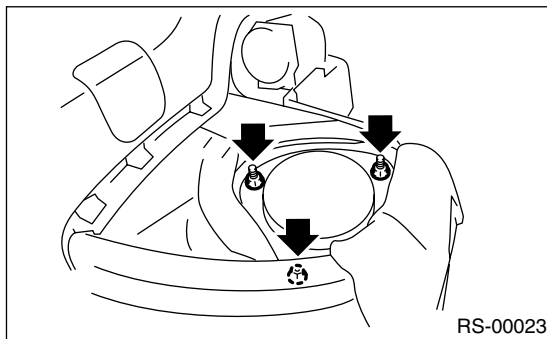

B: INSTALLATION

- 1) Secure the strut mount to body with a new self-locking nut. Tighten the self-locking nut used to secure strut mount to vehicle body.

Tightening torque:

20 N·m (2.0 kgf-m, 14.5 ft-lb)

- 2) Secure the rear strut to housing with a new self-locking nut.

Tightening torque:

200 N·m (20.4 kgf-m, 148 ft-lb)

- 3) Install the brake hose to lower side of strut, then insert brake hose clip.
- 4) Lower the vehicle and tighten wheel nut.

Tightening torque:

90 N·m (9.2 kgf-m, 66 ft-lb)

- 5) Install the strut cap to rear quarter trim.

NOTE:

Check the wheel alignment and adjust if necessary.

C: DISASSEMBLY

For disassembly of rear strut, refer to procedures outlined under front strut as a guide. <Ref. to FS-20, DISASSEMBLY, Front Strut.>

D: ASSEMBLY

Refer to Front Strut as a guide for assembly procedures.

<Ref. to FS-20, ASSEMBLY, Front Strut.>

E: INSPECTION

Refer to Front Strut as a guide for inspection procedures.

<Ref. to FS-21, INSPECTION, Front Strut.>

F: DISPOSAL

Refer to Front Strut as a guide for disposal procedures. <Ref. to FS-22, DISPOSAL, Front Strut.>

LATERAL LINK

REAR SUSPENSION

6. Lateral link

A: REMOVAL

- 1) Loosen the wheel nuts. Lift-up the vehicle and remove wheel.
- 2) Remove the stabilizers.
- 3) Remove the ABS sensor harness from trailing link.
- 4) Remove the bolt securing trailing link to housing.

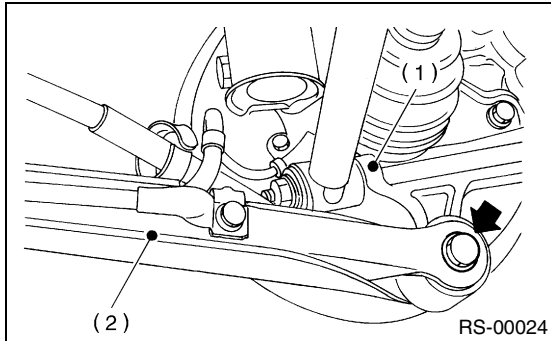

- (1) Rear housing
(2) Trailing link

- 5) Remove the bolts which secure lateral link assembly to rear housing.
- 6) Remove the DOJ from rear differential using ST. ST 28099PA100 DRIVE SHAFT REMOVER

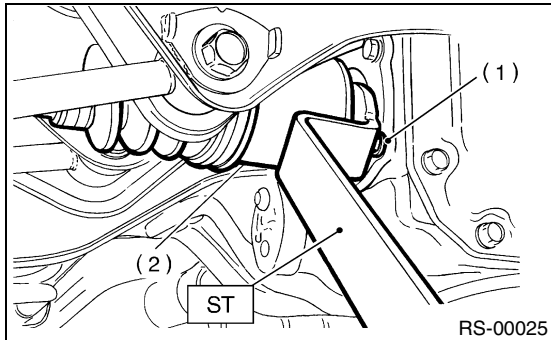

- (1) Bolt
(2) DOJ

CAUTION:

Be careful not to damage the side bearing retainer. Always use bolt shown in the figure, as supporting point for ST during removal.

- 7) Scribe an alignment mark on the rear lateral link adjusting bolt and crossmember.
- 8) Remove the bolts securing front and rear lateral links to crossmember, detach lateral links.

NOTE:

To loosen the adjusting bolt, always loosen the nut while holding head of adjusting bolt.

B: INSTALLATION

Install in the reverse order of removal. Observe the following instructions.

- Installation of DOJ to differential: <Ref. to DS-38, INSTALLATION, Rear Drive Shaft.>
- Always tighten the rubber bushing location when wheels are in full contact with the ground and vehicle is curb weight.
- Tighten the nut while holding bolt head when installing adjusting bolt.
- Replace the self-locking nut and DOJ circlip with new ones.

CAUTION:

Using the ST, do not allow the DOJ splines to damage side oil seal.

ST 28099PA090 OIL SEAL PROTECTOR

NOTE:

Check the wheel alignment and adjust if necessary.

C: DISASSEMBLY

- 1) Using the following table as a guide, verify the type of bushings.
- 2) Select the ST according to type of bushings used.

Bushing	ST: INSTALLER & REMOVER SET
Bushing A	927700000
Bushing B	927690000
Bushing C	927700000

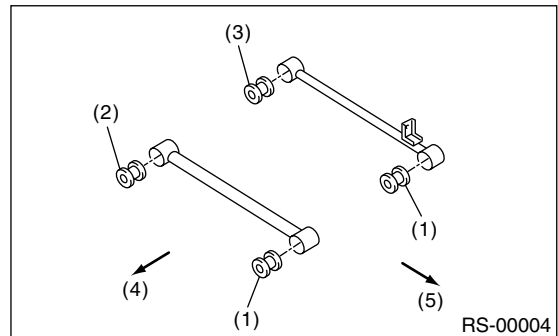

- (1) Bushing A
(2) Bushing B
(3) Bushing C
(4) Front
(5) Outside of body

3) Using the ST, press the bushing out of place.

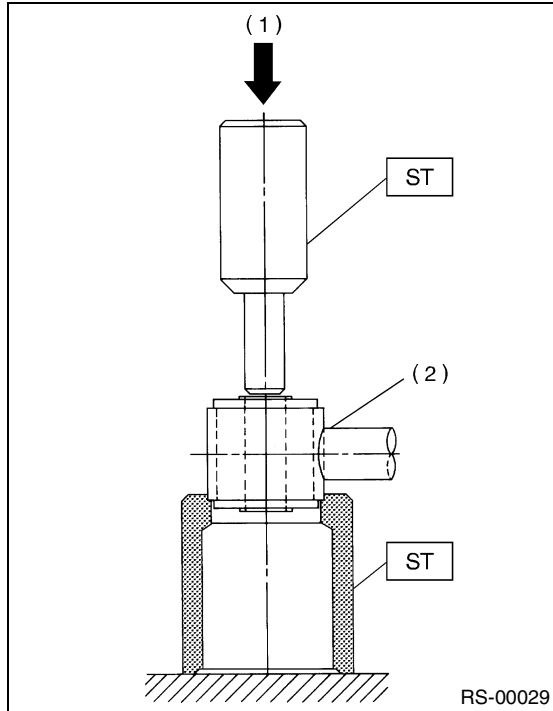

- (1) Press
- (2) Lateral link

D: ASSEMBLY

- 1) Using the same ST as that used during disassembly.
- 2) If it is difficult to press the bushing into trailing link, apply water-diluted TIRE LUBE to the inner surface of ST as a lubricant.

Specified lubricant:

TIRE LUBE: water = 1 : 3

3) Using the ST, press the bushing into place.

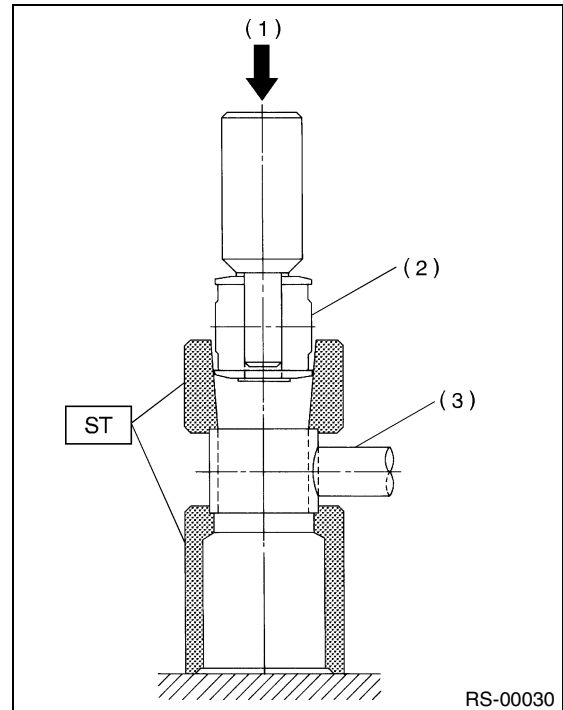

- (1) Press
- (2) Bushing
- (3) Lateral link

LATERAL LINK

REAR SUSPENSION

4) Press the ST plunger until bushing flange protrudes beyond lateral link.

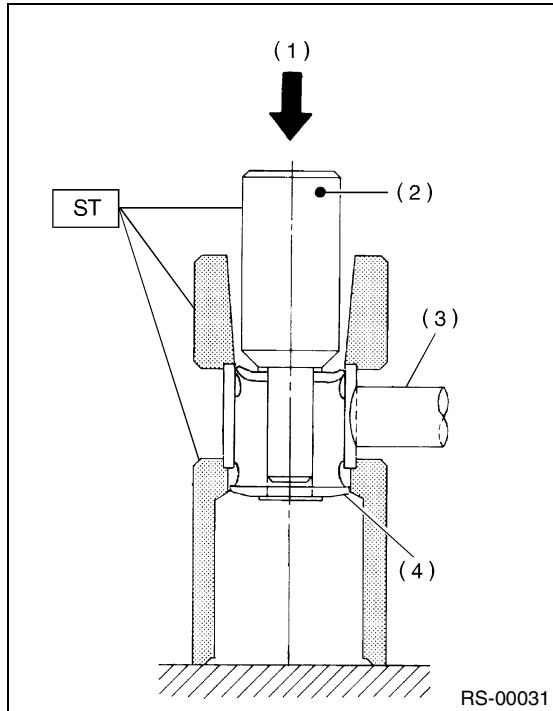

- (1) Press
- (2) Plunger
- (3) Lateral link
- (4) Flange

5) Turn the lateral link upside down. Press the ST plunger in opposite direction that outlined in the former procedure until bushing is correctly positioned in trailing link.

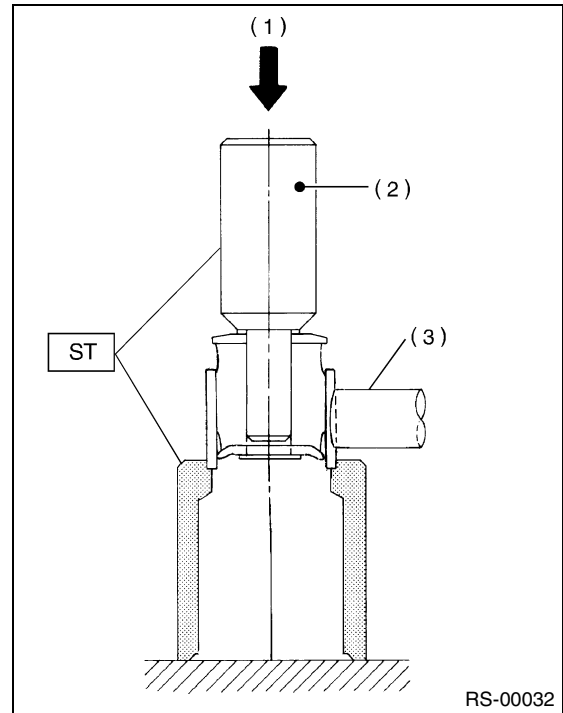

- (1) Press
- (2) Plunger
- (3) Lateral link

E: INSPECTION

Visually check the lateral links for damage or bends.

7. Rear Crossmember

A: REMOVAL

CAUTION:

Do not subject the ABS sensor harness to excessive tension.

- 1) Separate the front exhaust pipe and rear exhaust pipe.
- 2) Remove the rear exhaust pipe and muffler.
- 3) Remove the rear differential.
<Ref. to DI-24, REMOVAL, Rear Differential for T-type.>
- 4) Place the transmission jack under rear crossmember.

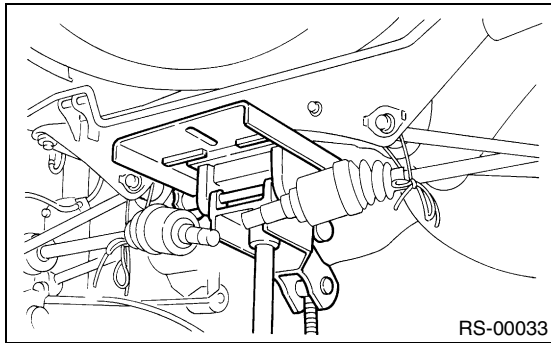

- 5) Remove the bolts securing crossmember to vehicle body, and then remove the crossmember.

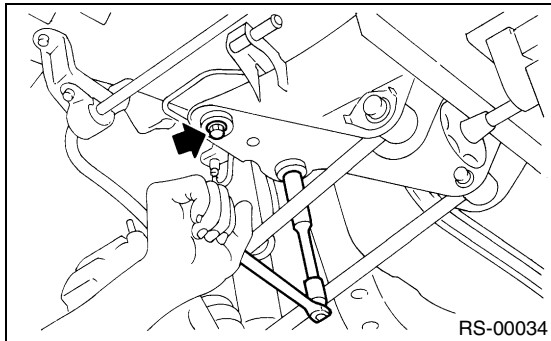

- 6) Scribe an alignment mark on the rear lateral link cam bolt and crossmember.
- 7) Remove the front and rear lateral links by loosening nuts.

B: INSTALLATION

- 1) Install in the reverse order of removal.

NOTE:

- Discard the loosened self-locking nut and replace it with a new one.
- Always tighten the nut (not adjusting bolt), when tightening adjusting bolt.

- 2) For installation and tightening torque of rear differential;

<Ref. to DI-26, INSTALLATION, Rear Differential for T-type.>

- 3) Always tighten the rubber bushing when wheels are in full contact with the ground and vehicle is curb weight.

NOTE:

Check the wheel alignment and adjust if necessary.

C: INSPECTION

Check the removed parts for wear, damage and cracks, and correct or replace if defective.

GENERAL DIAGNOSTIC TABLE

REAR SUSPENSION

8. General Diagnostic Table

A: INSPECTION

1. IMPROPER VEHICLE POSTURE OR IMPROPER WHEEL ARCH HEIGHT

Possible causes	Countermeasures
(1) Permanent distortion or breakage of coil spring	Replace.
(2) Unsmooth operation of damper strut and/or shock absorber	Replace.
(3) Installation of wrong strut and/or shock absorber	Replace with proper parts.
(4) Installation of wrong coil spring	Replace with proper parts.

2. POOR RIDE COMFORT

- 1) Large rebound shock
- 2) Rocking of the vehicle continues too long after running over bump and/or hump.
- 3) Large shock in bumping

Possible causes	Countermeasures
(1) Breakage of coil spring	Replace.
(2) Overinflation pressure of tire	Adjust.
(3) Improper wheel arch height	Adjust or replace the coil springs with new ones.
(4) Fault in operation of damper strut and/or shock absorber	Replace.
(5) Damage or deformation of strut mount and/or shock absorber mount	Replace.
(6) Unsuitable installation (maximum and/or minimum length) of damper strut and/or shock absorber	Replace with proper parts.
(7) Deformation or damage of bushing	Replace.
(8) Deformation or damage of helper in strut assembly and/or shock absorber	Replace.
(9) Oil leakage of damper strut and/or shock absorber	Replace.

3. NOISE

Possible causes	Countermeasures
(1) Wear or damage of damper strut and/or shock absorber component parts	Replace.
(2) Loosening of suspension link installing bolt	Retighten to the specified torque.
(3) Deformation or loss of bushing	Replace.
(4) Unsuitability of maximum and/or minimum length of damper strut and/or shock absorber	Replace with proper parts.
(5) Breakage of coil spring	Replace.
(6) Wear or damage of ball joint	Replace.
(7) Deformation of stabilizer clamp	Replace.