

# ENGINE (DIAGNOSTICS)

# *EN(SOHC)*

---

	<b>Page</b>
1. Basic Diagnostic Procedure .....	2
2. Check List for Interview .....	4
3. General Description .....	6
4. Electrical Components Location.....	9
5. Engine Control Module (ECM) I/O Signal .....	22
6. Engine Condition Data .....	25
7. Transmission Control Module (TCM) I/O Signal .....	26
8. Data Link Connector .....	29
9. OBD-II General Scan Tool .....	30
10. Subaru Select Monitor.....	32
11. Read Diagnostic Trouble Code .....	39
12. Inspection Mode .....	40
13. Drive Cycle .....	45
14. Clear Memory Mode.....	47
15. Compulsory Valve Operation Check Mode .....	48
16. Engine Malfunction Indicator Lamp (MIL) .....	50
17. Diagnostics for Engine Starting Failure.....	60
18. List of Diagnostic Trouble Code (DTC) .....	75
19. Diagnostic Procedure with Diagnostic Trouble Code (DTC) .....	81
20. General Diagnostic Table.....	261

# BASIC DIAGNOSTIC PROCEDURE

ENGINE (DIAGNOSTICS)

## 1. Basic Diagnostic Procedure

### A: PROCEDURE

#### 1. ENGINE

Step	Check	Yes	No
<b>1 CHECK ENGINE START FAILURE.</b> 1)Ask the customer when and how the trouble occurred using the interview check list. <Ref. to EN(SOHC)-4, CHECK, Check List for Interview.> 2)Start the engine. Does the engine start?	Engine starts.	Go to step 2.	Inspection using "Diagnostics for Engine Start Failure". <Ref. to EN(SOHC)-60, Diagnostics for Engine Starting Failure.>
<b>2 CHECK ILLUMINATION OF CHECK ENGINE MALFUNCTION INDICATOR LAMP (MIL).</b> Does CHECK ENGINE malfunction indicator lamp illuminate?	CHECK ENGINE malfunction indicator light illuminates.	Go to step 3.	Inspection using "General Diagnostics Table". <Ref. to EN(SOHC)-261, INSPECTION, General Diagnostic Table.>
<b>3 CHECK INDICATION OF DTC ON DISPLAY.</b> 1)Turn the ignition switch to OFF. 2)Connect the Subaru Select Monitor or the OBD-II general scan tool to data link connector. 3)Turn the ignition switch to ON and the Subaru Select Monitor or OBD-II general scan tool switch to ON. 4)Read the DTC on the Subaru Select Monitor or OBD-II general scan tool. Does the Subaru Select Monitor or OBD-II general scan tool indicate DTC?	DTC is indicated.	Record the diagnostic trouble code. Repair the trouble cause. <Ref. to EN(SOHC)-75, List of Diagnostic Trouble Code (DTC).> Go to step 4.	Repair the related parts. <b>NOTE:</b> If DTC is not shown on display although the MIL illuminates, perform diagnostics of MIL (CHECK ENGINE malfunction indicator lamp) circuit or combination meter. <Ref. to EN(SOHC)-50, Engine Malfunction Indicator Lamp (MIL).>
<b>4 PERFORM THE DIAGNOSIS.</b> 1)Perform the clear memory mode. <Ref. to EN(SOHC)-47, Clear Memory Mode.> 2)Perform the inspection mode. <Ref. to EN(SOHC)-40, Inspection Mode.> Does the Subaru Select Monitor or OBD-II general scan tool indicate DTC?	DTC is indicated.	Inspect using "Diagnostics Procedure with Diagnostic Trouble Code (DTC)". <Ref. to EN(SOHC)-81, Diagnostic Procedure with Diagnostic Trouble Code (DTC).>	Complete the diagnosis.

## 2. AUTOMATIC TRANSMISSION

When the trouble code about automatic transmission is shown on display, carry out the following basic check. After that, carry out the replacement or repair work.

- 1) ATF level check <Ref. to AT-29, Automatic Transmission Fluid.>
- 2) Differential gear oil level check <Ref. to AT-30, Differential Gear Oil.>
- 3) ATF leak check <Ref. to AT-29, Automatic Transmission Fluid.>
- 4) Differential gear oil leak check <Ref. to AT-30, Differential Gear Oil.>
- 5) Stall test <Ref. to AT-32, Stall Test.>
- 6) Line pressure test <Ref. to AT-35, Line Pressure Test.>
- 7) Transfer clutch pressure test <Ref. to AT-37, Transfer Clutch Pressure Test.>
- 8) Time lag test <Ref. to AT-34, Time Lag Test.>
- 9) Road test <Ref. to AT-31, Road Test.>
- 10) Shift characteristics <Ref. to AT-37, Transfer Clutch Pressure Test.>

# CHECK LIST FOR INTERVIEW

ENGINE (DIAGNOSTICS)

## 2. Check List for Interview

### A: CHECK

#### 1. CHECK LIST NO. 1

Check the following items when problem has occurred.

NOTE:

Use copies of this page for interviewing customers.

Customer's name		Engine no.	
Date of sale		Fuel brand	
Date of repair		Odometer reading	km
Vin no.			miles
Weather	<input type="checkbox"/> Fine <input type="checkbox"/> Cloudy <input type="checkbox"/> Rainy <input type="checkbox"/> Snowy <input type="checkbox"/> Various/Others:		
Outdoor temperature	°C (°F)		
	<input type="checkbox"/> Hot <input type="checkbox"/> Warm <input type="checkbox"/> Cool <input type="checkbox"/> Cold		
Place	<input type="checkbox"/> Highway <input type="checkbox"/> Suburbs <input type="checkbox"/> Inner city <input type="checkbox"/> Uphill <input type="checkbox"/> Downhill <input type="checkbox"/> Rough road <input type="checkbox"/> Others:		
	<input type="checkbox"/> Cold <input type="checkbox"/> Warming-up <input type="checkbox"/> After warming-up <input type="checkbox"/> Any temperature <input type="checkbox"/> Others:		
Engine speed	rpm		
Vehicle speed	MPH		
Driving conditions	<input type="checkbox"/> Not affected <input type="checkbox"/> At starting <input type="checkbox"/> While idling <input type="checkbox"/> At racing <input type="checkbox"/> While accelerating <input type="checkbox"/> While cruising <input type="checkbox"/> While decelerating <input type="checkbox"/> While turning (RH/LH)		
	<input type="checkbox"/> ON/ <input type="checkbox"/> OFF		
Headlight	<input type="checkbox"/> ON/ <input type="checkbox"/> OFF	Rear defogger	<input type="checkbox"/> ON/ <input type="checkbox"/> OFF
Blower	<input type="checkbox"/> ON/ <input type="checkbox"/> OFF	Radio	<input type="checkbox"/> ON/ <input type="checkbox"/> OFF
A/C compressor	<input type="checkbox"/> ON/ <input type="checkbox"/> OFF	CD/Cassette	<input type="checkbox"/> ON/ <input type="checkbox"/> OFF
Cooling fan	<input type="checkbox"/> ON/ <input type="checkbox"/> OFF	Car phone	<input type="checkbox"/> ON/ <input type="checkbox"/> OFF
Front wiper	<input type="checkbox"/> ON/ <input type="checkbox"/> OFF	CB	<input type="checkbox"/> ON/ <input type="checkbox"/> OFF
Rear wiper	<input type="checkbox"/> ON/ <input type="checkbox"/> OFF		

# CHECK LIST FOR INTERVIEW

ENGINE (DIAGNOSTICS)

## 2. CHECK LIST NO. 2

Check the following items about the vehicle's state when MIL turns on.

NOTE:

Use copies of this page for interviewing customers.

a) Other warning lights or indicators turn on. <input type="checkbox"/> Yes/ <input type="checkbox"/> No
<input type="checkbox"/> Low fuel warning light <input type="checkbox"/> Charge indicator light <input type="checkbox"/> AT diagnostics indicator light <input type="checkbox"/> ABS warning light <input type="checkbox"/> Engine oil pressure warning light
b) Fuel level
<ul style="list-style-type: none"><li>• Lack of gasoline: <input type="checkbox"/> Yes/<input type="checkbox"/> No</li><li>• Indicator position of fuel gauge:</li></ul>
c) Intentional connecting or disconnecting of harness connectors or spark plug cords: <input type="checkbox"/> Yes/ <input type="checkbox"/> No
<ul style="list-style-type: none"><li>• What:</li></ul>
d) Intentional connecting or disconnecting of hoses: <input type="checkbox"/> Yes/ <input type="checkbox"/> No
<ul style="list-style-type: none"><li>• What:</li></ul>
e) Installing of parts other than genuine parts: <input type="checkbox"/> Yes/ <input type="checkbox"/> No
<ul style="list-style-type: none"><li>• What:</li><li>• Where:</li></ul>
f) Occurrence of noise: <input type="checkbox"/> Yes/ <input type="checkbox"/> No
<ul style="list-style-type: none"><li>• From where:</li><li>• What kind:</li></ul>
g) Occurrence of smell: <input type="checkbox"/> Yes/ <input type="checkbox"/> No
<ul style="list-style-type: none"><li>• From where:</li><li>• What kind:</li></ul>
h) Intrusion of water into engine compartment or passenger compartment: <input type="checkbox"/> Yes/ <input type="checkbox"/> No
i) Troubles occurred
<input type="checkbox"/> Engine does not start. <input type="checkbox"/> Engine stalls during idling. <input type="checkbox"/> Engine stalls while driving. <input type="checkbox"/> Engine speed decreases. <input type="checkbox"/> Engine speed does not decrease. <input type="checkbox"/> Rough idling <input type="checkbox"/> Poor acceleration <input type="checkbox"/> Back fire <input type="checkbox"/> After fire <input type="checkbox"/> No shift <input type="checkbox"/> Excessive shift shock

# GENERAL DESCRIPTION

## ENGINE (DIAGNOSTICS)

### 3. General Description

#### A: CAUTION

1) Airbag system wiring harness is routed near the engine control module (ECM), main relay and fuel pump relay.

#### CAUTION:

- All Airbag system wiring harness and connectors are colored yellow. Do not use electrical test equipment on these circuit.

- Be careful not to damage the Airbag system wiring harness when servicing the engine control module (ECM), transmission control module (TCM), main relay and fuel pump relay.

2) Never connect the battery in reverse polarity.

- The ECM will be destroyed instantly.
- The fuel injector and other part will be damaged in just a few minutes more.

3) Do not disconnect the battery terminals while the engine is running.

- A large counter electromotive force will be generated in the generator, and this voltage may damage electronic parts such as ECM, etc.

4) Before disconnecting the connectors of each sensor and the ECM, be sure to turn OFF the ignition switch.

5) Poor contact has been identified as a primary cause of this problem. To measure the voltage and/or resistance of individual sensors or all electrical control modules at the harness side connector, use a tapered pin with a diameter of less than 0.64 mm (0.025 in). Do not insert the pin more than 5 mm (0.20 in) into the part.

6) Before removing the ECM from the located position, disconnect two cables on battery.

- Otherwise, the ECM may be damaged.

#### CAUTION:

**When replacing the ECM, be careful not to use the wrong spec. ECM to avoid any damage on fuel injection system.**

7) The connectors to each sensor in the engine compartment and the harness connectors on the engine side and body side are all designed to be waterproof. However, it is still necessary to take care not to allow water to get into the connectors when washing the vehicle, or when servicing the vehicle on a rainy day.

8) Use ECM mounting stud bolts at the body head grounding point when measuring voltage and resistance inside the passenger compartment.

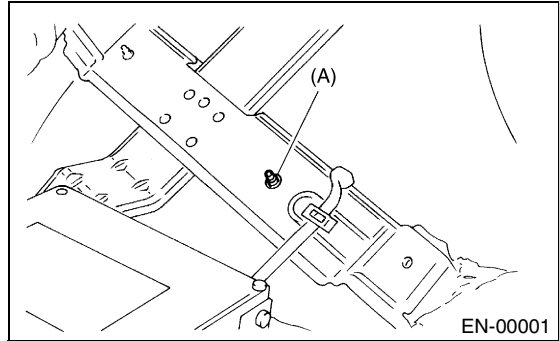

(A) Stud bolt

9) Use engine grounding terminal or engine proper as the grounding point to the body when measuring voltage and resistance in the engine compartment.

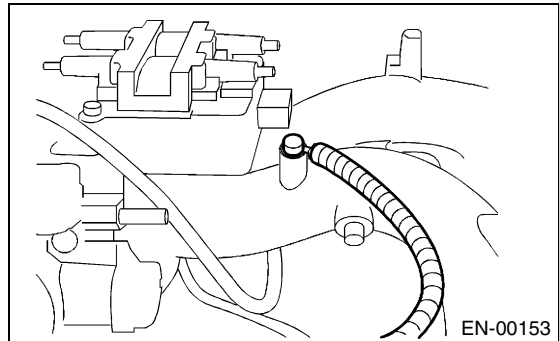

10) Use TCM mounting stud bolts at the body head grounding point when measuring voltage and resistance inside the passenger compartment.

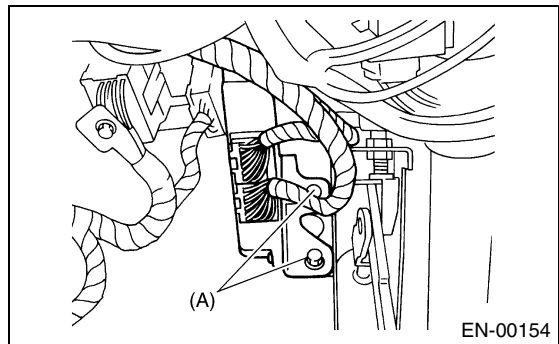

(A) Stud bolt

11) Every MFI-related part is a precision part. Do not drop them.

12) Observe the following cautions when installing a radio in MFI equipped models.

### CAUTION:

- The antenna must be kept as far apart as possible from the control unit.  
(The ECM is located under the steering column, inside of the instrument panel lower trim panel.)
- The antenna feeder must be placed as far apart as possible from the ECM and MFI harness.
- Carefully adjust the antenna for correct matching.
- When mounting a large power type radio, pay special attention to the three items above mentioned.
- Incorrect installation of the radio may affect the operation of the ECM.

13) Before disconnecting the fuel hose, disconnect the fuel pump connector and crank the engine for more than five seconds to release pressure in the fuel system. If engine starts during this operation, run it until it stops.

14) Problems in the electronic-controlled automatic transmission may be caused by failure of the engine, the electronic control system, the transmission proper, or by a combination of these. These three causes must be distinguished clearly when performing diagnostics.

15) Diagnostics should be conducted by rotating with simple, easy operations and proceeding to complicated, difficult operations. The most important thing in diagnostics is to understand the customer's complaint, and distinguish between the three causes.

16) In AT vehicles, do not continue the stall for more than five seconds at a time (from closed throttle, fully open throttle to stall engine speed).

17) On ABS vehicle, when performing driving test in jacked-up or lifted-up position, sometimes the warning light may be lit, but this is not a malfunction of the system. The reason for this is the speed difference between the front and rear wheels. After diagnosis of engine control system, perform the ABS memory clearance procedure of self-diagnosis system.

## B: INSPECTION

Before performing diagnostics, check the following items which might affect engine problems:

### 1. BATTERY

1) Measure battery voltage and specific gravity of electrolyte.

**Standard voltage: 12 V**

**Specific gravity: Above 1.260**

2) Check the condition of the main and other fuses, and harnesses and connectors. Also check for proper grounding.

### 2. ENGINE GROUNDING

Make sure the engine grounding terminal is properly connected to the engine.

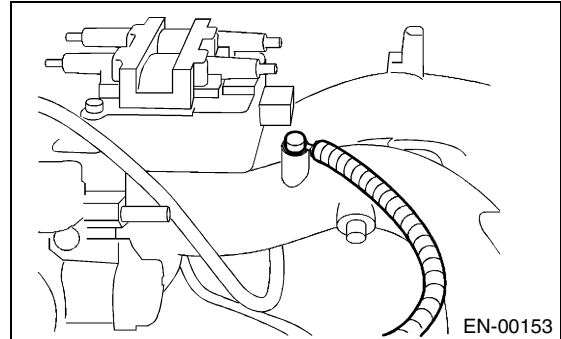

## C: NOTE

### 1. DESCRIPTION

- The on-board diagnostics (OBD) system detects and indicates a fault in various inputs and outputs of the complex electronic control. CHECK ENGINE malfunction indicator lamp (MIL) in the combination meter indicates occurrence of a fault or trouble.
- Further, against such a failure or sensors as may disable the drive, the fail-safe function is provided to ensure the minimal driveability.
- The OBD system incorporated with the vehicles within this engine family complies with Section 1968.1, California Code of Regulations (OBD-II regulation). The OBD system monitors the components and the system malfunction listed in Engine Section which affects on emissions.
- When the system decides that a malfunction occurs, MIL illuminates. At the same time of the MIL illumination or blinking, a diagnostic trouble code (DTC) and a freeze frame engine conditions are stored into on-board computer.
- The OBD system stores freeze frame engine condition data (engine load, engine coolant temperature, fuel trim, engine speed and vehicle speed, etc.) into on-board computer when it detects a malfunction first.
- If the OBD system detects the various malfunctions including the fault of fuel trim or misfire, the OBD system first stores freeze frame engine conditions about the fuel trim or misfire.
- When the malfunction does not occur again for three consecutive driving cycles, MIL is turned off, but DTC remains at on-board computer.
- The OBD-II system is capable of communication with a general scan tool (OBD-II general scan tool) formed by ISO 9141 CARB.

# GENERAL DESCRIPTION

## ENGINE (DIAGNOSTICS)

- The OBD-II diagnostics procedure is different from the usual diagnostics procedure. When troubleshooting OBD-II vehicles, connect Subaru Select Monitor or the OBD-II general scan tool to the vehicle.

### 2. ENGINE AND EMISSION CONTROL SYSTEM

- The Multipoint Fuel Injection (MFI) system is a system that supplies the optimum air-fuel mixture to the engine for all the various operating conditions through the use of the latest electronic technology.

With this system fuel, which is pressurized at a constant pressure, is injected into the intake air passage of the cylinder head. The injection quantity of fuel is controlled by an intermittent injection system where the electro-magnetic injection valve (fuel injector) opens only for a short period of time, depending on the quantity of air required for one cycle of operation. In actual operation, the injection quantity is determined by the duration of an electric pulse applied to the fuel injector and this permits simple, yet highly precise metering of the fuel.

- Further, all the operating conditions of the engine are converted into electric signals, and this results in additional features of the system, such as large

improved adaptability, easier addition of compensating element, etc.



The MFI system also has the following features:

- Reduced emission of harmful exhaust gases.
- Reduced in fuel consumption.
- Increased engine output.
- Superior acceleration and deceleration.
- Superior startability and warm-up performance in cold weather since compensation is made for coolant and intake air temperature.

### 3. AUTOMATIC TRANSMISSION AND ELECTRONIC-HYDRAULIC CONTROL SYSTEM

The electronic-hydraulic control system consists of various sensors and switches, a transmission control module (TCM) and the hydraulic controller including solenoid valves. The system controls the transmission proper including shift control, lock-up control, overrunning clutch control, line pressure control and shift timing control. It also controls the AWD transfer clutch. In other words, the system detects various operating conditions from various input signals and sends output signals to shift solenoids 1, 2 and low clutch timing solenoid and 2-4 brake timing solenoid, line pressure duty solenoid, lock-up duty solenoid, transfer duty solenoid and 2-4 brake duty solenoid (a total of eight solenoids).

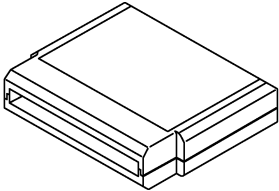
## D: PREPARATION TOOL

ILLUSTRATION	TOOL NUMBER	DESCRIPTION	REMARKS
 <p>ST24082AA210</p>	24082AA210 (New adopted tool)	CARTRIDGE	Troubleshooting for electrical systems.
 <p>ST22771AA030</p>	22771AA030	SUBARU SELECT MONITOR KIT	Troubleshooting for electrical systems. <ul style="list-style-type: none"> <li>• English: 22771AA030 (Without printer)</li> <li>• German: 22771AA070 (Without printer)</li> <li>• French: 22771AA080 (Without printer)</li> <li>• Spanish: 22771AA090 (Without printer)</li> </ul>



## 4. Electrical Components Location

### A: LOCATION

#### 1. ENGINE

##### • MODULE

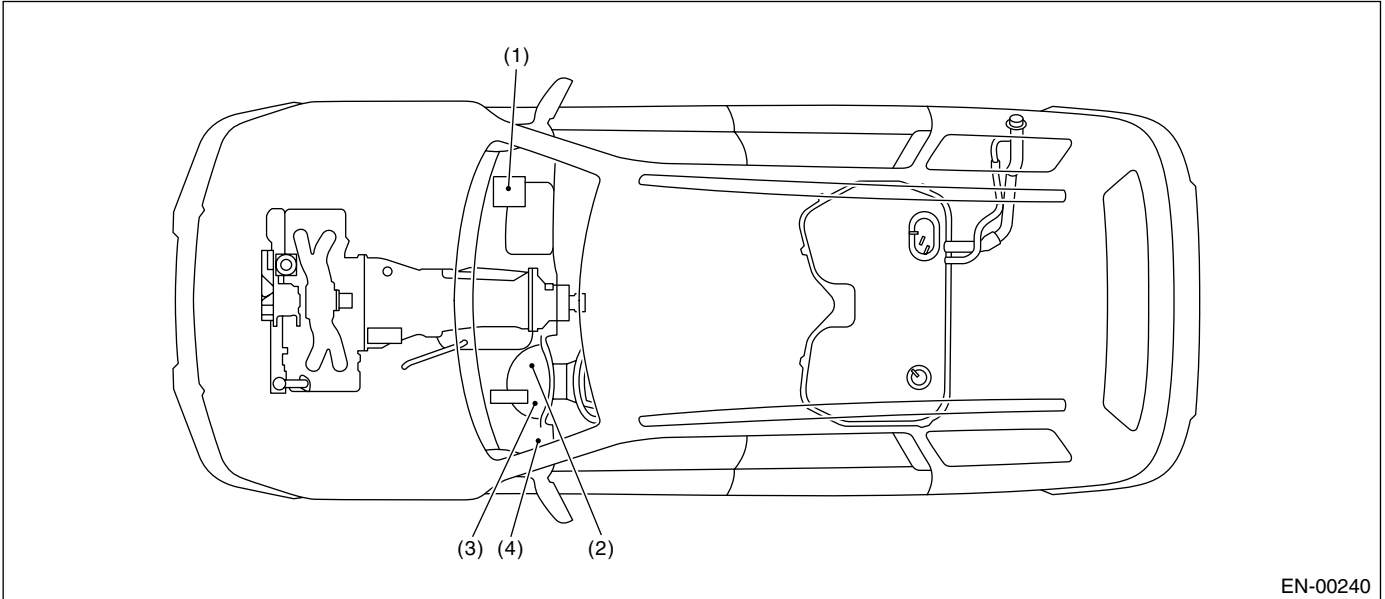

EN-00240

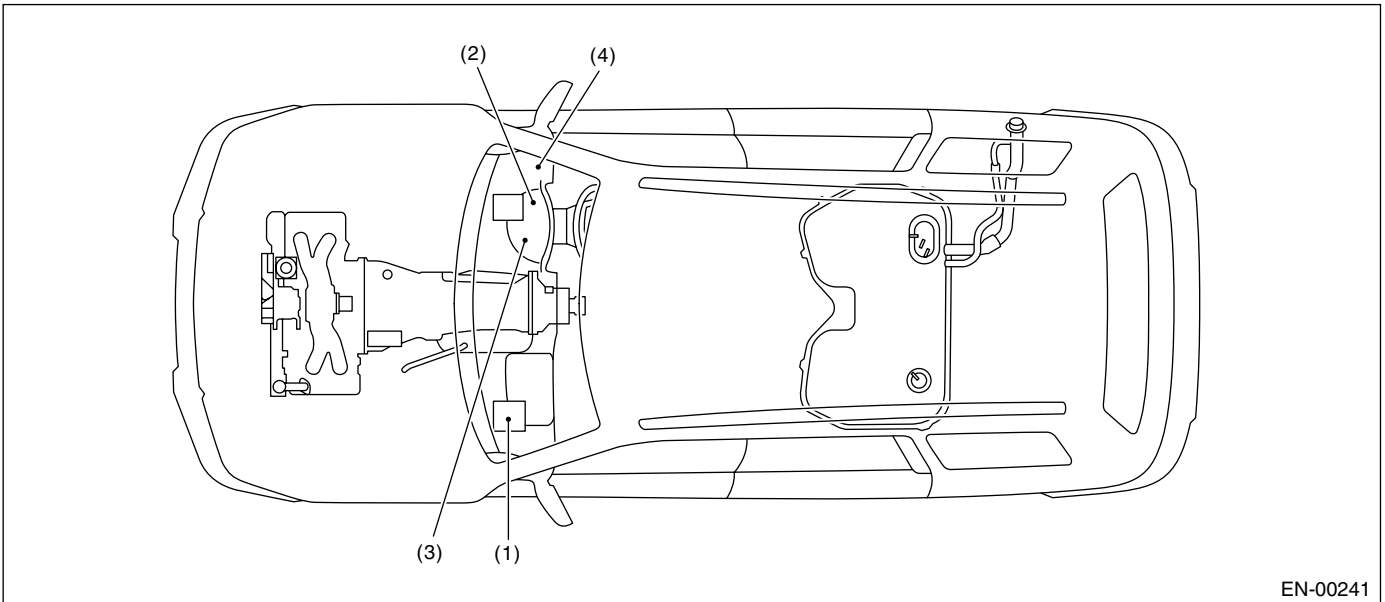

EN-00241

- |   |                         |
|---|-------------------------|
| (1) Engine control module (ECM)                   | (3) Test mode connector |
| (2) CHECK ENGINE malfunction indicator lamp (MIL) | (4) Data link connector |

# ELECTRICAL COMPONENTS LOCATION

## ENGINE (DIAGNOSTICS)

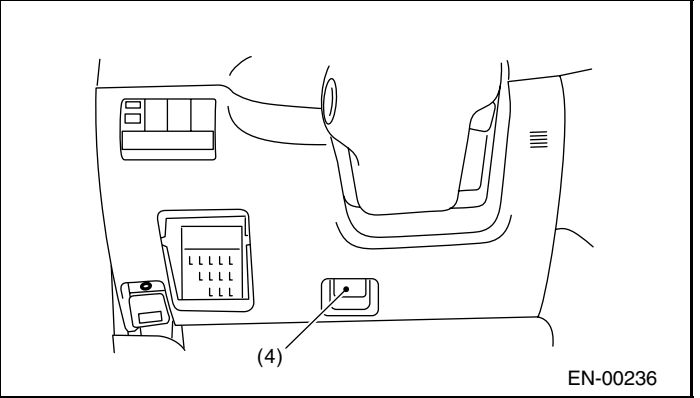
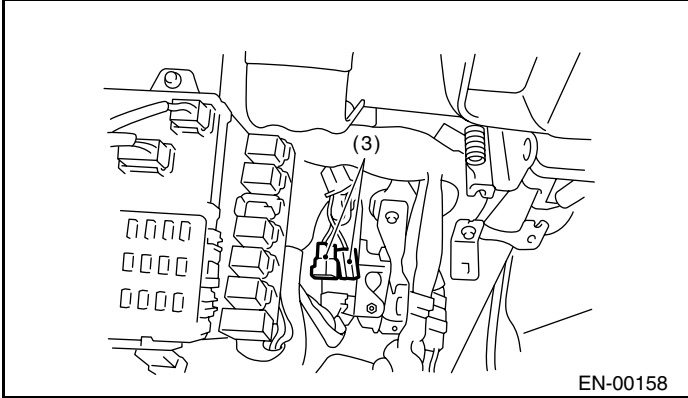
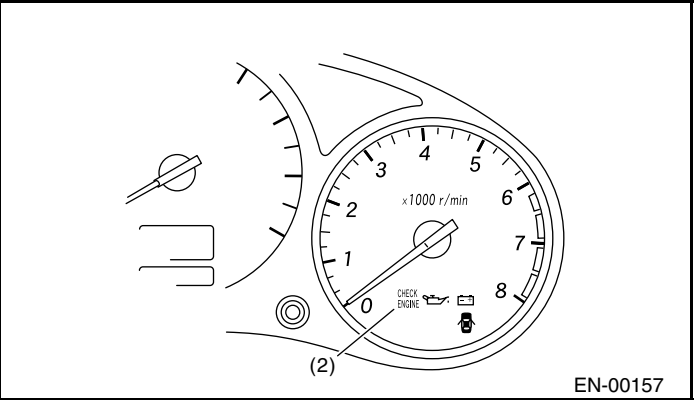
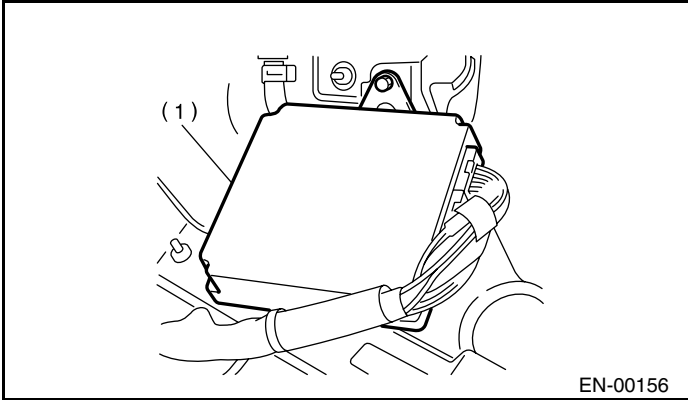

# ELECTRICAL COMPONENTS LOCATION

ENGINE (DIAGNOSTICS)

## • SENSOR

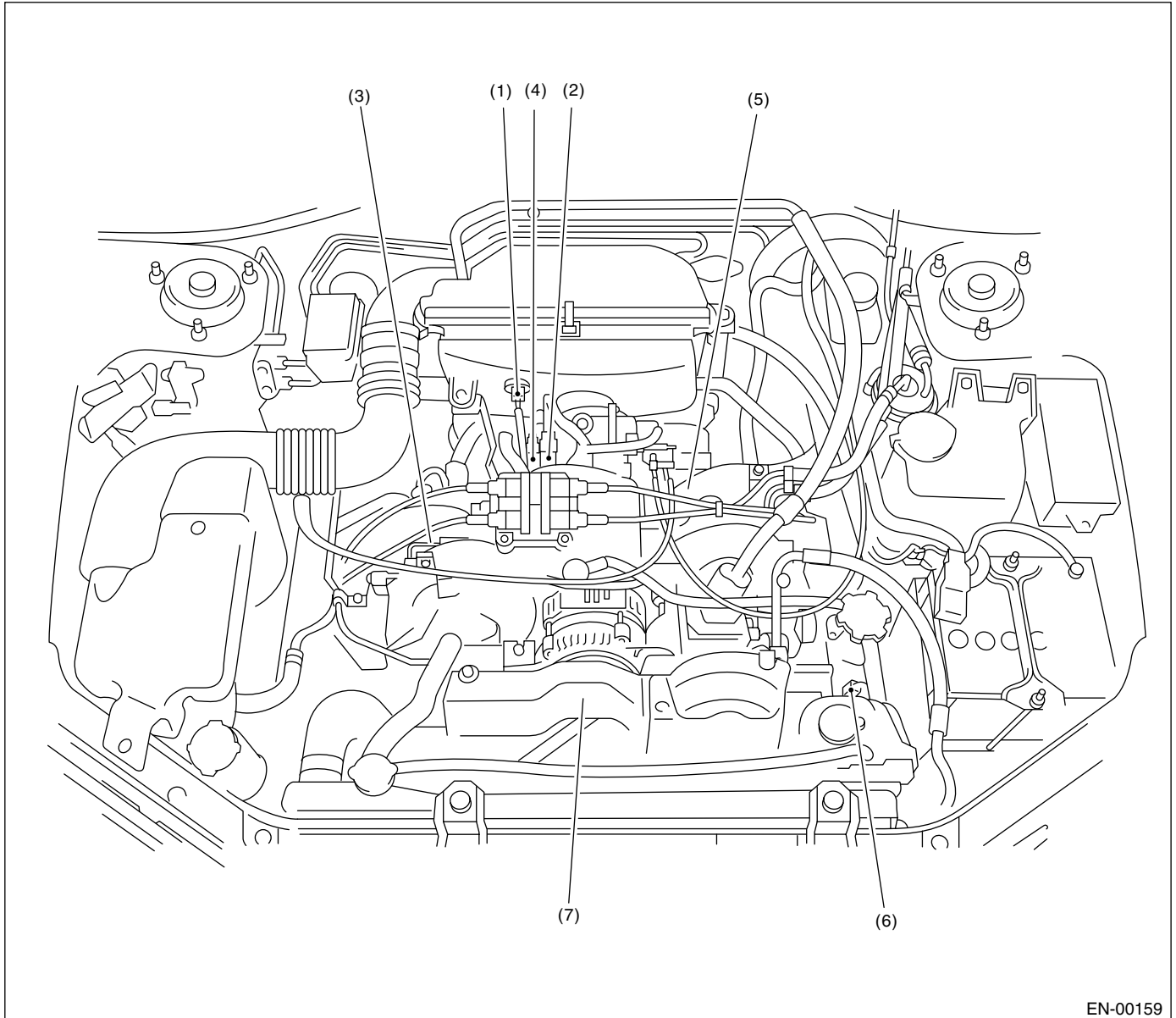

- |                                       |                              |                                |
|---------------------------------------|------------------------------|--------------------------------|
| (1) Intake air temperature sensor     | (4) Throttle position sensor | (7) Crankshaft position sensor |
| (2) Pressure sensor                   | (5) Knock sensor             |                                |
| (3) Engine coolant temperature sensor | (6) Camshaft position sensor |                                |

# ELECTRICAL COMPONENTS LOCATION

## ENGINE (DIAGNOSTICS)



EN-00006



EN-00160

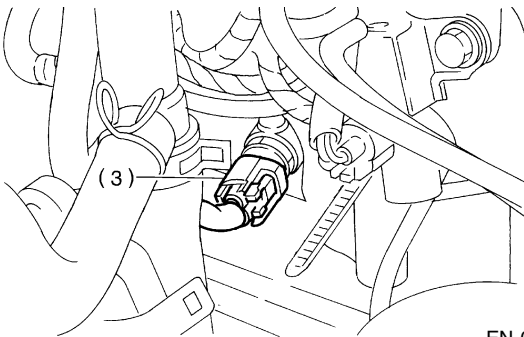

EN-00008

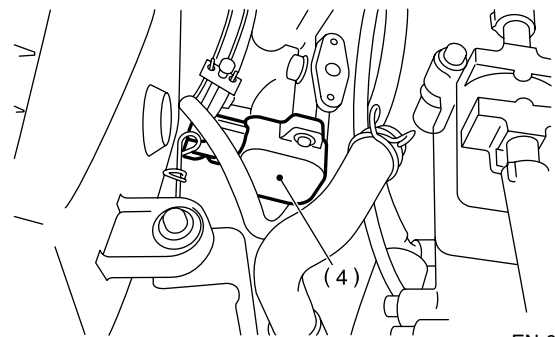

EN-00161

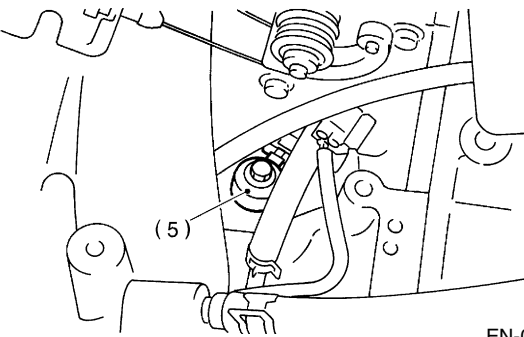

EN-00010

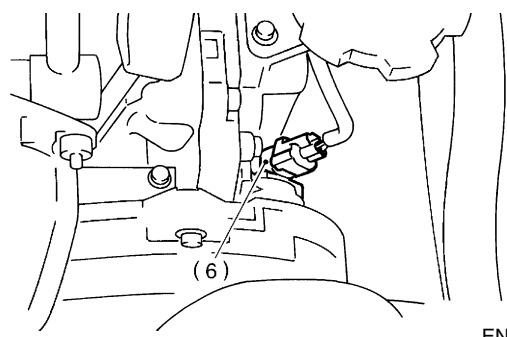

EN-00011

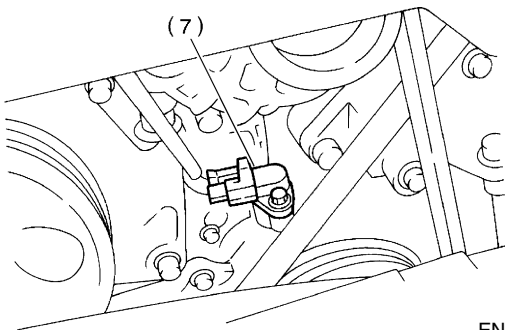

EN-00012

**SUBARU.**

# ELECTRICAL COMPONENTS LOCATION

ENGINE (DIAGNOSTICS)

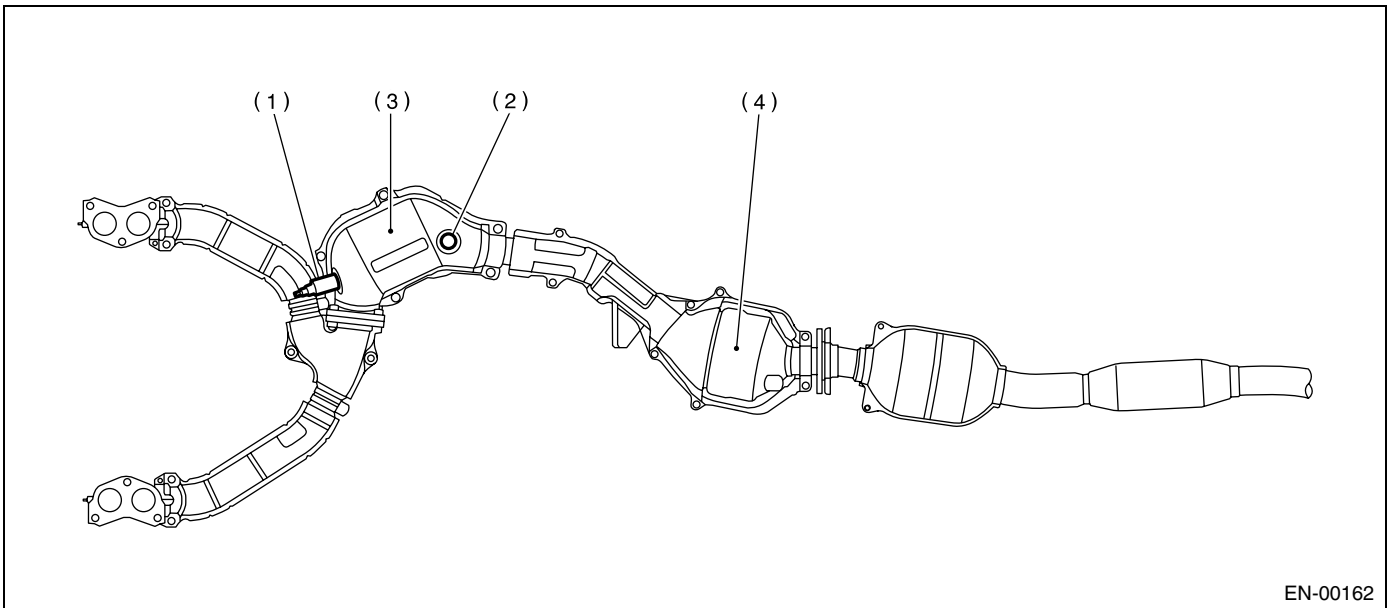

- (1) Front oxygen (A/F) sensor
- (2) Rear oxygen sensor
- (3) Front catalytic converter
- (4) Rear catalytic converter

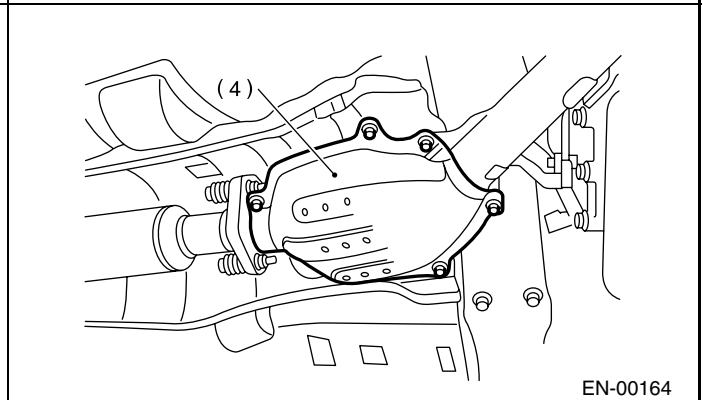
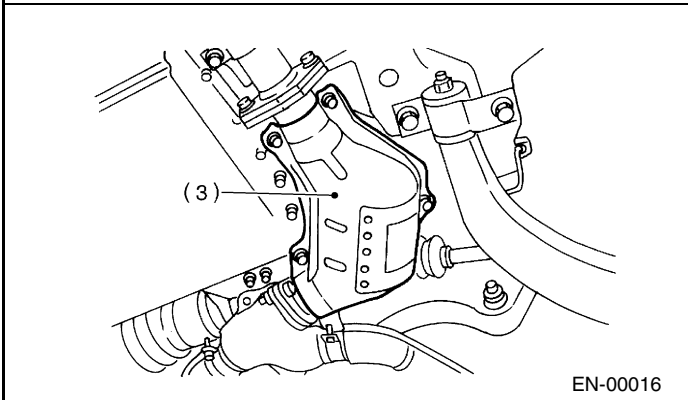
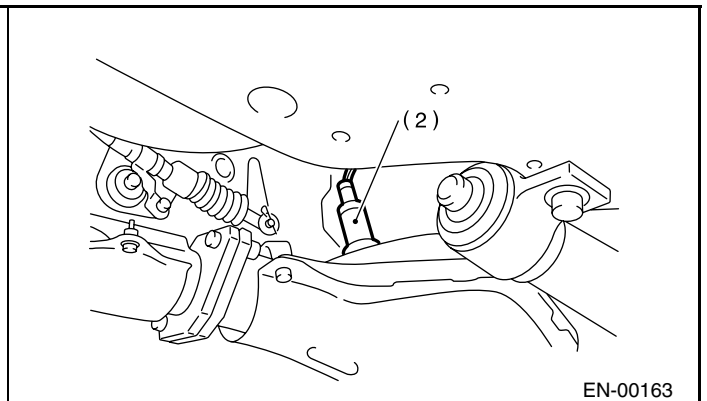
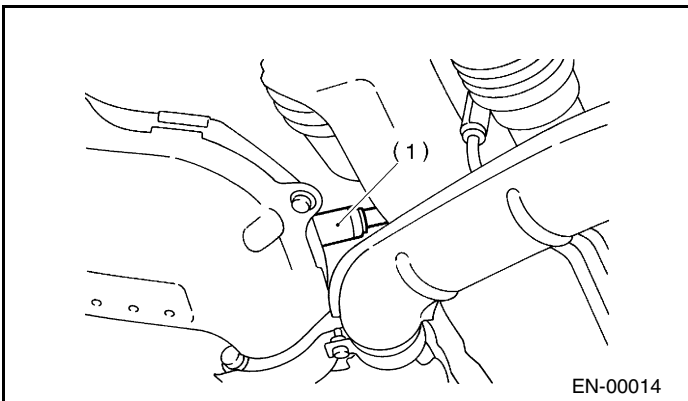

# ELECTRICAL COMPONENTS LOCATION

## ENGINE (DIAGNOSTICS)

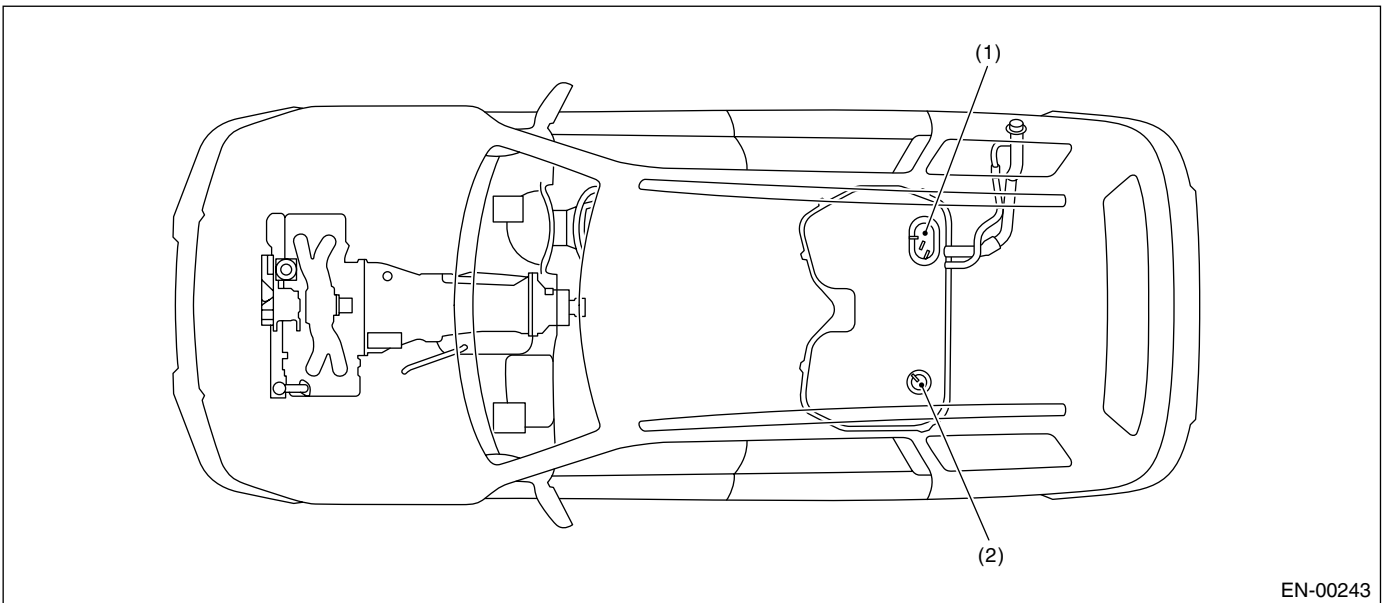
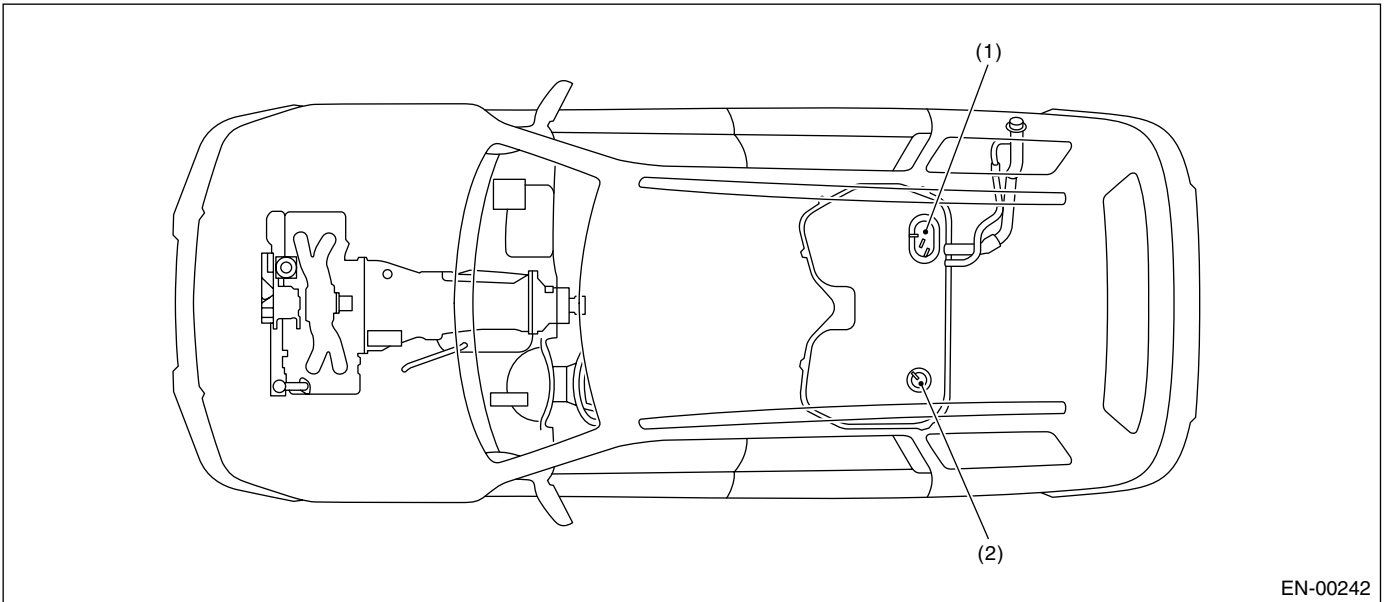

(1) Fuel level sensor

(2) Fuel sub level sensor

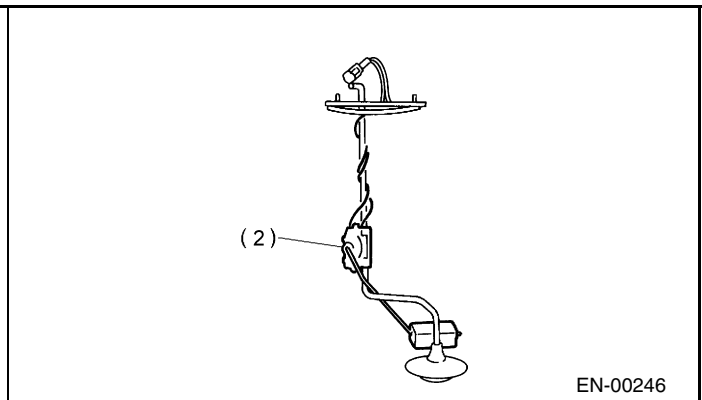
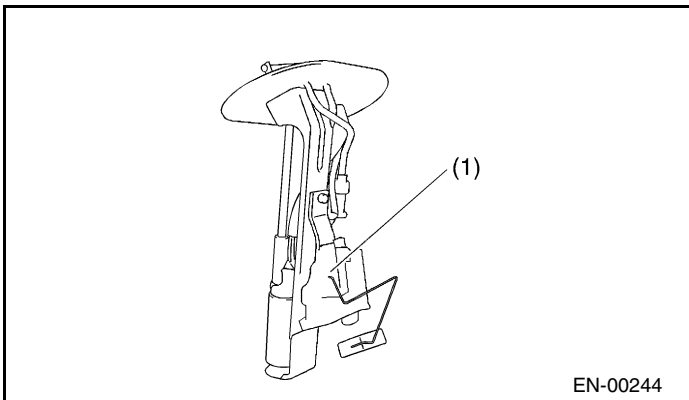

# ELECTRICAL COMPONENTS LOCATION

ENGINE (DIAGNOSTICS)

## • SOLENOID VALVE, EMISSION CONTROL SYSTEM PARTS AND IGNITION SYSTEM PARTS

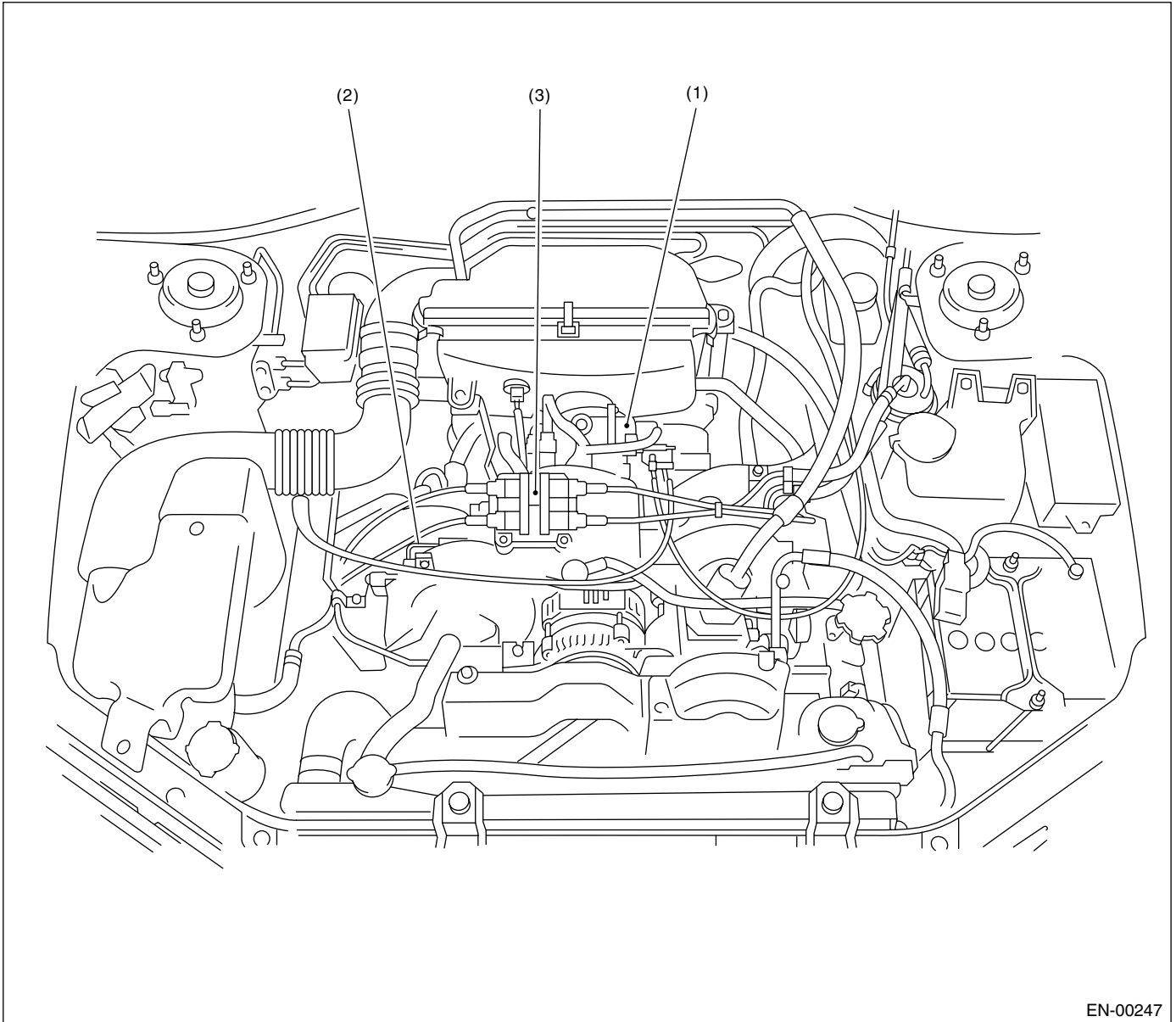

EN-00247

(1) Idle air control solenoid valve

(2) Purge control solenoid valve

(3) Ignition coil / ignitor ASSY

# ELECTRICAL COMPONENTS LOCATION

## ENGINE (DIAGNOSTICS)

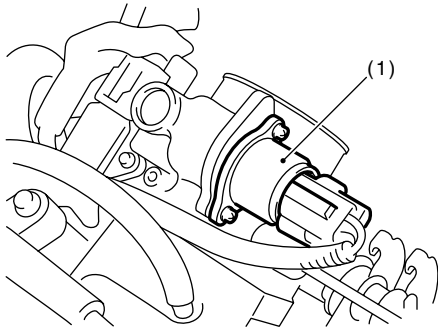

EN-00249

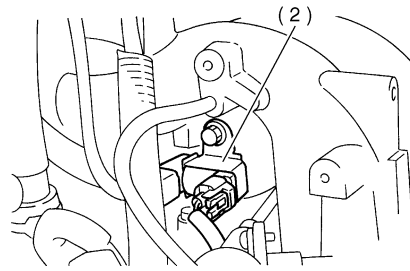

EN-00250

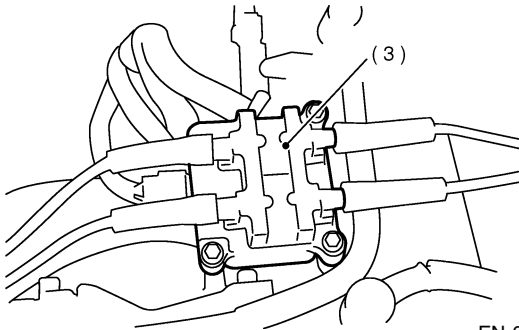

EN-00251

**SUBARU.**



# ELECTRICAL COMPONENTS LOCATION

ENGINE (DIAGNOSTICS)

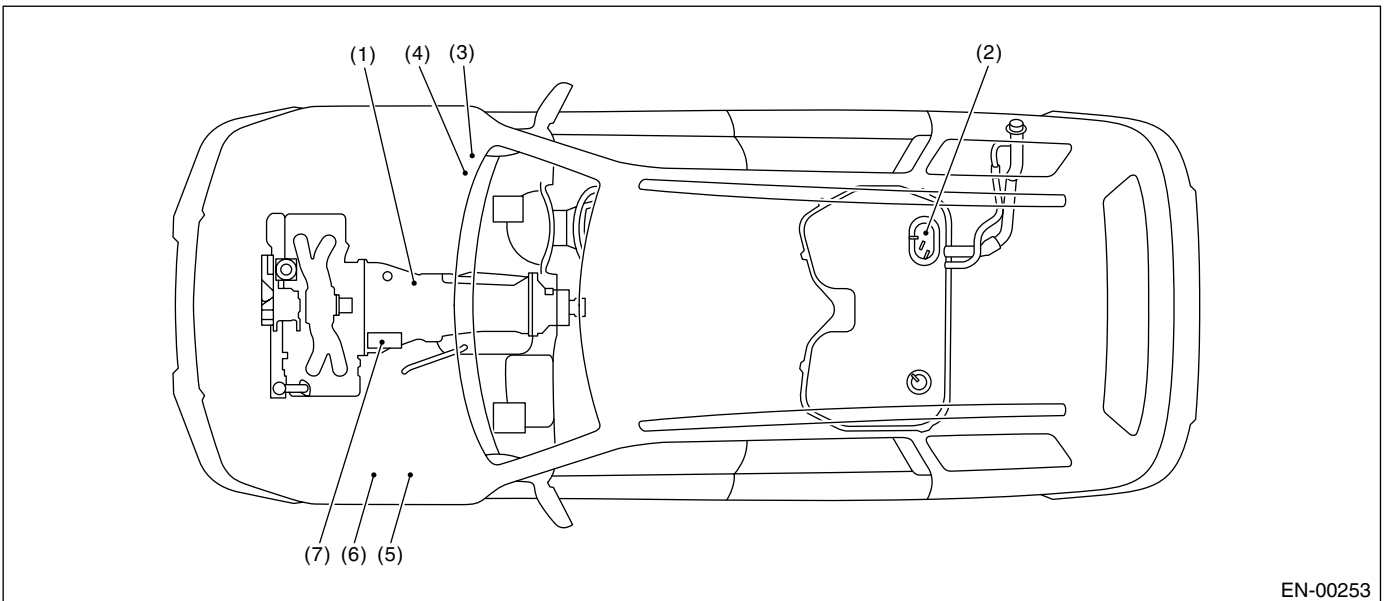
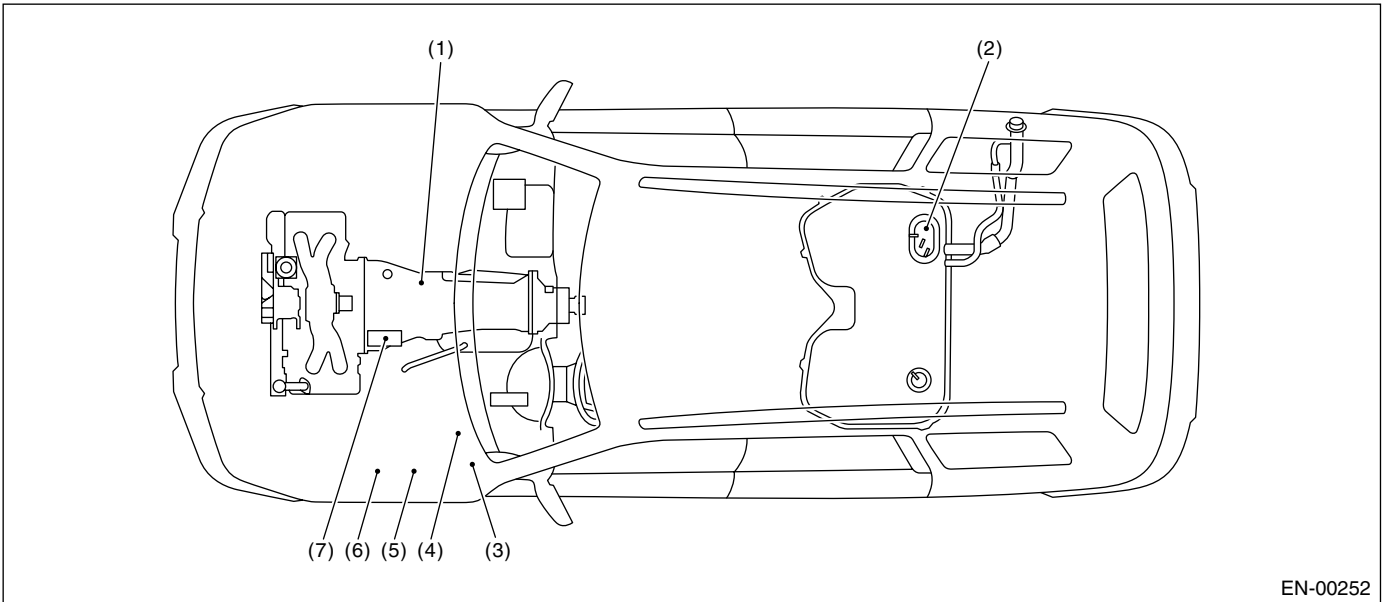

- |                      |                             |             |
|----------------------|-----------------------------|-------------|
| (1) Inhibitor switch | (4) Fuel pump relay         | (7) Starter |
| (2) Fuel pump        | (5) Radiator main fan relay |             |
| (3) Main relay       | (6) Radiator sub fan relay  |             |

# ELECTRICAL COMPONENTS LOCATION

## ENGINE (DIAGNOSTICS)

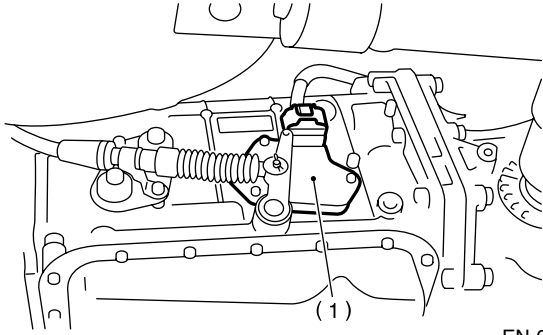

EN-00178

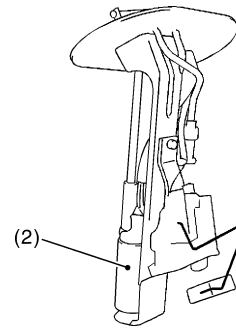

EN-00254

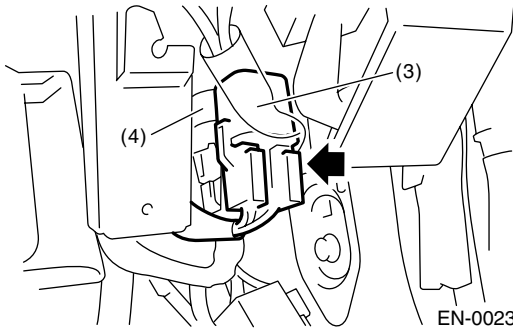

EN-00237

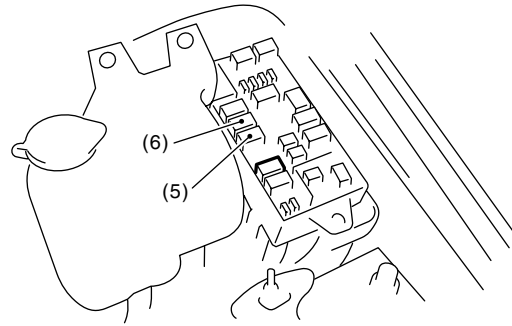

EN-00180

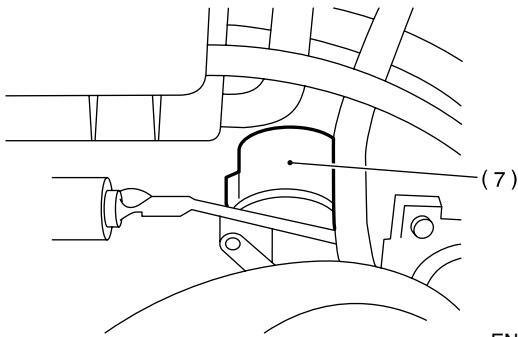

EN-00181

**SUBARU.**

# ELECTRICAL COMPONENTS LOCATION

ENGINE (DIAGNOSTICS)

## 2. TRANSMISSION

### • MODULE

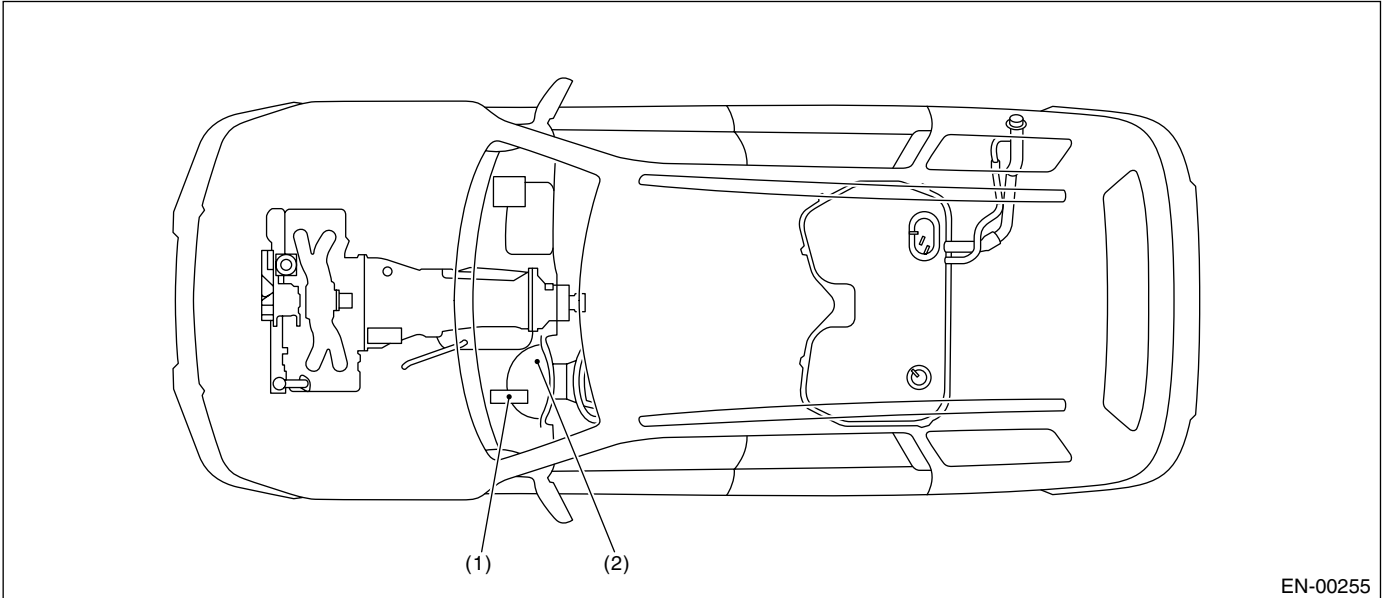

EN-00255

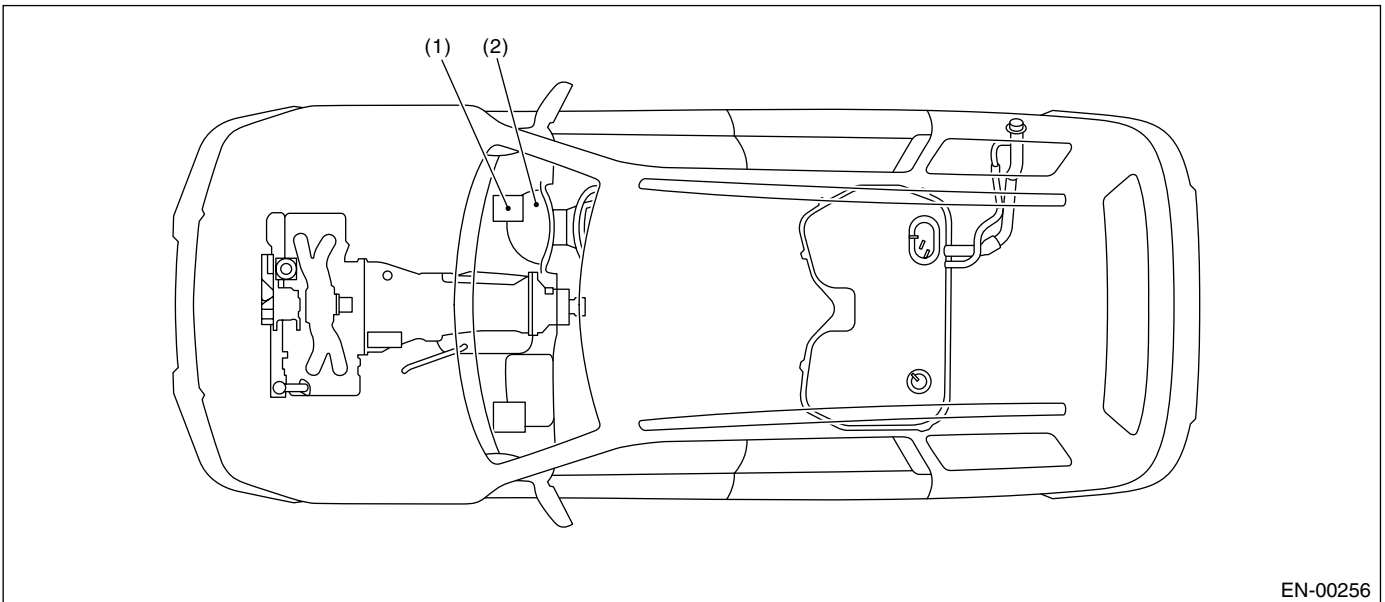

EN-00256

(1) Transmission Control Module (TCM) (for AT vehicles)

(2) AT diagnostic indicator light (for AT vehicles)

# ELECTRICAL COMPONENTS LOCATION

## ENGINE (DIAGNOSTICS)

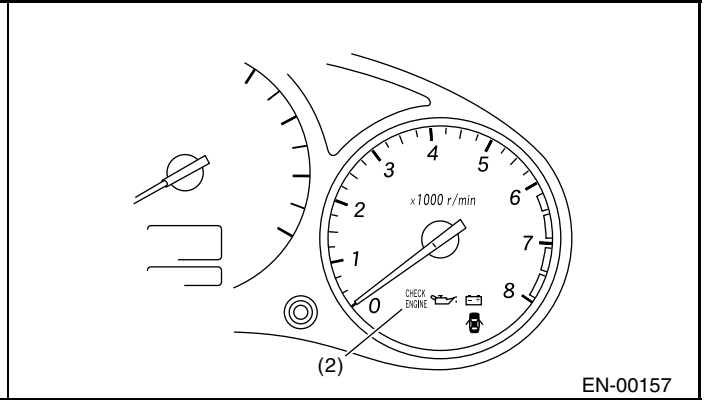
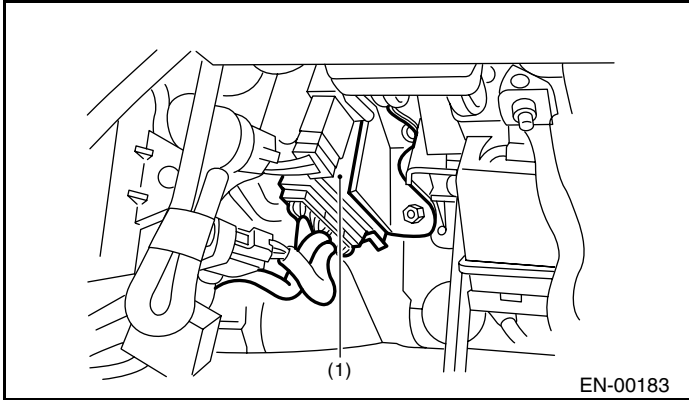

### • SENSOR

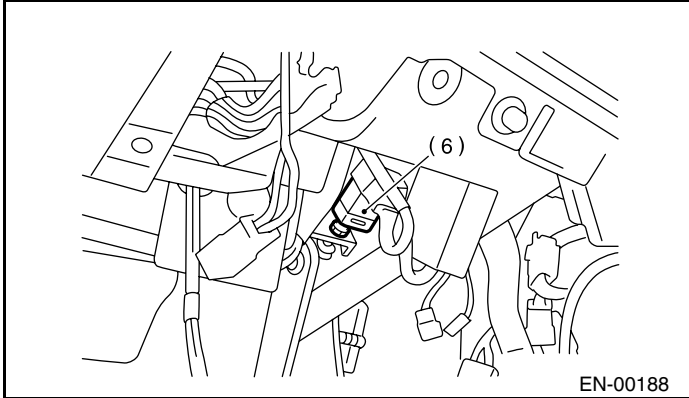
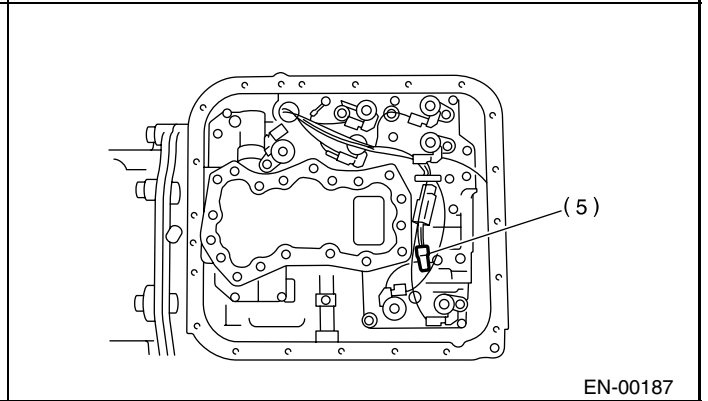
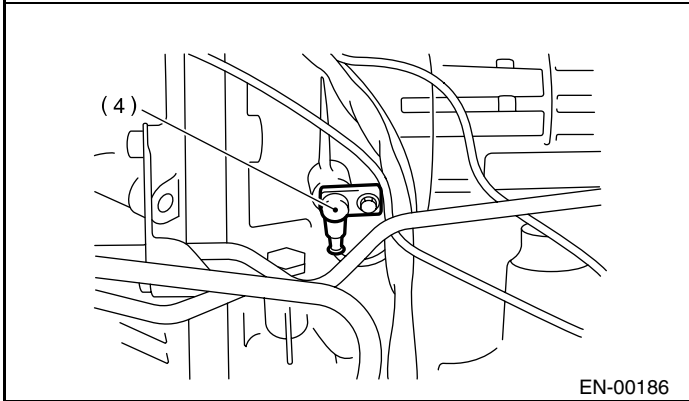
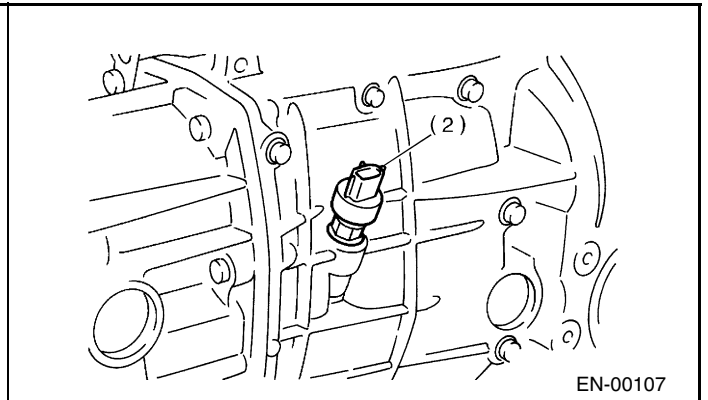
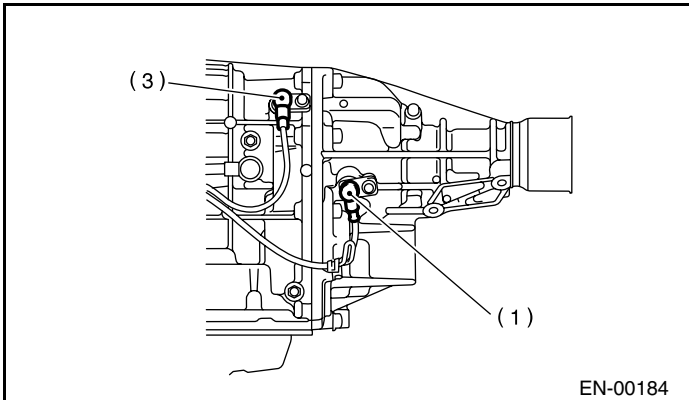

- (1) Rear vehicle speed sensor (for AT vehicles)
- (2) Front vehicle speed sensor (for MT vehicles)
- (3) Front vehicle speed sensor (for AT vehicles)
- (4) Torque converter turbine speed sensor
- (5) ATF temperature sensor (for AT vehicles)

- (6) Brake light switch

# ELECTRICAL COMPONENTS LOCATION

ENGINE (DIAGNOSTICS)

## • SOLENOID VALVE AND SWITCH (AT VEHICLES)

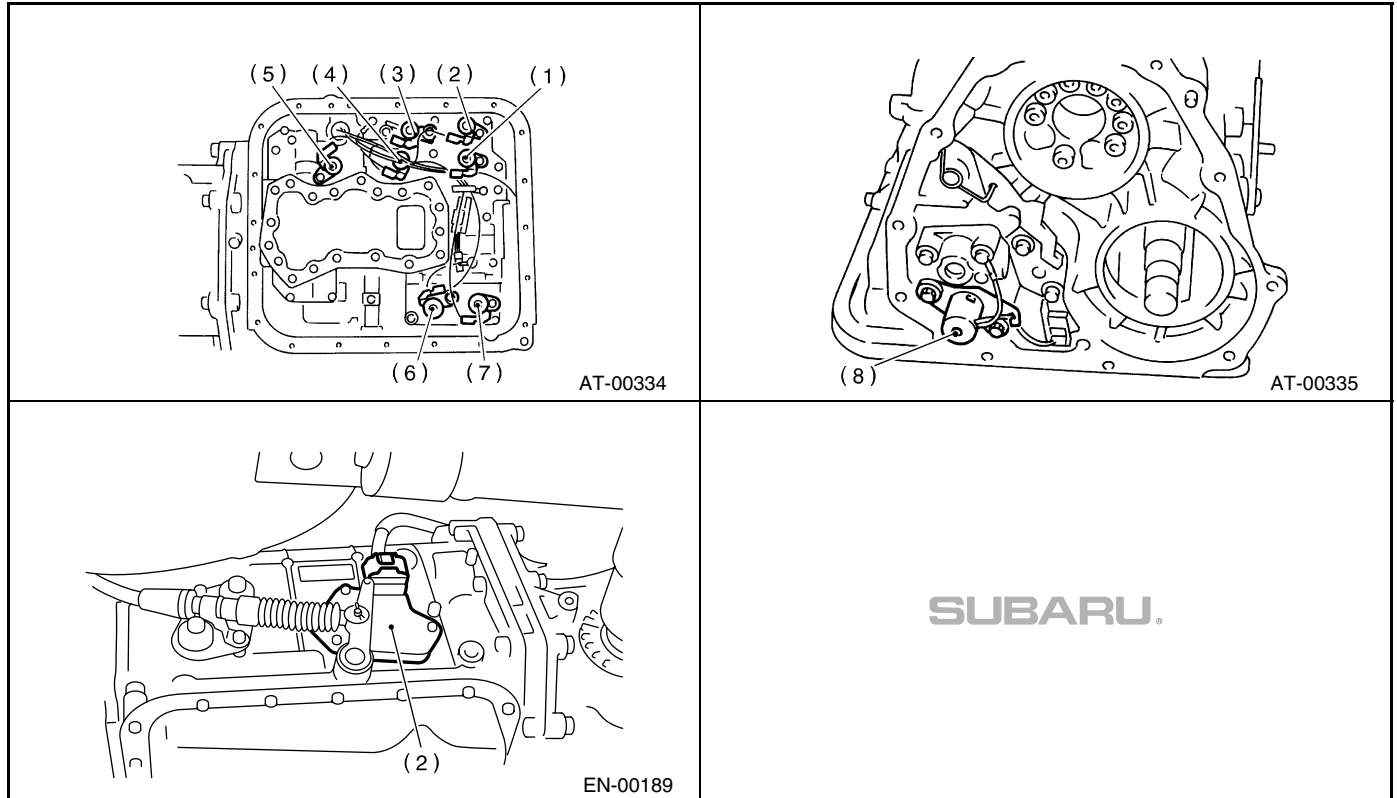

- (1) Shift solenoid valve 1
- (2) Shift solenoid valve 2
- (3) Line pressure duty solenoid
- (4) Low clutch timing solenoid
- (5) Lock up duty solenoid
- (6) 2-4 brake duty solenoid
- (7) 2-4 brake timing solenoid
- (8) Transfer duty solenoid
- (9) Inhibitor switch

## • SOLENOID VALVE AND SWITCH (MT VEHICLES)

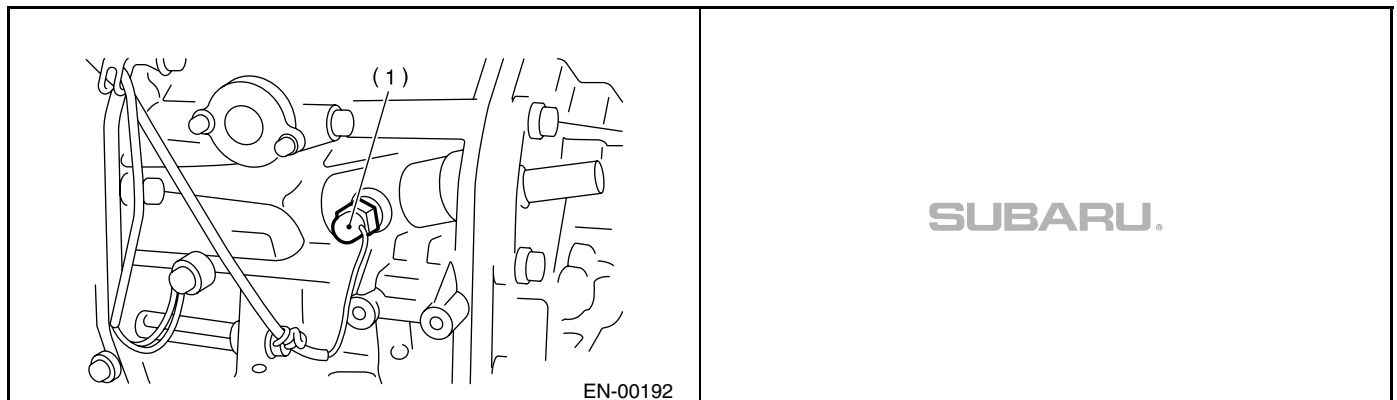

- (1) Neutral position switch

# ENGINE CONTROL MODULE (ECM) I/O SIGNAL

ENGINE (DIAGNOSTICS)

## 5. Engine Control Module (ECM) I/O Signal

### A: ELECTRICAL SPECIFICATION

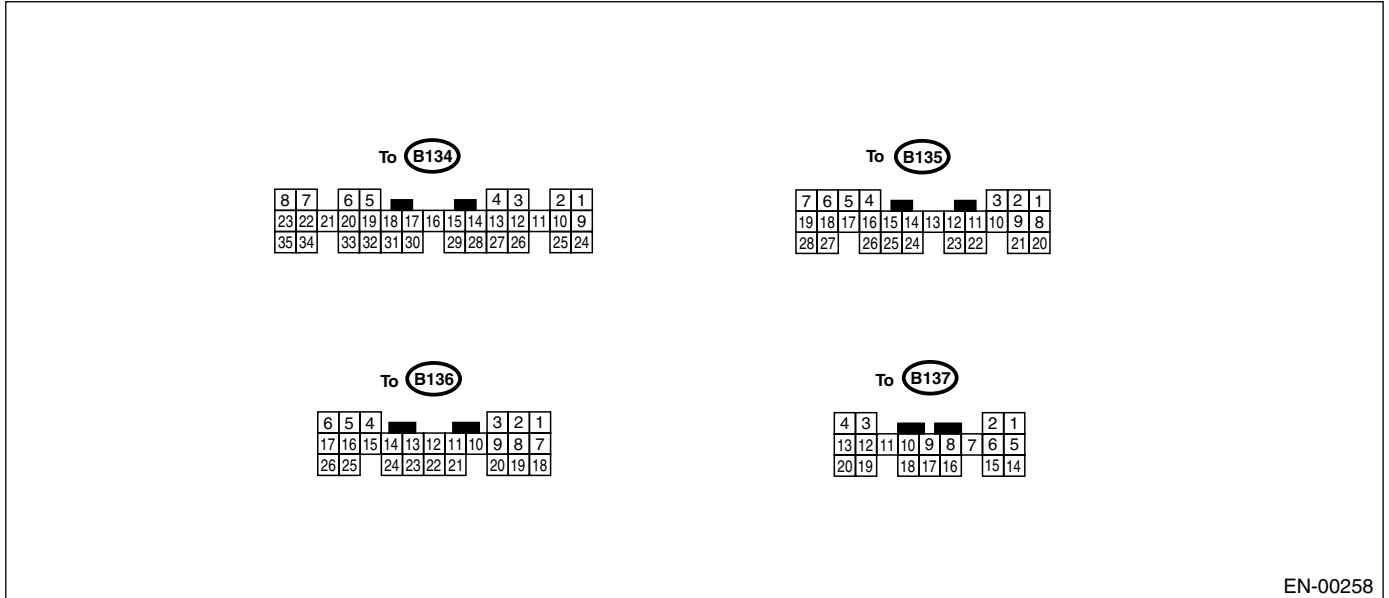

EN-00258

Content		Con- nector No.	Terminal No.	Signal (V)		Note
				Ignition SW ON (Engine OFF)	Engine ON (Idling)	
Crank- shaft position sensor	Signal (+)	B135	6	0	-7 to +7	Sensor output waveform
	Signal (-)	B135	17	0	0	—
	Shield	B135	28	0	0	—
Camshaft position sensor	Signal (+)	B135	7	0	-7 to +7	Sensor output waveform
	Signal (-)	B135	18	0	0	—
	Shield	B135	28	0	0	—
Throttle position sensor	Signal	B135	13	Fully closed: 0.2 — 1.0 Fully opened: 4.2 — 4.7		—
	Power supply	B135	3	5	5	—
	GND (sen- sor)	B135	19	0	0	—
Rear oxy- gen sen- sor	Signal	B135	14	0	0 — 0.9	—
	Shield	B137	15	0	0	—
	GND (sen- sor)	B135	19	0	0	—
Front oxy- gen (A/F) sensor heater	Signal 1	B136	13	0 — 1.0	0 — 1.0	—
	Signal 2	B136	22	0 — 1.0	0 — 1.0	—
Rear oxygen sensor heater signal		B136	4	0 — 1.0	0 — 1.0	—
Engine coolant tempera- ture sen- sor	Signal	B135	12	1.0 — 1.4	1.0 — 1.4	After warm-up the engine.
	GND (sen- sor)	B135	19	0	0	After warm-up the engine.
Vehicle speed signal		B137	10	0 or 5	0 or 5	"5" and "0" are repeatedly dis- played when vehicle is driven.
Starter switch		B136	20	0	0	Cranking: 8 — 14

# ENGINE CONTROL MODULE (ECM) I/O SIGNAL

ENGINE (DIAGNOSTICS)

Content		Con- nector No.	Terminal No.	Signal (V)		Note
				Ignition SW ON (Engine OFF)	Engine ON (Idling)	
A/C switch		B136	11	ON: 10 — 13 OFF: 0	ON: 13 — 14 OFF: 0	—
Ignition switch		B136	10	10 — 13	13 — 14	—
Neutral position switch	MT	B136	21	ON: 12±0.5 OFF: 0		Switch is ON when gear is in neutral position.
	AT	B136	21	ON: 0 OFF: 12±0.5		Switch is ON when shift is in "N" or "P" position.
Test mode connector		B136	3	5	5	When connected: 0
Knock sensor	Signal	B135	16	2.8	2.8	—
	Shield	B135	27	0	0	—
Back-up power supply		B135	9	10 — 13	13 — 14	Ignition switch "OFF": 10 — 13
Control unit power sup- ply		B135	1	10 — 13	13 — 14	—
		B135	2	10 — 13	13 — 14	—
Sensor power supply		B135	3	5	5	—
Ignition control	#1, #2	B134	33	0	1 — 3.4	Waveform
	#3, #4	B134	32	0	1 — 3.4	Waveform
Fuel injec- tor	#1	B134	34	10 — 13	1 — 14	Waveform
	#2	B134	23	10 — 13	1 — 14	Waveform
	#3	B134	22	10 — 13	1 — 14	Waveform
	#4	B134	8	10 — 13	1 — 14	Waveform
Idle air control solenoid valve	Signal 1	B134	20	—	1 — 13	Waveform
	Signal 2	B134	6	—	1 — 13	Waveform
	Signal 3	B134	5	—	1 — 13	Waveform
	Signal 4	B134	19	—	1 — 13	Waveform
	Power supply	B135	2	10 — 13	13 — 14	—
Fuel pump relay control		B134	2	ON: 0.5, or less OFF: 10 — 13	0.5, or less	—
A/C relay control		B134	9	ON: 0.5, or less OFF: 10 — 13	ON: 0.5, or less OFF: 13 — 14	—
Radiator fan relay 1 control		B134	14	ON: 0.5, or less OFF: 10 — 13	ON: 0.5, or less OFF: 13 — 14	—
Radiator fan relay 2 control		B134	13	ON: 0.5, or less OFF: 10 — 13	ON: 0.5, or less OFF: 13 — 14	With A/C vehicles only
Self-shutoff control		B136	12	10 — 13	13 — 14	—
Malfunction indicator lamp		B134	28	—	—	Light "ON": 1, or less Light "OFF": 10 — 14
Engine speed output		B134	10	—	0 — 13, or more	Waveform
Torque control 1 signal		B136	1	5	5	—
Torque control 2 signal		B136	18	5	5	—
Torque control cut sig- nal		B136	15	8	8	—
Purge control solenoid valve		B134	29	ON: 1, or less OFF: 10 — 13	ON: 1, or less OFF: 13 — 14	—
Fuel level sensor		B135	25	0.12 — 4.75	0.12 — 4.75	—
EGR sole- noid valve	Signal 1	B134	18	0 or 10 — 13	0 or 10 — 13	—
	Signal 2	B134	17	0 or 10 — 13	0 or 10 — 13	—
	Signal 3	B134	16	0 or 10 — 13	0 or 10 — 13	—
	Signal 4	B134	15	0 or 10 — 13	0 or 10 — 13	—
AT diagnosis input sig- nal		B137	19	Less than 1 ↔ More than 4	Less than 1 ↔ More than 4	Waveform

# ENGINE CONTROL MODULE (ECM) I/O SIGNAL

## ENGINE (DIAGNOSTICS)

Content	Con- nector No.	Terminal No.	Signal (V)		Note
			Ignition SW ON (Engine OFF)	Engine ON (Idling)	
Small light switch	B137	20	ON: 0 OFF: 10 — 13	ON: 0 OFF: 13 — 14	—
Blower fan switch	B137	13	ON: 0 OFF: 10 — 13	ON: 0 OFF: 13 — 14	—
Rear defogger switch	B137	4	ON: 0 OFF: 10 — 13	ON: 0 OFF: 13 — 14	—
Front oxygen (A/F) sen- sor signal 1	B136	13	—	2.05 — 2.25	—
Front oxygen (A/F) sen- sor signal 2	B136	22	—	1.75 — 1.95	—
Pressure sensor	B135	15	4.0 — 4.8	1.1 — 1.9	—
Intake air temperature sensor	B137	6	3.15 — 3.33	3.15 — 3.33	Intake air temperature: 25°C (75°F)
SSM/GST communica- tion line	B137	16	Less than 1 ←→ More than 4	Less than 1 ←→ More than 4	—
GND (sensors)	B136	19	0	0	—
GND (injectors)	B134	35	0	0	—
GND (ignition system)	B136	26	0	0	—
GND (power supply)	B134	7	0	0	—
GND (control systems)	B137	14	0	0	—
	B135	21	0	0	—
GND (oxygen sensor heater 1)	B136	5	0	0	—
GND (oxygen sensor heater 2)	B136	16	0	0	—



**6. Engine Condition Data****A: ELECTRICAL SPECIFICATION**

Content	Specified data
Engine load	1.6 — 2.9 (%): Idling
	6.4 — 12.8 (%): 2,500 rpm racing

Measuring condition:

- After warm-up the engine.
- Gear position is in “N” or “P” position.
- A/C is turned OFF.
- All accessory switches are turned OFF.

# TRANSMISSION CONTROL MODULE (TCM) I/O SIGNAL

ENGINE (DIAGNOSTICS)

## 7. Transmission Control Module (TCM) I/O Signal

### A: ELECTRICAL SPECIFICATION

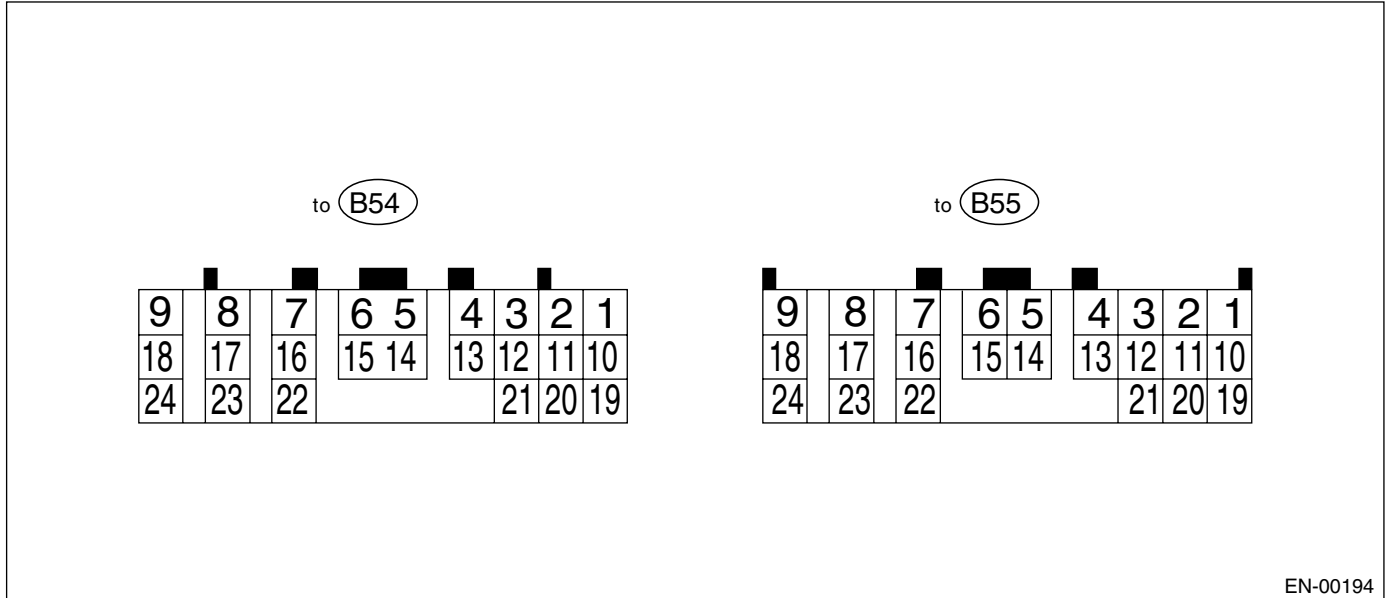

EN-00194

**NOTE:**

Check with ignition switch ON.

Content		Connector No.	Terminal No.	Measuring conditions	Voltage (V)	Resistance to body (ohms)
Back-up power supply		B55	6	Ignition switch OFF	10 — 13	—
Ignition power supply		B54	23	Ignition switch ON (with engine OFF)	10 — 13	—
		B54	24			
Inhibitor switch	“P” range switch	B55	23	Selector lever in “P” range	Less than 1	—
				Selector lever in any other than “P” range	More than 8	
	“N” range switch	B55	22	Selector lever in “N” range	Less than 1	—
				Selector lever in any other than “N” range	More than 8	
	“R” range switch	B55	17	Selector lever in “R” range	Less than 1	—
				Selector lever in any other than “R” range	More than 8	
	“D” range switch	B55	8	Selector lever in “D” range	Less than 1	—
				Selector lever in any other than “D” range	More than 8	
	“3” range switch	B55	18	Selector lever in “3” range	Less than 1	—
				Selector lever in any other than “3” range	More than 8	
	“2” range switch	B54	10	Selector lever in “2” range	Less than 1	—
				Selector lever in any other than “2” range	More than 8	
	“1” range switch	B54	1	Selector lever in “1” range	Less than 1	—
				Selector lever in any other than “1” range	More than 8	
Brake switch		B55	24	Brake pedal depressed.	More than 10.5	—
				Brake pedal released.	Less than 1	

# TRANSMISSION CONTROL MODULE (TCM) I/O SIGNAL

ENGINE (DIAGNOSTICS)

Content	Connector No.	Terminal No.	Measuring conditions	Voltage (V)	Resistance to body (ohms)
ABS signal	B54	19	ABS switch ON	Less than 1	—
			ABS switch OFF	More than 6.5	
AT OIL TEMP light	B54	3	Light ON	Less than 1	—
			Light OFF	More than 9	
Throttle position sensor	B55	2	Throttle fully closed.	Approx. 0.5	—
			Throttle fully open.	Approx. 4.3	
Throttle position sensor power supply	B55	1	Ignition switch ON (With engine OFF)	4.8 — 5.3	—
ATF temperature sensor	B55	11	ATF temperature 20°C (68°F)	1.6 — 2.0	2.1 — 2.9 k
			ATF temperature 80°C (176°F)	0.4 — 0.9	275 — 375
Rear vehicle speed sensor	B55	3	Vehicle stopped.	0	450 — 650
			Vehicle speed at least 20 km/h (12 MPH)	More than 1 (AC range)	
Front vehicle speed sensor	B55	5	Vehicle stopped.	0	450 — 650
			Vehicle speed at least 20 km/h (12 MPH)	More than 1 (AC range)	
Torque converter turbine speed sensor	B55	12	Engine idling after warm-up (D range).	0	450 — 650
			Engine idling after warm-up (N range).	More than 1 (AC range)	
Vehicle speed output signal	B55	13	Vehicle speed at most 10 km/h (6 MPH)	Less than 1 ← → More than 5	—
Engine speed signal	B55	4	Ignition switch ON (with engine OFF)	0	—
			Ignition switch ON (with engine ON)	0 — 13 or more	
Cruise set signal	B54	11	When cruise control is set (SET lamp ON)	Less than 1	—
			When cruise control is not set (SET lamp OFF)	More than 6.5	
Torque control 1 signal	B54	13	Ignition switch ON (with engine ON)	More than 4.8	—
Torque control 2 signal	B54	21	Ignition switch ON (with engine ON)	More than 4.8	—
Torque control cut signal	B54	2	Ignition switch ON	8	—
Intake manifold pressure signal	B55	20	Engine idling after warm-up.	0.4 — 1.8	—
AT load signal	B55	20	Engine idling after warm-up.	1.2 — 1.8	—
Shift solenoid 1	B54	7	1st gear	More than 9	10 — 16
			3rd gear	Less than 1	
Shift solenoid 2	B54	6	2nd gear	More than 9	10 — 16
			4th gear	Less than 1	
Line pressure duty solenoid	B54	9	Throttle fully closed (with engine OFF) after warm-up.	1.5 — 5.0	2.0 — 4.5
			Throttle fully open (with engine OFF) after warm-up.	Less than 1	
Dropping resistor	B54	18	Throttle fully closed (with engine OFF) after warm-up.	More than 8.5	9 — 15
			Throttle fully open (with engine OFF) after warm-up.	Less than 0.5	

# TRANSMISSION CONTROL MODULE (TCM) I/O SIGNAL

## ENGINE (DIAGNOSTICS)

Content	Connector No.	Terminal No.	Measuring conditions	Voltage (V)	Resistance to body (ohms)
Lock-up duty solenoid	B54	16	When lock up occurs.	More than 8.5	10 — 17
			When lock up is released.	Less than 0.5	
Transfer duty solenoid	B54	15	Fuse on FWD switch	More than 8.5	10 — 17
			Fuse removed from FWD switch (with throttle fully open and with select lever in 1st gear).	Less than 0.5	
2-4 brake duty solenoid	B54	8	Throttle fully closed (with engine OFF) after warm-up.	1.5 — 5.0	2.0 — 4.5
			Throttle fully open (with engine OFF) after warm-up.	Less than 1	
2-4 brake dropping resistor	B54	17	Throttle fully closed (with engine OFF) after warm-up.	More than 8.5	9 — 15
			Throttle fully open (with engine OFF) after warm-up.	Less than 0.5	
2-4 brake timing solenoid	B54	5	1st gear	Less than 1	10 — 16
			3rd gear	More than 9	
Low clutch timing solenoid	B54	14	2nd gear	Less than 1	10 — 16
			4th gear	More than 9	
Sensor ground line	B55	21	—	0	Less than 1
System ground line	B55	9	—	0	Less than 1
		19			
FWD switch	B55	14	Fuse removed.	More than 9	—
			Fuse installed.	Less than 1	
FWD indicator light	B54	12	Fuse on FWD switch	Less than 1	—
			Fuse removed from FWD switch	More than 9	
Data link signal (Subaru Select Monitor)	B55	7	—	—	—
		16	—	—	
AT diagnosis signal	B54	4	Ignition switch ON	Less than 1 ← → More than 4	—

## 8. Data Link Connector

### A: NOTE

- 1) This connector is used both for OBD-II general scan tools and the Subaru Select Monitor.
- 2) Terminal No. 4 to No. 6 of the data link connector is used for the Subaru Select Monitor signal.

### CAUTION:

**Do not connect any scan tools other than the OBD-II general scan tools and the Subaru Select Monitor, because the circuit for the Subaru Select Monitor may be damaged.**

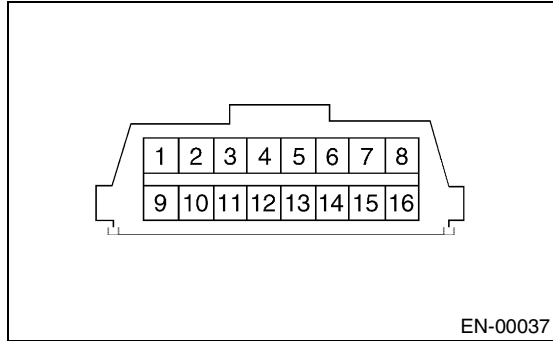

Terminal No.	Contents	Terminal No.	Contents
1	Power supply	9	Blank
2	Blank	10	K line of ISO 9141 CARB
3	Blank	11	Blank
4	Blank	12	Ground
5	Blank	13	Ground
6	Line end check signal	14	Blank
7	Blank	15	Blank
8	Blank	16	Blank

# OBD-II GENERAL SCAN TOOL

ENGINE (DIAGNOSTICS)

## 9. OBD-II General Scan Tool

### A: OPERATION

#### 1. HOW TO USE OBD-II GENERAL SCAN TOOL

- 1) Prepare a general scan tool (OBD-II general scan tool) required by SAE J1978.
- 2) Connect the OBD-II general scan tool to the data link connector located in the lower portion of the instrument panel (on the driver's side).

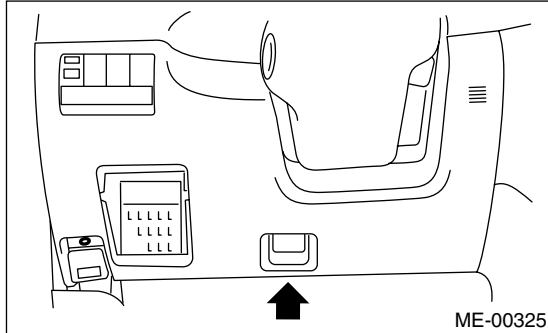

#### 2. MODE \$01 (CURRENT POWERTRAIN DIAGNOSTIC DATA)

Refers to data denoting the current operating condition of analog input/output, digital input/output and/or the powertrain system.

A list of the support data and PID (Parameter Identification) codes are shown in the following table.

PID	Data	Unit of measure
01	Number of emission-related powertrain trouble codes and MIL status	ON/OFF
03	Fuel system control status	—
04	Calculated engine load value	%
05	Engine coolant temperature	°C
06	Short term fuel trim	%
07	Long term fuel trim	%
0B	Intake manifold absolute pressure	kPa
0C	Engine revolution	rpm
0D	Vehicle speed	km/h
0E	Ignition timing advance	°
10	Air flow rate from pressure sensor	g/sec
11	Throttle valve opening angle	%
13	Check whether oxygen sensor is installed.	—
14	Oxygen sensor output voltage and short term fuel trim associated with oxygen sensor—bank 1	V and %
15	Oxygen sensor output voltage and short term fuel trim associated with oxygen sensor—bank 2	V and %
1C	On-board diagnosis system	—

#### NOTE:

Refer to OBD-II general scan tool manufacturer's instruction manual to access generic OBD-II PIDs (MODE \$01).

- 3) Using the OBD-II general scan tool, call up diagnostic trouble code(s) and freeze frame data.

OBD-II general scan tool functions consist of:

- (1) MODE \$01: Current powertrain diagnostic data
- (2) MODE \$02: Powertrain freeze frame data
- (3) MODE \$03: Emission-related powertrain diagnostic trouble codes
- (4) MODE \$04: Clear/Reset emission-related diagnostic information

Read out data according to repair procedures. (For detailed operation procedures, refer to the OBD-II General Scan Tool Operation Manual.)

#### NOTE:

For details concerning diagnostic trouble codes, refer to the List of Diagnostic Trouble Code (DTC). <Ref. to EN(SOHC)-75, List of Diagnostic Trouble Code (DTC).>

### 3. MODE \$02 (POWERTRAIN FREEZE FRAME DATA)

Refers to data denoting the operating condition when trouble is sensed by the on-board diagnosis system. A list of the support data and PID (Parameter Identification) codes are shown in the following table.

PID	Data	Unit of measure
02	Trouble code that caused CARB required freeze frame data storage	—
03	Fuel system control status	—
04	Calculated engine load value	%
05	Engine coolant temperature	°C
06	Short term fuel trim	%
07	Long term fuel trim	%
0B	Intake manifold absolute pressure	kPa
0C	Engine revolution	rpm
0D	Vehicle speed	km/h

**NOTE:**

Refer to OBD-II general scan tool manufacturer's instruction manual to access freeze frame data (MODE \$02).

### 4. MODE \$03 (EMISSION-RELATED POWERTRAIN DIAGNOSTIC TROUBLE CODE)

Refer to Read Diagnostic Trouble Code for information about data denoting emission-related powertrain diagnostic trouble codes. <Ref. to EN(SOHC)-39, Read Diagnostic Trouble Code.>

### 5. MODE \$04 (CLEAR/RESET EMISSION-RELATED DIAGNOSTIC INFORMATION)

Refers to the mode used to clear or reset emission-related diagnostic information (OBD-II trouble diagnostic information).

**NOTE:**

Refer to OBD-II general scan tool manufacturer's instruction manual to clear or reset emission-related diagnostic information (MODE \$04).

# SUBARU SELECT MONITOR

ENGINE (DIAGNOSTICS)

## 10. Subaru Select Monitor

### A: OPERATION

#### 1. HOW TO USE SUBARU SELECT MONITOR

1) Prepare the Subaru Select Monitor kit. <Ref. to EN(SOHC)-8, PREPARATION TOOL, General Description.>

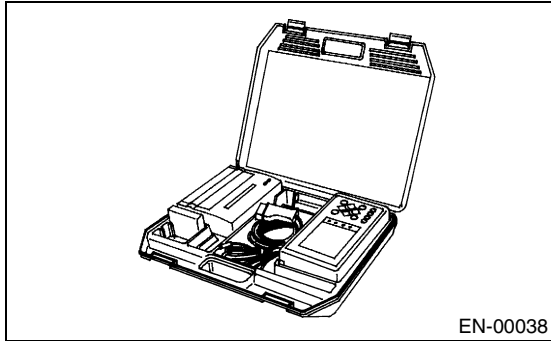

2) Connect the diagnosis cable to Subaru Select Monitor.

3) Insert the cartridge into Subaru Select Monitor. <Ref. to EN(SOHC)-8, PREPARATION TOOL, General Description.>

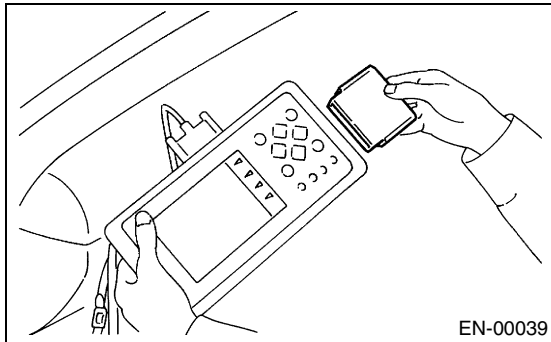

4) Connect the Subaru Select Monitor to data link connector.

(1) Data link connector located in the lower portion of the instrument panel (on the driver's side).

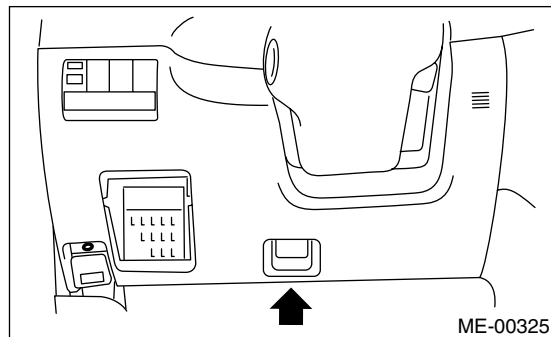

(2) Connect the diagnosis cable to data link connector.

#### CAUTION:

**Do not connect scan tools except for Subaru Select Monitor and OBD-II general scan tool.**

5) Turn the ignition switch to ON (engine OFF) and Subaru Select Monitor switch to ON.

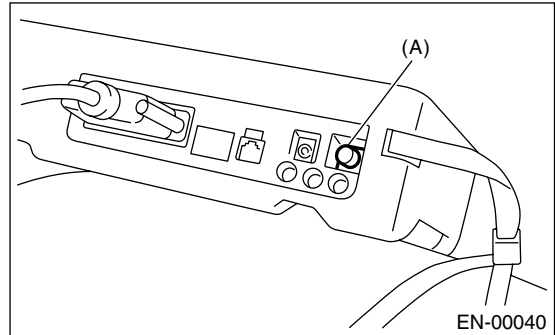

(A) Power switch

6) Using the Subaru Select Monitor, call up diagnostic trouble code(s) and various data, then record them.

#### 2. READ DIAGNOSTIC TROUBLE CODE (DTC) FOR ENGINE. (NORMAL MODE)

Refer to Read Diagnostic Trouble Code for information about how to indicate DTC. <Ref. to EN(SOHC)-39, Read Diagnostic Trouble Code.>

#### 3. READ DIAGNOSTIC TROUBLE CODE (DTC) FOR ENGINE. (OBD MODE)

Refer to Read Diagnostic Trouble Code for information about how to indicate DTC. <Ref. to EN(SOHC)-39, Read Diagnostic Trouble Code.>



## 4. READ CURRENT DATA FOR ENGINE. (NORMAL MODE)

- 1) On the «Main Menu» display screen, select the {Each System Check} and press the [YES] key.
- 2) On the «System Selection Menu» display screen, select the {Engine Control System} and press the [YES] key.
- 3) Press the [YES] key after displayed the information of engine type.
- 4) On the «Engine Diagnosis» display screen, select the {Current Data Display & Save} and press the [YES] key.
- 5) On the «Data Display Menu» display screen, select the {Data Display} and press the [YES] key.
- 6) Using the scroll key, move the display screen up or down until the desired data is shown.
  - A list of the support data is shown in the following table.

Contents	Display	Unit of measure
Battery voltage	Battery Voltage	V
Vehicle speed signal	Vehicle Speed	km/h or MPH
Engine speed signal	Engine Speed	rpm
Engine coolant temperature signal	Coolant Temp.	°C or °F
Ignition timing signal	Ignition Timing	deg
Throttle position signal	Throttle Opening Angle	%
Throttle position signal	Throttle Sensor Voltage	V
Injection pulse width	Fuel Injection #1 Pulse	ms
Idle air control signal	ISC Valve Step	STEP
Engine load data	Engine Load	%
Front oxygen (A/F) sensor resistance	A/F Sensor #1 Resistance	Ohm
Front oxygen (A/F) sensor output signal	A/F Sensor #1	—
Rear oxygen sensor output signal	Rear O <sub>2</sub> Sensor	V
Short term fuel trim	A/F Correction #1	%
Knock sensor signal	Knocking Correction	deg
Atmospheric absolute pressure signal	Atmosphere Pressure	mmHg or kPa or inHg or psi
Intake manifold relative pressure signal	Mani. Relative Pressure	mmHg or kPa or inHg or psi
Intake manifold absolute pressure signal	Mani. Absolute Pressure	mmHg or kPa or inHg or psi
A/F correction (short term fuel trim) by rear oxygen sensor	A/F Correction #3	%
Long term whole fuel trim	A/F Learning #1	%
Front oxygen (A/F) sensor heater current	Front O <sub>2</sub> Heater #1	A
Rear oxygen sensor heater current	Rear O <sub>2</sub> Heater Current	A
Canister purge control solenoid valve duty ratio	CPC Valve Duty Ratio	%
Fuel level signal	Fuel Level	V
Intake air temperature signal	Intake Air Temp.	°C or °F
Learned ignition timing	Learned Ignition Timing	deg
EGR signal	EGR step	STEP
Ignition switch signal	Ignition Switch	ON or OFF
Test mode connector signal	Test Mode Signal	ON or OFF
Neutral position switch signal	Neutral Position Switch	ON or OFF
Air conditioning switch signal	A/C Switch	ON or OFF
Air conditioning signal	A/C Compressor Signal	ON or OFF
Radiator main fan relay signal	Radiator Fan Relay #1	ON or OFF
Fuel pump relay signal	Fuel Pump Relay	ON or OFF
Knocking signal	Knocking Signal	ON or OFF
Radiator sub fan relay signal	Radiator Fan Relay #2	ON or OFF
Power steering switch signal	P/S Switch	ON or OFF
Engine torque control signal #1	Torque Control Signal #1	ON or OFF

# SUBARU SELECT MONITOR

## ENGINE (DIAGNOSTICS)

Contents	Display	Unit of measure
Engine torque control signal #2	Torque Control Signal #2	ON or OFF
Engine torque control permission signal	Torque Permission Signal	ON or OFF
Rear oxygen sensor rich signal	Rear O <sub>2</sub> Rich Signal	ON or OFF
Starter switch signal	Starter Switch Signal	ON or OFF
Idle switch signal	Idle Switch Signal	ON or OFF
Crankshaft position sensor signal	Crankshaft Position Sig.	ON or OFF
Camshaft position sensor signal	Camshaft Position Sig.	ON or OFF
Rear defogger switch signal	Rear Defogger Switch	ON or OFF
Blower fan switch signal	Blower Fan Switch	ON or OFF
Small light switch signal	Light Switch	ON or OFF
AT vehicle ID signal	AT Vehicle ID Signal	ON or OFF
A/C middle pressure switch signal	A/C Mid Pressure Switch	ON or OFF

**NOTE:**

For detailed operation procedure, refer to the SUBARU SELECT MONITOR OPERATION MANUAL.

## 5. READ CURRENT DATA FOR ENGINE. (OBD MODE)

- 1) On the «Main Menu» display screen, select the {Each System Check} and press the [YES] key.
  - 2) On the «System Selection Menu» display screen, select the {Engine Control System} and press the [YES] key.
  - 3) Press the [YES] key after displayed the information of engine type.
  - 4) On the «Engine Diagnosis» display screen, select the {OBD System} and press the [YES] key.
  - 5) On the «OBD Menu» display screen, select the {Current Data Display & Save} and press the [YES] key.
  - 6) On the «Data Display Menu» display screen, select the {Data Display} and press the [YES] key.
  - 7) Using the scroll key, move the display screen up or down until the desired data is shown.
- A list of the support data is shown in the following table.

Contents	Display	Unit of measure
Number of diagnosis code	Number of Diagnosis Code	—
Malfunction indicator lamp status	MI (MIL)	ON or OFF
Monitoring test of misfire	Misfire monitoring	Complete or incomplete
Monitoring test of fuel system	Fuel system monitoring	Complete or incomplete
Monitoring test of comprehensive component	Component monitoring	Complete or incomplete
Test of catalyst	Catalyst Diagnosis	Complete or incomplete
Test of heated catalyst	Heated catalyst	No support
Test of evaporative emission purge control system	Evaporative purge system	Complete or incomplete
Test of secondary air system	Secondary air system	No support
Test of air conditioning system refrigerant	A/C system refrigerant	No support
Test of oxygen sensor	Oxygen sensor	Complete or incomplete
Test of oxygen sensor heater	O <sub>2</sub> Heater Diagnosis	Complete or incomplete
Test of EGR system	EGR system	—
Air fuel ratio control system for bank 1	Fuel System for Bank 1	—
Engine load data	Calculated load value	%
Engine coolant temperature signal	Coolant Temp.	°C or °F
Short term fuel trim by front oxygen (A/F) sensor	Short term fuel trim B1	%
Long term fuel trim by front oxygen (A/F) sensor	Long term fuel trim B1	%
Intake manifold absolute pressure signal	Mani. Absolute Pressure	mmHg or kPa or inHg or psi
Engine speed signal	Engine Speed	rpm
Vehicle speed signal	Vehicle Speed	km/h or MPH
Ignition timing advance for #1 cylinder	Ignition timing adv. #1	°
Intake air temperature signal	Intake Air Temp.	°C or °F
Intake air amount	Mass Air Flow	g/s
Throttle position signal	Throttle Opening Angle	%
Rear oxygen sensor output signal	Oxygen Sensor #12	V
Air fuel ratio correction by rear oxygen sensor	Short term fuel trim #12	%
On-board diagnostic system	OBD System	—
Oxygen sensor #11	Oxygen sensor #11	Support
Oxygen sensor #12	Oxygen sensor #12	Support
A/F sensor #11	A/F sensor #11	—

**NOTE:**

For detailed operation procedure, refer to the SUBARU SELECT MONITOR OPERATION MANUAL.

# SUBARU SELECT MONITOR

## ENGINE (DIAGNOSTICS)

---

### 6. READ FREEZE FRAME DATA FOR ENGINE. (OBD MODE)

- 1) On the «Main Menu» display screen, select the {Each System Check} and press the [YES] key.
  - 2) On the «System Selection Menu» display screen, select the {Engine Control System} and press the [YES] key.
  - 3) Press the [YES] key after displayed the information of engine type.
  - 4) On the «Engine Diagnosis» display screen, select the {OBD System} and press the [YES] key.
  - 5) On the «OBD Menu» display screen, select the {Freeze Frame Data} and press the [YES] key.
- A list of the support data is shown in the following table.

Contents	Display	Unit of measure
Diagnostic trouble code (DTC) for freeze frame data	Freeze frame data	DTC
Air fuel ratio control system for bank 1	Fuel system for Bank1	ON or OFF
Engine load data	Engine Load	%
Engine coolant temperature signal	Coolant Temp.	°C or °F
Short term fuel trim by front oxygen (A/F) sensor	Short term fuel trim B1	%
Long term fuel trim by front oxygen (A/F) sensor	Long term fuel trim B1	%
Intake manifold absolute pressure signal	Mani. Absolute Pressure	mmHg or kPa or inHg or psi
Engine speed signal	Engine Speed	rpm
Vehicle speed signal	Vehicle Speed	km/h or MPH

#### NOTE:

For detailed operation procedure, refer to the SUBARU SELECT MONITOR OPERATION MANUAL.

## 7. LED OPERATION MODE FOR ENGINE

- 1) On the «Main Menu» display screen, select the {Each System Check} and press the [YES] key.
- 2) On the «System Selection Menu» display screen, select the {Engine Control System} and press the [YES] key.
- 3) Press the [YES] key after displayed the information of engine type.
- 4) On the «Engine Diagnosis» display screen, select the {Current Data Display & Save} and press the [YES] key.
- 5) On the «Data Display Menu» display screen, select the {Data & LED Display} and press the [YES] key.
- 6) Using the scroll key, move the display screen up or down until the desired data is shown.
  - A list of the support data is shown in the following table.

Contents	Display	Message	LED "ON" requirements
Ignition switch signal	Ignition Switch	ON or OFF	When ignition switch is turned ON.
Test mode connector signal	Test Mode Signal	ON or OFF	When test mode connector is connected.
Neutral position switch signal	Neutral Position Switch	ON or OFF	When neutral position signal is entered.
Air conditioning switch signal	A/C Switch	ON or OFF	When air conditioning switch is turned ON.
Air conditioning relay signal	A/C Relay	ON or OFF	When air conditioning relay is in function.
Radiator main fan relay signal	Radiator Fan Relay #1	ON or OFF	When radiator main fan relay is in function.
Fuel pump relay signal	Fuel Pump Relay	ON or OFF	When fuel pump relay is in function.
Knocking signal	Knocking Signal	ON or OFF	When knocking signal is entered.
Radiator sub fan relay signal	Radiator Fan Relay #2	ON or OFF	When radiator sub fan relay is in function.
Engine torque control signal #1	Torque Control Signal #1	ON or OFF	When engine torque control signal 1 is entered.
Engine torque control signal #2	Torque Control Signal #2	ON or OFF	When engine torque control signal 2 is entered.
Engine torque control permission signal	Torque Control Permit	ON or OFF	When engine torque control permission signal is entered.
Front oxygen (A/F) sensor rich signal	Front O <sub>2</sub> Rich Signal #1	ON or OFF	When front oxygen (A/F) sensor mixture ratio is rich.
Rear oxygen sensor rich signal	Rear O <sub>2</sub> Rich Signal	ON or OFF	When rear oxygen sensor mixture ratio is rich.
Starter switch signal	Starter Switch Signal	ON or OFF	When starter switch signal is entered.
Idle switch signal	Idle Switch Signal	ON or OFF	When idle switch signal is entered.
Crankshaft position sensor signal	Crankshaft Position Sig.	ON or OFF	When crankshaft position sensor signal is entered.
Camshaft position sensor signal	Camshaft Position Sig.	ON or OFF	When camshaft position sensor signal is entered.

**NOTE:**

For detailed operation procedure, refer to the SUBARU SELECT MONITOR OPERATION MANUAL.

# SUBARU SELECT MONITOR

## ENGINE (DIAGNOSTICS)

### 8. READ CURRENT DATA FOR AT.

- 1) On the «Main Menu» display screen, select the {Each System Check} and press the [YES] key.
- 2) On the «System Selection Menu» display screen, select the {Transmission Control System} and press the [YES] key.
- 3) Press the [YES] key after displayed the information of transmission type.
- 4) On the «Transmission Diagnosis» display screen, select the {Current Data Display & Save} and press the [YES] key.
- 5) On the «Data Display Menu» display screen, select the {Data Display} and press the [YES] key.
- 6) Using the scroll key, move the display screen up or down until the desired data is shown.
  - A list of the support data is shown in the following table.

Contents	Display	Unit of measure
Battery voltage	Battery Voltage	V
Rear vehicle speed sensor signal	Vehicle Speed #1	km/h or MPH
Front vehicle speed sensor signal	Vehicle Speed #2	km/h or MPH
Engine speed signal	Engine Speed	rpm
Automatic transmission fluid temperature signal	ATF Temp.	°C or °F
Throttle position signal	Throttle Sensor Voltage	V
Gear position	Gear Position	—
Line pressure control duty ratio	Line Pressure Duty Ratio	%
Lock up clutch control duty ratio	Lock Up Duty Ratio	%
Transfer clutch control duty ratio	Transfer Duty Ratio	%
Power supply for throttle position sensor	Throttle Sensor Power	V
Torque converter turbine speed signal	AT Turbine Speed	rpm
2-4 brake timing pressure control duty ratio	2-4B Duty Ratio	%
Intake manifold pressure sensor voltage	Mani. Pressure Voltage	V
2 wheel drive switch signal	2WD Switch	ON or OFF
Kick down switch signal	Kick Down Switch	ON or OFF
Stop lamp switch signal	Stop Lamp Switch	ON or OFF
Anti lock brake system signal	ABS Signal	ON or OFF
Cruise control system signal	Cruise Control Signal	ON or OFF
Neutral/Parking range signal	N/P Range Signal	ON or OFF
Reverse range signal	R Range Signal	ON or OFF
Drive range signal	D Range Signal	ON or OFF
3rd range signal	3rd Range Signal	ON or OFF
2nd range signal	2nd Range Signal	ON or OFF
1st range signal	1st Range Signal	ON or OFF
Shift control solenoid A	Shift Solenoid #1	ON or OFF
Shift control solenoid B	Shift Solenoid #2	ON or OFF
Torque control output signal #1	Torque Control Signal #1	ON or OFF
Torque control output signal #2	Torque Control Signal #2	ON or OFF
Torque control cut signal	Torque Control Cut Sig.	ON or OFF
2-4 brake timing control solenoid valve	2-4 Brake Timing Sol.	ON or OFF
Low clutch timing control solenoid valve	Low Clutch Timing Sol.	ON or OFF
Automatic transmission diagnosis indicator lamp	AT Diagnosis Lamp	ON or OFF

#### NOTE:

For detailed operation procedure, refer to the SUBARU SELECT MONITOR OPERATION MANUAL.

## 11. Read Diagnostic Trouble Code

### A: OPERATION

#### 1. SUBARU SELECT MONITOR (NORMAL MODE)

- 1) On the «Main Menu» display screen, select the {Each System Check} and press the [YES] key.
- 2) On the «System Selection Menu» display screen, select the {Engine Control System} and press the [YES] key.
- 3) Press the [YES] key after displayed the information of engine type.
- 4) On the «Engine Diagnosis» display screen, select the {Diagnostic Code(s) Display} and press the [YES] key.
- 5) On the «Diagnostic Code(s) Display» display screen, select the {Current Diagnostic Code(s)} or {History Diagnostic Code(s)} and press the [YES] key.

NOTE:

- For detailed operation procedure, refer to the SUBARU SELECT MONITOR OPERATION MANUAL.
- For detailed concerning diagnostic trouble codes, refer to the List of Diagnostic Trouble Code (DTC). <Ref. to EN(SOHC)-75, List of Diagnostic Trouble Code (DTC).>

#### 2. SUBARU SELECT MONITOR (OBD MODE)

- 1) On the «Main Menu» display screen, select the {2. Each System Check} and press the [YES] key.
- 2) On the «System Selection Menu» display screen, select the {Engine Control System} and press the [YES] key.
- 3) Press the [YES] key after displayed the information of engine type.
- 4) On the «Engine Diagnosis» display screen, select the {OBD System} and press the [YES] key.
- 5) On the «OBD Menu» display screen, select the {Diagnosis Code(s) Display} and press the [YES] key.
- 6) Make sure that a diagnostic trouble code (DTC) is shown on the display screen.

NOTE:

- For detailed operation procedure, refer to the SUBARU SELECT MONITOR OPERATION MANUAL.
- For detailed concerning diagnostic trouble codes, refer to the List of Diagnostic Trouble Code (DTC). <Ref. to EN(SOHC)-75, List of Diagnostic Trouble Code (DTC).>

#### 3. OBD-II GENERAL SCAN TOOL

Refers to data denoting emission-related powertrain diagnostic trouble codes.

For details concerning diagnostic trouble codes, refer to the List of Diagnostic Trouble Code (DTC). <Ref. to EN(SOHC)-75, List of Diagnostic Trouble Code (DTC).>

NOTE:

Refer to OBD-II general scan tool manufacturer's instruction manual to access emission-related powertrain diagnostic trouble codes (MODE \$03).

# INSPECTION MODE

ENGINE (DIAGNOSTICS)

## 12. Inspection Mode

### A: OPERATION

Carry out trouble diagnosis shown in the following DTC table.

When performing trouble diagnosis which is not shown in the DTC table, refer to the next item Drive cycle.

<Ref. to EN(SOHC)-45, Drive Cycle.>

DTC No.	Item
P0031	HO2S Heater Control Circuit Low (Bank 1 Sensor 1)
P0032	HO2S Heater Control Circuit High (Bank 1 Sensor 1)
P0037	HO2S Heater Control Circuit Low (Bank 1 Sensor 2)
P0038	HO2S Heater Control Circuit High (Bank 1 Sensor 2)
P0068	Manifold Absolute Pressure/Barometric Pressure Circuit Range/Performance
P0107	Manifold Absolute Pressure/Barometric Pressure Circuit Low Input
P0108	Manifold Absolute Pressure/Barometric Pressure Circuit High Input
P0112	Intake Air Temperature Circuit Low Input
P0113	Intake Air Temperature Circuit High Input
P0117	Engine Coolant Temperature Circuit Low Input
P0118	Engine Coolant Temperature Circuit High Input
P0122	Throttle/Pedal Position Sensor/Switch "A" Circuit Low Input
P0123	Throttle/Pedal Position Sensor/Switch "A" Circuit High Input
P0129	Barometric Pressure Too Low
P0131	O <sub>2</sub> Sensor Circuit Low Voltage (Bank 1 Sensor 1)
P0132	O <sub>2</sub> Sensor Circuit High Voltage (Bank 1 Sensor 1)
P0134	O <sub>2</sub> Sensor Circuit No Activity Detected (Bank 1 Sensor 1)
P0137	O <sub>2</sub> Sensor Circuit Low Voltage (Bank 1 Sensor 2)
P0138	O <sub>2</sub> Sensor Circuit High Voltage (Bank 1 Sensor 2)
P0327	Knock Sensor 1 Circuit Low Input (Bank 1 or Single Sensor)
P0328	Knock Sensor 1 Circuit High Input (Bank 1 or Single Sensor)
P0335	Crankshaft Position Sensor "A" Circuit
P0336	Crankshaft Position Sensor "A" Circuit Range/Performance
P0340	Camshaft Position Sensor "A" Circuit (Bank 1 or Single Sensor)
P0341	Camshaft Position Sensor "A" Circuit Range/Performance (Bank 1 or Single Sensor)
P0458	Evaporative Emission Control System Purge Control Valve Circuit Low
P0462	Fuel Level Sensor Circuit Low Input
P0463	Fuel Level Sensor Circuit High Input
P0502	Vehicle Speed Sensor Circuit Low Input
P0503	Vehicle Speed Sensor Circuit High Input
P0512	Starter Request Circuit
P0513	Incorrect immobilizer key
P0519	Idle Control System Malfunction (Fail-safe)
P0565	Cruise Control Set Signal Circuit Malfunction for AT
P0604	Internal Control Module Random Access Memory (RAM) Error
P0703	Torque Converter/Brake Switch "B" Circuit
P0705	Transmission Range Sensor Circuit (PRNDL Input)
P0710	Transmission Fluid Temperature Sensor Circuit
P0716	Input/Turbine Speed Sensor Circuit
P0720	Output Speed Sensor Circuit
P0726	Engine Speed Input Circuit
P0731	Gear 1 Incorrect Ratio
P0732	Gear 2 Incorrect Ratio
P0733	Gear 3 Incorrect Ratio



# INSPECTION MODE

ENGINE (DIAGNOSTICS)

DTC No.	Item
P0734	Gear 4 Incorrect Ratio
P0741	Torque Converter Clutch Circuit Performance or Stuck Off
P0743	Torque Converter Clutch Circuit Electrical
P0748	Pressure Control Solenoid "A" Electrical
P0753	Shift Solenoid "A" Electrical
P0758	Shift Solenoid "B" Electrical
P0771	AT Low Clutch Timing Solenoid Valve Circuit Malfunction
P0778	Pressure Control Solenoid "B" Electrical
P0785	Shift/Timing Solenoid
P0851	Neutral Switch Input Circuit Low
P0852	Neutral Switch Input Circuit High
P0864	TCM Communication Circuit Range/Performance
P0865	TCM Communication Circuit Low
P0866	TCM Communication Circuit High
P1110	Atmospheric Pressure Sensor Circuit Malfunction (Low Input)
P1111	Atmospheric Pressure Sensor Circuit Malfunction (High Input)
P1492	EGR Signal Line 1 Circuit (Low)
P1493	EGR Signal Line 1 Circuit (High)
P1494	EGR Signal Line 2 Circuit (Low)
P1495	EGR Signal Line 2 Circuit (High)
P1496	EGR Signal Line 3 Circuit (Low)
P1497	EGR Signal Line 3 Circuit (High)
P1498	EGR Signal Line 4 Circuit (Low)
P1499	EGR Signal Line 4 Circuit (High)
P1510	ISC Solenoid Valve Signal #1 Circuit Malfunction (Low Input)
P1511	ISC Solenoid Valve Signal #1 Circuit Malfunction (High Input)
P1512	ISC Solenoid Valve Signal #2 Circuit Malfunction (Low Input)
P1513	ISC Solenoid Valve Signal #2 Circuit Malfunction (High Input)
P1514	ISC Solenoid Valve Signal #3 Circuit Malfunction (Low Input)
P1515	ISC Solenoid Valve Signal #3 Circuit Malfunction (High Input)
P1516	ISC Solenoid Valve Signal #4 Circuit Malfunction (Low Input)
P1517	ISC Solenoid Valve Signal #4 Circuit Malfunction (High Input)
P1518	Starter Switch Circuit Low input
P1560	Back-up Voltage Circuit Malfunction
P1570	Antenna
P1571	Reference Code Incompatibility
P1572	IMM Circuit Failure (Except Antenna Circuit)
P1574	Key Communication Failure
P1576	EGI Control Module EEPROM
P1577	IMM Control Module EEPROM
P1698	Engine Torque Control Cut Signal Circuit Malfunction (Low Input)
P1699	Engine Torque Control Cut Signal Circuit Malfunction (High Input)
P1700	Throttle Position Sensor Circuit Malfunction for AT
P1711	Engine Torque Control Signal #1 Circuit Malfunction
P1712	Engine Torque Control Signal #2 Circuit Malfunction

# INSPECTION MODE

## ENGINE (DIAGNOSTICS)

### 1. PREPARATION FOR THE INSPECTION MODE

- 1) Make sure that the fuel remains approx. half amount [20 — 40 ℓ (5.3 — 10.6 US gal, 4.4 — 8.8 Imp gal)] and the battery voltage is 12 V or more.
- 2) Raise the vehicle using a garage jack and place on safety stands or drive the vehicle onto free rollers.

#### WARNING:

- Before raising the vehicle, ensure the parking brake is applied.
- Do not use a pantograph jack in place of a safety stand.
- Secure a rope or wire to the front and rear towing or tie-down hooks to prevent the lateral runout of front wheels.
- Do not abruptly depress/release the clutch pedal or accelerator pedal during works even when engine is operating at low speeds since this may cause vehicle to jump off free rollers.
- In order to prevent the vehicle from slipping due to vibration, do not place any wooden blocks or similar items between the safety stands and the vehicle.
- Since the rear wheels will also rotate, do not place anything near them. Also, make sure that nobody goes in front of the vehicle.

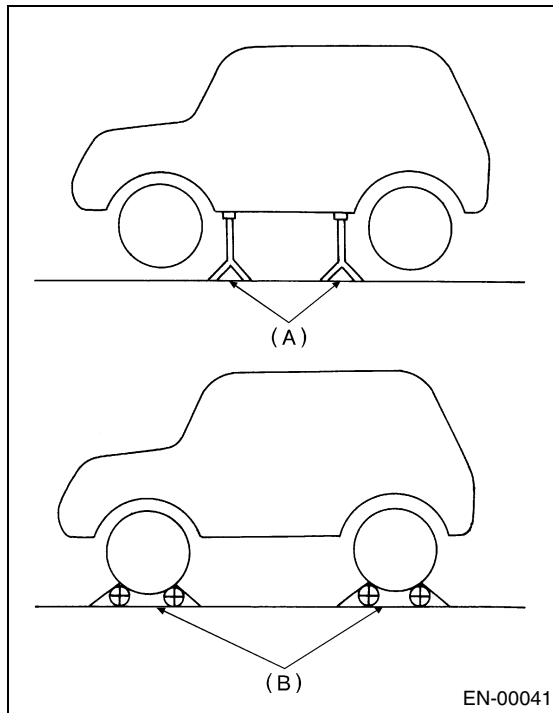

EN-00041

- (A) Safety stand  
(B) Free rollers

### 2. SUBARU SELECT MONITOR

- 1) After performing the diagnostics and clearing the memory, check for any remaining unresolved trouble data. <Ref. to EN(SOHC)-47, Clear Memory Mode.>
- 2) Warm up the engine.
- 3) Prepare the Subaru Select Monitor kit. <Ref. to EN(SOHC)-8, PREPARATION TOOL, General Description.>

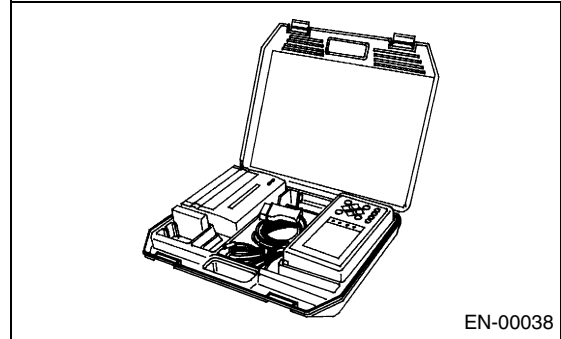

EN-00038

- 4) Connect the diagnosis cable to Subaru Select Monitor.
- 5) Insert the cartridge into Subaru Select Monitor. <Ref. to EN(SOHC)-8, PREPARATION TOOL, General Description.>

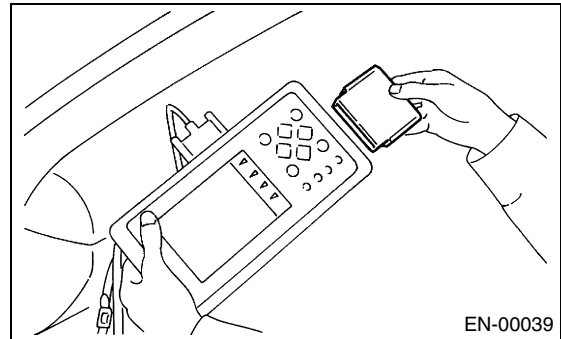

EN-00039

- 6) Connect the test mode connector (A) at the lower portion of instrument panel (on the driver's side).

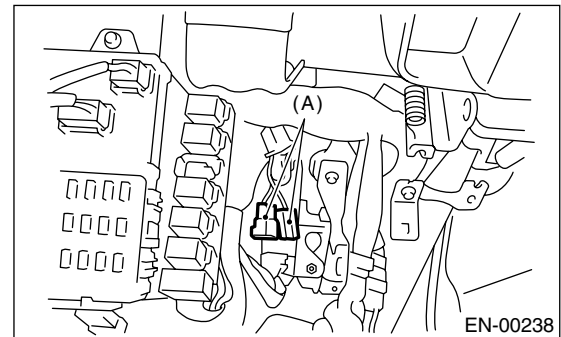

EN-00238

7) Connect the Subaru Select Monitor to data link connector.

- (1) Connect the Subaru Select Monitor to data link connector located in the lower portion of the instrument panel (on the driver's side).

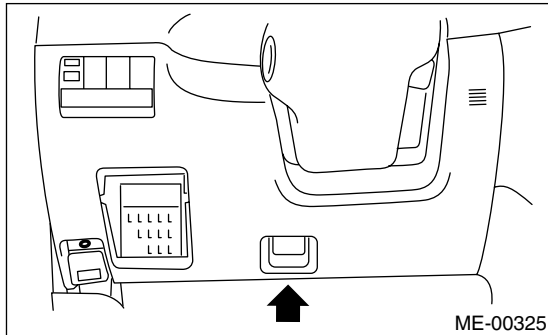

- (2) Connect the diagnosis cable to data link connector.

**CAUTION:**

**Do not connect the scan tools except for Subaru Select Monitor and OBD-II general scan tool.**

8) Turn the ignition switch to ON (engine OFF) and Subaru Select Monitor switch to ON.

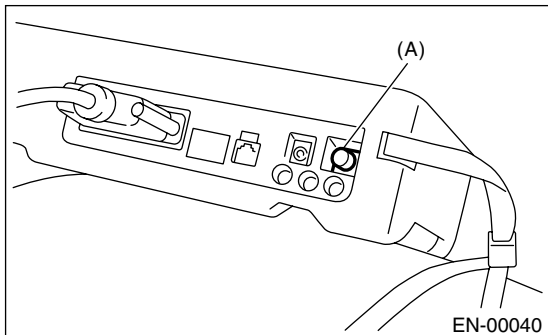

(A) Power switch

9) On the «Main Menu» display screen, select the {2. Each System Check} and press the [YES] key.

10) On the «System Selection Menu» display screen, select the {Engine Control System} and press the [YES] key.

11) Press the [YES] key after displayed the information of engine type.

12) On the «Engine Diagnosis» display screen, select the {Dealer Check Mode Procedure} and press the [YES] key.

13) When the “Perform Inspection (Dealer Check) Mode?” is shown on the display screen, press the [YES] key.

14) Perform subsequent procedures as instructed on the display screen.

- If trouble still remains in the memory, the corresponding diagnostic trouble code (DTC) appears on the display screen.

**NOTE:**

- For detailed operation procedure, refer to the SUBARU SELECT MONITOR OPERATION MANUAL.

- For detailed concerning the diagnostic trouble codes (DTCs), refer to the List of Diagnostic Trouble Code (DTC). <Ref. to EN(SOHC)-75, List of Diagnostic Trouble Code (DTC).>

- Release the parking brake.

- The speed difference between front and rear wheels may light either the ABS warning light, but this indicates no malfunctions. When the engine control diagnosis is finished, perform the ABS memory clearance procedure of self-diagnosis system.

### 3. OBD-II GENERAL SCAN TOOL

- 1) After performing the diagnostics and clearing memory, check for any remaining unresolved trouble data: <Ref. to EN(SOHC)-47, Clear Memory Mode.>

- 2) Warm up the engine.

- 3) Connect the test mode connector (A) at the lower side of instrument panel (on the driver's side).

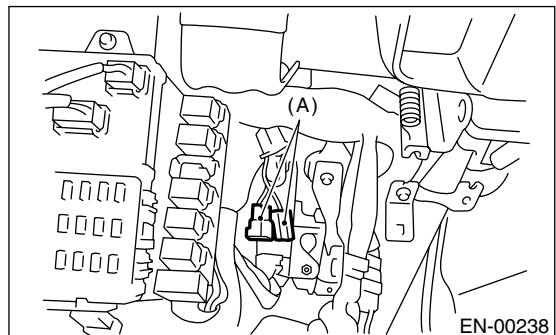

- 4) Connect the OBD-II general scan tool to its data link connector in the lower portion of instrument panel (on the driver's side).

**CAUTION:**

**Do not connect the scan tools except for Subaru Select Monitor and OBD-II general scan tool.**

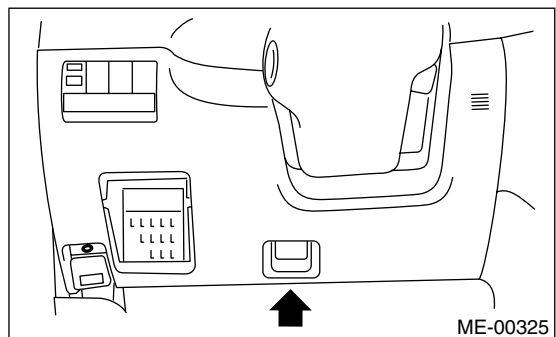

- 5) Start the engine.

## INSPECTION MODE

### ENGINE (DIAGNOSTICS)

---

#### NOTE:

- Ensure the selector lever is placed in “P” position before starting. (AT vehicles)
- Depress the clutch pedal when starting engine. (MT vehicles)

6) Using the selector lever or shift lever, turn the “P” position switch and “N” position switch to ON.

7) Depress the brake pedal to turn brake switch ON. (AT vehicles)

8) Keep the engine speed in 2,500 — 3,000 rpm range for 40 seconds.

9) Place the selector lever or shift lever in “D” position (AT vehicles) or “1st” gear (MT vehicles) and drive the vehicle at 5 to 10 km/h (3 to 6 MPH).

#### NOTE:

- On AWD vehicles, release the parking brake.
- The speed difference between front and rear wheels may light ABS warning light, but this indicates no malfunctions. When the engine control diagnosis is finished, perform the ABS memory clearance procedure of self-diagnosis system.

10) Using the OBD-II general scan tool, check for diagnostic trouble code(s) (DTC(s)) and record the result(s).

#### NOTE:

- For detailed operation procedures, refer to the OBD-II General Scan Tool Instruction Manual.
- For detailed concerning diagnostic trouble codes, refer to the List of Diagnostic Trouble Code (DTC). <Ref. to EN(SOHC)-75, List of Diagnostic Trouble Code (DTC).>

## 13. Drive Cycle

### A: OPERATION

There are three drive patterns for the trouble diagnosis. Driving in the specified pattern allows to diagnose malfunctioning items listed below. After the malfunctioning items listed below are repaired, always check whether they correctly resume their functions by driving in the required drive pattern.

#### 1. PREPARATION FOR THE DRIVE CYCLE

- 1) Make sure that the fuel remains approx. half amount [20 — 40 ℓ (5.3 — 10.6 US gal, 4.4 — 8.8 Imp gal)], and battery voltage is 12V or more.
- 2) After performing the diagnostics and cleaning memory, check for any remaining unresolved trouble data. <Ref. to EN(SOHC)-47, Clear Memory Mode.>
- 3) Separate the test mode connector.

**NOTE:**

- Except for the water temperature specified items at starting, the diagnosis is carried out after engine warm up.
- Carry out the diagnosis which is marked \* on DTC twice, then, after finishing first diagnosis, stop the engine and do second time at the same condition.

#### 2. AFTER RUNNING 20 MINUTES AT 80 KM/H (50 MPH), IDLE ENGINE FOR 1 MINUTE.

DTC No.	Item	Condition
*P0030	HO2S Heater Control Circuit Range/Performance (Bank 1 Sensor 1)	—
*P0111	Intake Air Temperature Circuit Range/Performance	Coolant temperature at start is less than 30°C (86°F).
*P0125	Insufficient Coolant Temperature for Closed Loop Fuel Control	Coolant temperature at start is less than 20°C (68°F).
*P0130	O <sub>2</sub> Sensor Circuit (Bank 1 Sensor 1)	—
*P0133	O <sub>2</sub> Sensor Circuit Slow Response (Bank 1 Sensor 1)	—
*P0420	Catalyst System Efficiency Below Threshold (Bank 1)	—
P0459	Evaporative Emission Control System Purge Control Valve Circuit High	—
*P0461	Fuel Level Sensor Performance Problem (Travel Distance)	—
*P0464	Fuel Level Sensor Circuit Intermittent	—
*P1137	O <sub>2</sub> Sensor Circuit (Bank1 Sensor1)	—

# DRIVE CYCLE

## ENGINE (DIAGNOSTICS)

### 3. IDLE FOR 10 MINUTES

**NOTE:**

Before the diagnosis, drive the vehicle at 4 km/h (6 MPH) or more.

DTC No.	Item	Condition
*P0483	Cooling Fan Rationality Check	—
*P0506	Idle Control System RPM Lower Than Expected	—
*P0507	Idle Control System RPM Higher Than Expected	—

### 4. DRIVE ACCORDING TO THE FOLLOWING DRIVE PATTERN

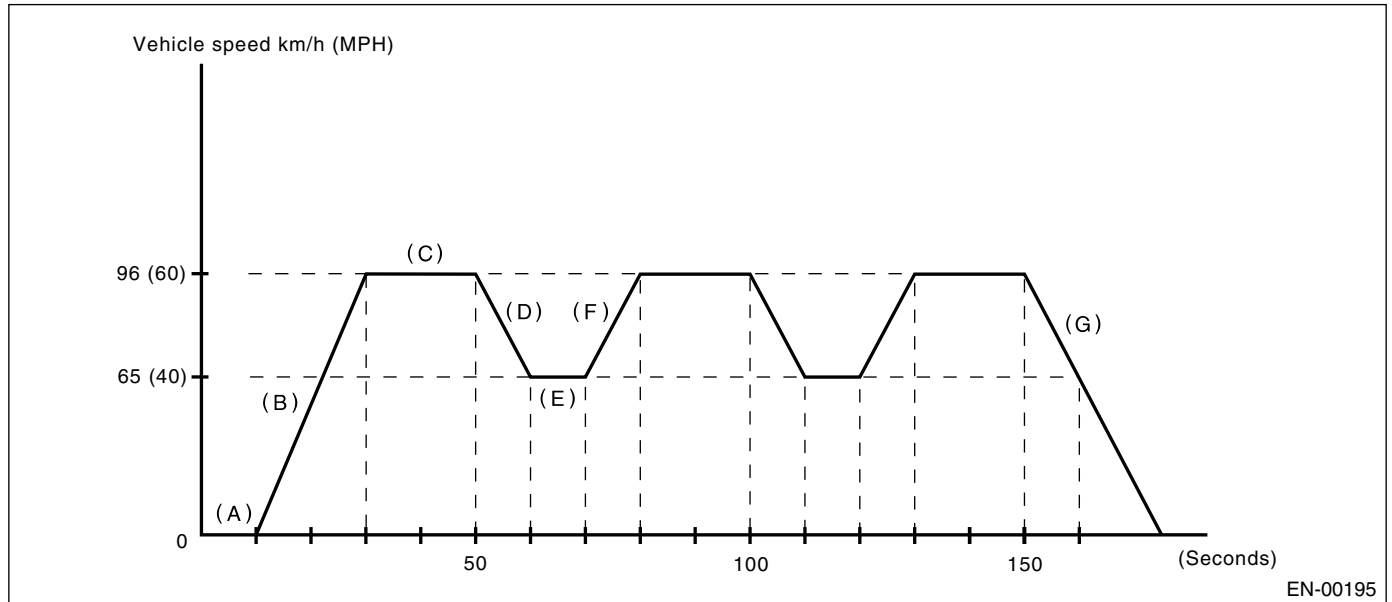

- |   |  |  |
|---|--|--|
| (A) Idle engine for 1 minute.                         | (D) Decelerate with fully closed throttle to 64 km/h (40 MPH). | (G) Stop vehicle with throttle fully closed. Stop vehicle with throttle fully closed. Stop vehicle with throttle fully closed. |
| (B) Accelerate to 97 km/h (60 MPH) within 20 seconds. | (E) Drive vehicle at 64 km/h (40 MPH) for 10 seconds.          |  |
| (C) Drive vehicle at 97 km/h (60 MPH) for 20 seconds. | (F) Accelerate to 97 km/h (60 MPH) within 10 seconds.          |  |

DTC No.	Item	Condition
*P0121	Throttle/Pedal Position Sensor/Switch "A" Circuit Range/Performance	—
*P0139	O <sub>2</sub> Sensor Circuit Slow Response (Bank 1 Sensor 2)	—
*P0171	System too Lean (Bank 1)	—
*P0172	System too Rich (Bank 1)	—
*P0301	Cylinder 1 Misfire Detected	—
*P0302	Cylinder 2 Misfire Detected	—
*P0303	Cylinder 3 Misfire Detected	—
*P0304	Cylinder 4 Misfire Detected	—
*P0400	Exhaust gas recirculation flow	—

## 14. Clear Memory Mode

### A: OPERATION

#### 1. SUBARU SELECT MONITOR (NORMAL MODE)

- 1) On the «Main Menu» display screen, select the {2. Each System Check} and press the [YES] key.
- 2) On the «System Selection Menu» display screen, select the {Engine Control System} and press the [YES] key.
- 3) Press the [YES] key after displayed the information of engine type.
- 4) On the «Engine Diagnosis» display screen, select the {Clear Memory} and press the [YES] key.
- 5) When the 'Done' and 'Turn Ignition Switch OFF' are shown on the display screen, turn the Subaru Select Monitor and ignition switch to OFF.

#### NOTE:

- After the memory has been cleared, the idle air control solenoid valve must be initialized. To do this, turn the ignition switch to the ON position. Wait 3 seconds before starting the engine.
- For detailed operation procedure, refer to the SUBARU SELECT MONITOR OPERATION MANUAL.

#### 2. SUBARU SELECT MONITOR (OBD MODE)

- 1) On the «Main Menu» display screen, select the {2. Each System Check} and press the [YES] key.
- 2) On the «System Selection Menu» display screen, select the {Engine Control System} and press the [YES] key.
- 3) Press the [YES] key after displayed the information of engine type.
- 4) On the «Engine Diagnosis» display screen, select the {OBD System} and press the [YES] key.
- 5) On the «OBD Menu» display screen, select the {4. Diagnosis Code(s) Cleared} and press the [YES] key.
- 6) When the 'Clear Diagnostic Code?' is shown on the display screen, press the [YES] key.
- 7) Turn the Subaru Select Monitor and ignition switch to OFF.

#### NOTE:

- After the memory has been cleared, the idle air control solenoid valve must be initialized. To do this, turn the ignition switch to the ON position. Wait 3 seconds before starting the engine.
- For detailed operation procedure, refer to the SUBARU SELECT MONITOR OPERATION MANUAL.

#### 3. OBD-II GENERAL SCAN TOOL

For clear memory procedures using the OBD-II general scan tool, refer to the OBD-II General Scan Tool Instruction Manual.

After the memory has been cleared, the idle air control solenoid valve must be initialized. To do this, turn the ignition switch to the ON position. Wait 3 seconds before starting the engine.

# COMPULSORY VALVE OPERATION CHECK MODE

ENGINE (DIAGNOSTICS)

## 15. Compulsory Valve Operation Check Mode

### A: OPERATION

1) Prepare the Subaru Select Monitor kit. <Ref. to EN(SOHC)-8, PREPARATION TOOL, General Description.>

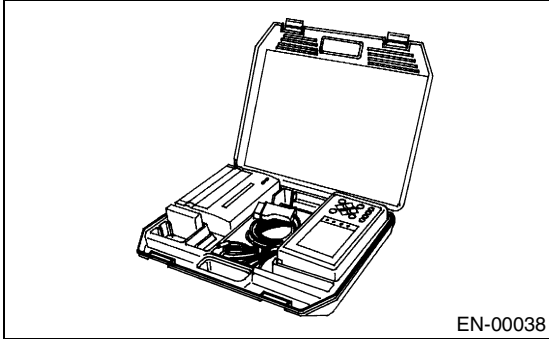

2) Connect the diagnosis cable to Subaru Select Monitor.

3) Insert the cartridge into Subaru Select Monitor. <Ref. to EN(SOHC)-8, PREPARATION TOOL, General Description.>

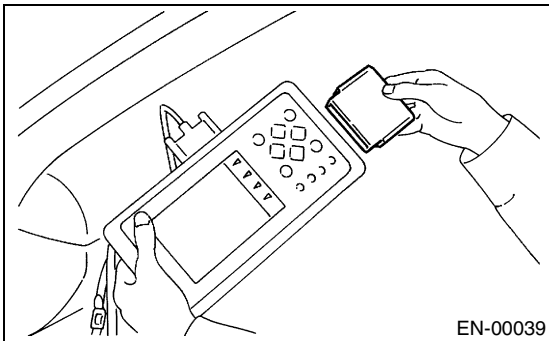

4) Connect the test mode connector (A) at the lower portion of instrument panel (on the driver's side).

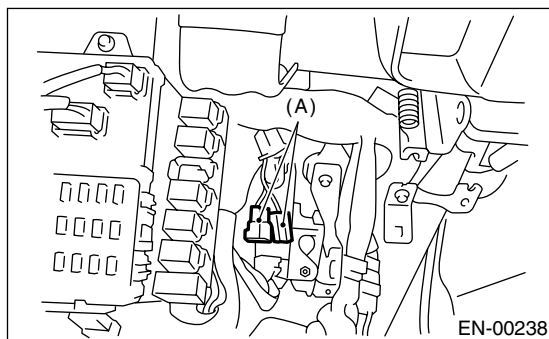

5) Connect the Subaru Select Monitor to data link connector.

(1) Connect Subaru Select Monitor to data link connector located in the lower portion of the instrument panel (on the driver's side).

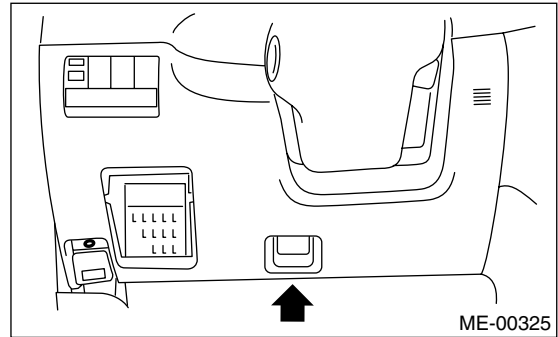

(2) Connect the diagnosis cable to data link connector.

### CAUTION:

**Do not connect scan tools except for Subaru Select Monitor and OBD-II general scan tool.**

6) Turn the ignition switch to ON (engine OFF) and Subaru Select Monitor switch to ON.

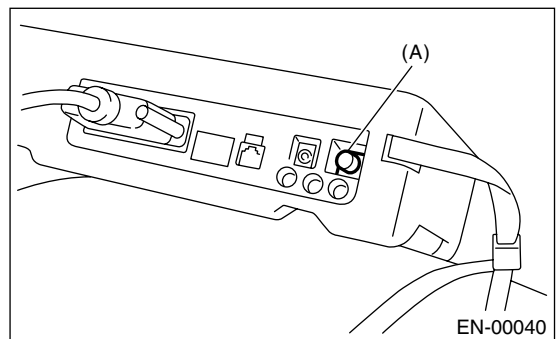

(A) Power switch

7) On the «Main Menu» display screen, select the {2. Each System Check} and press the [YES] key.

8) On the «System Selection Menu» display screen, select the {Engine Control System} and press the [YES] key.

9) Press the [YES] key after displayed the information of engine type.

10) On the «Engine Diagnosis» display screen, select the {System Operation Check Mode} and press the [YES] key.

11) On the «System Operation Check Mode» display screen, select the {Actuator ON/OFF Operation} and press the [YES] key.

12) Select the desired compulsory actuator on the «Actuator ON/OFF Operation» display screen and press the [YES] key.

13) Pressing the [NO] key completes the compulsory operation check mode. The display will then return to the «Actuator ON/OFF Operation» screen.



# COMPULSORY VALVE OPERATION CHECK MODE

ENGINE (DIAGNOSTICS)

- A list of the support data is shown in the following table.

Contents	Display
Compulsory fuel pump relay operation check	Fuel Pump Relay
Compulsory radiator fan relay operation check	Radiator Fan Relay
Compulsory air conditioning relay operation check	A/C Compressor Relay
Compulsory purge control solenoid valve operation check	CPC Solenoid Valve

## NOTE:

- The following parts will be displayed but not functional because they are not installed on the vehicle.

Display
EGR Solenoid Valve
ASV Solenoid Valve
PCV Solenoid Valve
Vent Control Solenoid Valve
FICD Solenoid
Pressure Switching Sol. 1
Pressure Switching Sol. 2
Fuel Tank Sensor Control Valve

- For detailed operation procedure, refer to the SUBARU SELECT MONITOR OPERATION MANUAL.

# ENGINE MALFUNCTION INDICATOR LAMP (MIL)

ENGINE (DIAGNOSTICS)

## 16.Engine Malfunction Indicator Lamp (MIL)

### A: PROCEDURE

1. Activation of check engine malfunction indicator lamp (MIL). <Ref. to EN(SOHC)-51, ACTIVATION OF CHECK ENGINE MALFUNCTION INDICATOR LAMP (MIL), Engine Malfunction Indicator Lamp (MIL).>
↓
2. Check engine malfunction indicator lamp (MIL) does not come on. <Ref. to EN(SOHC)-52, CHECK ENGINE MALFUNCTION INDICATOR LAMP (MIL) DOES NOT COME ON., Engine Malfunction Indicator Lamp (MIL).>
↓
3. Check engine malfunction indicator lamp (MIL) does not go off. <Ref. to EN(SOHC)-55, CHECK ENGINE MALFUNCTION INDICATOR LAMP (MIL) DOES NOT GO OFF., Engine Malfunction Indicator Lamp (MIL).>
↓
4. Check engine malfunction indicator lamp (MIL) does not blink at a cycle of 3 Hz. <Ref. to EN(SOHC)-56, CHECK ENGINE MALFUNCTION INDICATOR LAMP (MIL) DOES NOT BLINK AT A CYCLE OF 3 HZ., Engine Malfunction Indicator Lamp (MIL).>
↓
5. Check engine malfunction indicator lamp (MIL) remains blinking at a cycle of 3 Hz. <Ref. to EN(SOHC)-58, CHECK ENGINE MALFUNCTION INDICATOR LAMP (MIL) REMAINS BLINKING AT A CYCLE OF 3 HZ., Engine Malfunction Indicator Lamp (MIL).>

# ENGINE MALFUNCTION INDICATOR LAMP (MIL)

ENGINE (DIAGNOSTICS)

## B: ACTIVATION OF CHECK ENGINE MALFUNCTION INDICATOR LAMP (MIL)

1) When the ignition switch is turned to ON (engine off), the CHECK ENGINE malfunction indicator lamp (MIL) (1) in the combination meter illuminates.

### NOTE:

If the MIL does not illuminate, perform diagnostics of the CHECK ENGINE light circuit or the combination meter circuit. <Ref. to EN(SOHC)-52, CHECK ENGINE MALFUNCTION INDICATOR LAMP (MIL) DOES NOT COME ON., Engine Malfunction Indicator Lamp (MIL).>

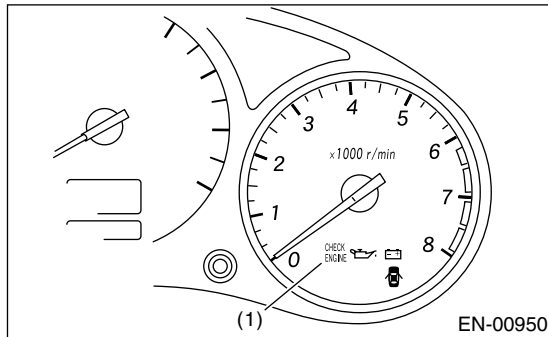

2) After starting the engine, the MIL goes out. If it does not, either the engine or the emission control system is malfunctioning.

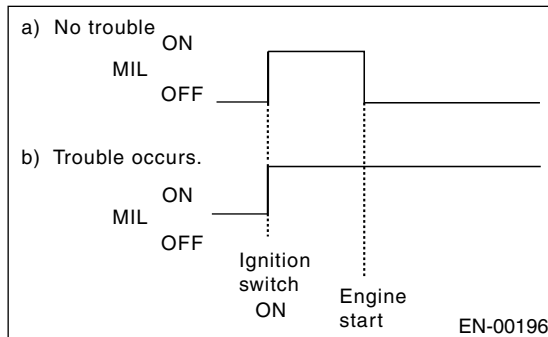

3) If the diagnosis system senses a misfire which could damage the catalyzer, the MIL will blink at a cycle of 1 Hz.

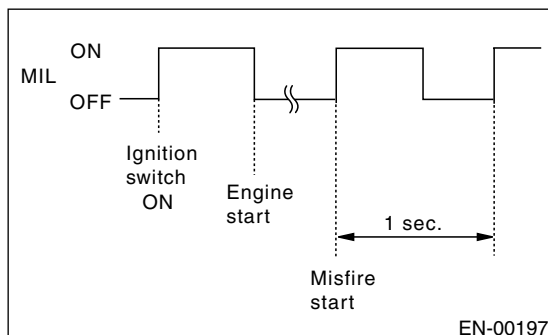

4) When the ignition switch is turned to ON (engine off) or to "START" with the test mode connector connected, the MIL blinks at a cycle of 3 Hz.

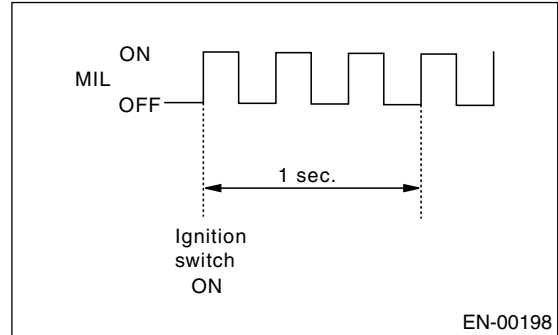

# ENGINE MALFUNCTION INDICATOR LAMP (MIL)

ENGINE (DIAGNOSTICS)

## C: CHECK ENGINE MALFUNCTION INDICATOR LAMP (MIL) DOES NOT COME ON.

### • DIAGNOSIS:

- The CHECK ENGINE malfunction indicator lamp (MIL) circuit is open or shorted.

### • TROUBLE SYMPTOM:

- When the ignition switch is turned ON (engine OFF), MIL does not come on.

### • WIRING DIAGRAM:

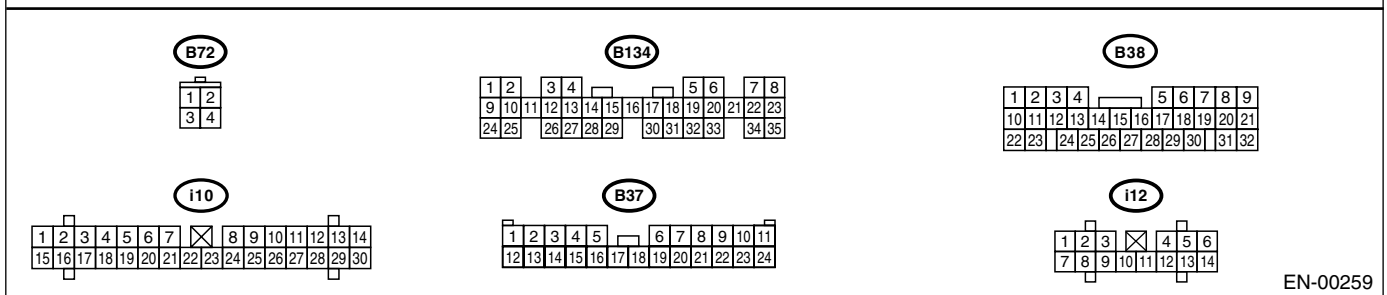
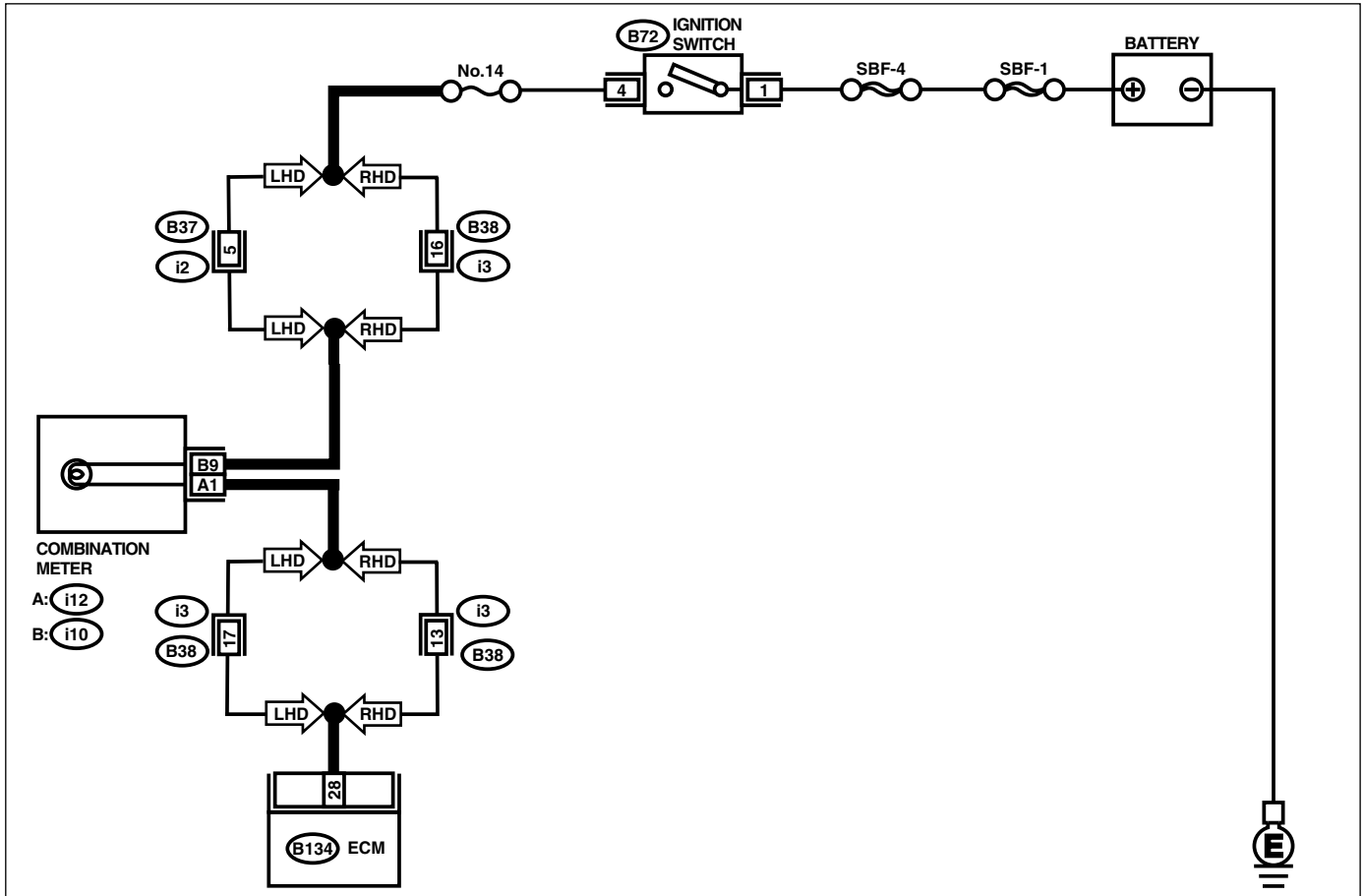

EN-00259

Step	Check	Yes	No
<b>1</b> <b>CHECK OUTPUT SIGNAL FROM ECM.</b> 1) Turn the ignition switch to ON. 2) Measure the voltage between ECM connector and chassis ground. <b>Connector &amp; terminal</b> <b>(B134) No. 28 (+) — Chassis ground (-):</b> Is the measured value less than specified value?	1 V	Go to step 4.	Go to step 2.

# ENGINE MALFUNCTION INDICATOR LAMP (MIL)

ENGINE (DIAGNOSTICS)

Step	Check	Yes	No
<b>2 CHECK POOR CONTACT.</b> Does the MIL illuminate when shaking or pulling ECM connector and harness?	MIL illuminates.	Repair poor contact in ECM connector.	Go to step 3.
<b>3 CHECK ECM CONNECTOR.</b> Is the ECM connector correctly connected?	Correctly connected.	Replace the ECM. <Ref. to FU(SOHC)-46, Engine Control Module.>	Repair connection of ECM connector.
<b>4 CHECK HARNESS BETWEEN COMBINATION METER AND ECM CONNECTOR.</b> 1)Turn the ignition switch to OFF. 2)Remove the combination meter. <Ref. to IDI-12, Combination Meter Assembly.> 3)Disconnect the connector from ECM and combination meter. 4)Measure the resistance of harness between ECM and combination meter connector. <b>Connector &amp; terminal</b> <b>(B134) No. 28 — (i12) No. 1:</b> Is the measured value less than specified value?	1 Ω	Go to step 5.	Repair harness and connector. NOTE: In this case, repair the following: <ul style="list-style-type: none"> <li>• Open circuit in harness between ECM and combination meter connector</li> <li>• Poor contact in coupling connector</li> </ul>
<b>5 CHECK POOR CONTACT.</b> Check poor contact in combination meter connector. Is there poor contact in combination meter connector?	Poor contact occurs.	Repair poor contact in combination meter connector.	Go to step 6.
<b>6 CHECK HARNESS BETWEEN COMBINATION METER AND IGNITION SWITCH CONNECTOR.</b> 1)Turn the ignition switch to ON. 2)Measure the voltage between combination meter connector and chassis ground. <b>Connector &amp; terminal</b> <b>(i12) No. 9 (+) — Chassis ground (-):</b> Is the measured value more than specified value?	10 V	Go to step 7.	Check the following and repair if necessary. NOTE: <ul style="list-style-type: none"> <li>• Broken down ignition relay.</li> <li>• Blown out fuse (No. 5).</li> <li>• If replaced fuse (No. 5) blows easily, check the harness for short circuit of harness between fuse (No. 5) and ignition relay connector.</li> <li>• Open or short circuit in harness between fuse (No. 5) and battery terminal</li> <li>• Open circuit in harness between fuse (No. 5) and ignition relay connector</li> <li>• Poor contact in ignition relay connector</li> <li>• Poor contact in ignition switch connector</li> </ul>

# ENGINE MALFUNCTION INDICATOR LAMP (MIL)

ENGINE (DIAGNOSTICS)

	Step	Check	Yes	No
7	<b>CHECK LAMP BULB.</b> Remove the engine malfunction indicator lamp bulb. Is the lamp bulb condition OK?	Lamp bulb is OK.	Repair combination meter connector.	Replace the lamp bulb.

# ENGINE MALFUNCTION INDICATOR LAMP (MIL)

ENGINE (DIAGNOSTICS)

## D: CHECK ENGINE MALFUNCTION INDICATOR LAMP (MIL) DOES NOT GO OFF.

### • DIAGNOSIS:

- The CHECK ENGINE malfunction indicator lamp (MIL) circuit is shorted.

### • TROUBLE SYMPTOM:

- Although MIL comes on when the engine runs, trouble code is not shown on the Subaru select monitor or OBD-II general scan tool display.

### • WIRING DIAGRAM:

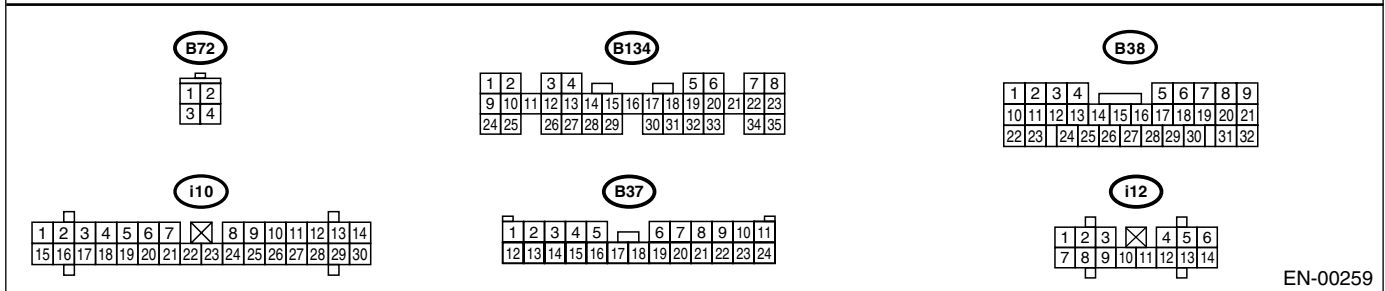
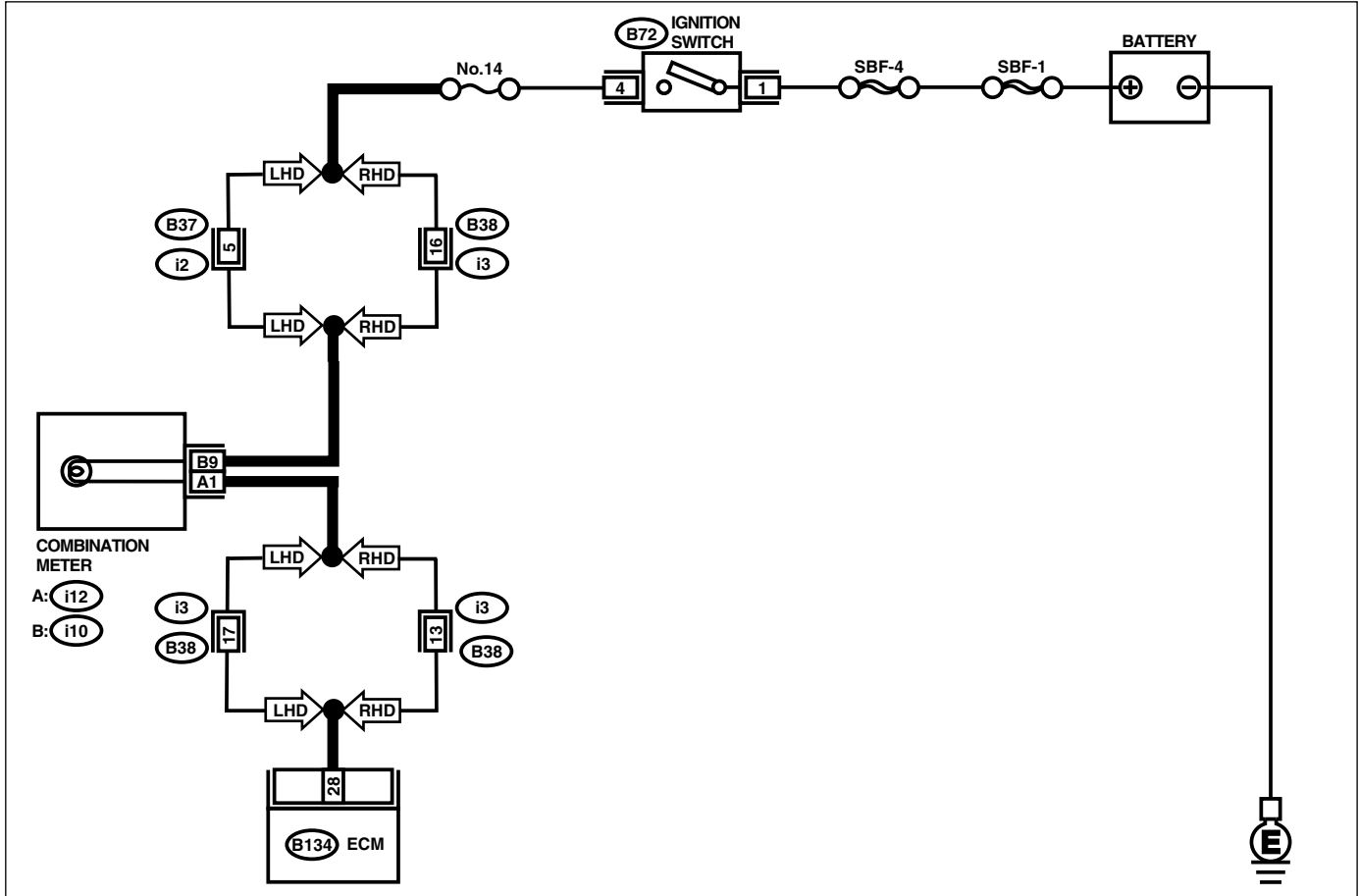

EN-00259

Step	Check	Yes	No
<b>1 CHECK HARNESS BETWEEN COMBINATION METER AND ECM CONNECTOR.</b> 1) Turn the ignition switch to OFF. 2) Disconnect the connector from ECM. 3) Turn the ignition switch to ON. Does the MIL illuminate?	MIL illuminates.	Repair short circuit in harness between combination meter and ECM connector.	Replace the ECM. <Ref. to FU(SOHC)-46, Engine Control Module.>

# ENGINE MALFUNCTION INDICATOR LAMP (MIL)

ENGINE (DIAGNOSTICS)

## E: CHECK ENGINE MALFUNCTION INDICATOR LAMP (MIL) DOES NOT BLINK AT A CYCLE OF 3 HZ.

### • DIAGNOSIS:

- The CHECK ENGINE malfunction indicator lamp (MIL) circuit is open or shorted.
- Test mode connector circuit is in open.

### • TROUBLE SYMPTOM:

- When in inspection mode, MIL does not blink at a cycle of 3 Hz.

### • WIRING DIAGRAM:

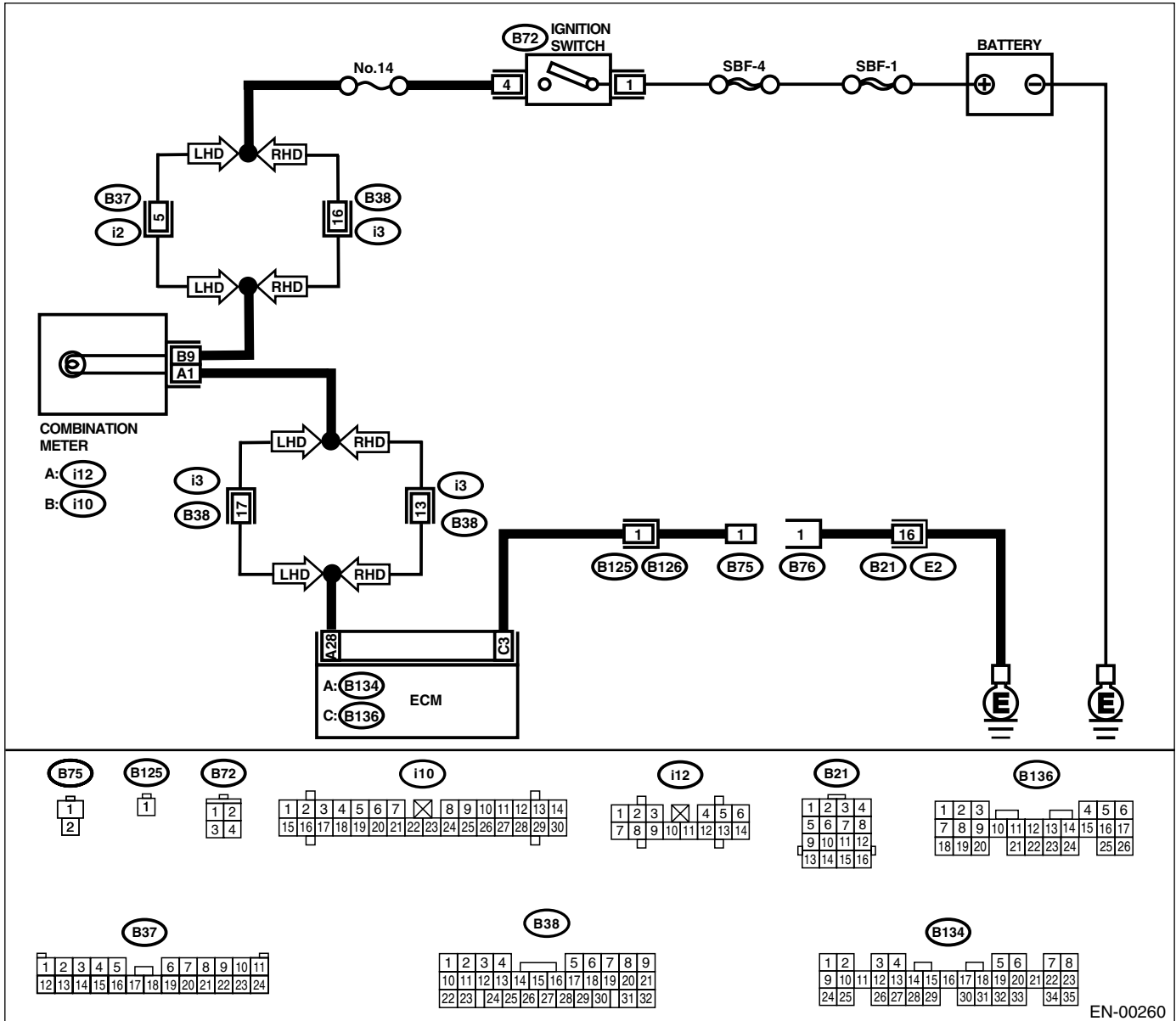

EN-00260



# ENGINE MALFUNCTION INDICATOR LAMP (MIL)

ENGINE (DIAGNOSTICS)

Step	Check	Yes	No
<b>1 CHECK STATUS OF CHECK ENGINE MALFUNCTION INDICATOR LAMP (MIL).</b> 1) Turn the ignition switch to OFF. 2) Disconnect the test mode connector. 3) Turn the ignition switch to ON. (engine OFF) Does the MIL illuminate?	MIL illuminates.	Go to step 2.	Repair the MIL circuit. <Ref. to EN(SOHC)-52, CHECK ENGINE MALFUNCTION INDICATOR LAMP (MIL) DOES NOT COME ON., Engine Malfunction Indicator Lamp (MIL).>
<b>2 CHECK HARNESS BETWEEN COMBINATION METER AND ECM CONNECTOR.</b> 1) Turn the ignition switch to OFF. 2) Disconnect the connector from ECM. 3) Turn the ignition switch to ON. Does the MIL illuminate?	MIL illuminates.	Repair ground short circuit in harness between combination meter and ECM connector.	Go to step 3.
<b>3 CHECK HARNESS BETWEEN TEST MODE CONNECTOR AND CHASSIS GROUND.</b> 1) Turn the ignition switch to OFF. 2) Disconnect the connector from ECM. 3) Measure the resistance of harness between test mode connector and chassis ground. <i><b>Connector &amp; terminal</b></i> <i><b>(B76) No. 1 — Chassis ground:</b></i> Is the measured value less than specified value?	1 Ω	Go to step 4.	Repair harness and connector. NOTE: In this case, repair the following: • Open circuit in harness between test mode connector and chassis ground
<b>4 CHECK POOR CONTACT.</b> Check poor contact in ECM connector. Is there poor contact in ECM connector?	Poor contact occurs.	Repair poor contact in ECM connector.	Go to step 5.
<b>5 CHECK HARNESS BETWEEN ECM AND TEST MODE CONNECTOR.</b> 1) Connect the test mode connector. 2) Measure the resistance of harness between ECM and chassis ground. <i><b>Connector &amp; terminal</b></i> <i><b>(B136) No. 3 — Chassis ground:</b></i> Is the measured value less than specified value?	1 Ω	Go to step 6.	Repair open circuit in harness between ECM and test mode connector.
<b>6 CHECK POOR CONTACT.</b> Check poor contact in ECM connector. Is there poor contact in ECM connector?	Poor contact occurs.	Repair poor contact in ECM connector.	Replace the ECM. <Ref. to FU(SOHC)-46, Engine Control Module.>

# ENGINE MALFUNCTION INDICATOR LAMP (MIL)

ENGINE (DIAGNOSTICS)

## F: CHECK ENGINE MALFUNCTION INDICATOR LAMP (MIL) REMAINS BLINKING AT A CYCLE OF 3 HZ.

• **DIAGNOSIS:**

- Test mode connector circuit is shorted.

• **TROUBLE SYMPTOM:**

- MIL blinks at a cycle of 3 Hz when the ignition switch is turned to ON.

• **WIRING DIAGRAM:**

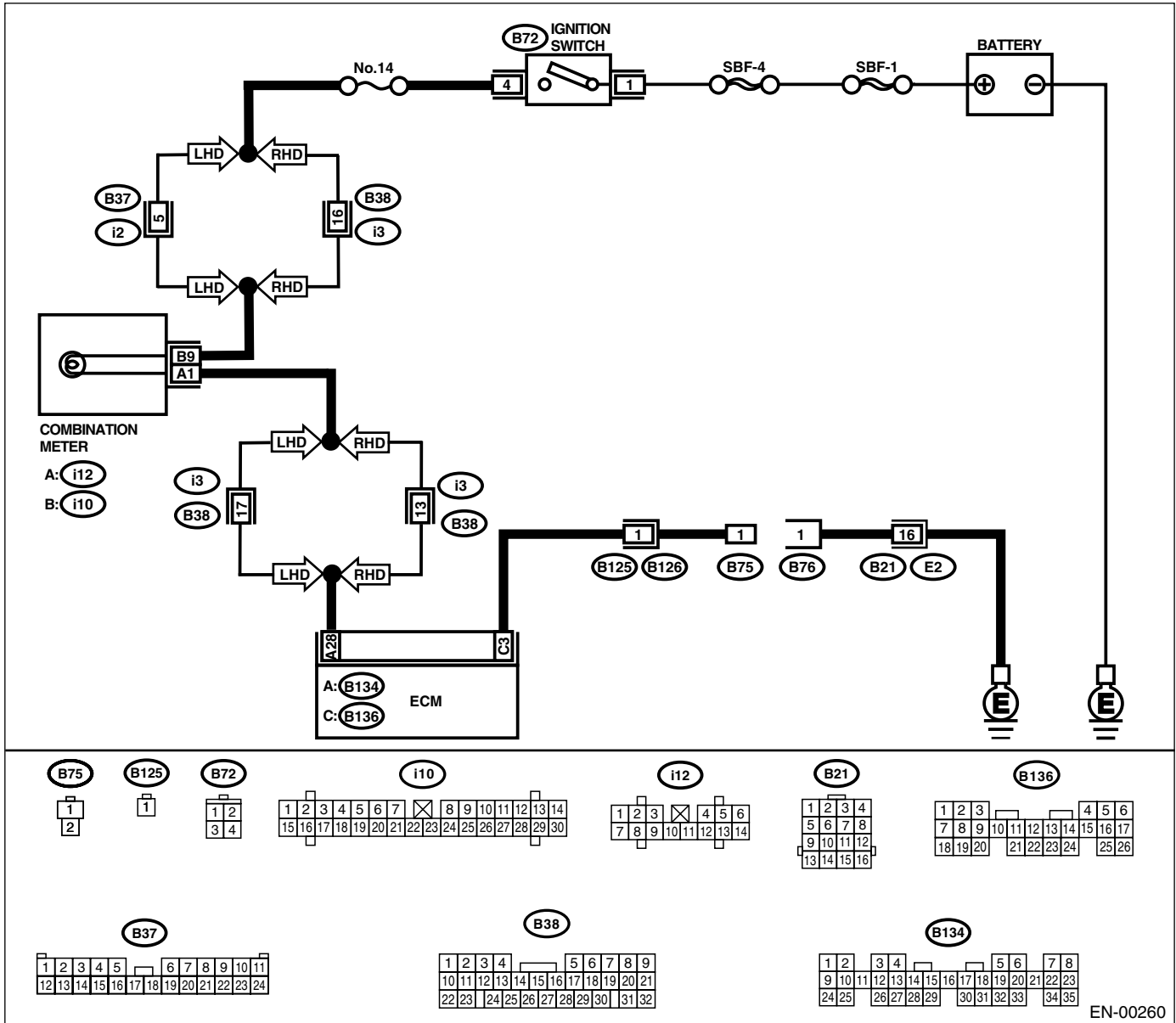

EN-00260

# ENGINE MALFUNCTION INDICATOR LAMP (MIL)

ENGINE (DIAGNOSTICS)

	Step	Check	Yes	No
1	<b>CHECK TEST MODE CONNECTOR.</b> 1)Disconnect the test mode connector. 2)Turn the ignition switch to ON. Does the MIL blink?	MIL blinks.	Go to step 2.	System is in good order.  NOTE: MIL blinks at a cycle of 3 Hz when test mode connector is connected.
2	<b>CHECK HARNESS BETWEEN ECM CONNECTOR AND ENGINE GROUNDING TERMINAL.</b> 1)Turn the ignition switch to OFF. 2)Disconnect the connector from ECM. 3)Measure the resistance of harness between ECM connector and chassis ground. <b>Connector &amp; terminal</b> <b>(B136) No. 3 — Chassis ground:</b> Is the measured value less than specified value?	5 Ω	Repair short circuit in harness between ECM and test mode connector.	Replace the ECM. <Ref. to FU(SOHC)-46, Engine Control Module.>

# DIAGNOSTICS FOR ENGINE STARTING FAILURE

ENGINE (DIAGNOSTICS)

---

## 17. Diagnostics for Engine Starting Failure

### A: PROCEDURE

1. Inspection of starter motor circuit. <Ref. to EN(SOHC)-61, STARTER MOTOR CIRCUIT, Diagnostics for Engine Starting Failure.>
↓
2. Inspection of ECM power supply and ground line. <Ref. to EN(SOHC)-64, CONTROL MODULE POWER SUPPLY AND GROUND LINE, Diagnostics for Engine Starting Failure.>
↓
3. Inspection of ignition control system. <Ref. to EN(SOHC)-67, IGNITION CONTROL SYSTEM, Diagnostics for Engine Starting Failure.>
↓
4. Inspection of fuel pump circuit. <Ref. to EN(SOHC)-70, FUEL PUMP CIRCUIT, Diagnostics for Engine Starting Failure.>
↓
5. Inspection of fuel injector circuit. <Ref. to EN(SOHC)-73, FUEL INJECTOR CIRCUIT, Diagnostics for Engine Starting Failure.>

# DIAGNOSTICS FOR ENGINE STARTING FAILURE

ENGINE (DIAGNOSTICS)

## B: STARTER MOTOR CIRCUIT

### CAUTION:

After repair or replacement of faulty parts, conduct CLEAR MEMORY MODE <Ref. to EN(SOHC)-47, Clear Memory Mode.> and INSPECTION MODE <Ref. to EN(SOHC)-40, Inspection Mode.>.

### • WIRING DIAGRAM:

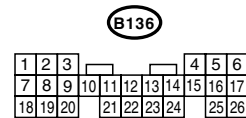
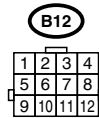
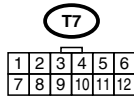
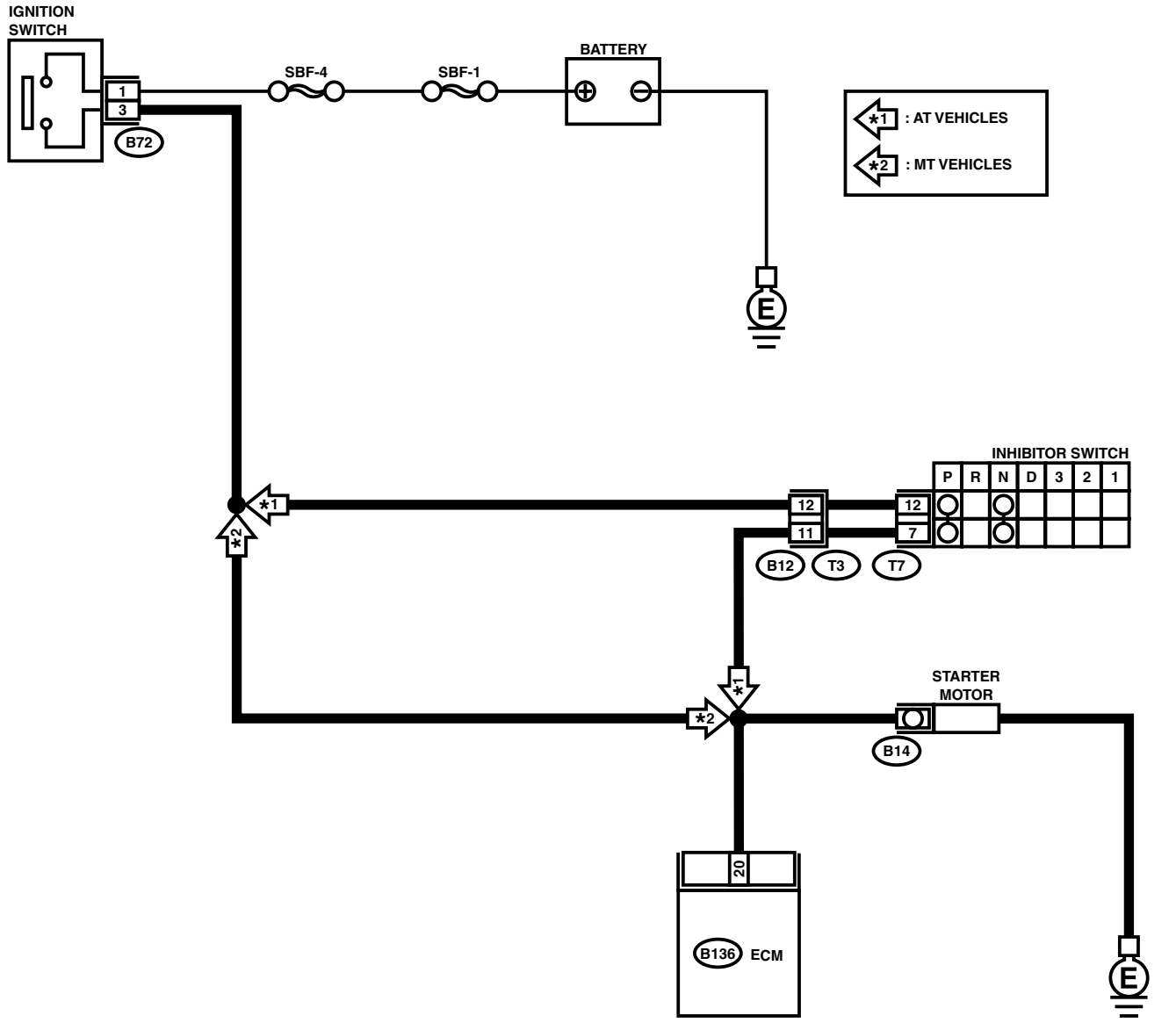

EN-00261

# DIAGNOSTICS FOR ENGINE STARTING FAILURE

## ENGINE (DIAGNOSTICS)

Step	Check	Yes	No
<b>1 CHECK BATTERY.</b> Is the measured value more than specified value?	12 V	Go to step 2.	Charge or replace the battery.
<b>2 CHECK INPUT SIGNAL FOR STARTER MOTOR.</b> 1) Turn the ignition switch to OFF. 2) Disconnect the connector from starter motor. 3) Turn the ignition switch to ST. 4) Measure the power supply voltage between starter motor connector terminal and engine ground. <b>Connector &amp; terminal</b> <b>(B14) No. 1 (+) — Engine ground (-):</b> Is the measured value more than specified value?  NOTE: • On AT vehicles, place the selector lever in the "P" or "N" position. • On MT vehicles, depress the clutch pedal.	10 V	Go to step 3.	Go to step 4.
<b>3 CHECK GROUND CIRCUIT OF STARTER MOTOR.</b> 1) Turn the ignition switch to OFF. 2) Disconnect the terminal from starter motor. 3) Measure the resistance of ground cable between ground cable terminal and engine ground. Is the measured value less than specified value?	5 Ω	Check the starter motor. <Ref. to SC(SOHC)-6, Starter.>	Repair open circuit of ground cable.
<b>4 CHECK HARNESS BETWEEN BATTERY AND IGNITION SWITCH CONNECTOR.</b> 1) Disconnect the connector from ignition switch. 2) Measure the power supply voltage between ignition switch connector and chassis ground. <b>Connector &amp; terminal</b> <b>(B72) No. 1 (+) — Chassis ground (-):</b> Is the measured value more than specified value?	10 V	Go to step 5.	Repair open circuit in harness between ignition switch and battery, and check fuse SBF No. 4 and SBF No. 1.
<b>5 CHECK IGNITION SWITCH.</b> 1) Disconnect the connector from ignition switch. 2) Measure the resistance between ignition switch terminals while turning ignition switch to the "ST" position. <b>Terminals</b> <b>No. 1 — No. 3:</b> Is the measured value less than specified value?	5 Ω	Go to step 6.	Replace the ignition switch.
<b>6 CHECK TRANSMISSION TYPE.</b> Is the target AT vehicle?	Target is AT vehicle.	Go to step 7.	A temporary poor contact. Check each connector for poor contact.

# DIAGNOSTICS FOR ENGINE STARTING FAILURE

ENGINE (DIAGNOSTICS)

Step	Check	Yes	No
<p><b>7</b></p> <p><b>CHECK INPUT VOLTAGE OF INHIBITOR SWITCH.</b>                      1) Turn the ignition switch to OFF.                      2) Disconnect the connector from inhibitor switch.                      3) Connect the connector to ignition switch.                      4) Measure the input voltage between inhibitor switch connector terminal and engine ground while turning ignition switch to ST.</p> <p><b>Connector &amp; terminal</b>  <b>(B12) No. 12 (+) — Engine ground (-):</b>                      Is the measured value more than specified value?</p>	10 V	Go to step 8.	Repair open or ground short circuit in harness between inhibitor switch and ignition switch.  NOTE: Check security system (if equipped).
<p><b>8</b></p> <p><b>CHECK INHIBITOR SWITCH.</b>                      1) Place the selector lever in the “P” or “N” position.                      2) Measure the resistance between inhibitor switch terminals.</p> <p><b>Connector &amp; terminal</b>  <b>(T3) No. 11 — No. 12:</b>                      Is the measured value less than specified value?</p>	1 Ω	Repair open or ground short circuit in harness between inhibitor switch and starter motor.	Replace the inhibitor switch.<Ref. to AT-48, Inhibitor Switch.>

# DIAGNOSTICS FOR ENGINE STARTING FAILURE

ENGINE (DIAGNOSTICS)

## C: CONTROL MODULE POWER SUPPLY AND GROUND LINE

### CAUTION:

After repair or replacement of faulty parts, conduct CLEAR MEMORY MODE <Ref. to EN(SOHC)-47, Clear Memory Mode.> and INSPECTION MODE. <Ref. to EN(SOHC)-40, Inspection Mode.>

### • WIRING DIAGRAM:

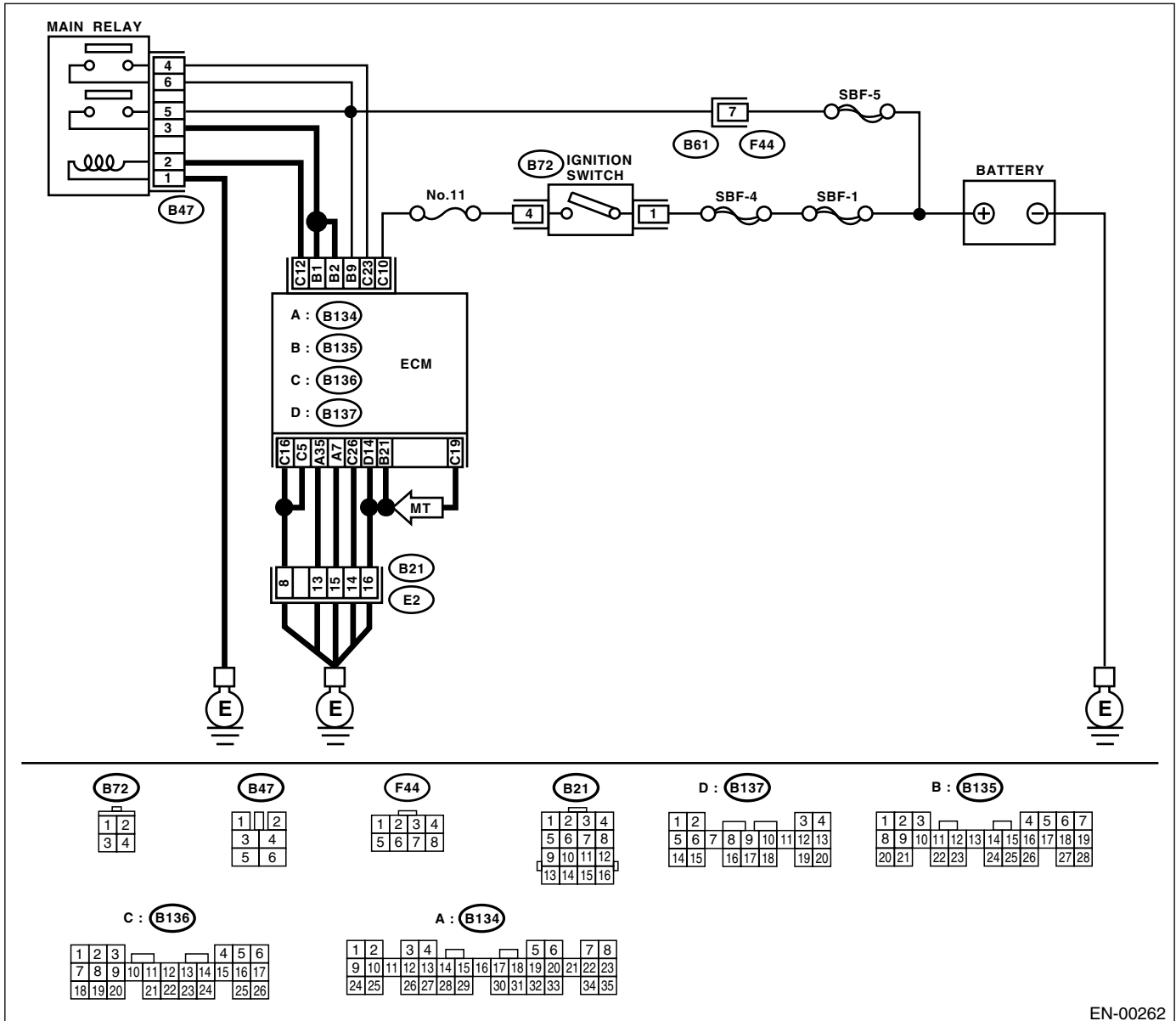

EN-00262



# DIAGNOSTICS FOR ENGINE STARTING FAILURE

ENGINE (DIAGNOSTICS)

Step	Check	Yes	No
<p><b>1 CHECK MAIN RELAY.</b>                      1) Turn the ignition switch to OFF.                      2) Remove the main relay.                      3) Connect the battery to main relay terminals No. 1 and No. 2.                      4) Measure the resistance between main relay terminals.</p> <p><b>Terminals</b>  <b>No. 3 — No. 5:</b>  <b>No. 4 — No. 6:</b></p> <p>Is the measured value less than specified value?</p>	10 Ω	Go to step 2.	Replace the main relay.
<p><b>2 CHECK GROUND CIRCUIT OF ECM.</b>                      1) Disconnect the connector from ECM.                      2) Measure the resistance of harness between ECM and chassis ground.</p> <p><b>Connector &amp; terminal</b>  <b>(B134) No. 7 — Chassis ground:</b>  <b>(B134) No. 35 — Chassis ground:</b>  <b>(B135) No. 21 — Chassis ground:</b>  <b>(B136) No. 5 — Chassis ground:</b>  <b>(B136) No. 16 — Chassis ground: (MT vehicles)</b>  <b>(B136) No. 19 — Chassis ground:</b>  <b>(B136) No. 26 — Chassis ground:</b>  <b>(B137) No. 14 — Chassis ground:</b></p> <p>Is the measured value less than specified value?</p>	5 Ω	Go to step 3.	Repair open circuit in harness between ECM connector and engine grounding terminal.
<p><b>3 CHECK INPUT VOLTAGE OF ECM.</b>                      Measure the voltage between ECM connector and chassis ground.</p> <p><b>Connector &amp; terminal</b>  <b>(B135) No. 9 (+) — Chassis ground (-):</b></p> <p>Is the measured value more than specified value?</p>	10 V	Go to step 4.	Repair open or ground short circuit of power supply circuit.
<p><b>4 CHECK INPUT VOLTAGE OF ECM.</b>                      1) Turn the ignition switch to ON.                      2) Measure the voltage between ECM connector and chassis ground.</p> <p><b>Connector &amp; terminal</b>  <b>(B136) No. 10 (+) — Chassis ground (-):</b></p> <p>Is the measured value more than specified value?</p>	10 V	Go to step 5.	Repair open or ground short circuit of power supply circuit.
<p><b>5 CHECK HARNESS BETWEEN ECM AND MAIN RELAY CONNECTOR.</b>                      1) Turn the ignition switch to OFF.                      2) Measure the resistance between ECM and chassis ground.</p> <p><b>Connector &amp; terminal</b>  <b>(B136) No. 12 — Chassis ground:</b></p> <p>Is the measured value more than specified value?</p>	1 MΩ	Go to step 6.	Repair ground short circuit in harness between ECM connector and main relay connector, then replace the ECM.

# DIAGNOSTICS FOR ENGINE STARTING FAILURE

## ENGINE (DIAGNOSTICS)

Step	Check	Yes	No
<b>6 CHECK OUTPUT VOLTAGE FROM ECM.</b> 1)Connect the connector to ECM. 2)Turn the ignition switch to ON. 3)Measure the voltage between ECM connector and chassis ground. <b>Connector &amp; terminal</b> <b>(B136) No. 12 (+) — Chassis ground (-):</b> Is the measured value more than specified value?	10 V	Go to step 7.	Replace the ECM.
<b>7 CHECK INPUT VOLTAGE OF MAIN RELAY.</b> Check the voltage between main relay connector and chassis ground. <b>Connector &amp; terminal</b> <b>(B47) No. 2 (+) — Chassis ground (-):</b> Is the measured value more than specified value?	10 V	Go to step 8.	Repair open circuit in harness between ECM connector and main relay connector.
<b>8 CHECK GROUND CIRCUIT OF MAIN RELAY.</b> 1)Turn the ignition switch to OFF. 2)Measure the resistance between main relay connector and chassis ground. <b>Connector &amp; terminal</b> <b>(B47) No. 1 — Chassis ground:</b> Is the measured value less than specified value?	5 Ω	Go to step 9.	Repair open circuit between main relay and chassis ground.
<b>9 CHECK INPUT VOLTAGE OF MAIN RELAY.</b> Measure the voltage between main relay connector and chassis ground. <b>Connector &amp; terminal</b> <b>(B47) No. 5 (+) — Chassis ground (-):</b> <b>(B47) No. 6 (+) — Chassis ground (-):</b> Is the measured value more than specified value?	10 V	Go to step 10.	Repair open or ground short circuit in harness of power supply circuit.
<b>10 CHECK INPUT VOLTAGE OF ECM.</b> 1)Connect the main relay connector. 2)Turn the ignition switch to ON. 3)Measure the voltage between ECM connector and chassis ground. <b>Connector &amp; terminal</b> <b>(B135) No. 1 (+) — Chassis ground (-):</b> <b>(B135) No. 2 (+) — Chassis ground (-):</b> <b>(B136) No. 23 (+) — Chassis ground (-):</b> Is the measured value more than specified value?	10 V	Check ignition control system. <Ref. to EN(SOHC)-67, IGNITION CONTROL SYSTEM, Diagnostics for Engine Starting Failure.>	Repair open or ground short circuit in harness between ECM connector and main relay connector.

# DIAGNOSTICS FOR ENGINE STARTING FAILURE

ENGINE (DIAGNOSTICS)

## D: IGNITION CONTROL SYSTEM

### CAUTION:

After repair or replacement of faulty parts, conduct CLEAR MEMORY MODE <Ref. to EN(SOHC)-47, Clear Memory Mode.> and INSPECTION MODE <Ref. to EN(SOHC)-40, Inspection Mode.>.

### • WIRING DIAGRAM:

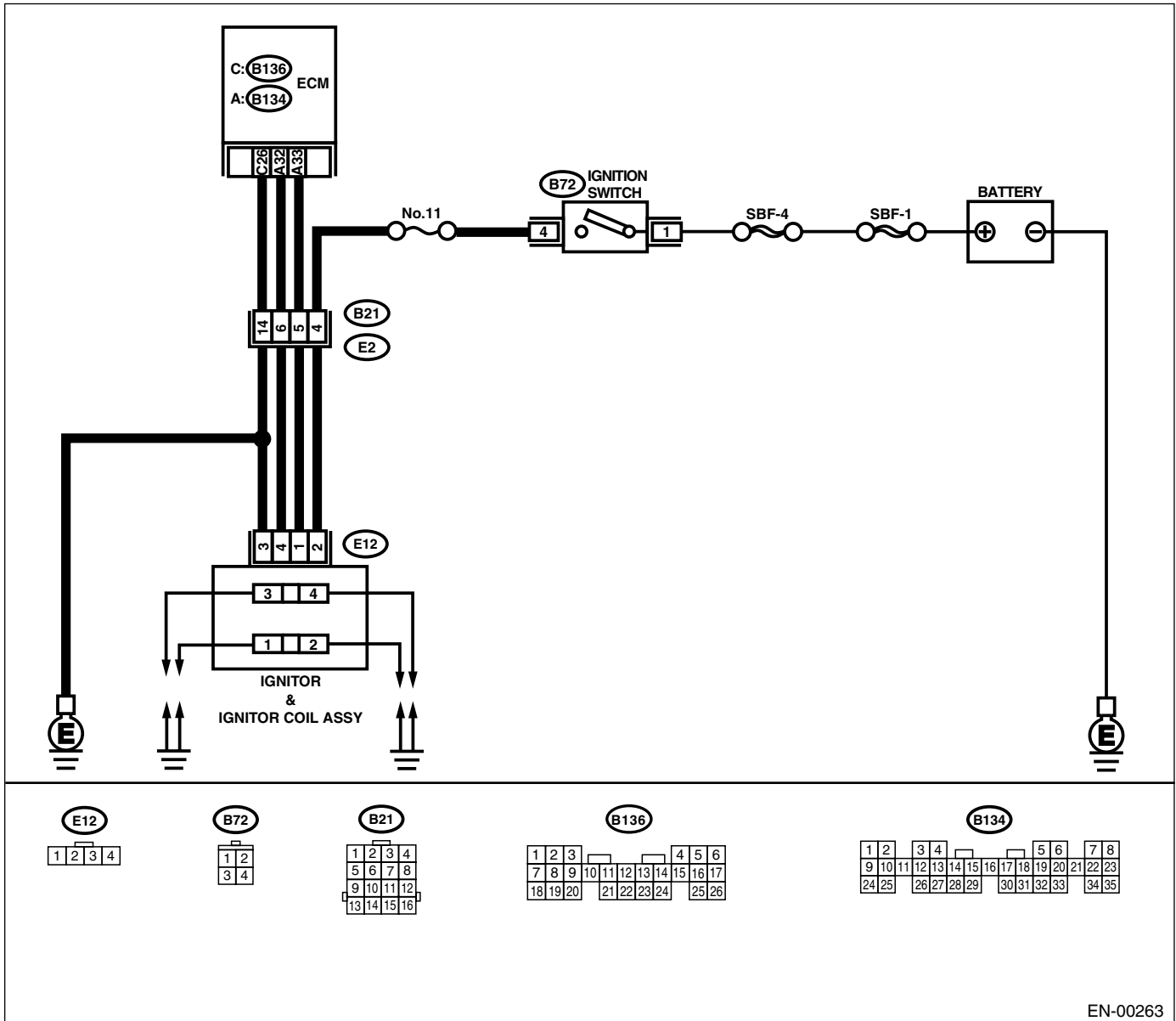

EN-00263

# DIAGNOSTICS FOR ENGINE STARTING FAILURE

## ENGINE (DIAGNOSTICS)

Step	Check	Yes	No
<p><b>1</b></p> <p><b>CHECK IGNITION SYSTEM FOR SPARKS.</b>                      1)Remove the plug cord cap from each spark plug.                      2)Install the new spark plug on plug cord cap.  <b>CAUTION:</b>  <b>Do not remove the spark plug from engine.</b>                      3)Contact the spark plug's thread portion on engine.                      4)While opening the throttle valve fully, crank the engine to check that spark occurs at each cylinder.                      Does spark occur at each cylinder?</p>	Spark occurs at each cylinder.	Check fuel pump system. <Ref. to EN(SOHC)-70, FUEL PUMP CIRCUIT, Diagnostics for Engine Starting Failure.>	Go to step 2.
<p><b>2</b></p> <p><b>CHECK POWER SUPPLY CIRCUIT FOR IGNITION COIL &amp; IGNITOR ASSEMBLY.</b>                      1)Turn the ignition switch to OFF.                      2)Disconnect the connector from ignition coil &amp; ignitor assembly.                      3)Turn the ignition switch to ON.                      4)Measure the power supply voltage between ignition coil &amp; ignitor assembly connector and engine ground.  <b>Connector &amp; terminal</b>  <b>(E12) No. 2 (+) — Engine ground (-):</b>                      Is the measured value more than specified value?</p>	10 V	Go to step 3.	Repair harness and connector. NOTE: In this case, repair the following: • Open circuit in harness between ignition coil & ignitor assembly, and ignition switch connector • Poor contact in coupling connectors
<p><b>3</b></p> <p><b>CHECK HARNESS OF IGNITION COIL &amp; IGNITOR ASSEMBLY GROUND CIRCUIT.</b>                      1)Turn the ignition switch to OFF.                      2)Measure the resistance between ignition coil &amp; ignitor assembly connector and engine ground.  <b>Connector &amp; terminal</b>  <b>(E12) No. 3 — Engine ground:</b>                      Is the measured value less than specified value?</p>	5 Ω	Go to step 4.	Repair harness and connector. NOTE: In this case, repair the following: • Open circuit in harness between ignition coil & ignitor assembly connector and engine grounding terminal
<p><b>4</b></p> <p><b>CHECK IGNITION COIL &amp; IGNITOR ASSEMBLY.</b>                      1)Remove the spark plug cords.                      2)Measure the resistance between spark plug cord contact portions to check secondary coil.  <b>Terminals</b>  <b>No. 1 — No. 2:</b>  <b>No. 3 — No. 4:</b>                      Is the measured value within specified value?</p>	10 — 15 kΩ	Go to step 5.	Replace the ignition coil & ignitor assembly. <Ref. to IG(SOHC)-8, Ignition Coil and Ignitor Assembly.>
<p><b>5</b></p> <p><b>CHECK INPUT SIGNAL FOR IGNITION COIL &amp; IGNITOR ASSEMBLY.</b>                      1)Connect the connector to ignition coil &amp; ignitor assembly.                      2)Check if voltage varies synchronously with engine speed when cranking, while monitoring voltage between ignition coil &amp; ignitor assembly connector and engine ground.  <b>Connector &amp; terminal</b>  <b>(E12) No. 1 (+) — Engine ground (-):</b>  <b>(E12) No. 4 (+) — Engine ground (-):</b>                      Is the measured value more than specified value?</p>	10 V	Go to step 6.	Replace the ignition coil & ignitor assembly. <Ref. to IG(SOHC)-8, Ignition Coil and Ignitor Assembly.>

# DIAGNOSTICS FOR ENGINE STARTING FAILURE

ENGINE (DIAGNOSTICS)

Step	Check	Yes	No
<p><b>6</b>     <b>CHECK HARNESS BETWEEN ECM AND IGNITION COIL &amp; IGNITOR ASSEMBLY CONNECTOR.</b>                      1) Turn the ignition switch to OFF.                      2) Disconnect the connector from ECM.                      3) Disconnect the connector from ignition coil &amp; ignitor assembly.                      4) Measure the resistance of harness between ECM and ignition coil &amp; ignitor assembly connector.</p> <p><b>Connector &amp; terminal</b>  <i>(B134) No. 33 — (E12) No. 1:</i>  <i>(B134) No. 32 — (E12) No. 4:</i></p> <p>Is the measured value less than specified value?</p>	1 Ω	Go to step 7.	Repair harness and connector. NOTE: In this case, repair the following: • Open circuit in harness between ECM and ignition coil & ignitor assembly connector • Poor contact in coupling connector
<p><b>7</b>     <b>CHECK HARNESS BETWEEN ECM AND IGNITION COIL &amp; IGNITOR ASSEMBLY CONNECTOR.</b>                      Measure the resistance of harness between ECM and engine ground.</p> <p><b>Connector &amp; terminal:</b>  <i>(B134) No. 33 — Engine ground:</i>  <i>(B134) No. 32 — Engine ground:</i></p> <p>Is the measured value more than specified value?</p>	1 MΩ	Go to step 8.	Repair ground short circuit in harness between ECM and ignition coil & ignitor assembly connector.
<p><b>8</b>     <b>CHECK POOR CONTACT.</b>                      Check poor contact in ECM connector.</p>	Is there poor contact in ECM connector?	Repair poor contact in ECM connector.	Check fuel pump circuit. <Ref. to EN(SOHC)-70, FUEL PUMP CIRCUIT, Diagnostics for Engine Starting Failure.>

# DIAGNOSTICS FOR ENGINE STARTING FAILURE

ENGINE (DIAGNOSTICS)

## E: FUEL PUMP CIRCUIT

### CAUTION:

After repair or replacement of faulty parts, conduct CLEAR MEMORY MODE <Ref. to EN(SOHC)-47, Clear Memory Mode.> and INSPECTION MODE <Ref. to EN(SOHC)-40, Inspection Mode.>.

### • WIRING DIAGRAM:

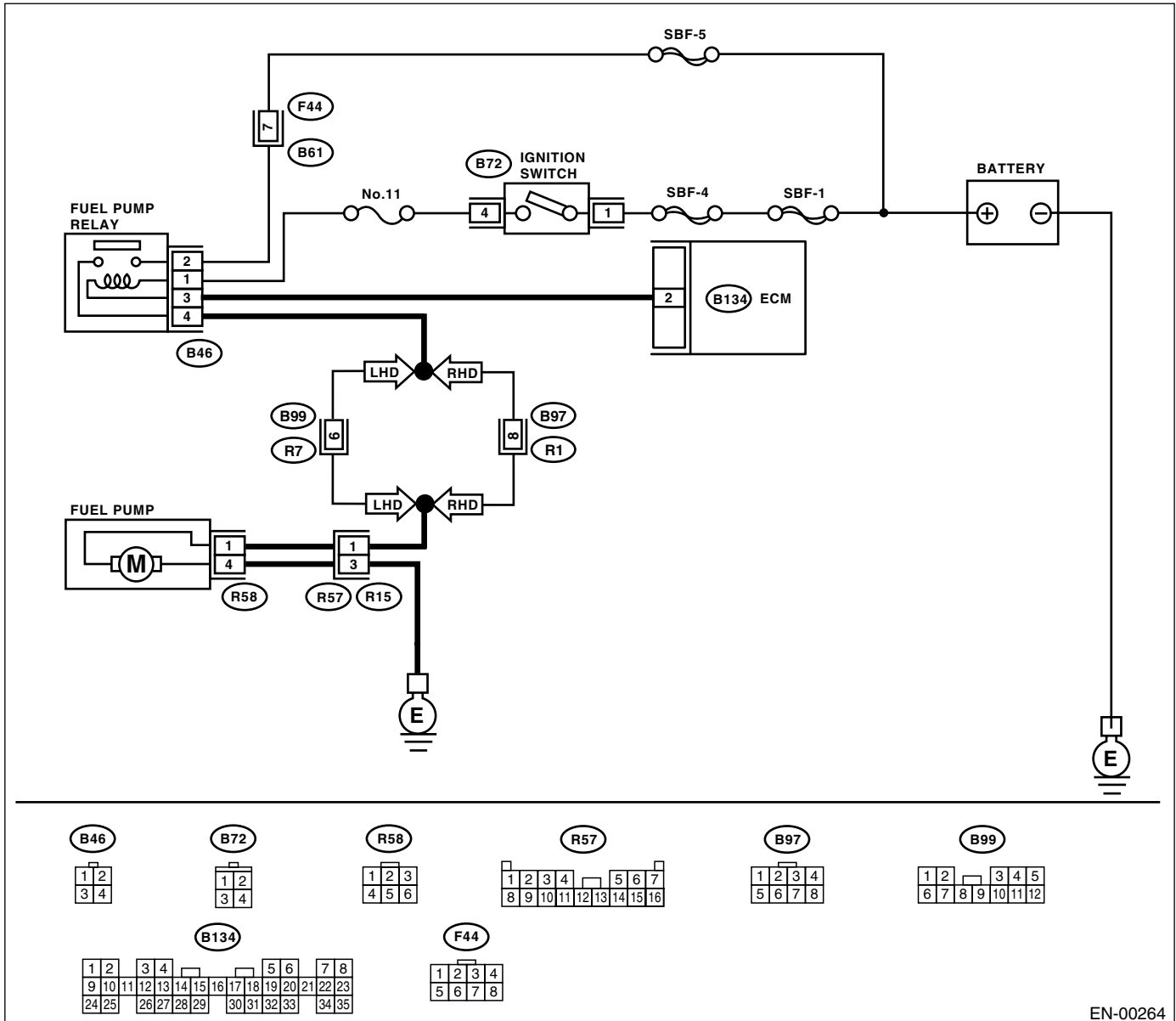

EN-00264

# DIAGNOSTICS FOR ENGINE STARTING FAILURE

ENGINE (DIAGNOSTICS)

Step	Check	Yes	No
<p><b>1 CHECK OPERATING SOUND OF FUEL PUMP.</b> Make sure that fuel pump is in operation for two seconds when turning the ignition switch to ON. Does the fuel pump produce operating sound? NOTE: Fuel pump operation can also be executed using Subaru Select Monitor (Function mode: FD01). For the procedure, refer to "Compulsory Valve Operation Check Mode". &lt;Ref. to EN(SOHC)-48, Compulsory Valve Operation Check Mode.&gt;</p>	Operating sound occurs.	Check fuel injector circuit. <Ref. to EN(SOHC)-73, FUEL INJECTOR CIRCUIT, Diagnostics for Engine Starting Failure.>	Go to step 2.
<p><b>2 CHECK GROUND CIRCUIT OF FUEL PUMP.</b> 1) Turn the ignition switch to OFF. 2) Remove the fuel pump access hole lid. 3) Disconnect the connector from fuel pump. 4) Measure the resistance of harness connector between fuel pump and chassis ground. <b>Connector &amp; terminal</b> <b>(R58) No. 4 — Chassis ground:</b> Is the measured value less than specified value?</p>	5 Ω	Go to step 3.	Repair harness and connector. NOTE: In this case, repair the following: • Open circuit in harness between fuel pump connector and chassis grounding terminal • Poor contact in coupling connector
<p><b>3 CHECK POWER SUPPLY TO FUEL PUMP.</b> 1) Turn the ignition switch to ON. 2) Measure the voltage of power supply circuit between fuel pump connector and chassis ground. <b>Connector &amp; terminal</b> <b>(R58) No. 1 (+) — Chassis ground (-):</b> Is the measured value more than specified value?</p>	10 V	Replace the fuel pump. <Ref. to FU(SOHC)-57, Fuel Pump.>	Go to step 4.
<p><b>4 CHECK HARNESS BETWEEN FUEL PUMP AND FUEL PUMP RELAY CONNECTOR.</b> 1) Turn the ignition switch to OFF. 2) Measure the resistance of harness connector between fuel pump and fuel pump relay. <b>Connector &amp; terminal</b> <b>(R58) No. 1 — (B46) No. 4:</b> Is the measured value less than specified value?</p>	1 Ω	Go to step 5.	Repair harness and connector. NOTE: In this case, repair the following: • Open circuit in harness between fuel pump connector and chassis grounding terminal • Poor contact in coupling connectors
<p><b>5 CHECK HARNESS BETWEEN FUEL PUMP AND FUEL PUMP RELAY CONNECTOR.</b> Measure the resistance of harness between fuel pump and fuel pump relay connector. <b>Connector &amp; terminal</b> <b>(R58) No. 1 — Chassis ground:</b> Is the measured value more than specified value?</p>	1 MΩ	Go to step 6.	Repair short circuit in harness between fuel pump and fuel pump relay connector.

# DIAGNOSTICS FOR ENGINE STARTING FAILURE

## ENGINE (DIAGNOSTICS)

Step	Check	Yes	No
<b>6 CHECK FUEL PUMP RELAY.</b> 1)Disconnect the connectors from fuel pump relay and main relay. 2)Remove the fuel pump relay and main relay with bracket. 3)Connect the battery to fuel pump relay connector terminals No. 1 and No. 3. 4)Measure the resistance between connector terminals of fuel pump relay. <b>Terminals</b> <b>No. 2 — No. 4:</b> Is the measured value less than specified value?	10 Ω	Go to step 7.	Replace the fuel pump relay. <Ref. to FU(SOHC)-48, Fuel Pump Relay.>
<b>7 CHECK HARNESS BETWEEN ECM AND FUEL PUMP RELAY CONNECTOR.</b> 1)Disconnect the connectors from ECM. 2)Measure the resistance of harness between ECM and fuel pump relay connector. <b>Connector &amp; terminal</b> <b>(B134) No. 2 — (B46) No. 3:</b> Is the measured value less than specified value?	1 Ω	Go to step 8.	Repair open circuit in harness between ECM and fuel pump relay connector.
<b>8 CHECK POOR CONTACT.</b> Check poor contact in ECM connector. Is there poor contact in ECM connector?	Poor contact occurs.	Repair poor contact in ECM connector.	Check fuel injector circuit. <Ref. to EN(SOHC)-73, FUEL INJECTOR CIRCUIT, Diagnostics for Engine Starting Failure.>



# DIAGNOSTICS FOR ENGINE STARTING FAILURE

ENGINE (DIAGNOSTICS)

## F: FUEL INJECTOR CIRCUIT

### CAUTION:

- Check or repair only faulty parts.
- After repair or replacement of faulty parts, conduct CLEAR MEMORY MODE <Ref. to EN(SOHC)-47, Clear Memory Mode.> and INSPECTION MODE. <Ref. to EN(SOHC)-40, Inspection Mode.>
- **WIRING DIAGRAM:**

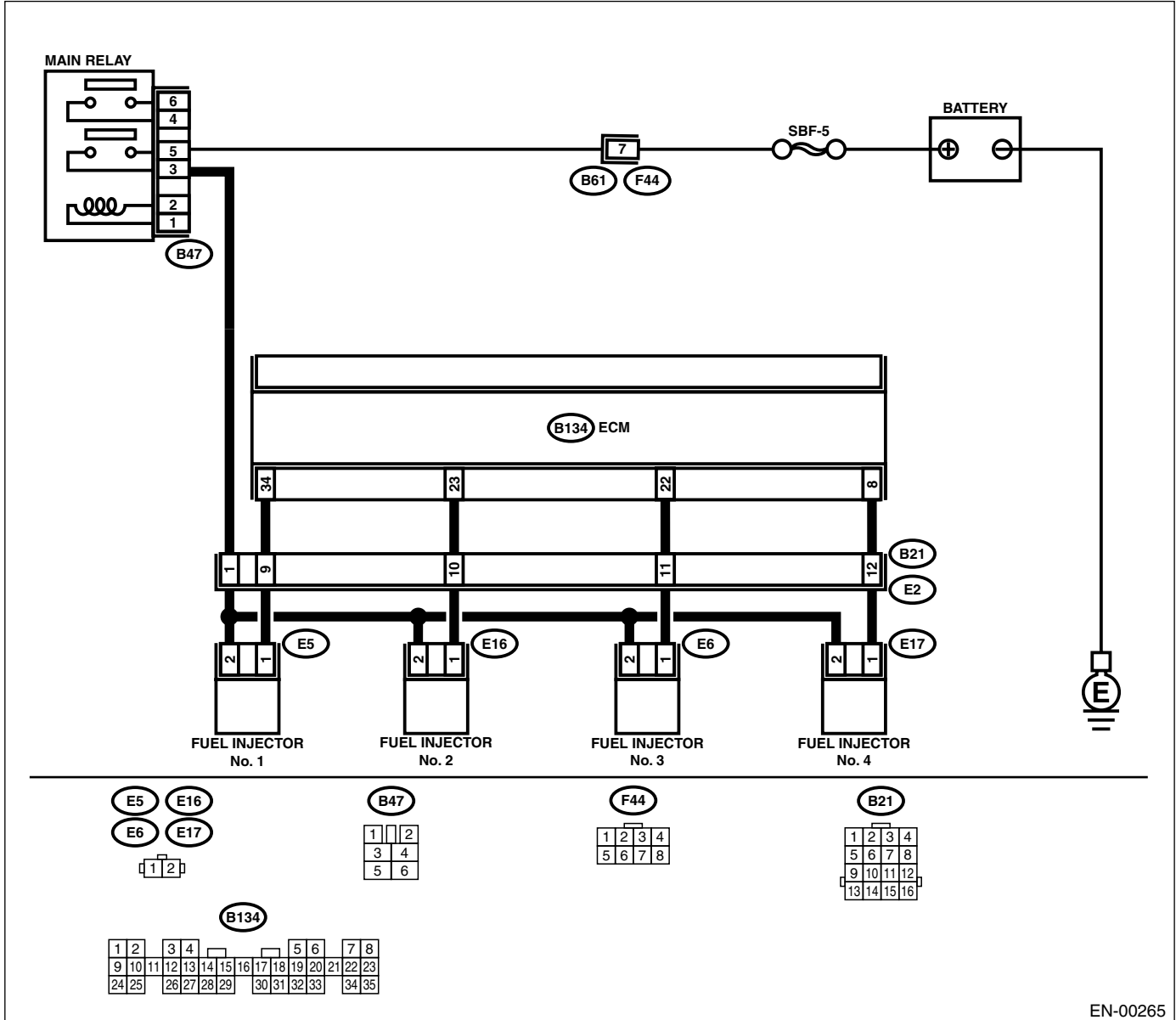

EN-00265

Step	Check	Yes	No
1	<p><b>CHECK OPERATION OF EACH FUEL INJECTOR.</b></p> <p>While cranking the engine, check that each fuel injector emits "operating" sound. Use a sound scope or attach a screwdriver to the injector for this check.</p> <p>Does the fuel injector emits operating sound?</p>	<p>Operating sound occurs.</p> <p>Check the fuel pressure. &lt;Ref. to ME(SOHC)-28, INSPECTION, Fuel Pressure.&gt;</p>	<p>Go to step 2.</p>

# DIAGNOSTICS FOR ENGINE STARTING FAILURE

## ENGINE (DIAGNOSTICS)

Step	Check	Yes	No
<p><b>2</b>      <b>CHECK POWER SUPPLY TO EACH FUEL INJECTOR.</b>                      1) Turn the ignition switch to OFF.                      2) Disconnect the connector from #1 cylinder fuel injector.                      3) Turn the ignition switch to ON.                      4) Measure the power supply voltage between the fuel injector terminal and engine ground.</p> <p><b>Connector &amp; terminal</b>  <b>#1 (E5) No. 2 (+) — Engine ground (-):</b>  <b>#2 (E16) No. 2 (+) — Engine ground (-):</b>  <b>#3 (E6) No. 2 (+) — Engine ground (-):</b>  <b>#4 (E17) No. 2 (+) — Engine ground (-):</b></p> <p>Is the measured value more than specified value?</p>	10 V	Go to step 3.	Repair harness and connector. NOTE: In this case, repair the following: <ul style="list-style-type: none"> <li>• Open circuit in harness between main relay and fuel injector connector</li> <li>• Poor contact in main relay connector</li> <li>• Poor contact in coupling connector (B22)</li> <li>• Poor contact in fuel injector connector</li> </ul>
<p><b>3</b>      <b>CHECK HARNESS BETWEEN ECM AND FUEL INJECTOR CONNECTOR.</b>                      1) Disconnect the connector from ECM.                      2) Measure the resistance of harness between ECM and fuel injector connector.</p> <p><b>Connector &amp; terminal</b>  <b>#1 (B134) No. 34 — (E5) No. 1:</b>  <b>#2 (B134) No. 23 — (E16) No. 1:</b>  <b>#3 (B134) No. 22 — (E6) No. 1:</b>  <b>#4 (B134) No. 8 — (E17) No. 1:</b></p> <p>Is the measured value less than specified value?</p>	1 Ω	Go to step 4.	Repair harness and connector. NOTE: In this case, repair the following: <ul style="list-style-type: none"> <li>• Open circuit in harness between ECM and fuel injector connector</li> <li>• Poor contact in coupling connector</li> </ul>
<p><b>4</b>      <b>CHECK HARNESS BETWEEN ECM AND FUEL INJECTOR CONNECTOR.</b>                      Measure the resistance of harness between ECM and fuel injector connector.</p> <p><b>Connector &amp; terminal</b>  <b>#1 (B134) No. 34 — Chassis ground:</b>  <b>#2 (B134) No. 23 — Chassis ground:</b>  <b>#3 (B134) No. 22 — Chassis ground:</b>  <b>#4 (B134) No. 8 — Chassis ground:</b></p> <p>Is the measured value more than specified value?</p>	1 MΩ	Go to step 5.	Repair ground short circuit in harness between ECM and fuel injector connector.
<p><b>5</b>      <b>CHECK EACH FUEL INJECTOR.</b>                      1) Turn the ignition switch to OFF.                      2) Measure the resistance between each fuel injector terminals.</p> <p><b>Terminals</b>  <b>No. 1 — No. 2:</b></p> <p>Is the measured value within specified value?</p>	5 — 20 Ω	Go to step 6.	Replace the faulty fuel injector.
<p><b>6</b>      <b>CHECK POOR CONTACT.</b>                      Check poor contact in ECM connector.                      Is there poor contact in ECM connector?</p>	Poor contact occurs.	Repair poor contact in ECM connector.	Inspection using "General Diagnostic Table". <Ref. to EN(SOHC)-261, INSPECTION, General Diagnostic Table.>

# LIST OF DIAGNOSTIC TROUBLE CODE (DTC)

ENGINE (DIAGNOSTICS)

## 18. List of Diagnostic Trouble Code (DTC)

### A: LIST

DTC No.	Item	Index
P0030	HO2S Heater Control Circuit (Bank 1 Sensor 1)	<Ref. to EN(SOHC)-81, DTC P0030 — HO2S HEATER CONTROL CIRCUIT (BANK 1/SENSOR 1) —, Diagnostic Procedure with Diagnostic Trouble Code (DTC).>
P0031	HO2S Heater Control Circuit Low (Bank 1 Sensor 1)	<Ref. to EN(SOHC)-83, DTC P0031 — HO2S HEATER CONTROL CIRCUIT LOW (BANK 1 SENSOR 1) —, Diagnostic Procedure with Diagnostic Trouble Code (DTC).>
P0032	HO2S Heater Control Circuit High (Bank 1 Sensor 1)	<Ref. to EN(SOHC)-86, DTC P0032 — HO2S HEATER CONTROL CIRCUIT HIGH (BANK 1 SENSOR 1) —, Diagnostic Procedure with Diagnostic Trouble Code (DTC).>
P0037	HO2S Heater Control Circuit Low (Bank 1 Sensor 2)	<Ref. to EN(SOHC)-88, DTC P0037 — HO2S HEATER CONTROL CIRCUIT LOW (BANK 1 SENSOR 2) —, Diagnostic Procedure with Diagnostic Trouble Code (DTC).>
P0038	HO2S Heater Control Circuit High (Bank 1 Sensor 2)	<Ref. to EN(SOHC)-91, DTC P0038 — HO2S HEATER CONTROL CIRCUIT HIGH (BANK 1 SENSOR 2) —, Diagnostic Procedure with Diagnostic Trouble Code (DTC).>
P0068	Manifold Absolute Pressure/Barometric Pressure Circuit Range/Performance	<Ref. to EN(SOHC)-93, DTC P0068 — MANIFOLD ABSOLUTE PRESSURE/BAROMETRIC PRESSURE CIRCUIT RANGE/PERFORMANCE —, Diagnostic Procedure with Diagnostic Trouble Code (DTC).>
P0107	Manifold Absolute Pressure/Barometric Pressure Circuit Low Input	<Ref. to EN(SOHC)-95, DTC P0107 — MANIFOLD ABSOLUTE PRESSURE/BAROMETRIC PRESSURE CIRCUIT LOW INPUT —, Diagnostic Procedure with Diagnostic Trouble Code (DTC).>
P0108	Manifold Absolute Pressure/Barometric Pressure Circuit High Input	<Ref. to EN(SOHC)-98, DTC P0108 — MANIFOLD ABSOLUTE PRESSURE/BAROMETRIC PRESSURE CIRCUIT HIGH INPUT —, Diagnostic Procedure with Diagnostic Trouble Code (DTC).>
P0111	Intake Air Temperature Circuit Range/Performance	<Ref. to EN(SOHC)-101, DTC P0111 — INTAKE AIR TEMPERATURE CIRCUIT RANGE/PERFORMANCE —, Diagnostic Procedure with Diagnostic Trouble Code (DTC).>
P0112	Intake Air Temperature Circuit Low Input	<Ref. to EN(SOHC)-103, DTC P0112 — INTAKE AIR TEMPERATURE CIRCUIT LOW INPUT —, Diagnostic Procedure with Diagnostic Trouble Code (DTC).>
P0113	Intake Air Temperature Circuit High Input	<Ref. to EN(SOHC)-105, DTC P0113 — INTAKE AIR TEMPERATURE CIRCUIT HIGH INPUT —, Diagnostic Procedure with Diagnostic Trouble Code (DTC).>
P0117	Engine Coolant Temperature Circuit Low Input	<Ref. to EN(SOHC)-108, DTC P0117 — ENGINE COOLANT TEMPERATURE CIRCUIT LOW INPUT —, Diagnostic Procedure with Diagnostic Trouble Code (DTC).>
P0118	Engine Coolant Temperature Circuit High Input	<Ref. to EN(SOHC)-110, DTC P0118 — ENGINE COOLANT TEMPERATURE CIRCUIT HIGH INPUT —, Diagnostic Procedure with Diagnostic Trouble Code (DTC).>
P0121	Throttle/Pedal Position Sensor/Switch "A" Circuit Range/Performance	<Ref. to EN(SOHC)-113, DTC P0121 — THROTTLE/PEDAL POSITION SENSOR/SWITCH "A" CIRCUIT RANGE/PERFORMANCE —, Diagnostic Procedure with Diagnostic Trouble Code (DTC).>
P0122	Throttle/Pedal Position Sensor/Switch "A" Circuit Low Input	<Ref. to EN(SOHC)-115, DTC P0122 — THROTTLE/PEDAL POSITION SENSOR/SWITCH "A" CIRCUIT LOW INPUT —, Diagnostic Procedure with Diagnostic Trouble Code (DTC).>
P0123	Throttle/Pedal Position Sensor/Switch "A" Circuit High Input	<Ref. to EN(SOHC)-118, DTC P0123 — THROTTLE/PEDAL POSITION SENSOR/SWITCH "A" CIRCUIT HIGH INPUT —, Diagnostic Procedure with Diagnostic Trouble Code (DTC).>
P0125	Insufficient Coolant Temperature for Closed Loop Fuel Control	<Ref. to EN(SOHC)-120, DTC P0125 — INSUFFICIENT COOLANT TEMPERATURE FOR CLOSED LOOP FUEL CONTROL —, Diagnostic Procedure with Diagnostic Trouble Code (DTC).>
P0129	Barometric Pressure Too Low	<Ref. to EN(SOHC)-122, DTC P0129 — BAROMETRIC PRESSURE TOO LOW —, Diagnostic Procedure with Diagnostic Trouble Code (DTC).>

## LIST OF DIAGNOSTIC TROUBLE CODE (DTC)

### ENGINE (DIAGNOSTICS)

DTC No.	Item	Index
P0130	O <sub>2</sub> Sensor Circuit (Bank 1 Sensor 1)	<Ref. to EN(SOHC)-123, DTC P0130 — O <sub>2</sub> SENSOR CIRCUIT (BANK 1 SENSOR 1) —, Diagnostic Procedure with Diagnostic Trouble Code (DTC).>
P0131	O <sub>2</sub> Sensor Circuit Low Voltage (Bank 1 Sensor 1)	<Ref. to EN(SOHC)-126, DTC P0131 — O <sub>2</sub> SENSOR CIRCUIT LOW VOLTAGE (BANK 1 SENSOR 1) —, Diagnostic Procedure with Diagnostic Trouble Code (DTC).>
P0132	O <sub>2</sub> Sensor Circuit High Voltage (Bank 1 Sensor 1)	<Ref. to EN(SOHC)-128, DTC P0132 — O <sub>2</sub> SENSOR CIRCUIT HIGH VOLTAGE (BANK 1 SENSOR 1) —, Diagnostic Procedure with Diagnostic Trouble Code (DTC).>
P0133	O <sub>2</sub> Sensor Circuit Slow Response (Bank 1 Sensor 1)	<Ref. to EN(SOHC)-130, DTC P0133 — O <sub>2</sub> SENSOR CIRCUIT SLOW RESPONSE (BANK 1 SENSOR 1) —, Diagnostic Procedure with Diagnostic Trouble Code (DTC).>
P0134	O <sub>2</sub> Sensor Circuit No Activity Detected (Bank 1 Sensor 1)	<Ref. to EN(SOHC)-132, DTC P0134 — O <sub>2</sub> SENSOR CIRCUIT NO ACTIVITY DETECTED (BANK 1 SENSOR 1) —, Diagnostic Procedure with Diagnostic Trouble Code (DTC).>
P0137	O <sub>2</sub> Sensor Circuit Low Voltage (Bank 1 Sensor 2)	<Ref. to EN(SOHC)-134, DTC P0137 — O <sub>2</sub> SENSOR CIRCUIT LOW VOLTAGE (BANK 1 SENSOR 2) —, Diagnostic Procedure with Diagnostic Trouble Code (DTC).>
P0138	O <sub>2</sub> Sensor Circuit High Voltage (Bank 1 Sensor 2)	<Ref. to EN(SOHC)-137, DTC P0138 — O <sub>2</sub> SENSOR CIRCUIT HIGH VOLTAGE (BANK 1 SENSOR 2) —, Diagnostic Procedure with Diagnostic Trouble Code (DTC).>
P0139	O <sub>2</sub> Sensor Circuit Slow Response (Bank 1 Sensor 2)	<Ref. to EN(SOHC)-140, DTC P0139 — O <sub>2</sub> SENSOR CIRCUIT SLOW RESPONSE (BANK 1 SENSOR 2) —, Diagnostic Procedure with Diagnostic Trouble Code (DTC).>
P0171	System too Lean (Bank 1)	<Ref. to EN(SOHC)-141, DTC P0171 — SYSTEM TOO LEAN (BANK 1) —, Diagnostic Procedure with Diagnostic Trouble Code (DTC).>
P0172	System too Rich (Bank 1)	<Ref. to EN(SOHC)-142, DTC P0172 — SYSTEM TOO RICH (BANK 1) —, Diagnostic Procedure with Diagnostic Trouble Code (DTC).>
P0301	Cylinder 1 Misfire Detected	<Ref. to EN(SOHC)-144, DTC P0301 — CYLINDER 1 MISFIRE DETECTED —, Diagnostic Procedure with Diagnostic Trouble Code (DTC).>
P0302	Cylinder 2 Misfire Detected	<Ref. to EN(SOHC)-144, DTC P0302 — CYLINDER 2 MISFIRE DETECTED —, Diagnostic Procedure with Diagnostic Trouble Code (DTC).>
P0303	Cylinder 3 Misfire Detected	<Ref. to EN(SOHC)-144, DTC P0303 — CYLINDER 3 MISFIRE DETECTED —, Diagnostic Procedure with Diagnostic Trouble Code (DTC).>
P0304	Cylinder 4 Misfire Detected	<Ref. to EN(SOHC)-145, DTC P0304 — CYLINDER 4 MISFIRE DETECTED —, Diagnostic Procedure with Diagnostic Trouble Code (DTC).>
P0327	Knock Sensor 1 Circuit Low Input (Bank 1 or Single Sensor)	<Ref. to EN(SOHC)-152, DTC P0327 — KNOCK SENSOR 1 CIRCUIT LOW INPUT (BANK 1 OR SINGLE SENSOR) —, Diagnostic Procedure with Diagnostic Trouble Code (DTC).>
P0328	Knock Sensor 1 Circuit High Input (Bank 1 or Single Sensor)	<Ref. to EN(SOHC)-154, DTC P0328 — KNOCK SENSOR 1 CIRCUIT HIGH INPUT (BANK 1 OR SINGLE SENSOR) —, Diagnostic Procedure with Diagnostic Trouble Code (DTC).>
P0335	Crankshaft Position Sensor "A" Circuit	<Ref. to EN(SOHC)-156, DTC P0335 — CRANKSHAFT POSITION SENSOR "A" CIRCUIT —, Diagnostic Procedure with Diagnostic Trouble Code (DTC).>
P0336	Crankshaft Position Sensor "A" Circuit Range/Performance	<Ref. to EN(SOHC)-158, DTC P0336 — CRANKSHAFT POSITION SENSOR "A" CIRCUIT RANGE/PERFORMANCE —, Diagnostic Procedure with Diagnostic Trouble Code (DTC).>
P0340	Camshaft Position Sensor "A" Circuit (Bank 1 or Single Sensor)	<Ref. to EN(SOHC)-160, DTC P0340 — CAMSHAFT POSITION SENSOR "A" CIRCUIT (BANK 1 OR SINGLE SENSOR) —, Diagnostic Procedure with Diagnostic Trouble Code (DTC).>
P0341	Camshaft Position Sensor "A" Circuit Range/Performance (Bank 1 or Single Sensor)	<Ref. to EN(SOHC)-162, DTC P0341 — CAMSHAFT POSITION SENSOR "A" CIRCUIT RANGE/PERFORMANCE (BANK 1 OR SINGLE SENSOR) —, Diagnostic Procedure with Diagnostic Trouble Code (DTC).>
P0400	Exhaust Gas Recirculation Flow	<Ref. to EN(SOHC)-165, DTC P0400 — EXHAUST GAS RECIRCULATION FLOW —, Diagnostic Procedure with Diagnostic Trouble Code (DTC).>

# LIST OF DIAGNOSTIC TROUBLE CODE (DTC)

ENGINE (DIAGNOSTICS)

DTC No.	Item	Index
P0420	Catalyst System Efficiency Below Threshold (Bank 1)	<Ref. to EN(SOHC)-168, DTC P0420 — CATALYST SYSTEM EFFICIENCY BELOW THRESHOLD (BANK 1) —, Diagnostic Procedure with Diagnostic Trouble Code (DTC).>
P0458	Evaporative Emission Control System Purge Control Valve Circuit Low	<Ref. to EN(SOHC)-170, DTC P0458 — EVAPORATIVE EMISSION CONTROL SYSTEM PURGE CONTROL VALVE CIRCUIT LOW —, Diagnostic Procedure with Diagnostic Trouble Code (DTC).>
P0459	Evaporative Emission Control System Purge Control Valve Circuit High	<Ref. to EN(SOHC)-173, DTC P0459 — EVAPORATIVE EMISSION CONTROL SYSTEM PURGE CONTROL VALVE CIRCUIT HIGH —, Diagnostic Procedure with Diagnostic Trouble Code (DTC).>
P0461	Fuel Level Sensor Circuit Range/Performance	<Ref. to EN(SOHC)-176, DTC P0461 — FUEL LEVEL SENSOR CIRCUIT RANGE/PERFORMANCE —, Diagnostic Procedure with Diagnostic Trouble Code (DTC).>
P0462	Fuel Level Sensor Circuit Low Input	<Ref. to EN(SOHC)-178, DTC P0462 — FUEL LEVEL SENSOR CIRCUIT LOW INPUT —, Diagnostic Procedure with Diagnostic Trouble Code (DTC).>
P0463	Fuel Level Sensor Circuit High Input	<Ref. to EN(SOHC)-181, DTC P0463 — FUEL LEVEL SENSOR CIRCUIT HIGH INPUT —, Diagnostic Procedure with Diagnostic Trouble Code (DTC).>
P0464	Fuel Level Sensor Circuit Intermittent	<Ref. to EN(SOHC)-184, DTC P0464 — FUEL LEVEL SENSOR CIRCUIT INTERMITTENT —, Diagnostic Procedure with Diagnostic Trouble Code (DTC).>
P0483	Cooling Fan Rationality Check	<Ref. to EN(SOHC)-186, DTC P0483 — COOLING FAN RATIONALITY CHECK —, Diagnostic Procedure with Diagnostic Trouble Code (DTC).>
P0502	Vehicle Speed Sensor Circuit Low Input	<Ref. to EN(SOHC)-189, DTC P0502 — VEHICLE SPEED SENSOR CIRCUIT LOW INPUT —, Diagnostic Procedure with Diagnostic Trouble Code (DTC).>
P0503	Vehicle Speed Sensor Circuit High Input	<Ref. to EN(SOHC)-190, DTC P0503 — VEHICLE SPEED SENSOR CIRCUIT HIGH INPUT —, Diagnostic Procedure with Diagnostic Trouble Code (DTC).>
P0506	Idle Control System RPM Lower Than Expected	<Ref. to EN(SOHC)-192, DTC P0506 — IDLE CONTROL SYSTEM RPM LOWER THAN EXPECTED —, Diagnostic Procedure with Diagnostic Trouble Code (DTC).>
P0507	Idle Control System RPM Higher Than Expected	<Ref. to EN(SOHC)-194, DTC P0507 — IDLE CONTROL SYSTEM RPM HIGHER THAN EXPECTED —, Diagnostic Procedure with Diagnostic Trouble Code (DTC).>
P0512	Starter Request Circuit	<Ref. to EN(SOHC)-196, DTC P0512 — STARTER REQUEST CIRCUIT —, Diagnostic Procedure with Diagnostic Trouble Code (DTC).>
P0513	Incorrect Immobilizer Key	<Ref. to IM-20, DTC P0153 INCORRECT IMMOBILIZER KEY (USE OF UNREGISTERED KEY), Diagnostics Chart with Diagnostic Trouble Code (DTC).>
P0519	Idle Control System Circuit Performance	<Ref. to EN(SOHC)-199, DTC P0519 — IDLE CONTROL SYSTEM CIRCUIT PERFORMANCE —, Diagnostic Procedure with Diagnostic Trouble Code (DTC).>
P0565	Cruise Control On Signal	<Ref. to EN(SOHC)-201, DTC P0565 — CRUISE CONTROL ON SIGNAL —, Diagnostic Procedure with Diagnostic Trouble Code (DTC).>
P0604	Internal Control Module Random Access Memory (RAM) Error	<Ref. to EN(SOHC)-203, DTC P0604 — INTERNAL CONTROL MODULE RANDOM ACCESS MEMORY (RAM) ERROR —, Diagnostic Procedure with Diagnostic Trouble Code (DTC).>
P0691	Cooling Fan 1 Control Circuit Low	<Ref. to EN(SOHC)-205, DTC P0691 — COOLING FAN 1 CONTROL CIRCUIT LOW —, Diagnostic Procedure with Diagnostic Trouble Code (DTC).>
P0692	Cooling Fan 1 Control Circuit High	<Ref. to EN(SOHC)-209, DTC P0692 — COOLING FAN 1 CONTROL CIRCUIT HIGH —, Diagnostic Procedure with Diagnostic Trouble Code (DTC).>
P0703	Torque Converter/Brake Switch "B" Circuit	<Ref. to EN(SOHC)-212, DTC P0703 — TORQUE CONVERTER/BRAKE SWITCH "B" CIRCUIT —, Diagnostic Procedure with Diagnostic Trouble Code (DTC).>

## LIST OF DIAGNOSTIC TROUBLE CODE (DTC)

### ENGINE (DIAGNOSTICS)

DTC No.	Item	Index
P0705	Transmission Range Sensor Circuit (PRNDL Input)	<Ref. to AT-114, CHECK INHIBITOR SWITCH., Diagnostic Procedure for No-diagnostic Trouble Code (DTC).>
P0710	Transmission Fluid Temperature Sensor Circuit	<Ref. to AT-43, DTC 27 ATF TEMPERATURE SENSOR, Diagnostic Procedure with Diagnostic Trouble Code (DTC).>
P0716	Input/Turbine Speed Sensor Circuit Range/Performance	<Ref. to AT-59, DTC 36 TORQUE CONVERTER TURBINE SPEED SENSOR, Diagnostic Procedure with Diagnostic Trouble Code (DTC).>
P0720	Output Speed Sensor Circuit	<Ref. to AT-54, DTC 33 FRONT VEHICLE SPEED SENSOR, Diagnostic Procedure with Diagnostic Trouble Code (DTC).>
P0726	Engine Speed Input Circuit Range/Performance	<Ref. to AT-38, DTC 11 ENGINE SPEED SIGNAL, Diagnostic Procedure with Diagnostic Trouble Code (DTC).>
P0731	Gear 1 Incorrect Ratio	<Ref. to EN(SOHC)-214, DTC P0731 — GEAR 1 INCORRECT RATIO —, Diagnostic Procedure with Diagnostic Trouble Code (DTC).>
P0732	Gear 2 Incorrect Ratio	<Ref. to EN(SOHC)-214, DTC P0732 — GEAR 2 INCORRECT RATIO —, Diagnostic Procedure with Diagnostic Trouble Code (DTC).>
P0733	Gear 3 Incorrect Ratio	<Ref. to EN(SOHC)-214, DTC P0733 — GEAR 3 INCORRECT RATIO —, Diagnostic Procedure with Diagnostic Trouble Code (DTC).>
P0734	Gear 4 Incorrect Ratio	<Ref. to EN(SOHC)-215, DTC P0734 — GEAR 4 INCORRECT RATIO —, Diagnostic Procedure with Diagnostic Trouble Code (DTC).>
P0741	Torque Converter Clutch Circuit Performance or Stuck Off	<Ref. to EN(SOHC)-216, DTC P0741 — TORQUE CONVERTER CLUTCH CIRCUIT PERFORMANCE OR STUCK OFF —, Diagnostic Procedure with Diagnostic Trouble Code (DTC).>
P0743	Torque Converter Clutch Circuit Electrical	<Ref. to AT-87, DTC 77 LOCK-UP DUTY SOLENOID, Diagnostic Procedure with Diagnostic Trouble Code (DTC).>
P0748	Pressure Control Solenoid "A" Electrical	<Ref. to AT-79, DTC 75 LINE PRESSURE DUTY SOLENOID, Diagnostic Procedure with Diagnostic Trouble Code (DTC).>
P0753	Shift Solenoid "A" Electrical	<Ref. to AT-66, DTC 71 SHIFT SOLENOID 1, Diagnostic Procedure with Diagnostic Trouble Code (DTC).>
P0758	Shift Solenoid "B" Electrical	<Ref. to AT-69, DTC 72 SHIFT SOLENOID 2, Diagnostic Procedure with Diagnostic Trouble Code (DTC).>
P0771	Shift Solenoid "E" Performance or Stuck Off	<Ref. to AT-72, DTC 73 LOW CLUTCH TIMING SOLENOID, Diagnostic Procedure with Diagnostic Trouble Code (DTC).>
P0778	Pressure Control Solenoid "B" Electrical	<Ref. to AT-83, DTC 76 2-4 BRAKE DUTY SOLENOID, Diagnostic Procedure with Diagnostic Trouble Code (DTC).>
P0785	Shift/Timing Solenoid	<Ref. to AT-75, DTC 74 2-4 BRAKE TIMING SOLENOID, Diagnostic Procedure with Diagnostic Trouble Code (DTC).>
P0851	Neutral Switch Input Circuit Low	<Ref. to EN(SOHC)-218, DTC P0851 — NEUTRAL SWITCH INPUT CIRCUIT LOW (AT VEHICLES) —, Diagnostic Procedure with Diagnostic Trouble Code (DTC).><Ref. to EN(SOHC)-220, DTC P0851 — NEUTRAL SWITCH INPUT CIRCUIT LOW (MT VEHICLES) —, Diagnostic Procedure with Diagnostic Trouble Code (DTC).>
P0852	Neutral Switch Input Circuit High	<Ref. to EN(SOHC)-223, DTC P0852 — NEUTRAL SWITCH INPUT CIRCUIT HIGH —, Diagnostic Procedure with Diagnostic Trouble Code (DTC).>
P0864	TCM Communication Circuit Range/Performance	<Ref. to EN(SOHC)-226, DTC P0864 — TCM COMMUNICATION CIRCUIT RANGE/PERFORMANCE —, Diagnostic Procedure with Diagnostic Trouble Code (DTC).>
P0865	TCM Communication Circuit Low	<Ref. to EN(SOHC)-228, DTC P0865 — TCM COMMUNICATION CIRCUIT LOW —, Diagnostic Procedure with Diagnostic Trouble Code (DTC).>
P0866	TCM Communication Circuit High	<Ref. to EN(SOHC)-230, DTC P0866 — TCM COMMUNICATION CIRCUIT HIGH —, Diagnostic Procedure with Diagnostic Trouble Code (DTC).>
P1110	Atmospheric Pressure Sensor Circuit Malfunction (Low Input)	<Ref. to EN(SOHC)-232, DTC P1110 — ATMOSPHERIC PRESSURE SENSOR CIRCUIT MALFUNCTION (LOW INPUT) —, Diagnostic Procedure with Diagnostic Trouble Code (DTC).>
P1111	Atmospheric Pressure Sensor Circuit Malfunction (High Input)	<Ref. to EN(SOHC)-233, DTC P1111 — ATMOSPHERIC PRESSURE SENSOR CIRCUIT MALFUNCTION (HIGH INPUT) —, Diagnostic Procedure with Diagnostic Trouble Code (DTC).>

# LIST OF DIAGNOSTIC TROUBLE CODE (DTC)

ENGINE (DIAGNOSTICS)

DTC No.	Item	Index
P1134	A/F Sensor Micro-computer Problem	<Ref. to EN(SOHC)-234, DTC P1134 — A/F SENSOR MICRO-COMPUTER PROBLEM —, Diagnostic Procedure with Diagnostic Trouble Code (DTC).>
P1137	O <sub>2</sub> Sensor Circuit (Bank1 Sensor1)	<Ref. to EN(SOHC)-235, DTC P1137 — O <sub>2</sub> SENSOR CIRCUIT (BANK1 SENSOR1) —, Diagnostic Procedure with Diagnostic Trouble Code (DTC).>
P1492	EGR Solenoid Valve Signal #1 Circuit Malfunction (Low Input)	<Ref. to EN(SOHC)-238, DTC P1492 — EGR SOLENOID VALVE SIGNAL #1 CIRCUIT MALFUNCTION (LOW INPUT) —, Diagnostic Procedure with Diagnostic Trouble Code (DTC).>
P1493	EGR Solenoid Valve Signal #1 Circuit Malfunction (High Input)	<Ref. to EN(SOHC)-238, DTC P1493 — EGR SOLENOID VALVE SIGNAL #1 CIRCUIT MALFUNCTION (HIGH INPUT) —, Diagnostic Procedure with Diagnostic Trouble Code (DTC).>
P1494	EGR Solenoid Valve Signal #2 Circuit Malfunction (Low Input)	<Ref. to EN(SOHC)-238, DTC P1494 — EGR SOLENOID VALVE SIGNAL #2 CIRCUIT MALFUNCTION (LOW INPUT) —, Diagnostic Procedure with Diagnostic Trouble Code (DTC).>
P1495	EGR Solenoid Valve Signal #2 Circuit Malfunction (High Input)	<Ref. to EN(SOHC)-238, DTC P1495 — EGR SOLENOID VALVE SIGNAL #2 CIRCUIT MALFUNCTION (HIGH INPUT) —, Diagnostic Procedure with Diagnostic Trouble Code (DTC).>
P1496	EGR Solenoid Valve Signal #3 Circuit Malfunction (Low Input)	<Ref. to EN(SOHC)-238, DTC P1496 — EGR SOLENOID VALVE SIGNAL #3 CIRCUIT MALFUNCTION (LOW INPUT) —, Diagnostic Procedure with Diagnostic Trouble Code (DTC).>
P1497	EGR Solenoid Valve Signal #3 Circuit Malfunction (High Input)	<Ref. to EN(SOHC)-238, DTC P1497 — EGR SOLENOID VALVE SIGNAL #3 CIRCUIT MALFUNCTION (HIGH INPUT) —, Diagnostic Procedure with Diagnostic Trouble Code (DTC).>
P1498	EGR Solenoid Valve Signal #4 Circuit Malfunction (Low Input)	<Ref. to EN(SOHC)-239, DTC P1498 — EGR SOLENOID VALVE SIGNAL #4 CIRCUIT MALFUNCTION (LOW INPUT) —, Diagnostic Procedure with Diagnostic Trouble Code (DTC).>
P1499	EGR Solenoid Valve Signal #4 Circuit Malfunction (High Input)	<Ref. to EN(SOHC)-241, DTC P1499 — EGR SOLENOID VALVE SIGNAL #4 CIRCUIT MALFUNCTION (HIGH INPUT) —, Diagnostic Procedure with Diagnostic Trouble Code (DTC).>
P1510	ISC Solenoid Valve Signal #1 Circuit Malfunction (Low Input)	<Ref. to EN(SOHC)-243, DTC P1510 — IDLE AIR CONTROL SOLENOID VALVE SIGNAL 1 CIRCUIT LOW INPUT —, Diagnostic Procedure with Diagnostic Trouble Code (DTC).>
P1511	ISC Solenoid Valve Signal #1 Circuit Malfunction (High Input)	<Ref. to EN(SOHC)-243, DTC P1511 — IDLE AIR CONTROL SOLENOID VALVE SIGNAL 1 CIRCUIT HIGH INPUT —, Diagnostic Procedure with Diagnostic Trouble Code (DTC).>
P1512	ISC Solenoid Valve Signal #2 Circuit Malfunction (Low Input)	<Ref. to EN(SOHC)-243, DTC P1512 — IDLE AIR CONTROL SOLENOID VALVE SIGNAL 2 CIRCUIT LOW INPUT —, Diagnostic Procedure with Diagnostic Trouble Code (DTC).>
P1513	ISC Solenoid Valve Signal #2 Circuit Malfunction (High Input)	<Ref. to EN(SOHC)-243, DTC P1513 — IDLE AIR CONTROL SOLENOID VALVE SIGNAL 2 CIRCUIT HIGH INPUT —, Diagnostic Procedure with Diagnostic Trouble Code (DTC).>
P1514	ISC Solenoid Valve Signal #3 Circuit Malfunction (Low Input)	<Ref. to EN(SOHC)-243, DTC P1514 — IDLE AIR CONTROL SOLENOID VALVE SIGNAL 3 CIRCUIT LOW INPUT —, Diagnostic Procedure with Diagnostic Trouble Code (DTC).>
P1515	ISC Solenoid Valve Signal #3 Circuit Malfunction (High Input)	<Ref. to EN(SOHC)-243, DTC P1515 — IDLE AIR CONTROL SOLENOID VALVE SIGNAL 3 CIRCUIT HIGH INPUT —, Diagnostic Procedure with Diagnostic Trouble Code (DTC).>
P1516	ISC Solenoid Valve Signal #4 Circuit Malfunction (Low Input)	<Ref. to EN(SOHC)-244, DTC P1516 — IDLE AIR CONTROL SOLENOID VALVE SIGNAL 4 CIRCUIT LOW INPUT —, Diagnostic Procedure with Diagnostic Trouble Code (DTC).>
P1517	ISC Solenoid Valve Signal #4 Circuit Malfunction (High Input)	<Ref. to EN(SOHC)-246, DTC P1517 — IDLE AIR CONTROL SOLENOID VALVE SIGNAL 4 CIRCUIT HIGH INPUT —, Diagnostic Procedure with Diagnostic Trouble Code (DTC).>
P1518	Starter Switch Circuit Low input	<Ref. to EN(SOHC)-248, DTC P1518 — STARTER SWITCH CIRCUIT LOW INPUT —, Diagnostic Procedure with Diagnostic Trouble Code (DTC).>

## LIST OF DIAGNOSTIC TROUBLE CODE (DTC)

### ENGINE (DIAGNOSTICS)

DTC No.	Item	Index
P1560	Back-up Voltage Circuit Malfunction	<Ref. to EN(SOHC)-251, DTC P1560 — BACK-UP VOLTAGE CIRCUIT MALFUNCTION —, Diagnostic Procedure with Diagnostic Trouble Code (DTC).>
P1570	Antenna	<Ref. to IM-21, DTC P1570 ANTENNA, Diagnostics Chart with Diagnostic Trouble Code (DTC).>
P1571	Reference Code Incompatibility	<Ref. to IM-15, DTC P1571 REFERENCE CODE INCOMPATIBILITY, Diagnostics Chart with Diagnostic Trouble Code (DTC).>
P1572	IMM Circuit Failure (Except antenna circuit)	<Ref. to IM-16, DTC P1572 IMM CIRCUIT FAILURE (EXCEPT ANTENNA CIRCUIT), Diagnostics Chart with Diagnostic Trouble Code (DTC).>
P1574	Key Communication Failure	<Ref. to IM-19, DTC P1574 KEY COMMUNICATION FAILURE, Diagnostics Chart with Diagnostic Trouble Code (DTC).>
P1576	EGI Control Module EEPROM	<Ref. to IM-20, DTC P1576 EGI CONTROL MODULE EEPROM, Diagnostics Chart with Diagnostic Trouble Code (DTC).>
P1577	IMM Control Module EEPROM	<Ref. to IM-20, DTC P1577 IMM CONTROL MODULE EEPROM, Diagnostics Chart with Diagnostic Trouble Code (DTC).>
P1698	Engine Torque Control Cut Signal Circuit Malfunction (Low Input)	<Ref. to EN(SOHC)-253, DTC P1698 — ENGINE TORQUE CONTROL CUT SIGNAL CIRCUIT MALFUNCTION (LOW INPUT) —, Diagnostic Procedure with Diagnostic Trouble Code (DTC).>
P1699	Engine Torque Control Cut Signal Circuit Malfunction (High Input)	<Ref. to EN(SOHC)-255, DTC P1699 — ENGINE TORQUE CONTROL CUT SIGNAL CIRCUIT MALFUNCTION (HIGH INPUT) —, Diagnostic Procedure with Diagnostic Trouble Code (DTC).>
P1700	Throttle Position Sensor Circuit Malfunction for AT	<Ref. to AT-47, DTC 31 THROTTLE POSITION SENSOR, Diagnostic Procedure with Diagnostic Trouble Code (DTC).>
P1711	Engine Torque Control Signal #1 Circuit Malfunction	<Ref. to EN(SOHC)-257, DTC P1711 — ENGINE TORQUE CONTROL SIGNAL #1 CIRCUIT MALFUNCTION —, Diagnostic Procedure with Diagnostic Trouble Code (DTC).>
P1712	Engine Torque Control Signal #2 Circuit Malfunction	<Ref. to EN(SOHC)-259, DTC P1712 — ENGINE TORQUE CONTROL SIGNAL #2 CIRCUIT MALFUNCTION —, Diagnostic Procedure with Diagnostic Trouble Code (DTC).>