

ENGINE 2 SECTION

This service manual has been prepared to provide SUBARU service personnel with the necessary information and data for the correct maintenance and repair of SUBARU vehicles. This manual includes the procedures for maintenance, disassembling, reassembling, inspection and adjustment of components and diagnostics for guidance of experienced mechanics. Please peruse and utilize this manual fully to ensure complete repair work for satisfying our customers by keeping their vehicle in optimum condition. When replacement of parts during repair work is needed, be sure to use SUBARU genuine parts.

All information, illustration and specifications contained in this manual are based on the latest product information available at the time of publication approval.

FUEL INJECTION (FUEL SYSTEMS)	FU(TURBO)
EMISSION CONTROL (AUX. EMISSION CONTROL DEVICES)	EC(TURBO)
INTAKE (INDUCTION)	IN(TURBO)
MECHANICAL	ME(TURBO)
EXHAUST	EX(TURBO)
COOLING	CO(TURBO)
LUBRICATION	LU(TURBO)
SPEED CONTROL SYSTEMS	SP(TURBO)
IGNITION	IG(TURBO)
STARTING/CHARGING SYSTEMS	SC(TURBO)
ENGINE(DIAGNOSTICS)	EN(TURBO)

FUEL INJECTION (FUEL SYSTEMS)

FU(TURBO)

	Page
1. General Description	2
2. Throttle Body	13
3. Intake Manifold	14
4. Engine Coolant Temperature Sensor.....	28
5. Crankshaft Position Sensor.....	29
6. Camshaft Position Sensor.....	30
7. Knock Sensor	31
8. Throttle Position Sensor	32
9. Mass Air Flow and Intake Air Temperature Sensor	33
10. Pressure Sensor	34
11. Idle Air Control Solenoid Valve	35
12. Fuel Injector	36
13. Tumble Generator Valve Assembly	40
14. Tumble Generator Valve Actuator.....	41
15. Wastegate Control Solenoid Valve	42
16. Front Oxygen (A/F) Sensor	43
17. Rear Oxygen Sensor.....	45
18. Exhaust Temperature Sensor	47
19. Engine Control Module.....	48
20. Main Relay	49
21. Fuel Pump Relay.....	50
22. Fuel Pump Controller	51
23. Fuel	52
24. Fuel Tank	53
25. Fuel Filler Pipe	55
26. Fuel Pump.....	59
27. Fuel Level Sensor	61
28. Fuel Sub Level Sensor	62
29. Fuel Filter	64
30. Fuel Cut Valve.....	65
31. Fuel Damper Valve	66
32. Fuel Delivery, Return and Evaporation Lines.....	67
33. Fuel System Trouble in General	70

GENERAL DESCRIPTION

FUEL INJECTION (FUEL SYSTEMS)

1. General Description

A: SPECIFICATIONS

Fuel tank	Capacity	60 ℓ (15.9 US gal, 13.2 Imp gal)
	Location	Under rear seat
Fuel pump	Type	Impeller
	Shutoff discharge pressure	450 — 677 kPa (4.59 — 6.9 kg/cm ² , 65.27 — 98.2 psi)
	Discharge flow	More than 130 ℓ (34.3 US gal, 28.6 Imp gal)/h [12 V at 300 kPa (3.06 kg/cm ² , 43.5 psi)]
Fuel filter		Cartridge type

GENERAL DESCRIPTION

FUEL INJECTION (FUEL SYSTEMS)

B: COMPONENT

1. INTAKE MANIFOLD

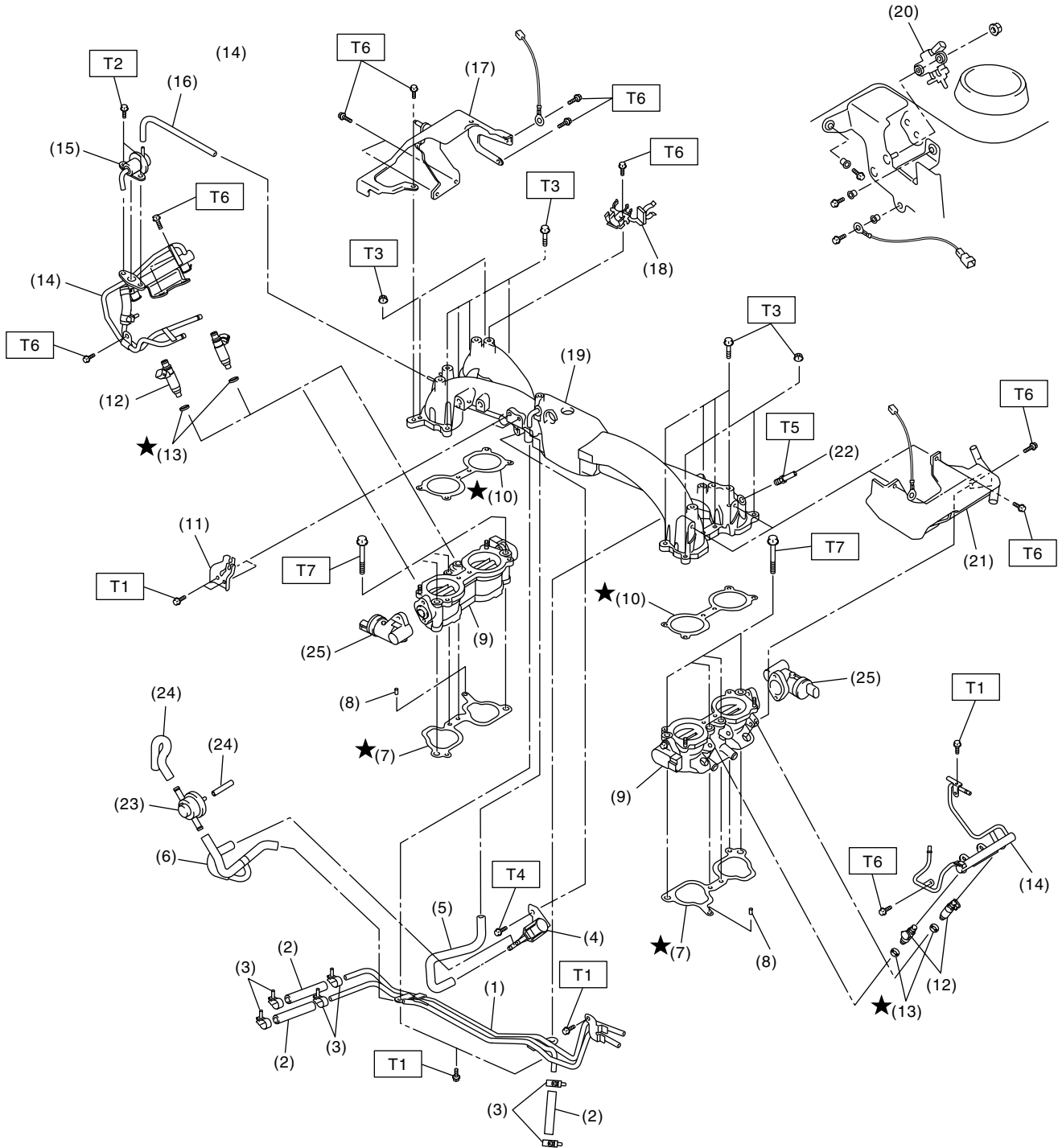

FU-00362

GENERAL DESCRIPTION

FUEL INJECTION (FUEL SYSTEMS)

(1) Fuel pipe ASSY	(13) Insulator	(24) Purge hose
(2) Fuel hose	(14) Fuel injector pipe	(25) Tumble generator valve actuator
(3) Clip	(15) Pressure regulator	
(4) Purge control solenoid valve	(16) Pressure regulator hose	<hr/>
(5) Vacuum hose	(17) Fuel pipe protector RH	Tightening torque: N·m (kgf·m, ft·lb)
(6) Vacuum control hose	(18) Blow-by hose stay	T1: 5.0 (0.5, 3.6)
(7) Intake manifold gasket	(19) Intake manifold	T2: 6.4 (0.65, 4.7)
(8) Guide pin	(20) Wastegate control solenoid valve ASSY	T3: 8.25 (0.84, 6.1)
(9) Tumble generator valve ASSY	(21) Fuel pipe protector LH	T4: 16 (1.6, 11.8)
(10) Gasket	(22) Nipple	T5: 17 (1.7, 12.5)
(11) Accelerator cable bracket (MT vehicles only)	(23) Purge valve	T6: 19 (1.9, 14.0)
(12) Fuel injector		<hr/>
		T7: 25 (2.5, 18.4)

GENERAL DESCRIPTION

FUEL INJECTION (FUEL SYSTEMS)

2. AIR INTAKE SYSTEM

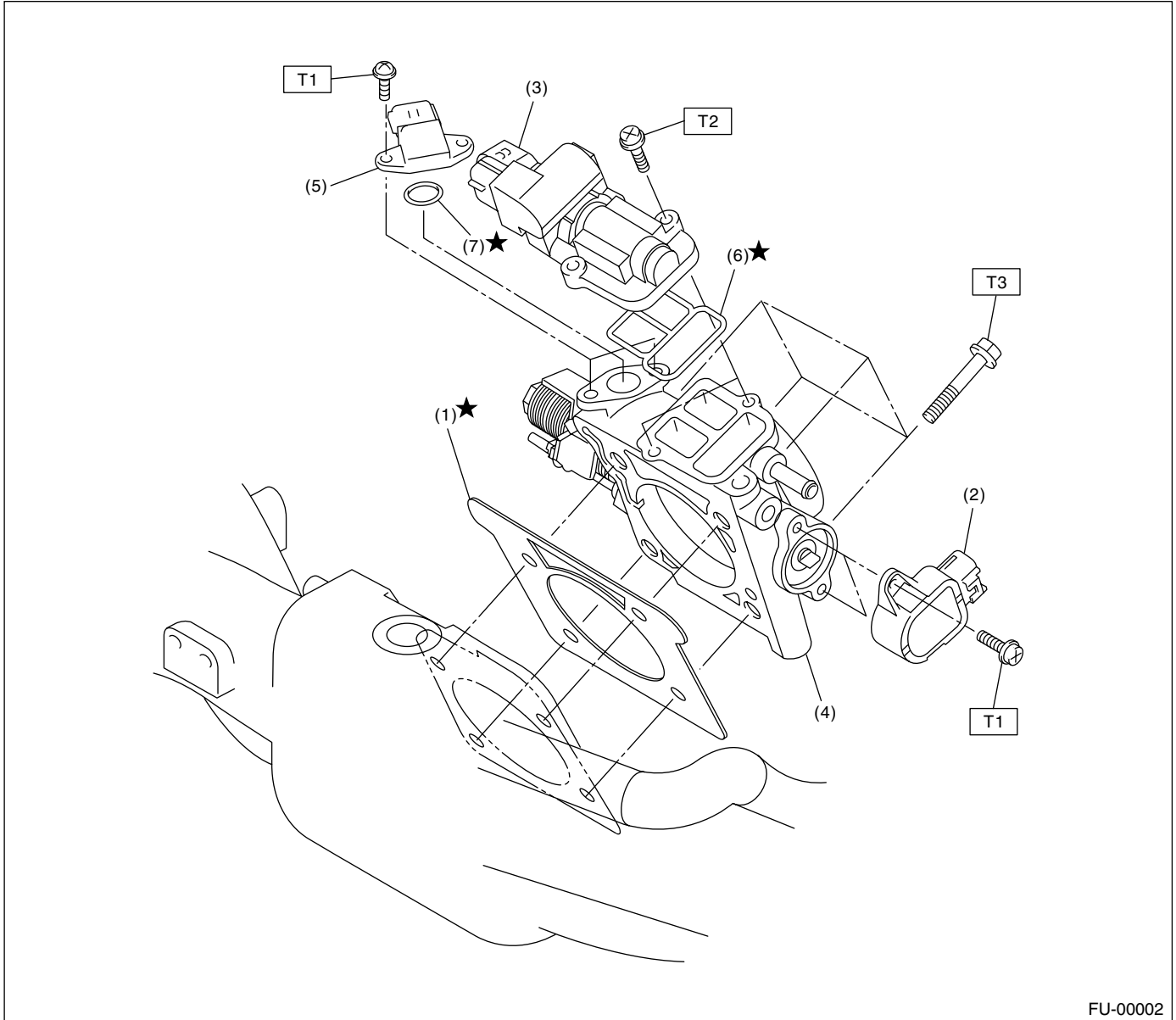

- (1) Gasket
- (2) Throttle position sensor
- (3) Idle air control solenoid valve
- (4) Throttle body

- (5) Pressure sensor
- (6) Gasket
- (7) O-ring

Tightening torque: N·m (kgf·m, ft·lb)

T1: 1.6 (0.16, 1.2)

T2: 2.8 (0.29, 2.1)

T3: 22 (2.2, 16.2)

GENERAL DESCRIPTION

FUEL INJECTION (FUEL SYSTEMS)

3. CRANKSHAFT POSITION, CAMSHAFT POSITION AND KNOCK SENSORS

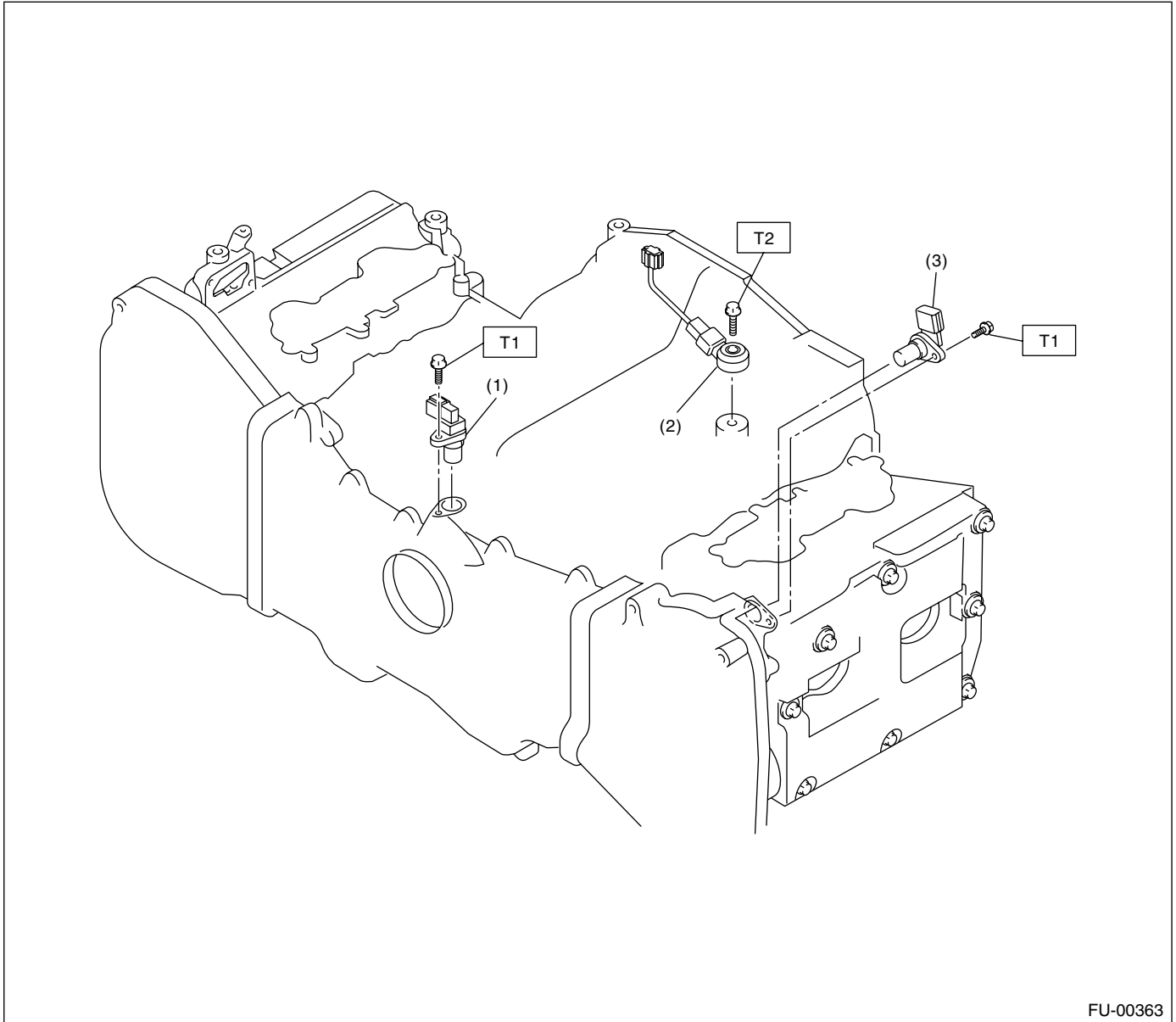

- (1) Crankshaft position sensor
- (2) Knock sensor

- (3) Camshaft position sensor

Tightening torque: N·m (kgf·m, ft·lb)

T1: 6.4 (0.65, 4.7)

T2: 24 (2.4, 17.4)

GENERAL DESCRIPTION

FUEL INJECTION (FUEL SYSTEMS)

4. FUEL TANK

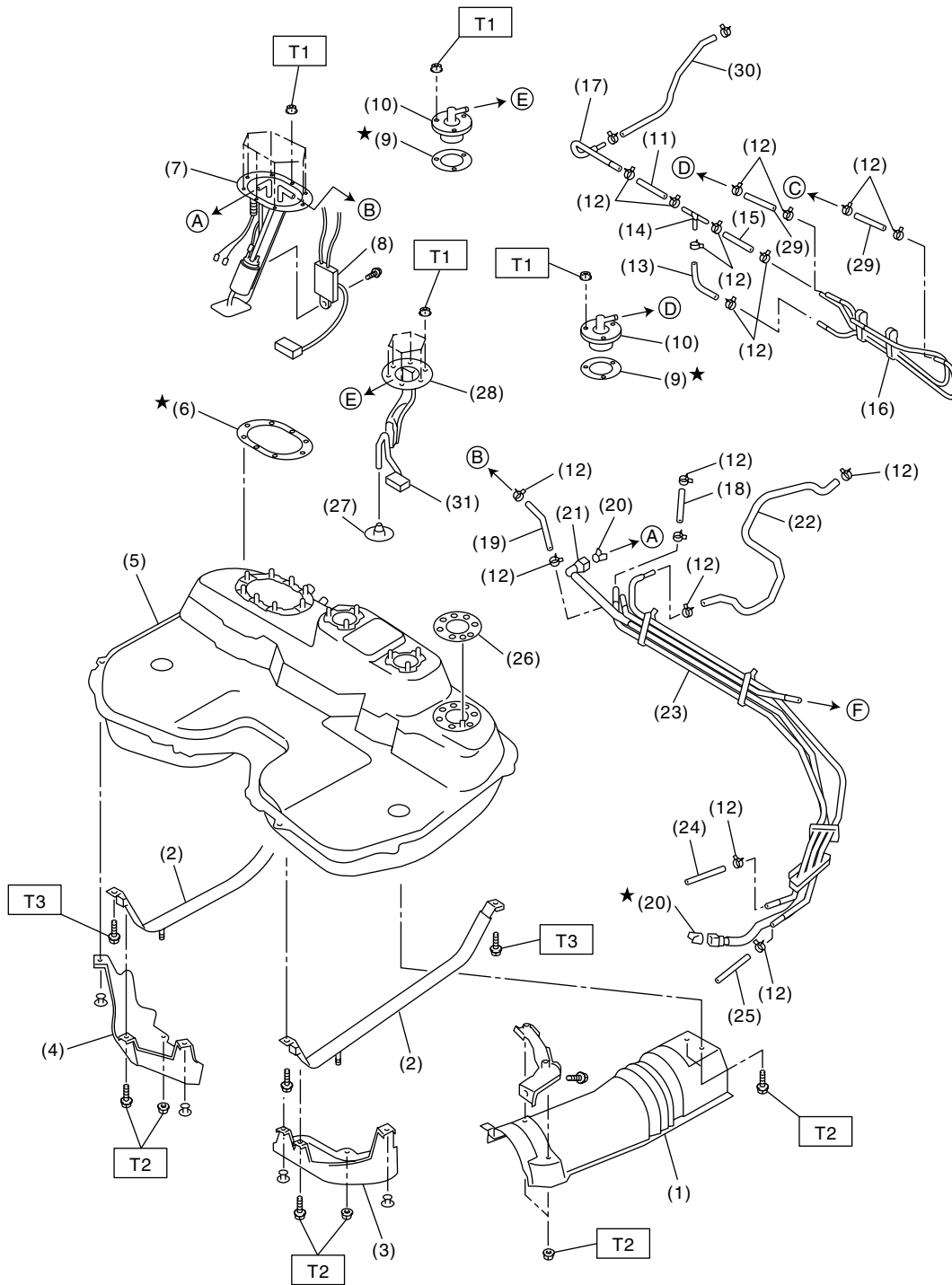

FU-00422

GENERAL DESCRIPTION

FUEL INJECTION (FUEL SYSTEMS)

- | | | |
|---------------------------|----------------------------|-----------------------------------|
| (1) Heat shield cover | (13) Evaporation hose B | (25) Fuel return hose B |
| (2) Fuel tank band | (14) Joint pipe | (26) Fuel sub level sensor gasket |
| (3) Protector LH | (15) Evaporation hose C | (27) Jet pump filter |
| (4) Protector RH | (16) Evaporation pipe ASSY | (28) Fuel sub level sensor unit |
| (5) Fuel tank | (17) Evaporation pipe | (29) Evaporation hose G |
| (6) Fuel pump gasket | (18) Evaporation hose D | (30) Evaporation hose H |
| (7) Fuel pump ASSY | (19) Fuel return hose A | |
| (8) Fuel meter unit | (20) Retainer | |
| (9) Fuel cut valve gasket | (21) Quick connector | |
| (10) Fuel cut valve | (22) Evaporation hose E | |
| (11) Evaporation hose A | (23) Fuel pipe ASSY | |
| (12) Clip | (24) Evaporation hose F | |

Tightening torque: N·m (kgf·m, ft·lb)

T1: 4.4 (0.45, 3.3)

T2: 7.4 (0.75, 5.4)

T3: 33 (3.4, 24.3)

GENERAL DESCRIPTION

FUEL INJECTION (FUEL SYSTEMS)

5. FUEL LINE

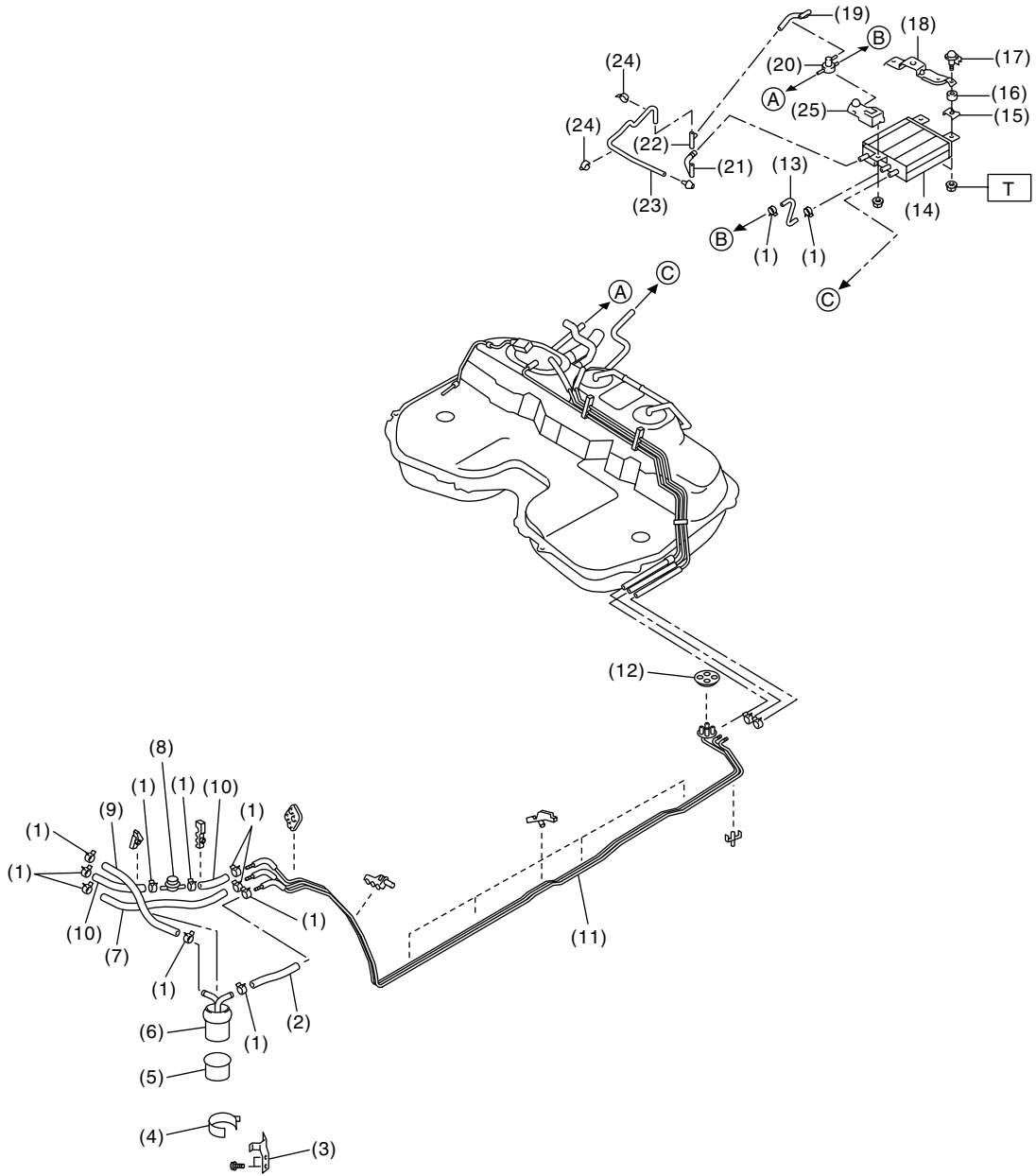

FU-00516

GENERAL DESCRIPTION

FUEL INJECTION (FUEL SYSTEMS)

- | | | |
|--------------------------|--------------------------------|---------------------------------|
| (1) Clip | (11) Fuel pipe ASSY | (21) Two-way valve drain hose A |
| (2) Fuel delivery hose A | (12) Grommet | (22) Connector |
| (3) Fuel filter bracket | (13) Canister hose A | (23) Two-way valve drain hose B |
| (4) Fuel filter holder | (14) Canister | (24) Clamp |
| (5) Fuel filter cup | (15) Canister bracket plate | (25) Front canister bracket |
| (6) Fuel filter | (16) Cushion | |
| (7) Evaporation hose | (17) Canister bracket spacer | |
| (8) Fuel damper | (18) Rear canister bracket | |
| (9) Fuel delivery hose B | (19) Two-way valve return hose | |
| (10) Fuel return hose | (20) Two-way valve | |

Tightening torque: N·m (kgf·m, ft·lb)

T: 23 (2.3, 17.0)

GENERAL DESCRIPTION

FUEL INJECTION (FUEL SYSTEMS)

6. FUEL FILLER PIPE

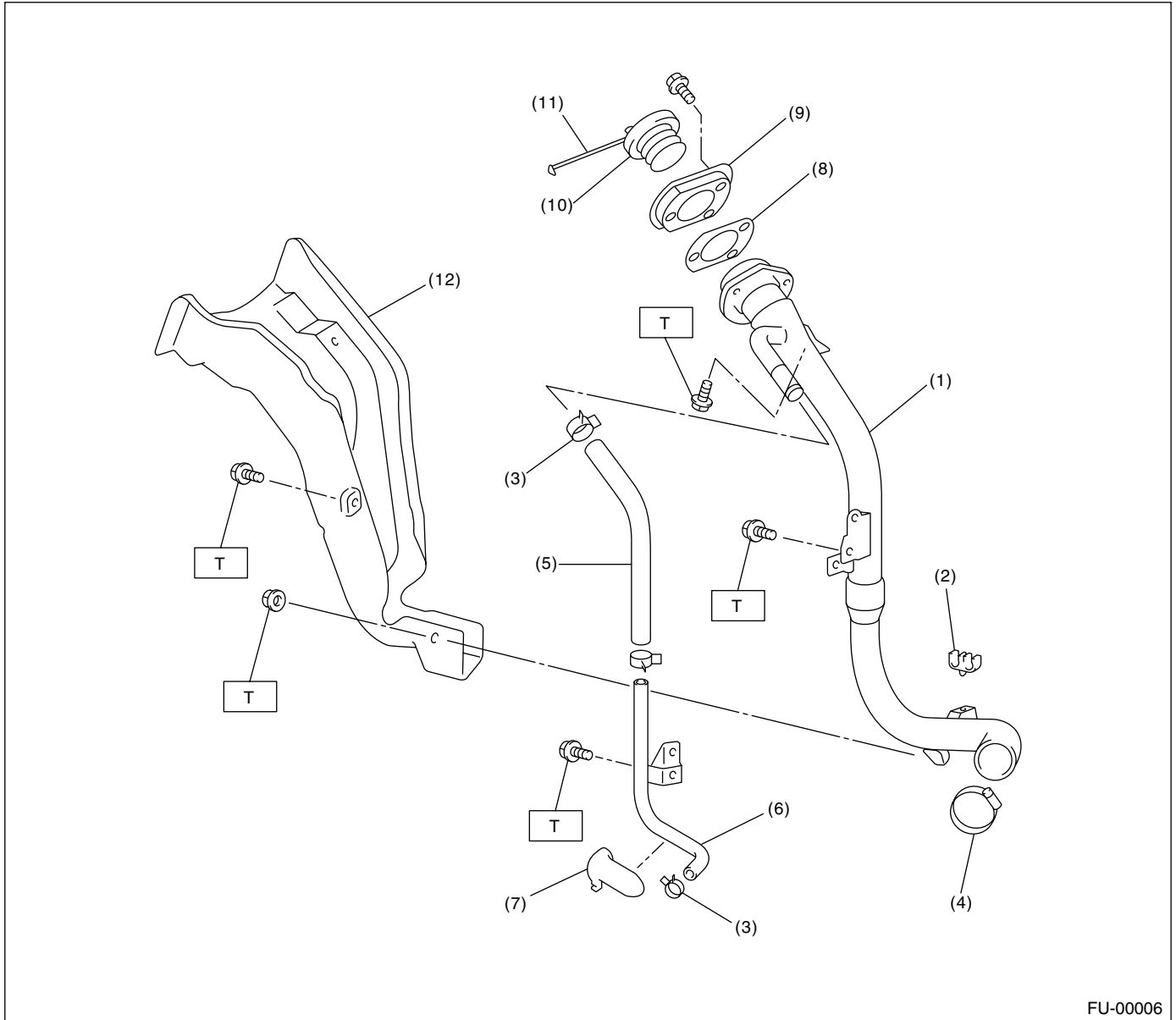

FU-00006

- | | | |
|-----------------------------|--------------------------|----------------------------|
| (1) Fuel filler pipe ASSY | (6) Air vent pipe | (11) Filler cap tether |
| (2) Evaporation hose holder | (7) Air vent pipe holder | (12) Filler pipe protector |
| (3) Clip | (8) Filler pipe packing | |
| (4) Clamp | (9) Filler ring | |
| (5) Air vent hose | (10) Filler cap | |

Tightening torque: N·m (kgf·m, ft·lb)
T: 7.5 (0.76, 5.5)

GENERAL DESCRIPTION



FUEL INJECTION (FUEL SYSTEMS)

C: CAUTION

- Wear working clothing, including a cap, protective goggles, and protective shoes during operation.
- Remove contamination including dirt and corrosion before removal, installation or disassembly.
- Keep the disassembled parts in order and protect them from dust or dirt.
- Before removal, installation or disassembly, be sure to clarify the failure. Avoid unnecessary removal, installation, disassembly, and replacement.

- Be careful not to burn your hands, because each part on the vehicle is hot after running.
- Be sure to tighten fasteners including bolts and nuts to the specified torque.
- Place shop jacks or safety stands at the specified points.
- Before disconnecting electrical connectors of sensors or units, be sure to disconnect the ground cable from battery.
- Place "NO FIRE" signs near the working area.
- Be careful not to spill fuel on the floor.

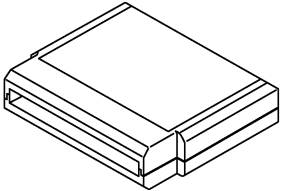
D: PREPARATION TOOL

ILLUSTRATION	TOOL NUMBER	DESCRIPTION	REMARKS
 <p style="text-align: center;">ST24082AA210</p>	<p style="text-align: center;">24082AA210 (Newly adopted tool)</p>	<p style="text-align: center;">CARTRIDGE</p>	<p style="text-align: center;">Troubleshooting for electrical system.</p>
 <p style="text-align: center;">ST22771AA030</p>	<p style="text-align: center;">22771AA030</p>	<p style="text-align: center;">SELECT MONI-TOR KIT</p>	<p style="text-align: center;">Troubleshooting for electrical systems.</p>

2. Throttle Body

A: REMOVAL

1) Disconnect the ground cable from battery.

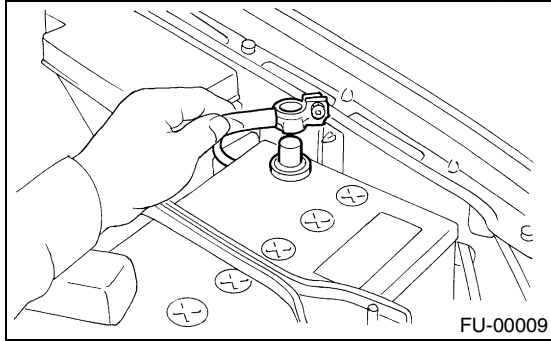

2) Remove the intercooler. <Ref. to IN(TURBO)-10, REMOVAL, Intercooler.>

3) Disconnect the connector from the throttle position sensor (A) and idle air control solenoid valve (B) and pressure sensor (C).

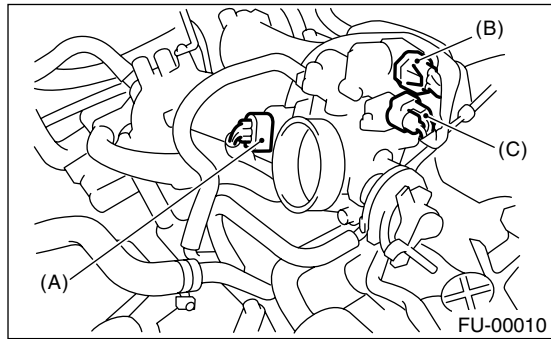

4) Disconnect the accelerator cable.

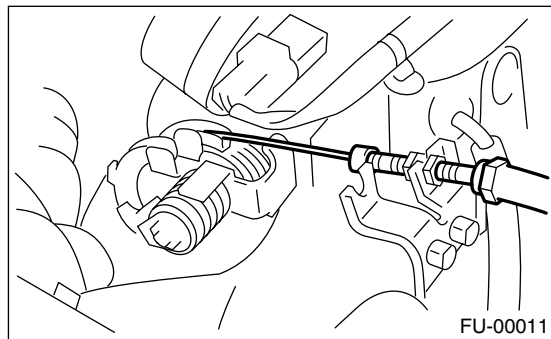

5) Disconnect the engine coolant hoses from throttle body.

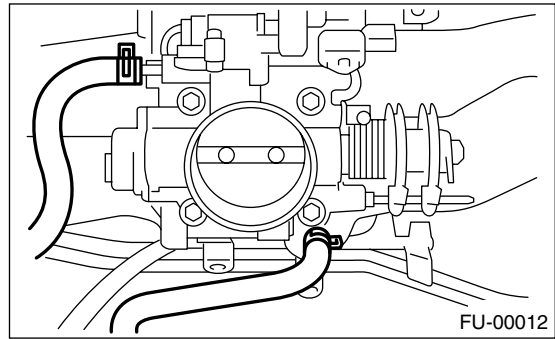

6) Remove the bolts which secure throttle body to intake manifold.

B: INSTALLATION

1) Install in the reverse order of removal.

NOTE:

Always use a new gasket.

Tightening torque:

22 N·m (2.2 kgf-m, 16.2 ft-lb)

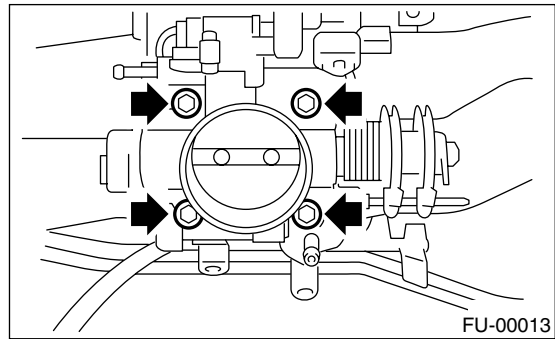

2) Adjust the accelerator cable play. <Ref. to SP(SOHC)-9, INSTALLATION, Accelerator Control Cable.>

INTAKE MANIFOLD

FUEL INJECTION (FUEL SYSTEMS)

3. Intake Manifold

A: REMOVAL

- 1) Release the fuel pressure. <Ref. to FU(TURBO)-52, RELEASING OF FUEL PRESSURE, OPERATION, Fuel.>
- 2) Open the fuel filler flap lid and remove fuel filler cap.
- 3) Disconnect the ground cable from battery.

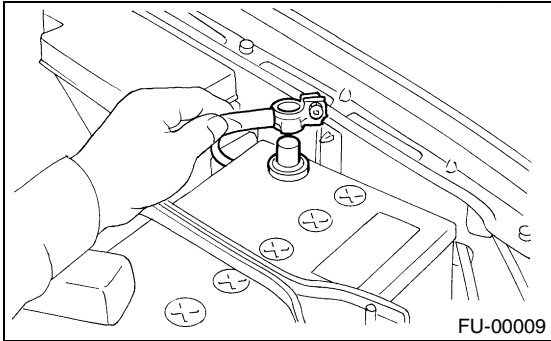

- 4) Lift-up the vehicle.
- 5) Remove the under cover.
- 6) Drain the coolant about 3.0 ℓ (3.2 US qt, 2.6 Imp qt).

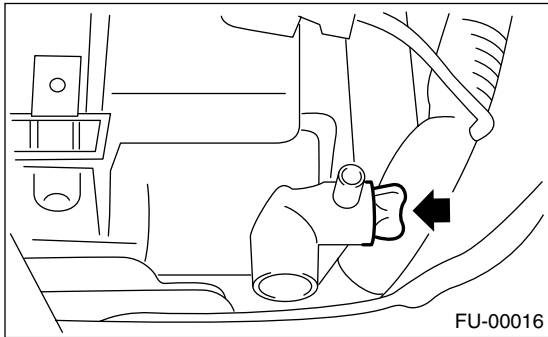

- 7) Remove the air cleaner upper cover and air intake boot. <Ref. to IN(TURBO)-7, REMOVAL, Air Cleaner.>
- 8) Remove the air cleaner element.
- 9) Remove the intercooler. <Ref. to IN(TURBO)-10, REMOVAL, Intercooler.>
- 10) Disconnect the accelerator cable.

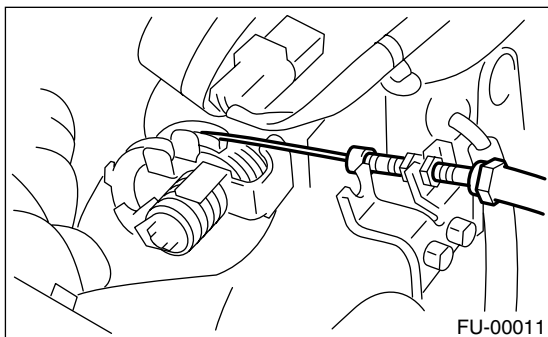

- 11) Remove the coolant filler tank. <Ref. to CO(SOHC)-42, REMOVAL, Coolant Filler Tank.>

- 12) Remove the power steering pump.
 - (1) Remove the front side V-belt. <Ref. to ME(TURBO)-44, REMOVAL, V-belt.>
 - (2) Disconnect the power steering switch connector.

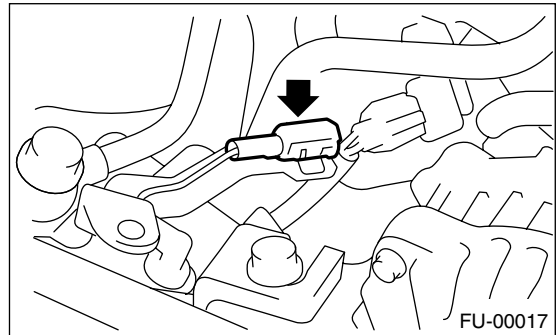

- (3) Remove the bolts which secure power steering pipe brackets to intake manifold.

NOTE:

Do not disconnect the power steering hose.

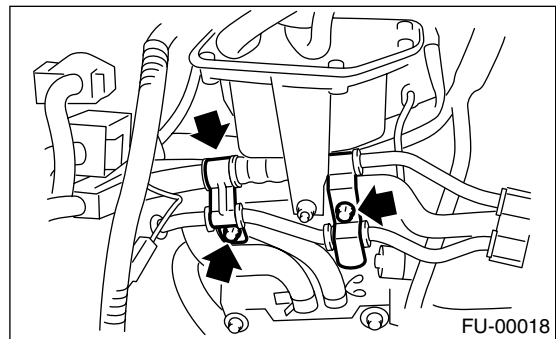

- (4) Remove the bolts which secure power steering pump bracket.

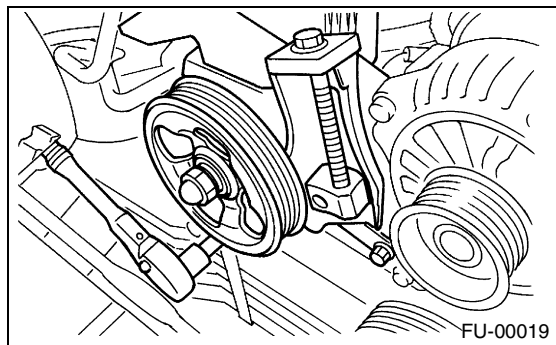

INTAKE MANIFOLD

FUEL INJECTION (FUEL SYSTEMS)

(5) Remove the power steering tank from the bracket by pulling it upward.

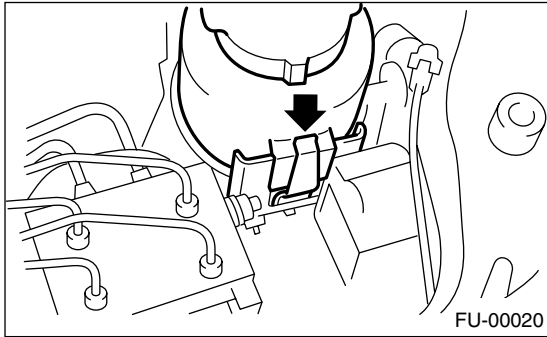

(6) Place the power steering pump on right side wheel apron.

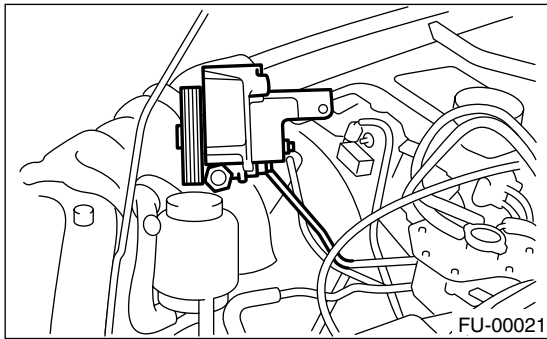

13) Disconnect the emission hose from PCV valve.

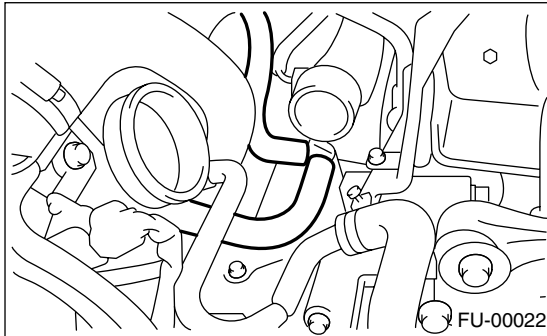

14) Disconnect the engine coolant hoses from throttle body.

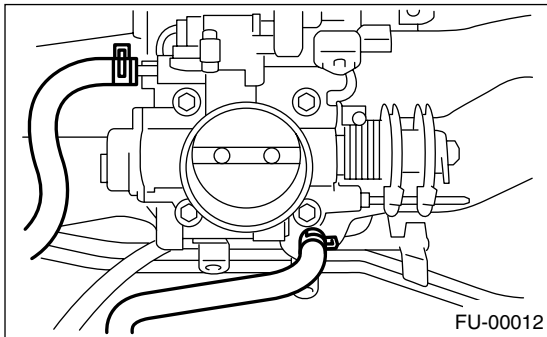

15) Disconnect the brake booster hose.

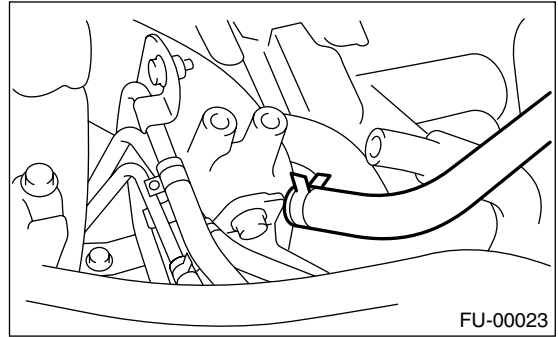

16) Disconnect the pressure hose from intake duct.

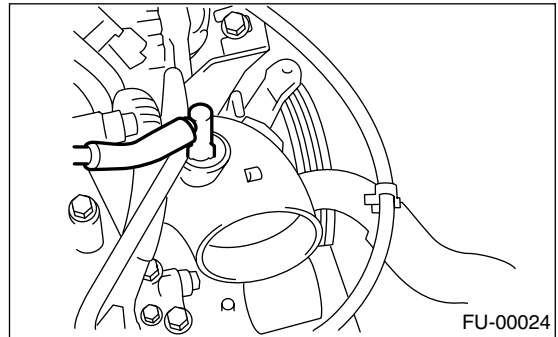

17) Disconnect the engine harness connectors from bulkhead harness connectors.

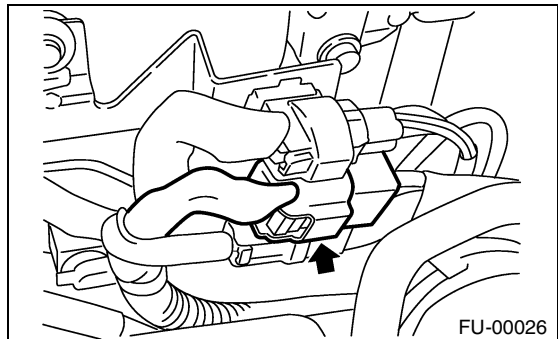
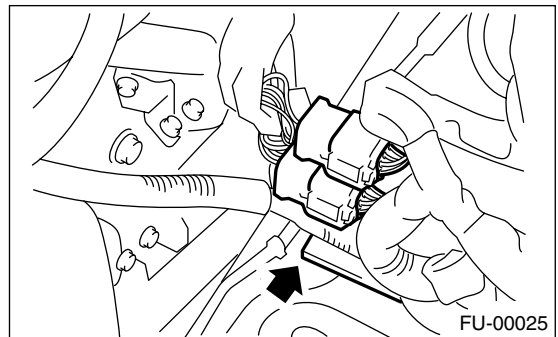

INTAKE MANIFOLD

FUEL INJECTION (FUEL SYSTEMS)

18) Disconnect the connectors from the engine coolant temperature sensor (A), oil pressure switch (B) and crankshaft position sensor (C).

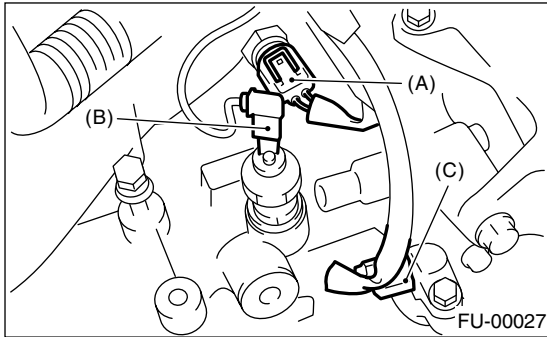

19) Disconnect the knock sensor connector.

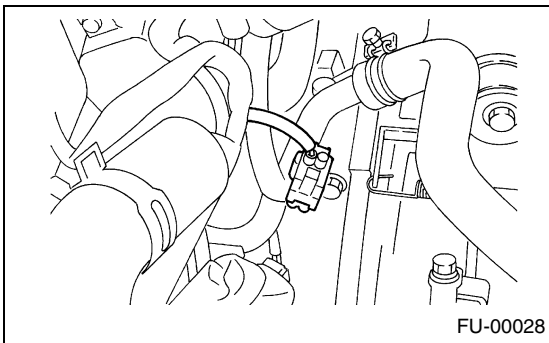

20) Disconnect the connector from crankshaft position sensor.

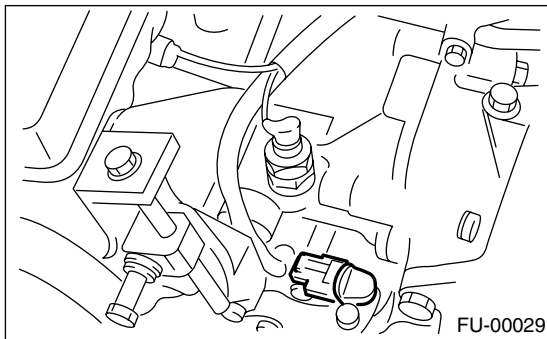

21) Disconnect the connector from camshaft position sensor.

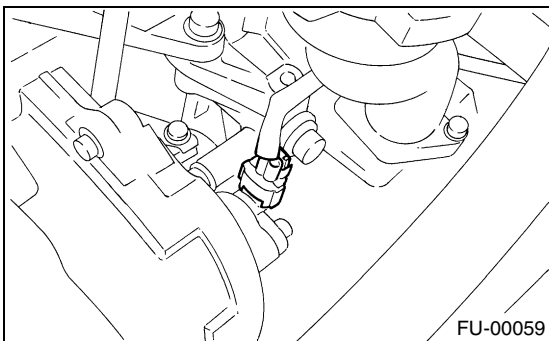

22) Disconnect the connector from ignition coil.

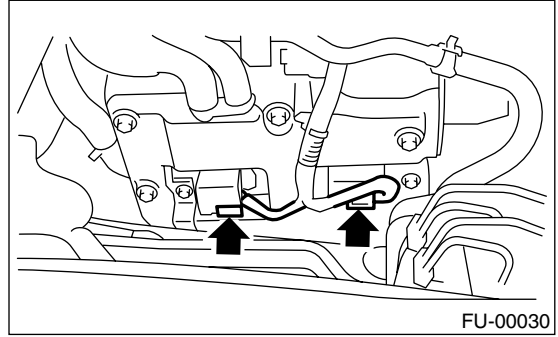

23) Disconnect the engine harness fixed by clip (A) from the bracket.

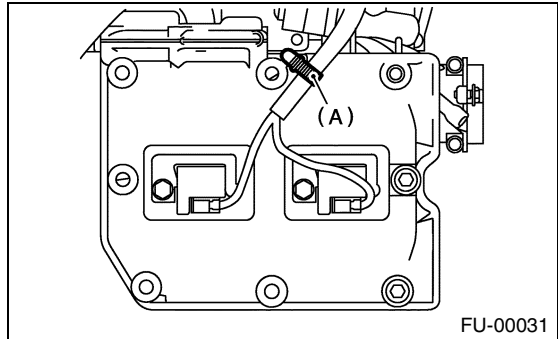

24) Disconnect the fuel delivery hose, return hose and evaporation hose.

CAUTION:

- Do not spill fuel.
- Catch the fuel from hoses in a container or cloth.

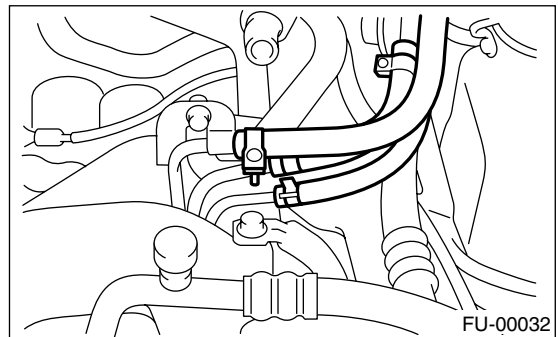

25) Remove the bolts which secure intake manifold to the cylinder heads.

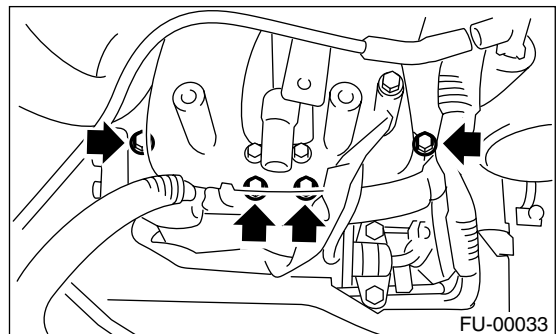

INTAKE MANIFOLD

FUEL INJECTION (FUEL SYSTEMS)

26) Disconnect the ground cable connector.

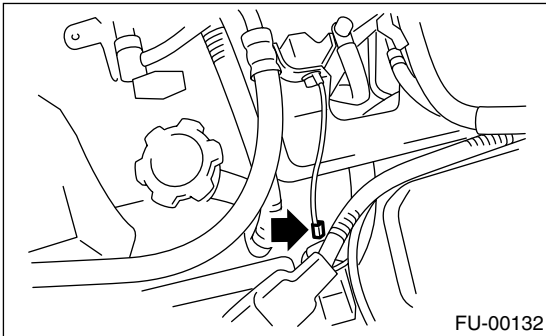
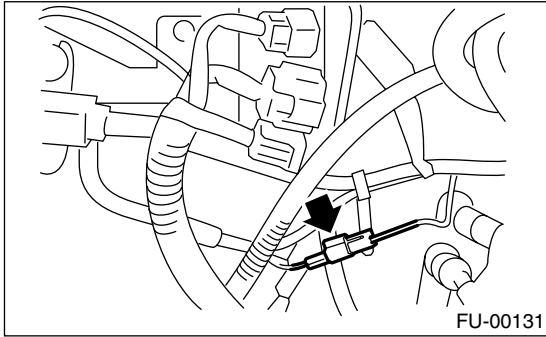

27) Remove the intake manifold.

B: INSTALLATION

1) Install the intake manifold onto cylinder heads.

NOTE:

Always use new gaskets.

Tightening torque:

25 N·m (2.5 kgf-m, 18.4 ft-lb)

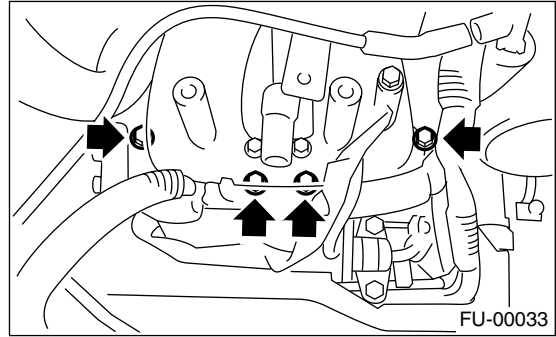

2) Connect the ground cable.

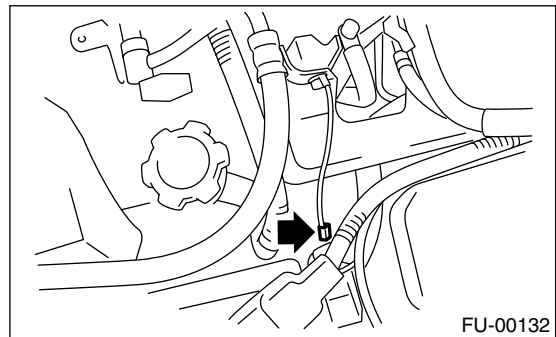
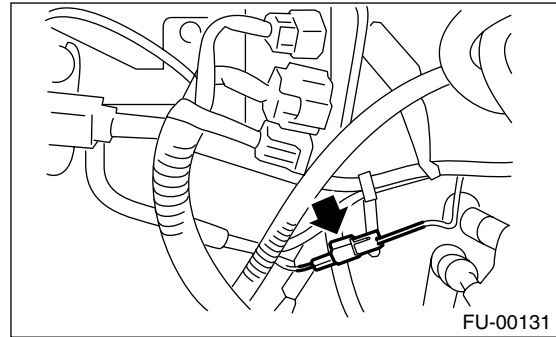

3) Connect the fuel delivery hose, return hose, and evaporation hose.

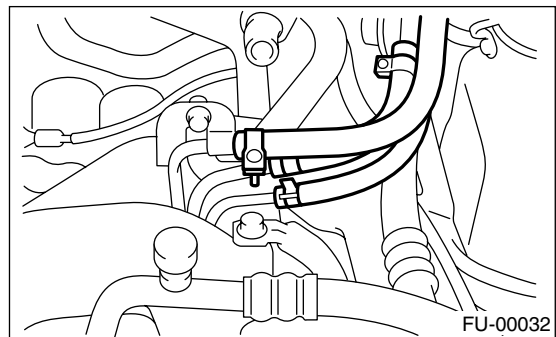

INTAKE MANIFOLD

FUEL INJECTION (FUEL SYSTEMS)

4) Connect the connector to the oil pressure switch (B), crankshaft position sensor (C) and engine coolant temperature sensor (A).

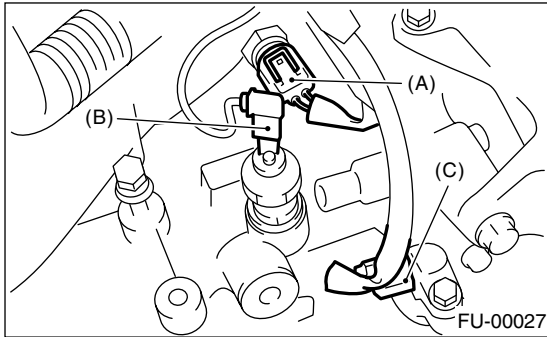

5) Connect the connector to knock sensor.

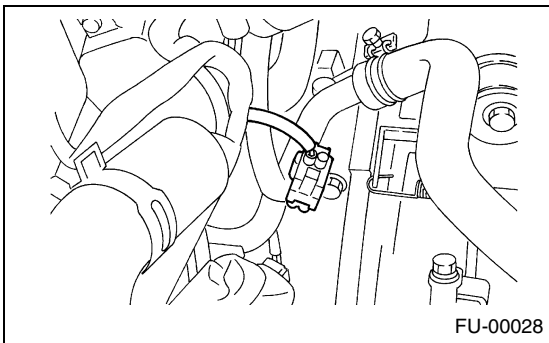

6) Connect the connector to crankshaft position sensor.

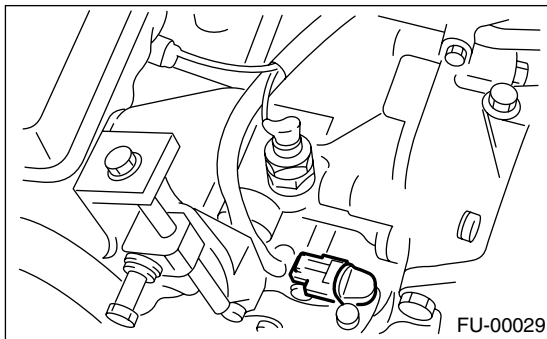

7) Connect the connector to camshaft position sensor.

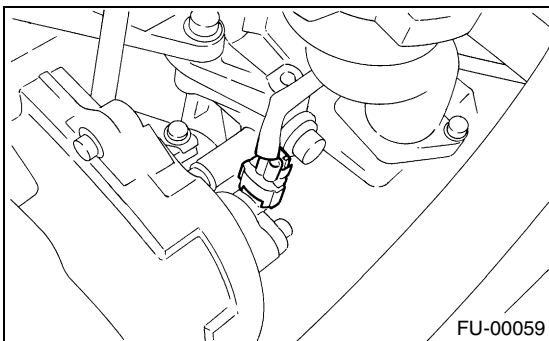

8) Connect the connector to ignition coil.

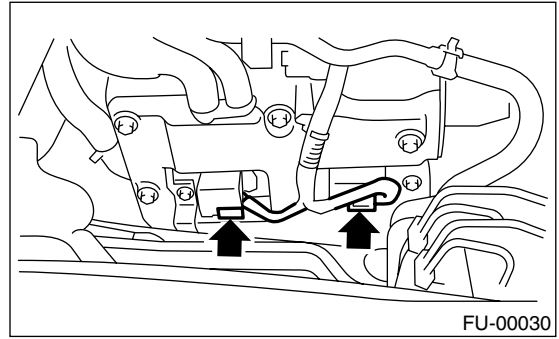

9) Connect the engine harness with clip (A) to the bracket.

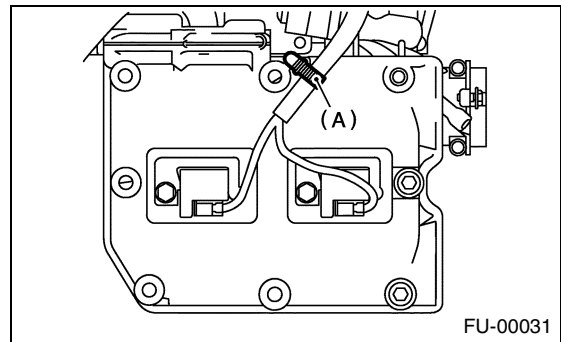

10) Connect the engine harness connector to bulk-head harness connectors.

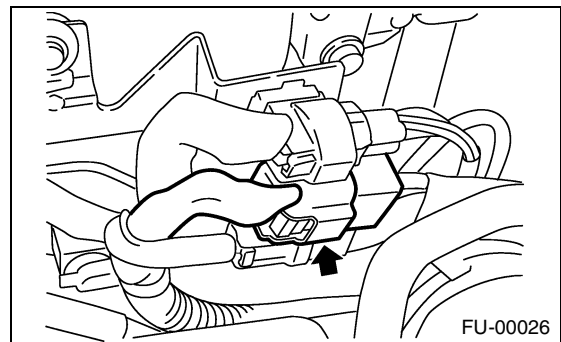
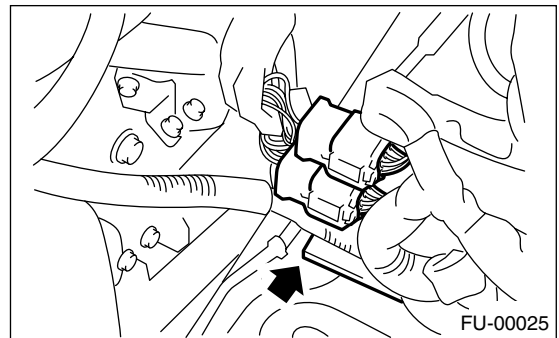

INTAKE MANIFOLD

FUEL INJECTION (FUEL SYSTEMS)

11) Connect the brake booster vacuum hose.

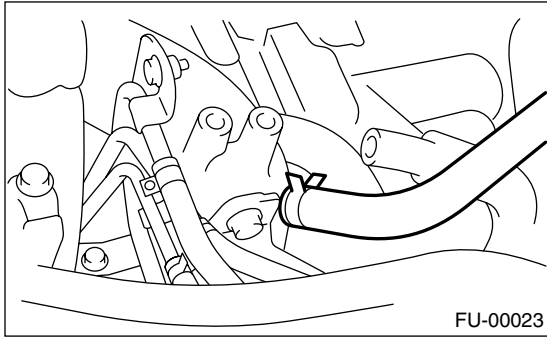

12) Connect the engine coolant hoses to throttle body.

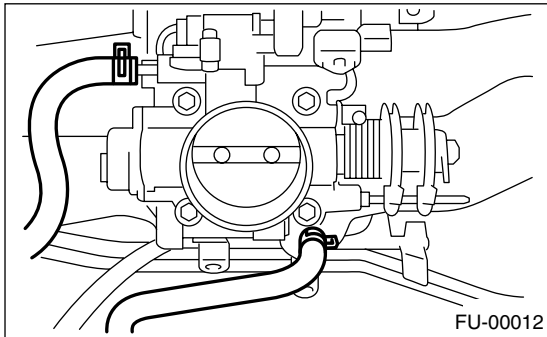

13) Connect the emission hose to PCV valve.

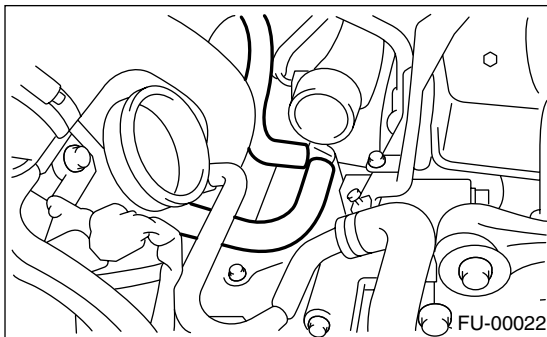

14) Connect the pressure hose to intake duct.

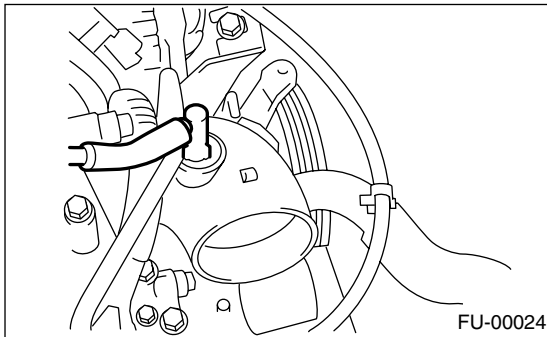

15) Install the power steering pump.

(1) Install the power steering tank on bracket.

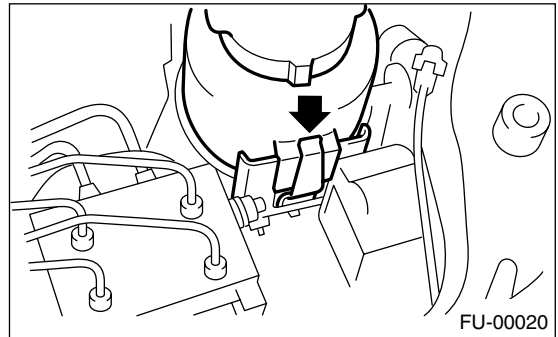

(2) Connect the connector to power steering pump switch.

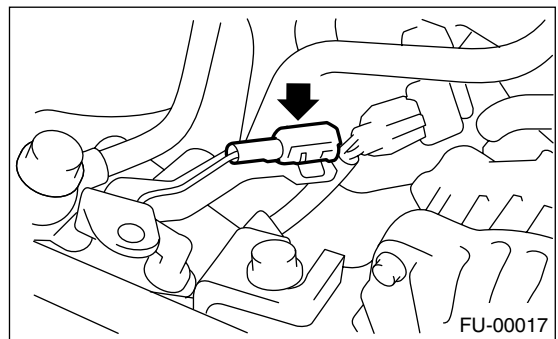

(3) Install the power steering pump, and then tighten the bolts.

Tightening torque:

22 N·m (2.2 kgf-m, 16.2 ft-lb)

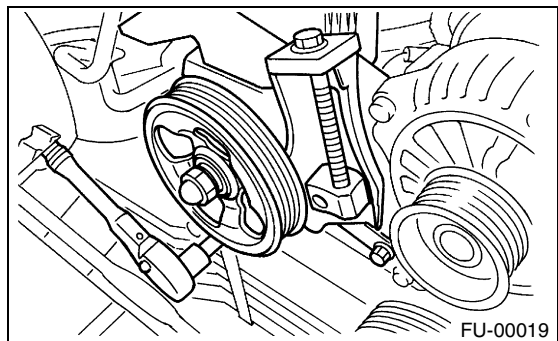

(4) Install the power steering pipe brackets on right side intake manifold.

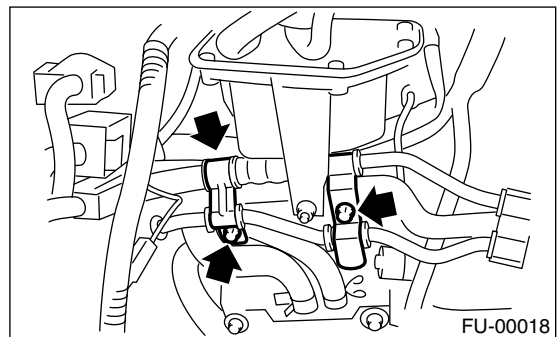

INTAKE MANIFOLD

FUEL INJECTION (FUEL SYSTEMS)

(5) Install the front side V-belt. <Ref. to ME(TURBO)-44, REMOVAL, V-belt.>

16) Install the coolant filler tank. <Ref. to CO(SOHC)-42, INSTALLATION, Coolant Filler Tank.>

17) Connect the accelerator cable. <Ref. to SP(SOHC)-9, INSTALLATION, Accelerator Control Cable.>

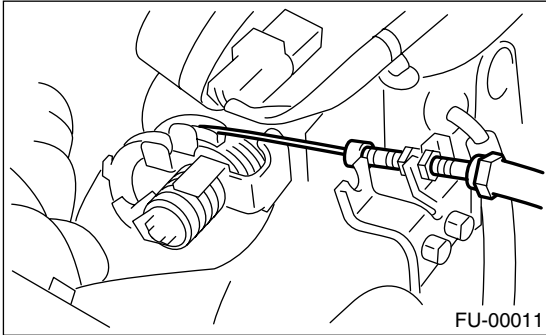

18) Install the intercooler. <Ref. to IN(TURBO)-11, INSTALLATION, Intercooler.>

19) Install the air cleaner element.

20) Install the air cleaner upper cover and air intake duct as a unit. <Ref. to IN(TURBO)-7, INSTALLATION, Air Cleaner.>

21) Connect the connector to fuel pump relay.

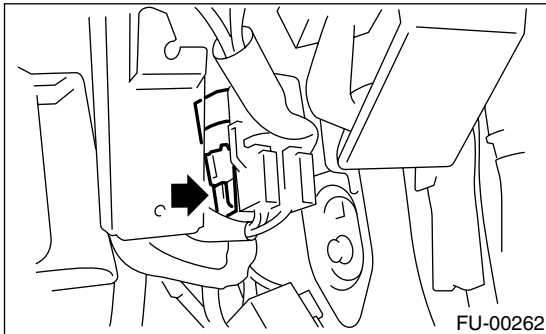

22) Connect the battery ground cable to battery.

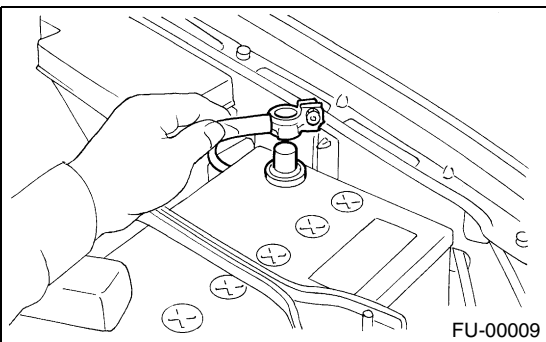

23) Lift-up the vehicle.

24) Install the under cover.

25) Fill the coolant. <Ref. to CO(SOHC)-18, FILLING OF ENGINE COOLANT, Engine Coolant.>

C: DISASSEMBLY

1) Remove the fuel pipe protector LH.

NOTE:

Bolt (A) is tightened together with ground cable.

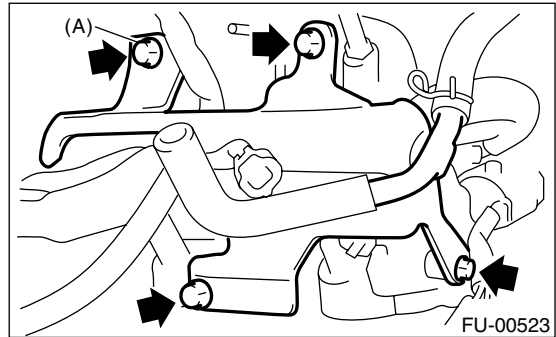

2) Remove the fuel pipe protector RH.

NOTE:

Bolt (A) is tightened together with ground cable.

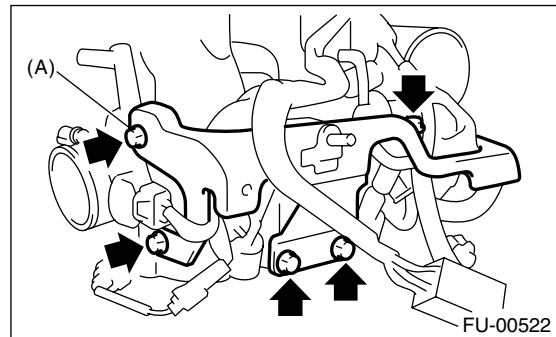

3) Remove the engine ground cable from intake manifold.

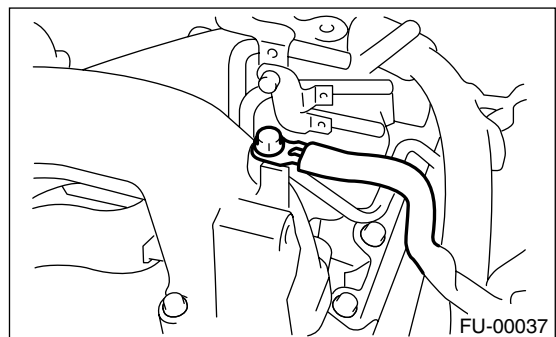
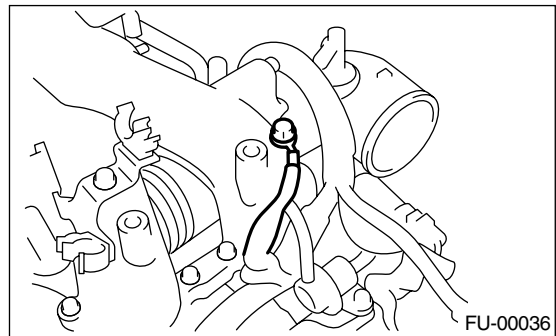

INTAKE MANIFOLD

FUEL INJECTION (FUEL SYSTEMS)

4) Disconnect the connector from the throttle position sensor (A), idle air control solenoid valve (B) and pressure sensor (C).

5) Disconnect the engine harness fixed by clip (D) from the intake manifold.

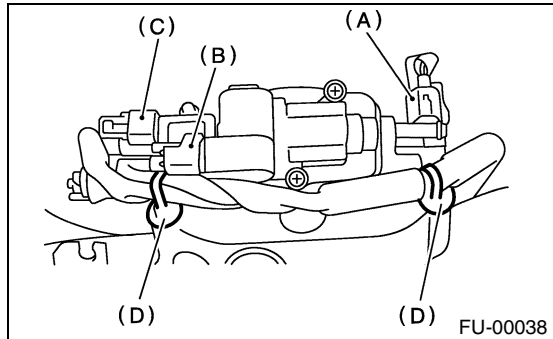

6) Remove the throttle body from intake manifold.

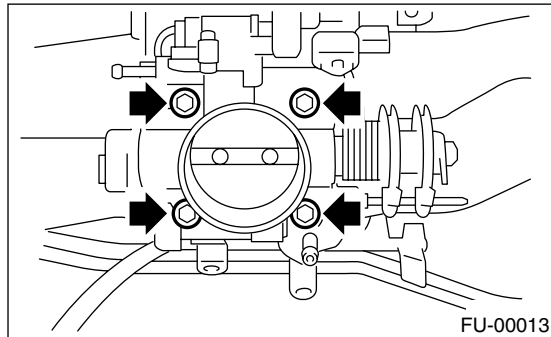

7) Disconnect the connector from fuel injector.

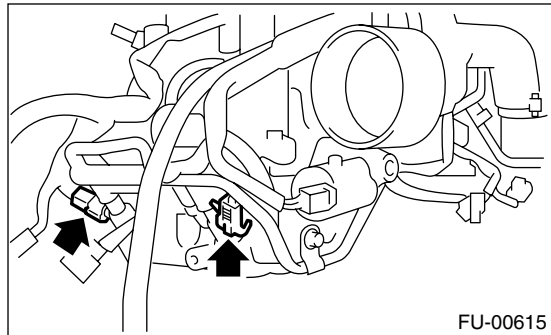

8) Disconnect the connector from tumble generator valve actuator.

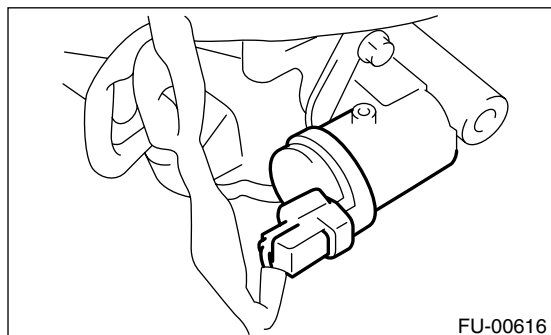

9) Disconnect the connector from tumble generator valve sensor.

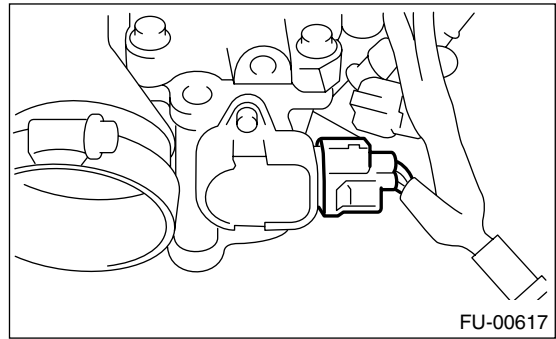

10) Disconnect the connector from purge control solenoid valve.

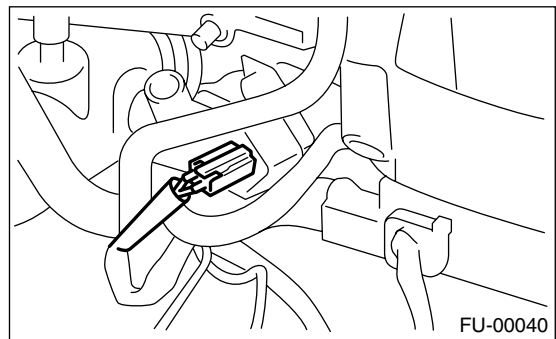

11) Remove the purge control solenoid valve.

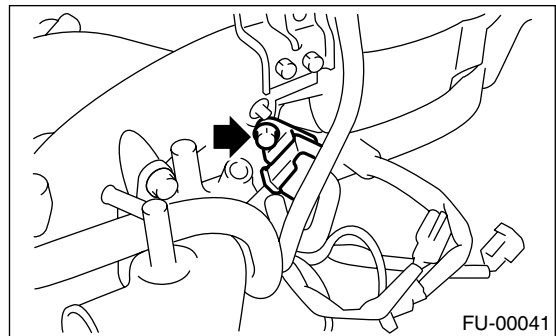

12) Disconnect the evaporation hose from intake manifold.

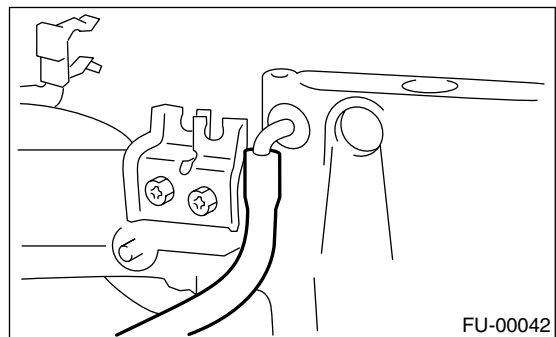

INTAKE MANIFOLD

FUEL INJECTION (FUEL SYSTEMS)

13) Disconnect the evaporation hose from purge valve.

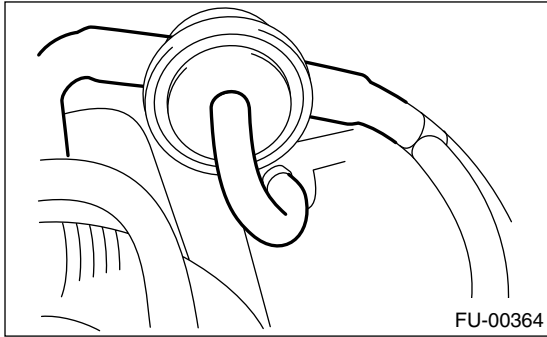

14) Remove the two bolts which hold fuel pipes on the left side of intake manifold.

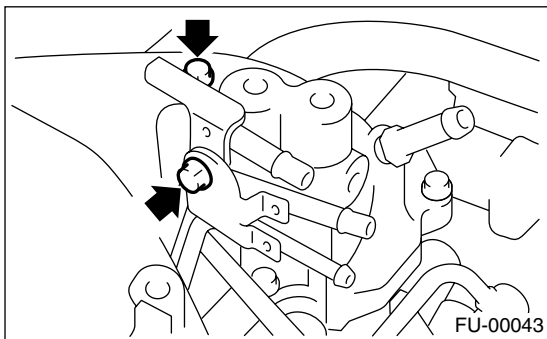

15) Remove the bolts which hold fuel injector pipe onto intake manifold.

• LH SIDE

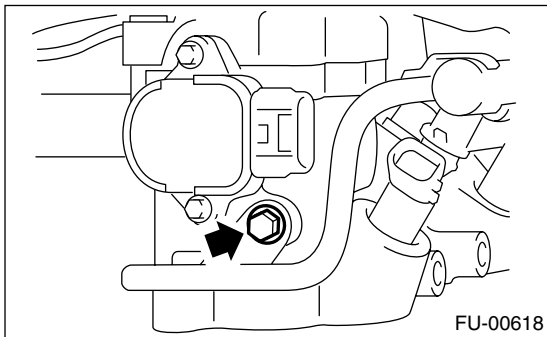
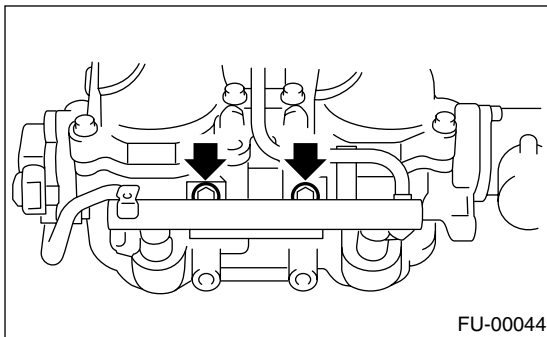

• RH SIDE

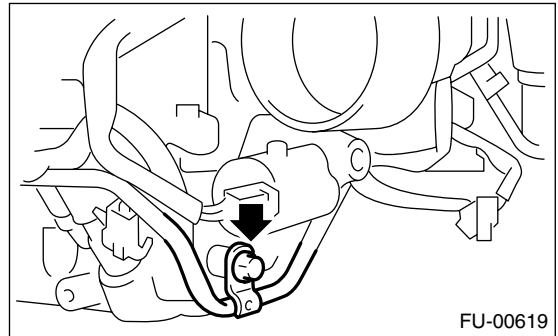
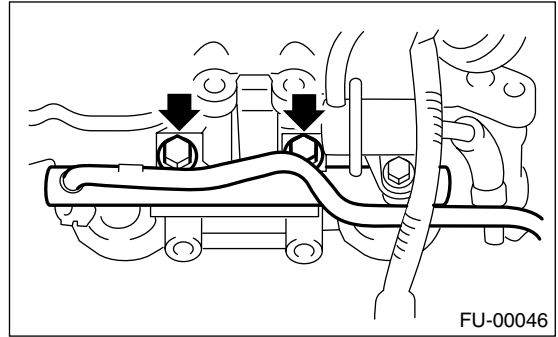

16) Remove the fuel injector.

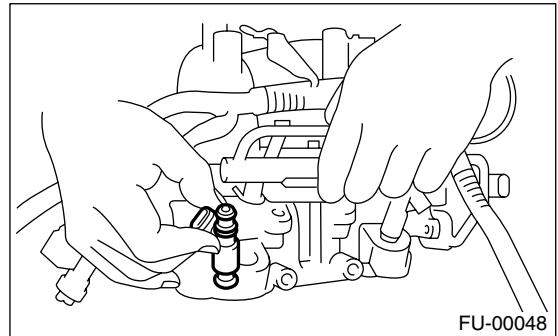

17) Remove the harness bracket which holds engine harness onto intake manifold.

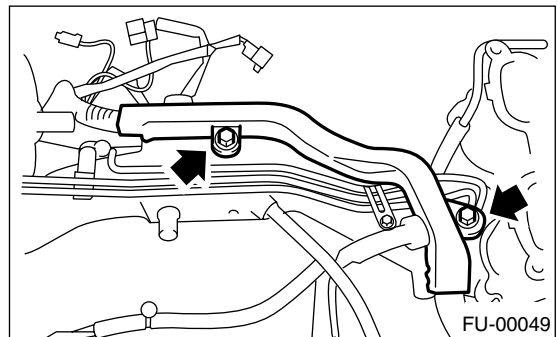

18) Remove the engine harness from intake manifold.

INTAKE MANIFOLD

FUEL INJECTION (FUEL SYSTEMS)

- 19) Loosen the clamp which holds front left side fuel hose to injector pipe, and remove the pipe from clamp.

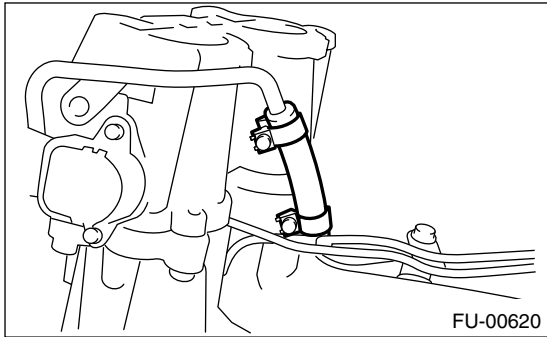

- 20) Remove the fuel injector pipe LH.
21) Remove the bolts which install fuel pipe on intake manifold.

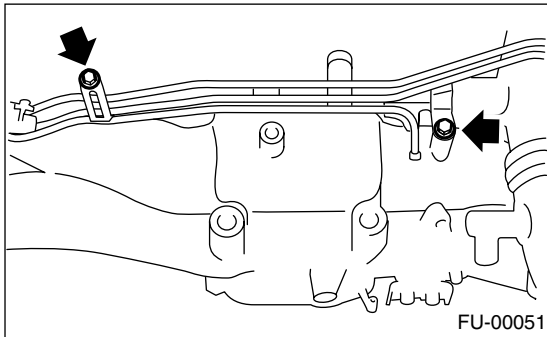

- 22) Remove the fuel pipe assembly and pressure regulator from intake manifold.
23) Remove the intake duct from intake manifold.

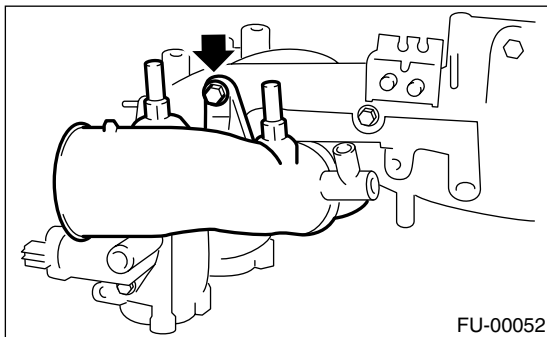

- 24) Remove the intake manifold.

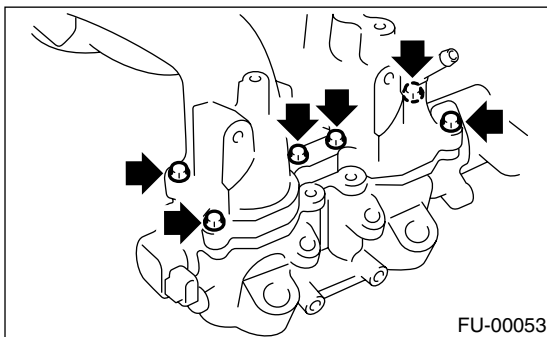

D: ASSEMBLY

NOTE:

Replace the gasket with a new one.

- 1) Install the intake manifold.

Tightening torque:

8.25 N·m (0.84 kgf-m, 6.1 ft-lb)

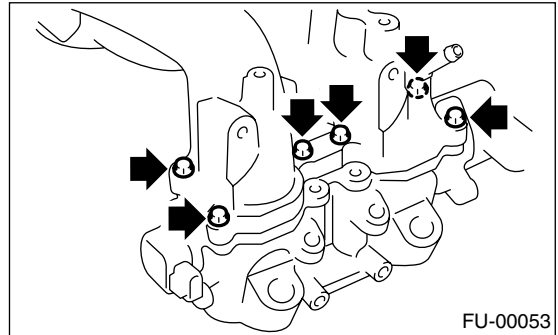

- 2) Install the air intake duct to intake manifold.

Tightening torque:

19 N·m (1.9 kgf-m, 14.0 ft-lb)

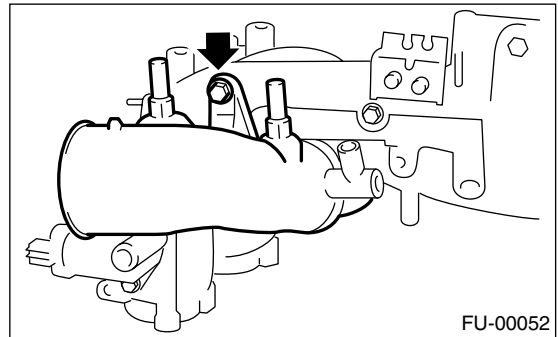

- 3) Install the fuel pipe assembly and pressure regulator to intake manifold.

Tightening torque:

4.9 N·m (0.5 kgf-m, 3.6 ft-lb)

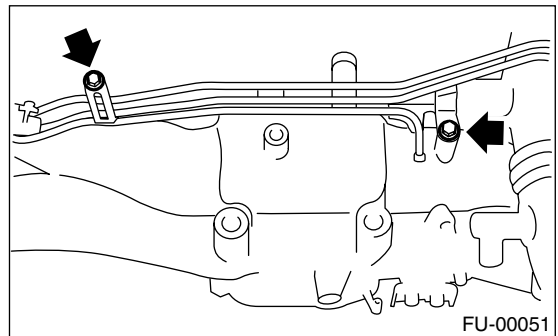

- 4) Install the fuel injector pipe LH.

INTAKE MANIFOLD

FUEL INJECTION (FUEL SYSTEMS)

5) Connect the left side fuel hose to injector pipe, and tighten the clamp screw.

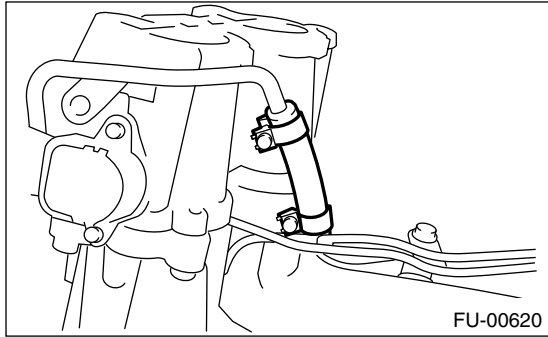

6) Install the engine harness to intake manifold.
7) Install the harness bracket which holds engine harness onto intake manifold.

Tightening torque:

19 N·m (1.9 kgf·m, 14.0 ft·lb)

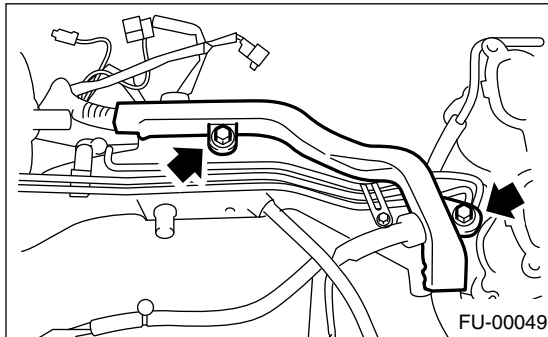

8) Install the fuel injector.

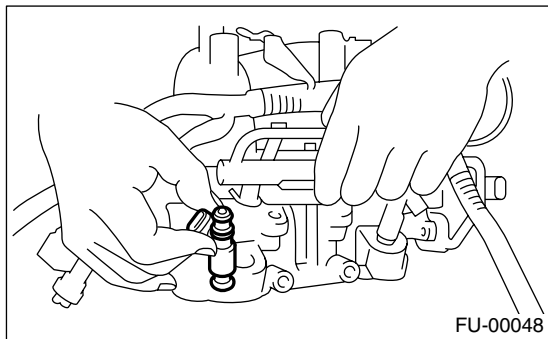

9) Tighten the bolts which install fuel injector pipe onto intake manifold.

Tightening torque:

19 N·m (1.9 kgf·m, 14.0 ft·lb)

• LH SIDE

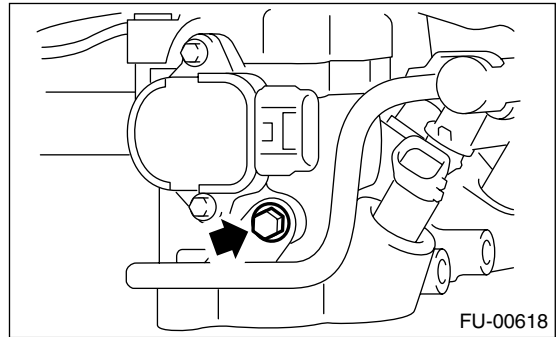
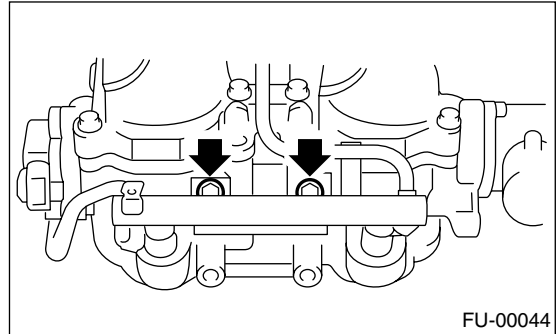

• RH SIDE

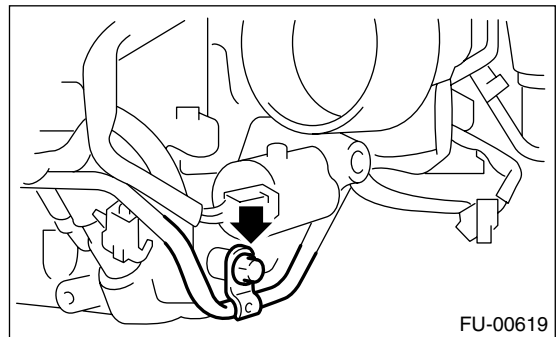
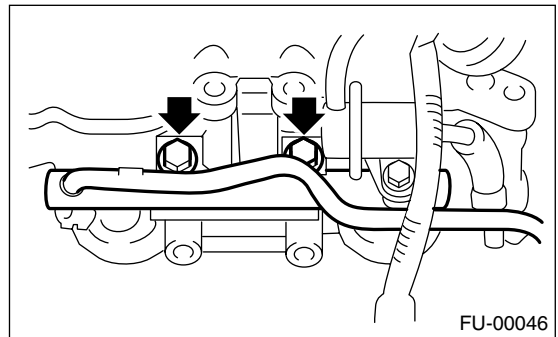

INTAKE MANIFOLD

FUEL INJECTION (FUEL SYSTEMS)

10) Tighten the two bolts which install fuel pipes on the left side of intake manifold.

Tightening torque:

4.9 N·m (0.5 kgf·m, 3.6 ft·lb)

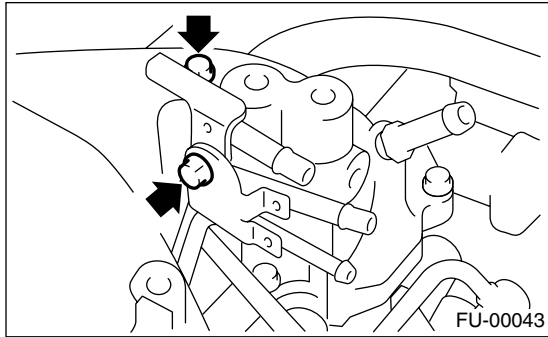

11) Connect the evaporation hoses to purge valve.

NOTE:

Connect the evaporation hose as shown in the figure.

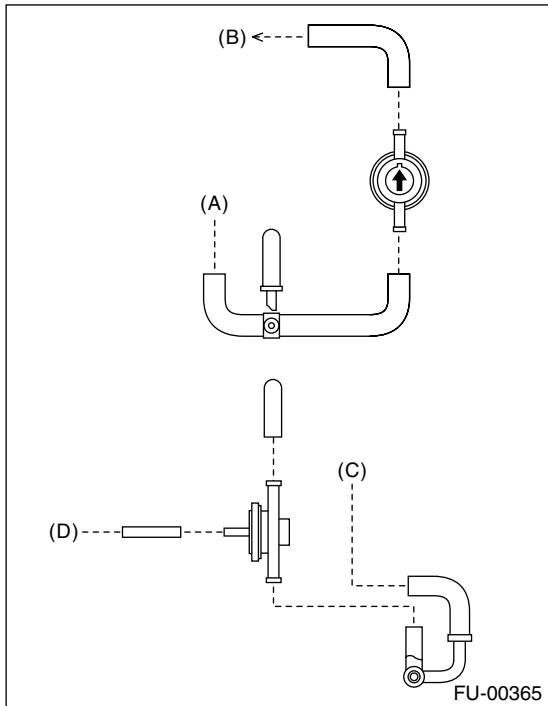

- (A) To fuel pipe ASSY
- (B) To intake duct
- (C) To purge control solenoid valve
- (D) To intake manifold

12) Connect the evaporation hose to intake manifold.

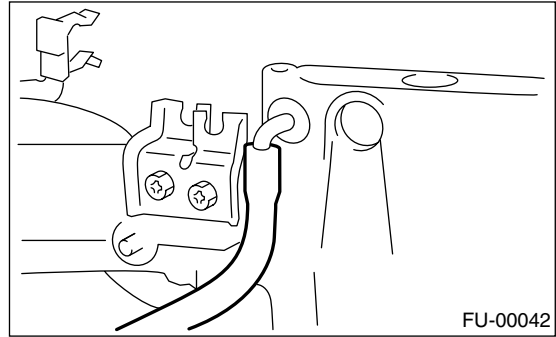

13) Install the purge control solenoid valve.

Tightening torque:

16 N·m (1.6 kgf·m, 11.8 ft·lb)

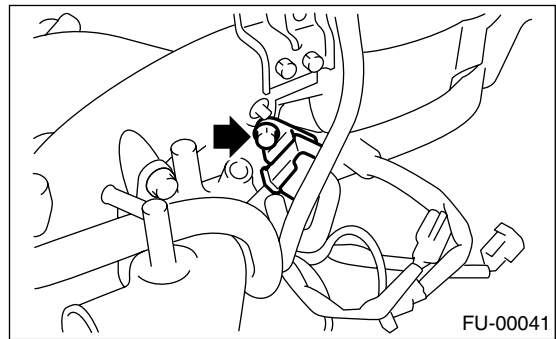

14) Connect the hoses to purge control solenoid valve.

NOTE:

Connect the evaporation hose as shown in the figure.

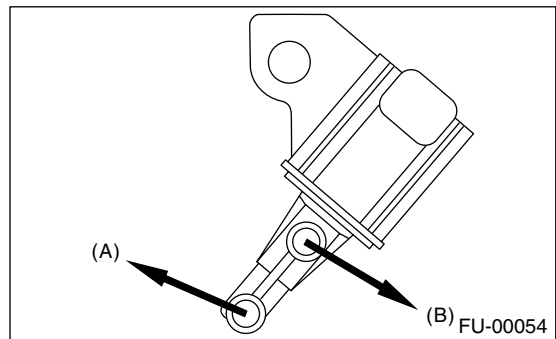

- (A) To intake manifold
- (B) To fuel pipe

INTAKE MANIFOLD

FUEL INJECTION (FUEL SYSTEMS)

15) Connect the connector to purge control solenoid valve.

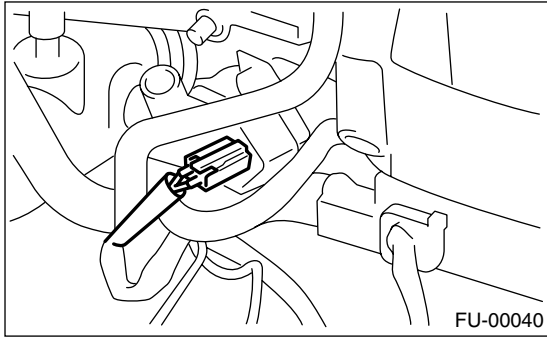

16) Connect the connector to tumble generator valve sensor.

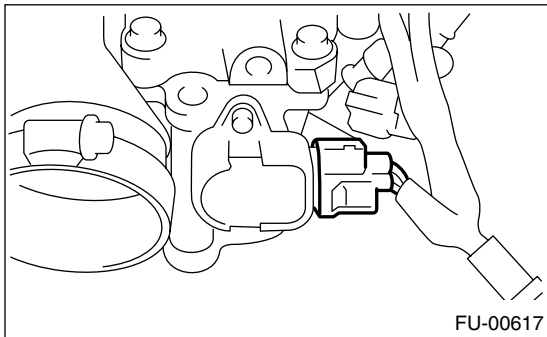

17) Connect the connector to tumble generator valve actuator.

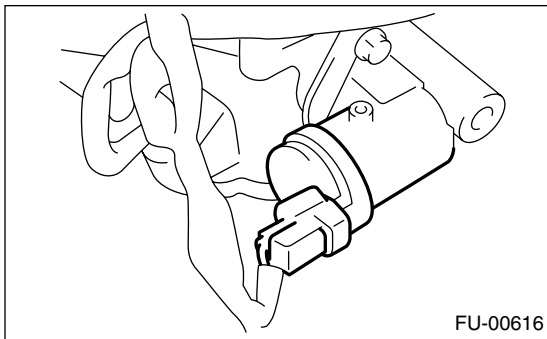

18) Connect the connector to fuel injector.

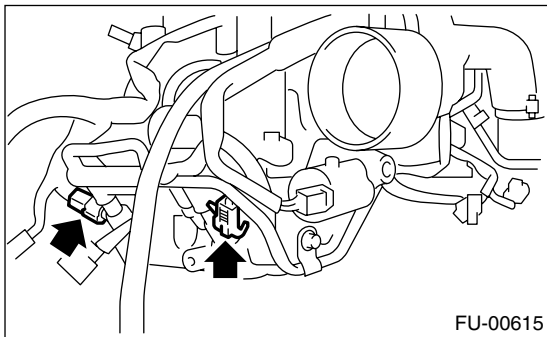

19) Install the throttle body to intake manifold.

NOTE:
Replace the gasket with a new one.

Tightening torque:
22 N·m (2.2 kgf-m, 16.2 ft-lb)

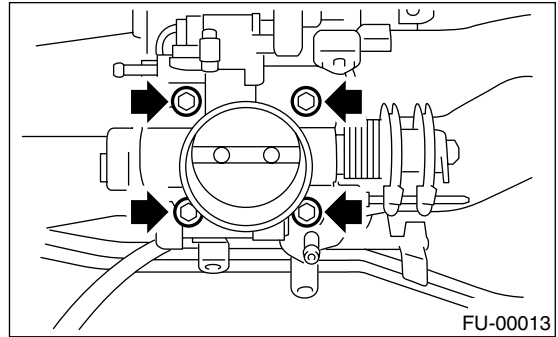

20) Connect the connector to the throttle position sensor (A), idle air control solenoid valve (B) and pressure sensor (C).

21) Connect the engine harness with clip (D) to the intake manifold. (MT vehicles)

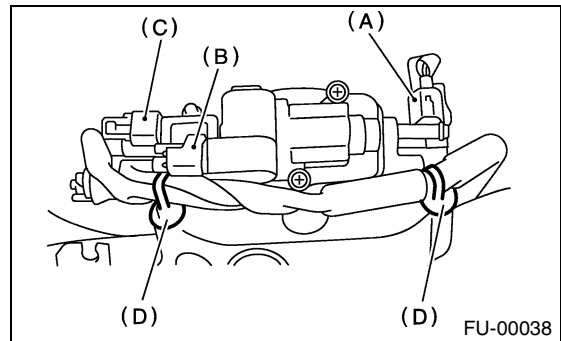

22) Install the engine ground cable to intake manifold.

Tightening torque:
19 N·m (1.9 kgf-m, 14.0 ft-lb)

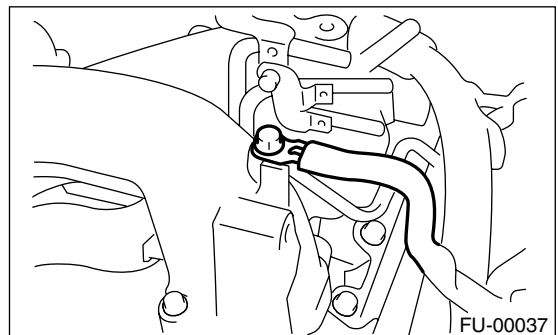
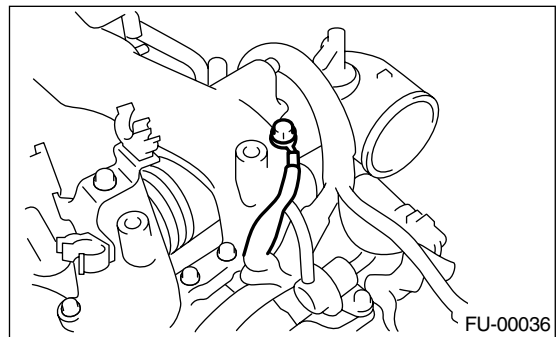

23) Install the fuel pipe protector RH.

NOTE:

Securely tighten bolt (A) together with ground cable.

Tightening torque:

19 N·m (1.9 kgf·m, 14.0 ft·lb)

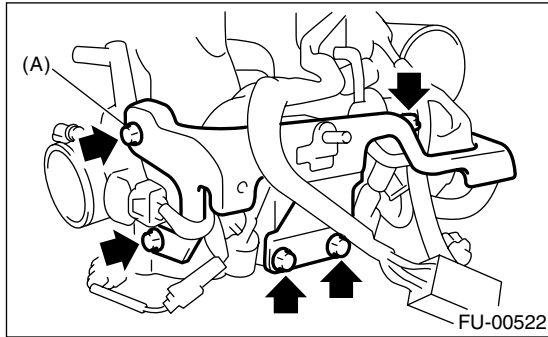

24) Install the fuel pipe protector LH.

NOTE:

Securely tighten bolt (A) together with ground cable.

Tightening torque:

19 N·m (1.9 kgf·m, 14.0 ft·lb)

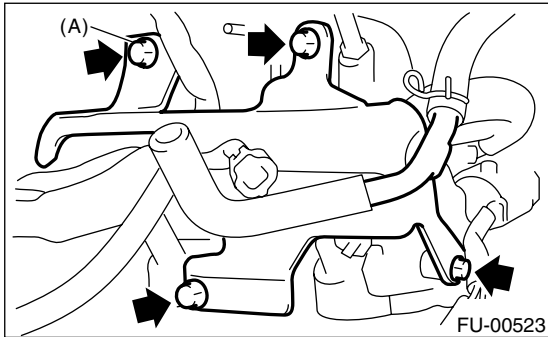

E: INSPECTION

Make sure the fuel pipe and fuel hoses are not cracked and that connections are tight.

ENGINE COOLANT TEMPERATURE SENSOR

FUEL INJECTION (FUEL SYSTEMS)

4. Engine Coolant Temperature Sensor

A: REMOVAL

1) Disconnect the ground cable from battery.

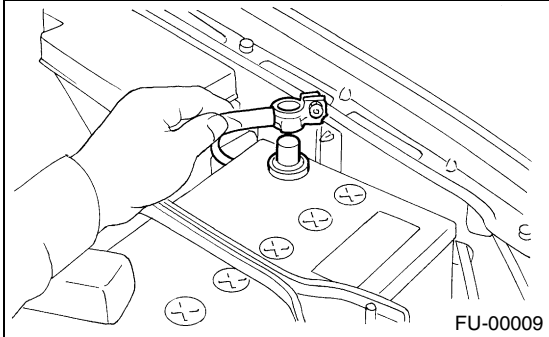

2) Remove the generator <Ref. to SC(SOHC)-15, REMOVAL, Generator.>

3) Drain the engine coolant. <Ref. to CO(SOHC)-18, DRAINING OF ENGINE COOLANT, REPLACEMENT, Engine Coolant.>

4) Disconnect the connector from engine coolant temperature sensor.

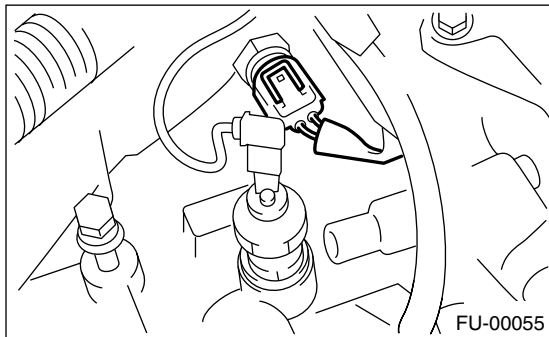

5) Remove the engine coolant temperature sensor.

B: INSTALLATION

Install in the reverse order of removal.

Tightening torque:

18 N·m (1.8 kgf-m, 13.3 ft-lb)

CRANKSHAFT POSITION SENSOR

FUEL INJECTION (FUEL SYSTEMS)

5. Crankshaft Position Sensor

A: REMOVAL

1) Disconnect the ground cable from battery.

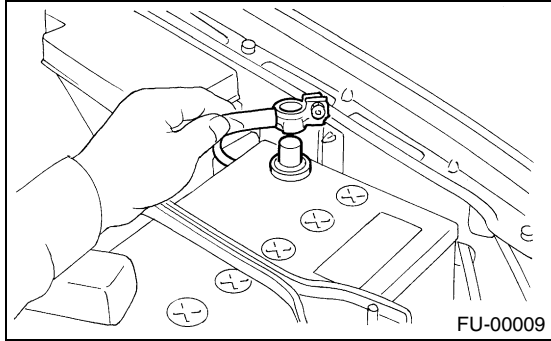

2) Remove the bolt which installs crankshaft position sensor to cylinder block.

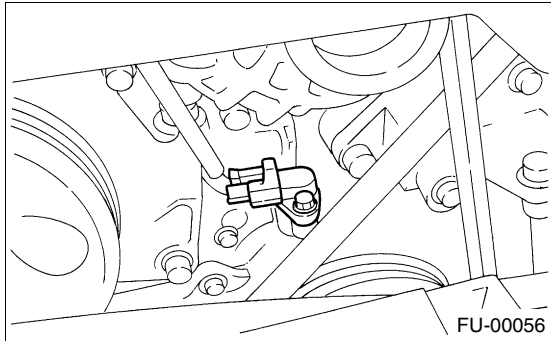

3) Remove the crankshaft position sensor, and disconnect the connector from it.

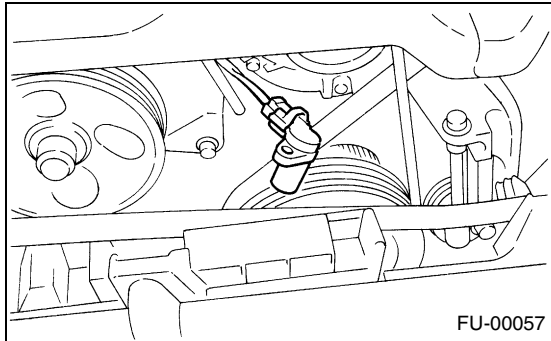

B: INSTALLATION

Install in the reverse order of removal.

Tightening torque:

T: 6.4 N·m (0.65 kgf-m, 4.7 ft-lb)

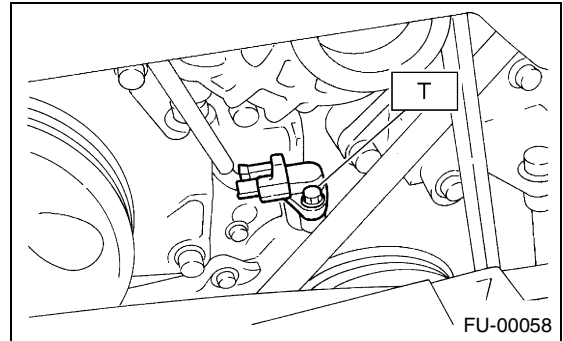

CAMSHAFT POSITION SENSOR

FUEL INJECTION (FUEL SYSTEMS)

6. Camshaft Position Sensor

A: REMOVAL

1) Disconnect the ground cable from battery.

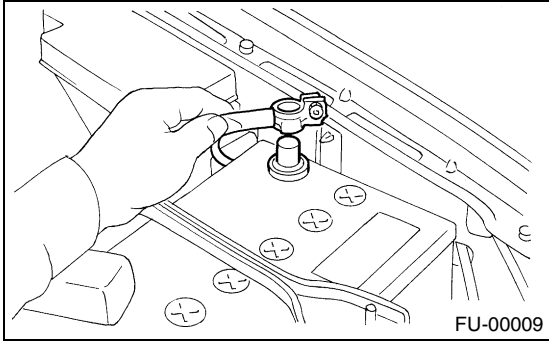

2) Disconnect the connector from camshaft position sensor.

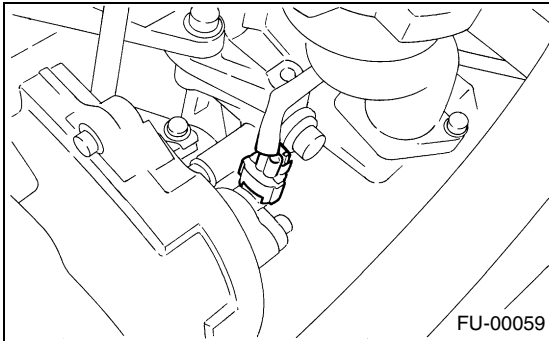

3) Remove the camshaft position sensor from camshaft support LH.

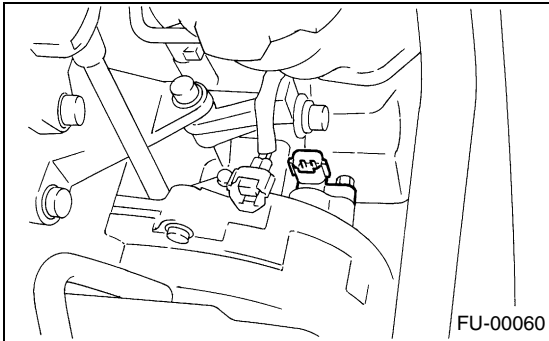

B: INSTALLATION

Install in the reverse order of removal.

Tightening torque:

T: 6.4 N·m (0.65 kgf-m, 4.7 ft-lb)

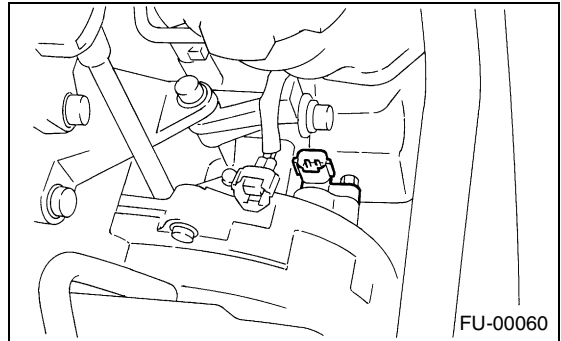

7. Knock Sensor

A: REMOVAL

- 1) Disconnect the ground cable from battery.

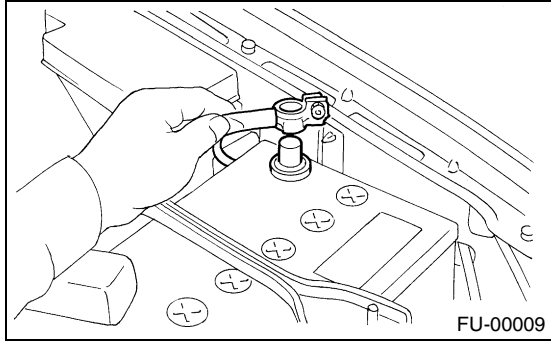

- 2) Remove the intercooler. <Ref. to IN(TURBO)-10, REMOVAL, Intercooler.>
- 3) Disconnect the knock sensor connector.

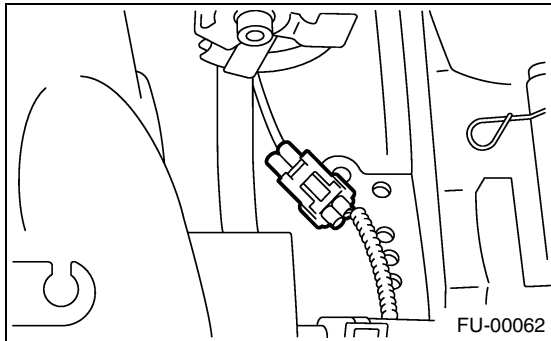

- 4) Remove the knock sensor from cylinder block.

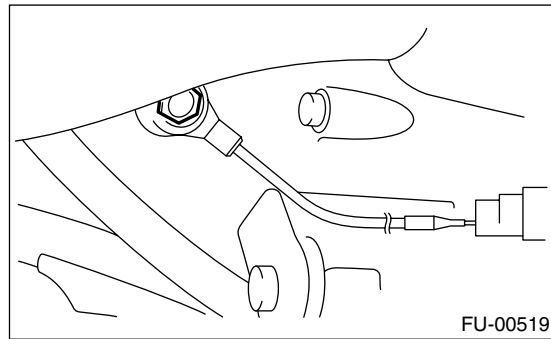

B: INSTALLATION

- 1) Install the knock sensor to cylinder block.

Tightening torque:

24 N·m (2.4 kgf-m, 17.4 ft-lb)

NOTE:

The extraction area of the knock sensor cord must be positioned at a 60° angle relative to engine rear.

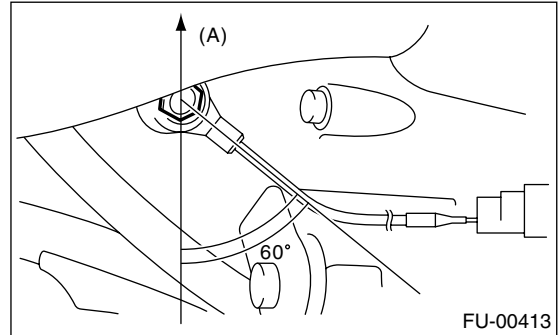

(A) Front side

- 2) Connect the knock sensor connector.

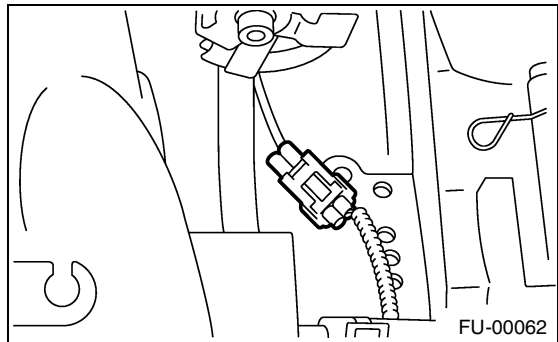

- 3) Install the intercooler. <Ref. to IN(TURBO)-11, INSTALLATION, Intercooler.>
- 4) Connect the battery ground cable to battery.

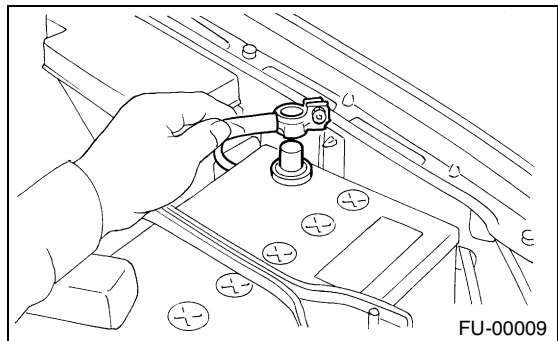

THROTTLE POSITION SENSOR

FUEL INJECTION (FUEL SYSTEMS)

8. Throttle Position Sensor

A: REMOVAL

1) Disconnect the ground cable from battery.

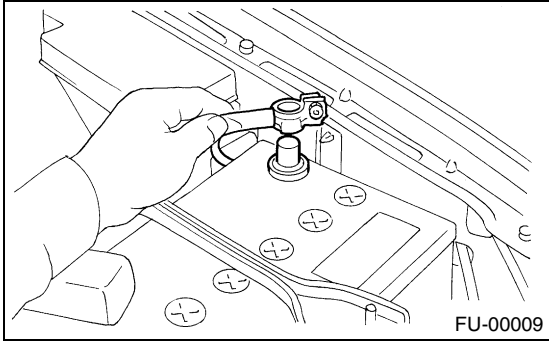

2) Remove the intercooler. <Ref. to IN(TURBO)-10, REMOVAL, Intercooler.>

3) Disconnect the connector from throttle position sensor.

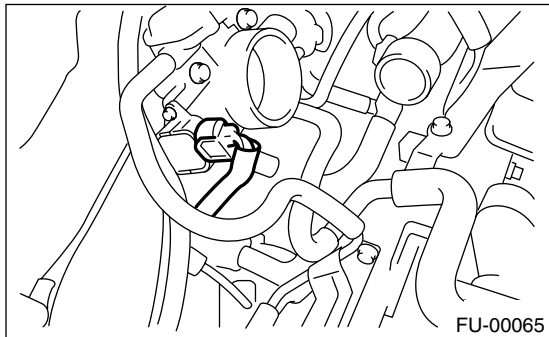

4) Remove the throttle position sensor holding screws, and remove it.

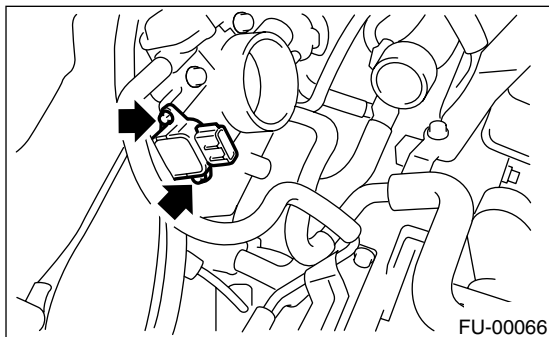

B: INSTALLATION

Install in the reverse order of removal.

Tightening torque:

1.6 N·m (0.16 kgf·m, 1.2 ft·lb)

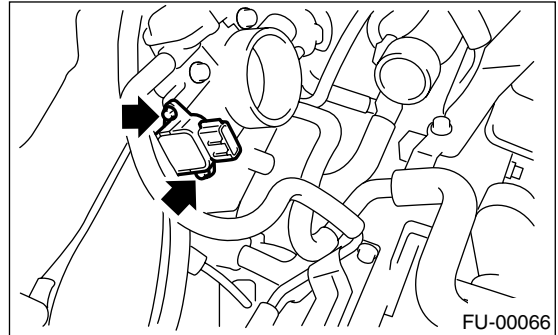

MASS AIR FLOW AND INTAKE AIR TEMPERATURE SENSOR

FUEL INJECTION (FUEL SYSTEMS)

9. Mass Air Flow and Intake Air Temperature Sensor

A: REMOVAL

- 1) Disconnect the ground cable from battery.

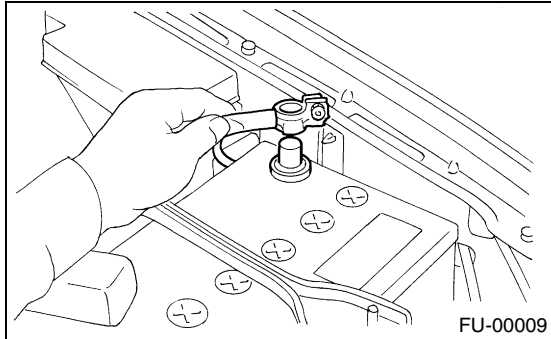

- 2) Disconnect the connector mass air flow and intake air temperature sensor.
- 3) Remove the mass air flow and intake air temperature sensor.

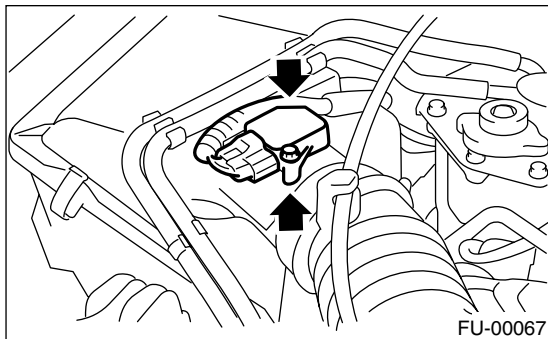

B: INSTALLATION

Install in the reverse order of removal.

Tightening torque:

1.7N·m (0.17 kgf-m, 1.2 ft-lb)

PRESSURE SENSOR

FUEL INJECTION (FUEL SYSTEMS)

10. Pressure Sensor

A: REMOVAL

1) Disconnect the ground cable from battery.

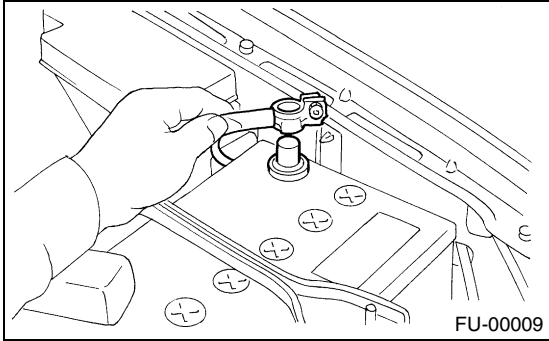

2) Remove the idle air control solenoid valve. <Ref. to FU(TURBO)-35, REMOVAL, Idle Air Control Solenoid Valve.>

3) Disconnect the connectors from pressure sensor.

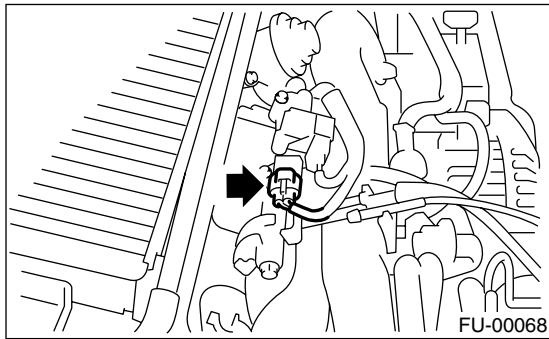

4) Remove the pressure sensor from throttle body.

B: INSTALLATION

Install in the reverse order of removal.

NOTE:

Replace the O-ring for the pressure sensor with new ones.

Tightening torque:

1.6 N·m (0.16 kgf-m, 1.2 ft-lb)

IDLE AIR CONTROL SOLENOID VALVE

FUEL INJECTION (FUEL SYSTEMS)

11. Idle Air Control Solenoid Valve

A: REMOVAL

1) Disconnect the ground cable from battery.

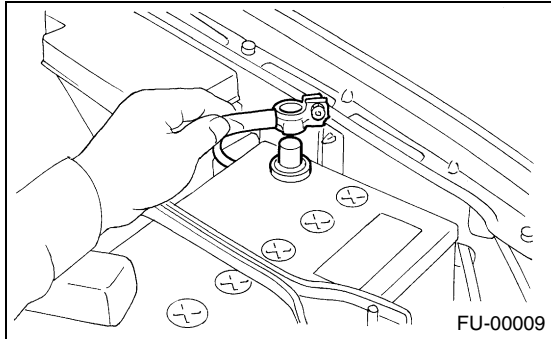

2) Disconnect the connector from idle air control solenoid valve.

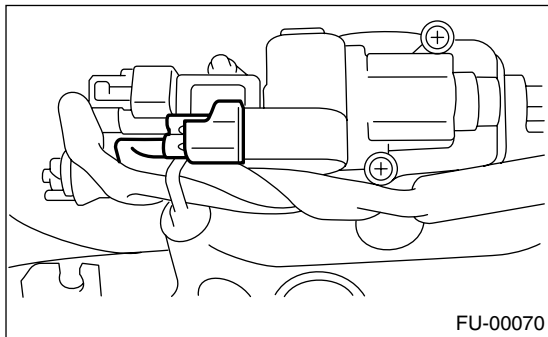

3) Remove the idle air control solenoid valve from throttle body.

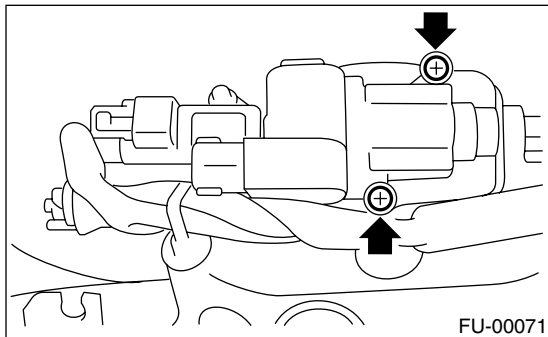

4) Remove the gasket from throttle body.

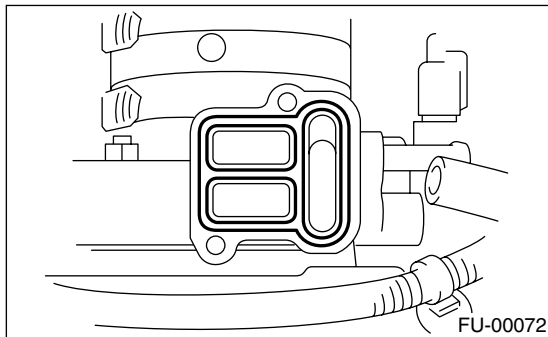

B: INSTALLATION

Install in the reverse order of removal.

NOTE:

Replace the gasket with a new one.

Tightening torque:

2.8 N·m (0.29 kgf·m, 2.1 ft·lb)

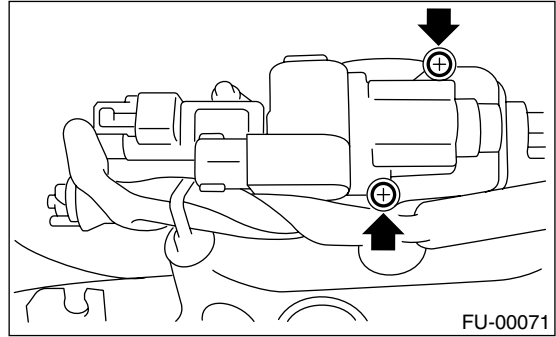

FUEL INJECTOR

FUEL INJECTION (FUEL SYSTEMS)

12. Fuel Injector

A: REMOVAL

1. RH SIDE

- 1) Release the fuel pressure. <Ref. to FU(TURBO)-52, RELEASING OF FUEL PRESSURE, OPERATION, Fuel.>
- 2) Open the fuel filler flap lid and remove fuel filler cap.
- 3) Disconnect the ground cable from battery.

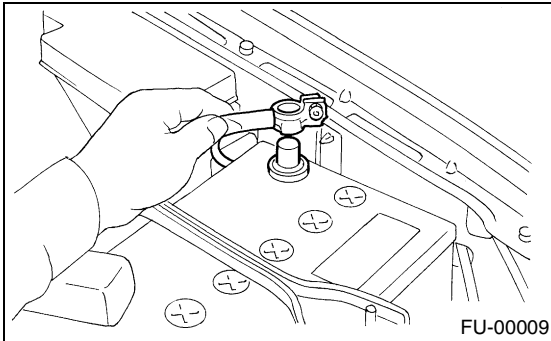

- 4) Remove the intake manifold. <Ref. to FU(TURBO)-14, REMOVAL, Intake Manifold.>
- 5) Remove the fuel pipe protector RH.

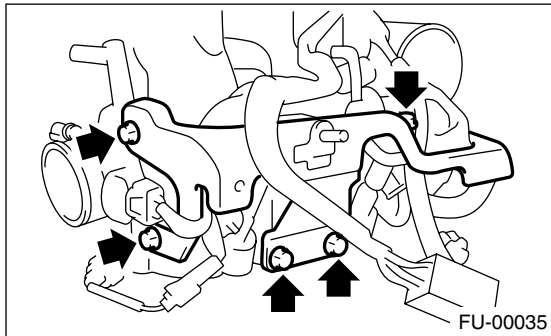

- 6) Disconnect the connector from fuel injector.

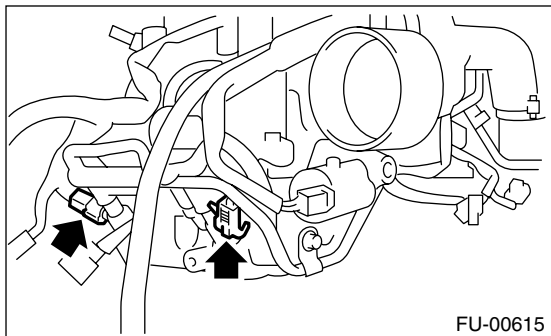

- 7) Remove the bolts which hold injector pipe to intake manifold.

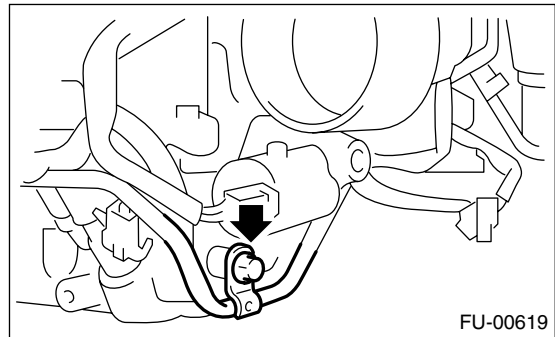
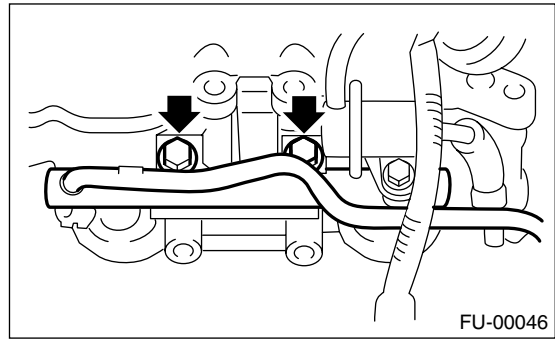

- 8) Remove the fuel injector while lifting up the fuel injector pipe.

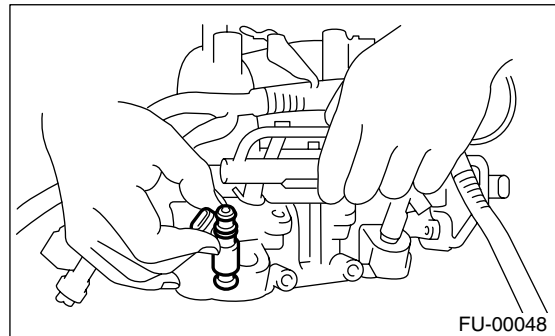

FUEL INJECTOR

FUEL INJECTION (FUEL SYSTEMS)

2. LH SIDE

1) Release the fuel pressure. <Ref. to FU(TURBO)-52, RELEASING OF FUEL PRESSURE, OPERATION, Fuel.>

2) Open the fuel filler flap lid and remove fuel filler cap.

3) Disconnect the ground cable from battery.

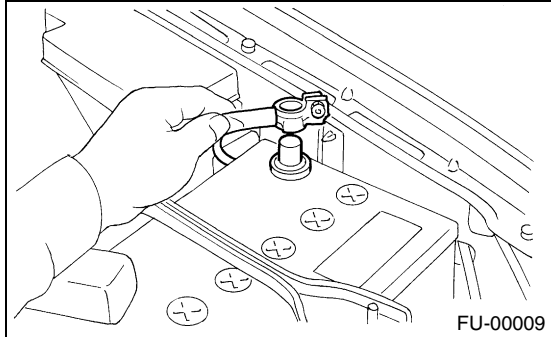

4) Remove the intake manifold. <Ref. to FU(TURBO)-14, REMOVAL, Intake Manifold.>

5) Remove the bolts (A), and then remove the fuel pipe protector LH.

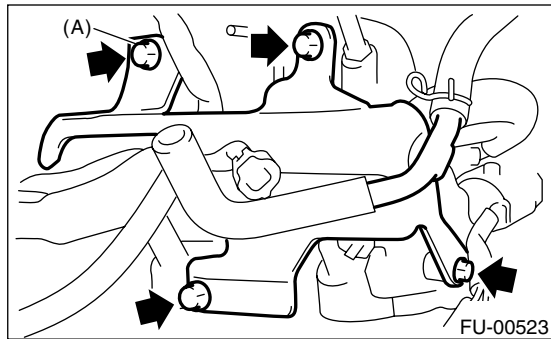

6) Disconnect the connector from fuel injector.

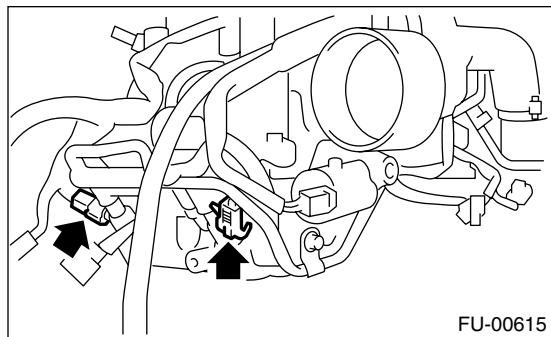

7) Remove the bolts which hold injector pipe to intake manifold.

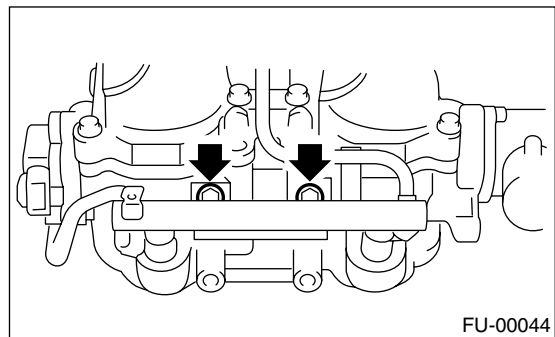
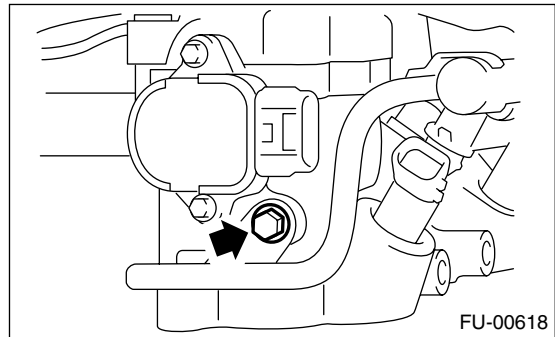
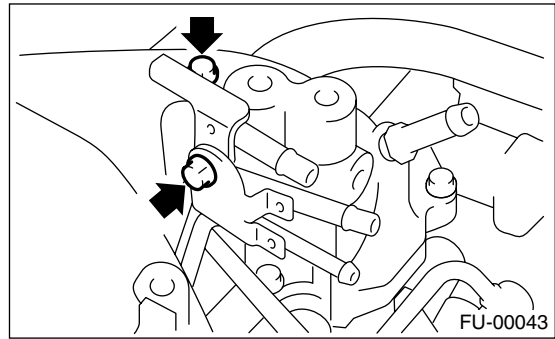

8) Remove the fuel injector while lifting up the fuel injector pipe.

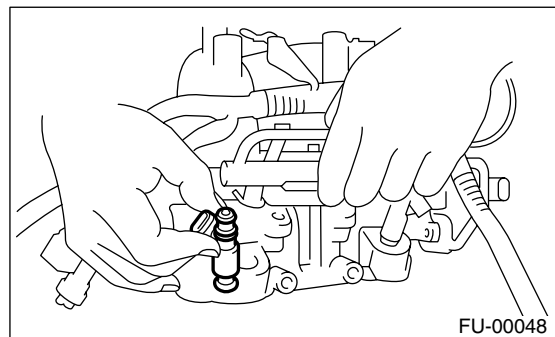

FUEL INJECTOR

FUEL INJECTION (FUEL SYSTEMS)

B: INSTALLATION

1. RH SIDE

Install in the reverse order of removal.

NOTE:

Replace the O-ring and insulators with new ones.

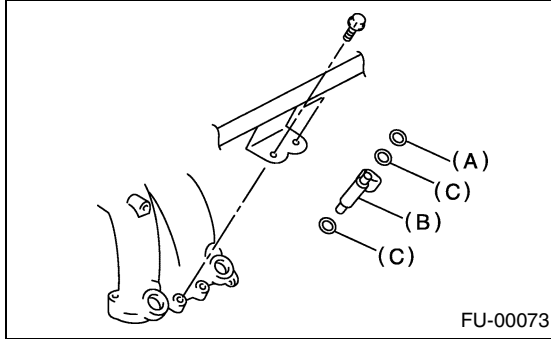

- (A) O-ring
- (B) Fuel injector
- (C) Insulator

Tightening torque:

19 N·m (1.9 kgf·m, 14.0 ft·lb)

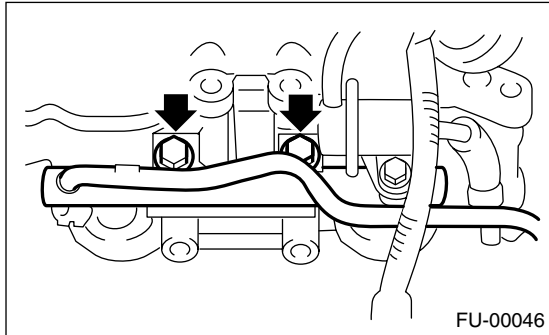

Tightening torque:

19 N·m (1.9 kgf·m, 14.0 ft·lb)

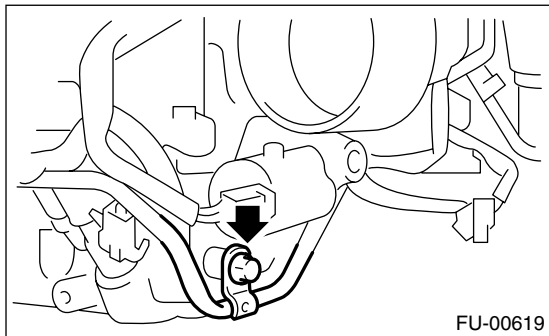

NOTE:

Securely tighten bolt together with ground cable.

Tightening torque:

19 N·m (1.9 kgf·m, 14.0 ft·lb)

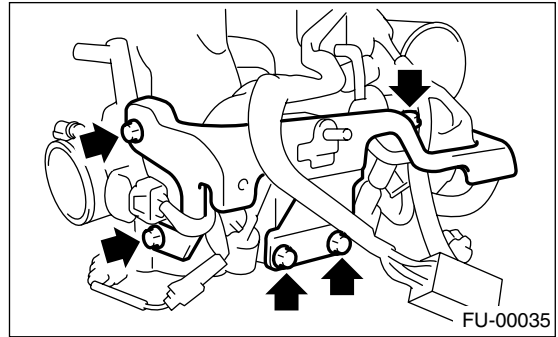

2. LH SIDE

Install in the reverse order of removal.

NOTE:

Replace the O-ring and insulators with new ones.

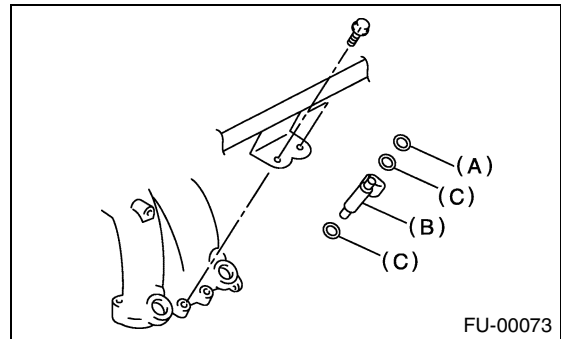

- (A) O-ring
- (B) Fuel injector
- (C) Insulator

Tightening torque:

4.9 N·m (0.5 kgf·m, 3.6 ft·lb)

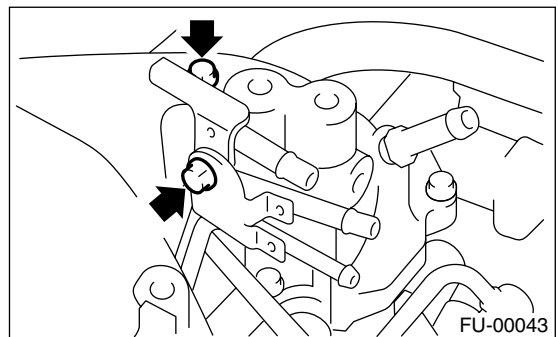

Tightening torque:

19 N·m (1.9 kgf·m, 14.0 ft·lb)

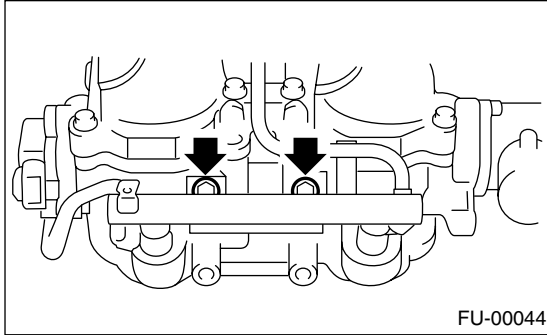

Tightening torque:

19 N·m (1.9 kgf·m, 14.0 ft·lb)

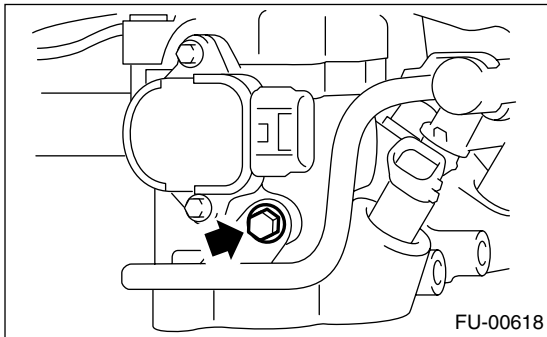

Tightening torque (A):

19 N·m (1.9 kgf·m, 14.0 ft·lb)

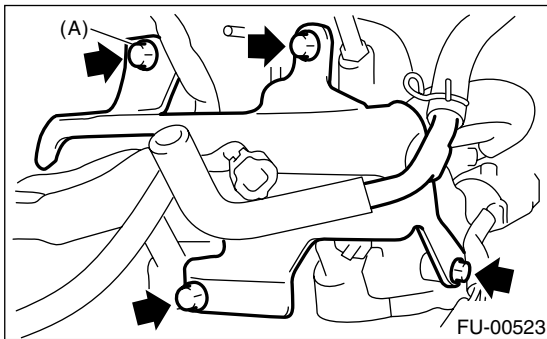

TUMBLE GENERATOR VALVE ASSEMBLY

FUEL INJECTION (FUEL SYSTEMS)

13. Tumble Generator Valve Assembly

A: REMOVAL

- 1) Release the fuel pressure. <Ref. to FU(TURBO)-52, RELEASING OF FUEL PRESSURE, OPERATION, Fuel.>
- 2) Open the fuel filler flap lid and remove fuel filler cap.
- 3) Disconnect the ground cable from battery.

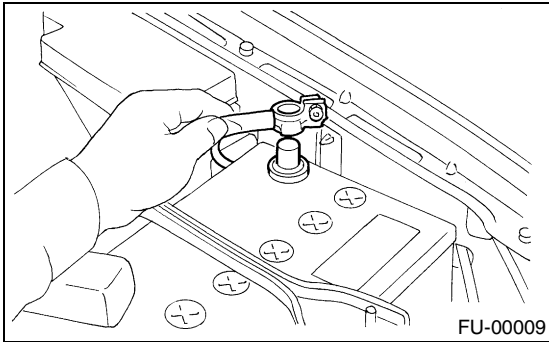

- 4) Remove the intake manifold. <Ref. to FU(TURBO)-14, REMOVAL, Intake Manifold.>
- 5) Disconnect the connector from tumble generator valve sensor.

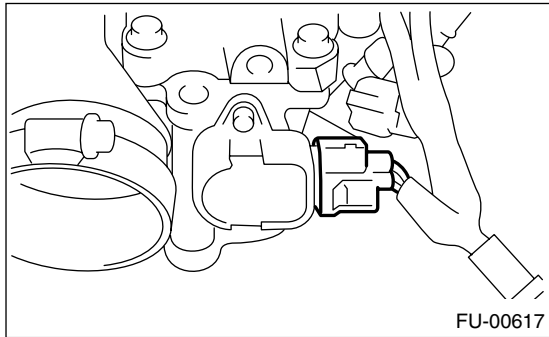

- 6) Disconnect the connector from tumble generator valve actuator.

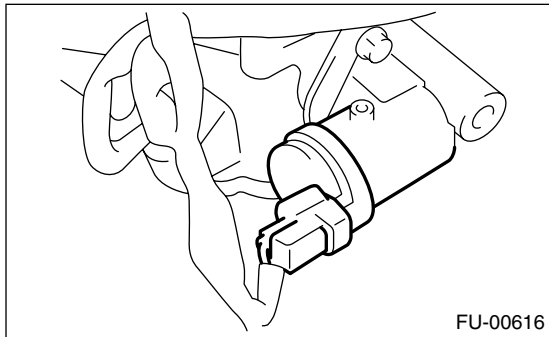

- 7) Remove the fuel injector. <Ref. to FU(TURBO)-36, REMOVAL, Fuel Injector.>

- 8) Remove the tumble generator valve body from intake manifold.

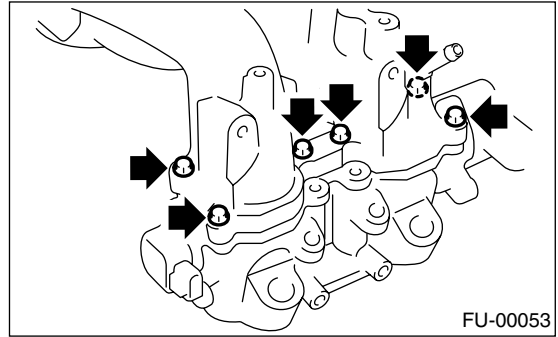

B: INSTALLATION

Install in the reverse order of removal.

NOTE:

Always use new gaskets.

Tightening torque:

8.25 N·m (0.84 kgf·m, 6.1 ft·lb)

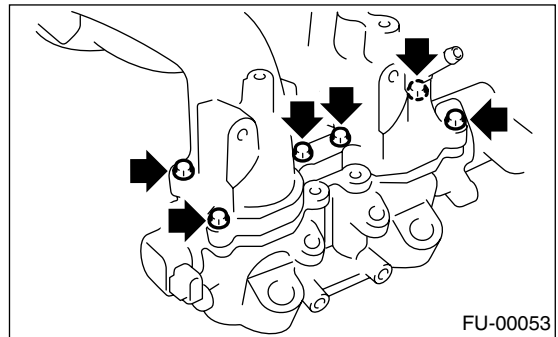

TUMBLE GENERATOR VALVE ACTUATOR

FUEL INJECTION (FUEL SYSTEMS)

14. Tumble Generator Valve Actuator

A: REMOVAL

1. RH SIDE

- 1) Release the fuel pressure. <Ref. to FU(TURBO)-52, RELEASING OF FUEL PRESSURE, OPERATION, Fuel.>
- 2) Open the fuel filler flap lid and remove fuel filler cap.
- 3) Disconnect the ground cable from battery.

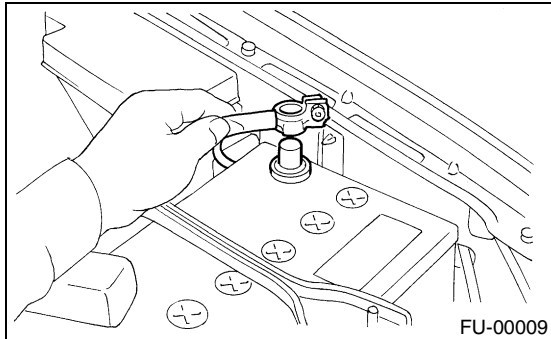

- 4) Remove the intake manifold. <Ref. to FU(TURBO)-14, REMOVAL, Intake Manifold.>
- 5) Disconnect the connector from tumble generator valve actuator RH.
- 6) Remove the tumble generator valve RH.

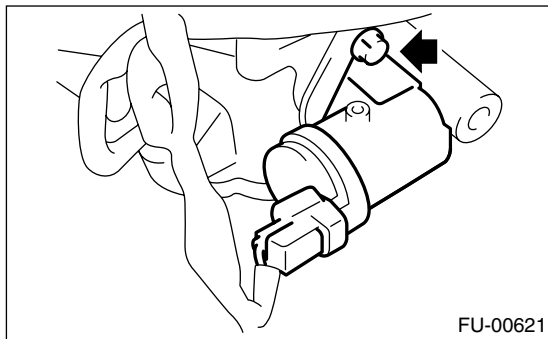

2. LH SIDE

- 1) Disconnect the ground cable from battery.

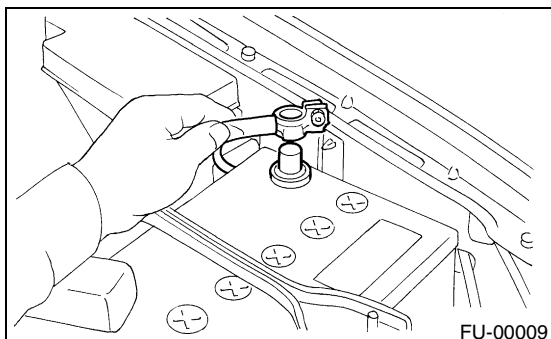

- 2) Disconnect the connector from tumble generator valve LH.

- 3) Remove the tumble generator valve actuator LH.

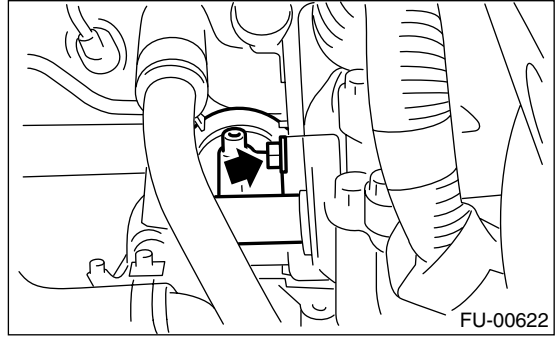

B: INSTALLATION

1. RH SIDE

Install in the reverse order of removal.

2. LH SIDE

Install in the reverse order of removal.