

11.Preparation for Overhaul

A: PROCEDURE

1) After removing the engine from body, secure it in the ST shown below.

ST1	498457000	ENGINE STAND ADAPTER RH
ST2	498457100	ENGINE STAND ADAPTER LH
ST3	499817000	ENGINE STAND

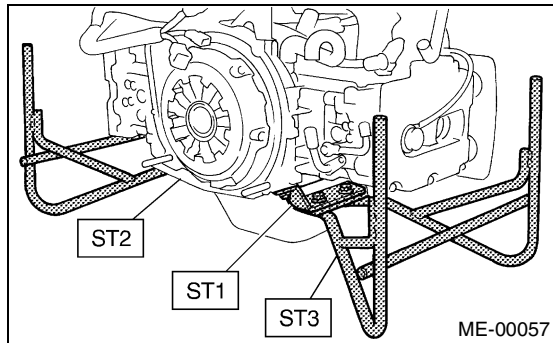

2) In this section the procedures described under each index are all connected and stated in order. It will be the complete procedure for overhauling of the engine itself when you go through all steps in the process.

Therefore, in this section, to conduct the particular procedure within the flow of a section, you need to go back and conduct the procedure described previously in order to do that particular procedure.

V-BELT

MECHANICAL

12.V-belt

A: REMOVAL

1. FRONT SIDE BELT

NOTE:

Perform the following procedures 1) to 4) with the engine installed to body.

1) Remove the V-belt cover.

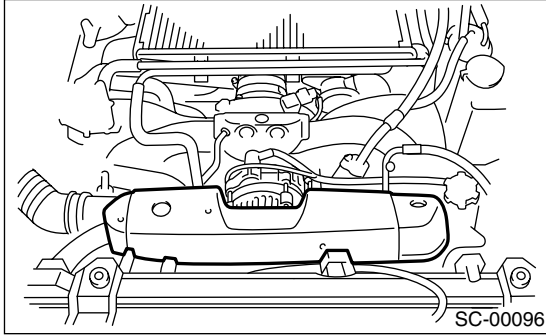

- 2) Loosen the lock bolt (A).
- 3) Loosen the slider bolt (B).
- 4) Remove the front side belt (C).

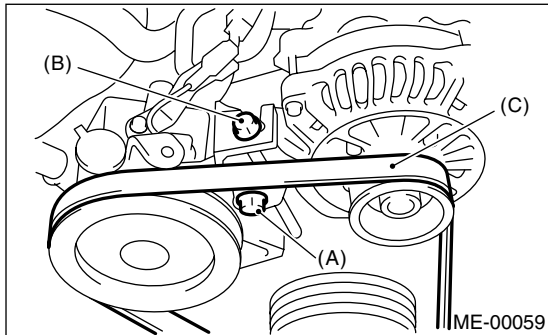

2. REAR SIDE BELT

- 1) Loosen the lock nut (A).
- 2) Loosen the slider bolt (B).

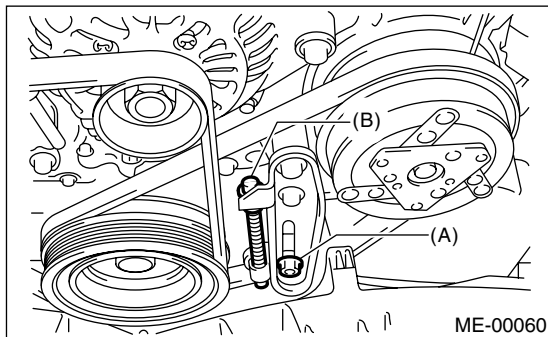

3) Remove the A/C belt.

4) Remove the A/C belt tensioner.

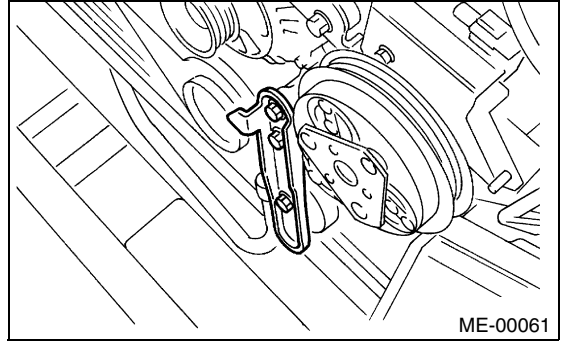

B: INSTALLATION

1. FRONT SIDE BELT

CAUTION:

Wipe off any oil or water on the belt and pulley.

- 1) Install the belt (C), and tighten the slider bolt so as to obtain the specified belt tension <Ref. to ME(TURBO)-45, INSPECTION, V-belt.>
- 2) Tighten the lock bolt (A)
- 3) Tighten the slider bolt (B).

Tightening torque:

Lock bolt through bolt:

25 N·m (2.5 kgf-m, 18.1 ft-lb)

Slider bolt:

8 N·m (0.8 kgf-m, 5.5 ft-lb)

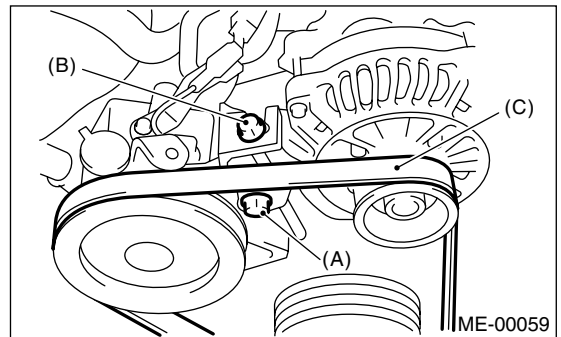

2. REAR SIDE BELT

- 1) Install the belt, and tighten the slider bolt (B) so as to obtain the specified belt tension. <Ref. to ME(TURBO)-45, INSPECTION, V-belt.>
- 2) Tighten the lock nut (A).

Tightening torque:

Lock nut (A);

22.6 N·m (2.3 kgf·m, 16.6 ft·lb)

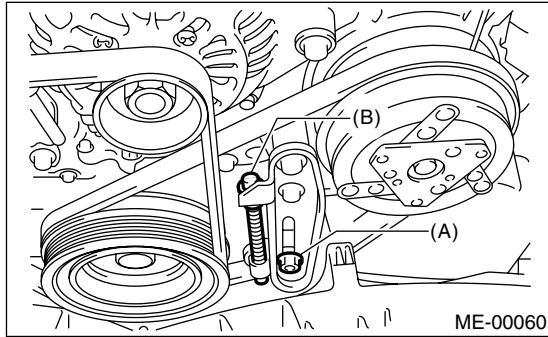

C: INSPECTION

- 1) Replace the belts, if cracks, fraying or wear is found.
- 2) Check the drive belt tension and adjust it if necessary by changing generator installing position and/or idler pulley installing position.

Belt tension

(A)

replaced: 7 — 9 mm (0.276 — 0.354 in)

reused: 9 — 11 mm (0.354 — 0.433 in)

(B)*

replaced: 7.5 — 8.5 mm (0.295 — 0.335 in)

reused: 9.0 — 10.0 mm (0.354 — 0.394 in)

***: with air conditioner**

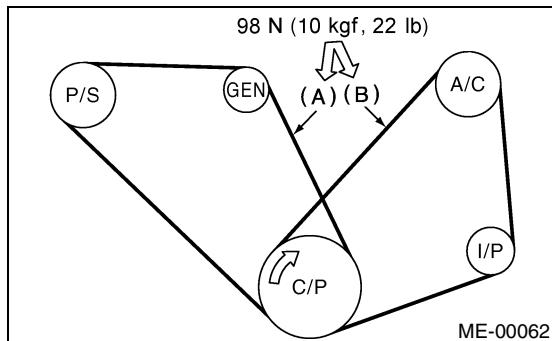

- C/P Crankshaft pulley
- GEN Generator
- P/S Power steering oil pump pulley
- A/C Air conditioning compressor pulley
- I/P Idler pulley

CRANKSHAFT PULLEY

MECHANICAL

13. Crankshaft Pulley

A: REMOVAL

1) Remove the V-belt. <Ref. to ME(TURBO)-44, REMOVAL, V-belt.>

2) Remove the crankshaft pulley bolt. To lock the crankshaft, use ST.

ST 499977400 CRANKSHAFT PULLEY WRENCH

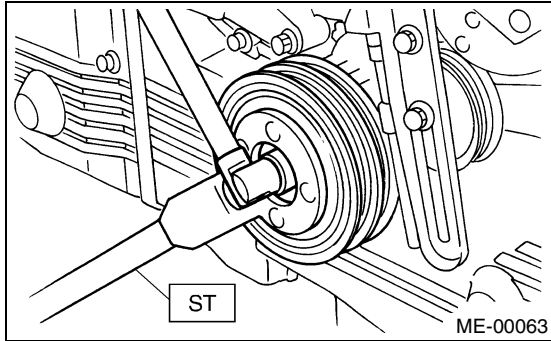

3) Remove the crankshaft pulley.

B: INSTALLATION

1) Install the crankshaft pulley.

2) Install the pulley bolt.

To lock the crankshaft, use ST.

ST 499977400 CRANKSHAFT PULLEY WRENCH

(1) Clean the crankshaft pulley thread using an air gun.

(2) Apply engine oil to the crankshaft pulley bolt seat and thread.

(3) Tighten the bolts temporarily with tightening torque of 44 N·m (4.5 kgf·m, 33 ft·lb).

(4) Tighten the crankshaft pulley bolts.

Tightening torque:

127 N·m (13 kgf·m, 94.0 ft·lb)

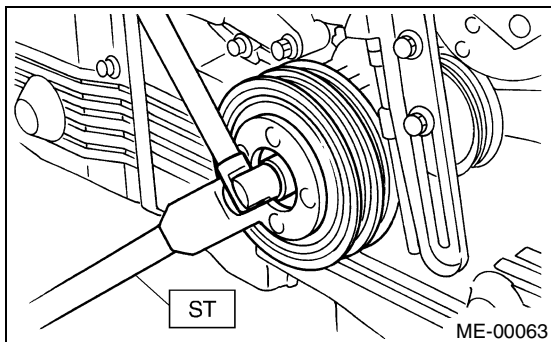

3) Confirm that the tightening angle of crankshaft pulley bolt is 45 degrees or more. If not, conduct the following procedures (1) through (4).

CAUTION:

If the tightening angle of crankshaft pulley bolt is less than 45 degrees, the bolt should be damaged. In this case, the bolt must be replaced.

(1) Replace the crankshaft pulley bolts and clean them.

Crankshaft pulley bolt:
12369AA011

(2) Clean the crankshaft thread using an air gun.

(3) Tighten the bolts temporarily with tightening torque of 44 N·m (4.5 kgf·m, 33 ft·lb).

(4) Tighten the crankshaft pulley bolts keeping them in an angle between 45 degrees and 60 degrees.

NOTE:

Conduct the tightening procedures by confirming the turning angle of the crankshaft pulley bolt referring to the gauge indicated on the belt cover.

4) Install the A/C belt tensioner.

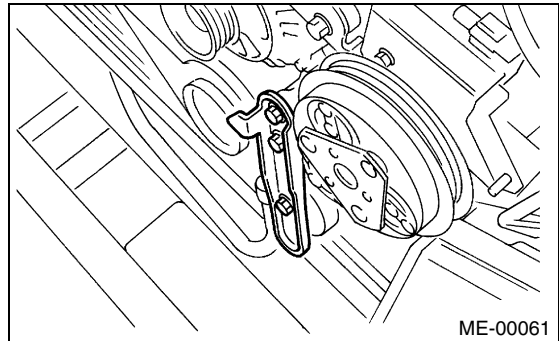

5) Install the V-belt. <Ref. to ME(TURBO)-44, INSTALLATION, V-belt.>

C: INSPECTION

1) Make sure the V-belt is not worn or otherwise damaged.

2) Check the tension of the belt. <Ref. to ME(TURBO)-45, INSPECTION, V-belt.>

14. Belt Cover

A: REMOVAL

- 1) Remove the V-belt. <Ref. to ME(TURBO)-44, REMOVAL, V-belt.>
- 2) Remove the crankshaft pulley. <Ref. to ME(TURBO)-46, REMOVAL, Crankshaft Pulley.>
- 3) Remove the belt cover (LH) (A).
- 4) Remove the belt cover (RH) (B).
- 5) Remove the front belt cover (C).

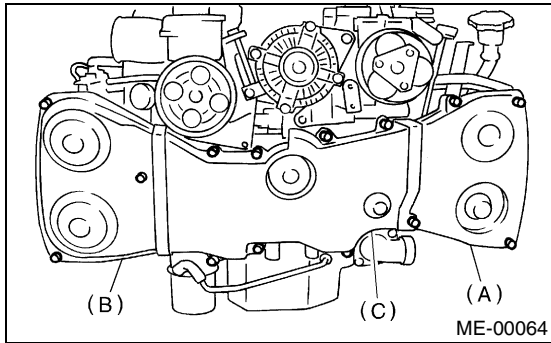

B: INSTALLATION

- 1) Install the front belt cover (C).

Tightening torque:

5 N·m (0.5 kgf·m, 3.6 ft·lb)

- 2) Install the belt cover (RH) (B).

Tightening torque:

5 N·m (0.5 kgf·m, 3.6 ft·lb)

- 3) Install the belt cover (LH) (A).

Tightening torque:

5 N·m (0.5 kgf·m, 3.6 ft·lb)

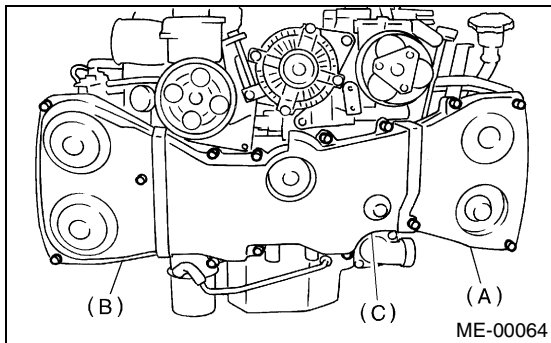

- 4) Install the crankshaft pulley. <Ref. to ME(TURBO)-46, INSTALLATION, Crankshaft Pulley.>
- 5) Install the V-belt. <Ref. to ME(TURBO)-44, INSTALLATION, V-belt.>

C: INSPECTION

Make sure the cover is not damaged.

TIMING BELT ASSEMBLY

MECHANICAL

15. Timing Belt Assembly

A: REMOVAL

1. TIMING BELT

- 1) Remove the V-belt. <Ref. to ME(TURBO)-44, REMOVAL, V-belt.>
- 2) Remove the crankshaft pulley. <Ref. to ME(TURBO)-46, REMOVAL, Crankshaft Pulley.>
- 3) Remove the belt cover. <Ref. to ME(TURBO)-47, REMOVAL, Belt Cover.>
- 4) Remove the timing belt guides. (MT vehicles)

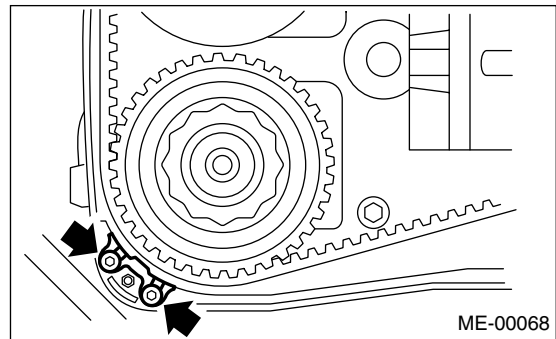
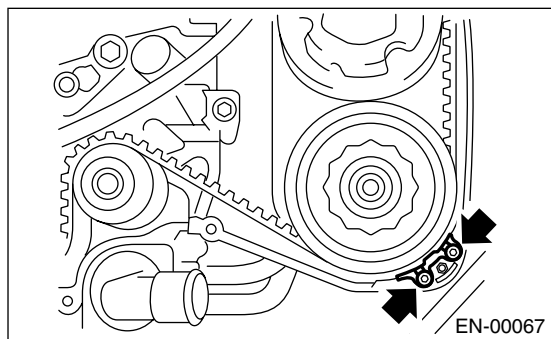
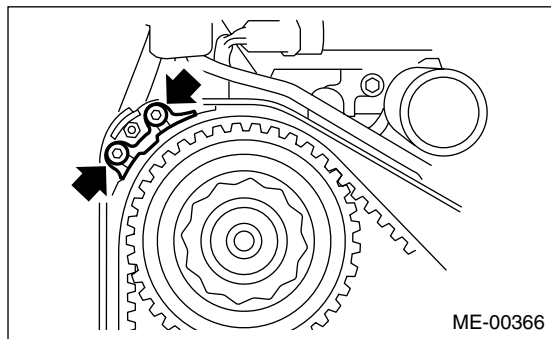
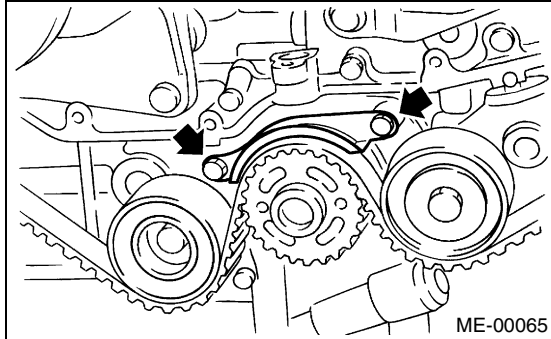

5) If the alignment mark and/or arrow mark (which indicates rotation direction) on timing belt fade away, put new marks before removing the timing belt as follows:

- (1) Turn the crankshaft using ST, and align the alignment marks on crankshaft sprocket, intake camshaft sprocket (LH), exhaust camshaft sprocket (LH), intake camshaft sprocket (RH) and exhaust camshaft sprocket (RH) with notches of belt cover and cylinder block.

ST 499987500 CRANKSHAFT SOCKET

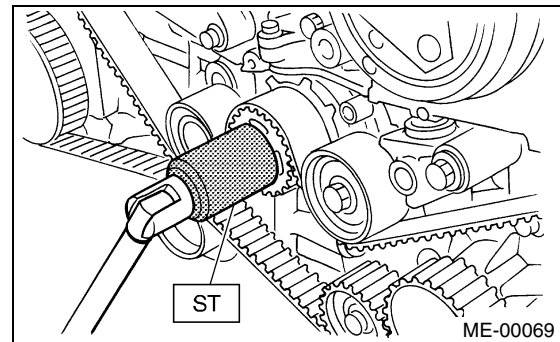

(2) Using white paint, put alignment and/or arrow marks on the timing belts in relation to the sprockets.

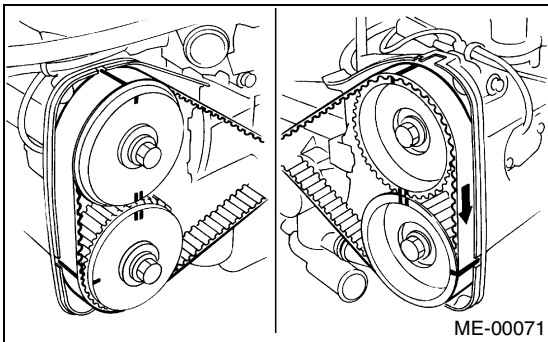
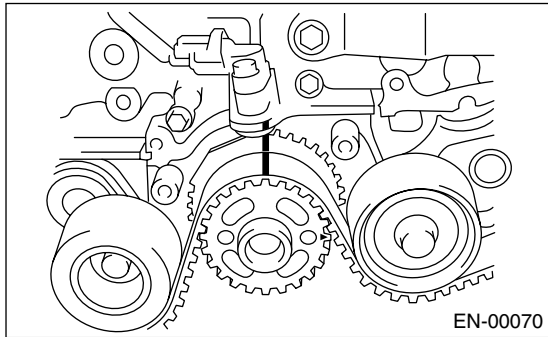

Z₁: 54.5 tooth length
Z₂: 51 tooth length
Z₃: 28 tooth length

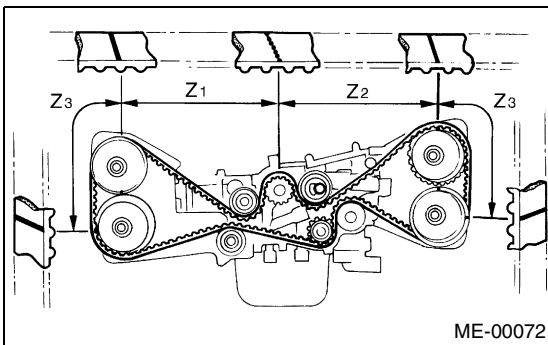

6) Remove the belt idler (A).

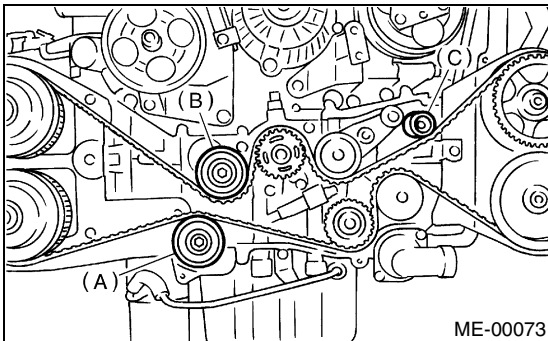

7) Remove the timing belt.

CAUTION:

After the timing belt has been removed, never rotate the intake and exhaust, camshaft sprocket. If the camshaft sprocket is rotated, the intake and exhaust valve heads strike together and valve stems are bent.

2. BELT IDLER AND AUTOMATIC BELT TENSION ADJUSTER ASSEMBLY

1) Remove the belt idler (B) and (C).

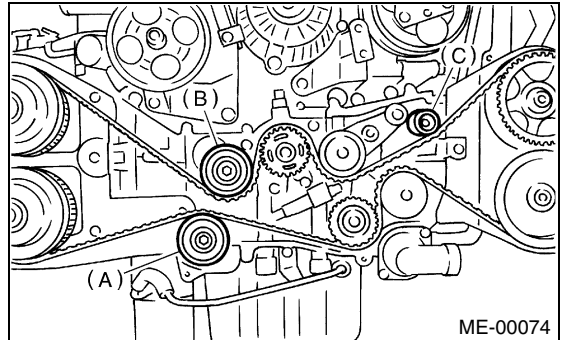

2) Remove the belt idler No. 2.

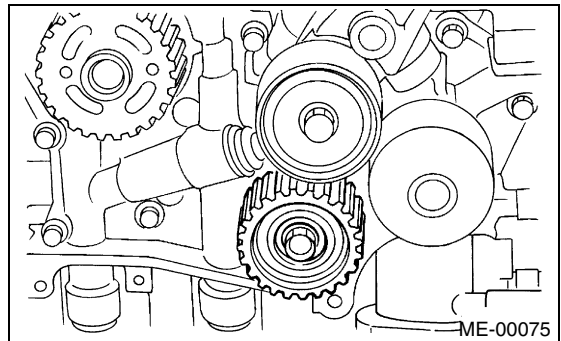

3) Remove the automatic belt tension adjuster assembly.

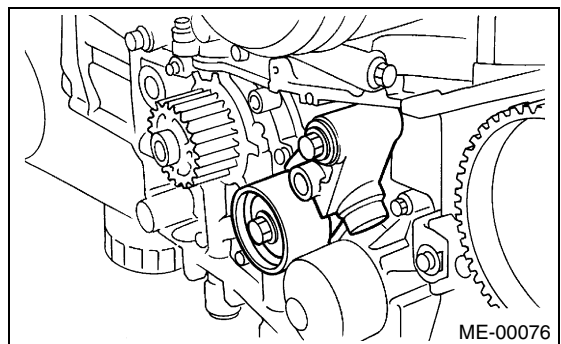

TIMING BELT ASSEMBLY

MECHANICAL

B: INSTALLATION

1. AUTOMATIC BELT TENSION ADJUST-ER ASSEMBLY AND BELT IDLER

1) Preparation for installation of automatic belt tension adjuster assembly:

NOTE:

- Always use a vertical type pressing tool to move the adjuster rod down.
- Do not use a lateral type vise.
- Push the adjuster rod vertically.
- Be sure to slowly move the adjuster rod down applying a pressure of 294 N (30 kgf, 66 lb).
- Press-in the push adjuster rod gradually taking more than 3 minutes.
- Do not allow press pressure to exceed 9,807 N (1,000 kgf, 2,205 lb).
- Press the adjuster rod as far as the end surface of cylinder. Do not press the adjuster rod into the cylinder. Doing so may damage the cylinder.
- Do not release the press pressure until stopper pin is completely inserted.

(1) Attach the automatic belt tension adjuster assembly to the vertical pressing tool.

(2) Slowly move the adjuster rod down with a pressure of 294 N (30 kgf, 66 lb) until the adjuster rod is aligned with the stopper pin hole in the cylinder.

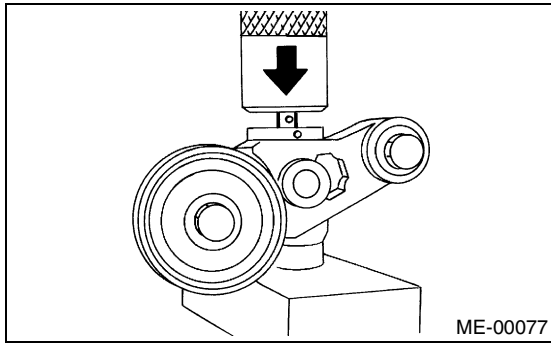

(3) With a 2 mm (0.08 in) dia. stopper pin or a 2 mm (0.08 in) (nominal) dia. hex bar wrench inserted into the stopper pin hole in the cylinder, secure the adjuster rod.

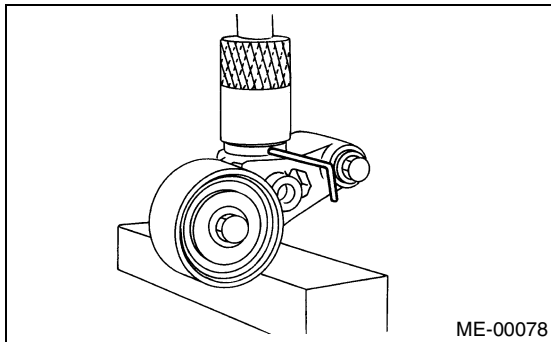

2) Install the automatic belt tension adjuster assembly.

Tightening torque:

39 N·m (4.0 kgf·m, 28.9 ft·lb)

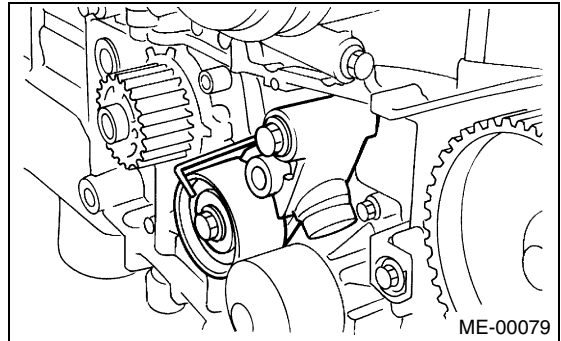

3) Install the belt idler No. 2.

Tightening torque:

39 N·m (4.0 kgf·m, 28.9 ft·lb)

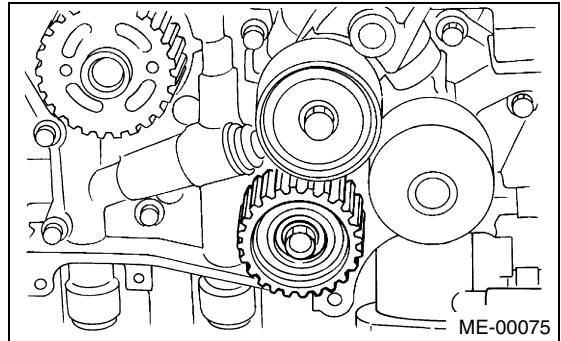

4) Install the belt idler.

Tightening torque:

39 N·m (4.0 kgf·m, 28.9 ft·lb)

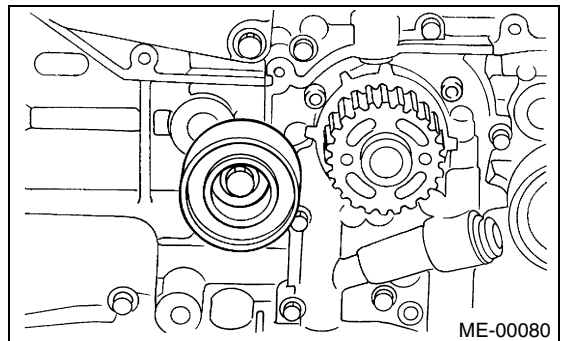

2. TIMING BELT

1) Preparation for installation of automatic belt tension adjuster assembly. <Ref. to ME(TURBO)-50, AUTOMATIC BELT TENSION ADJUSTER ASSEMBLY AND BELT IDLER, Timing Belt Assembly.>

2) Crankshaft and camshaft sprocket alignment.

(1) Align mark (A) on the crankshaft sprocket with mark on the oil pump cover at cylinder block.

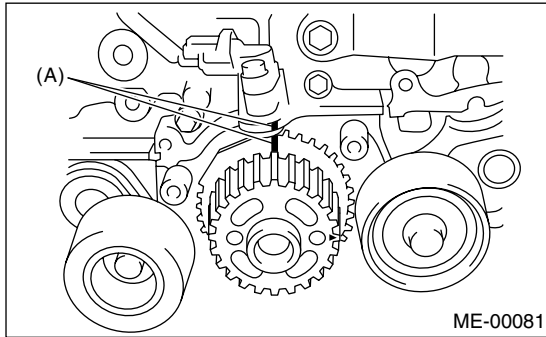

(2) Align single line mark (A) on the exhaust camshaft sprocket (RH) with notch (B) on belt cover.

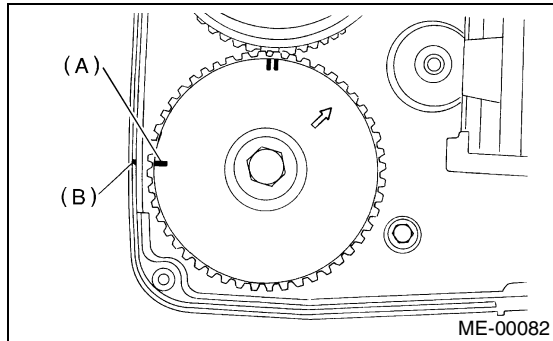

(3) Align single line mark (A) on the intake camshaft sprocket (RH) with notch (B) on belt cover. (Make sure double lines (C) on intake camshaft and exhaust camshaft sprockets are aligned.)

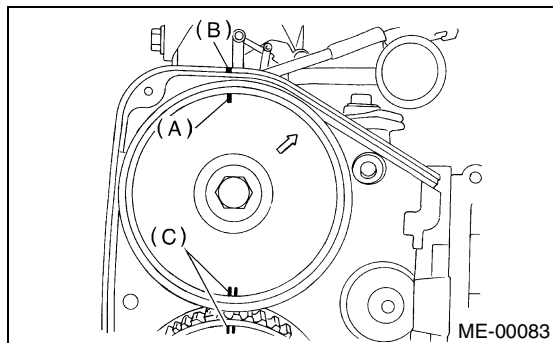

(4) Align single line mark (A) on exhaust camshaft sprocket (LH) with notch (B) on belt cover by turning the sprocket counterclockwise (as viewed from front of engine).

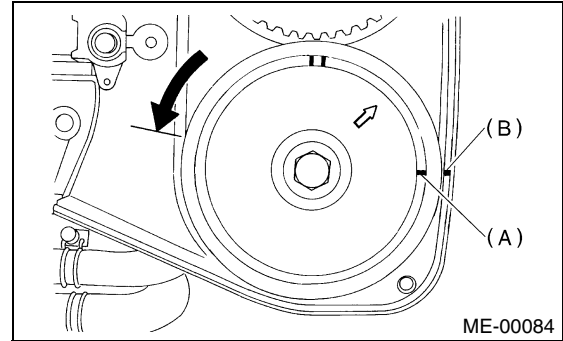

(5) Align the single line mark (A) on intake camshaft sprocket (LH) with notch (B) on belt cover by turning the sprocket clockwise (as viewed from front of engine).

Ensure the double lines (C) on intake and exhaust camshaft sprockets are aligned.

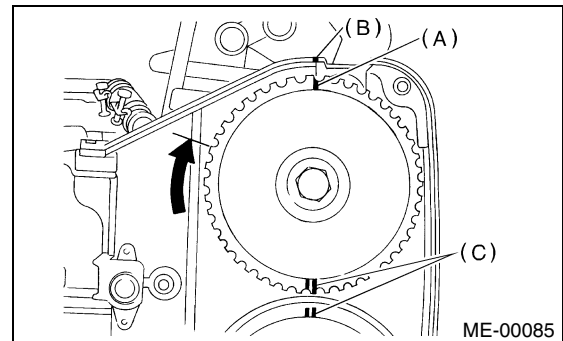

TIMING BELT ASSEMBLY

MECHANICAL

- (6) Ensure the camshaft and crankshaft sprockets are positioned properly.

CAUTION:

• Intake and exhaust camshafts for this DOHC engine can be independently rotated with the timing belts removed. As can be seen from the figure, if the intake and exhaust valves are lifted simultaneously, their heads will interfere with each other, resulting in bent valves.

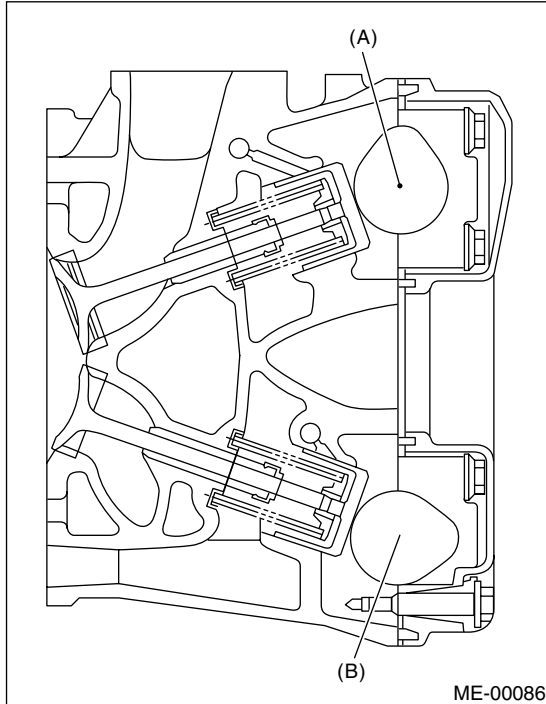

- (A) Intake camshaft
(B) Exhaust camshaft

- When the timing belts are not installed, four camshafts are held at the “zero-lift” position, where all cams on camshafts do not push the intake and exhaust valves down. (Under this condition, all valves remain unlifted.)
- When the camshafts are rotated to install the timing belts, #2 intake and #4 exhaust cam of left-hand camshafts are held to push their corresponding valves down. (Under this condition, these valves are held lifted.) Right-side camshafts are held so that their cams do not push valves down.
- Left-hand camshafts must be rotated from the “zero-lift” position to the position where the timing belt is to be installed at as small an angle as possible, in order to prevent mutual interference of intake and exhaust valve heads.

- Do not allow the camshafts to rotate in the direction shown in the figure as this causes both intake and exhaust valves to lift simultaneously, resulting in interference with their heads.

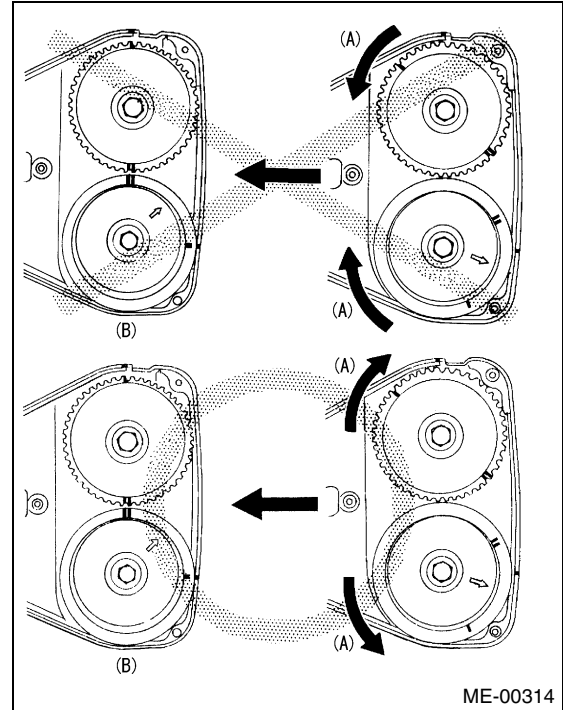

- (A) Rotating direction
(B) Timing belt installation position

3) Installation of timing belt:

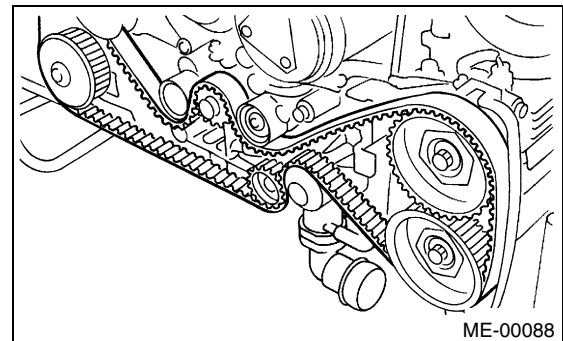

TIMING BELT ASSEMBLY

MECHANICAL

Align the alignment mark on timing belt with marks on sprockets in alphabetical order shown in the figure. While aligning marks, position the timing belt properly.

CAUTION:

- Disengagement of more than three timing belt teeth may result in interference between the valve and piston.
- Ensure the belt's rotating direction is correct.

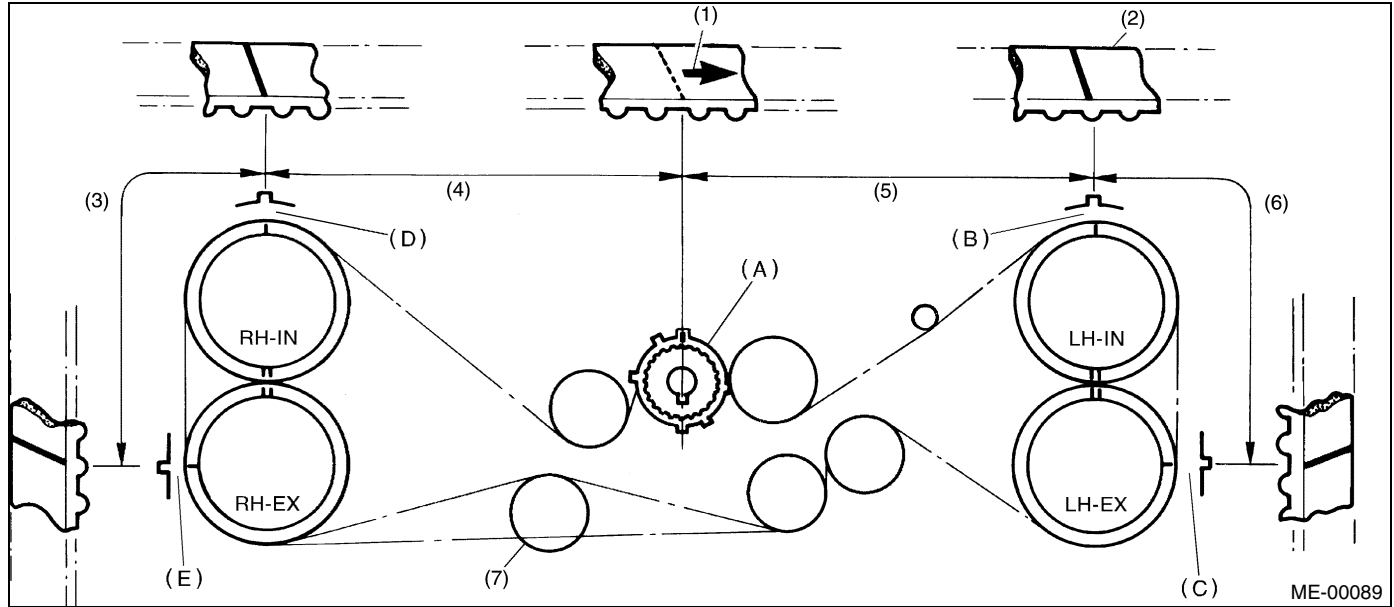

- | | | |
|---------------------|-----------------------|---------------------------|
| (1) Arrow mark | (4) 54.5 tooth length | (7) Install it in the end |
| (2) Timing belt | (5) 51 tooth length | |
| (3) 28 tooth length | (6) 28 tooth length | |

4) Install the belt idlers.

Tightening torque:

39 N·m (4.0 kgf·m, 28.9 ft·lb)

NOTE:

Make sure that the marks on the timing belt and sprockets are aligned.

Clearance:

1.0±0.5 mm (0.039±0.020 in)

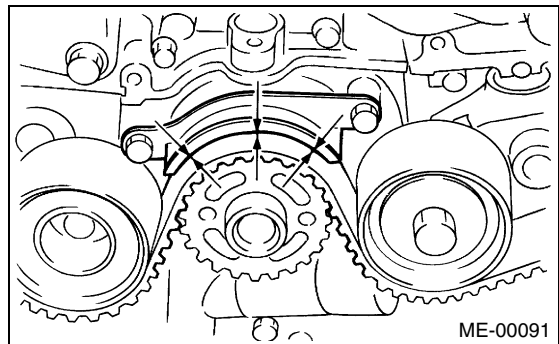
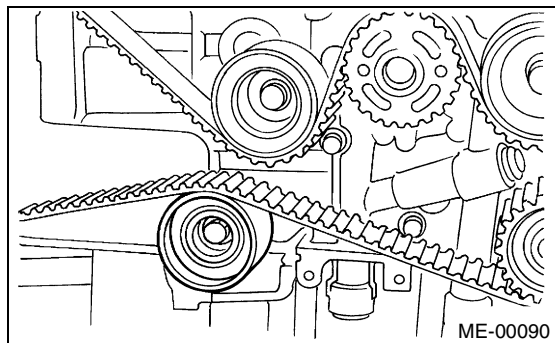

5) After ensuring that the marks on the timing belt and sprockets are aligned, remove the stopper pin from tensioner adjuster.

6) Install the timing belt guide. (MT vehicles)

- (1) Temporarily tighten the bolts.
- (2) Check and adjust the clearance between timing belt and timing belt guide.

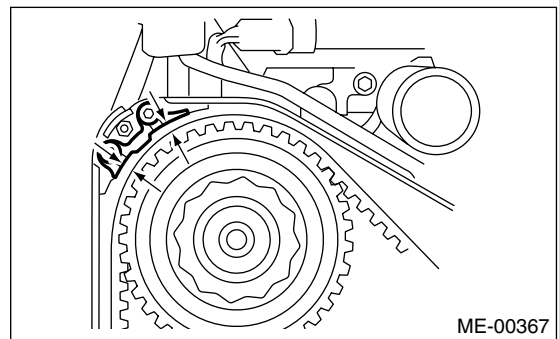

TIMING BELT ASSEMBLY

MECHANICAL

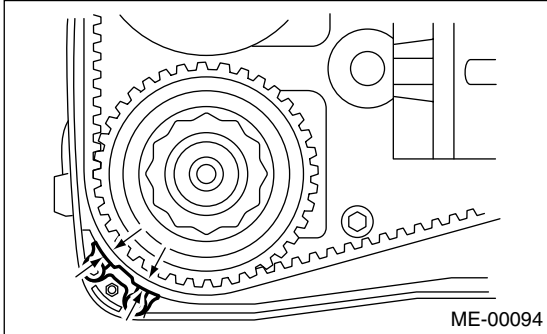
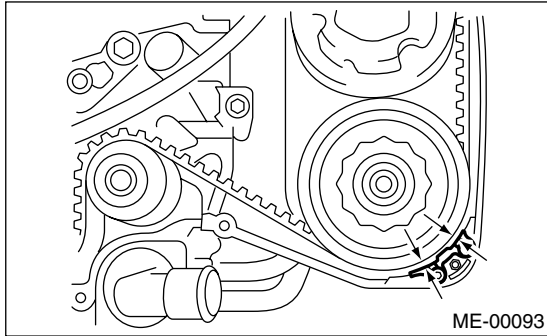

(3) Tighten the bolts.

Tightening torque:
10 N·m (1.0 kgf·m, 7.2 ft·lb)

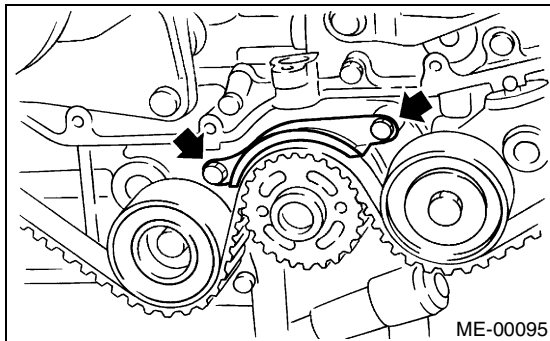

Tightening torque:
6.4 N·m (0.7 kgf·m, 5.1 ft·lb)

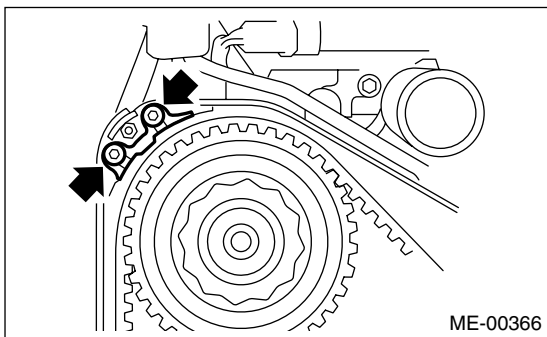

Tightening torque:
6.4 N·m (0.7 kgf·m, 5.1 ft·lb)

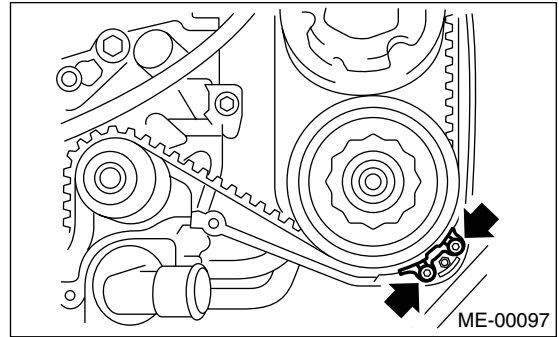

Tightening torque:
6.4 N·m (0.7 kgf·m, 5.1 ft·lb)

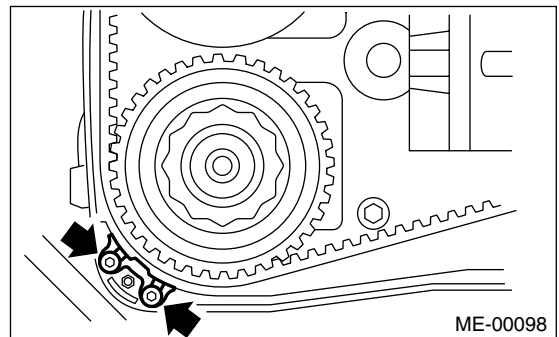

- 7) Install the belt cover. <Ref. to ME(TURBO)-47, INSTALLATION, Belt Cover.>
- 8) Install the crankshaft pulley. <Ref. to ME(TURBO)-46, INSTALLATION, Crankshaft Pulley.>
- 9) Install the V-belt. <Ref. to ME(TURBO)-44, INSTALLATION, V-belt.>

C: INSPECTION

1. TIMING BELT

- 1) Check the timing belt teeth for breaks, cracks, and wear. If any fault is found, replace the belt.
- 2) Check the condition of back side of belt; if any crack is found, replace the belt.

NOTE:

- Be careful not to let oil, grease or coolant contact the belt. Remove quickly and thoroughly if this happens.
- Do not bend the belt sharply.

Bending radius: *h*

60 mm (2.36 in) or more

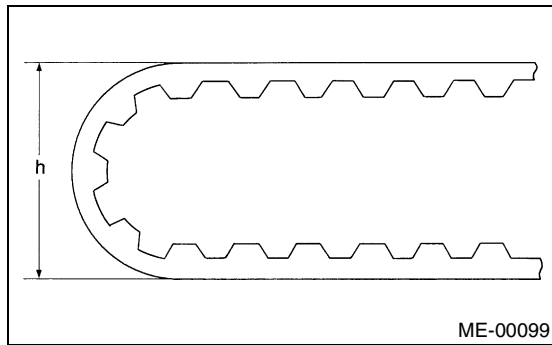

2. AUTOMATIC BELT TENSION ADJUST-ER

- 1) Visually check the oil seals for leaks, and rod ends for abnormal wear or scratches. If necessary, replace the automatic belt tension adjuster assembly.

NOTE:

Slight traces of oil at rod's oil seal does not indicate a problem.

- 2) Check that the adjuster rod does not move when a pressure of 294 N (30 kgf, 66 lb) is applied to it. This is to check adjuster rod stiffness.

- 3) If the adjuster rod is not stiff and moves freely when applying 294 N (30 kgf, 66 lb), check it using the following procedures:

- (1) Slowly press the adjuster rod down to the end surface of the cylinder. Repeat this motion 2 or 3 times.
- (2) With the adjuster rod moved all the way up, apply a pressure of 294 N (30 kgf, 66 lb) to it. Check the adjuster rod stiffness.
- (3) If the the adjuster rod is not stiff and moves down, replace the automatic belt tension adjuster assembly with a new one.

NOTE:

- Always use a vertical type pressing tool to move the adjuster rod down.
 - Do not use a lateral type vise.
 - Push the adjuster rod vertically.
 - Press-in the push adjuster rod gradually taking more than 3 minutes.
 - Do not allow press pressure to exceed 9,807 N (1,000 kgf, 2,205 lb).
 - Press the adjuster rod as far as the end surface of the cylinder. Do not press the adjuster rod into the cylinder. Doing so may damage the cylinder.
- 4) Measure the extension of rod beyond the body. If it is not within specifications, replace with a new one.

Rod extension: *H*

5.7±0.5 mm (0.224±0.020 in)

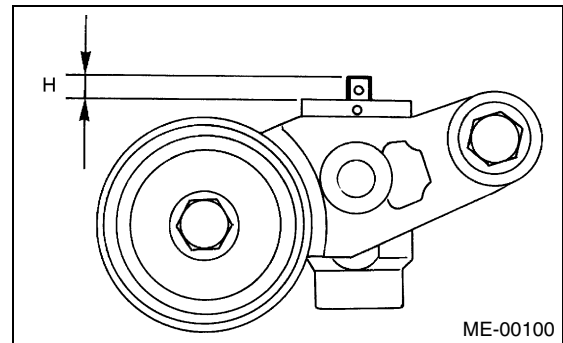

3. BELT TENSION PULLEY

- 1) Check the mating surfaces of timing belt and contact point of adjuster rod for abnormal wear or scratches. Replace the belt tension pulley if faulty.
- 2) Check the belt tension pulley for smooth rotation. Replace if noise or excessive play is noted.
- 3) Check the belt tension pulley for grease leakage.

4. BELT IDLER

- 1) Check the idler for smooth rotation. Replace if noise or excessive play is noted.
- 2) Check the outer contacting surfaces of idler pulley for abnormal wear and scratches.
- 3) Check the idler for grease leakage.

CAMSHAFT SPROCKET

MECHANICAL

16. Camshaft Sprocket

A: REMOVAL

- 1) Remove the V-belt. <Ref. to ME(TURBO)-44, REMOVAL, V-belt.>
- 2) Remove the crankshaft pulley. <Ref. to ME(TURBO)-46, REMOVAL, Crankshaft Pulley.>
- 3) Remove the belt cover. <Ref. to ME(TURBO)-47, REMOVAL, Belt Cover.>
- 4) Remove the timing belt assembly. <Ref. to ME(TURBO)-48, REMOVAL, Timing Belt Assembly.>
- 5) Remove the camshaft position sensor. <Ref. to FU(TURBO)-30, REMOVAL, Camshaft Position Sensor.>
- 6) Remove the camshaft sprockets. To lock the camshaft, use ST.

ST 18231AA010	CAMSHAFT SPROCKET WRENCH (INTAKE LH)
ST 499207400	CAMSHAFT SPROCKET WRENCH (Except INTAKE LH)

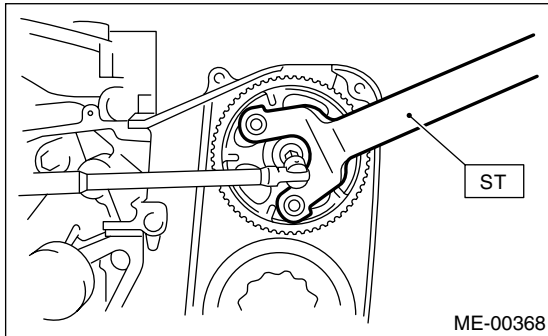

B: INSTALLATION

- 1) Install the camshaft sprocket. To lock the camshaft, use ST.

ST 18231AA010	CAMSHAFT SPROCKET WRENCH (INTAKE LH)
ST 499207400	CAMSHAFT SPROCKET WRENCH (Except INTAKE LH)

Tightening torque:

98 N·m (10 kgf·m, 72.4 ft·lb)

NOTE:

Do not confuse the right and left side camshaft sprockets intake side during installation. The camshaft sprocket LH is identified by a projection used to monitor camshaft position sensor.

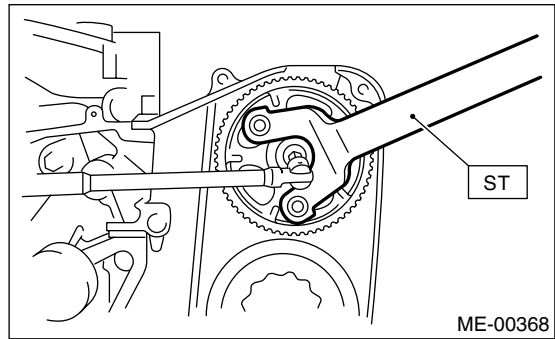

- 2) Install the camshaft position sensor. <Ref. to FU(TURBO)-30, INSTALLATION, Camshaft Position Sensor.>
- 3) Install the timing belt assembly. <Ref. to ME(TURBO)-50, INSTALLATION, Timing Belt Assembly.>
- 4) Install the belt cover. <Ref. to ME(TURBO)-47, INSTALLATION, Belt Cover.>
- 5) Install the crankshaft pulley. <Ref. to ME(TURBO)-46, INSTALLATION, Crankshaft Pulley.>
- 6) Install the V-belt. <Ref. to ME(TURBO)-44, INSTALLATION, V-belt.>

C: INSPECTION

- 1) Check the sprocket teeth for abnormal wear and scratches.
- 2) Make sure there is no free play between sprocket and key.
- 3) Check the crankshaft sprocket notch used for sensor for damage and contamination of foreign matter.