

AUTOMATIC TRANSMISSION

AT

	Page
1. General Description	2
2. Automatic Transmission Fluid	29
3. Differential Gear Oil.....	30
4. Road Test.....	31
5. Stall Test	32
6. Time Lag Test	34
7. Line Pressure Test	35
8. Transfer Clutch Pressure Test	37
9. Automatic Transmission Assembly	38
10. Transmission Mounting System	44
11. Extension Case Oil Seal	46
12. Differential Side Retainer Oil Seal.....	47
13. Inhibitor Switch.....	48
14. Front Vehicle Speed Sensor	52
15. Rear Vehicle Speed Sensor.....	56
16. Torque Converter Turbine Speed Sensor	57
17. Control Valve Body	58
18. Shift Solenoids, Duty Solenoids and ATF Temperature Sensor	64
19. Transfer Duty Solenoid and Valve Body	66
20. ATF Filter	69
21. Transmission Control Module (TCM)	70
22. ATF Cooler Pipe and Hose	71
23. Air Breather Hose.....	74
24. Oil Charger Pipe.....	75
25. Torque Converter Clutch Assembly	76
26. Extension Case	77
27. Transfer Clutch.....	79
28. Reduction Driven Gear.....	84
29. Reduction Drive Gear.....	86
30. Parking Pawl	88
31. Torque Converter Clutch Case	89
32. Oil Pump	92
33. Drive Pinion Shaft	98
34. Front Differential.....	103
35. High Clutch and Reverse Clutch	109
36. Planetary Gear and Low Clutch	114
37. 2-4 Brake.....	122
38. One-way Clutch.....	126
39. Low and Reverse Brake.....	130
40. Transmission Control Device	133

GENERAL DESCRIPTION

AUTOMATIC TRANSMISSION

1. General Description

A: SPECIFICATIONS

1. TORQUE CONVERTER CLUTCH

Model	2.0 L Non-turbo	2.5 L	2.0 L Turbo
Type	Symmetric, 3 element, single stage, 2 phase torque converter		
Stall torque ratio	2.0 — 2.2	1.9 — 2.1	1.85 — 2.15
Nominal diameter	246 mm (9.69 in)		
Stall speed (at sea level)	2,000 — 2,500 rpm	2,100 — 2,600 rpm	2,600 — 3,300 rpm
One-way clutch	Sprague type one-way clutch		

2. OIL PUMP

Type	Pracoid constant-displacement pump		
Driving method	Driven by engine		
Number of teeth	Inner rotor	9	
	Outer rotor	10	

3. TRANSMISSION CONTROL ELEMENT

Type	4-forward, 1-reverse, double-row planetary gears
Multi-plate clutch	3 sets
Multi-plate brake	2 sets
One-way clutch (sprague type)	1 sets

4. TRANSMISSION GEAR RATIO

	Gear ratio
1st	2.785
2nd	1.545
3rd	1.000
4th	0.694
Rev	2.272

5. PLANETARY GEAR AND PLATE

Model	2.0 L Non-turbo	2.5 L	2.0 L Turbo
Tooth number of front sun gear	33		
Tooth number of front pinion	21		
Tooth number of front internal gear	75		
Tooth number of rear sun gear	42		
Tooth number of rear pinion	17		
Tooth number of rear internal gear	75		
Drive & driven plate number of high clutch	4		5
Drive & driven plate number of low clutch	4	6	7
Drive & driven plate number of reverse clutch	2		
Drive & driven plate number of 2-4 brake	3		4
Drive & driven plate number of low & reverse brake	4	6	7

GENERAL DESCRIPTION

AUTOMATIC TRANSMISSION

6. SELECTOR POSITION

P (Park)	Transmission in neutral, output member immovable, and engine start possible
R (Reverse)	Transmission in reverse for backing
N (Neutral)	Transmission in neutral and engine start possible
D (Drive)	Automatic gear change 1st ← → 2nd ← → 3rd ← → 4th
3 (3rd)	Automatic gear change 1st ← → 2nd ← → 3rd ← 4th
2 (2nd)	Automatic gear change 1st ← → 2nd ← 3rd ← 4th
1 (1st)	1st gear locked (Deceleration possible 1st ← 2nd ← 3rd ← 4th)
Control method	Hydraulic remote control

9. TRANSFER

Model	2.0 L Non-turbo	2.5 L	2.0 L Turbo
Transfer type	Multi-plate transfer (MPT)		
Drive & driven plate number of transfer clutch	4	5	6
Control method	Electronic, hydraulic type		
Lubricant	The same Automatic transmission fluid used in automatic transmission		
1st reduction gear ratio	1.000 (53/53)		

7. HYDRAULIC CONTROL AND LUBRICATION

Type	Electronic/hydraulic control [Four forward speed changes by electrical signals of vehicle speed and accelerator (throttle) opening]	
Fluid	Dexron III type Automatic transmission fluid	
Fluid capacity	2.0 L Non-turbo model	8.4 — 8.7 ℓ (8.9 — 9.2 US qt, 7.4 — 7.7 Imp qt)
	2.5 L and 2.0 L Turbo model	9.3 — 9.6 ℓ (9.8 — 10.1 US qt, 8.2 — 8.4 Imp qt)
Lubrication system	Forced feed lubrication with oil pump	
Oil	Automatic transmission fluid (above mentioned)	

8. COOLING AND HARNESS

Cooling system	Liquid-cooled cooler incorporated in radiator
Inhibitor switch	12 poles
Transmission harness	20 poles

GENERAL DESCRIPTION

AUTOMATIC TRANSMISSION

10.FINAL REDUCTION

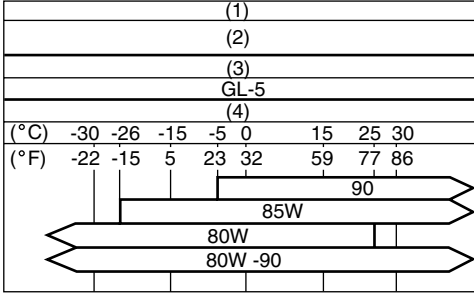
Model	Turbo	Non-turbo
Front final gear ratio	4.111 (37/9)	4.444 (40/9)
Lubrication oil		
Front differential oil capacity	1.1 — 1.3 ℓ (1.2 — 1.4 US qt, 1.0 — 1.1 Imp qt)	

AT-00001

- | | | |
|---------------------------------|------------------------|--|
| (1) ITEM | (3) API Classification | (4) SAE viscosity No. and applicable temperature |
| (2) Front differential gear oil | | |

B: COMPONENT

1. TORQUE CONVERTER CLUTCH AND CASE

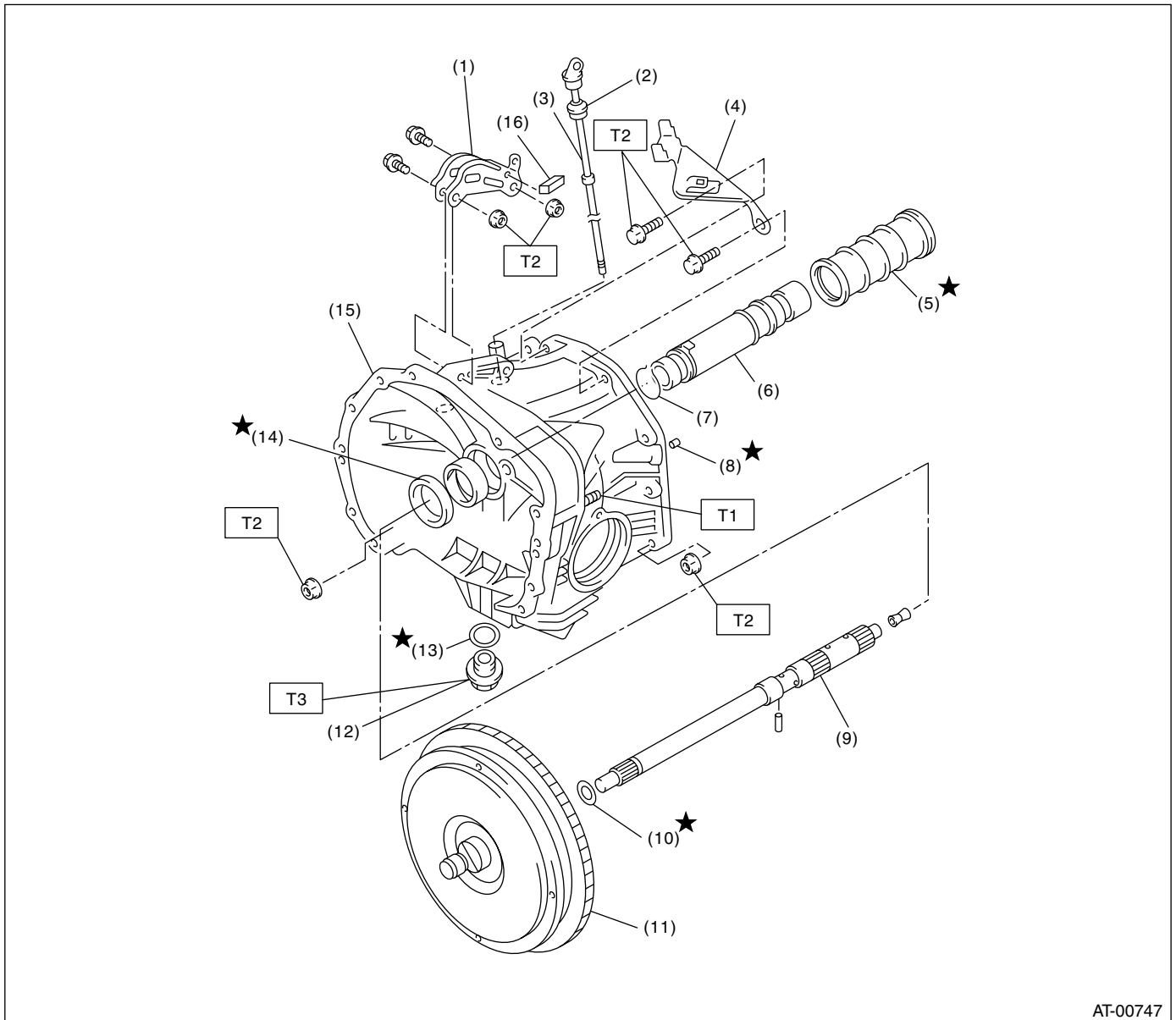

AT-00747

- | | |
|----------------------------------|-----------------------------------|
| (1) Pitching stopper bracket | (8) Oil drain pipe |
| (2) O-ring | (9) Input shaft |
| (3) Differential oil level gauge | (10) O-ring |
| (4) Stay | (11) Torque converter clutch ASSY |
| (5) Seal pipe | (12) Drain plug |
| (6) Oil pump shaft | (13) Gasket |
| (7) Clip | (14) Oil seal |

- | |
|-----------------------------------|
| (15) Torque converter clutch case |
| (16) Clip |

Tightening torque: N·m (kgf·m, ft·lb)

T1: 18 (1.8, 13.0)

T2: 41 (4.2, 30.4)

T3: 44 (4.5, 32.5)

GENERAL DESCRIPTION

AUTOMATIC TRANSMISSION

2. OIL PUMP

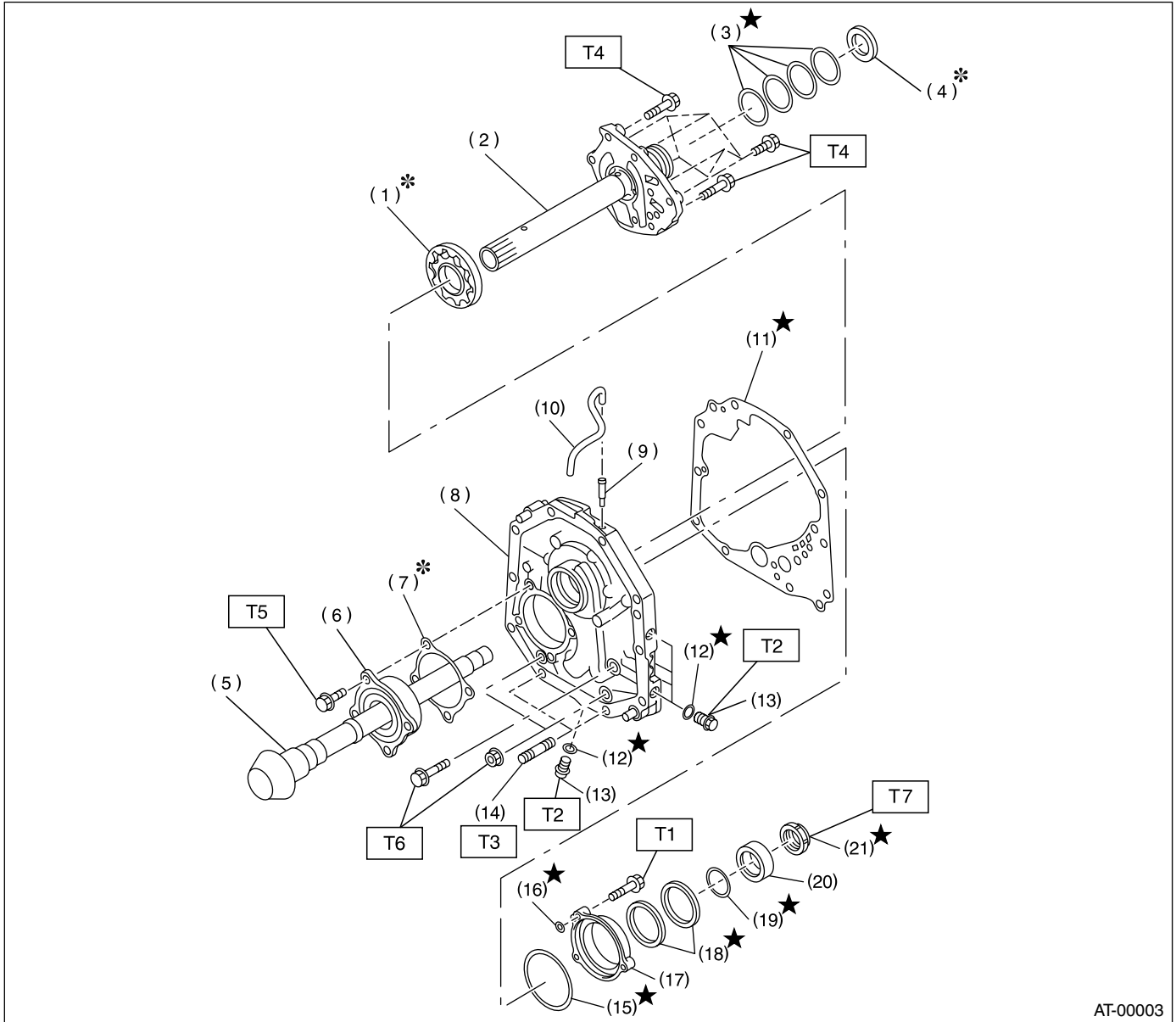

AT-00003

- | | |
|---------------------------|--------------------------|
| (1) Oil pump rotor | (12) O-ring |
| (2) Oil pump cover | (13) Test plug |
| (3) Seal ring | (14) Stud bolt |
| (4) Thrust needle bearing | (15) O-ring |
| (5) Drive pinion shaft | (16) O-ring |
| (6) Roller bearing | (17) Oil seal retainer |
| (7) Shim | (18) Oil seal |
| (8) Oil pump housing | (19) O-ring |
| (9) Nipple | (20) Drive pinion collar |
| (10) Air breather hose | (21) Lock nut |
| (11) Gasket | |

Tightening torque: N-m (kgf-m, ft-lb)

- | |
|---------------------------|
| T1: 7 (0.7, 5.1) |
| T2: 13 (1.3, 9.4) |
| T3: 18 (1.8, 13.0) |
| T4: 25 (2.5, 18.1) |
| T5: 40 (4.1, 30) |
| T6: 42 (4.3, 31) |
| T7: 116 (11.8, 85) |

3. TRANSMISSION CASE AND CONTROL DEVICE

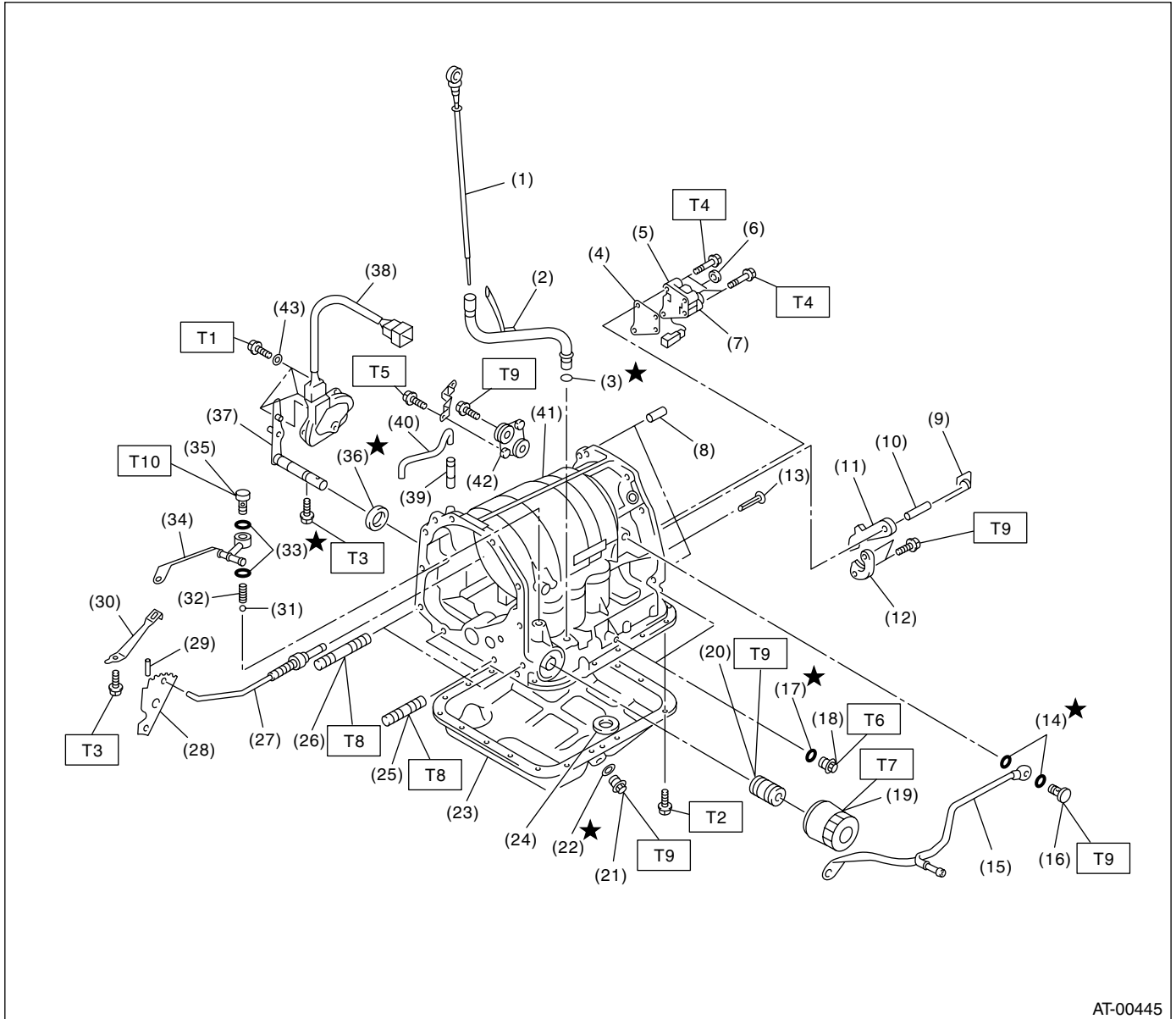

AT-00445

GENERAL DESCRIPTION

AUTOMATIC TRANSMISSION

(1) ATF level gauge	(20) Oil filter stud bolt	(38) Inhibitor switch ASSY
(2) ATF charger pipe	(21) Drain plug	(39) Nipple
(3) O-ring	(22) Gasket	(40) Air breather hose
(4) Transfer valve plate	(23) Oil pan	(41) Transmission case
(5) Transfer valve ASSY	(24) Magnet	(42) Plate ASSY
(6) Transfer clutch seal	(25) Stud bolt (Short)	(43) Washer
(7) Transfer duty solenoid	(26) Stud bolt (Long)	
(8) Straight pin	(27) Parking rod	
(9) Return spring	(28) Manual plate	<hr/> Tightening torque: N·m (kgf·m, ft·lb)
(10) Shaft	(29) Spring pin	T1: 3.4 (0.35, 2.5)
(11) Parking pawl	(30) Detention spring	T2: 5 (0.5, 3.6)
(12) Parking support	(31) Ball	T3: 6 (0.6, 4)
(13) Inlet filter	(32) Spring	T4: 8 (0.8, 6)
(14) Gasket	(33) Gasket	T5: 12 (1.2, 8.7)
(15) Inlet pipe	(34) Outlet pipe	T6: 13 (1.3, 10)
(16) Union screw	(35) Union screw	T7: 14 (1.4, 10)
(17) O-ring	(22) Gasket	T8: 18 (1.8, 13)
(18) Test plug	(36) Oil seal	T9: 25 (2.6, 18)
(19) Oil filter	(37) Select lever	T10: 44 (4.5, 32) <hr/>

4. CONTROL VALVE AND HARNESS ROUTING

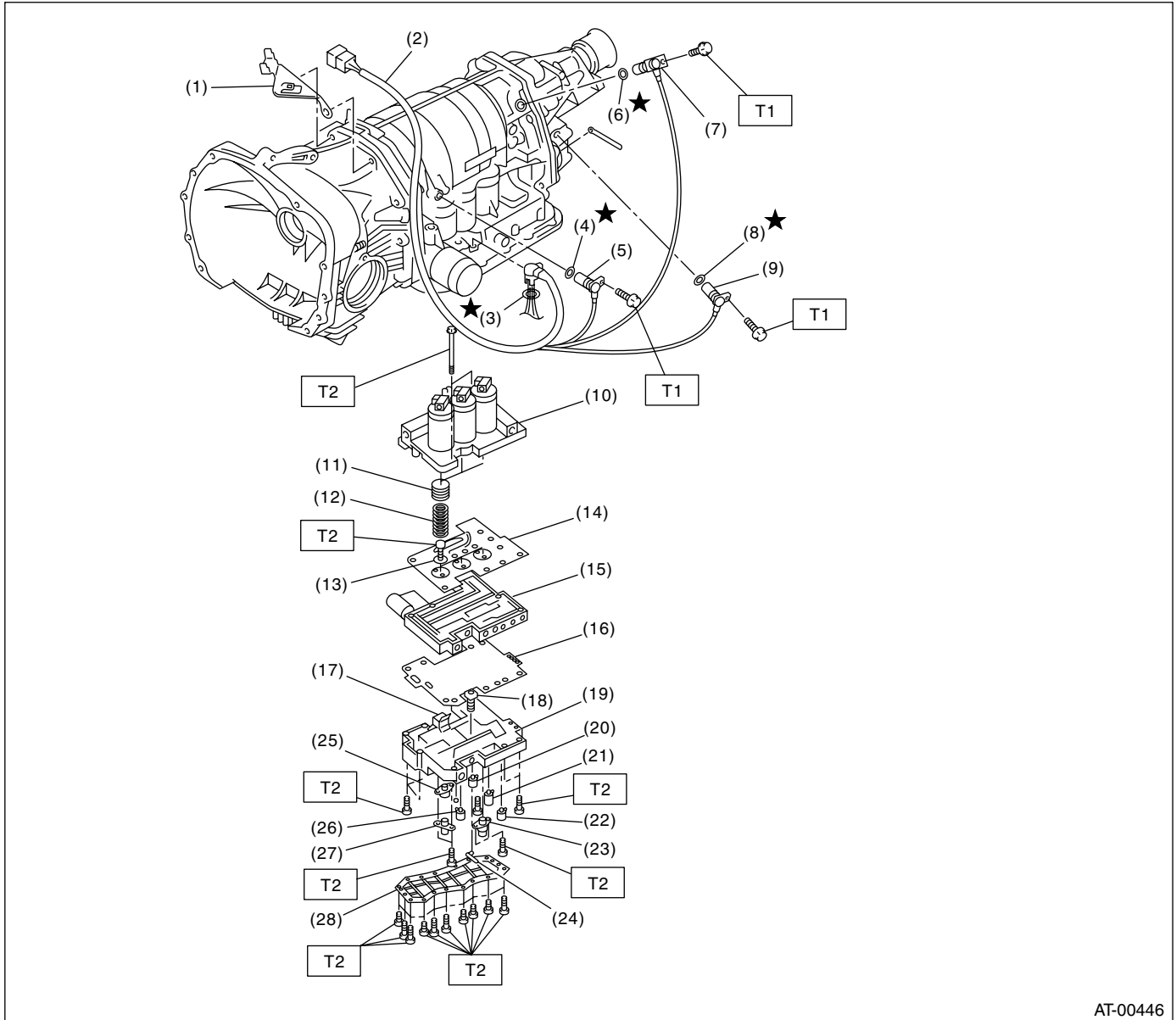

AT-00446

- | | | |
|---|-------------------------|----------------------------------|
| (1) Stay | (11) Accumulator piston | (22) 2-4 brake timing solenoid |
| (2) Transmission harness | (12) Accumulator spring | (23) 2-4 brake duty solenoid |
| (3) O-ring | (13) Side plate | (24) ATF temperature sensor |
| (4) O-ring | (14) Separate plate | (25) Line pressure duty solenoid |
| (5) Torque converter turbine speed sensor | (15) Middle valve body | (26) Low clutch timing solenoid |
| (6) O-ring | (16) Separate plate | (27) Lock-up duty solenoid |
| (7) Front vehicle speed sensor | (17) Fluid filter | (28) Oil strainer |
| (8) O-ring | (18) Fluid filter | |
| (9) Rear vehicle speed sensor | (19) Lower valve body | |
| (10) Upper valve body | (20) Shift solenoid 2 | |
| | (21) Shift solenoid 1 | |

Tightening torque: N·m (kgf·m, ft·lb)

T1: 7 (0.7, 5.1)

T2: 8 (0.8, 5.8)

GENERAL DESCRIPTION

AUTOMATIC TRANSMISSION

5. HIGH CLUTCH AND REVERSE CLUTCH

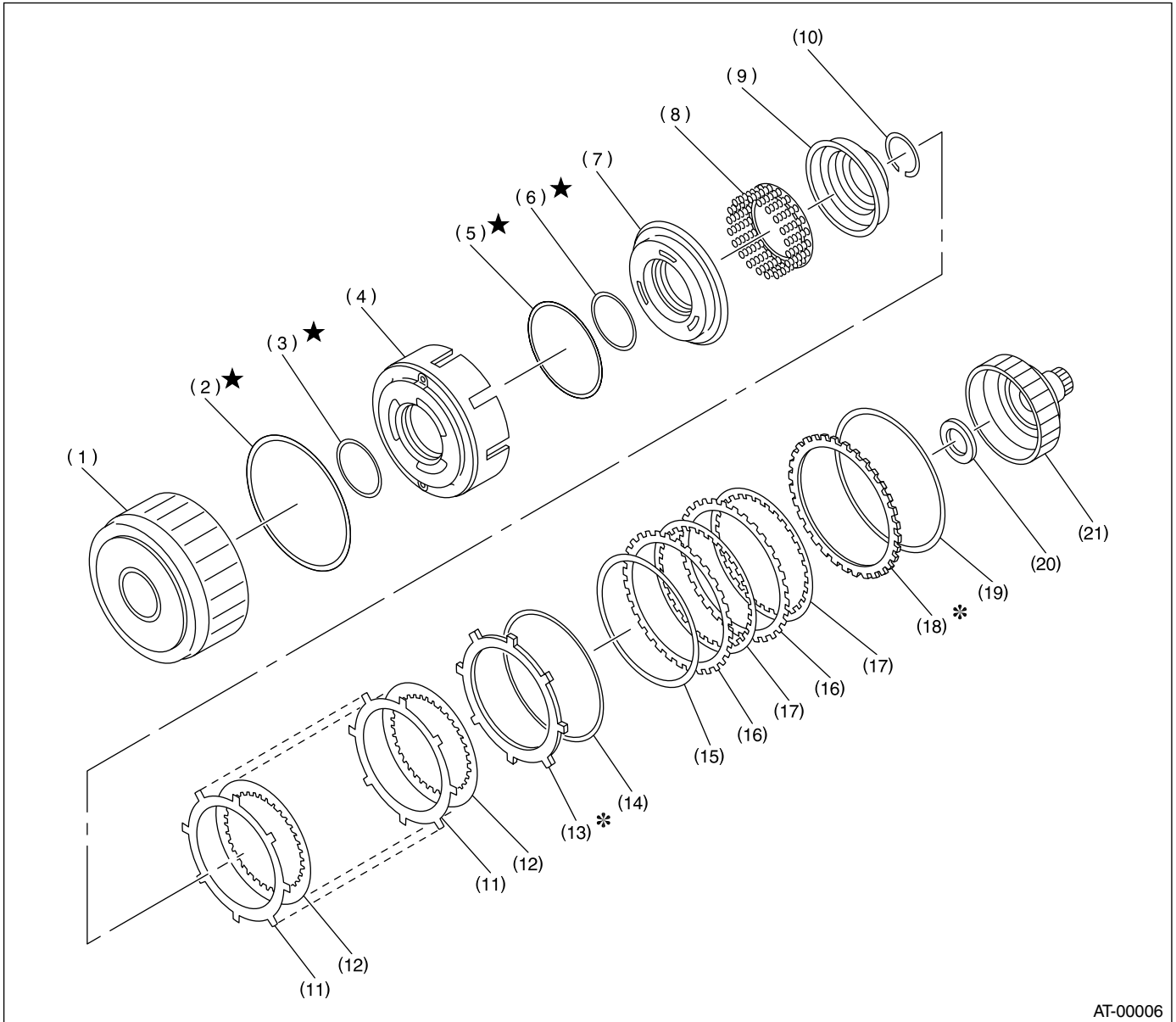

AT-00006

- | | | |
|---------------------------|----------------------|----------------------------|
| (1) High clutch drum | (8) Spring retainer | (15) Dish plate |
| (2) Lip seal | (9) Cover | (16) Driven plate |
| (3) Lathe cut seal ring | (10) Snap ring | (17) Drive plate |
| (4) Reverse clutch piston | (11) Driven plate | (18) Retaining plate |
| (5) Lathe cut seal ring | (12) Drive plate | (19) Snap ring |
| (6) Lathe cut seal ring | (13) Retaining plate | (20) Thrust needle bearing |
| (7) High clutch piston | (14) Snap ring | (21) High clutch hub |

6. PLANETARY GEAR AND 2-4 BRAKE

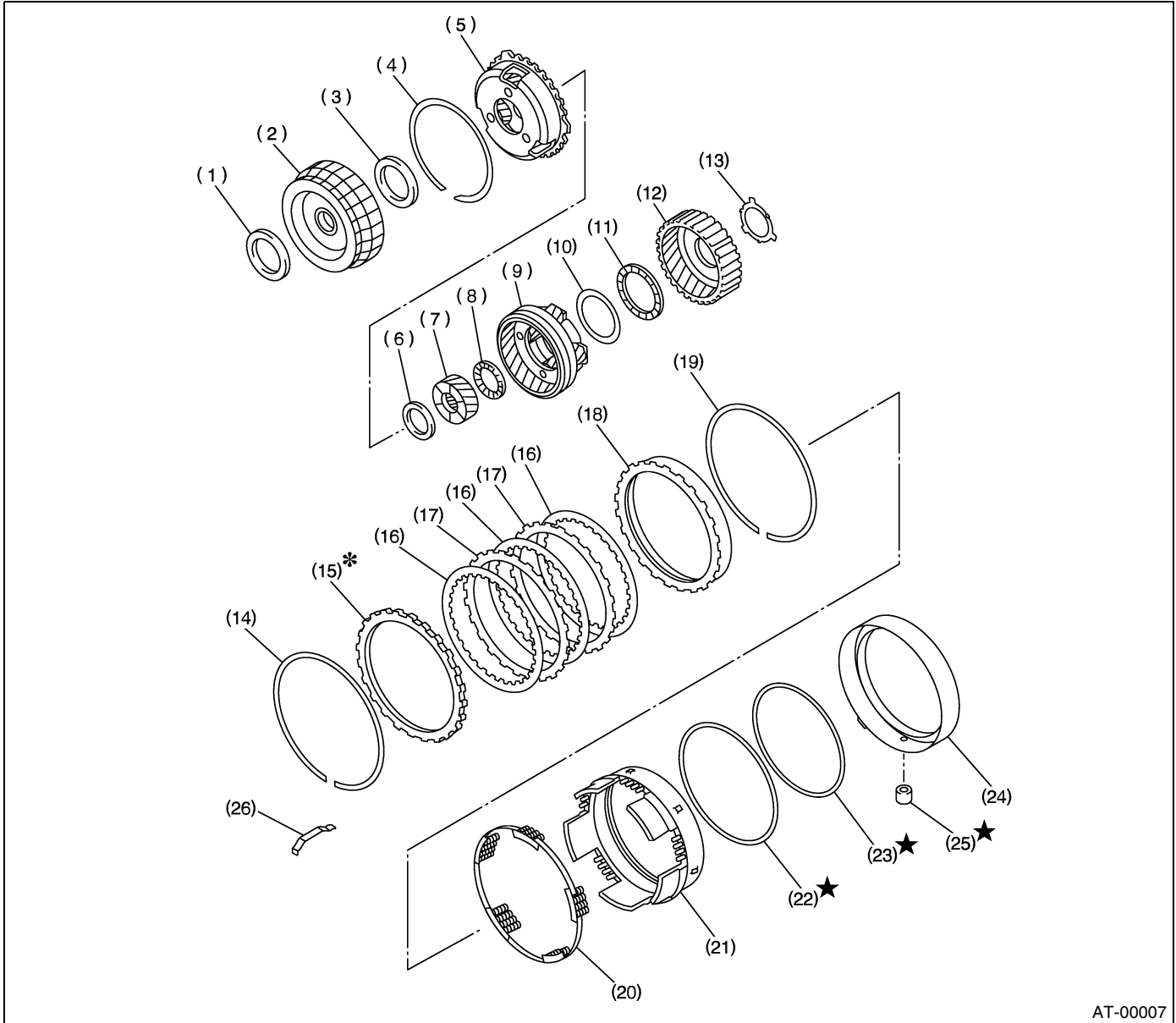

AT-00007

- | | | |
|-----------------------------|----------------------------|--------------------------------|
| (1) Thrust needle bearing | (10) Washer | (19) Snap ring |
| (2) Front sun gear | (11) Thrust needle bearing | (20) Spring retainer |
| (3) Thrust needle bearing | (12) Rear internal gear | (21) 2-4 brake piston |
| (4) Snap ring | (13) Washer | (22) Lathe cut seal ring |
| (5) Front planetary carrier | (14) Snap ring | (23) Lathe cut seal ring |
| (6) Thrust needle bearing | (15) Retaining plate | (24) 2-4 brake piston retainer |
| (7) Rear sun gear | (16) Drive plate | (25) 2-4 brake seal |
| (8) Thrust needle bearing | (17) Driven plate | (26) Leaf spring |
| (9) Rear planetary carrier | (18) Pressure rear plate | |

GENERAL DESCRIPTION

AUTOMATIC TRANSMISSION

7. LOW CLUTCH AND LOW & REVERSE BRAKE

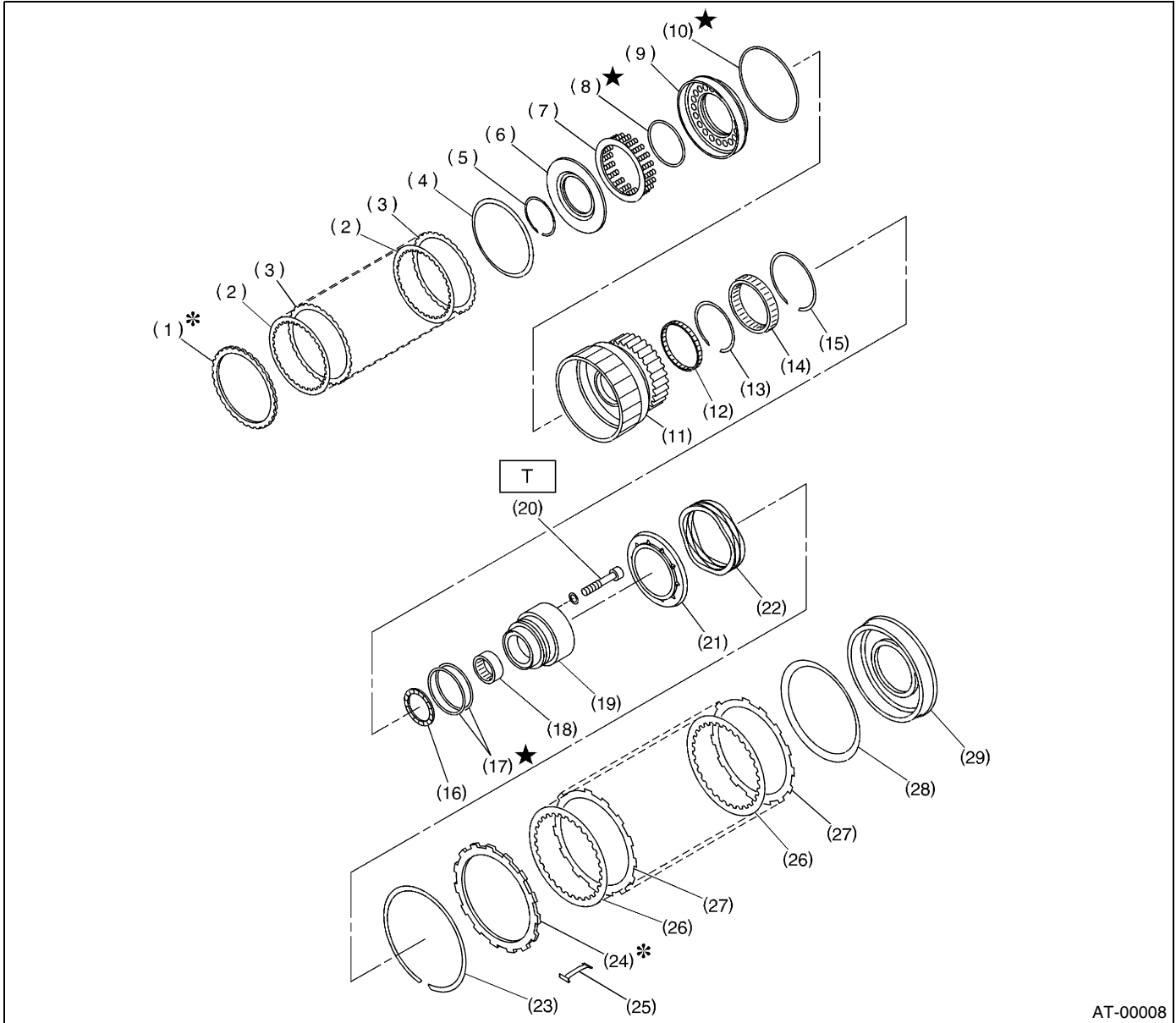

AT-00008

- | | | |
|--------------------------|--------------------------------|-----------------------------------|
| (1) Retaining plate | (12) Needle bearing | (23) Snap ring |
| (2) Drive plate | (13) Inner snap ring | (24) Retaining plate |
| (3) Driven plate | (14) One-way clutch | (25) Leaf spring |
| (4) Dish plate | (15) Outer snap ring | (26) Drive plate |
| (5) Snap ring | (16) Thrust needle bearing | (27) Driven plate |
| (6) Cover | (17) Seal ring | (28) Dish plate |
| (7) Spring retainer | (18) Needle bearing | (29) Low and reverse brake piston |
| (8) Lathe cut seal ring | (19) One-way clutch inner race | |
| (9) Low clutch piston | (20) Socket bolt | |
| (10) Lathe cut seal ring | (21) Spring retainer | |
| (11) Low clutch drum | (22) Return spring | |

Tightening torque: N·m (kgf-m, ft-lb)

T: 25 (2.5, 18.1)

8. REDUCTION GEAR WITHOUT VTD

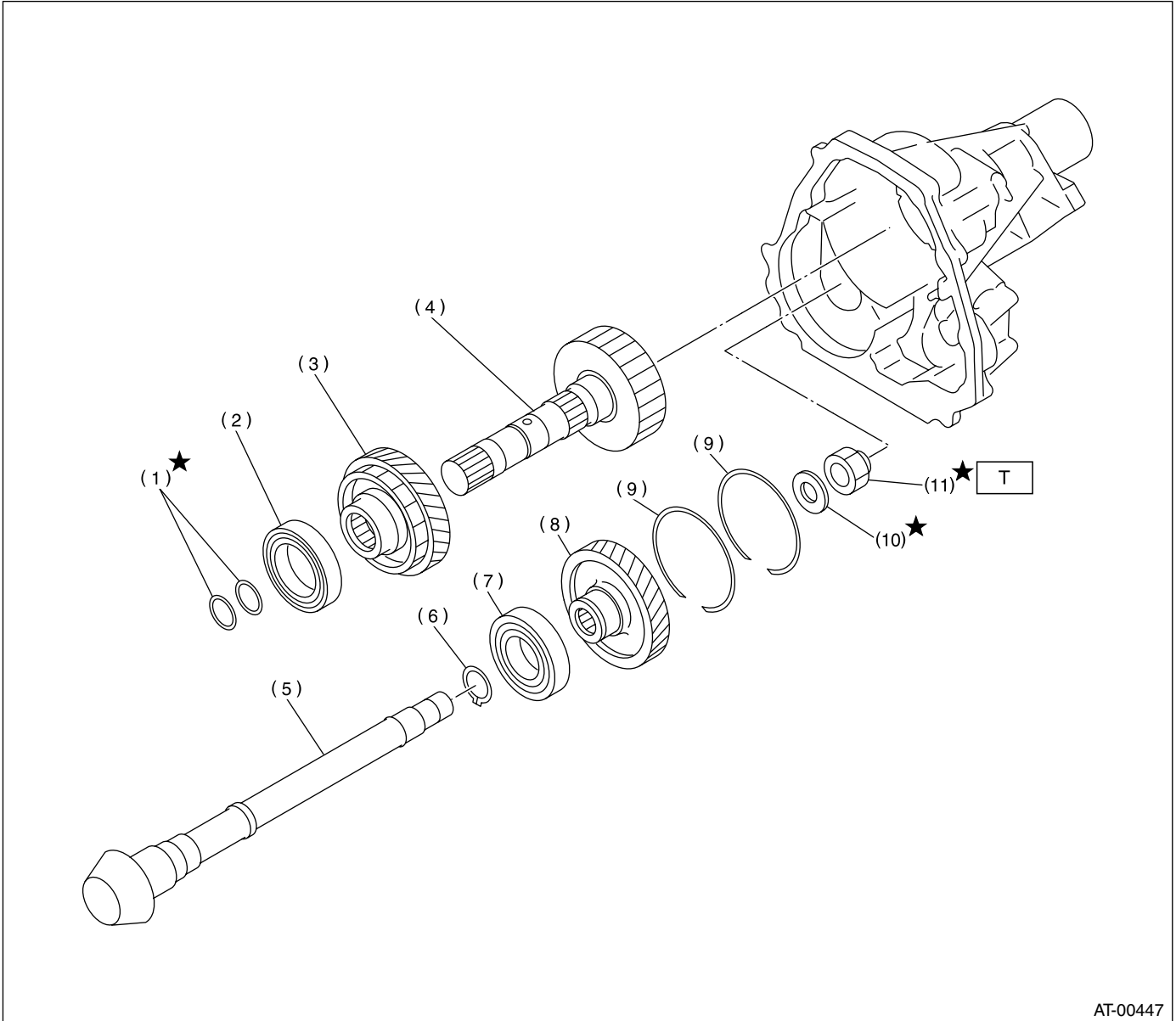

AT-00447

- (1) Seal ring
- (2) Ball bearing
- (3) Reduction drive gear
- (4) Reduction drive shaft
- (5) Drive pinion shaft

- (6) Snap ring
- (7) Ball bearing
- (8) Reduction driven gear
- (9) Snap ring
- (10) Washer

- (11) Lock nut

Tightening torque: N·m (kgf·m, ft·lb)
T: 100 (10.2, 73.8)

GENERAL DESCRIPTION

AUTOMATIC TRANSMISSION

9. DIFFERENTIAL GEAR

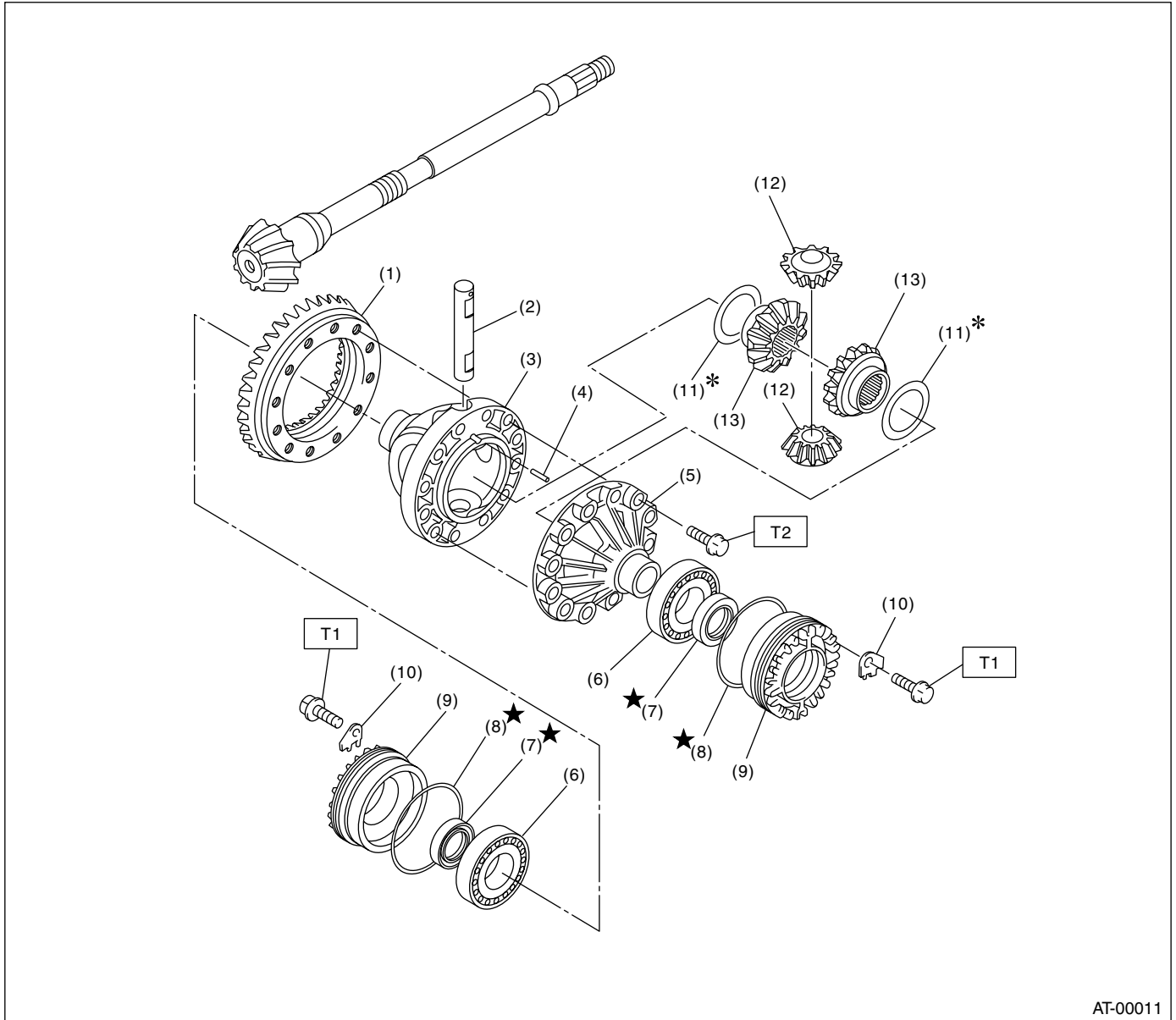

AT-00011

- | | | |
|----------------------------|--------------------------------|------------------------------|
| (1) Crown gear | (7) Oil seal | (13) Differential bevel gear |
| (2) Pinion shaft | (8) O-ring | |
| (3) Differential case (RH) | (9) Differential side retainer | |
| (4) Straight pin | (10) Lock plate | |
| (5) Differential case (LH) | (11) Washer | |
| (6) Taper roller bearing | (12) Differential bevel pinion | |

Tightening torque: N·m (kgf·m, ft·lb)

T1: 25 (2.5, 18.1)

T2: 62 (6.3, 45.6)

10. TRANSFER AND EXTENSION CASE

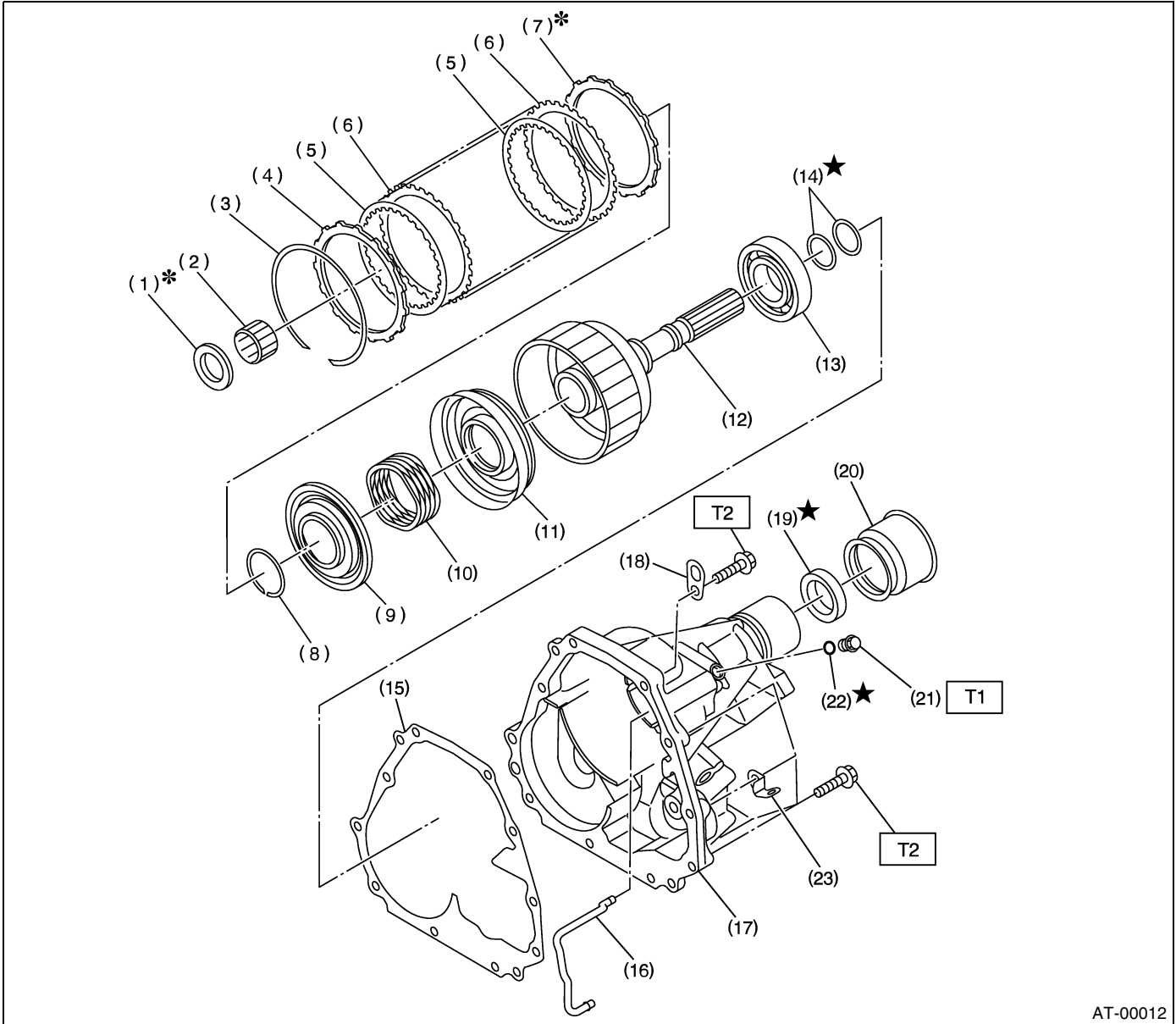

AT-00012

- (1) Thrust needle bearing
- (2) Needle bearing
- (3) Snap ring
- (4) Pressure plate
- (5) Drive plate
- (6) Driven plate
- (7) Pressure plate
- (8) Snap ring
- (9) Transfer piston seal

- (10) Return spring
- (11) Transfer clutch piston
- (12) Rear drive shaft
- (13) Ball bearing
- (14) Seal ring
- (15) Gasket
- (16) Transfer clutch pipe
- (17) Extension case
- (18) Transmission hanger

- (19) Oil seal
- (20) Dust cover
- (21) Test plug
- (22) O-ring
- (23) Clip

Tightening torque: N·m (kgf·m, ft·lb)

T1: 13 (1.3, 9.4)

T2: 25 (2.5, 18.1)

GENERAL DESCRIPTION

AUTOMATIC TRANSMISSION

11. TRANSMISSION MOUNTING

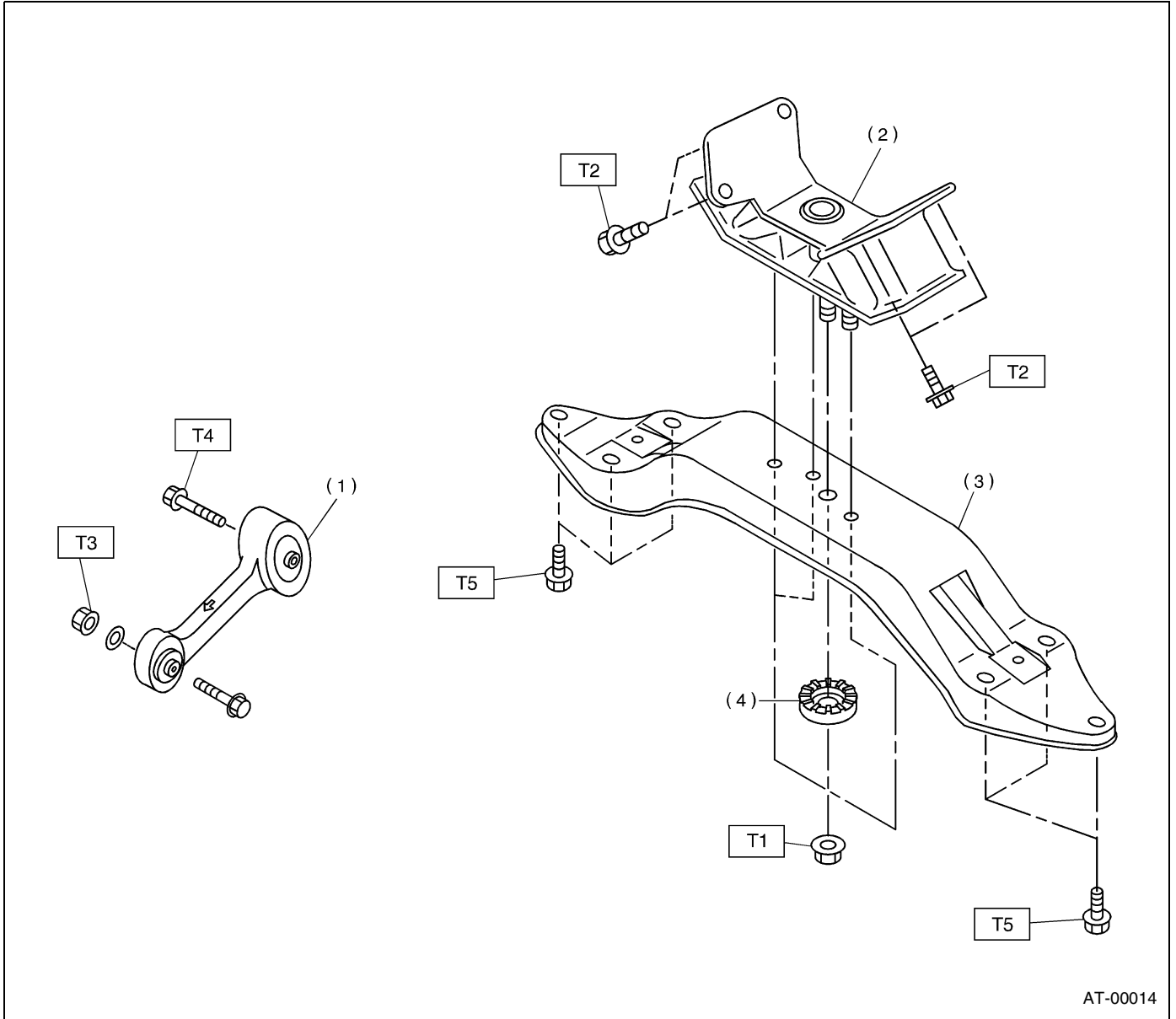

AT-00014

- (1) Pitching stopper
- (2) Rear cushion rubber
- (3) Transmission rear crossmember
- (4) Stopper

Tightening torque: N-m (kgf-m, ft-lb)

T1: 35 (3.6, 26)

T2: 39 (4.0, 29)

T3: 50 (5.1, 37)

T4: 58 (5.9, 43)

T5: 70 (7.1, 51)

GENERAL DESCRIPTION

AUTOMATIC TRANSMISSION

C: CAUTION

- Wear working clothing, including a cap, protective goggles, and protective shoes during operation.
- Remove contamination including dirt and corrosion before removal, installation, and disassembly.
- Keep the disassembled parts in order and protect them from dust or dirt.
- Until the oil pan is removed, do not place with the oil pan side facing up to prevent foreign matter from entering the valve body.
- Before removal, installation or disassembly, be sure to clarify the failure. Avoid unnecessary removal, installation, disassembly and replacement.
- When disassembling the case and other light alloy parts, use a plastic hammer to force it apart. Do not pry it apart with a screwdriver or other tool.
- Be careful not to burn your hands, because each part on the vehicle is hot after running.

- Use SUBARU genuine gear oil, grease etc. or the equivalent. Do not mix gear oil, grease etc. with that of another grade or from other manufacturers.
- Be sure to tighten fasteners including bolts and nuts to the specified torque.
- Place shop jacks or safety stands at the specified points.
- Apply gear oil onto sliding or revolution surfaces before installation.
- Replace deformed or otherwise damaged snap rings with new ones.
- Before installing O-rings or oil seals, apply sufficient amount of ATF fluid to avoid damage and deformation.
- Be careful not to incorrectly install or fail to install O-rings, snap rings and other such parts.
- Before securing a part on a vise, place cushioning material such as wood blocks, aluminum plate, or shop cloth between the part and the vise.
- Avoid damaging the mating surface of the case.
- Before applying sealant, completely remove the old seal.

D: PREPARATION TOOL

1. SPECIAL TOOLS

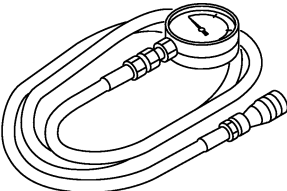
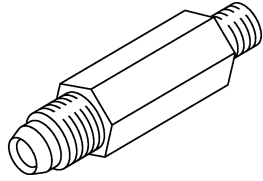
ILLUSTRATION	TOOL NUMBER	DESCRIPTION	REMARKS
 <p>ST-498575400</p>	498575400	OIL PRESSURE GAUGE ASSY	Used for measuring oil pressure.
 <p>ST-498897200</p>	498897200	ADAPTER	Used oil pump housing when measuring reverse clutch pressure and line pressure.

GENERAL DESCRIPTION

AUTOMATIC TRANSMISSION

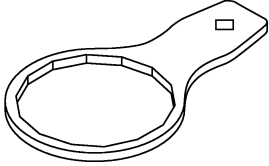
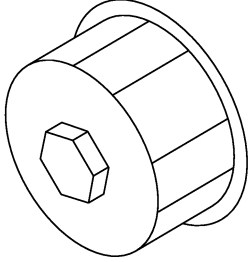
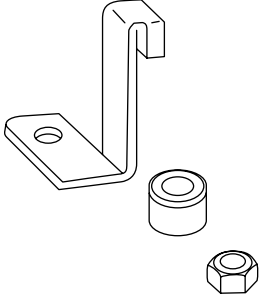
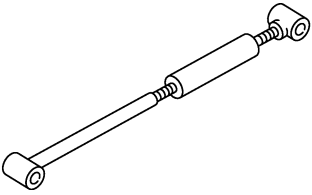
ILLUSTRATION	TOOL NUMBER	DESCRIPTION	REMARKS
 <p style="text-align: center;">ST-498545400</p>	<p style="text-align: center;">498545400</p>	<p style="text-align: center;">FILTER WRENCH</p>	<p>Used for removing and installing ATF filter.</p>
 <p style="text-align: center;">ST18332AA000</p>	<p style="text-align: center;">18332AA000 <Newly adopted tool></p>	<p style="text-align: center;">OIL FILTER WRENCH</p>	<ul style="list-style-type: none"> • Used for removing and installing ATF filter. • Used as oil filter wrench for Turbo model.
 <p style="text-align: center;">ST-498277200</p>	<p style="text-align: center;">498277200</p>	<p style="text-align: center;">STOPPER SET</p>	<p>Used for removing and installing automatic transmission assembly to engine.</p>
 <p style="text-align: center;">ST41099AA020</p>	<p style="text-align: center;">41099AA020</p>	<p style="text-align: center;">ENGINE SUPPORT</p>	<p>Used for supporting engine.</p>

GENERAL DESCRIPTION

AUTOMATIC TRANSMISSION

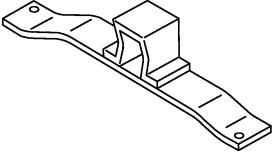
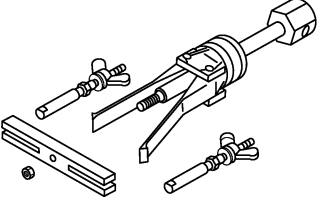
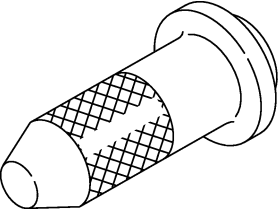
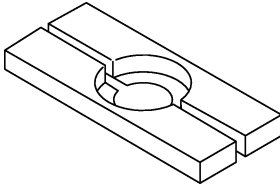
ILLUSTRATION	TOOL NUMBER	DESCRIPTION	REMARKS
 <p data-bbox="342 579 472 604">ST4199AA010</p>	41099AA010	ENGINE SUPPORT BRACKET	Used for supporting engine.
 <p data-bbox="342 999 472 1024">ST-398527700</p>	398527700	PULLER ASSY	<ul style="list-style-type: none"> • Used for removing extension case roller bearing. • Used for removing extension oil seal. • Used for removing front differential side retainer bearing outer race. • Used for removing front differential side retainer bearing outer ball race.
 <p data-bbox="342 1419 472 1444">ST-498057300</p>	498057300	INSTALLER	Used for installing extension oil seal.
 <p data-bbox="342 1839 472 1864">ST-498077000</p>	498077000	REMOVER	Used for removing differential taper roller bearing.

GENERAL DESCRIPTION

AUTOMATIC TRANSMISSION

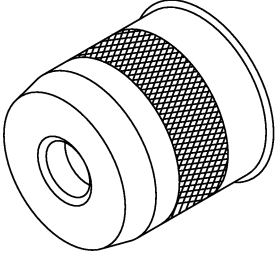
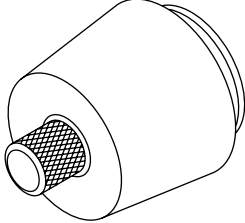
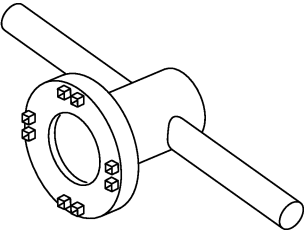
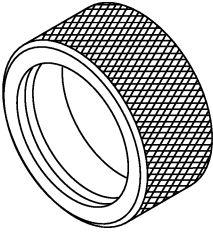
ILLUSTRATION	TOOL NUMBER	DESCRIPTION	REMARKS
 <p style="text-align: center;">ST-499247400</p>	499247400	INSTALLER	<ul style="list-style-type: none"> • Used for installing transfer outer snap ring. • Used with GUIDE (499257300).
 <p style="text-align: center;">ST-499257300</p>	499257300	SNAP RING OUTER GUIDE	<ul style="list-style-type: none"> • Used for installing transfer outer snap ring. • Used with INSTALLER (499247400).
 <p style="text-align: center;">ST-499787000</p>	499787000	WRENCH ASSY	Used for removing and installing differential side retainer.
 <p style="text-align: center;">ST-398437700</p>	398437700	DRIFT	Used for installing converter case oil seal.

GENERAL DESCRIPTION

AUTOMATIC TRANSMISSION

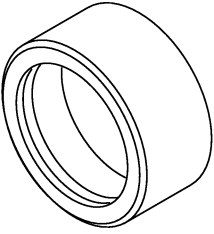
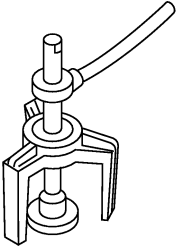
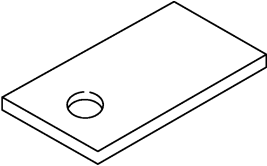
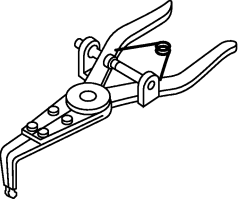
ILLUSTRATION	TOOL NUMBER	DESCRIPTION	REMARKS
 <p data-bbox="342 579 472 604">ST-398487700</p>	398487700	INSTALLER	Used for installing taper roller bearing of front differential.
 <p data-bbox="342 999 472 1024">ST-398673600</p>	398673600	COMPRESSOR	Used for removing and installing clutch spring.
 <p data-bbox="342 1419 472 1444">ST-498255400</p>	498255400	PLATE	Used for measuring backlash of hypoid gear.
 <p data-bbox="342 1839 472 1864">ST-399893600</p>	399893600	PLIERS	Used for removing and installing clutch spring.

GENERAL DESCRIPTION

AUTOMATIC TRANSMISSION

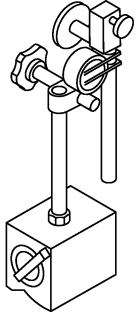
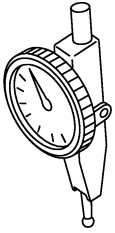
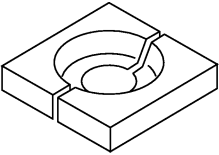
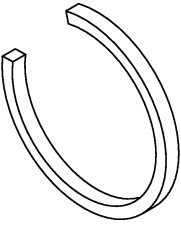
ILLUSTRATION	TOOL NUMBER	DESCRIPTION	REMARKS
 <p style="text-align: center;">ST-498247001</p>	498247001	MAGNET BASE	<ul style="list-style-type: none"> • Used for measuring gear backlash. • Used with DIAL GAUGE (498247100).
 <p style="text-align: center;">ST-498247100</p>	498247100	DIAL GAUGE	<ul style="list-style-type: none"> • Used for measuring gear backlash. • Used with MAGNET BASE (498247001).
 <p style="text-align: center;">ST-498517000</p>	498517000	REPLACER	Used for removing front roller bearing.
 <p style="text-align: center;">ST-398623600</p>	398623600	SEAT	Used for removing spring of transfer clutch piston.

GENERAL DESCRIPTION

AUTOMATIC TRANSMISSION

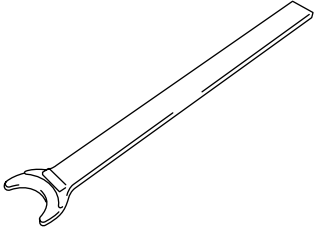
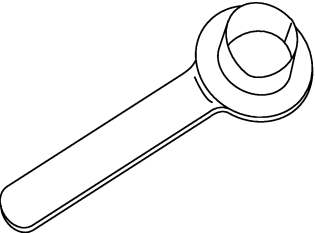
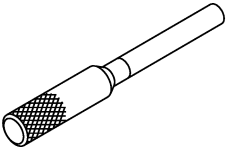
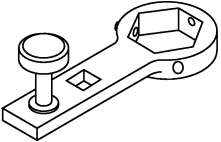
ILLUSTRATION	TOOL NUMBER	DESCRIPTION	REMARKS
 <p data-bbox="331 579 472 604">ST28399SA000</p>	<p data-bbox="516 197 691 279">28399SA000 <Newly adopted tool></p>	<p data-bbox="732 197 862 222">REMOVER</p>	<p data-bbox="974 197 1287 222">Used for removing axle shaft.</p>
 <p data-bbox="331 999 472 1024">ST28399SA010</p>	<p data-bbox="516 617 691 699">28399SA010 <Newly adopted tool></p>	<p data-bbox="732 617 886 642">PROTECTOR</p>	<p data-bbox="974 617 1287 642">Used for installing axle shaft.</p>
 <p data-bbox="339 1419 472 1444">ST-499267300</p>	<p data-bbox="540 1037 667 1062">499267300</p>	<p data-bbox="732 1037 894 1062">STOPPER PIN</p>	<p data-bbox="974 1037 1336 1062">Used for installing inhibitor switch.</p>
 <p data-bbox="339 1839 472 1864">ST-499787700</p>	<p data-bbox="540 1457 667 1482">499787700</p>	<p data-bbox="732 1457 846 1482">WRENCH</p>	<p data-bbox="974 1457 1487 1503">Used for removing and installing drive pinion lock nut.</p>

GENERAL DESCRIPTION

AUTOMATIC TRANSMISSION

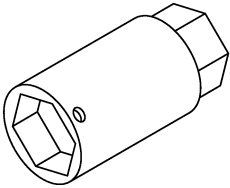
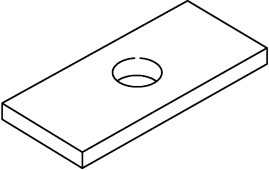
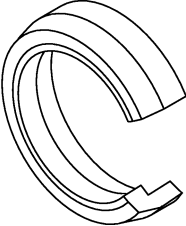
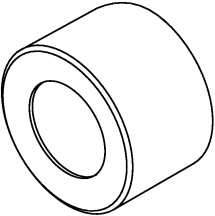
ILLUSTRATION	TOOL NUMBER	DESCRIPTION	REMARKS
 <p style="text-align: center;">ST-499787500</p>	<p style="text-align: center;">499787500</p>	<p style="text-align: center;">ADAPTER</p>	<p>Used for removing and installing drive pinion lock nut.</p>
 <p style="text-align: center;">ST-398643600</p>	<p style="text-align: center;">398643600</p>	<p style="text-align: center;">GAUGE</p>	<p>Used for measuring total end play, extension end play and drive pinion height.</p>
 <p style="text-align: center;">ST-498627100</p>	<p style="text-align: center;">498627100</p>	<p style="text-align: center;">SEAT</p>	<p>Used for holding low clutch piston retainer spring when installing snap ring.</p>
 <p style="text-align: center;">ST-499577000</p>	<p style="text-align: center;">499577000</p>	<p style="text-align: center;">GAUGE</p>	<ul style="list-style-type: none"> • Used for measuring the transmission case mating surface to the reduction gear end surface. • For without VTD.

GENERAL DESCRIPTION

AUTOMATIC TRANSMISSION

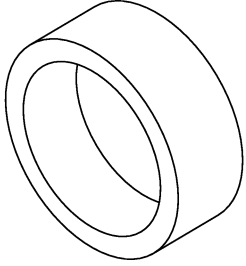
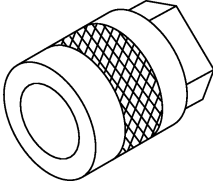
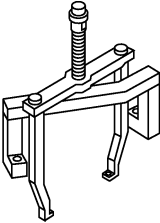
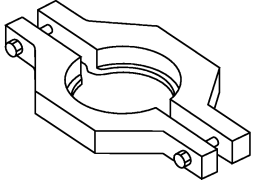
ILLUSTRATION	TOOL NUMBER	DESCRIPTION	REMARKS
 <p style="text-align: center;">ST-398744300</p>	<p style="text-align: center;">398744300</p>	<p style="text-align: center;">GAUGE</p>	<ul style="list-style-type: none"> • Used for measuring the transmission case mating surface to the multi-plate clutch end surface. • For with VTD.
 <p style="text-align: center;">ST-499737000</p>	<p style="text-align: center;">499737000</p>	<p style="text-align: center;">PULLER</p>	<p>Used for removing reduction driven gear assembly.</p>
 <p style="text-align: center;">ST-499737100</p>	<p style="text-align: center;">499737100</p>	<p style="text-align: center;">PULLER SET</p>	<p>Used for removing reduction drive gear assembly.</p>
 <p style="text-align: center;">ST-498077600</p>	<p style="text-align: center;">498077600</p>	<p style="text-align: center;">REMOVER</p>	<p>Used for removing ball bearing.</p>

GENERAL DESCRIPTION

AUTOMATIC TRANSMISSION

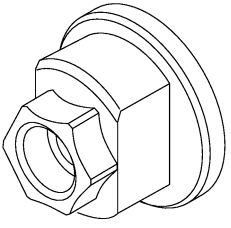
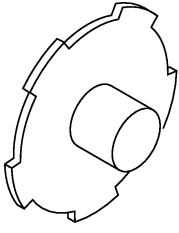
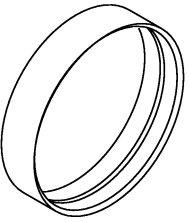
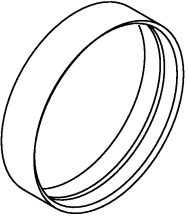
ILLUSTRATION	TOOL NUMBER	DESCRIPTION	REMARKS
 <p style="text-align: center;">ST-498937110</p>	<p style="text-align: center;">498937110</p>	<p>HOLDER</p>	<p>Used for removing and installing drive pinion lock nut.</p>
 <p style="text-align: center;">ST-498677100</p>	<p style="text-align: center;">498677100</p>	<p>COMPRESSOR</p>	<p>Used for installing 2-4 brake snap ring.</p>
 <p style="text-align: center;">ST-498437000</p>	<p style="text-align: center;">498437000</p>	<p>HIGH CLUTCH PISTON GUIDE</p>	<p>Used for installing high clutch piston.</p>
 <p style="text-align: center;">ST-498437100</p>	<p style="text-align: center;">498437100</p>	<p>LOW CLUTCH PISTON GUIDE</p>	<p>Used for installing low clutch piston.</p>

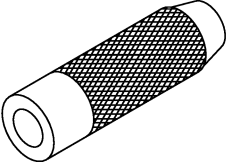
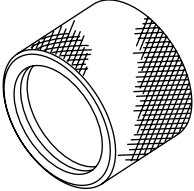
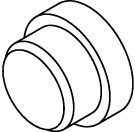
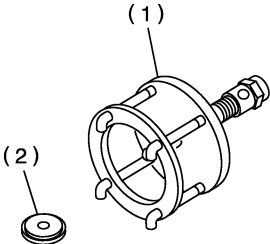

GENERAL DESCRIPTION

AUTOMATIC TRANSMISSION

ILLUSTRATION	TOOL NUMBER	DESCRIPTION	REMARKS
 <p style="text-align: center;">ST-899580100</p>	<p style="text-align: center;">899580100</p>	<p style="text-align: center;">INSTALLER</p>	<p>Used for press-fitting the ball bearing for transfer clutch.</p>
 <p style="text-align: center;">ST-18675AA000</p>	<p style="text-align: center;">18675AA000 <Newly adopted tool></p>	<p style="text-align: center;">DIFERENTIAL OIL SEAL INSTALLER</p>	<p>Used for installing differential side retainer oil seal.</p>
 <p style="text-align: center;">ST-398497701</p>	<p style="text-align: center;">398497701</p>	<p style="text-align: center;">ADAPTER</p>	<p>Used for installing needle bearing.</p>
 <p style="text-align: center;">ST-899524100</p>	<p style="text-align: center;">899524100</p>	<p style="text-align: center;">PULLER SET</p>	<ul style="list-style-type: none"> • Using the bolt only. (1) Bolt • Used with PULLER SET (499737100). • Used with PULLER (499737000). (1) Puller (2) Cap

GENERAL DESCRIPTION

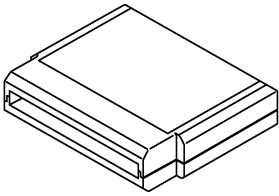
AUTOMATIC TRANSMISSION

ILLUSTRATION	TOOL NUMBER	DESCRIPTION	REMARKS
 ST24082AA210	24082AA210 <Newly adopted tool>	CARTRIDGE	Troubleshooting for electrical systems.
 ST22771AA010	22771AA010	SUBARU SELECT MONITOR KIT	Troubleshooting for electrical systems.

2. GENERAL PURPOSE TOOLS

TOOL NAME	REMARKS
Depth gauge	Used for measuring transmission end play.
Thickness gauge	Used for measuring clearances of clutch, brake and oil pump.
Micro meter	Used for measuring thickness of drive pinion.
Spring balance	Used for measuring starting torque of drive pinion.
Circuit tester	Used for measuring resistance and voltage.

2. Automatic Transmission Fluid

A: INSPECTION

CAUTION:

The level of ATF varies with fluid temperature. Pay attention to the fluid temperature when checking ATF level.

- 1) Raise the ATF temperature by driving a distance of 5 to 10 km (3 to 6 miles). Otherwise, idle the engine to raise ATF temperature to 60 — 80 °C (140 — 176 °F) on Subaru Select Monitor. <Ref. to AT-18, READ CURRENT DATA, OPERATION, Subaru Select Monitor.>
- 2) Make sure the vehicle is level.
- 3) After selecting all positions (P, R, N, D, 3, 2, 1), set the select lever in “P” range. Measure the ATF level with the engine idling for one or two minutes.

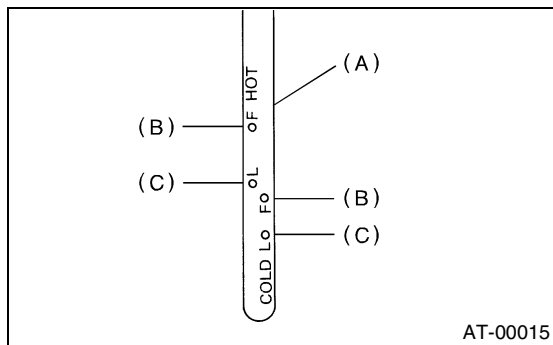

- (A) ATF level gauge
- (B) Upper level
- (C) Lower level

- 4) Make sure that ATF level is above the center of upper and lower marks.

NOTE:

When the transmission is hot, the level should be above the center of upper and lower marks, and when it is cold, the level should be found below the center of these two marks.

- 5) If the ATF level is below the center between upper and lower marks, add the recommended ATF until the ATF level is found above the center between upper and lower marks.

CAUTION:

- Use care not to exceed the upper limit level.
- Remember that the addition of ATF to the upper limit mark when the transmission is cold will result in overfilling of ATF, causing a transmission failure.

- 6) Check ATF level after raising ATF temperature to 60 — 80 °C (140 — 176 °F) by running the vehicle or by idling the engine again.
- 7) Check the ATF for leaks.

Check for leaks in the transmission. If there are leaks, it is necessary to repair or replace gasket, oil seals, plugs or other parts.

B: REPLACEMENT

- 1) Lift-up the vehicle.
- 2) Drain the ATF completely.

CAUTION:

Directly after the engine has been running, the ATF is hot. Be careful not to burn yourself.

- 3) Replace with a new gasket, and then tighten the ATF drain plug.

Tightening torque:

25 N·m (2.5 kgf-m, 18.1 ft-lb)

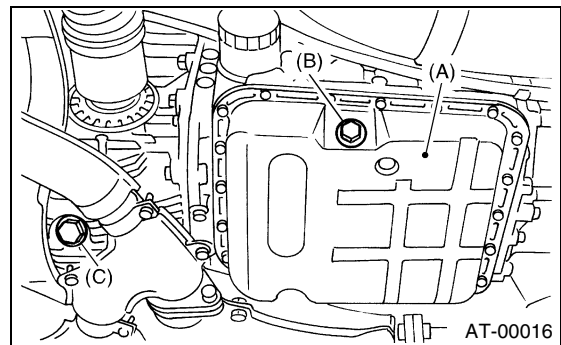

- (A) Oil pan
- (B) Drain plug (ATF)
- (C) Differential oil drain plug

- 4) Lower the vehicle.
- 5) Pour ATF into the oil charge pipe.

Recommended fluid:

Dexron III type automatic transmission fluid

Capacity:

Fill the same amount of fluid drained from drain plug hole.

Capacity when transmission is overhauled:

2.0 L Non-turbo model

8.4 — 8.7 ℓ (8.9 — 9.2 US qt, 7.4 — 7.7 Imp qt)

2.0 L Except Non-turbo model

9.3 — 9.6 ℓ (9.8 — 10.1 US qt, 8.2 — 8.4 Imp qt)

- 6) Check the level and leaks of ATF. <Ref. to AT-29, REPLACEMENT, Automatic Transmission Fluid.>

DIFFERENTIAL GEAR OIL

AUTOMATIC TRANSMISSION

3. Differential Gear Oil

A: INSPECTION

- 1) Park the vehicle on a level surface.
- 2) Remove the oil level gauge and wipe it clean.
- 3) Reinsert the level gauge all the way. Be sure that the level gauge is correctly inserted and in the proper orientation.
- 4) Remove it again and note the reading. If the differential gear oil level is below the "L" line, add oil to bring the level up to the "F" line.
- 5) To prevent overfilling the differential gear oil, do not add oil above the "F" line.

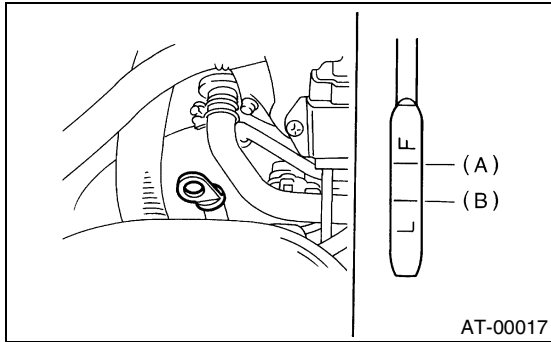

- (A) Upper level
(B) Lower level

B: REPLACEMENT

- 1) Lift-up the vehicle.
- 2) Drain the differential gear oil completely.

CAUTION:

- Directly after the engine has been running, the differential gear oil is hot. Be careful not to burn yourself.
 - Be careful not to spill the differential gear oil on exhaust pipe to prevent it from emitting smoke or fire. When the differential gear oil is spilled on exhaust pipe, wipe it away completely.
- 3) Replace the gasket with a new one, and then tighten the differential gear oil drain plug.

Tightening torque:

44 N·m (4.5 kgf·m, 32.5 ft·lb)

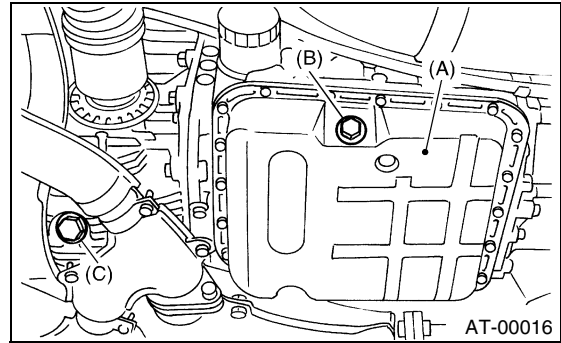

- (A) Oil pan
(B) Drain plug
(C) Differential oil drain plug

- 4) Lower the vehicle.
- 5) Pour gear oil into the gauge hole.

Recommended fluid:

Use GL-5 (SAE: 80W — 90) or equivalent.

Gear oil capacity:

1.1 — 1.3 ℓ (1.2 — 1.4 US qt, 1.0 — 1.1 Imp qt)

- 6) Check the level of differential gear oil.
<Ref. to AT-30, INSPECTION, Differential Gear Oil.>

4. Road Test**A: INSPECTION****1. GENERAL PRECAUTION**

Road tests should be conducted to properly diagnose the condition of the automatic transmission.

NOTE:

When performing the test, do not exceed posted speed limit.

2. D RANGE SHIFT FUNCTION

Check shifting between 1st ⇔ 2nd ⇔ 3rd ⇔ 4th while driving on normal city streets.

3. D RANGE SHIFT SHOCK

Check the shock level when shifting up during normal driving.

4. KICK-DOWN FUNCTION

Check the kick-down for each gear. Also check the kick-down shock level.

5. ENGINE BRAKE OPERATION

- Check the 3rd gear engine brake when shifting between D ⇔ 3rd range while driving in 4th gear of D range [50 to 60 km/h (31 to 37 MPH)].
- Check the 2nd gear engine brake when shifting between 3 ⇔ 2 range while driving in the 3 range 3rd gear [40 to 50 km/h (25 to 31 MPH)].
- Check the 1st gear engine brake when shifting between 2 ⇔ 1 range while driving in the 2 range 2nd gear [20 to 30 km/h (12 to 19 MPH)].

6. LOCK-UP FUNCTION

Check that rpm does not change sharply when the accelerator pedal is lightly depressed when driving on flat roads at normal speed in the lock-up range.

7. P RANGE OPERATION

Stop the vehicle on an uphill grade of 5% or more and shift to "P" range. Check that the vehicle does not move when the parking brake is released.

8. UNUSUAL SOUNDS AND VIBRATION

Check for unusual sounds and vibration while driving and during shifting.

9. CLIMBING CONTROL FUNCTION

- Check that the gear remains in 3rd when going up a grade.
- Check that the gear remains in 3rd when applying the brakes while going down a grade.

10. TRANSFER CLUTCH

Check if the tight corner braking occurs when the vehicle is started with steering wheel held at fully turned position.

11. OIL LEAKS

After the driving test, inspect for oil leaks.

5. Stall Test

A: INSPECTION

1. GENERAL INFORMATION

The stall test is of extreme importance in diagnosing the condition of the automatic transmission and the engine. It should be conducted to measure the engine stall speeds in "R" and "2" ranges.

Purposes of the stall test:

- 1) To check the operation of the automatic transmission clutch.
- 2) To check the operation of the torque converter clutch.
- 3) To check the engine performance.

2. TEST METHODS

- 1) Preparations before the test:
 - (1) Check that the throttle valve opens fully.
 - (2) Check that the engine oil level is correct.
 - (3) Check that the coolant level is correct.
 - (4) Check that the ATF level is correct.
 - (5) Check that the differential gear oil level is correct.
 - (6) Increase ATF temperature to 50 to 80°C (122 to 176°F) by idling the engine for approx. 30 minutes (with select lever set to "N" or "P").
- 2) Place the wheel chocks at the front and rear of all wheels and engage the parking brake.
- 3) Move the manual linkage to ensure it operates properly, and shift the select lever to the "2" range. And turn the hold switch on.
- 4) While forcibly depressing the foot brake pedal, gradually depress the accelerator pedal until the engine operates at full throttle.

may occur. To identify it, conduct the same test as above in "R" range.

- 8) Perform the stall tests with the select lever in "D" range.

NOTE:

- Do not continue the stall test for MORE THAN 5 SECONDS at a time (from closed throttle, fully open throttle to stall speed reading). Failure to follow this instruction causes the engine oil and ATF to deteriorate and the clutch and brake to be adversely affected.

Be sure to cool down the engine for at least 1 minute after each stall test with the select lever set in the "P" or "N" range and with the idle speed lower than 1,200 rpm.

- If the stall speed is higher than the specified range, attempt to finish the stall test in as short a time as possible, in order to prevent the automatic transmission from sustaining damage.

Stall speed (at sea level):

2.0 L Non-turbo model

2,000 — 2,500 rpm

2.0 L Turbo model

2,600 — 3,300 rpm

2.5 L model

2,100 — 2,600 rpm

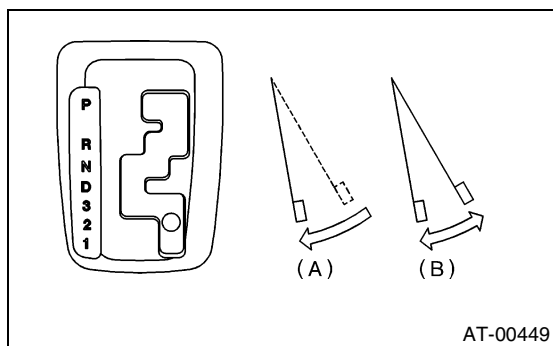

- (A) Brake pedal
- (B) Accelerator pedal

- 5) When the engine speed is stabilized, record that speed quickly and release the accelerator pedal.
- 6) Shift the select lever to "N" range, and cool down the engine by idling it for more than one minute.
- 7) If the stall speed in "2" range is higher than specifications, low clutch slipping and 2-4 brake slipping

STALL TEST

AUTOMATIC TRANSMISSION

3. EVALUATION

Stall speed (at sea level)	Position	Cause
Less than specifications	2 (Hold switch ON) R	<ul style="list-style-type: none">• Throttle valve not fully open• Erroneous engine operation• Torque converter clutch's one-way clutch slipping
	D	<ul style="list-style-type: none">• Line pressure too low• Low clutch slipping• One-way clutch malfunction
Greater than specifications	R	<ul style="list-style-type: none">• Line pressure too low• Reverse clutch slipping• Low & reverse brake slipping
	2 (Hold switch ON)	<ul style="list-style-type: none">• Line pressure too low• Low clutch slipping• 2-4 brake slipping• One-way clutch malfunction

6. Time Lag Test

A: INSPECTION

1. GENERAL INFORMATION

If the select lever is shifted while the engine is idling, there will be a certain time elapse or lag before the shock can be felt. This is used for checking the condition of the low clutch, reverse clutch, low & reverse brake and one-way clutch.

NOTE:

- Perform the test at normal operating fluid temperature 60 to 80°C (140 to 176°F).
- Be sure to allow a 1 minute interval between tests.
- Make three measurements and take the average value.

2. TEST METHODS

1) Fully apply the parking brake.

2) Start the engine.

Check the idling speed (A/C OFF).

3) Shift the select lever from "N" to "D" range.

Using a stop watch, measure the time it takes from shifting the lever until the shock is felt.

Time lag: Less than 1.2 seconds

4) In the same manner, measure the time lag for "N" → "R".

Time lag: Less than 1.5 seconds

3. EVALUATION

1) If "N" → "D" time lag is longer than specified:

- Line pressure too low
- Low clutch worn
- One-way clutch not operating properly

2) If "N" → "R" time lag is longer than specified:

- Line pressure too low
- Reverse clutch worn
- Low & reverse brake worn

7. Line Pressure Test

A: MEASUREMENT

1. GENERAL INFORMATION

If the clutch or the brake shows a sign of slippage or shifting sensation is not correct, the line pressure should be checked.

- Excessive shocks during upshifting or shifting takes place at a higher point than under normal circumstances, may be due to the line pressure being too high.
- Slippage or inability to operate the vehicle may, in most cases, be due to loss of oil pressure for the operation of the clutch, brake or control valve.

1) Line pressure measurement (under no load)

NOTE:

- Before measuring the line pressure, jack-up all wheels.
- Maintain the temperature of ATF at approx. 50°C (122°F) during measurement. (ATF will reach the above temperature after idling the engine for approx. 30 minutes with select lever in "N" or "P".)

2) Line pressure measurement (under heavy load)

NOTE:

- Before measuring the line pressure, apply both foot and parking brakes with all wheels chocked (Same as for "stall" test conditions).
- Measure the line pressure when select lever is in "R", "2" with engine under stall conditions.
- Measure the line pressure within 5 seconds after shifting the select lever to each position. (If line pressure needs to be measured again, allow the engine to idle. Wait for at least 1 minute before measurement.)
- Maintain the temperature of ATF at approx. 50°C (122°F) during measurement (ATF will reach the above temperature after idling the engine for approx. 30 minutes with the select lever in "N" or "P".)

2. TEST METHODS

1) Temporarily attach the ST to a suitable place in the driver's compartment, remove the blind plug located in front of the toe board and pass the hose of the ST to engine compartment.

ST 498575400 OIL PRESSURE GAUGE ASSY

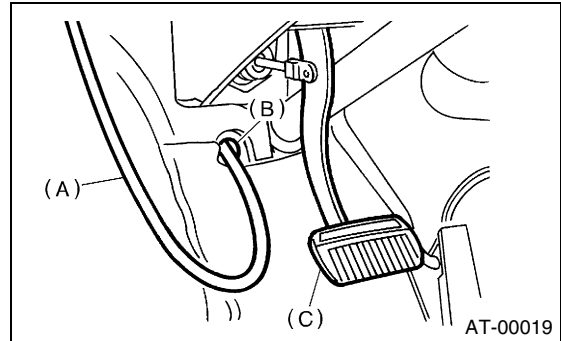

- (A) Pressure gauge hose
- (B) Hole in toe board (blank cap hole)
- (C) Brake pedal

2) Remove the test plug and install the ST instead.

ST 498897200 OIL PRESSURE GAUGE ADAPTER

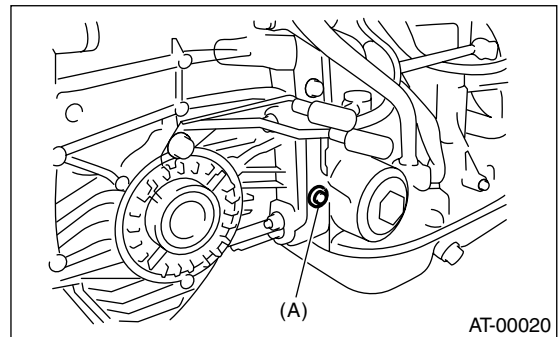

- (A) Test plug

3) Connect the ST1 with ST2.

ST1 498897200 OIL PRESSURE GAUGE ADAPTER

ST2 498575400 OIL PRESSURE GAUGE ASSY

LINE PRESSURE TEST

AUTOMATIC TRANSMISSION

4) Check for duty ratio changes by opening and closing the throttle valve using Subaru Select Monitor.

(1) Insert the cartridge to Subaru Select Monitor. <Ref. to AT-17, PREPARATION TOOL, General Description.>

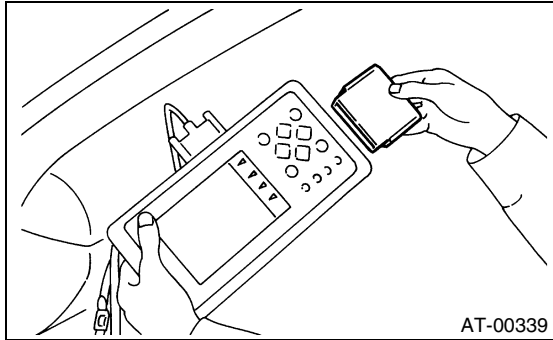

(2) Connect the Subaru Select Monitor to data link connector.

5) Check the line pressure in accordance with the following chart.

3. EVALUATION

Standard line pressure			
Range position	Line pressure duty ratio (%)	Throttle position	Line pressure kPa (kg/cm ² , psi)
2	5	Full open	1,128 — 1,304 (11.5 — 13.3, 164 — 189)
R	5	Full open	1,520 — 1,716 (15.5 — 17.5, 220 — 249)
D	95	Full closed	304 — 412 (3.1 — 4.2, 44 — 60)

8. Transfer Clutch Pressure Test

A: INSPECTION

1. TEST METHODS

Check the transfer clutch pressure in accordance with the following chart in the same manner as with line pressure. <Ref. to AT-35, Line Pressure Test.>

ST 498897700 OIL PRESSURE ADAPTER SET

ST 498575400 OIL PRESSURE GAUGE ASSY

AWD mode: "D" range

FWD mode: "P" range, engine speed 2,000 rpm

NOTE:

Before setting in FWD mode, install the spare fuse on FWD mode switch.

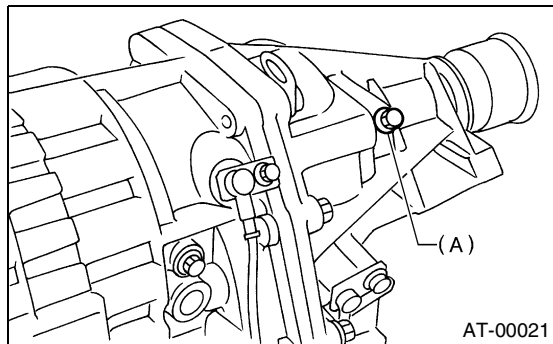

(A) Test plug

2. EVALUATION

NOTE:

If oil pressure is not produced or if it does not change in the AWD mode, the transfer duty solenoid or transfer valve assembly may be malfunctioning. If oil pressure is produced in the FWD mode, the problem is similar to that in the AWD mode.

Standard transfer clutch pressure kPa (kg/cm ² , psi)			
ON Duty ratio (%)	Throttle position	AWD mode	FWD mode
5	Full open	932 — 1,089 (9.5 — 11.1, 135 — 158)	—
60	2/3 throttle	216 — 294 (2.2 — 3.0, 31 — 43)	—
95	Full closed	—	0 (0, 0)

AUTOMATIC TRANSMISSION ASSEMBLY

AUTOMATIC TRANSMISSION

9. Automatic Transmission Assembly

A: REMOVAL

- 1) Set the vehicle on a lift.
- 2) Open the front hood fully, and support with stay.
- 3) Disconnect the ground cable from battery.
- 4) Remove the air intake duct. (Non-turbo model)
<Ref. to IN(SOHC)-7, REMOVAL, Air Intake Duct.>
- 5) Remove the air cleaner case. (Non-turbo model)
<Ref. to IN(SOHC)-6, REMOVAL, Air Cleaner Case.>
- 6) Remove the air cleaner case stay.

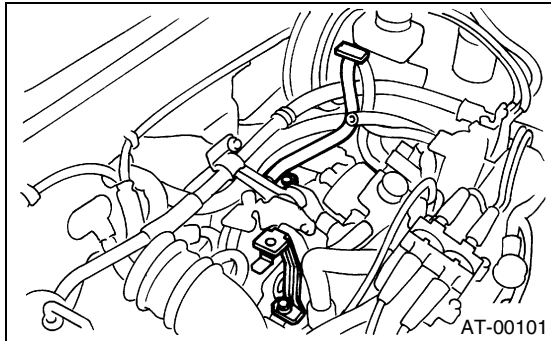

- 7) Remove the intercooler. (Turbo model)
- 8) Disconnect the following connectors.
 - (1) Transmission harness connector

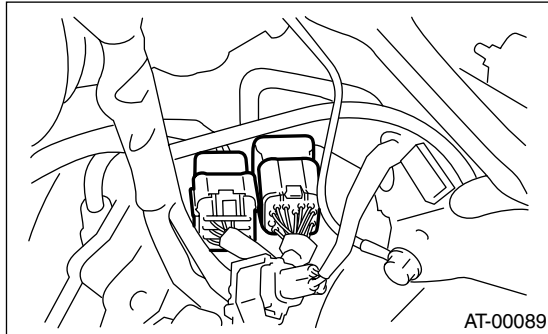

- (2) Transmission ground cable
- 9) Remove the starter.
<Ref. to SC(SOHC)-6, REMOVAL, Starter.>
- 10) Remove the pitching stopper.

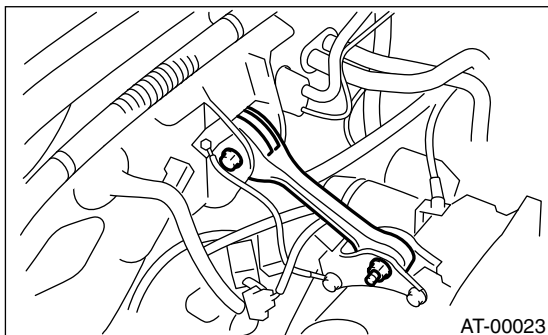

- 11) Separate the torque converter clutch from drive plate.

- (1) Remove the service hole plug.
- (2) Remove the V-belt cover.
- (3) Remove the bolts which hold torque converter clutch to drive plate.
- (4) By inserting a wrench into crank pulley bolt, rotate the crank pulley to remove other bolts.

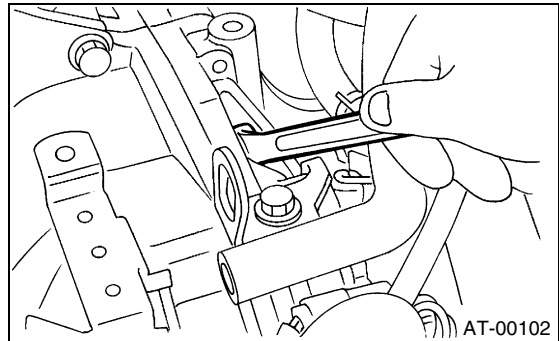

- 12) Install the ST to torque converter clutch case.
ST 498277200 STOPPER SET

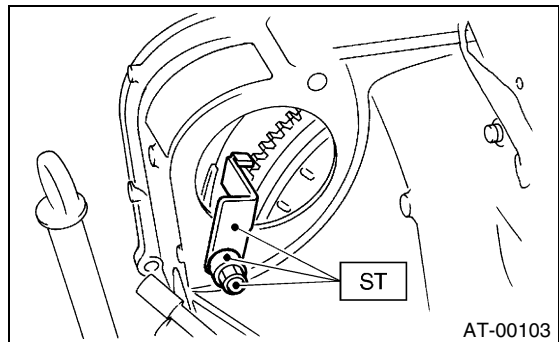

- 13) Set the ST.

NOTE:

Also the ENGINE SUPPORT BRACKET 41099AA010 can be used.

ST 41099AA020 ENGINE SUPPORT ASSY

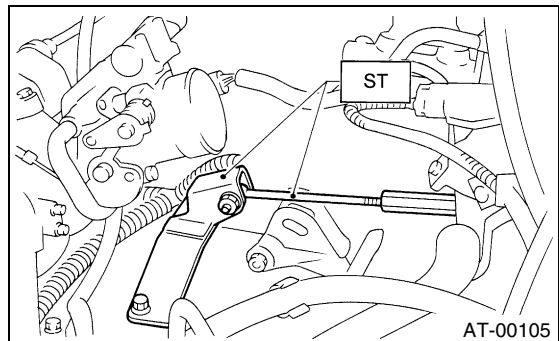

AUTOMATIC TRANSMISSION ASSEMBLY

AUTOMATIC TRANSMISSION

- 14) Remove the bolt which holds right upper side of transmission to engine.

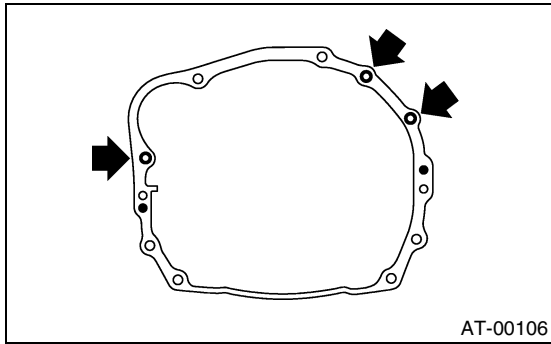

- 15) Lift-up the vehicle.
16) Remove the under cover.
17) Remove the front, center, rear exhaust pipe and muffler. (Non-turbo model) <Ref. to EX(SOHC)-7, REMOVAL, Front Exhaust Pipe.>, <Ref. to EX(SOHC)-11, REMOVAL, Rear Exhaust Pipe.> and <Ref. to EX(SOHC)-13, REMOVAL, Muffler.>
18) Remove the center, rear exhaust pipe and muffler. (Turbo model)
19) Remove the heat shield cover.
20) Remove the ATF drain plug to drain ATF.

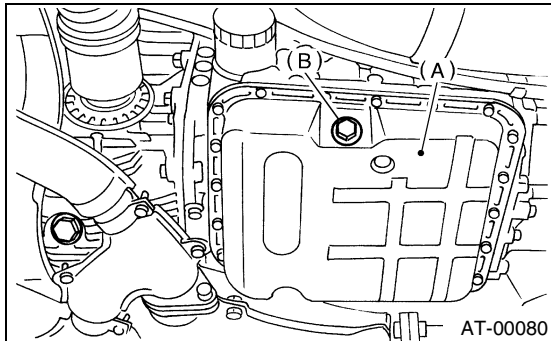

- (A) Oil pan
(B) Drain plug

- 21) Drain the differential gear oil. <Ref. to AT-30, REPLACEMENT, Differential Gear Oil.>

- 22) Disconnect the ATF cooler hoses from pipes of transmission side, and remove the ATF level gauge guide.

NOTE:

Plug the opening to prevent entry of foreign particles into transmission fluid.

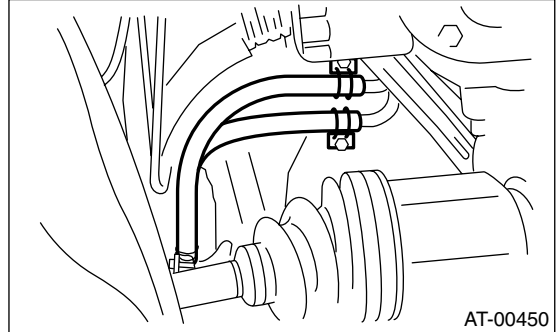

- 23) Remove the propeller shaft. <Ref. to DS-14, REMOVAL, Propeller Shaft.>
24) Remove the shift select cable. <Ref. to CS-9, REMOVAL, Select Cable.>
25) Disconnect the stabilizer link from transverse link.
26) Remove the bolt securing ball joint of transverse link to housing, and separate the transverse link from housing.

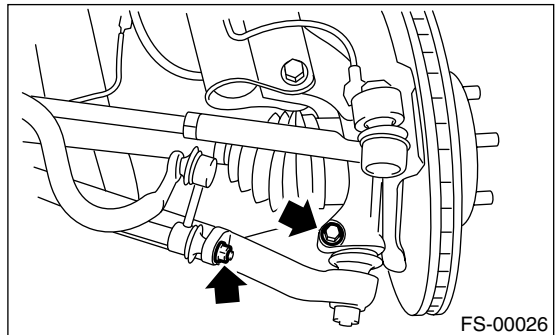

- 27) Pull the front drive shaft out of transmission.
(1) Face the "AT" letter stamped to transmission side.

ST 28399SA000 DRIVE SHAFT REMOVER

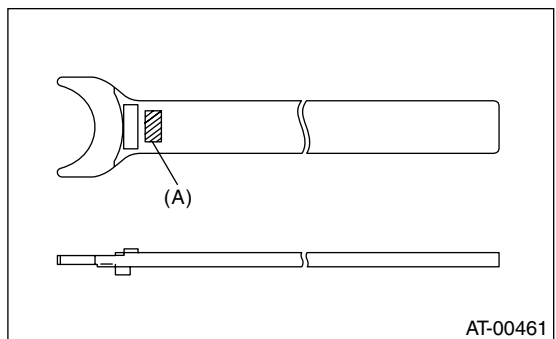

- (A) Letter "AT"

AUTOMATIC TRANSMISSION ASSEMBLY

AUTOMATIC TRANSMISSION

- (2) Insert the ST between transmission and front drive shaft.

NOTE:

Put the projection of ST on torque converter clutch housing.

ST 28399SA000 DRIVE SHAFT REMOVER

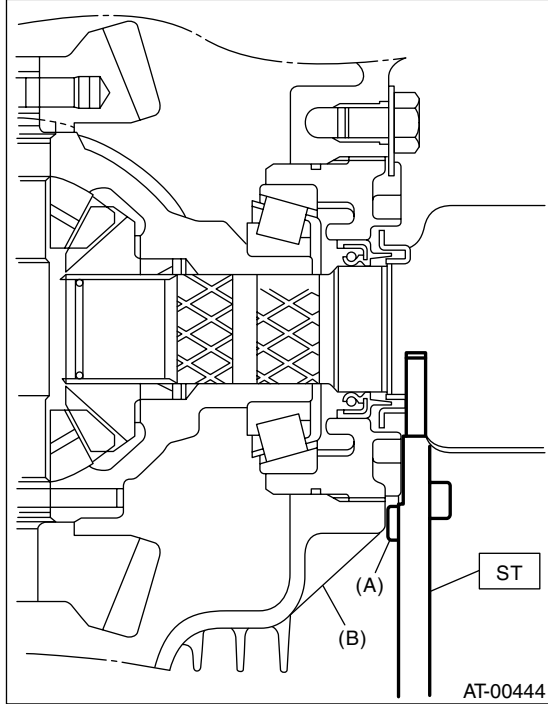

- (A) ST projection
(B) Torque converter clutch housing

- (3) While holding the joint portion (AAR) of front drive shaft with your hand, push the housing outside to prevent AAR side of boot from stretching, and then remove the front drive shaft from transmission.

- 28) Remove the nuts which hold lower side of transmission to engine.

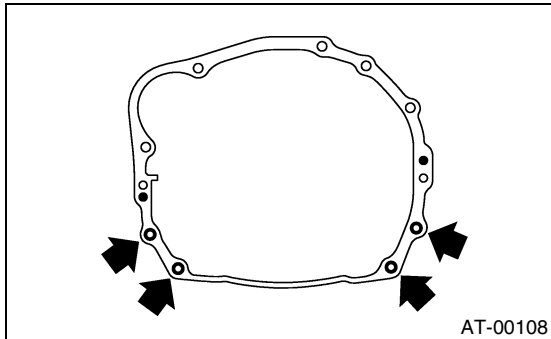

- 29) Place the transmission jack under transmission.

NOTE:

Make sure that the support plates of transmission jack do not touch the oil pan.

- 30) Remove the transmission rear crossmember from vehicle.

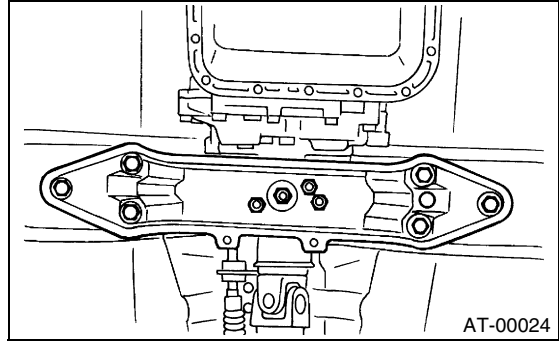

- 31) Remove the transmission.

CAUTION:

Move the transmission and torque converter as a unit away from engine.

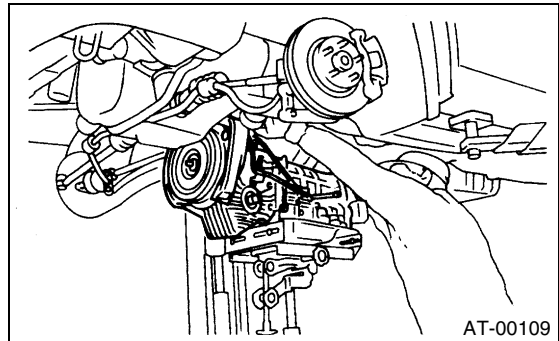

- 32) Separate the transmission assembly and rear cushion rubber.

B: INSTALLATION

- 1) Replace the differential side oil seal with a new one. <Ref. to AT-47, Differential Side Retainer Oil Seal.>
2) Install the rear cushion rubber to transmission assembly.

Tightening torque:

39 N·m (4.0 kgf·m, 29 ft·lb)

- 3) Install the ST to torque converter clutch case.
ST 498277200 STOPPER SET

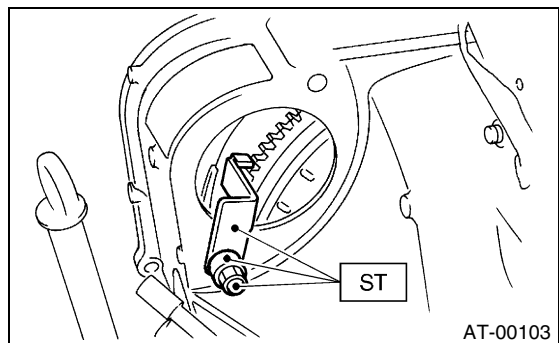

AUTOMATIC TRANSMISSION ASSEMBLY

AUTOMATIC TRANSMISSION

- 4) Install the transmission onto engine.
(1) Gradually raise the transmission with transmission jack.

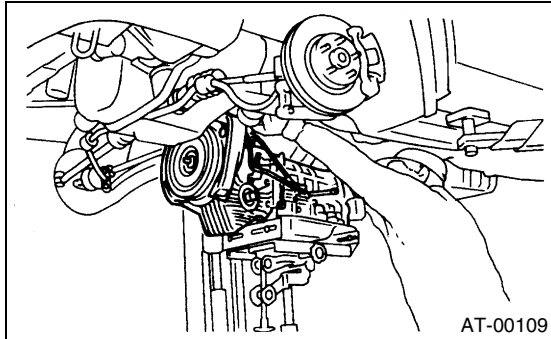

- (2) Engage them at splines.
5) Install the transmission rear crossmember.

Tightening torque:

T1: 35 N·m (3.6 kgf-m, 26 ft-lb)

T2: 70 N·m (7.1 kgf-m, 51 ft-lb)

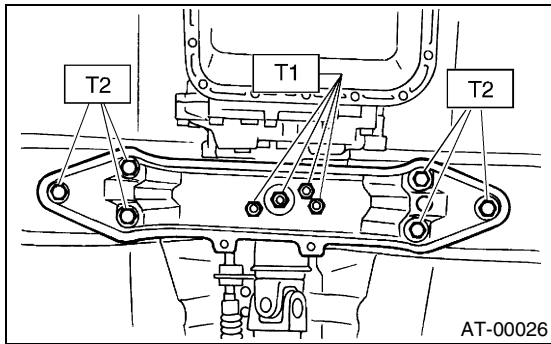

- 6) Take off the transmission jack.
7) Tighten the nuts and bolts which hold lower side of transmission to engine.

Tightening torque:

50 N·m (5.1 kgf-m, 36.9 ft-lb)

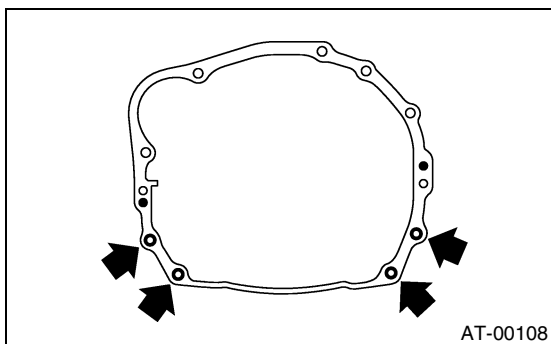

- 8) Lower the vehicle.
9) Connect the engine and transmission.
(1) Remove the ST from torque converter clutch case.

ST 498277200 STOPPER SET

- (2) Install the starter. <Ref. to SC(SOHC)-6, INSTALLATION, Starter.>

- (3) Tighten the bolt which holds upper side of transmission to engine.

Tightening torque:

50 N·m (5.1 kgf-m, 36.9 ft-lb)

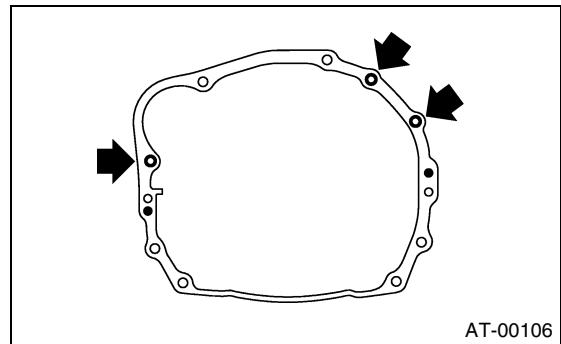

- 10) Install the torque converter clutch to drive plate.
(1) Tighten the bolts which hold torque converter clutch to drive plate.

- (2) By inserting a wrench into the crank pulley bolt, rotate the crank pulley to tighten other bolts.

Tightening torque:

25 N·m (2.5 kgf-m, 18.1 ft-lb)

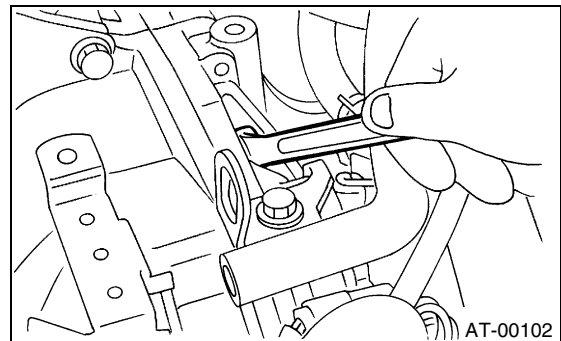

- (3) Clog the plug onto service hole.
(4) Install the V-belt cover.
11) Remove the ST.

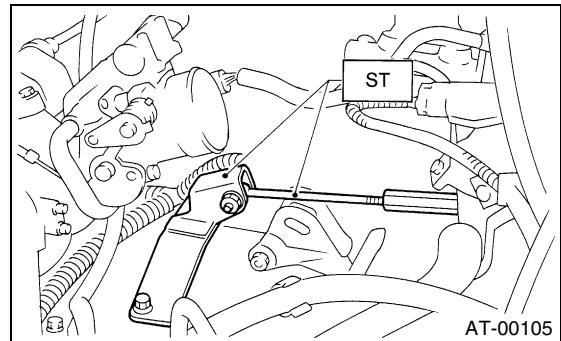

AUTOMATIC TRANSMISSION ASSEMBLY

AUTOMATIC TRANSMISSION

12) Install the pitching stopper.

Tightening torque:

T1: 50 N·m (5.1 kgf·m, 37 ft·lb)

T2: 58 N·m (5.9 kgf·m, 43 ft·lb)

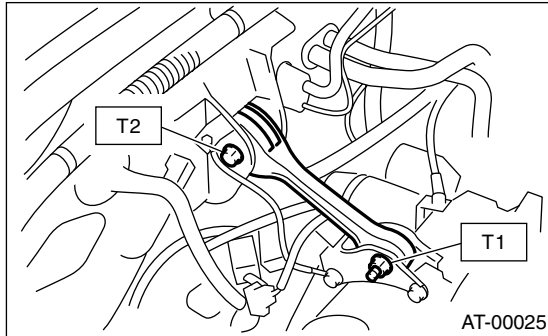

13) Lift-up the vehicle.

14) Replace the front drive shaft circlip with a new one.

15) Apply a coat grease to the lip of oil seal.

16) Install the ST to side retainer.

ST 28399SA010 OIL SEAL PROTECTOR

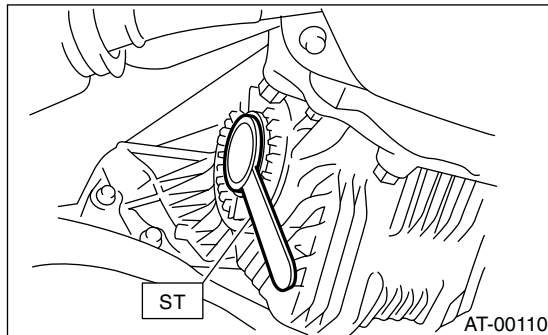

17) Insert the front drive shaft by aligning spline part of front drive shaft and spline part of differential bevel gear, and then remove the ST.

ST 28399SA010 OIL SEAL PROTECTOR

18) Insert the front drive shaft to transmission securely by pressing front housing.

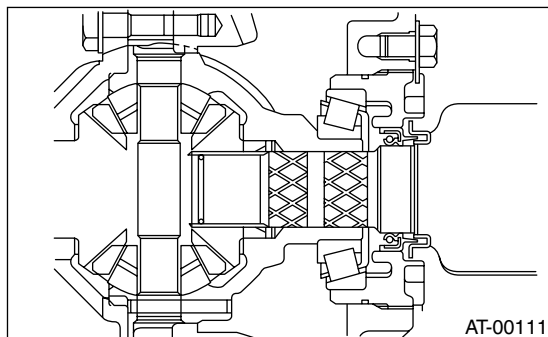

19) Connect the ball joint into housing.

20) Tighten the installing bolts.

Tightening torque:

49 N·m (5.0 kgf·m, 36 ft·lb)

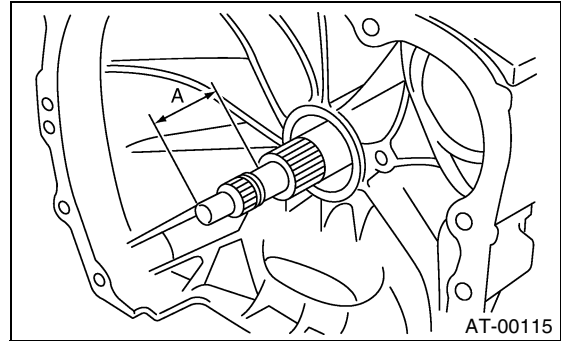

21) Install the stabilizer link from transverse link.

Tightening torque:

45 N·m (4.6 kgf·m, 33.2 ft·lb)

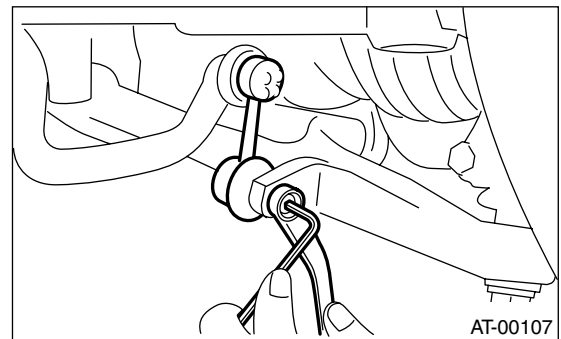

22) Install the shift select cable onto select lever. <Ref. to CS-9, INSTALLATION, Select Cable.>

23) Install the ATF level gauge guide and level gauge, and connect the ATF cooler hoses to pipe.

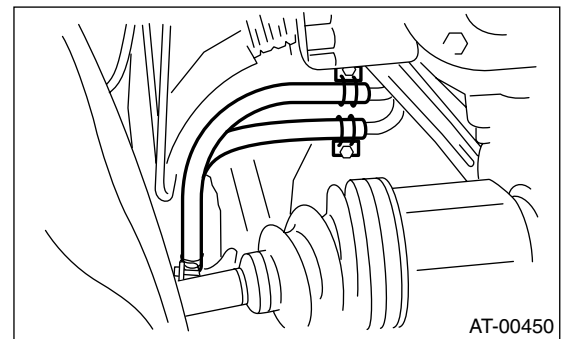

24) Install the propeller shaft. <Ref. to DS-15, INSTALLATION, Propeller Shaft.>

25) Install the heat shield cover.

26) Install the rear exhaust pipe and muffler assembly.

Non-turbo model

<Ref. to EX(SOHC)-11, INSTALLATION, Rear Exhaust Pipe.> and <Ref. to EX(SOHC)-13, INSTALLATION, Muffler.>

Turbo model

<Ref. to EX(TURBO)-12, INSTALLATION, Rear Exhaust Pipe.> and <Ref. to EX(TURBO)-14, INSTALLATION, Muffler.>

27) Install the front and center exhaust pipe. (Non-turbo model) <Ref. to EX(SOHC)-8, INSTALLATION, Front Exhaust Pipe.>

28) Install the center exhaust pipe. (Turbo model) <Ref. to EX(TURBO)-8, INSTALLATION, Center Exhaust Pipe.>

29) Install the under cover.

30) Lower the vehicle.

31) Install the ATF level gauge.

32) Connect the following connectors.

(1) Transmission harness connectors

(2) Transmission ground cable

33) Install the air cleaner case stay. (Non-turbo model)

Tightening torque:

16 N·m (1.6 kgf·m, 11.6 ft·lb)

34) Install the air cleaner case and intake duct. (Non-turbo model) <Ref. to IN(SOHC)-6, INSTALLATION, Air Cleaner Case.>, <Ref. to IN(SOHC)-7, INSTALLATION, Air Intake Duct.>

35) Install the intercooler. (Turbo model) <Ref. to IN(TURBO)-11, INSTALLATION, Intercooler.>

36) Connect the battery ground cable to battery.

37) Fill ATF up to the middle of the "COLD" side on level gauge by using the gauge hole. <Ref. to AT-29, Automatic Transmission Fluid.>

38) Fill the differential gear oil through front differential gauge hole. <Ref. to AT-30, REPLACEMENT, Differential Gear Oil.>

39) Take off the vehicle from lift arms.

40) Check the ATF level. <Ref. to AT-29, Automatic Transmission Fluid.>

41) Check the select lever operation.

<Ref. to AT-48, INSPECTION, Inhibitor Switch.>

42) Check the level of differential gear oil. <Ref. to AT-30, INSPECTION, Differential Gear Oil.>

43) Check the vehicle on the road. <Ref. to AT-31, Road Test.>

TRANSMISSION MOUNTING SYSTEM

AUTOMATIC TRANSMISSION

10. Transmission Mounting System

A: REMOVAL

1. PITCHING STOPPER

- 1) Disconnect the ground cable from battery.
- 2) Remove the air cleaner case. (Non-turbo model) <Ref. to IN(SOHC)-6, REMOVAL, Air Cleaner Case.>
- 3) Remove the intercooler. (Turbo model) <Ref. to IN(TURBO)-10, REMOVAL, Intercooler.>
- 4) Remove the pitching stopper.

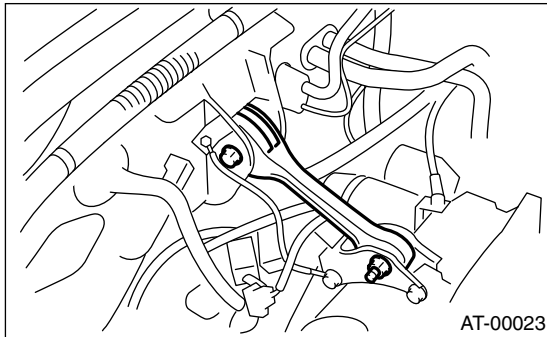

2. CROSSMEMBER AND CUSHION RUBBER

- 1) Disconnect the ground cable from battery.
- 2) Jack-up the vehicle and support it with sturdy racks.
- 3) Remove the front, center, rear exhaust pipes and muffler. (Non-turbo model) <Ref. to EX(SOHC)-7, REMOVAL, Front Exhaust Pipe.>, <Ref. to EX(SOHC)-11, REMOVAL, Rear Exhaust Pipe.> and <Ref. to EX(SOHC)-13, REMOVAL, Muffler.>
- 4) Remove the center, rear exhaust pipes and muffler. (Turbo model) <Ref. to EX(TURBO)-7, REMOVAL, Center Exhaust Pipe.>, <Ref. to EX(TURBO)-12, REMOVAL, Rear Exhaust Pipe.> and <Ref. to EX(TURBO)-14, REMOVAL, Muffler.>
- 5) Remove the heat shield cover.
- 6) Set the transmission jack under the transmission. Make sure that the support plates of transmission jack don't touch the oil pan.
- 7) Remove the transmission rear crossmember.

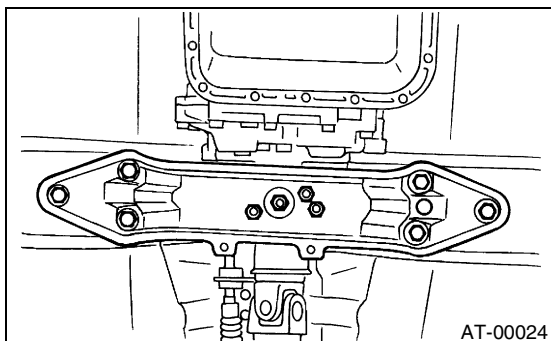

- 8) Remove the rear cushion rubber.

B: INSTALLATION

1. PITCHING STOPPER

- 1) Install the pitching stopper.

Tightening torque:

T1: 50 N·m (5.1 kgf-m, 37 ft-lb)

T2: 58 N·m (5.9 kgf-m, 43 ft-lb)

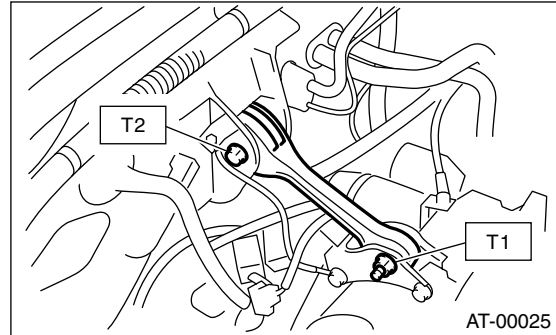

- 2) Install the air cleaner case. (Non-turbo model) <Ref. to IN(SOHC)-6, INSTALLATION, Air Cleaner Case.>

- 3) Install the intercooler. (Turbo model) <Ref. to IN(TURBO)-11, INSTALLATION, Intercooler.>

2. CROSSMEMBER AND CUSHION RUBBER

- 1) Install the rear cushion rubber.

Tightening torque:

39 N·m (4.0 kgf-m, 29 ft-lb)

- 2) Install the crossmember.

Tightening torque:

T1: 35 N·m (3.6 kgf-m, 26 ft-lb)

T2: 70 N·m (7.1 kgf-m, 51 ft-lb)

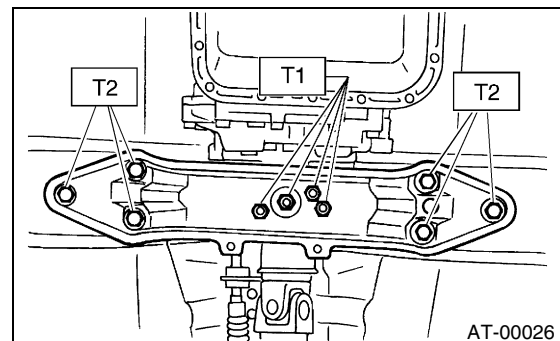

- 3) Remove the transmission jack.

- 4) Install the heat shield cover.

- 5) Install the front, center, rear exhaust pipes and the muffler. (Non-turbo model) <Ref. to EX(SOHC)-8, INSTALLATION, Front Exhaust Pipe.>, <Ref. to EX(SOHC)-11, INSTALLATION, Rear Exhaust Pipe.> and <Ref. to EX(SOHC)-13, INSTALLATION, Muffler.>

6) Install the center, rear exhaust pipes and muffler. (Turbo model) <Ref. to EX(TURBO)-8, INSTALLATION, Center Exhaust Pipe.>, <Ref. to EX(TURBO)-12, INSTALLATION, Rear Exhaust Pipe.> and <Ref. to EX(TURBO)-14, INSTALLATION, Muffler.>

C: INSPECTION

Repair or replace parts if the results of the inspection below are not satisfactory.

1. PITCHING STOPPER

Make sure that the pitching stopper is not bent or damaged. Make sure that the rubber is not stiff, cracked, or otherwise damaged.

2. CROSSMEMBER AND CUSHION RUBBER

Make sure that the crossmember is not bent or damaged. Make sure that the cushion rubber is not stiff, cracked, or otherwise damaged.

EXTENSION CASE OIL SEAL

AUTOMATIC TRANSMISSION

11. Extension Case Oil Seal

A: INSPECTION

Make sure the ATF does not leak from the joint of transmission or propeller shaft. If so, replace the oil seal. <Ref. to AT-46, REPLACEMENT, Extension Case Oil Seal.>

B: REPLACEMENT

- 1) Clean the transmission exterior.
- 2) Drain the ATF completely.
- 3) Replace the gasket with a new one, and then tighten the ATF drain plug.

Tightening torque:

25 N·m (2.5 kgf·m, 18.1 ft·lb)

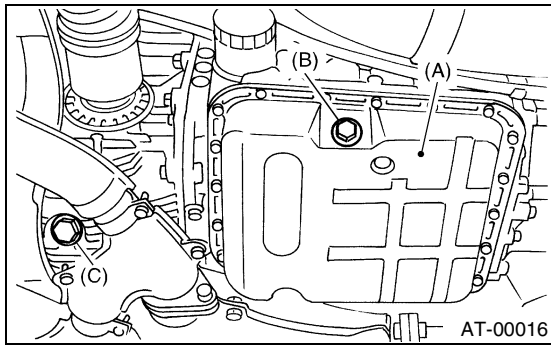

- (A) Oil pan
- (B) Drain plug
- (C) Differential oil drain plug

- 4) Remove the rear exhaust pipe and muffler.

Non-turbo model:

<Ref. to EX(SOHC)-11, REMOVAL, Rear Exhaust Pipe.> and <Ref. to EX(SOHC)-13, REMOVAL, Muffler.>

Turbo model:

<Ref. to EX(TURBO)-12, REMOVAL, Rear Exhaust Pipe.> and <Ref. to EX(TURBO)-14, REMOVAL, Muffler.>

- 5) Remove the heat shield cover.
- 6) Remove the propeller shaft. <Ref. to DS-14, REMOVAL, Propeller Shaft.>
- 7) Using the ST, remove the oil seal.
ST 398527700 PULLER ASSY
- 8) Using the ST, install the oil seal.
ST 498057300 INSTALLER
- 9) Install the propeller shaft. <Ref. to DS-15, INSTALLATION, Propeller Shaft.>
- 10) Install the heat shield cover.
- 11) Install the rear exhaust pipe and muffler.

Non-turbo model:

<Ref. to EX(SOHC)-11, INSTALLATION, Rear Exhaust Pipe.> and <Ref. to EX(SOHC)-13, INSTALLATION, Muffler.>

Turbo model:

<Ref. to EX(TURBO)-12, INSTALLATION, Rear Exhaust Pipe.> and <Ref. to EX(TURBO)-14, INSTALLATION, Muffler.>

12) Pour ATF and check the ATF level. <Ref. to AT-29, Automatic Transmission Fluid.>

DIFFERENTIAL SIDE RETAINER OIL SEAL

AUTOMATIC TRANSMISSION

12. Differential Side Retainer Oil Seal

A: INSPECTION

Make sure the gear oil dose not leak from differential side retainer oil seal part.
If oil leaks, replace the oil seal.

B: REPLACEMENT

- 1) Lift-up the vehicle.
- 2) Remove the front exhaust pipe and center exhaust pipes. (Non-turbo model)
<Ref. to EX(SOHC)-7, REMOVAL, Front Exhaust Pipe.>
- 3) Remove the differential oil drain plug, and then drain the differential gear oil.

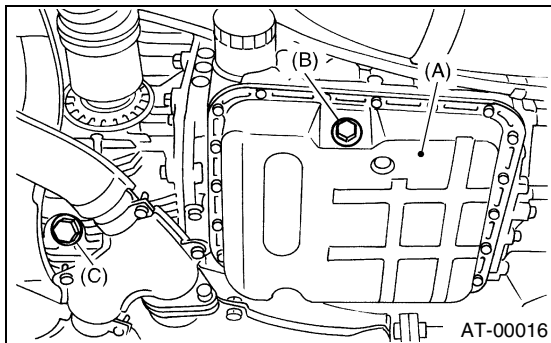

- (A) Oil pan
- (B) ATF drain plug
- (C) Differential gear oil drain plug

- 4) Replace the gasket with a new one, and then tighten the differential oil drain plug.

Tightening torque:

44 N·m (4.5 kgf·m, 32.5 ft·lb)

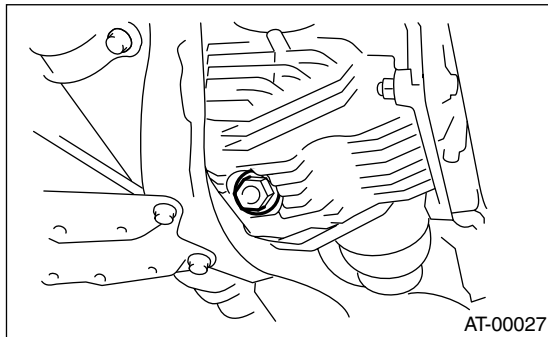

- 5) Separate the front drive shaft from transmission.
<Ref. to DS-31, REMOVAL, Front Drive Shaft.>

- 6) Using a vinyl tape wrapped flat tip screwdriver, remove the differential side retainer oil seal.

- 7) Using the ST, install the differential side retainer oil seal tapping ST lightly with a hammer.

ST 18675AA000 DIFFERENTIAL SIDE OIL SEAL INSTALLER

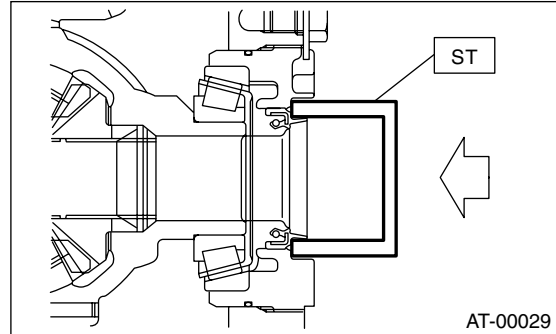

- 8) Apply a coat of oil to the oil seal lip.
- 9) Install the front drive shaft. <Ref. to DS-32, INSTALLATION, Front Drive Shaft.>
- 10) Lower the vehicle.
- 11) Fill the gear oil through gauge hole.

Recommend gear oil:

GL-5 (SAE: 80W — 90) or equivalent

Gear oil capacity:

1.1 — 1.3 ℓ (1.3 — 1.4 US qt, 1.0 — 1.1 Imp qt)

- 12) Check the gear oil level. <Ref. to AT-30, INSPECTION, Differential Gear Oil.>

INHIBITOR SWITCH

AUTOMATIC TRANSMISSION

13. Inhibitor Switch

A: INSPECTION

When the driving condition or starter motor operation is erroneous, first check the shift linkage for improper operation. If the shift linkage is functioning properly, check the inhibitor switch.

- 1) Disconnect the inhibitor switch connector.
 - 2) Check continuity in inhibitor switch circuits with the select lever moved to each position.
- Also check that continuity in ignition circuit does not exist when the select lever is in "R", "D", "3", "2" and "1" ranges.

If the inhibitor switch is inoperative, check for poor contact of connector on transmission side.

	Position	Pin No.	Value
Signal sent to TCM	P	4 — 3	Less than 1Ω
	R	4 — 2	
	N	4 — 1	
	D	4 — 8	
	3	4 — 7	
	2	4 — 6	
	1	4 — 5	
Ignition circuit	P/N	12 — 11	
Back-up light circuit	R	10 — 9	

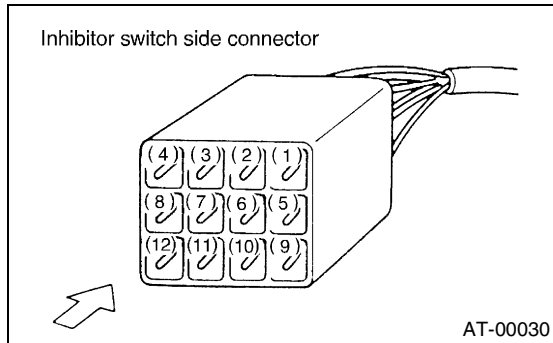

- 3) Check if there is continuity at equal points when the select lever is turned 1.5° in both directions from "N" range.

If there is continuity in one direction and the continuity in the other or if there is continuity at unequal points, adjust the inhibitor switch. <Ref. to AT-48, ADJUSTMENT, Inhibitor Switch.>

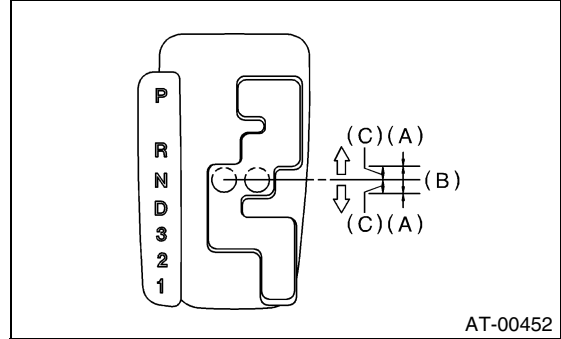

- (A) Continuity does not exist.
- (B) Continuity exists.
- (C) 1.5°

- 4) Repeat the above checks. If there are abnormalities, adjust the select cable. <Ref. to CS-10, ADJUSTMENT, Select Cable.>

B: ADJUSTMENT

- 1) Shift the select lever to "N" range.
- 2) Loosen the three inhibitor switch securing bolts.
- 3) Insert the ST as vertical as possible into the holes in inhibitor switch lever and switch body.
ST 499267300 STOPPER PIN

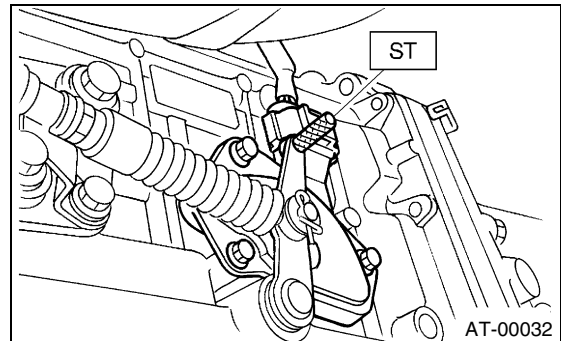

- 4) Tighten the three inhibitor switch bolts.

Tightening torque:

3.5 N·m (0.35 kgf·m, 2.5 ft·lb)

- 5) Repeat the above checks. If the inhibitor switch is determined to be "faulty", replace it.

C: REMOVAL

- 1) Set the vehicle on a lift.
- 2) Move the select lever to "N" range.
- 3) Remove the air cleaner case. (Non-turbo model)
<Ref. to IN(SOHC)-6, REMOVAL, Air Cleaner Case.>
- 4) Remove the intercooler. (Turbo model) <Ref. to IN(TURBO)-10, REMOVAL, Intercooler.>
- 5) Disconnect the inhibitor switch connector.

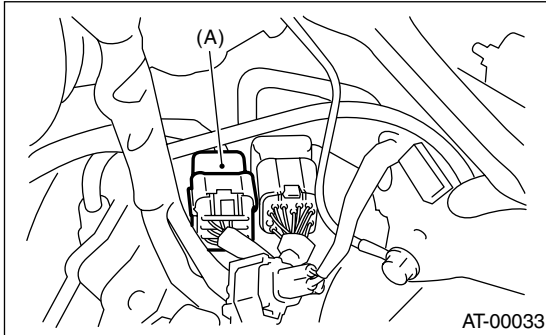

(A) Inhibitor switch

- 6) Remove the inhibitor switch connector from stay.
- 7) Lift-up the vehicle.
- 8) Remove the front and center exhaust pipes. (Non-turbo model)
<Ref. to EX(SOHC)-7, REMOVAL, Front Exhaust Pipe.>
- 9) Remove the center exhaust pipe. (Turbo model)
<Ref. to EX(TURBO)-7, REMOVAL, Center Exhaust Pipe.>
- 10) Remove the snap pin and washer from range select lever.

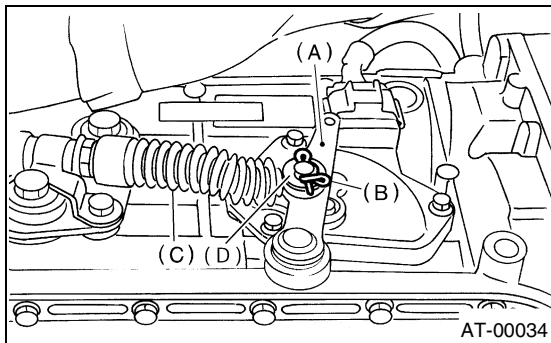

- (A) Range select lever
- (B) Snap pin
- (C) Select cable
- (D) Washer

- 11) Remove the plate assembly from transmission case.

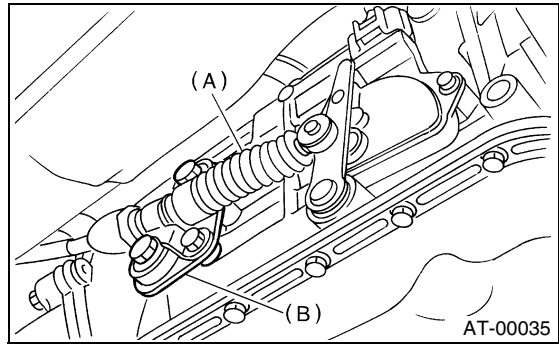

- (A) Select cable
- (B) Plate ASSY

- 12) Remove the bolts.

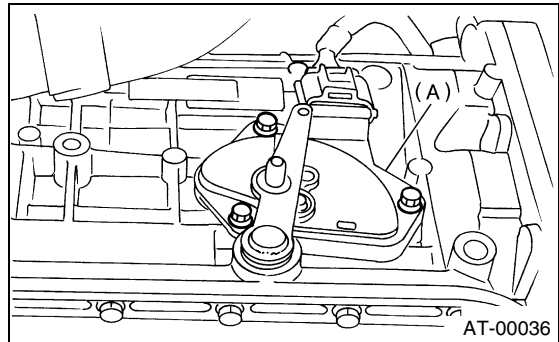

(A) Inhibitor switch

- 13) Move the range select lever to parking position (left side).

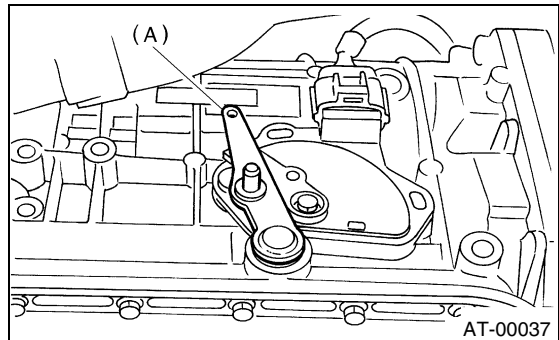

(A) Range select lever

INHIBITOR SWITCH

AUTOMATIC TRANSMISSION

14) Remove the inhibitor switch from transmission.

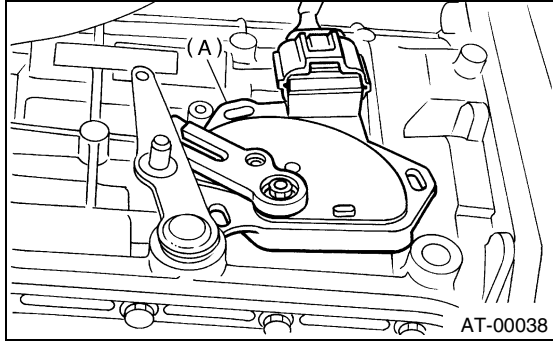

(A) Inhibitor switch

15) Disconnect the inhibitor switch harness connector from inhibitor switch.

D: INSTALLATION

1) Connect the inhibitor switch harness connector to inhibitor switch.

2) Install the inhibitor switch to transmission case.

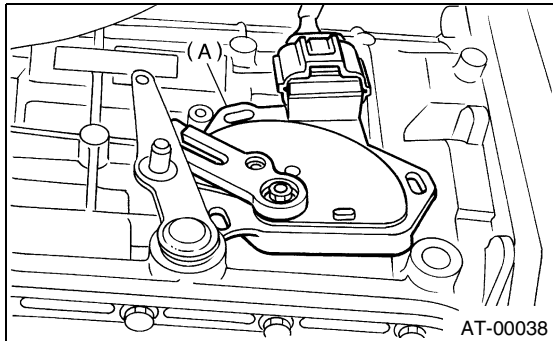

(A) Inhibitor switch

3) Move the range select lever to neutral position.
4) Place the inhibitor switch on specified position, and then tighten the bolts for inhibitor switch using ST.

ST 499267300 STOPPER PIN

Tightening torque:

3.5 N·m (0.36 kgf-m, 2.6 ft-lb)

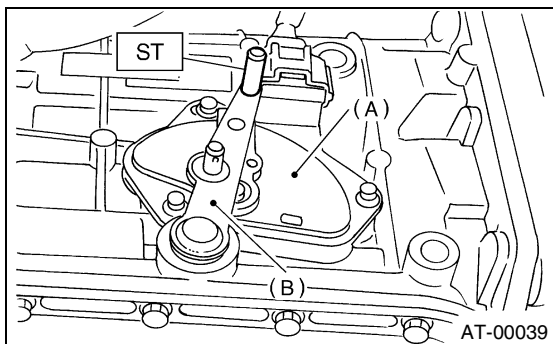

(A) Inhibitor switch
(B) Range select lever

5) Install the select cable to range select lever.

6) Install the plate assembly to transmission.

Tightening torque:

T: 25 N·m (2.5 kgf-m, 18.1 ft-lb)

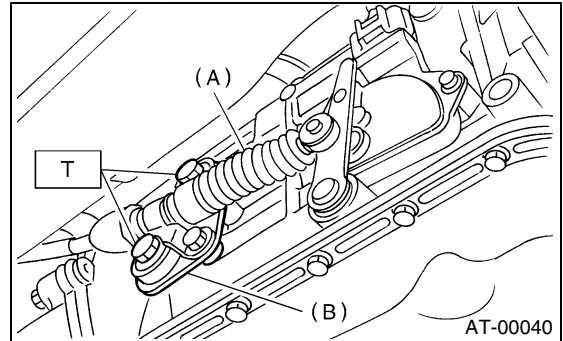

(A) Select cable
(B) Plate ASSY

7) Install the washer and snap pin to range select lever.

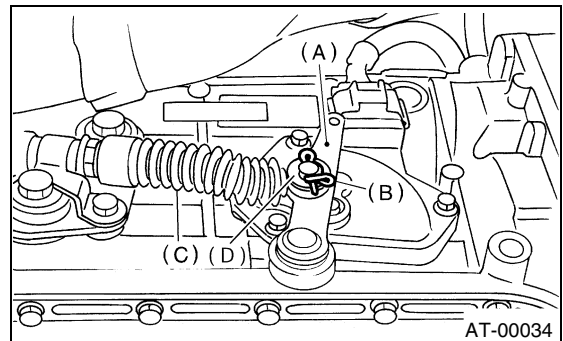

(A) Range select lever
(B) Snap ring
(C) Select cable
(D) Washer

8) Install the front and center exhaust pipes. (Non-turbo model) <Ref. to EX(SOHC)-8, INSTALLATION, Front Exhaust Pipe.>

9) Install the center exhaust pipe. (Turbo model) <Ref. to EX(TURBO)-8, INSTALLATION, Center Exhaust Pipe.>

10) Lower the vehicle.

11) Install the inhibitor switch connector to stay.

12) Connect the inhibitor switch connector.

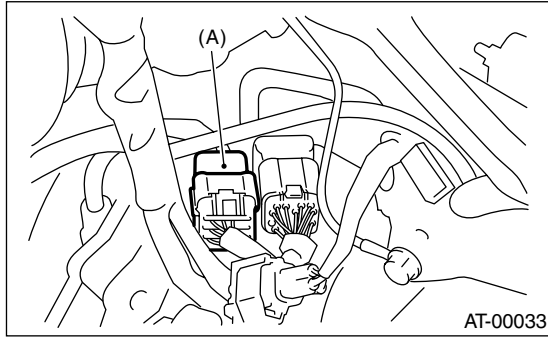

(A) Inhibitor switch

13) Install the air cleaner case. (Non-turbo model)
<Ref. to IN(SOHC)-6, INSTALLATION, Air Cleaner Case.>

14) Install the intercooler. (Turbo model) <Ref. to IN(TURBO)-11, INSTALLATION, Intercooler.>

15) Inspect the inhibitor switch. <Ref. to AT-48, INSPECTION, Inhibitor Switch.>

FRONT VEHICLE SPEED SENSOR

AUTOMATIC TRANSMISSION

14. Front Vehicle Speed Sensor

A: REMOVAL

- 1) Set the vehicle on a lift.
- 2) Disconnect the ground cable from battery.

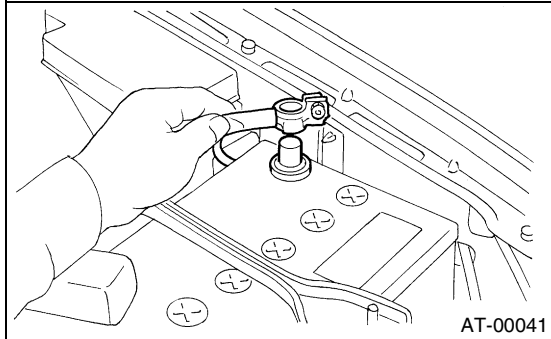

- 3) Remove the air cleaner case. (Non-turbo model) <Ref. to IN(SOHC)-6, REMOVAL, Air Cleaner Case.>
- 4) Remove the intercooler. (Turbo model) <Ref. to IN(TURBO)-10, REMOVAL, Intercooler.>
- 5) Disconnect the transmission connector.

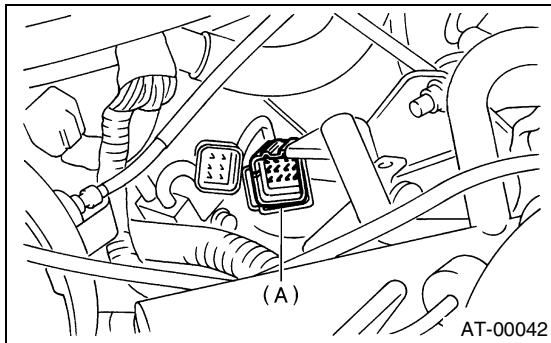

(A) Transmission connector

- 6) Remove the pitching stopper. <Ref. to AT-44, REMOVAL, Transmission Mounting System.>
- 7) Remove the transmission connector from stay.
- 8) Lift-up the vehicle.
- 9) Clean the transmission exterior.

- 10) Drain the ATF completely.

NOTE:

- Tighten the ATF drain plug after draining the ATF.
- Replace the gasket with a new one.

Tightening torque:

25 N·m (2.5 kgf·m, 18.1 ft·lb)

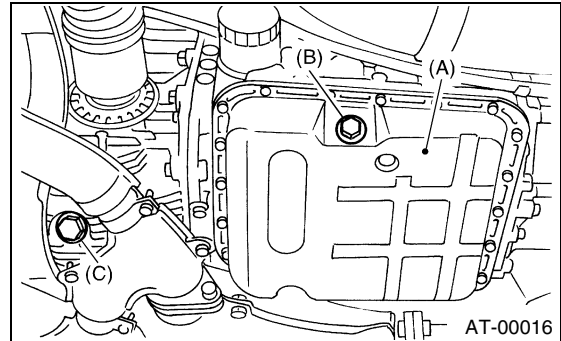

- (A) Oil pan
- (B) Drain plug
- (C) Differential oil drain plug

- 11) Remove the front, center, exhaust pipes and muffler. (Non-turbo model) <Ref. to EX(SOHC)-7, REMOVAL, Front Exhaust Pipe.>, <Ref. to EX(SOHC)-11, REMOVAL, Rear Exhaust Pipe.> and <Ref. to EX(SOHC)-13, REMOVAL, Muffler.>

- 12) Remove the center, rear exhaust pipes and muffler. (Turbo model) <Ref. to EX(TURBO)-7, REMOVAL, Center Exhaust Pipe.>, <Ref. to EX(TURBO)-12, REMOVAL, Rear Exhaust Pipe.> and <Ref. to EX(TURBO)-14, REMOVAL, Muffler.>
- 13) Remove the shield cover.

- 14) Remove the propeller shaft. <Ref. to DS-14, REMOVAL, Propeller Shaft.>

- 15) Place the transmission jack under transmission.

NOTE:

Make sure that the support plates of transmission jack don't touch the crossmember.

- 16) Remove the transmission rear crossmember bolts.

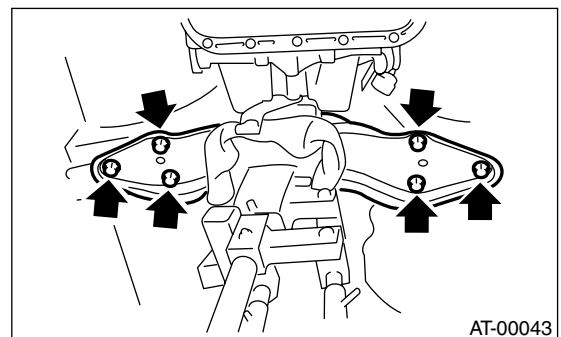

FRONT VEHICLE SPEED SENSOR

AUTOMATIC TRANSMISSION

17) Lower the AT jack.

NOTE:

Do not separate the AT jack and transmission.

18) Remove the oil cooler inlet and outlet pipe.

NOTE:

When removing the outlet pipe, be careful not to lose balls and springs used with retaining screws.

19) Remove the front torque converter turbine speed sensor.

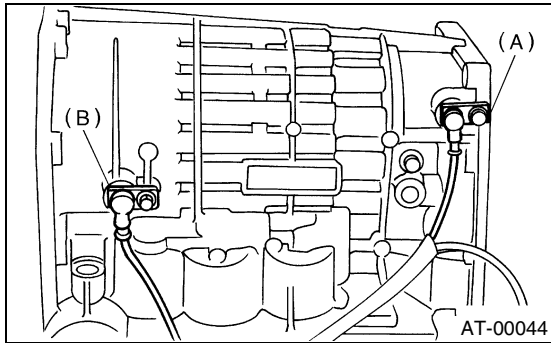

- (A) Front vehicle speed sensor
- (B) Torque converter turbine speed sensor

20) Remove the rear vehicle speed sensor.

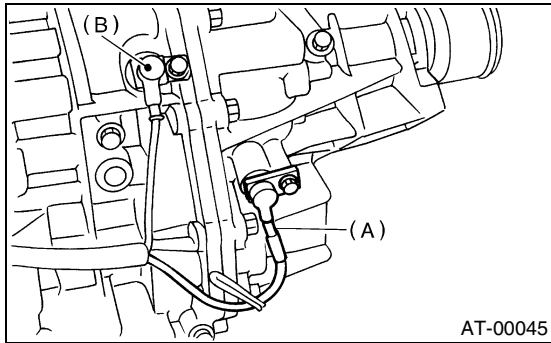

- (A) Rear vehicle speed sensor
- (B) Front vehicle speed sensor

21) Remove the oil pan.

22) Disconnect the duty solenoids and ATF temperature sensor connectors. Remove the connectors from clip and disconnect the connectors.

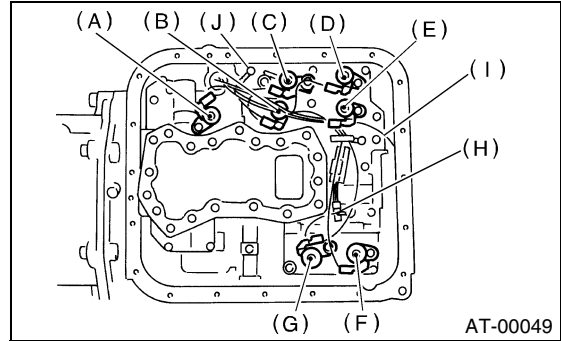

- (A) Lock-up duty solenoid (Blue)
- (B) Low clutch timing solenoid (Gray)
- (C) Line pressure duty solenoid (Red)
- (D) Shift solenoid 2 (Yellow)
- (E) Shift solenoid 1 (Green)
- (F) 2-4 brake timing solenoid (Black)
- (G) 2-4 brake duty solenoid (Red)
- (H) ATF temperature sensor
- (I) Transfer duty solenoid (Brown)
- (J) Transmission ground

23) Remove the harness assembly.

B: INSTALLATION

1) Pass the harness assembly through the hole in the transmission case.

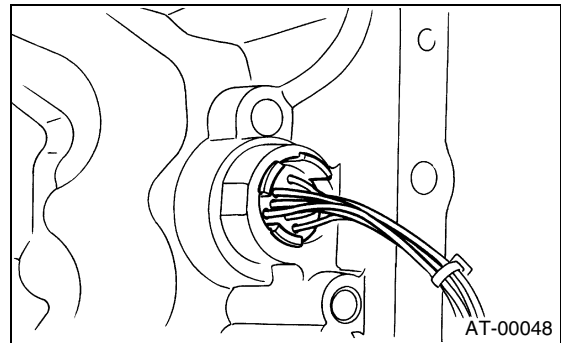

FRONT VEHICLE SPEED SENSOR

AUTOMATIC TRANSMISSION

2) Connect the harness connectors. Connect the connectors of same color, and secure the connectors to valve body using clips.

Tightening torque (Transmission ground cable)
8 N·m (0.8 kgf·m, 5.8 ft·lb)

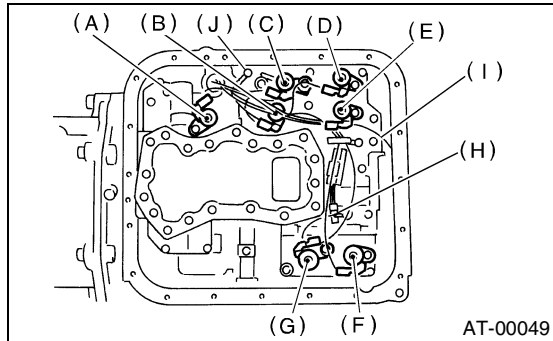

- (A) Lock-up duty solenoid (Blue)
- (B) Low clutch timing solenoid (Gray)
- (C) Line pressure duty solenoid (Red)
- (D) Shift solenoid 2 (Yellow)
- (E) Shift solenoid 1 (Green)
- (F) 2-4 brake timing solenoid (Black)
- (G) 2-4 brake duty solenoid (Red)
- (H) ATF temperature sensor
- (I) Transfer duty solenoid (Brown)
- (J) Transmission ground

3) Apply proper amount of liquid gasket to the entire oil pan mating surface.

Fluid packing:
THREE BOND 1217B (Part No. K0877YA020)

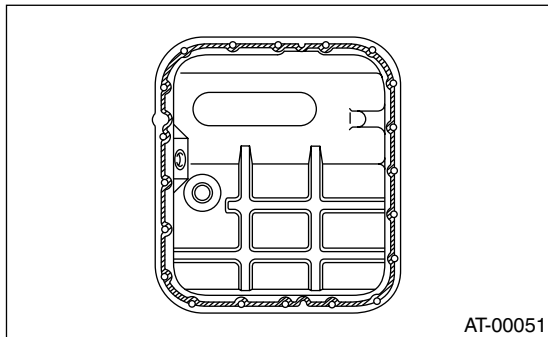

4) Apply liquid gasket fully to the three holes other than screw holes on transmission case.

Fluid packing:
THREE BOND 1217B (Part No. K0877YA020)

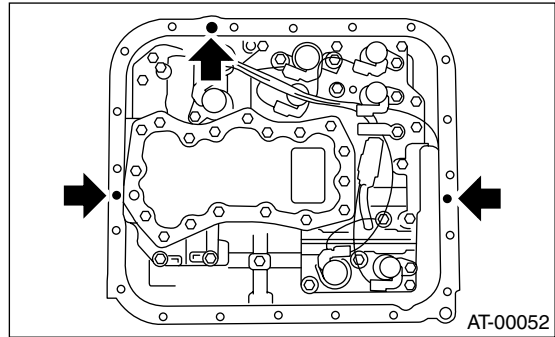

5) Install the oil pan.

Tightening torque:
5 N·m (0.5 kgf·m, 3.6 ft·lb)

6) Install the front and rear vehicle speed sensor, and also the torque converter turbine speed sensor, and then fasten the harness.

Tightening torque:
7 N·m (0.7 kgf·m, 5.1 ft·lb)

7) Install a new aluminum washer and oil cooler pipes.

Tightening torque:
T1: 25 N·m (2.5 kgf·m, 18.1 ft·lb)
T2: 44 N·m (4.5 kgf·m, 32.5 ft·lb)

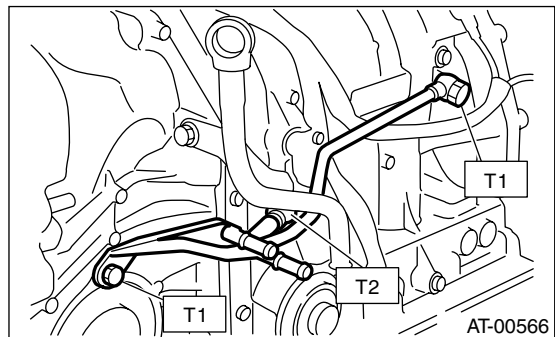

8) Install the transmission rear crossmember bolts.

Tightening torque:
70 N·m (7.1 kgf·m, 51 ft·lb)

9) Install the propeller shaft. <Ref. to DS-15, INSTALLATION, Propeller Shaft.>

10) Install the shield cover.

11) Install the front, center, rear exhaust pipes and muffler. (Non-turbo model)

<Ref. to EX(SOHC)-8, INSTALLATION, Front Exhaust Pipe.>, <Ref. to EX(SOHC)-11, INSTALLATION, Rear Exhaust Pipe.> and <Ref. to EX(SOHC)-13, INSTALLATION, Muffler.>

12) Install the center, rear exhaust pipes and muffler. (Turbo model) <Ref. to EX(TURBO)-8, INSTALLATION, Center Exhaust Pipe.>, <Ref. to EX(TURBO)-12, INSTALLATION, Rear Exhaust Pipe.> and <Ref. to EX(TURBO)-14, INSTALLATION, Muffler.>

13) Lower the vehicle.

14) Install the transmission connector to the stay.

15) Install the pitching stopper. <Ref. to AT-44, INSTALLATION, Transmission Mounting System.>

16) Install the air cleaner case. (Non-turbo model) <Ref. to IN(SOHC)-6, INSTALLATION, Air Cleaner Case.>

17) Install the intercooler. (Turbo model) <Ref. to IN(TURBO)-11, INSTALLATION, Intercooler.>

15.Rear Vehicle Speed Sensor

A: REMOVAL

When removing the rear vehicle speed sensor, refer to “Front Vehicle Speed Sensor.” <Ref. to AT-52, REMOVAL, Front Vehicle Speed Sensor.>

B: INSTALLATION

When installing the rear vehicle speed sensor, refer to “Front Vehicle Speed Sensor.” <Ref. to AT-53, INSTALLATION, Front Vehicle Speed Sensor.>

16. Torque Converter Turbine Speed Sensor

A: REMOVAL

When removing the torque converter turbine speed sensor, refer to "Front Vehicle Speed Sensor."
<Ref. to AT-52, REMOVAL, Front Vehicle Speed Sensor.>

B: INSTALLATION

When installing the torque converter turbine speed sensor, refer to "Front Vehicle Speed Sensor."
<Ref. to AT-53, INSTALLATION, Front Vehicle Speed Sensor.>

CONTROL VALVE BODY

AUTOMATIC TRANSMISSION

17. Control Valve Body

A: REMOVAL

- 1) Lift-up the vehicle.
- 2) Clean the transmission exterior.
- 3) Drain the ATF completely.

NOTE:

- Tighten the ATF drain plug after draining the ATF.
- Replace the gasket with a new one.

Tightening torque:

25 N·m (2.5 kgf-m, 18.1 ft-lb)

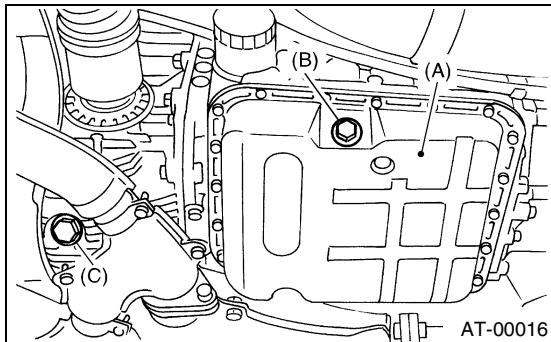

- (A) Oil pan
- (B) Drain plug
- (C) Differential oil drain plug

- 4) Remove the oil pan.
- 5) Remove and clean the magnet.
- 6) Remove the old gasket on the oil pan and transmission case completely.

- 7) Disconnect the duty solenoids and ATF temperature sensor connectors. Remove the connectors from clip and disconnect the connectors.

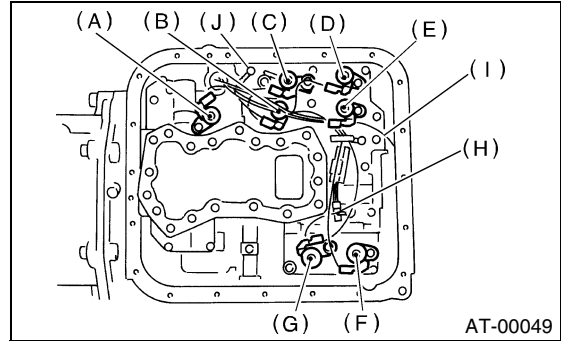

- (A) Lock-up duty solenoid (Blue)
- (B) Low clutch timing solenoid (Gray)
- (C) Line pressure duty solenoid (Red)
- (D) Shift solenoid 2 (Yellow)
- (E) Shift solenoid 1 (Green)
- (F) 2-4 brake timing solenoid (Black)
- (G) 2-4 brake duty solenoid (Red)
- (H) ATF temperature sensor
- (I) Transfer duty solenoid (Brown)
- (J) Transmission ground

- 8) Remove the control valve.

NOTE:

When removing the control valve body, be careful not to interfere with transfer duty solenoid wiring.

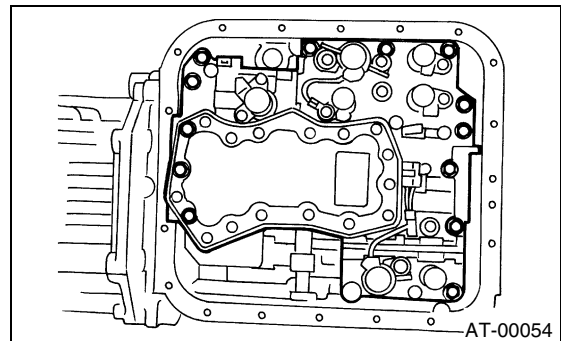

B: INSTALLATION

- 1) Set the range select lever in "N" range.
- 2) Install the control valve and ground connectors.

Tightening torque:

8 N·m (0.8 kgf·m, 5.8 ft·lb)

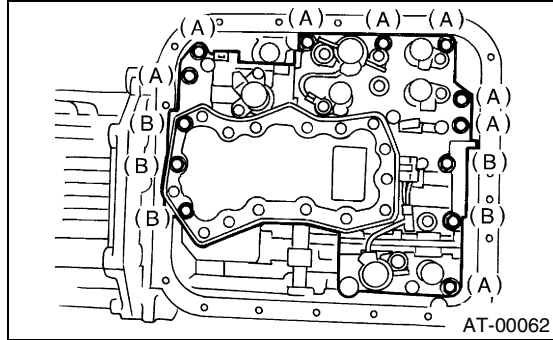

Bolt length mm (in)

(A) 30 (1.18)

(B) 55 (2.17)

- 3) Connect all connectors.

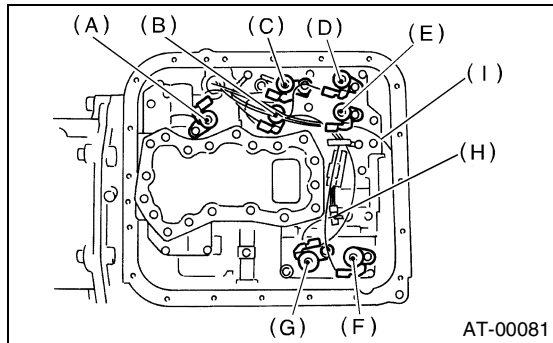

- (A) Lock-up duty solenoid (Blue)
- (B) Low clutch timing solenoid (Gray)
- (C) Line pressure duty solenoid (Red)
- (D) Shift solenoid 2 (Yellow)
- (E) Shift solenoid 1 (Green)
- (F) 2-4 brake timing solenoid (Black)
- (G) 2-4 brake duty solenoid (Red)
- (H) ATF temperature sensor
- (I) Transfer duty solenoid (Brown)

- 4) Attach the magnet at specified position.

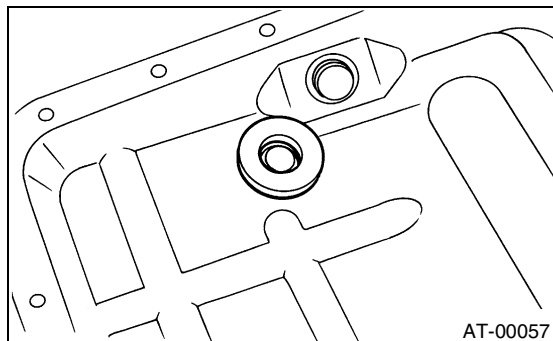

- 5) Apply proper amount of liquid gasket to the entire oil pan mating surface.

Liquid gasket:

THREE BOND 1217B (Part No. K0877YA020)

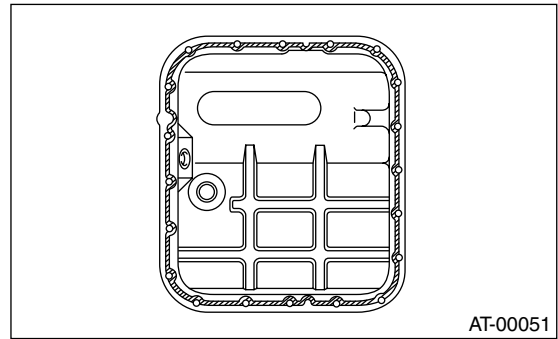

- 6) Apply liquid gasket fully to three holes other than screw holes on transmission case.

Liquid gasket:

THREE BOND 1217B (Part No. K0877YA020)

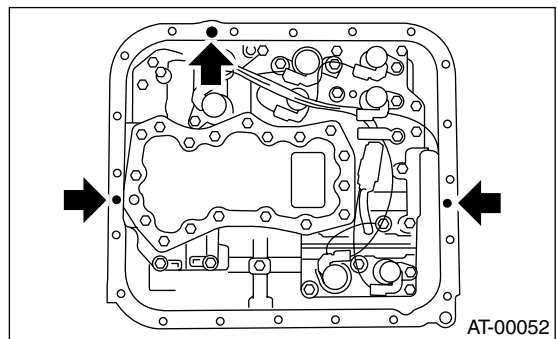

- 7) Install the oil pan.

Tightening torque:

5 N·m (0.5 kgf·m, 3.6 ft·lb)

- 8) Pour ATF into the oil charge pipe.

Recommended fluid:

Dexron III type automatic transmission fluid

Fluid capacity:

Fill the same amount of fluid drained from drain plug hole.

- 9) Check the level of ATF.

<Ref. to AT-29, Automatic Transmission Fluid.>

CONTROL VALVE BODY

AUTOMATIC TRANSMISSION

C: DISASSEMBLY

1) Remove the oil strainer from lower control valve body.

NOTE:

Arrange the removed bolts in good order to assemble in the same place as disassembly, because the bolts length are different.

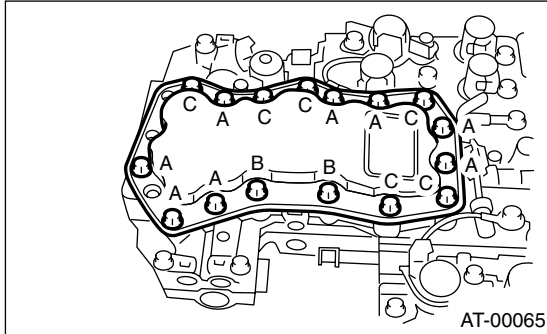

- (A) Short bolt
- (B) Middle bolt
- (C) Long bolt

2) Remove the duty solenoids, solenoids and sensor from the lower valve body.

NOTE:

Arrange the removed bolts in good order to assemble in the same place as disassembly, because the bolts length are different.

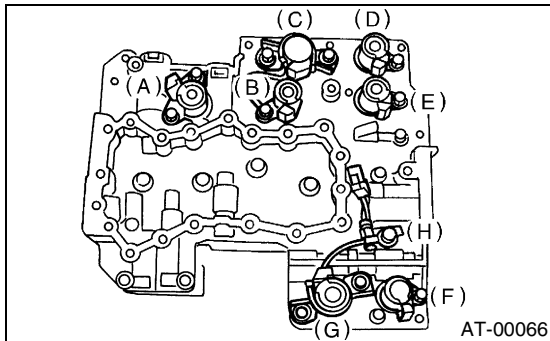

- (A) Lock-up duty solenoid (Blue)
- (B) Low clutch timing solenoid (Gray)
- (C) Line pressure duty solenoid (Red)
- (D) Shift solenoid 1 (Yellow)
- (E) Shift solenoid 2 (Green)
- (F) 2-4 brake timing solenoid (Black)
- (G) 2-4 brake duty solenoid (Red)
- (H) ATF temperature sensor

3) Remove the upper-lower valve body tightening bolts.

NOTE:

Arrange the removed bolts in good order to assemble in the same place as disassembly, because the bolts length are different.

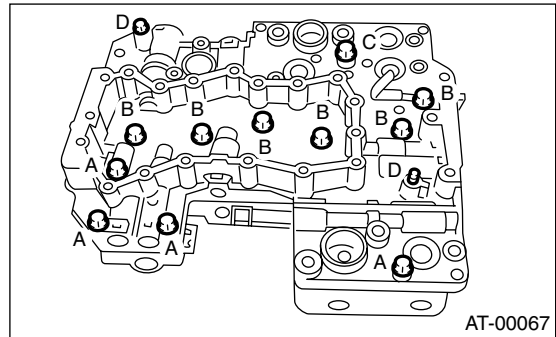

4) Remove the lower valve body.
5) Remove the oil filter and plate.

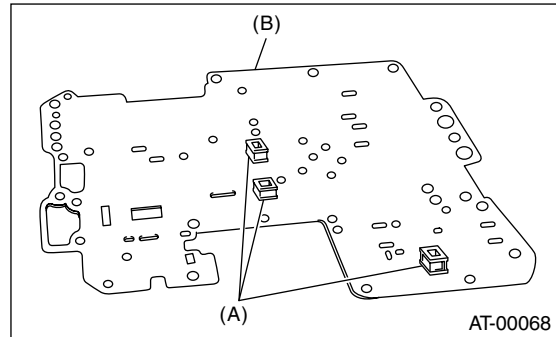

- (A) Oil filter
- (B) Plate

6) Remove the six steel balls from middle valve body.

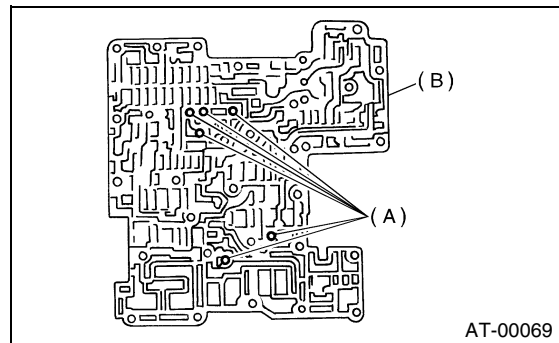

- (A) Steel ball
- (B) Middle valve body

7) Remove the middle valve body.

8) Remove the upper separator plate from middle valve body.

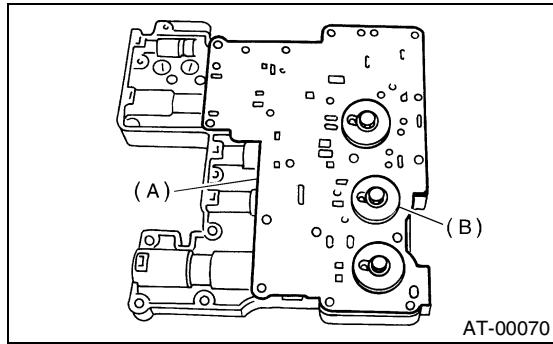

- (A) Upper separator plate
- (B) Side plate

9) Remove the valve springs and four steel balls from upper valve body.

10) Place a shop cloth to the piston removal hole.

11) Using an air compressor, apply air slowly to each piston hole and remove the pistons.

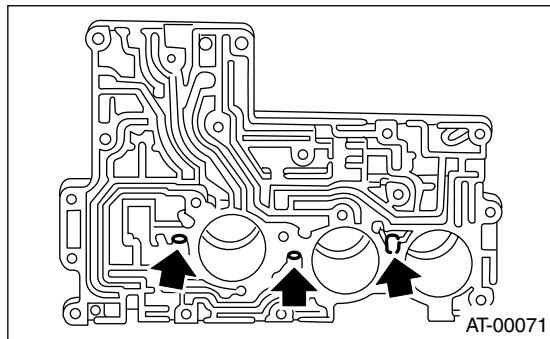

12) Remove the seal ring from piston.

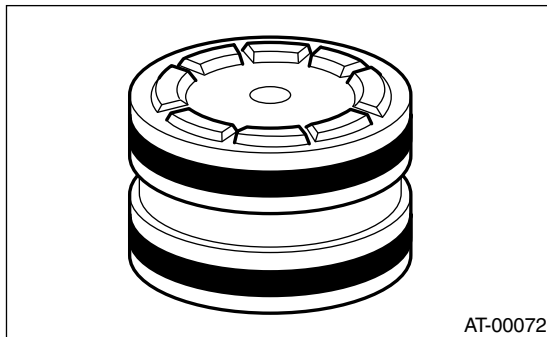

D: ASSEMBLY

1) Install a new seal ring to piston.

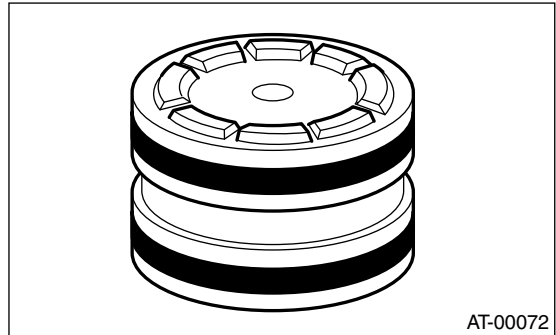

2) Apply ATF to the seal ring.

3) Insert the piston fully into upper valve body.

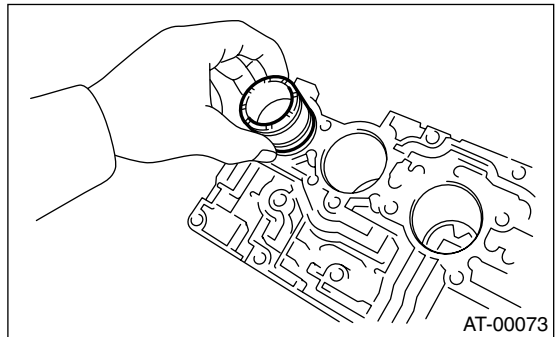

4) Install the spring and four steel balls to specified positions of upper valve body.

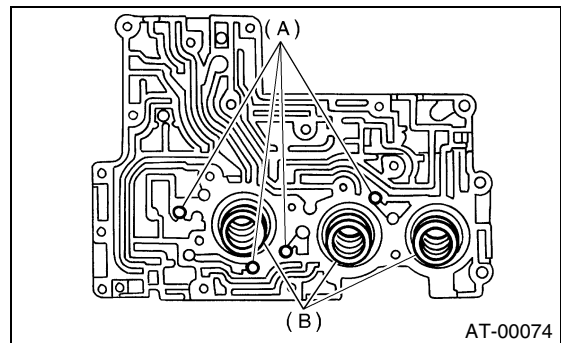

- (A) Steel ball
- (B) Spring

CONTROL VALVE BODY

AUTOMATIC TRANSMISSION

5) Align the hole in side plate with the hole in separator plate, and then install the support plate and upper separator plate to middle valve body.

Tightening torque:

8 N·m (0.8 kgf·m, 5.8 ft·lb)

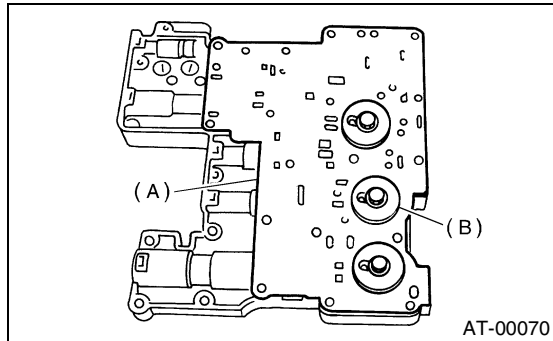

- (A) Upper separator plate
- (B) Side plate

6) Insert the six steel balls in their proper positions to middle valve body.

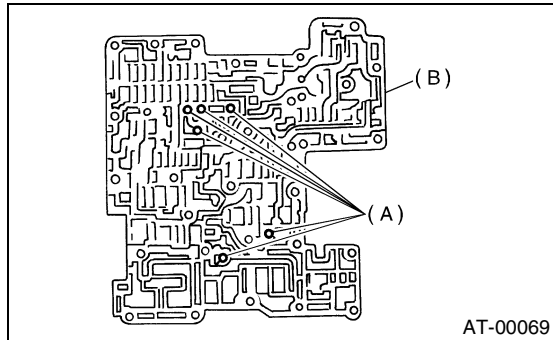

- (A) Steel ball
- (B) Middle valve body

7) Install the three filters to lower valve body.

NOTE:

Pay attention to the location of filters.

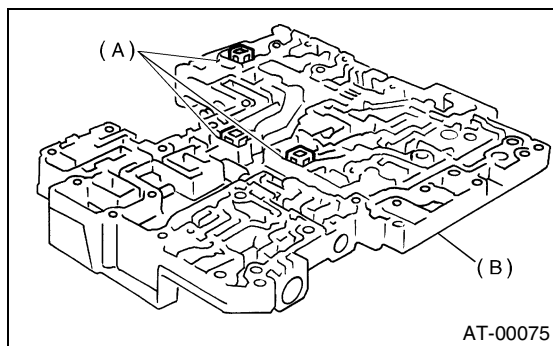

- (A) Strainer
- (B) Lower valve body

8) Install the lower separator plate to lower valve body.

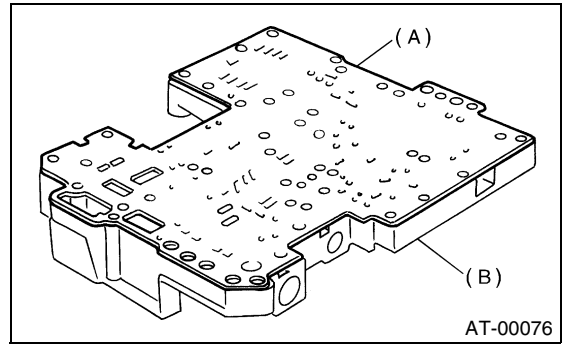

- (A) Lower separator plate
- (B) Lower valve body

9) Temporarily assemble the valve body.

NOTE:

Be careful not to drop the middle valve body and upper body interior steel ball, or the lower body filter.

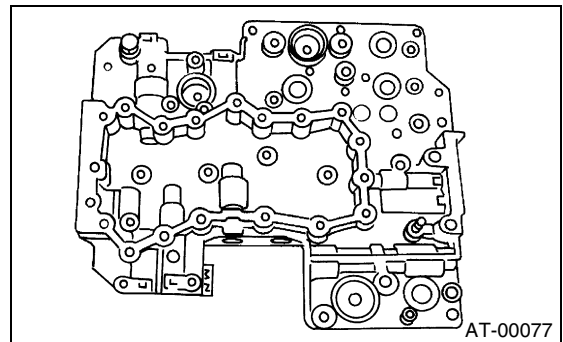

10) Tighten the bolts.

NOTE:

Install the bolts (D) from upper valve body side.

Tightening torque:

8 N·m (0.8 kgf·m, 5.8 ft·lb)

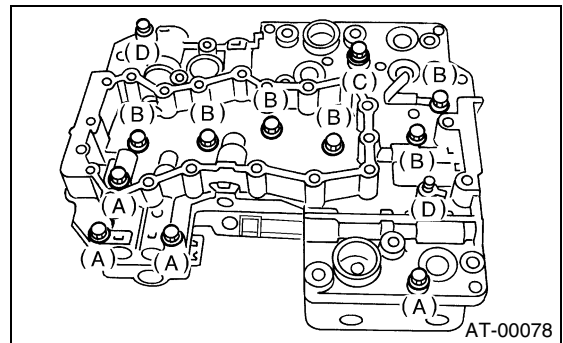

Bolt length mm (in)

- (A) 40 (1.57)
- (B) 62 (2.44)
- (C) 73 (2.87)
- (D) 79 (3.11)

11) Install the sensor, solenoids and duty solenoids to specified positions.

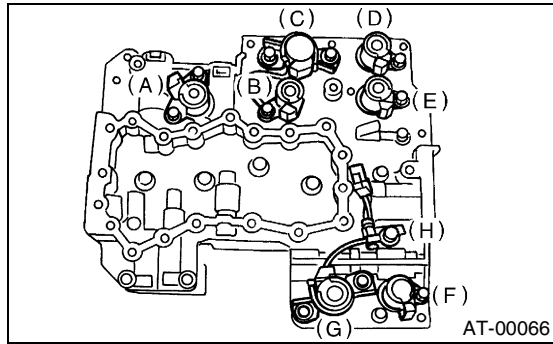

- (A) Lock-up duty solenoid (Blue)
- (B) Low clutch timing solenoid (Gray)
- (C) Line pressure duty solenoid (Red)
- (D) Shift solenoid 1 (Yellow)
- (E) Shift solenoid 2 (Green)
- (F) 2-4 brake timing solenoid (Black)
- (G) 2-4 brake duty solenoid (Red)
- (H) ATF temperature sensor

12) Tighten the bolts and nuts.

Tightening torque:

8 N·m (0.8 kgf-m, 5.8 ft-lb)

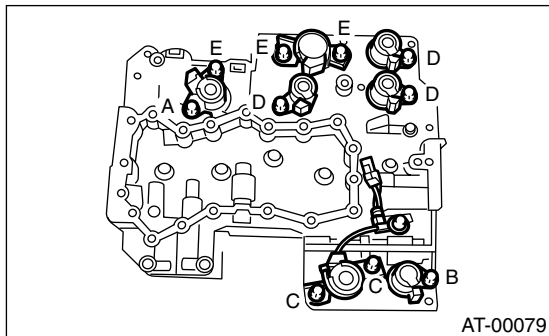

Bolt length mm (in)

- (A) 12 (0.47)
- (B) 40 (1.57)
- (C) 45 (1.77)
- (D) 62 (2.44)
- (E) 73 (2.87)

13) Install the oil strainer to lower valve body.

Tightening torque:

8 N·m (0.8 kgf-m, 5.8 ft-lb)

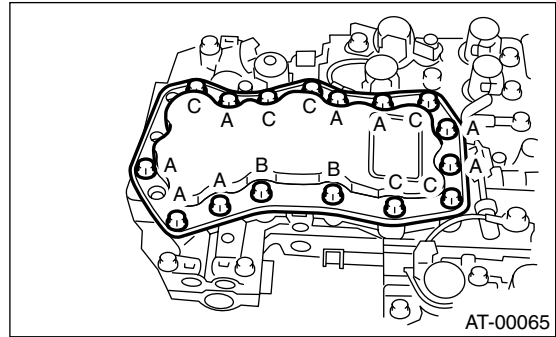

Bolt length mm (in)

- (A) 12 (0.47)
- (B) 62 (2.44)
- (C) 81 (3.19)

E: INSPECTION

Make sure that each component is free of harmful gouges, cuts, or dust.