

MANUAL TRANSMISSION AND DIFFERENTIAL

MT

	Page
1. General Description	2
2. Transmission Gear Oil	31
3. Manual Transmission Assembly	32
4. Transmission Mounting System	39
5. Oil Seal.....	41
6. Differential Side Retainer Oil Seal.....	42
7. Switches and Harness	43
8. Vehicle Speed Sensor.....	46
9. Preparation for Overhaul.....	47
10. Oil Pump	48
11. Transfer Case and Extension Case Assembly.....	50
12. Transfer Drive Gear	54
13. Transfer Driven Gear	56
14. Center Differential	58
15. Reverse Check Sleeve.....	59
16. Transmission Case	63
17. Main Shaft Assembly (Single-Range)	69
18. Main Shaft Assembly (Dual-Range).....	77
19. Input Shaft Assembly	83
20. Drive Pinion Shaft Assembly.....	87
21. Front Differential Assembly	95
22. Speedometer Gear.....	102
23. Reverse Idler Gear.....	103
24. Shifter Fork and Rod.....	105
25. Counter Gear	109
26. General Diagnostic.....	111

GENERAL DESCRIPTION

MANUAL TRANSMISSION AND DIFFERENTIAL

1. General Description

A: SPECIFICATIONS

1. MANUAL TRANSMISSION AND DIFFERENTIAL

Model		2.0L Non-turbo	2.5L	2.0L Turbo			
				Except Europe	Europe		
Type		5×2-forward speeds with synchromesh and 2-reverse		5-forward speeds with synchromesh and 1-reverse			
Transmission gear ratio		1st		3.454			
		2nd		2.062			
		3rd		1.448			
		4th		1.088			
		5th		0.825	0.780	0.738	
		Reverse		3.333			
Auxiliary transmission gear ratio		High		1.000			
		Low		1.447	1.196	—	
Front reduction gear	Final	Type of gear		Hypoid			
		Gear ratio		4.111	4.444		
Rear reduction gear	Transfer	Type of gear		Helical			
		Gear ratio		1.000	1.000	1.081	
	Final	Type of gear		Hypoid			
		Gear ratio		4.111	4.444	4.111	
Front differential	Type and number of gear		Straight bevel gear (Bevel pinion: 2, Bevel gear: 2)				
Center differential	Type and number of gear		Straight bevel gear (Bevel pinion: 2, Bevel gear: 2 and viscous coupling)				
Transmission gear oil		GL-5					
Transmission oil capacity		4.0 ℓ (4.2 US qt, 3.5 Imp qt)		3.5 ℓ (3.7 US qt, 3.1 Imp qt)	3.9 ℓ (4.1 US qt, 3.4 Imp qt)		

2. TRANSMISSION GEAR OIL

Recommended oil

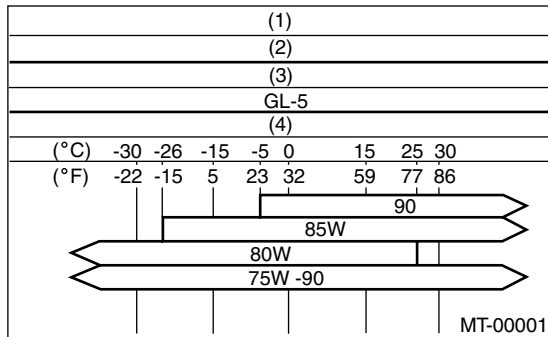

- (1) Item
- (2) Transmission gear oil
- (3) API classification
- (4) SAE viscosity No. and applicable temperature

GENERAL DESCRIPTION

MANUAL TRANSMISSION AND DIFFERENTIAL

3. TRANSMISSION CASE ASSEMBLY

Drive pinion shim adjustment

Hypoid gear backlash

0.13 — 0.18 mm (0.0051 — 0.0071 in)

Drive pinion shim			
Part No.	Thickness mm (in)	Part No.	Thickness mm (in)
32295AA031	0.150 (0.0059)	32295AA071	0.250 (0.0098)
32295AA041	0.175 (0.0069)	32295AA081	0.275 (0.0108)
32295AA051	0.200 (0.0079)	32295AA091	0.300 (0.0118)
32295AA061	0.225 (0.0089)	32295AA101	0.500 (0.0197)

Selection of main shaft rear plate

Main shaft rear plate		
Dimension "A" mm (in)	Part No.	Mark
4.00 — 4.13 (0.1575 — 0.1626)	32294AA041	1
3.87 — 3.99 (0.1524 — 0.1571)	32294AA051	2

Snap ring to counter washer clearance

0.05 — 0.35 mm (0.0020 — 0.0138 in)

Snap ring (Outer-19)	
Part No.	Thickness mm (in)
031319000	1.50 (0.0591)
805019010	1.72 (0.0677)

Input shaft holder adjustment

Dimension "D" mm (in)	Number of shim
52.50 — 53.11 (2.0669 — 2.0909)	—
52.00 — 52.49 (2.0472 — 2.0665)	1
51.26 — 51.99 (2.0181 — 2.0468)	2

4. DRIVE PINION ASSEMBLY

Preload adjustment of thrust bearing

Starting torque

0.3 — 0.8 N·m (0.03 — 0.08 kgf-m, 0.2 — 0.6 ft-lb)

Adjusting washer No. 1	
Part No.	Thickness mm (in)
803025051	3.925 (0.1545)
803025052	3.950 (0.1555)
803025053	3.975 (0.1565)
803025054	4.000 (0.1575)
803025055	4.025 (0.1585)
803025056	4.050 (0.1594)
803025057	4.075 (0.1604)

Adjusting washer No. 2	
Part No.	Thickness mm (in)
803025059	3.850 (0.1516)
803025054	4.000 (0.1575)
803025058	4.150 (0.1634)

5. INPUT SHAFT ASSEMBLY

Snap ring (Outer-28) to ball bearing clearance

0 — 0.12 mm (0 — 0.0047 in)

Snap ring (Outer-28)	
Part No.	Thickness mm (in)
805028050	2.48 (0.0976)
805028060	2.56 (0.1008)
805028070	2.64 (0.1039)

Snap ring (Inner-68) to bearing clearance

0 — 0.12 mm (0 — 0.0047 in)

Snap ring (Inner-68)	
Part No.	Thickness mm (in)
805168020	1.84 (0.0724)
805168030	1.92 (0.0756)
805168040	2.00 (0.0787)

6. MAIN SHAFT

Snap ring (Outer-25) to synchronizer hub clearance

0.060 — 0.100 mm (0.0024 — 0.0039 in)

Snap ring (Outer-25)			
Part No.	Thickness mm (in)	Part No.	Thickness mm (in)
805025051	2.42 (0.0953)	805025055	2.62 (0.1031)
805025052	2.47 (0.0972)	805025056	2.67 (0.1051)
805025053	2.52 (0.0992)	805025057	2.72 (0.1071)
805025054	2.57 (0.1012)	805025058	2.37 (0.0933)

GENERAL DESCRIPTION

MANUAL TRANSMISSION AND DIFFERENTIAL

7. REVERSE IDLER GEAR

Adjustment of reverse idler gear position
Reverse idler gear to transmission case (LH) wall clearance

6.0 — 7.5 mm (0.236 — 0.295 in)

Reverse shifter lever		
Part No.	Mark	Remarks
32820AA070	7	Further from case wall
32820AA080	8	Standard
32820AA090	9	Closer to the case wall

After installing a suitable reverse shifter lever, adjust the reverse idler gear to transmission case wall clearance to within 0 to 0.5 mm (0 to 0.020 in) using washers.

Washer (20.5 × 26 × t)			
Part No.	Thickness mm (in)	Part No.	Thickness mm (in)
803020151	0.4 (0.016)	803020154	1.9 (0.075)
803020152	1.1 (0.043)	803020155	2.3 (0.091)
803020153	1.5 (0.059)	—	—

8. SHIFTER FORK AND ROD

Select the suitable shifter forks so that both coupling sleeve and reverse driven gear are positioned in the center of their synchromesh mechanisms.

Rod end clearance

A: 1st-2nd — 3rd-4th

0.4 — 1.4 mm (0.016 — 0.055 in)

B: 3rd-4th — 5th

0.5 — 1.3 mm (0.020 — 0.051 in)

1st-2nd shifter fork		
Part No.	Mark	Remarks
32804AA060	1	Approach to 1st gear by 0.2 mm (0.008 in)
32804AA070	No mark	Standard
32804AA080	3	Approach to 2nd gear by 0.2 mm (0.008 in)

3rd-4th shifter fork		
Part No.	Mark	Remarks
32810AA061	1	Approach to 4th gear by 0.2 mm (0.008 in)
32810AA071	No mark	Standard
32810AA101	3	Approach to 3rd gear by 0.2 mm (0.008 in)

5th shifter fork (Non-turbo)		
Part No.	Mark	Remarks
32812AA201	7	Approach to 5th gear by 0.2 mm (0.008 in)
32812AA211	No mark	Standard
32812AA221	9	Become distant from 5th gear by 0.2 mm (0.008 in)

5th shifter fork (Turbo)		
Part No.	Mark	Remarks
32812AA231	7	Approach to 5th gear by 0.2 mm (0.008 in)
32812AA241	No mark	Standard
32812AA251	9	Become distant from 5th gear by 0.2 mm (0.008 in)

9. TRANSFER CASE OR REAR CASE

Neutral position adjustment

Adjustment shim	
Part No.	Thickness mm (in)
32190AA000	0.15 (0.0059)
32190AA010	0.30 (0.0118)

Reverse accent shaft		
Part No.	Mark	Remarks
32188AA090	X	Neutral position is closer to 1st.
32188AA100	Y	Standard
32188AA110	Z	Neutral position is closer to reverse gear.

Reverse check plate adjustment

Reverse check plate			
Part No.	Mark	Angle θ	Remarks
32189AA000	0	28°	Arm stops closer to 5th gear.
32189AA010	1	31°	Arm stops closer to 5th gear.
33189AA020	2	34°	Arm stops in the center.
32189AA030	3	37°	Arm stops closer to reverse gear.
32189AA040	4	40°	Arm stops closer to reverse gear.

GENERAL DESCRIPTION

MANUAL TRANSMISSION AND DIFFERENTIAL

10. EXTENSION ASSEMBLY

Thrust washer (50 × 61 × t) to taper roller bearing table outer race side clearance

0.2 — 0.3 mm T (0.0008 — 0.012 in T)

NOTE:

Be sure to set within the standard clearance.

Thrust washer (50 × 61 × t)	
Part No.	Thickness mm (in)
803050060	0.50 (0.0197)
803050061	0.55 (0.0217)
803050062	0.60 (0.0236)
803050063	0.65 (0.0256)
803050064	0.70 (0.0276)
803050065	0.75 (0.0295)
803050066	0.80 (0.0315)
803050067	0.85 (0.0335)
803050068	0.90 (0.0354)
803050069	0.95 (0.0374)
803050070	1.00 (0.0394)
803050071	1.05 (0.0413)
803050072	1.10 (0.0433)
803050073	1.15 (0.0453)
803050074	1.20 (0.0472)
803050075	1.25 (0.0492)
803050076	1.30 (0.0512)
803050077	1.35 (0.0531)
803050078	1.40 (0.0551)
803050079	1.45 (0.0571)

Thrust washer to center differential side clearance

0.15 — 0.35 mm (0.0059 — 0.0138 in)

Thrust washer	
Part No.	Thickness mm (in)
803036050	0.9 (0.035)
803036054	1.0 (0.039)
803036051	1.1 (0.043)
803036055	1.2 (0.047)
803036052	1.3 (0.051)
803036056	1.4 (0.055)
803036053	1.5 (0.059)
803036057	1.6 (0.063)
803036058	1.7 (0.067)

11. FRONT DIFFERENTIAL

Bevel gear to pinion backlash

0.13 — 0.18 mm (0.0051 — 0.0071 in)

Washer (38.1 × 50 × t)			
Part No.	Thickness mm (in)	Part No.	Thickness mm (in)
803038021	0.925 — 0.950 (0.0364 — 0.0374)	803038023	1.025 — 1.050 (0.0404 — 0.0413)
803038022	0.975 — 1.000 (0.0384 — 0.0394)	—	—

12. TRANSFER DRIVE GEAR

Snap ring (Outer-30) to ball bearing clearance

0.01 — 0.15 mm (0.0004 — 0.0059 in)

Snap ring (Outer-30)	
Part No.	Thickness mm (in)
805030041	1.53 (0.0602)
805030042	1.65 (0.0650)
805030043	1.77 (0.0697)

GENERAL DESCRIPTION

MANUAL TRANSMISSION AND DIFFERENTIAL

B: COMPONENT

1. TRANSMISSION CASE

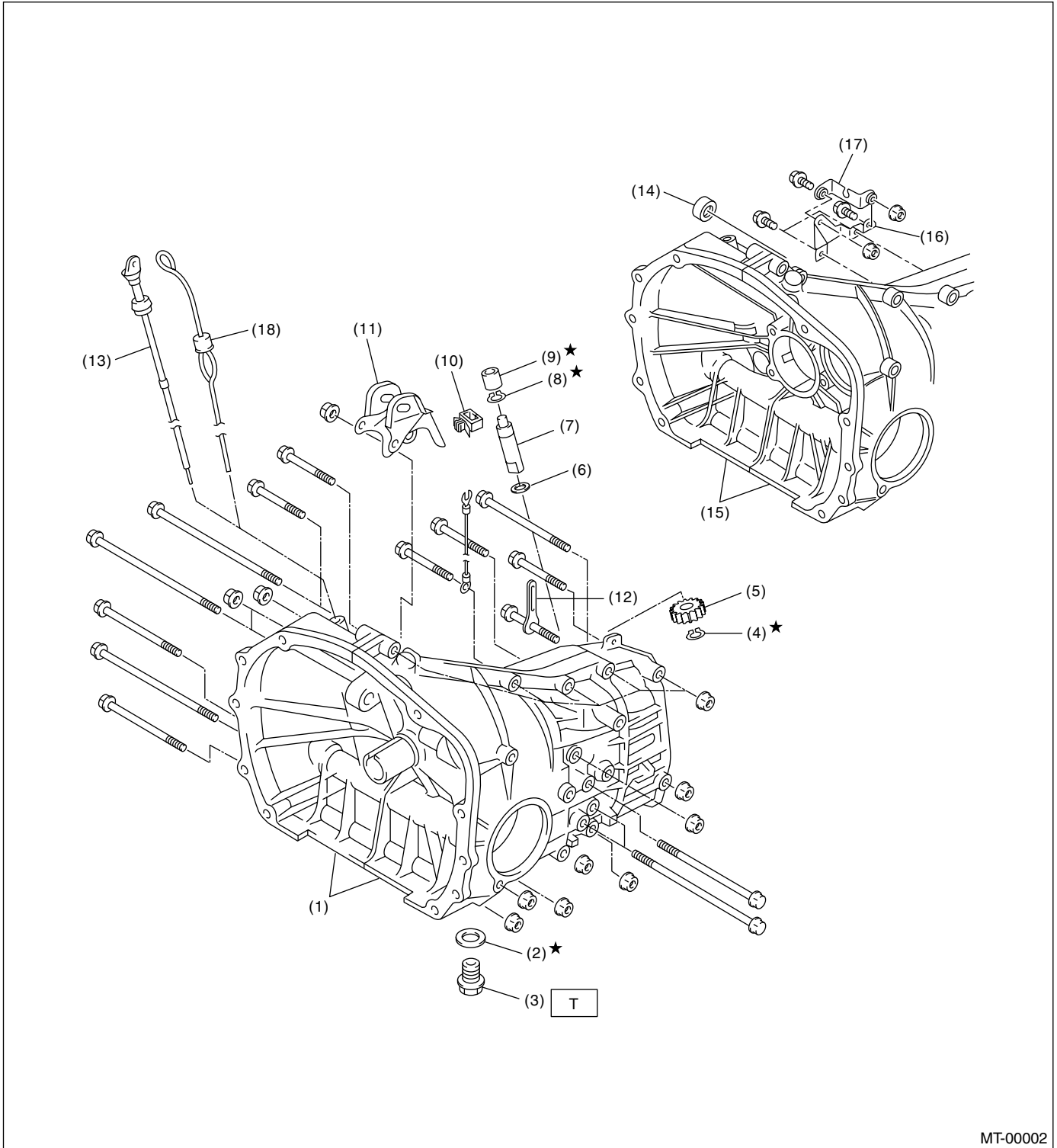

MT-00002

GENERAL DESCRIPTION

MANUAL TRANSMISSION AND DIFFERENTIAL

(1) Transmission case ASSY (Single-range)	(9) Oil seal	(16) High-low cable bracket A (Dual-range)
(2) Gasket	(10) Clamp	(17) High-low cable bracket B (Dual-range)
(3) Drain plug	(11) Pitching stopper bracket	(18) Oil level gauge (Turbo model)
(4) Snap ring (Outer)	(12) Clip	
(5) Speedometer driven gear	(13) Oil level gauge (Non-turbo model)	
(6) Washer	(14) Oil seal (Dual-range)	
(7) Speedometer shaft	(15) Transmission case ASSY (Dual-range)	
(8) Snap ring (Outer)		

Tightening torque: N·m (kgf·m, ft·lb)
T: 44 (4.5, 32.5)

• Transmission case tightening torque

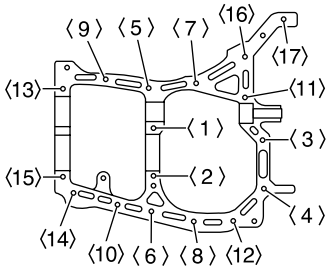
 <p style="text-align: right;">MT-00003</p>	Bolt No.	Bolt size	Tightening torque: N·m (kgf·m, ft·lb)
	<5> to <15>	8 mm	25 (2.5, 18.1)
	<1> to <4> <16>, <17>	10 mm	39 (4.0, 28.9)

GENERAL DESCRIPTION

MANUAL TRANSMISSION AND DIFFERENTIAL

2. DRIVE PINION ASSEMBLY

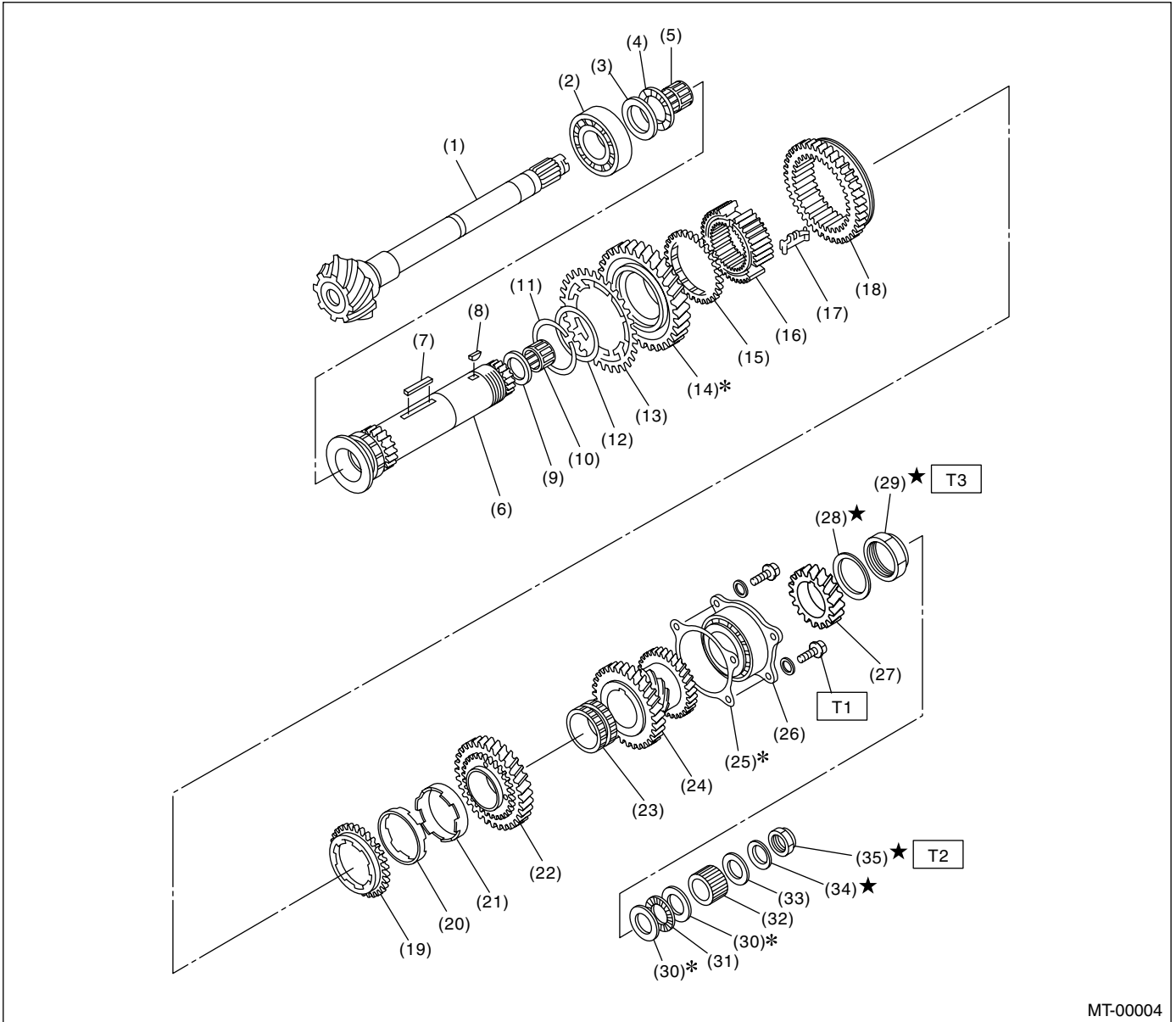

MT-00004

(1) Drive pinion shaft	(14) 1st driven gear	(28) Lock washer
(2) Roller bearing	(15) Baulk ring	(29) Lock nut
(3) Washer	(16) 1st-2nd synchronizer hub	(30) Washer
(4) Thrust bearing	(17) Insert key	(31) Thrust bearing
(5) Needle bearing	(18) Reverse driven gear	(32) Differential bevel gear sleeve
(6) Driven shaft	(19) Outer baulk ring	(33) Washer
(7) Key	(20) Synchro cone	(34) Lock washer
(8) Woodruff key	(21) Inner baulk ring	(35) Lock nut
(9) Drive pinion collar	(22) 2nd driven gear	
(10) Needle bearing	(23) 2nd driven gear bush	
(11) Snap ring (Outer) (Non-turbo model)	(24) 3rd-4th driven gear	
(12) Washer (Non-turbo model)	(25) Driven pinion shim	
(13) Sub gear (Non-turbo model)	(26) Roller bearing	
	(27) 5th driven gear	

Tightening torque: N·m (kgf·m, ft·lb)

T1: 30 (2.9, 21.0)

T2: 120 (12.2, 88.2)

T3: 260 (26.5, 192)

GENERAL DESCRIPTION

MANUAL TRANSMISSION AND DIFFERENTIAL

3. MAIN SHAFT ASSEMBLY (SINGLE RANGE)

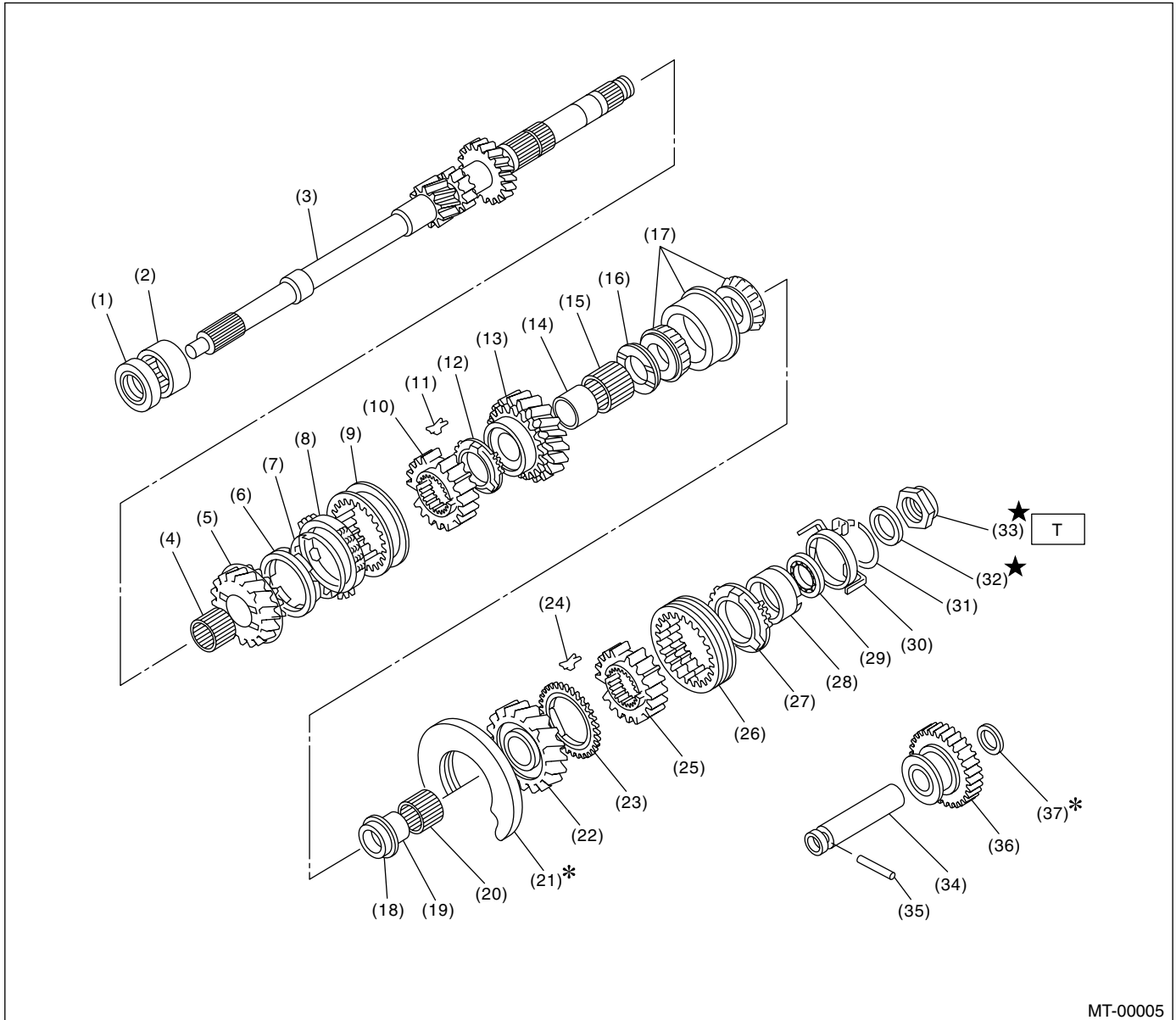

MT-00005

- | | | |
|----------------------------------|----------------------------------|-------------------------------|
| (1) Oil seal | (15) Needle bearing | (29) Ball bearing |
| (2) Needle bearing | (16) 4th gear thrust washer | (30) Synchro cone stopper |
| (3) Transmission main shaft | (17) Double taper roller bearing | (31) Snap ring |
| (4) Needle bearing | (18) 5th gear thrust washer | (32) Lock washer |
| (5) 3rd drive gear | (19) 5th needle bearing race | (33) Lock nut |
| (6) Inner baulk ring | (20) Needle bearing | (34) Reverse idler gear shaft |
| (7) 3rd synchro cone | (21) Main shaft rear plate | (35) Straight pin |
| (8) Outer baulk ring | (22) 5th drive gear | (36) Reverse idler gear |
| (9) 3rd-4th coupling sleeve | (23) 5th baulk ring | (37) Washer |
| (10) 3rd-4th synchronizer hub | (24) 5th-Rev shifting insert key | |
| (11) 3rd-4th shifting insert key | (25) 5th-Rev synchronizer hub | |
| (12) 4th baulk ring | (26) 5th-Rev coupling sleeve | |
| (13) 4th drive gear | (27) Rev baulk ring | |
| (14) 4th needle bearing race | (28) Rev synchro cone | |

Tightening torque: N-m (kgf-m, ft-lb)

T: 120 (12.2, 88.2)

GENERAL DESCRIPTION

MANUAL TRANSMISSION AND DIFFERENTIAL

4. MAIN SHAFT ASSEMBLY (DUAL RANGE)

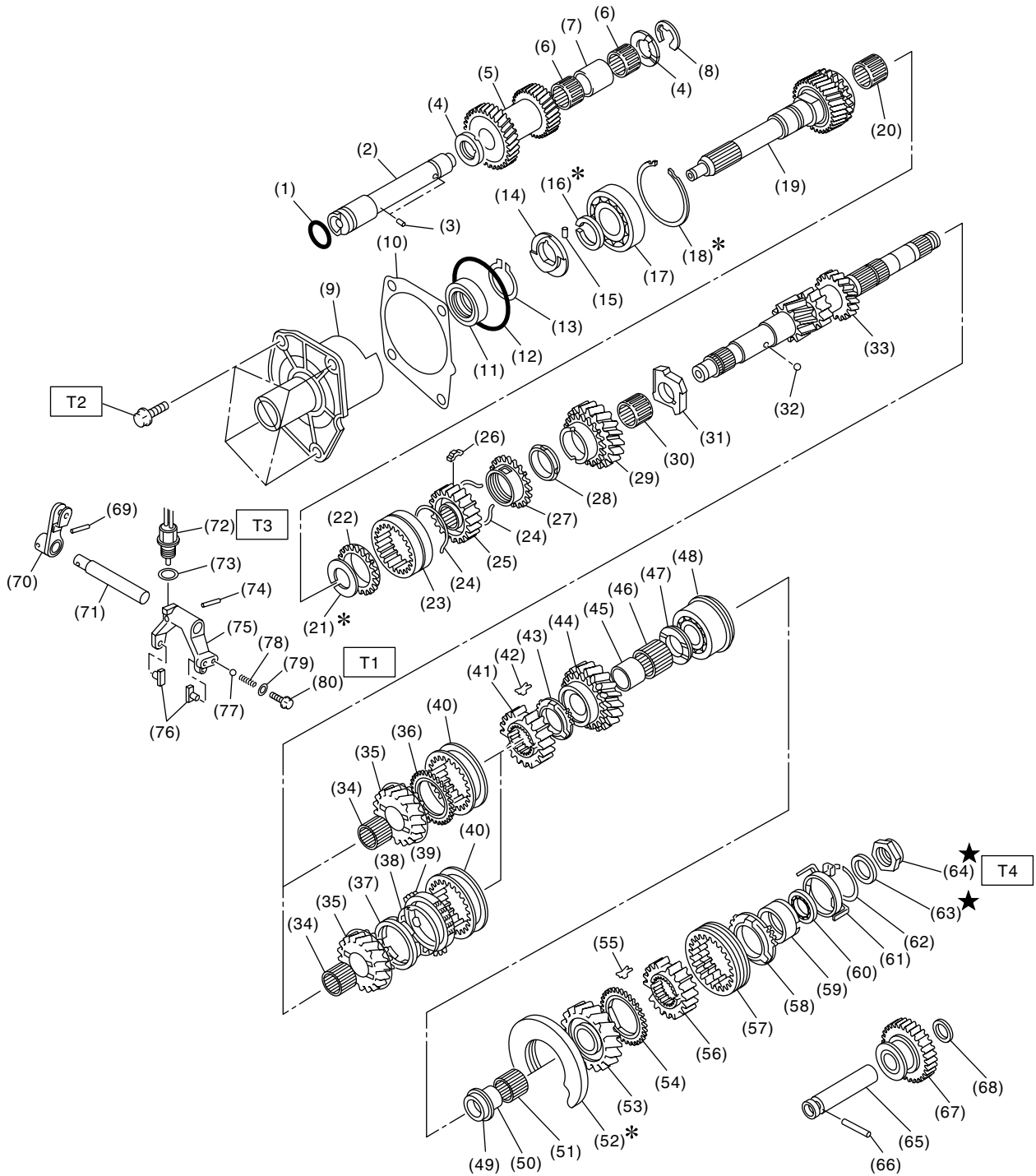

MT-00341

GENERAL DESCRIPTION

MANUAL TRANSMISSION AND DIFFERENTIAL

(1) O-ring	(30) Needle bearing	(59) Rev synchro cone
(2) High-low counter shaft	(31) Input low gear spacer	(60) Ball bearing
(3) Knock pin	(32) Ball	(61) Synchro cone stopper
(4) High-low counter washer	(33) Main shaft	(62) Snap ring
(5) Counter gear	(34) Needle bearing	(63) Lock washer
(6) Needle bearing	(35) 3rd drive gear	(64) Lock nut
(7) Counter gear collar	(36) 3rd baulk ring (2.0L model)	(65) Reverse idler gear shaft
(8) Snap ring (Outer-19)	(37) Inner baulk ring (2.5L model)	(66) Straight pin
(9) Input shaft holder	(38) 3rd synchro cone (2.5L model)	(67) Reverse idler gear
(10) Input shaft shim	(39) Outer baulk ring (2.5L model)	(68) Washer
(11) Oil seal	(40) 3rd-4th coupling sleeve	(69) Straight pin
(12) O-ring	(41) 3rd-4th synchronizer hub	(70) High-low shifter lever
(13) Snap ring (Outer-28)	(42) 3rd-4th shifting insert key	(71) High-low shifter shaft
(14) Oil squeeze	(43) 4th baulk ring	(72) Low switch
(15) Straight pin	(44) 4th drive gear	(73) Gasket
(16) Snap ring (Outer-28)	(45) 4th needle bearing race	(74) Straight pin
(17) Ball bearing	(46) Needle bearing	(75) High-low shifter fork
(18) Snap ring (Inner-68)	(47) 4th gear thrust washer	(76) High-low shifter piece
(19) Input shaft	(48) Ball bearing	(77) Ball
(20) Needle bearing	(49) 5th gear thrust washer	(78) Spring
(21) Snap ring (Outer-25)	(50) 5th needle bearing race	(79) Gasket
(22) High-low baulk ring	(51) Needle bearing	(80) Plug
(23) High-low coupling sleeve	(52) Main shaft rear plate	
(24) High-low synchronizer spring	(53) 5th drive gear	
(25) High-low synchronizer hub	(54) 5th baulk ring	
(26) Shifting insert key	(55) 5th-Rev shifting insert key	
(27) High-low baulk ring	(56) 5th-Rev synchronizer hub	
(28) Friction damper	(57) 5th-Rev coupling sleeve	
(29) Input low gear	(58) Rev baulk ring	

Tightening torque: N-m (kgf-m, ft-lb)**T1: 9.75 (0.99, 7.2)****T2: 20 (2.0, 14.5)****T3: 25 (2.5, 18.1)****T4: 120 (12.2, 88.2)**

GENERAL DESCRIPTION

MANUAL TRANSMISSION AND DIFFERENTIAL

5. SHIFTER FORK AND SHIFTER ROD

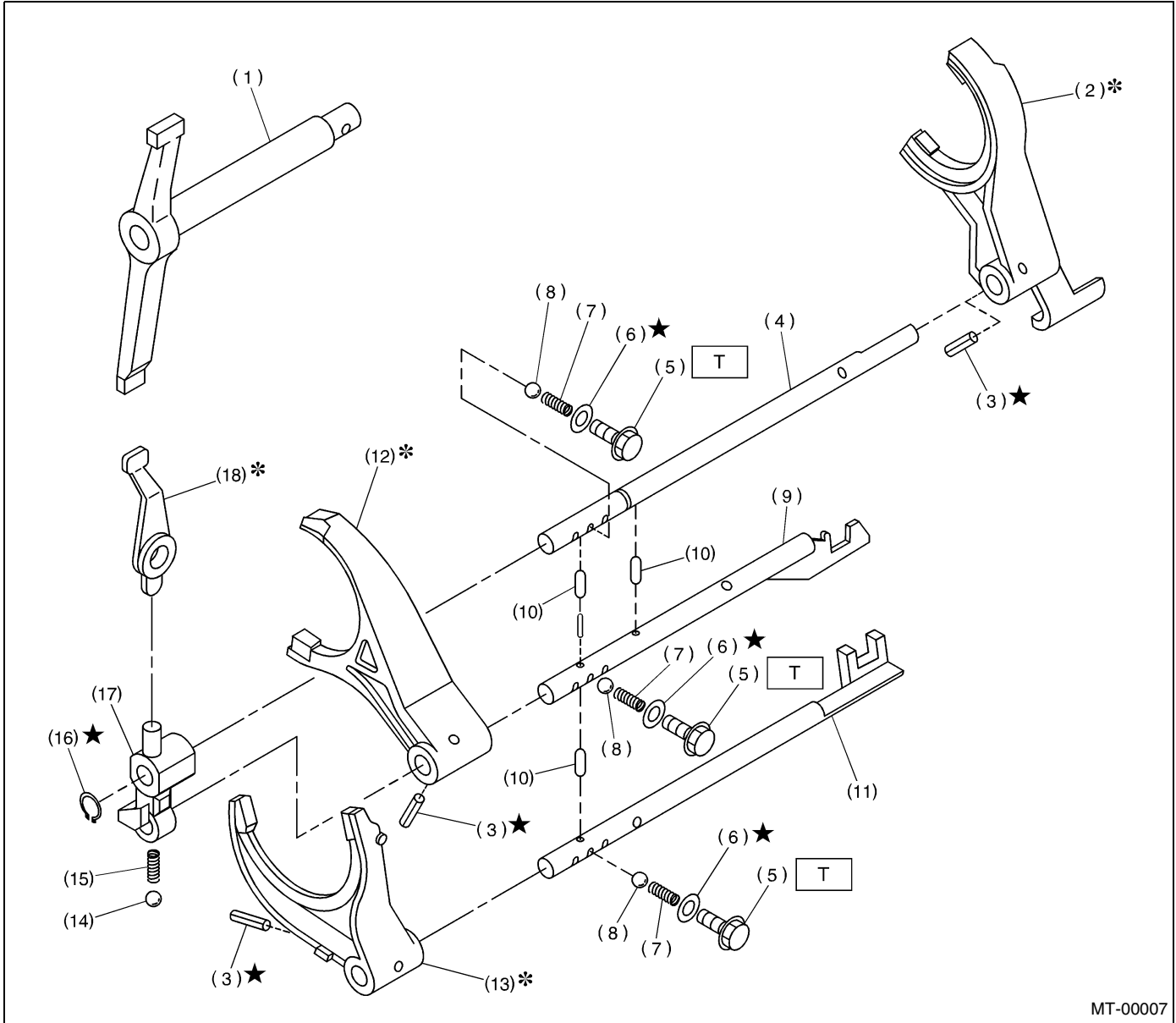

MT-00007

- | | | |
|--------------------------|---------------------------|----------------------------|
| (1) Shifter arm | (8) Ball | (15) Spring |
| (2) 5th shifter fork | (9) 3rd-4th fork rod | (16) Snap ring (Outer) |
| (3) Straight pin | (10) Interlock plunger | (17) Reverse fork rod arm |
| (4) Reverse fork rod | (11) 1st-2nd fork rod | (18) Reverse shifter lever |
| (5) Checking ball plug | (12) 3rd-4th shifter fork | |
| (6) Gasket | (13) 1st-2nd shifter fork | |
| (7) Checking ball spring | (14) Ball | |

Tightening torque: N-m (kgf-m, ft-lb)
T: 20 (2.0, 14.5)

GENERAL DESCRIPTION

MANUAL TRANSMISSION AND DIFFERENTIAL

6. TRANSFER CASE AND EXTENSION (WITHOUT OIL PUMP)

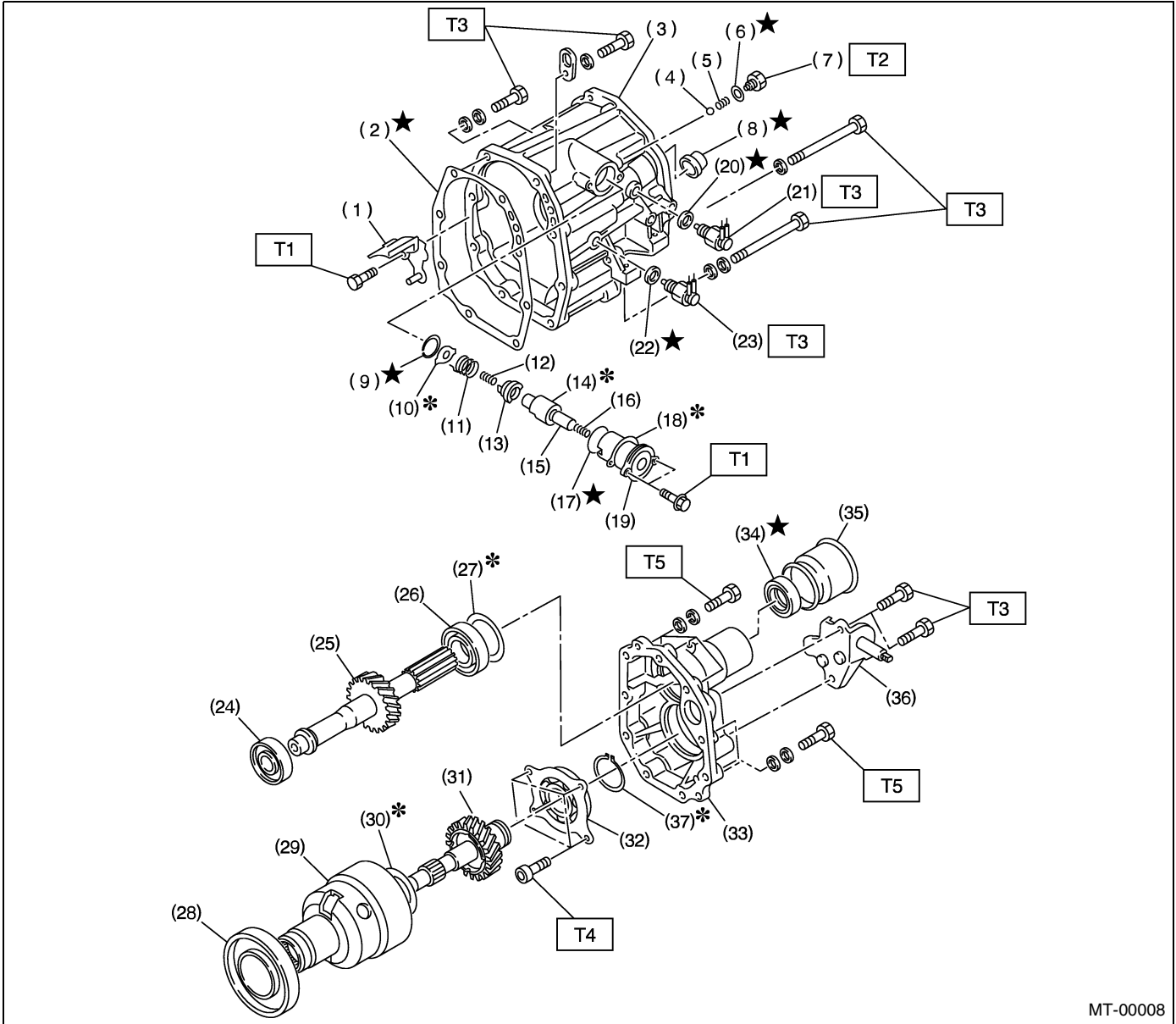

MT-00008

- | | | |
|----------------------------|----------------------------|--------------------------|
| (1) Oil guide | (16) Return spring | (31) Transfer drive gear |
| (2) Gasket | (17) O-ring | (32) Ball bearing |
| (3) Transfer case | (18) Adjusting select shim | (33) Extension case |
| (4) Ball | (19) Reverse check sleeve | (34) Oil seal |
| (5) Reverse accent spring | (20) Gasket | (35) Dust cover |
| (6) Gasket | (21) Neutral switch | (36) Shift bracket |
| (7) Plug | (22) Gasket | (37) Snap ring |
| (8) Oil seal | (23) Back-up light switch | |
| (9) Snap ring (Inner) | (24) Roller bearing | |
| (10) Reverse check plate | (25) Transfer driven gear | |
| (11) Reverse check spring | (26) Roller bearing | |
| (12) Reverse return spring | (27) Adjusting washer | |
| (13) Reverse check cam | (28) Ball bearing | |
| (14) Reverse accent shaft | (29) Center differential | |
| (15) Return spring cap | (30) Adjusting washer | |

Tightening torque: N·m (kgf·m, ft·lb)

T1: 6.4 (0.65, 4.7)

T2: 9.75 (1.0, 7.2)

T3: 24.5 (2.5, 18.1)

T4: 26 (2.7, 20)

T5: 40 (4.1, 30)

GENERAL DESCRIPTION

MANUAL TRANSMISSION AND DIFFERENTIAL

7. TRANSFER CASE AND EXTENSION (WITH OIL PUMP)

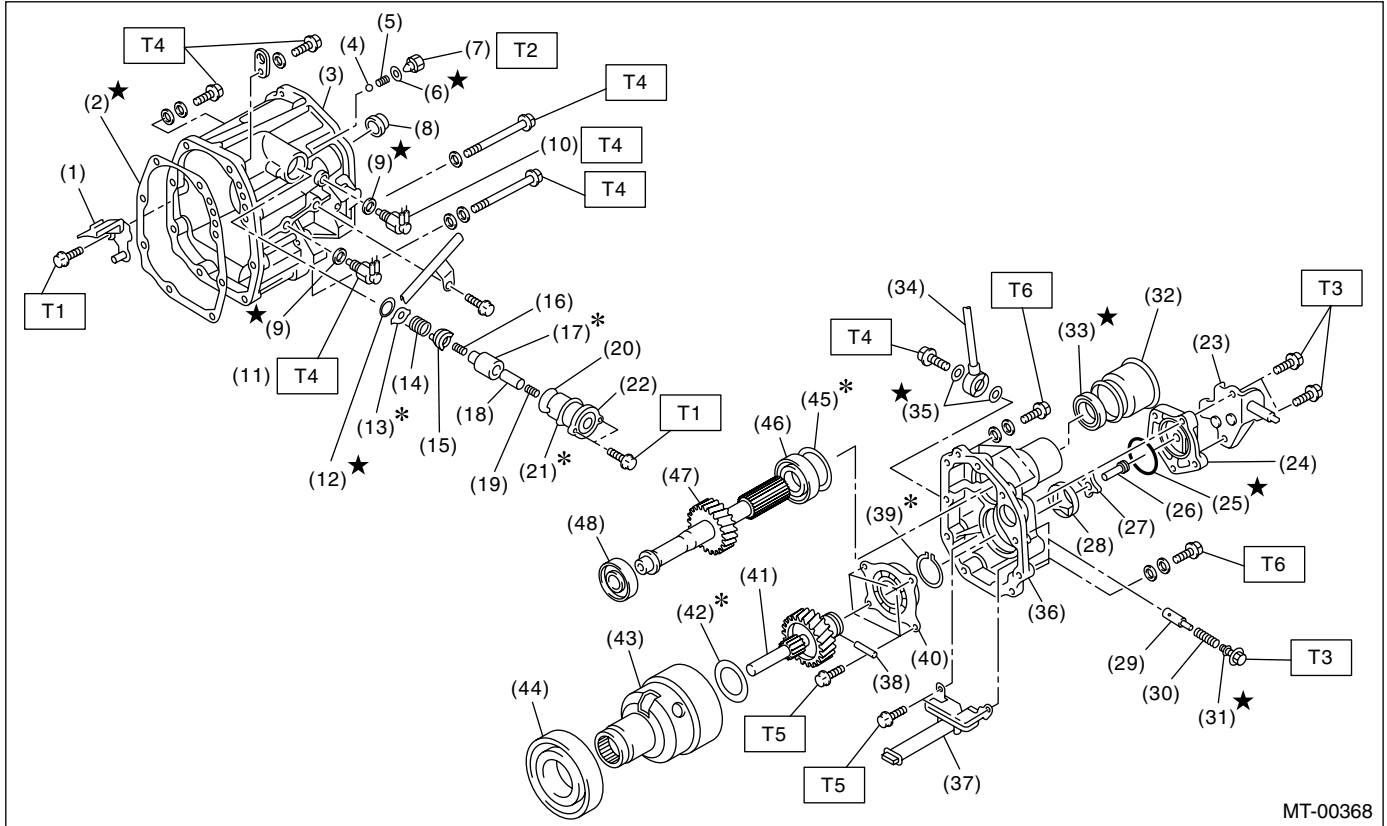

MT-00368

(1) Oil guide	(20) O-ring	(39) Snap ring
(2) Gasket	(21) Adjusting select shim	(40) Ball bearing
(3) Transfer case	(22) Reverse check sleeve	(41) Transfer drive gear
(4) Ball	(23) Shift bracket	(42) Washer
(5) Reverse accent spring	(24) Oil pump cover	(43) Center differential
(6) Gasket	(25) O-ring	(44) Ball bearing
(7) Plug	(26) Oil pump shaft	(45) Adjusting washer
(8) Oil seal	(27) Inner rotor	(46) Roller bearing
(9) Gasket	(28) Outer rotor	(47) Transfer driven gear
(10) Neutral switch	(29) Relief valve	(48) Roller bearing
(11) Back-up light switch	(30) Return spring	
(12) Snap ring (Inner)	(31) O-ring	
(13) Reverse check spring	(32) Dust cover	
(14) Reverse check spring	(33) Oil seal	
(15) Reverse check cam	(34) Outlet pipe	
(16) Return spring	(35) Gasket	
(17) Reverse accent shaft	(36) Extension case	
(18) Return spring cap	(37) Oil strainer	
(19) Return spring	(38) Straight pin	

Tightening torque: N-m (kgf-m, ft-lb)

T1: 6.4 (0.65, 4.7)

T2: 9.75 (1.0, 7.2)

T3: 12.75 (1.3, 9.4)

T4: 24.5 (2.5, 18.1)

T5: 26 (2.7, 20)

T6: 40 (4.1, 30)

GENERAL DESCRIPTION

MANUAL TRANSMISSION AND DIFFERENTIAL

8. FRONT DIFFERENTIAL

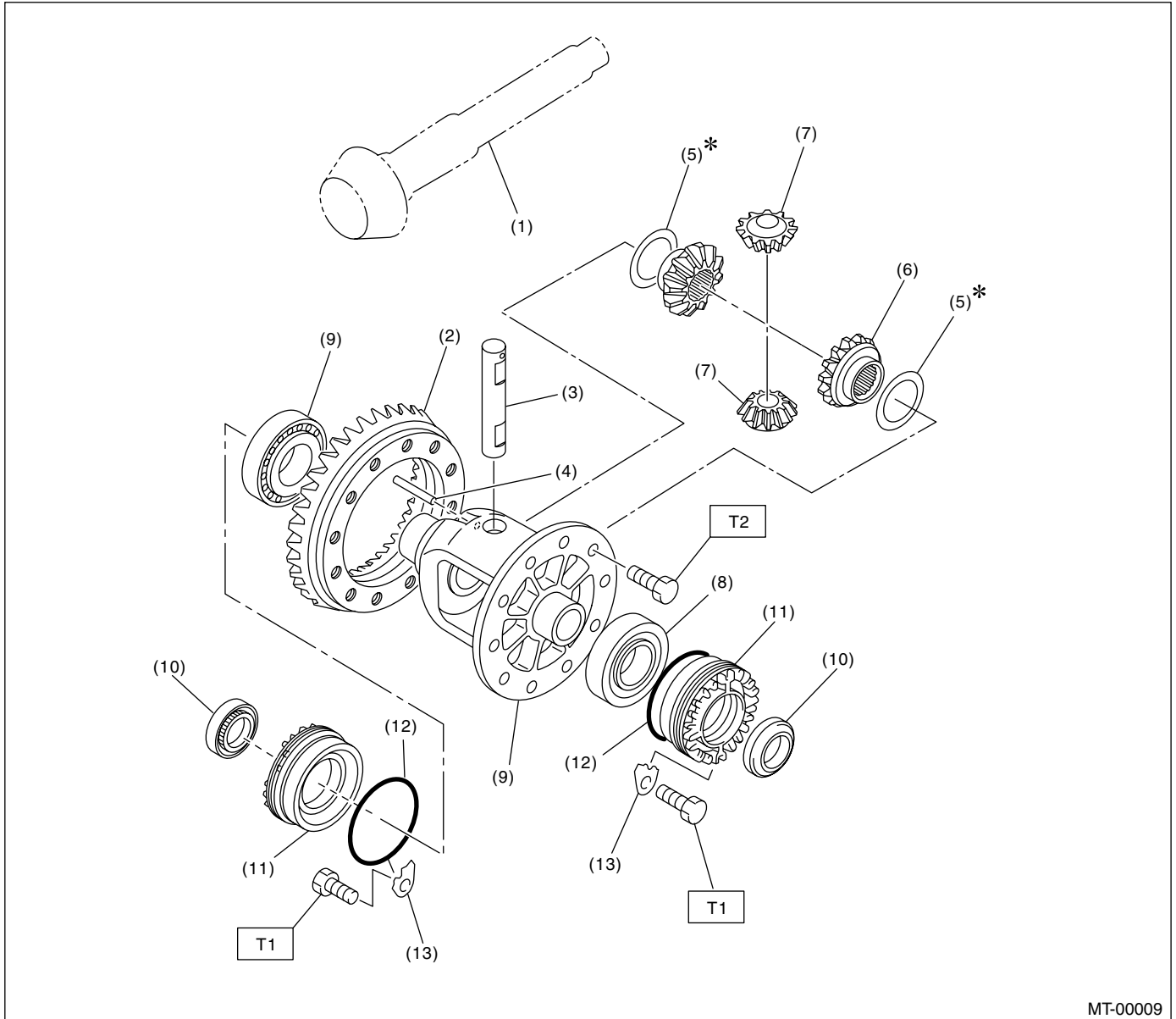

- | | | |
|-----------------------------|---------------------------------|--------------------------|
| (1) Drive pinion shaft | (7) Differential bevel pinion | (13) Retainer lock plate |
| (2) Hypoid driven gear | (8) Roller bearing | |
| (3) Pinion shaft | (9) Differential case | |
| (4) Straight pin | (10) Oil seal | |
| (5) Washer | (11) Differential side retainer | |
| (6) Differential bevel gear | (12) O-ring | |

Tightening torque: N·m (kgf·m, ft·lb)

T1: 25 (2.5, 18.1)

T2: 62 (6.3, 45.6)

GENERAL DESCRIPTION

MANUAL TRANSMISSION AND DIFFERENTIAL

9. TRANSMISSION MOUNTING

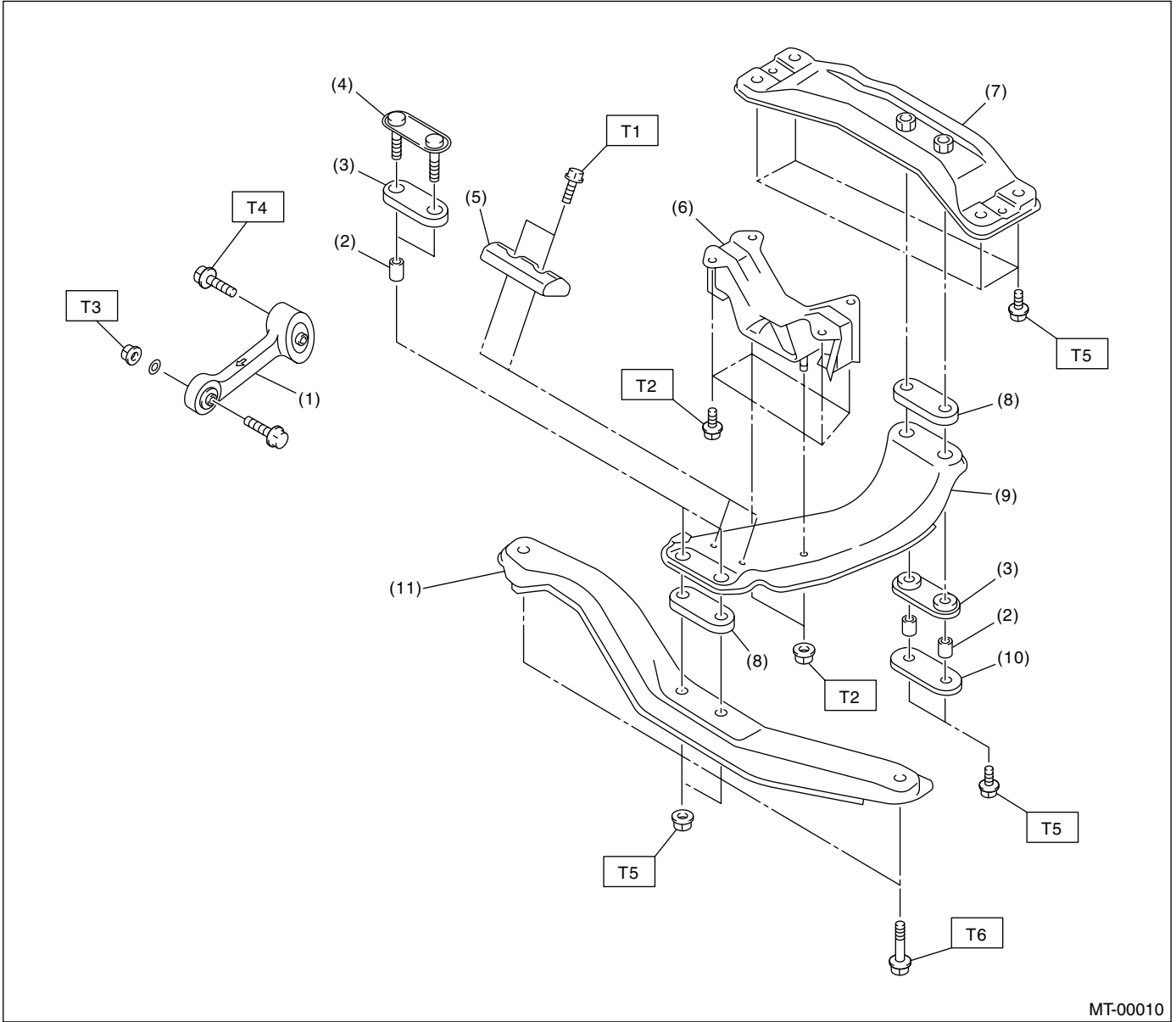

MT-00010

- | | |
|-------------------------|------------------------|
| (1) Pitching stopper | (8) Cushion D |
| (2) Spacer | (9) Center crossmember |
| (3) Cushion C | (10) Rear plate |
| (4) Front plate | (11) Front crossmember |
| (5) Dynamic damper | |
| (6) Rear cushion rubber | |
| (7) Rear crossmember | |

Tightening torque: N-m (kgf-m, ft-lb)

T1: 7.5 (0.76, 5.5)

T2: 35 (3.6, 26)

T3: 50 (5.1, 37)

T4: 58 (5.9, 43)

T5: 70 (7.1, 51)

T6: 140 (14.3, 103)

GENERAL DESCRIPTION

MANUAL TRANSMISSION AND DIFFERENTIAL

C: CAUTION

- Wear working clothing, including a cap, protective goggles, and protective shoes during operation.
- Remove contamination including dirt and corrosion before removal, installation, and disassembly.
- Keep the disassembled parts in order and protect them from dust or dirt.
- Before removal, installation or disassembly, be sure to clarify the failure. Avoid unnecessary removal, installation, disassembly and replacement.
- When disassembling the case and other light alloy parts, use a plastic hammer to force it apart. Do not pry it apart with a screwdriver or other tool.
- Be careful not to burn your hands, because each part on the vehicle is hot after running.
- Use SUBARU genuine gear oil, grease etc. or the equivalent. Do not mix gear oil, grease etc. with that of another grade or from other manufacturers.

- Be sure to tighten fasteners including bolts and nuts to the specified torque.
- Place shop jacks or safety stands at the specified points.
- Apply gear oil onto sliding or revolution surfaces before installation.
- Replace deformed or otherwise damaged snap rings with new ones.
- Before installing O-rings or oil seals, apply sufficient amount of gear oil to avoid damage and deformation.
- Be careful not to incorrectly install or fail to install O-rings, snap rings and other such parts.
- Before securing a part on a vise, place cushioning material such as wood blocks, aluminum plate, or shop cloth between the part and the vise.
- Avoid damaging the mating surface of the case.
- Before applying sealant, completely remove the old seal.

D: PREPARATION TOOL

1. SPECIAL TOOLS

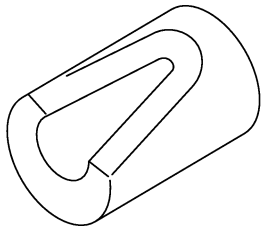
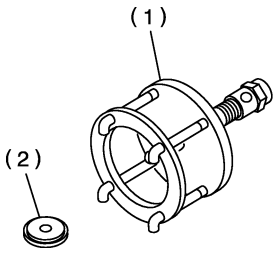
ILLUSTRATION	TOOL NUMBER	DESCRIPTION	REMARKS
 ST-399411700	399411700	ACCENT BALL INSTALLER	Used for installing reverse shifter rail arm.
 ST-899524100	899524100	PULLER ASSY	Used for removing and installing roller bearing (Differential). (1) Puller (2) Cap

GENERAL DESCRIPTION

MANUAL TRANSMISSION AND DIFFERENTIAL

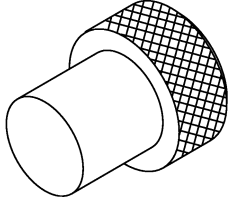
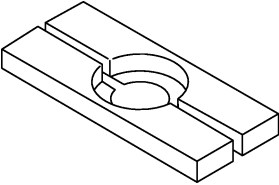
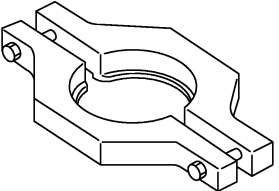
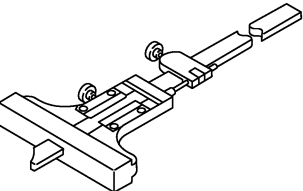
ILLUSTRATION	TOOL NUMBER	DESCRIPTION	REMARKS
 <p style="text-align: center;">ST-399780104</p>	399780104	WEIGHT	Used for measuring preload on roller bearing.
 <p style="text-align: center;">ST-498077000</p>	498077000	REMOVER	Used for removing roller bearing of drive pinion shaft.
 <p style="text-align: center;">ST-498077300</p>	498077300	CENTER DIFFERENTIAL BEARING REMOVER	Used for removing the center differential cover ball bearing.
 <p style="text-align: center;">ST-498147000</p>	498147000	DEPTH GAUGE	Used for adjusting main shaft axial end play.

GENERAL DESCRIPTION

MANUAL TRANSMISSION AND DIFFERENTIAL

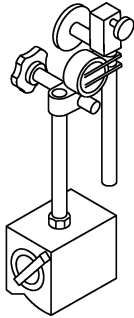
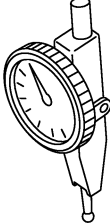
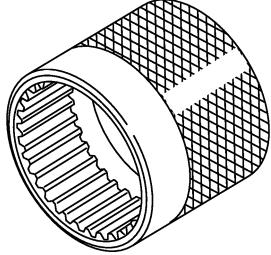
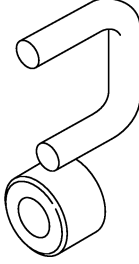
ILLUSTRATION	TOOL NUMBER	DESCRIPTION	REMARKS
 <p style="text-align: center;">ST-498247001</p>	498247001	MAGNET BASE	<ul style="list-style-type: none"> • Used for measuring backlash between side gear and pinion, and hypoid gear. • Used with DIAL GAUGE (498247100).
 <p style="text-align: center;">ST-498247100</p>	498247100	DIAL GAUGE	<ul style="list-style-type: none"> • Used for measuring backlash between side gear and pinion, and hypoid gear. • Used with MAGNET BASE (498247001).
 <p style="text-align: center;">ST-498247400</p>	498247400	STOPPER	Used for securing the drive pinion shaft assembly and driven gear assembly when removing the drive pinion shaft assembly lock nut.
 <p style="text-align: center;">ST-498787100</p>	498787100	MAIN SHAFT STOPPER	Used for removing and installing transmission main shaft lock nut.

GENERAL DESCRIPTION

MANUAL TRANSMISSION AND DIFFERENTIAL

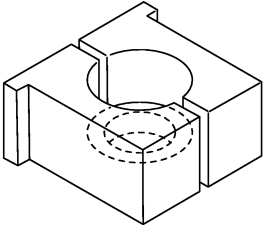
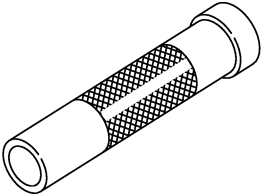
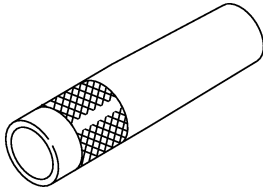
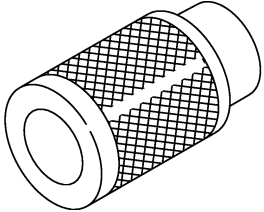
ILLUSTRATION	TOOL NUMBER	DESCRIPTION	REMARKS
 <p style="text-align: center;">ST-498937000</p>	498937000	TRANSMISSION HOLDER	Used for removing and installing transmission main shaft lock nut.
 <p style="text-align: center;">ST-499277100</p>	499277100	BUSH 1-2 INSTALLER	<ul style="list-style-type: none"> • Used for installing 1st driven gear thrust plate and 1st-2nd driven gear bush. • Used for installing roller bearing outer races to differential case.
 <p style="text-align: center;">ST-499277200</p>	499277200	INSTALLER	Used for press-fitting the 2nd driven gear, roller bearings, and 5th driven gear onto the driven shaft.
 <p style="text-align: center;">ST-499757002</p>	499757002	INSTALLER	<ul style="list-style-type: none"> • Used for installing snap ring (OUT 25), and ball bearing (25 x 26 x 17). • Used for installing bearing cone of transfer driven gear (extension core side).

GENERAL DESCRIPTION

MANUAL TRANSMISSION AND DIFFERENTIAL

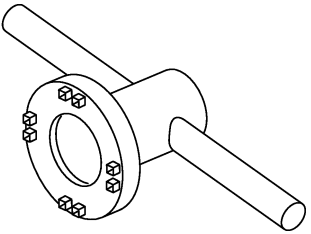
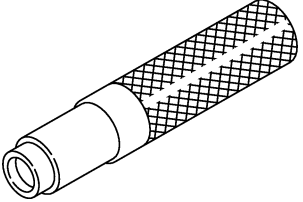
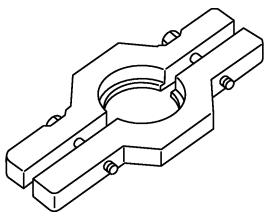
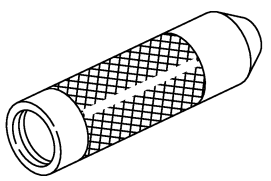
ILLUSTRATION	TOOL NUMBER	DESCRIPTION	REMARKS
 <p style="text-align: center;">ST-499787000</p>	499787000	WRENCH ASSY	Used for removing and installing differential side retainer.
 <p style="text-align: center;">ST-499827000</p>	499827000	PRESS	Used for installing speedometer oil seal when installing speedometer cable to transmission.
 <p style="text-align: center;">ST-499857000</p>	499857000	5TH DRIVEN GEAR REMOVER	Used for removing 5th driven gear.
 <p style="text-align: center;">ST-499877000</p>	499877000	RACE 4-5 INSTALLER	<ul style="list-style-type: none"> • Used for installing 4th needle bearing race and ball bearing onto transmission main shaft. • Used with REMOVER (899714110).

GENERAL DESCRIPTION

MANUAL TRANSMISSION AND DIFFERENTIAL

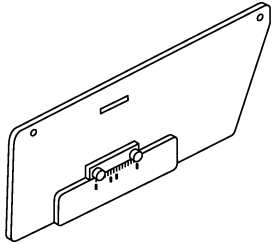
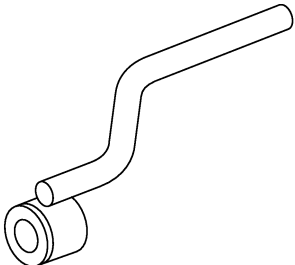
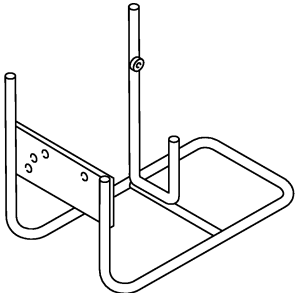
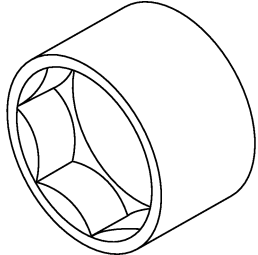
ILLUSTRATION	TOOL NUMBER	DESCRIPTION	REMARKS
 <p style="text-align: center;">ST-499917500</p>	499917500	DRIVE PINION GAUGE ASSY	Used for adjusting drive pinion shim.
 <p style="text-align: center;">ST-499927100</p>	499927100	HANDLE	Used for fitting transmission main shaft.
 <p style="text-align: center;">ST-499937100</p>	499937100	TRANSMISSION STAND SET	Stand used for transmission disassembly and assembly.
 <p style="text-align: center;">ST-499987003</p>	499987003	SOCKET WRENCH (35)	Used for removing and installing driven pinion lock nut and main shaft lock nut.

GENERAL DESCRIPTION

MANUAL TRANSMISSION AND DIFFERENTIAL

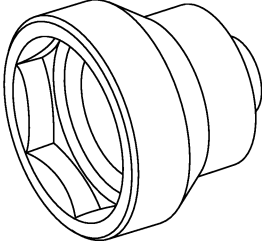
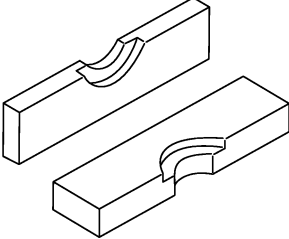
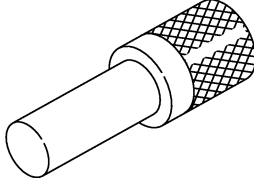
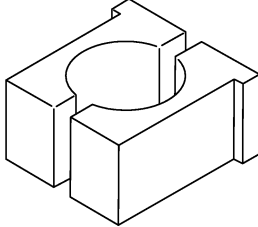
ILLUSTRATION	TOOL NUMBER	DESCRIPTION	REMARKS
 <p data-bbox="339 562 472 583">ST-499987300</p>	499987300	SOCKET WRENCH (50)	Used for removing and installing driven gear assembly lock nut.
 <p data-bbox="339 963 472 984">ST-899714110</p>	899714110	REMOVER	Used for fixing transmission main shaft, drive pinion, rear drive shaft.
 <p data-bbox="339 1367 472 1388">ST-899864100</p>	899864100	REMOVER	Used for removing parts on transmission main shaft and drive pinion.
 <p data-bbox="339 1770 472 1791">ST-899884100</p>	899884100	HOLDER	Used for tightening lock nut on sleeve.

GENERAL DESCRIPTION

MANUAL TRANSMISSION AND DIFFERENTIAL

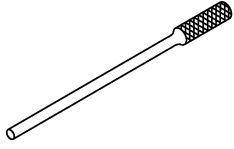
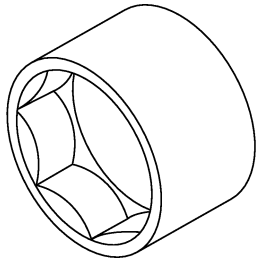
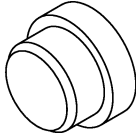
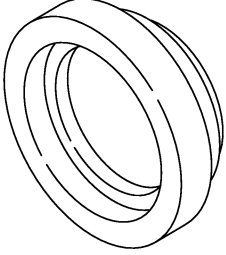
ILLUSTRATION	TOOL NUMBER	DESCRIPTION	REMARKS
 <p style="text-align: center;">ST-899904100</p>	899904100	REMOVER	Used for removing and installing straight pin.
 <p style="text-align: center;">ST-899988608</p>	899988608	SOCKET WRENCH (27)	Used for removing and installing drive pinion lock nut.
 <p style="text-align: center;">ST-398497701</p>	398497701	ADAPTER	<ul style="list-style-type: none"> • Used for installing roller bearing onto differential case. • Used with INSTALLER (499277100).
 <p style="text-align: center;">ST-499587000</p>	499587000	INSTALLER	Used for installing driven gears to driven shaft.

GENERAL DESCRIPTION

MANUAL TRANSMISSION AND DIFFERENTIAL

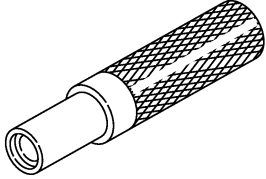
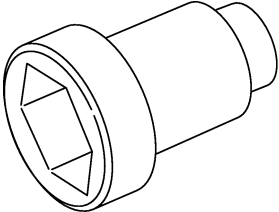
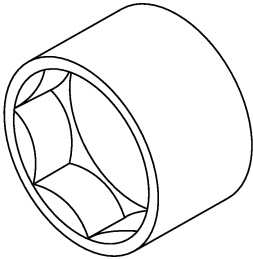
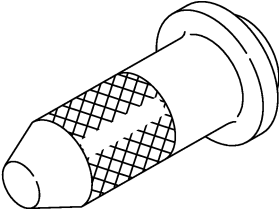
ILLUSTRATION	TOOL NUMBER	DESCRIPTION	REMARKS
 ST-899824100	899824100	PRESS	Used for installing speedometer shaft oil seal.
 ST-499987100	499987100	SOCKET WRENCH (35)	Used for removing and installing drive pinion lock nut.
 ST-899984103	899984103	SOCKET WRENCH (35)	Used for removing and installing drive pinion lock nut.
 ST-498057300	498057300	INSTALLER	Used for installing extension oil seal.

GENERAL DESCRIPTION

MANUAL TRANSMISSION AND DIFFERENTIAL

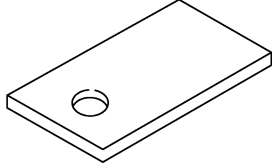
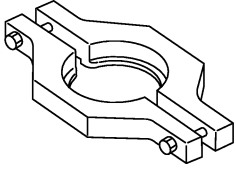
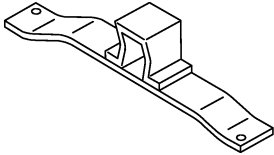
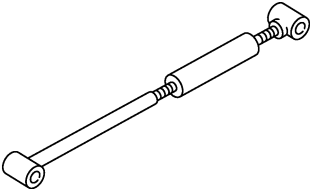
ILLUSTRATION	TOOL NUMBER	DESCRIPTION	REMARKS
 <p style="text-align: center;">ST-498255400</p>	498255400	PLATE	Used for measuring backlash.
 <p style="text-align: center;">ST-498077400</p>	498077400	SYNCHRONIZER CONE REMOVER	<ul style="list-style-type: none"> • Used for removing synchronizer cone of main shaft. • Used for removing 5th driven gear of drive pinion shaft.
 <p style="text-align: center;">ST41099AA010</p>	41099AA010	ENGINE SUPPORT BRACKET	Used for supporting engine.
 <p style="text-align: center;">ST41099AA020</p>	41099AA020	ENGINE SUPPORT	Used for supporting engine.

GENERAL DESCRIPTION

MANUAL TRANSMISSION AND DIFFERENTIAL

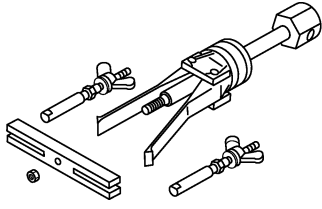
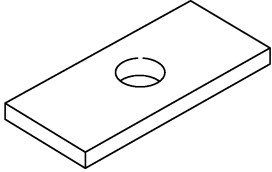
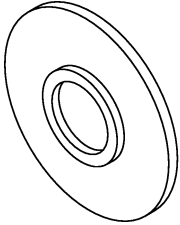
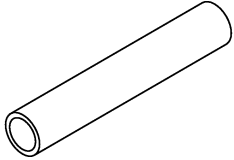
ILLUSTRATION	TOOL NUMBER	DESCRIPTION	REMARKS
 <p>ST-398527700</p>	398527700	PULLER ASSY	<ul style="list-style-type: none">• Used for removing extension case oil seal.• Used for removing front differential side retainer oil seal.
 <p>ST-398643600</p>	398643600	GAUGE	Used for measuring total end play, extension end play and drive pinion height.
 <p>ST-398177700</p>	398177700	INSTALLER	<ul style="list-style-type: none">• Used for installing bearing cone of transfer driven gear (transfer case side).• Used for installing ball bearing of transfer drive gear.
 <p>ST-398507703</p>	398507703	DUMMY COLLAR	<ul style="list-style-type: none">• Used for installing input shaft holder oil seal.• For dual-range model.

GENERAL DESCRIPTION

MANUAL TRANSMISSION AND DIFFERENTIAL

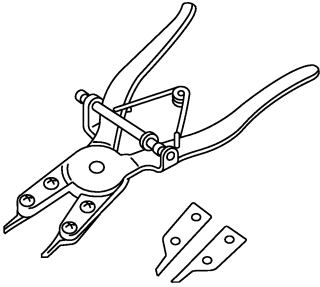
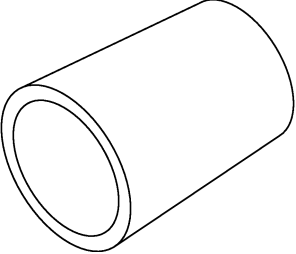
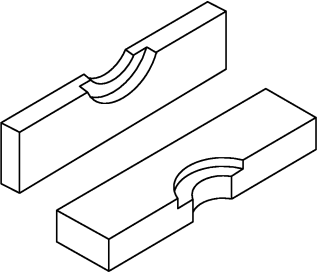
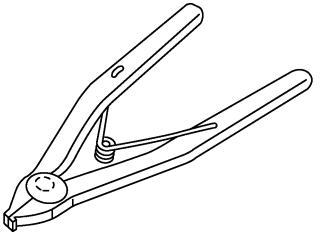
ILLUSTRATION	TOOL NUMBER	DESCRIPTION	REMARKS
 <p style="text-align: center;">ST-398663600</p>	398663600	PLIERS	<ul style="list-style-type: none"> • Used for removing and installing input shaft snap ring. • For dual-range model.
 <p style="text-align: center;">ST-499757001</p>	499757001	SNAP RING GUIDE	<ul style="list-style-type: none"> • Used for installing snap ring (OUT 25). • For dual-range model.
 <p style="text-align: center;">ST-899858600</p>	899858600	RETAINER	<ul style="list-style-type: none"> • Used for removing ball bearing. • For dual-range model.
 <p style="text-align: center;">ST-899474100</p>	899474100	EXPANDER	<ul style="list-style-type: none"> • Used for removing and installing snap ring. • For dual-range model.

GENERAL DESCRIPTION

MANUAL TRANSMISSION AND DIFFERENTIAL

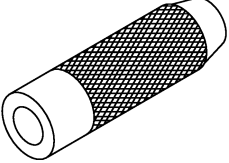
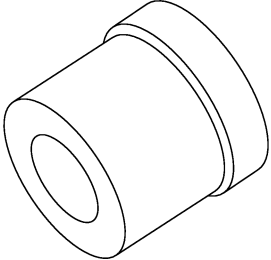
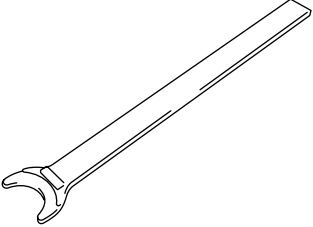
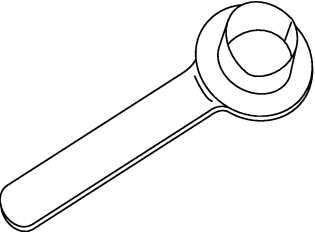
ILLUSTRATION	TOOL NUMBER	DESCRIPTION	REMARKS
 <p style="text-align: center;">ST-899580100</p>	<p style="text-align: center;">899580100</p>	<p style="text-align: center;">INSTALLER</p>	<ul style="list-style-type: none"> • Used when pressing ball bearings into input shaft. • For dual-range model.
 <p style="text-align: center;">ST-399513600</p>	<p style="text-align: center;">399513600</p>	<p style="text-align: center;">INSTALLER</p>	<ul style="list-style-type: none"> • Used when pressing ball bearings into input shaft. • For dual-range model.
 <p style="text-align: center;">ST28399SA000</p>	<p style="text-align: center;">28399SA000 <Newly adopted tool></p>	<p style="text-align: center;">FRONT DRIVE SHAFT REMOVER</p>	<p>Used for removing front drive shaft. (Commonly used for MT vehicles and AT vehicles)</p>
 <p style="text-align: center;">ST28399SA010</p>	<p style="text-align: center;">28399SA010 <Newly adopted tool></p>	<p style="text-align: center;">FRONT DRIVE SHAFT OIL SEAL PROTECTOR</p>	<p>Used for protecting oil seal when installing front drive shaft.</p>

GENERAL DESCRIPTION

MANUAL TRANSMISSION AND DIFFERENTIAL

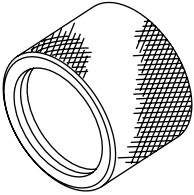
ILLUSTRATION	TOOL NUMBER	DESCRIPTION	REMARKS
 <p style="text-align: center;">ST18675AA000</p>	<p style="text-align: center;">18675AA000 <Newly adopted tool></p>	<p style="text-align: center;">DIFFERENTIAL SIDE OIL SEAL INSTALLER</p>	<p>Used for installing differential side retainer oil seal.</p>

2. GENERAL PURPOSE TOOLS

TOOL NAME	REMARKS
Circuit Tester	Used for measuring resistance, voltage and ampere.

TRANSMISSION GEAR OIL

MANUAL TRANSMISSION AND DIFFERENTIAL

2. Transmission Gear Oil

A: INSPECTION

- 1) Park the vehicle on a level surface.
- 2) Turn the ignition switch to OFF, and wait until the engine cools.
- 3) Remove the oil level gauge and wipe it clean.
- 4) Reinsert the level gauge all the way. Be sure that the level gauge is correctly inserted and in the proper direction.
- 5) Pull out the oil level gauge again and check the oil level on it. If it is below the lower level, add oil through the oil level gauge hole to bring the level up to the upper level.

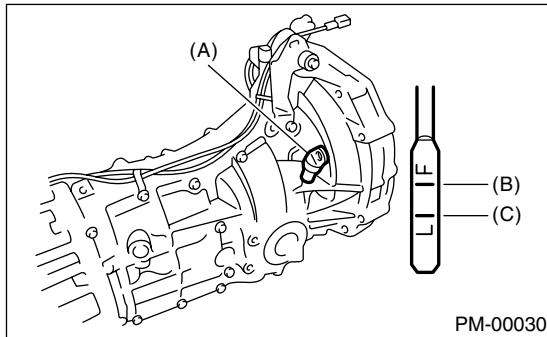

- (A) Oil level gauge
- (B) Upper level
- (C) Lower level

B: REPLACEMENT

- 1) Pull out the oil level gauge.
- 2) Lift-up the vehicle.
- 3) Drain the transmission gear oil completely.

CAUTION:

- **Directly after the engine has been running, the transmission gear oil is hot. Be careful not to burn yourself.**
 - **Be sure not to spill the transmission gear oil on exhaust pipe to prevent it from emitting smoke or firing. When the transmission gear oil is split on exhaust pipe, wipe it away completely.**
- 4) Tighten the transmission gear oil drain plug using a new gasket.

Tightening torque:

44 N·m (4.5 kgf·m, 32.5 ft·lb)

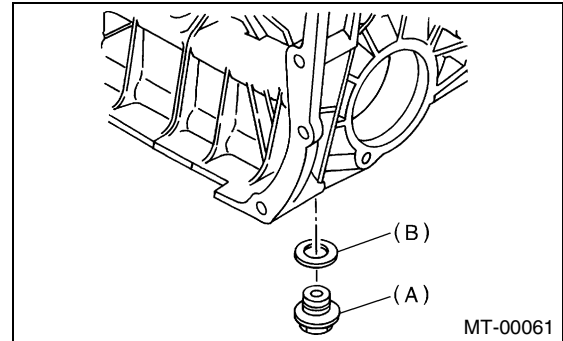

- (A) Drain plug
- (B) Gasket

- 5) Lower the vehicle.
- 6) Pour gear oil into the gauge hole.

Recommended gear oil:

Use GL-5 (75 W — 90) or equivalent.

Gear oil capacity:

Single-range model;

Without oil pump

3.5 ℓ (3.7 US qt, 3.1 Imp qt)

With oil pump

3.9 ℓ (4.1 US qt, 3.4 Imp qt)

Dual-range model;

4.0 ℓ (4.2 US qt, 3.5 Imp qt)

- 7) Measure the level of transmission gear oil, and then check the level within the specified range.

NOTE:

When inserting the level gauge into transmission gear, align the protrusion on the side of the top part of level gauge with the notch in the gauge hole.

MANUAL TRANSMISSION ASSEMBLY

MANUAL TRANSMISSION AND DIFFERENTIAL

3. Manual Transmission Assembly

A: REMOVAL

- 1) Set the vehicle on a lift.
- 2) Disconnect the ground cable from battery.
- 3) Drain the transmission gear oil completely. <Ref. to MT-31, REPLACEMENT, Transmission Gear Oil.>
- 4) Open the front hood fully, and support with stay.
- 5) Remove the air intake duct and air intake chamber. (Non-turbo model) <Ref. to IN(SOHC)-7, REMOVAL, Air Intake Duct.> and <Ref. to IN(SOHC)-6, REMOVAL, Air Cleaner Case.>
- 6) Remove the air cleaner case stay. (Non-turbo model)

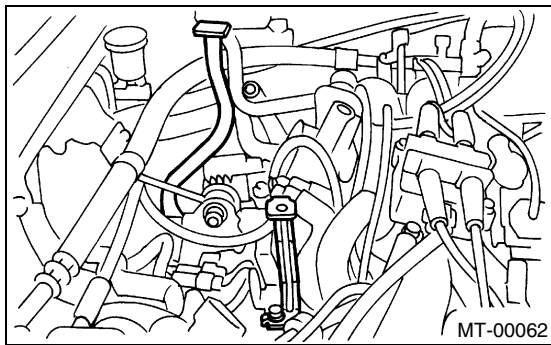

- 7) Remove the intercooler (Turbo model) <Ref. to IN(TURBO)-10, REMOVAL, Intercooler.>
- 8) Disconnect the following connectors and transmission cable.
 - (1) Neutral position switch connector
 - (2) Back-up light switch connector
 - (3) High-low switch connector (Dual-range model)

• NON-TURBO MODEL

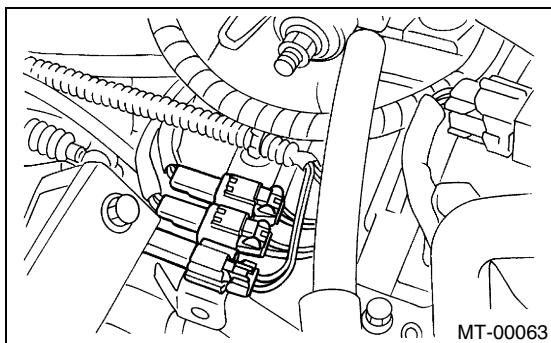

• TURBO MODEL

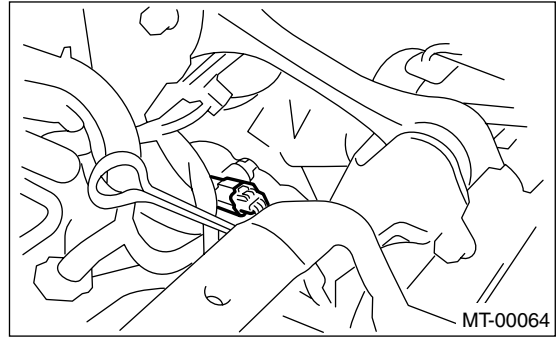

- (4) Vehicle speed sensor

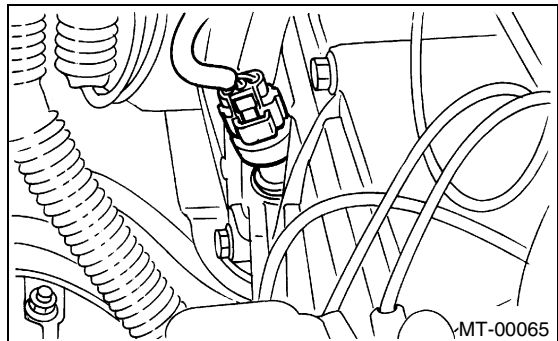

- 9) Remove the snap pin and pin from drive select cable.
- 10) Remove the drive select cable on transmission. (Dual-range model)

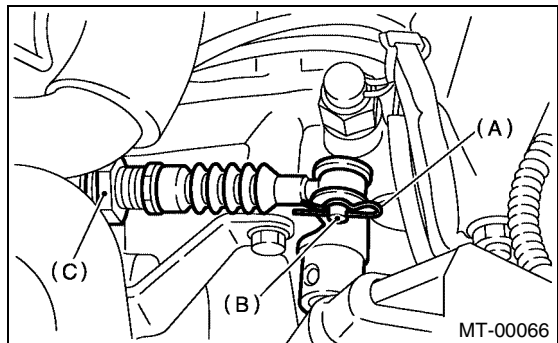

- (A) Snap pin
- (B) Clevis pin
- (C) Drive select cable

- 11) Remove the starter. <Ref. to SC(SOHC)-6, REMOVAL, Starter.>

MANUAL TRANSMISSION ASSEMBLY

MANUAL TRANSMISSION AND DIFFERENTIAL

12) Remove the operating cylinder from transmission, and then hang it with wires.

- NON-TURBO MODEL

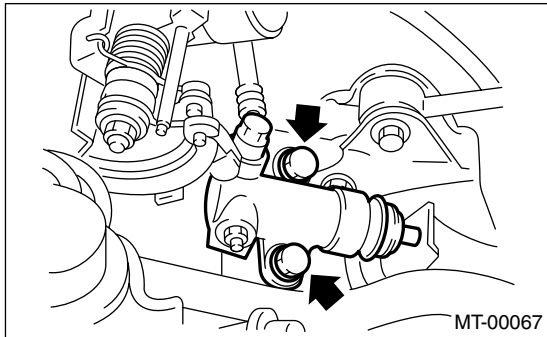

- TURBO MODEL

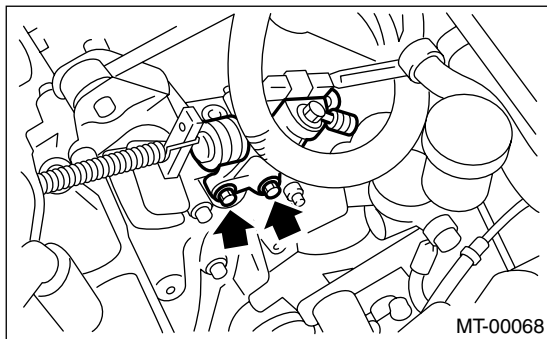

13) Remove the pitching stopper.

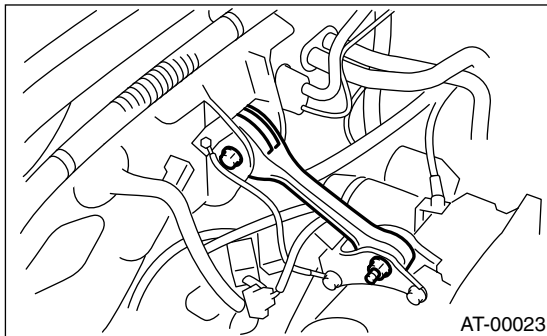

14) Set the ST.

ST 41099AA020 ENGINE SUPPORT ASSY

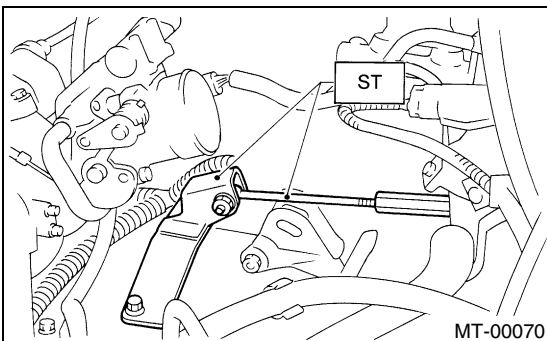

15) Separate the clutch release fork from release bearing. (Turbo model)

(1) Remove the clutch operating cylinder from transmission.

(2) Remove the plug using 10 mm hexagon wrench.

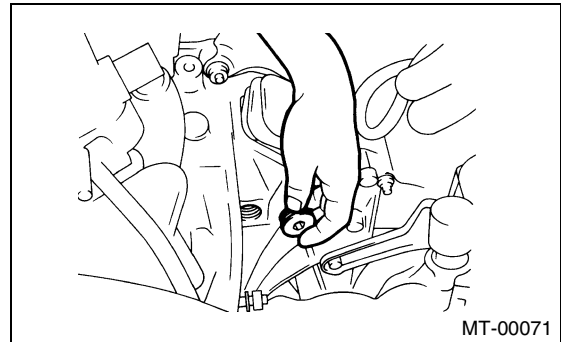

(3) Screw the 6 mm dia. bolt into release fork shaft, and remove it.

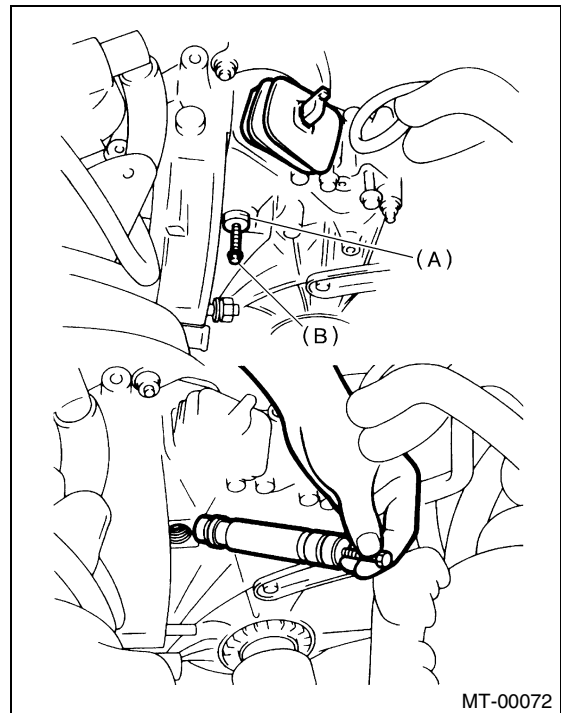

(A) Shaft

(B) Bolt

(4) Raise the release fork and unfasten the release bearing tabs to free release fork.

NOTE:

Step (4) is required to prevent interference with engine when removing the engine from transmission.

MANUAL TRANSMISSION ASSEMBLY

MANUAL TRANSMISSION AND DIFFERENTIAL

16) Remove the bolt which holds right upper side of transmission to engine.

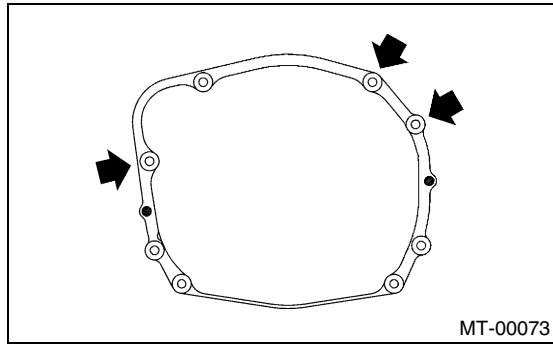

17) Remove the front and center exhaust pipes. (Non-turbo model) <Ref. to EX(SOHC)-7, REMOVAL, Front Exhaust Pipe.>

18) Remove the center exhaust pipe. (Turbo model). <Ref. to EX(TURBO)-7, REMOVAL, Center Exhaust Pipe.>

19) Remove the rear exhaust pipe and muffler.

CAUTION:

When removing the exhaust pipes, be careful each exhaust pipe does not drop out.

20) Remove the heat shield cover. (Non-turbo model only)

21) Remove the hanger bracket from right side of transmission.

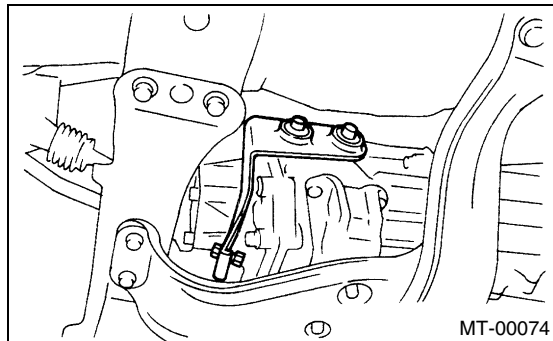

22) Remove the propeller shaft. <Ref. to DS-14, REMOVAL, Propeller Shaft.>

23) Remove the gear shift rod and stay from transmission.

- (1) Disconnect the stay from transmission.
- (2) Disconnect the rod from transmission.

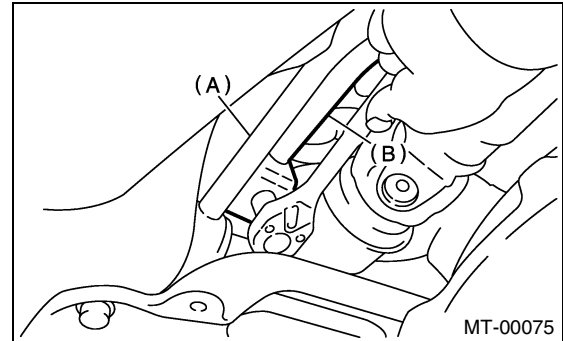

(A) Stay

(B) Rod

24) Disconnect the ATF cooler hose from transmission side oil cooler pipe. (with oil pump)

25) Disconnect the stabilizer link from transverse link.

26) Remove the bolts securing ball joint of transverse link to housing, and then separate the transverse link and housing.

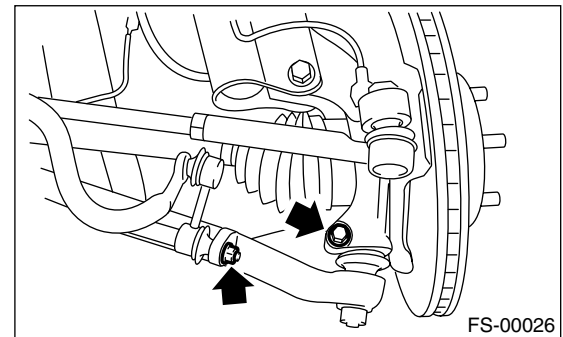

27) Using the ST, remove the front drive shaft from side of transmission case.

NOTE:

- Face the "MT" letter stamped on handle of ST to transmission.

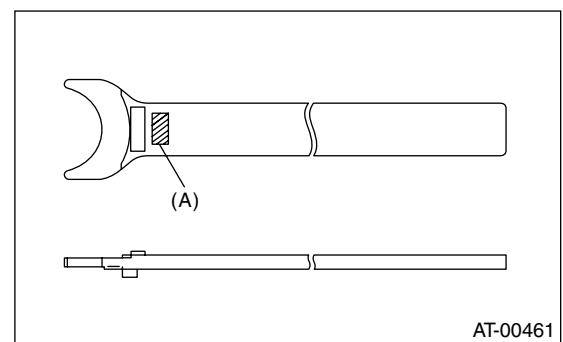

(A) "MT" letter stamped

MANUAL TRANSMISSION ASSEMBLY

MANUAL TRANSMISSION AND DIFFERENTIAL

- Contact the portion of ST to transmission case.
ST 28399SA000 FRONT DRIVE SHAFT REMOVER

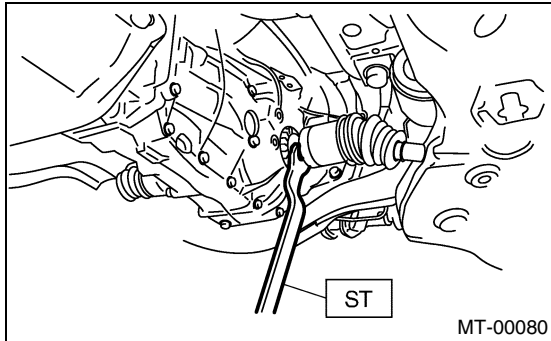

28) While holding the joint portion (AAR) of front drive shaft with your hand, push the housing outside to remove from transmission without stretching AAR side of boot.

29) Remove the nuts which hold lower side of transmission to engine.

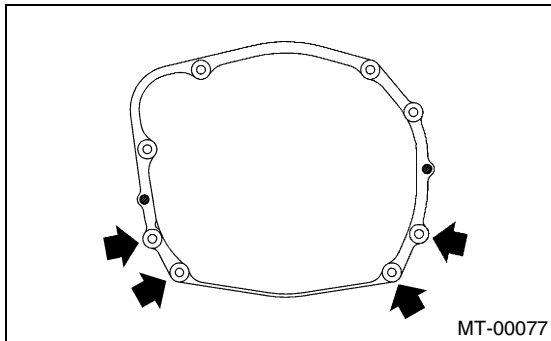

30) Place the transmission jack under transmission.

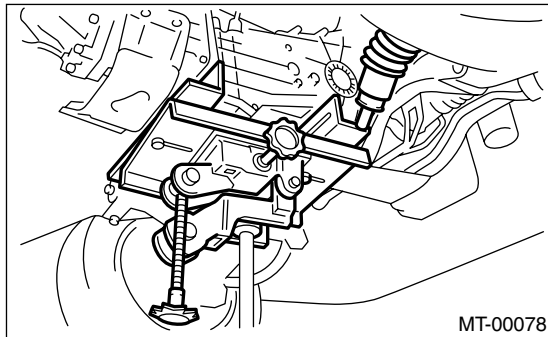

31) Remove the transmission rear crossmember from vehicle.

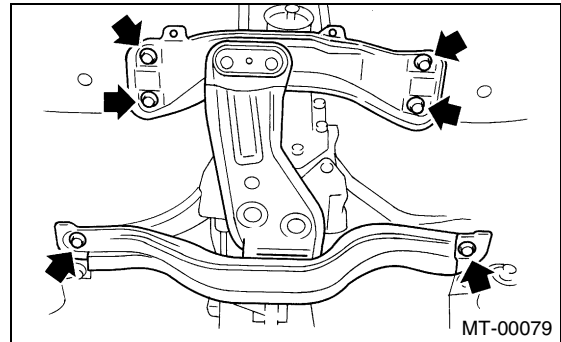

32) Remove the transmission.

NOTE:

Move the transmission jack toward rear until main shaft is withdrawn from clutch cover.

33) Separate the transmission assembly and rear cushion rubber.

B: INSTALLATION

1) Replace the differential side retainer oil seal. <Ref. to MT-42, REPLACEMENT, Differential Side Retainer Oil Seal.>

NOTE:

When pulling out the front drive shaft, always replace the differential side retainer oil seal.

2) Install the rear cushion rubber to transmission assembly.

Tightening torque:

35 N·m (3.57 kgf·m, 25.8 ft·lb)

3) Install the clutch release lever and bearing onto transmission. (Turbo model) <Ref. to CL-23, INSTALLATION, Release Bearing and Lever.>

4) Install the transmission onto engine.

(1) Gradually raise the transmission with transmission jack.

(2) Engage them at splines.

NOTE:

Be careful not to strike the main shaft against clutch cover.

5) Install the transmission rear crossmember.

MANUAL TRANSMISSION ASSEMBLY

MANUAL TRANSMISSION AND DIFFERENTIAL

Tightening torque:

T1: 70 N·m (7.1 kgf-m, 51 ft-lb)

T2: 140 N·m (14.3 kgf-m, 103 ft-lb)

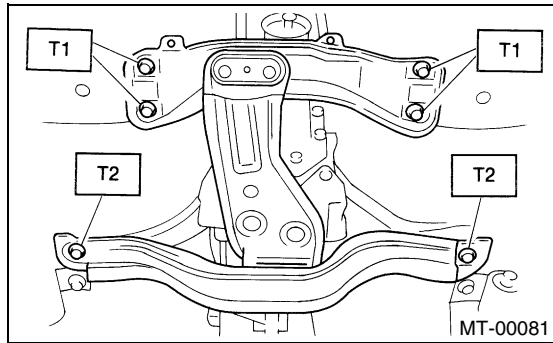

6) Take off the transmission jack.

7) Tighten the nuts which hold lower side of transmission to engine.

Tightening torque:

50 N·m (5.1 kgf-m, 37 ft-lb)

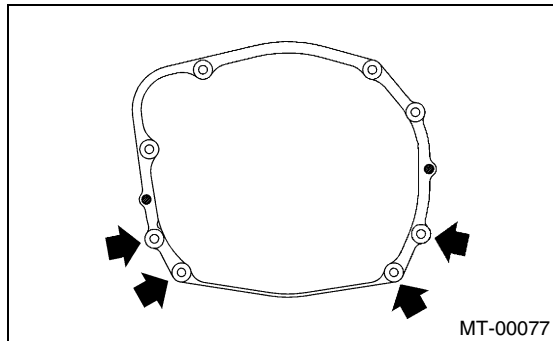

8) Connect the engine and transmission.

(1) Install the starter. <Ref. to SC(SOHC)-6, INSTALLATION, Starter.>

(2) Tighten the bolt which holds right upper side of transmission to engine.

Tightening torque:

50 N·m (5.1 kgf-m, 37 ft-lb)

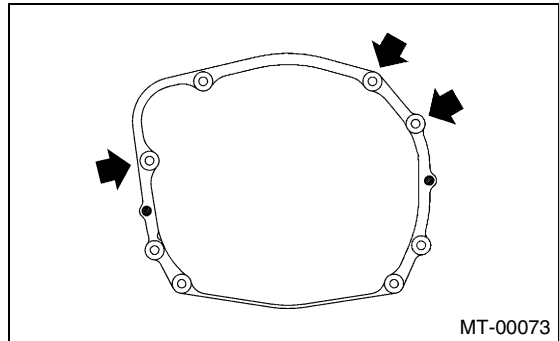

9) Remove the ST.

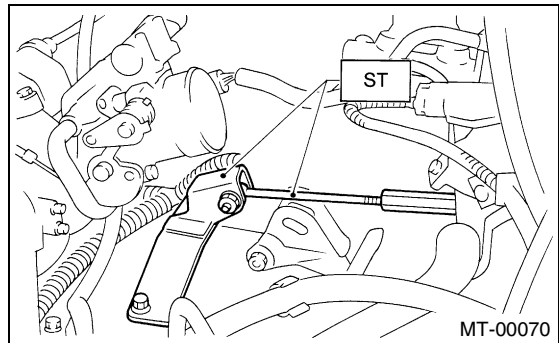

10) Install the pitching stopper.

Tightening torque:

T1: 50 N·m (5.1 kgf-m, 37 ft-lb)

T2: 58 N·m (5.9 kgf-m, 43 ft-lb)

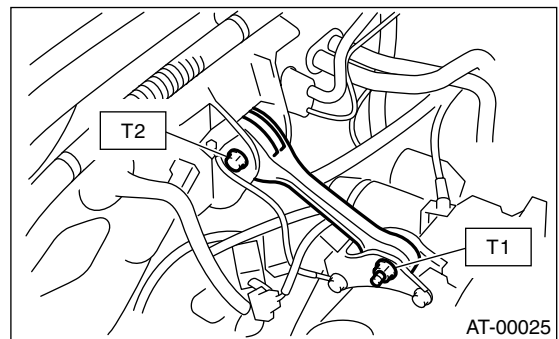

11) Lift-up the vehicle.

12) Install the front drive shaft into transmission.
ST 28399SA010 FRONT DRIVE SHAFT OIL SEAL PROTECTOR

MANUAL TRANSMISSION ASSEMBLY

MANUAL TRANSMISSION AND DIFFERENTIAL

13) Install the ball joints of lower arm into knuckle arm of housing, and tighten the installing bolts.

Tightening torque:

49 N·m (5.0 kgf·m, 36 ft·lb)

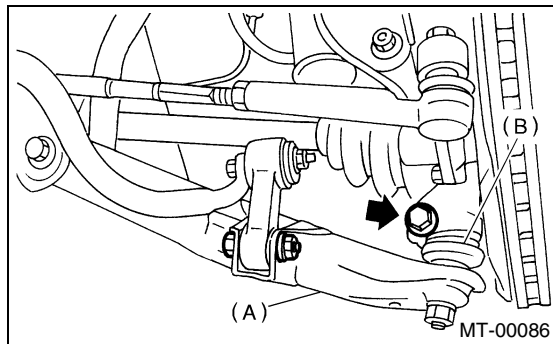

- (A) Transverse link
- (B) Ball joint

14) Install the stabilizer link from transverse link.

Tightening torque:

45 N·m (4.6 kgf·m, 33.2 ft·lb)

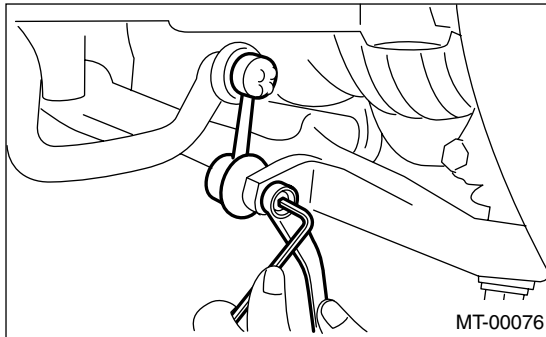

15) Install the gear shift rod and stay.

(1) Install the gear shift rod onto transmission.

Tightening torque:

18 N·m (1.8 kgf·m, 13.0 ft·lb)

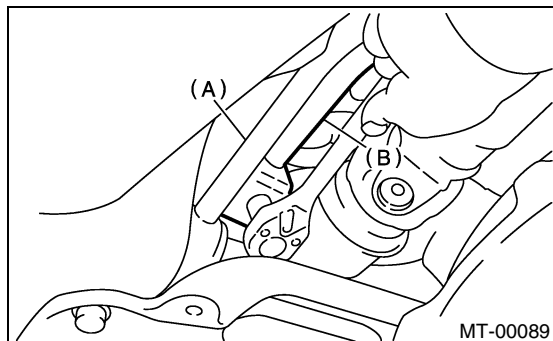

- (A) Stay
- (B) Rod

(2) Install the stay onto transmission.

Tightening torque:

18 N·m (1.8 kgf·m, 13.0 ft·lb)

16) Install the propeller shaft. <Ref. to DS-15, INSTALLATION, Propeller Shaft.>

17) Connect the cooler hose to oil pipe. (with oil pump)

18) Install the heat shield cover. (If equipped)

19) Install the hanger bracket on right side of transmission.

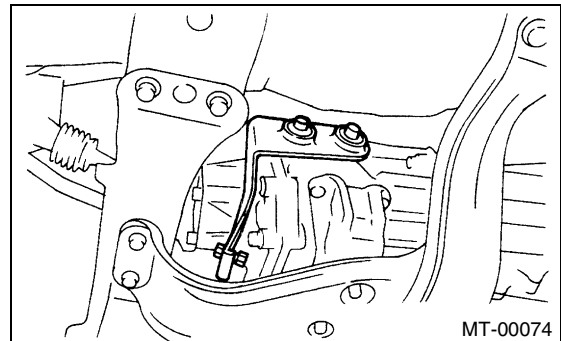

20) Install the rear exhaust pipe and muffler.

21) Install the front exhaust pipe and center exhaust pipe. (Non-turbo model) <Ref. to EX(SOHC)-8, INSTALLATION, Front Exhaust Pipe.>

22) Install the center exhaust pipe. (Turbo model) <Ref. to EX(TURBO)-8, INSTALLATION, Center Exhaust Pipe.>

23) Install the under cover.

24) Push clutch release lever to fit bearing into clutch cover.

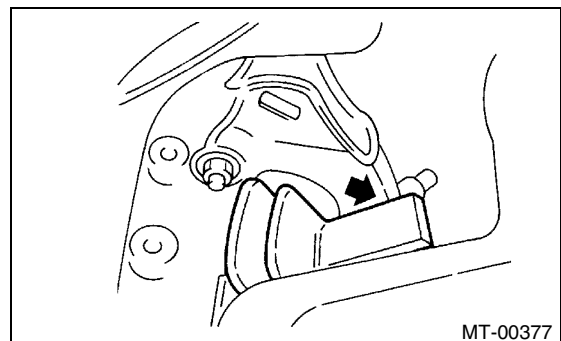

25) Install the operating cylinder.

Tightening torque:

37 N·m (3.8 kgf·m, 27.5 ft·lb)

MANUAL TRANSMISSION ASSEMBLY

MANUAL TRANSMISSION AND DIFFERENTIAL

• NON-TURBO MODEL

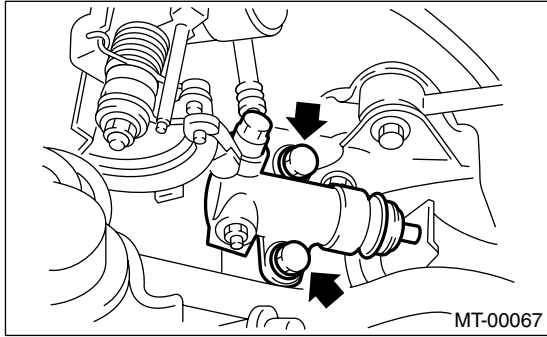

and <Ref. to IN(SOHC)-7, INSTALLATION, Air Intake Duct.>

30) Install the intercooler.(TURBO MODEL) <Ref. to IN(TURBO)-11, INSTALLATION, Intercooler.>

31) Fill gear oil into the gauge hole.

<Ref. to MT-31, REPLACEMENT, Transmission Gear Oil.>

32) Connect the battery ground cable to battery.

33) Take off the vehicle from lift arms.

• TURBO MODEL

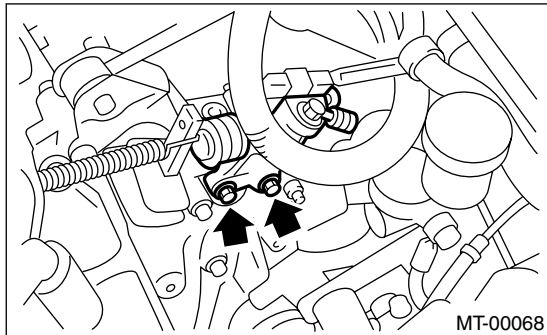

26) Install the drive select cable on transmission.
(Dual-range model)

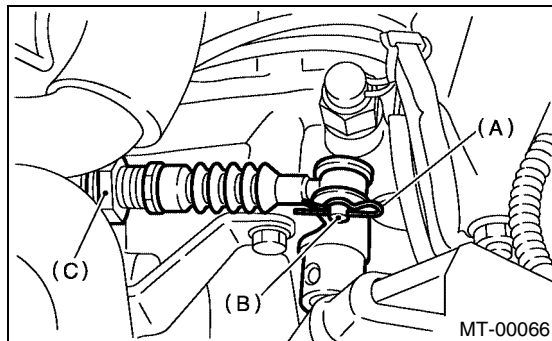

(A) Snap pin

(B) Clevis pin

(C) Drive select cable

27) Connect the following connectors:

(1) Transmission ground cable

Tightening torque:

13 N·m (1.3 kgf·m, 9.4 ft·lb)

(2) Vehicle speed sensor connector

(3) Neutral position switch connector

(4) Back-up light switch connector

(5) High-low switch connector (Dual-range model)

28) Install the air cleaner case stay.

29) Install the air cleaner case and duct. <Ref. to IN(SOHC)-6, INSTALLATION, Air Cleaner Case.>

TRANSMISSION MOUNTING SYSTEM

MANUAL TRANSMISSION AND DIFFERENTIAL

4. Transmission Mounting System

A: REMOVAL

1. PITCHING STOPPER

- 1) Disconnect the ground cable from battery.
- 2) Remove the air intake duct and cleaner case.
- 3) Remove the air intake duct (Non-turbo model). <Ref. to IN(SOHC)-6, REMOVAL, Air Cleaner Case.>
- 4) Remove the air cleaner case (Non-turbo model). <Ref. to IN(SOHC)-7, REMOVAL, Air Intake Duct.>
- 5) Remove the intercooler (Turbo model). <Ref. to IN(TURBO)-10, REMOVAL, Intercooler.>
- 6) Remove the pitching stopper.

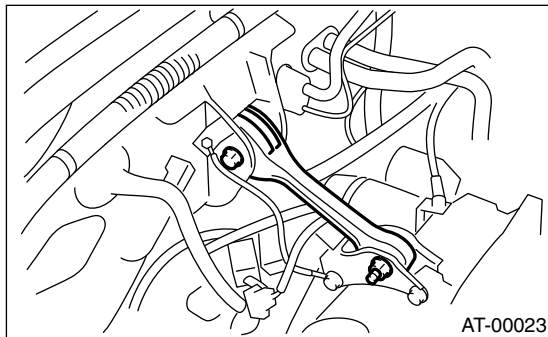

2. CROSSMEMBER AND CUSHION RUBBER

- 1) Disconnect the ground cable from battery.
- 2) Jack-up the vehicle and support it with sturdy racks.
- 3) Remove the front and center exhaust pipes. (Non-turbo model) <Ref. to EX(SOHC)-7, REMOVAL, Front Exhaust Pipe.>
- 4) Remove the center exhaust pipe. (Turbo model) <Ref. to EX(TURBO)-7, REMOVAL, Center Exhaust Pipe.>
- 5) Remove the rear exhaust pipe and muffler.
- 6) Remove the heat shield cover. (If equipped)
- 7) Set the transmission jack under the transmission body.

CAUTION:

Always support the transmission case with a transmission jack.

- 8) Remove the rear crossmember.

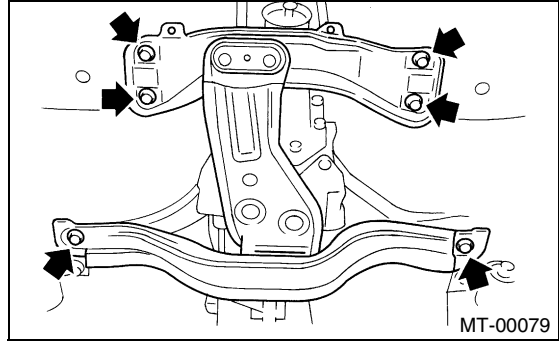

- 9) Remove the rear cushion rubber.

B: INSTALLATION

1. PITCHING STOPPER

- 1) Install the pitching stopper.

Tightening torque:

T1: 50 N·m (5.1 kgf-m, 37 ft-lb)

T2: 58 N·m (5.9 kgf-m, 43 ft-lb)

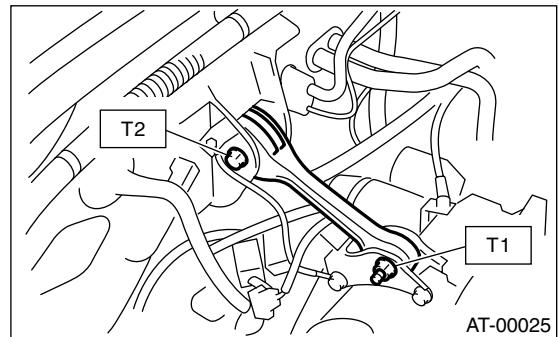

- 2) Install the air intake duct and cleaner case. (Non-turbo model) <Ref. to IN(SOHC)-6, INSTALLATION, Air Cleaner Case.> and <Ref. to IN(SOHC)-7, INSTALLATION, Air Intake Duct.>
- 3) Install the intercooler. (Turbo model) <Ref. to IN(TURBO)-11, INSTALLATION, Intercooler.>
- 4) Connect the battery ground cable to battery.

TRANSMISSION MOUNTING SYSTEM

MANUAL TRANSMISSION AND DIFFERENTIAL

2. CROSSMEMBER AND CUSHION RUBBER

1) Install the rear cushion rubber.

Tightening torque:

35 N·m (3.6 kgf-m, 26 ft-lb)

2) Install the rear crossmember.

Tightening torque:

T1: 70 N·m (7.1 kgf-m, 51 ft-lb)

T2: 140 N·m (14.3 kgf-m, 103 ft-lb)

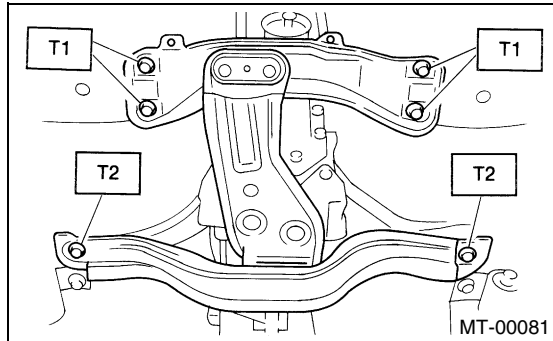

3) Remove the transmission jack.

4) Install the heat shield cover. (If equipped)

5) Install the front and center exhaust pipes. (Non-turbo model)

<Ref. to EX(SOHC)-8, INSTALLATION, Front Exhaust Pipe.>

6) Install the center exhaust pipe. (Turbo model)
<Ref. to EX(TURBO)-8, INSTALLATION, Center Exhaust Pipe.>

7) Install the rear exhaust pipe and muffler.

C: INSPECTION

Repair or replace parts if the results of the inspection below are not satisfactory.

1. PITCHING STOPPER

Make sure that the pitching stopper is not bent or damaged. Make sure that the rubber is not stiff, cracked, or otherwise damaged.

2. CROSSMEMBER AND CUSHION RUBBER

Make sure that the crossmember is not bent or damaged. Make sure that the cushion rubber is not stiff, cracked, or otherwise damaged.

5. Oil Seal

A: INSPECTION

Check the oil seal portion for leakage. If leakage is found, replace the oil seal with a new one.

B: REPLACEMENT

- 1) Clean the transmission exterior.
- 2) Drain the gear oil completely.
- 3) Tighten the drain plug after draining gear oil.

Tightening torque:

44 N·m (4.5 kgf·m, 32.5 ft·lb)

NOTE:

Use a new gasket.

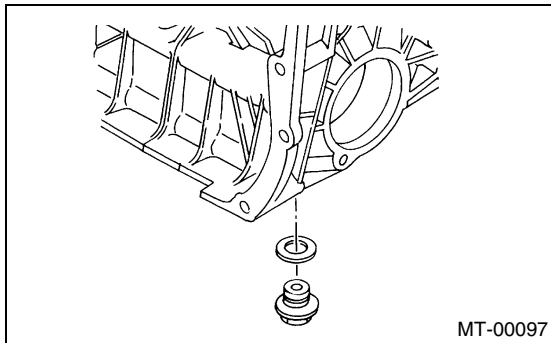

- 4) Remove the rear exhaust pipe and muffler.
- 5) Remove the heat shield cover. (If equipped)
- 6) Remove the propeller shaft. <Ref. to DS-14, REMOVAL, Propeller Shaft.>
- 7) Using the ST, remove the oil seal.
ST 398527700 PULLER ASSY

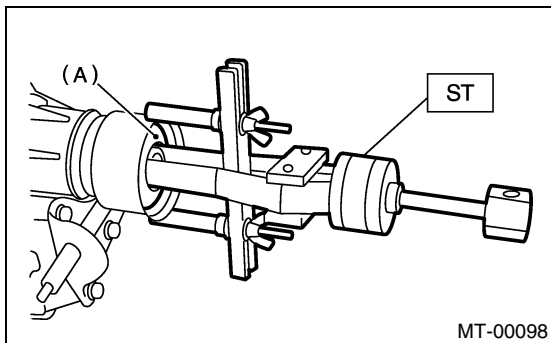

(A) Oil seal

- 8) Using the ST and hammer, install the oil seal.
ST 498057300 INSTALLER

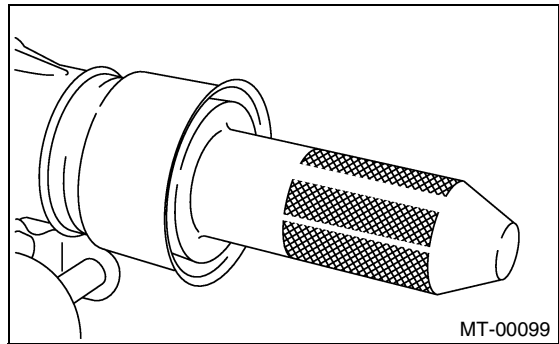

- 9) Install the propeller shaft. <Ref. to DS-15, INSTALLATION, Propeller Shaft.>
- 10) Install the heat shield cover.
- 11) Install the rear exhaust pipe and muffler.
- 12) Pour gear oil and check the oil level. <Ref. to MT-31, REPLACEMENT, Transmission Gear Oil.>

DIFFERENTIAL SIDE RETAINER OIL SEAL

MANUAL TRANSMISSION AND DIFFERENTIAL

6. Differential Side Retainer Oil Seal

A: INSPECTION

Check the differential side retainer oil seal for leakage of gear oil. If oil leaks, replace the oil seal.

B: REPLACEMENT

- 1) Lift-up the vehicle.
- 2) Drain the gear oil from oil drain plug.

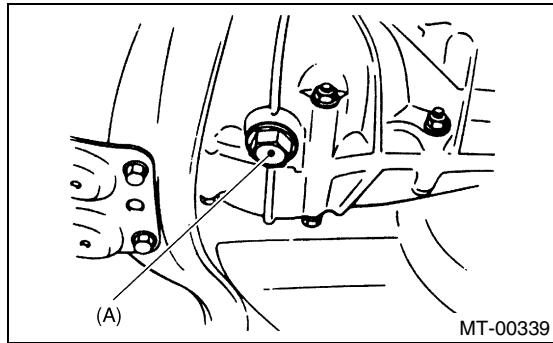

(A) Drain plug

- 3) Replace the gasket with new one, and then tighten the differential oil drain plug.

Tightening torque:

44 N·m (4.5 kgf·m, 32.5 ft·lb)

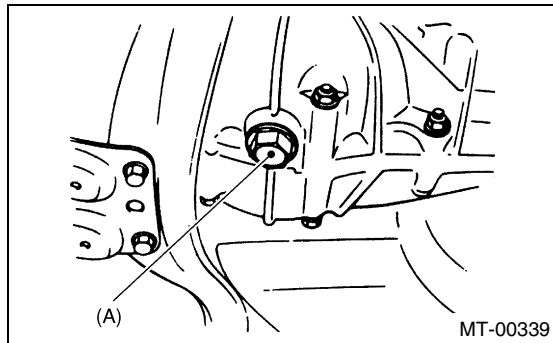

(A) Drain plug

- 4) Remove the front and center exhaust pipe. (Non-turbo model) <Ref. to EX(SOHC)-7, REMOVAL, Front Exhaust Pipe.>
- 5) Separate the front drive shaft from transmission. <Ref. to DS-31, REMOVAL, Front Drive Shaft.>
- 6) Remove the differential side retainer oil seal.

NOTE:

- When pulling out the front drive shaft from transmission, always replace the differential side retainer oil seal.
- Differential side retainer oil seal can be pried off using a vinyl tape ,etc. wrapped flat tip screwdriver. However, make sure not to scratch the differential side retainer portion.

ST 398527700 Puller assembly can also be used for this operation.

- 7) Using the ST, install the differential side retainer oil seal tapping ST lightly with a hammer.

ST 18675AA000 DIFFERENTIAL SIDE OIL SEAL INSTALLER

NOTE:

Be sure to apply oil to oil seal lip surface.

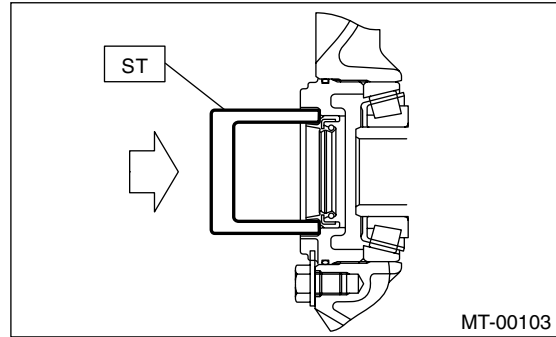

- 8) Install the front drive shaft. <Ref. to DS-32, INSTALLATION, Front Drive Shaft.>

ST 28399SA010 FRONT DRIVE SHAFT OIL SEAL PROTECTOR

- 9) Install the front and center exhaust pipe. (Non-turbo model) <Ref. to EX(SOHC)-8, INSTALLATION, Front Exhaust Pipe.>
- 10) Lower the vehicle.

- 11) Fill gear oil into the gauge hole. <Ref. to MT-31, REPLACEMENT, Transmission Gear Oil.>

SWITCHES AND HARNESS

MANUAL TRANSMISSION AND DIFFERENTIAL

7. Switches and Harness

A: REMOVAL

1. BACK-UP LIGHT AND NEUTRAL POSITION SWITCH

- 1) Disconnect the ground cable from battery.
- 2) Remove the air intake duct and cleaner case. (Non-turbo model) <Ref. to IN(SOHC)-6, REMOVAL, Air Cleaner Case.> and <Ref. to IN(SOHC)-7, REMOVAL, Air Intake Duct.>
- 3) Remove the intercooler (Turbo model). <Ref. to IN(TURBO)-10, REMOVAL, Intercooler.>
- 4) Disconnect the connector of back-up light switch and neutral position switch.

• NON-TURBO MODEL

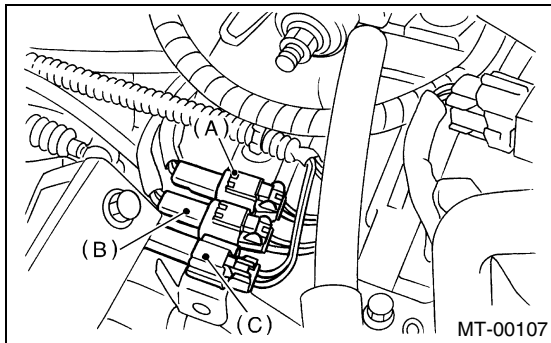

- (A) Neutral switch (Brown)
- (B) Back-up light switch (Gray)
- (C) High-low switch (Black)

• TURBO MODEL

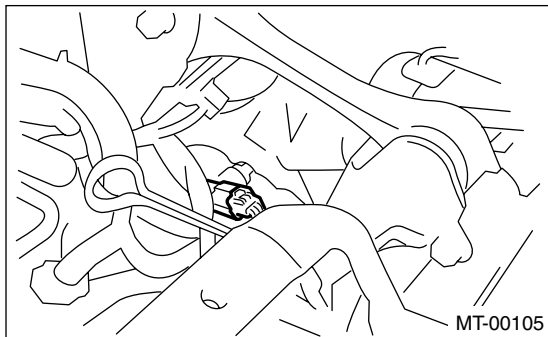

- 5) Lift-up the vehicle.

- 6) Remove the back-up light switch and neutral position switch with harness.

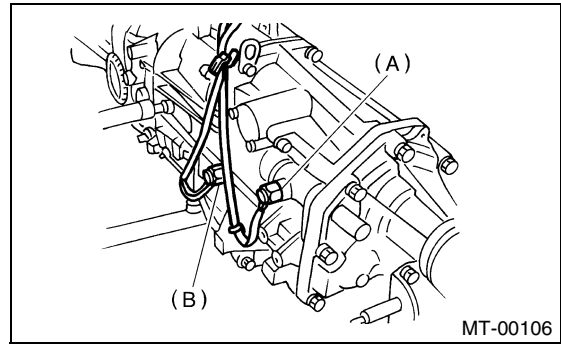

- (A) Neutral switch (Brown connector)
- (B) Back-up light switch (Gray connector)

2. HIGH-LOW SWITCH

- 1) Disconnect the ground cable from battery.
- 2) Remove the air intake duct and cleaner case. <Ref. to IN(SOHC)-6, REMOVAL, Air Cleaner Case.> and <Ref. to IN(SOHC)-7, REMOVAL, Air Intake Duct.>
- 3) Disconnect the connector of high-low switch.

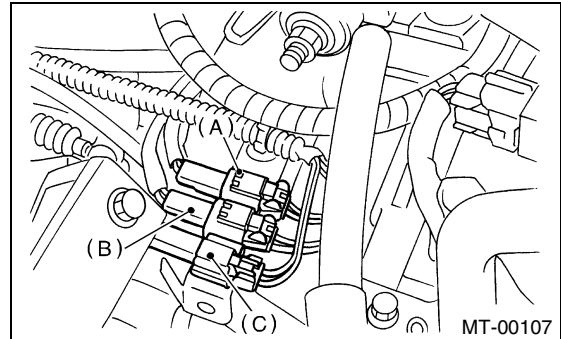

- (A) Neutral switch (Brown)
- (B) Back-up light switch (Gray)
- (C) High-low switch (Black)

- 4) Remove the high-low switch cable from clamp.
- 5) Remove the high-low switch.

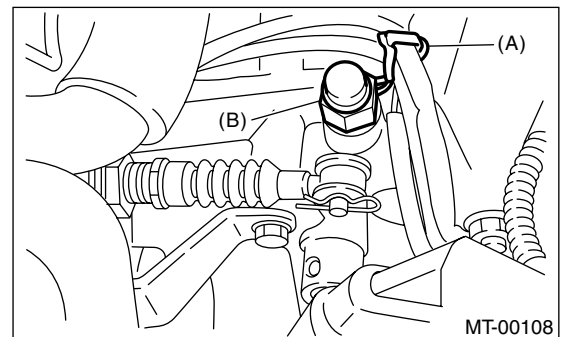

- (A) Clamp
- (B) High-low switch

SWITCHES AND HARNESS

MANUAL TRANSMISSION AND DIFFERENTIAL

B: INSTALLATION

1. BACK-UP LIGHT SWITCH AND NEUTRAL POSITION SWITCH

1) Install the back-up light switch and neutral position switch with harness.

Tightening torque:

25 N·m (2.5 kgf·m, 18.1 ft·lb)

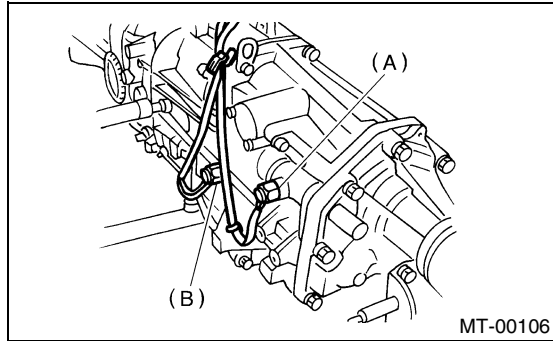

- (A) Neutral switch
- (B) Back-up light switch

2) Connect the connector of back-up light switch and neutral position switch.

3) Install the air intake duct and cleaner case. (Non-turbo model) <Ref. to IN(SOHC)-6, INSTALLATION, Air Cleaner Case.> and <Ref. to IN(SOHC)-7, INSTALLATION, Air Intake Duct.>

4) Install the intercooler. (Turbo model) <Ref. to IN(TURBO)-11, INSTALLATION, Intercooler.>

5) Connect the battery ground cable to battery.

2. HIGH-LOW SWITCH

1) Install the high-low switch.

Tightening torque:

25 N·m (2.5 kgf·m, 18.1 ft·lb)

2) Install the high-low switch cable to clamp.

3) Connect the connector of high-low switch.

4) Install the air intake duct and cleaner case. <Ref. to IN(SOHC)-6, INSTALLATION, Air Cleaner Case.> and <Ref. to IN(SOHC)-7, INSTALLATION, Air Intake Duct.>

5) Connect the battery ground cable to battery.

C: INSPECTION

1. BACK-UP LIGHT SWITCH

Inspect the back-up light switch. <Ref. to LI-7, INSPECTION, Back-up Light System.>

2. NEUTRAL POSITION SWITCH

1) Turn the ignition switch to OFF.

2) Disconnect the connector of neutral position switch.

3) Measure the resistance between neutral position switch terminals.

Non-turbo model:

Gear shift position	Terminal No.	Specified resistance
Neutral position	1 and 2	Less than 1 Ω
Other positions		More than 1 M Ω

Turbo model:

Gear shift position	Terminal No.	Specified resistance
Neutral position	1 and 3	Less than 1 Ω
Other positions		More than 1 M Ω

• NON-TURBO MODEL

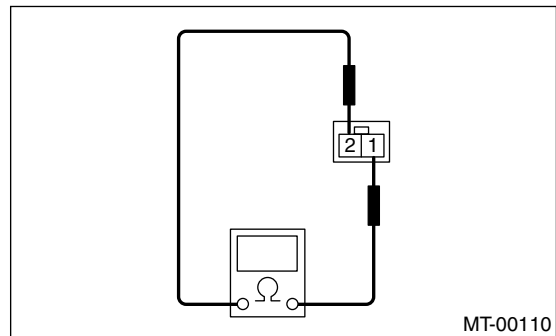

• TURBO MODEL

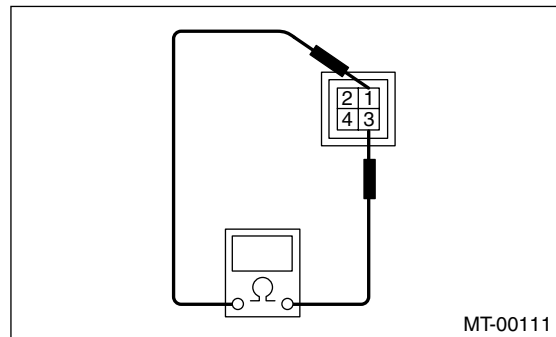

4) Replace the defective parts.

3. HIGH-LOW SWITCH

1) Turn the ignition switch to OFF.

2) Disconnect the connector high-low switch.

3) Measure the resistance between high-low switch terminals.

SWITCHES AND HARNESS

MANUAL TRANSMISSION AND DIFFERENTIAL

Gear shift position	Terminal No.	Specified resistance
LO position	1 and 2	Less than 1 Ω
HIGH position		More than 1 M Ω

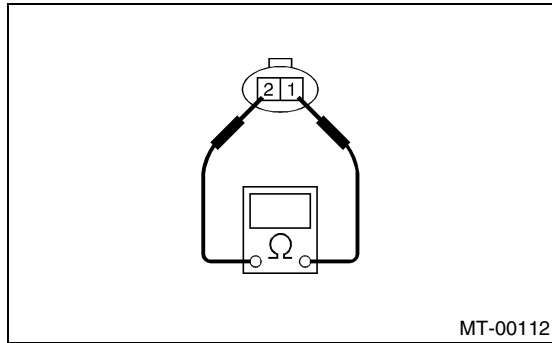

4) Replace the defective parts.

VEHICLE SPEED SENSOR

MANUAL TRANSMISSION AND DIFFERENTIAL

8. Vehicle Speed Sensor

A: REMOVAL

- 1) Disconnect the ground cable from battery.
- 2) Lift-up the vehicle.
- 3) Remove the front, center rear exhaust pipes and muffler.
- 4) Disconnect the connector from vehicle speed sensor.
- 5) Turn and remove the vehicle speed sensor.

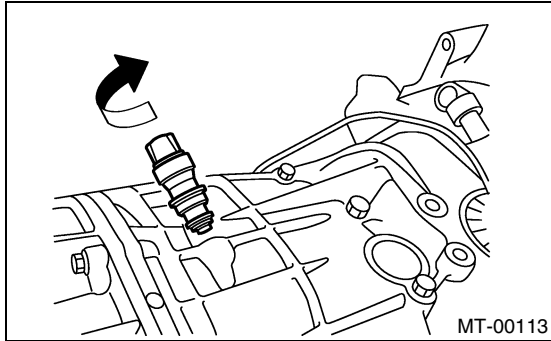

B: INSTALLATION

NOTE:

- Discard the vehicle speed sensor and after removal, replace with a new one.
- Ensure the sensor mounting hole is clean and free of foreign matter.
- Align the tip end of key with key groove on end of speedometer shaft during installation.

- 1) Hand tighten the vehicle speed sensor.
- 2) Tighten the vehicle speed sensor using suitable tool.

Tightening torque:

5.9 N·m (0.6 kgf·m, 4.3 ft·lb)

- 3) Connect the connector to vehicle speed sensor.
- 4) Install the front, center exhaust pipes and muffler.
- 5) Lower the vehicle.
- 6) Connect the battery ground cable to battery.

C: INSPECTION

Inspect the vehicle speed sensor. <Ref. to IDI-6, CHECK VEHICLE SPEED SENSOR, INSPECTION, Combination Meter System.>

PREPARATION FOR OVERHAUL

MANUAL TRANSMISSION AND DIFFERENTIAL

9. Preparation for Overhaul

A: PROCEDURE

- 1) Clean oil, grease, dirt and dust from transmission.
- 2) Remove the drain plug to drain oil. After draining, retighten it as before.
- 3) Tighten the drain plug using new gasket.

Tightening torque:

44 N·m (4.5 kgf·m, 32.5 ft·lb)

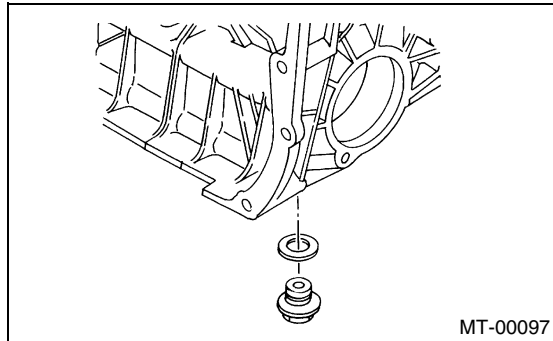

- 4) Remove the outlet pipe. (with oil pump)

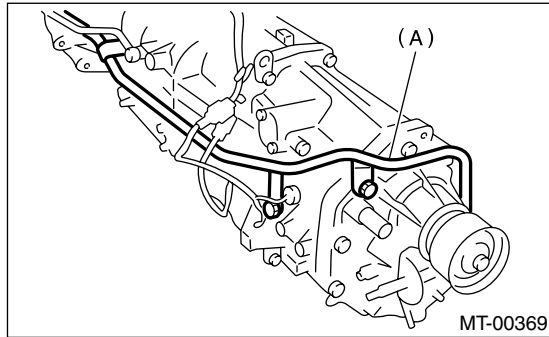

(A) Outlet pipe

- 5) Attach the transmission to ST.
ST 499937100 TRANSMISSION STAND

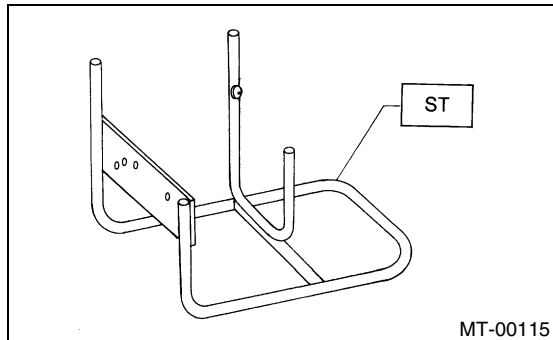

- 6) Rotating parts should be coated with oil prior to assembly.
- 7) All disassembled parts, if to be reused, should be reinstalled in the original positions and directions.

- 8) Gaskets, lock washers and lock nut must be replaced with new ones.
- 9) Liquid gasket should be used where specified to prevent leakage.

OIL PUMP

MANUAL TRANSMISSION AND DIFFERENTIAL

10. Oil Pump

A: REMOVAL

For extension case removal procedure, refer to "Transfer Case and Extension Case Assembly". <Ref. to MT-50, REMOVAL, Transfer Case and Extension Case Assembly.>

B: INSTALLATION

For extension case installation procedure, refer to "Transfer Case Pump and Extension Case Assembly". <Ref. to MT-50, REMOVAL, Transfer Case and Extension Case Assembly.>

C: DISASSEMBLY

- 1) Remove the transfer drive gear assembly. <Ref. to MT-54, REMOVAL, Transfer Drive Gear.>
- 2) Remove the oil strainer from extension case.

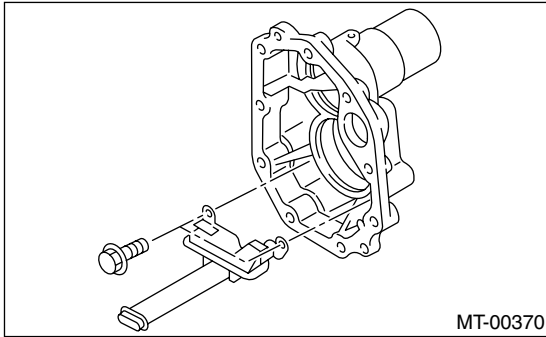

- 3) Remove the shift bracket.

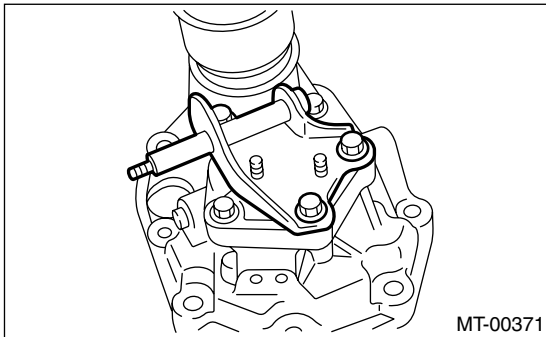

- 4) Remove the relief valve from extension case.

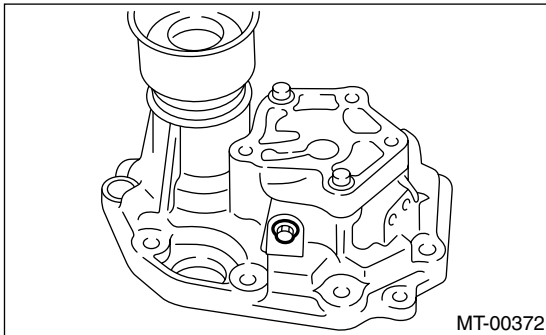

- 5) Remove the oil pump cover from extension.

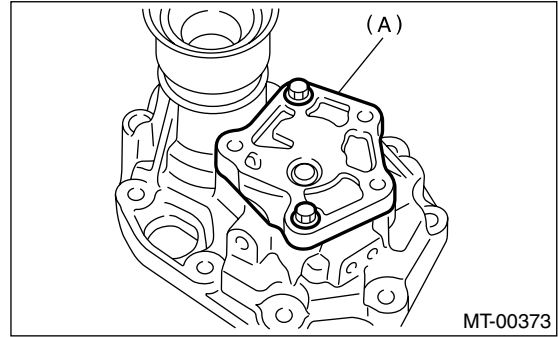

(A) Oil pump cover

- 6) Remove the rotor assembly, oil pump shaft and O-ring.

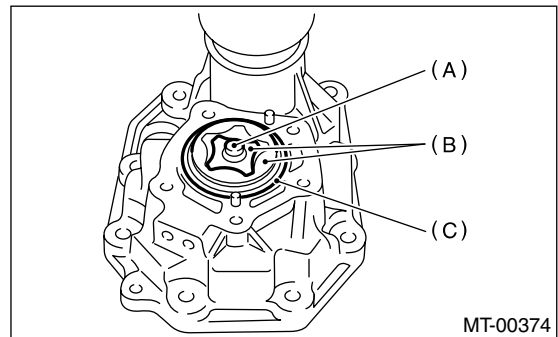

(A) Oil pump shaft
(B) Rotor ASSY
(C) O-ring

D: ASSEMBLY

- 1) Install the rotor assembly and oil pump shaft to extension case.
- 2) Install a new O-ring to oil pump cover.

NOTE:

Apply a coat of gear oil to the O-ring.

- 3) Install the oil pump cover to extension case.

Tightening torque:

24.5 N·m (2.5 kgf·m, 18.1 ft·lb)

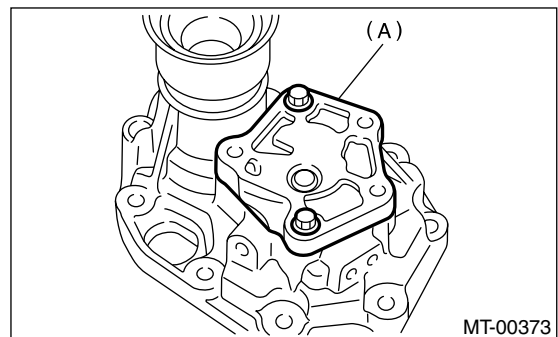

(A) Oil pump cover

OIL PUMP

4) Install a new O-ring, relief valve and return spring to extension case.

Tightening torque:

12.75 N·m (1.3 kgf·m, 9.4 ft·lb)

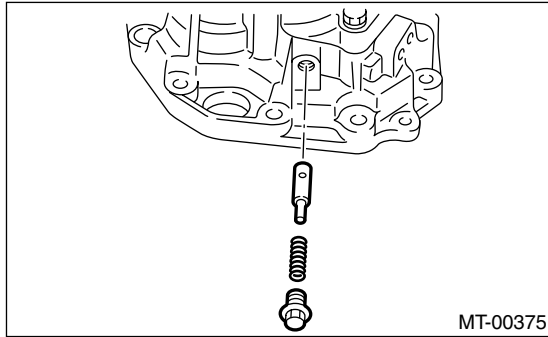

Chip clearance:

Less than 0.15 mm (0.0059 in)

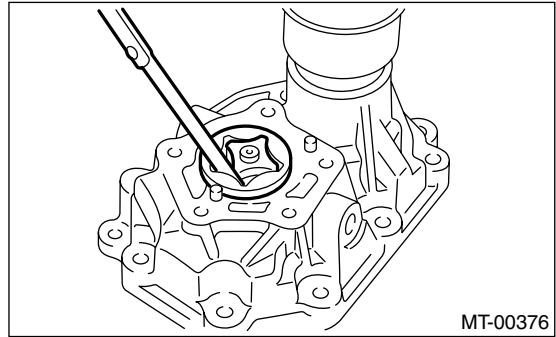

5) Install the shift bracket to extension case.

Tightening torque:

24.5 N·m (2.5 kgf·m, 18.1 ft·lb)

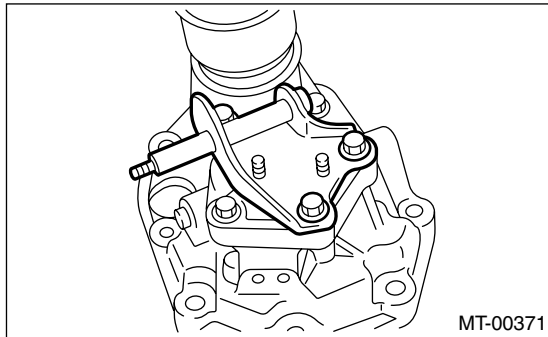

6) Install the oil strainer to extension case.

Tightening torque:

26 N·m (2.7 kgf·m, 19 ft·lb)

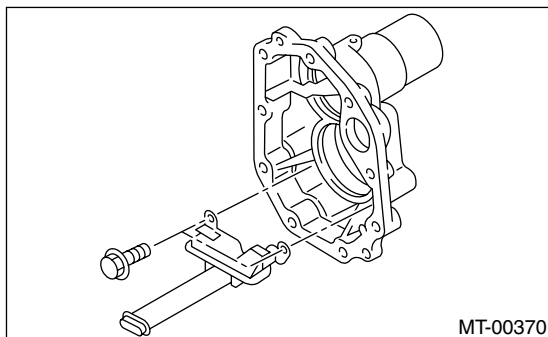

7) Install the transfer drive gear. <Ref. to MT-54, Installation.>

E: INSPECTION

Use a thickness gauge to measure the chip clearance of the rotor assembly. If the value exceeds standard, replace the rotor as an assembly.

TRANSFER CASE AND EXTENSION CASE ASSEMBLY

MANUAL TRANSMISSION AND DIFFERENTIAL

11. Transfer Case and Extension Case Assembly

A: REMOVAL

- 1) Remove the manual transmission assembly from vehicle. <Ref. to MT-32, REMOVAL, Manual Transmission Assembly.>
- 2) Remove the back-up light switch and neutral position switch. <Ref. to MT-43, REMOVAL, Switches and Harness.>
- 3) Remove the transfer case with extension case assembly.

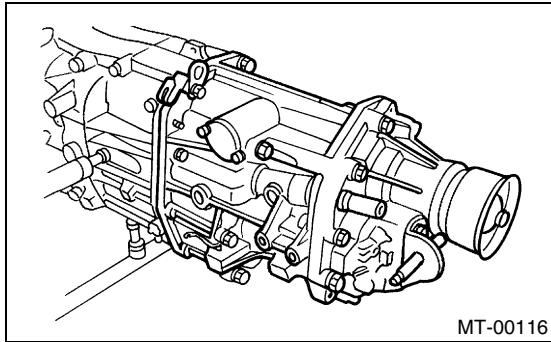

- 4) Remove the shifter arm.
- 5) Remove the extension case assembly.

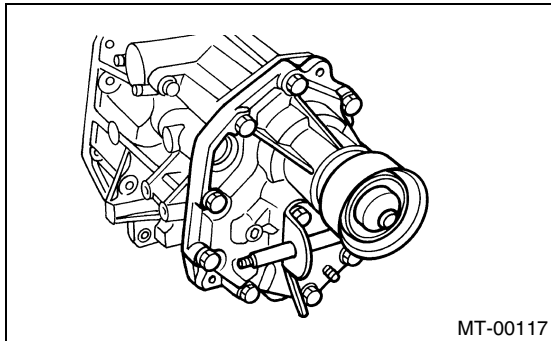

B: INSTALLATION

- 1) Install the center differential and transfer driven gear into transfer case.

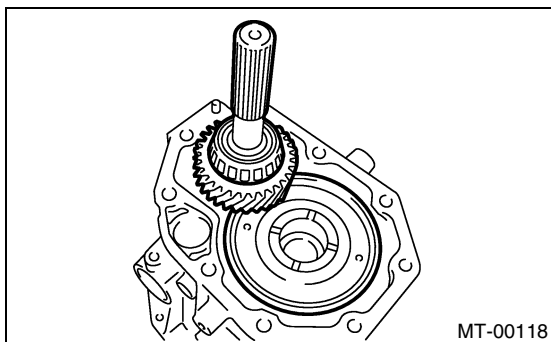

- 2) Remove the bearing cone from bearing of the transfer driven gear.

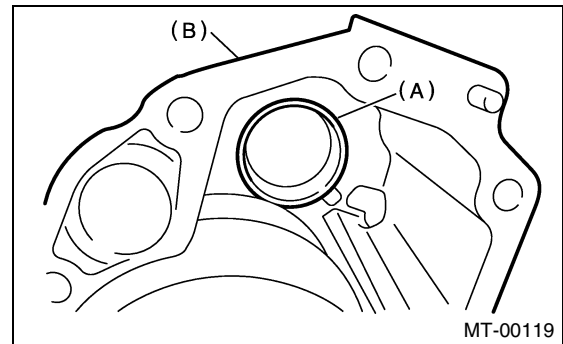

- (A) Bearing cone (Extension case)
(B) Extension case

- 3) While pressing the bearing cone horizontally, turn the driven shaft ten rotations.
- 4) Measure the height "W" between transfer case and taper roller bearing on the transfer driven gear.

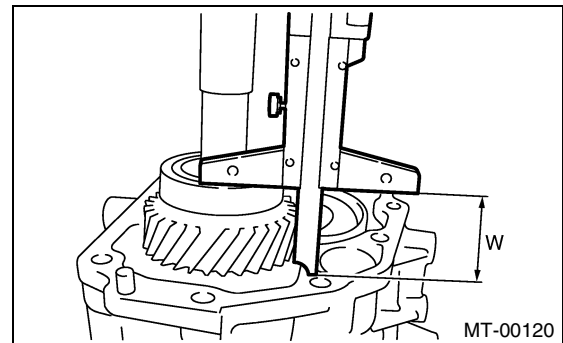

- 5) Measure the depth "X".

NOTE:

Measure with bearing cone and thrust washer removed.

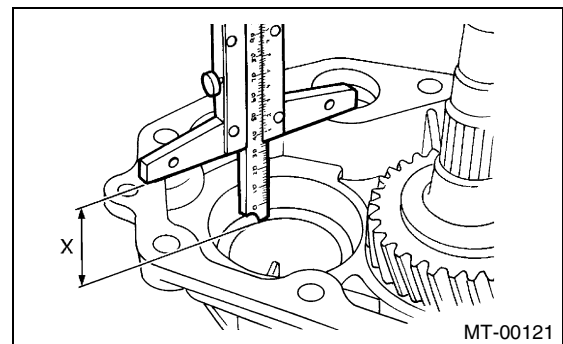

- 6) Calculate the space "t" using the following equation: $t = X - W + 0.2$ to 0.3 mm (0.008 to 0.012 in)

TRANSFER CASE AND EXTENSION CASE ASSEMBLY

MANUAL TRANSMISSION AND DIFFERENTIAL

7) Select the nearest washer in the following table:

Standard clearance between thrust washer and taper roller bearing:

0.2 — 0.3 mm (0.008 — 0.012 in)

NOTE:

Ensure that the clearance is ranged within standard.

Thrust washer (50 × 61 × t)	
Part No.	Thickness mm (in)
803050060	0.50 (0.0197)
803050061	0.55 (0.0217)
803050062	0.60 (0.0236)
803050063	0.65 (0.0256)
803050064	0.70 (0.0276)
803050065	0.75 (0.0295)
803050066	0.80 (0.0315)
803050067	0.85 (0.0335)
803050068	0.90 (0.0354)
803050069	0.95 (0.0374)
803050070	1.00 (0.0394)
803050071	1.05 (0.0413)
803050072	1.10 (0.0433)
803050073	1.15 (0.0453)
803050074	1.20 (0.0472)
803050075	1.25 (0.0492)
803050076	1.30 (0.0512)
803050077	1.35 (0.0531)
803050078	1.40 (0.0551)
803050079	1.45 (0.0571)

8) Fit the thrust washers on transfer drive shaft.

9) Install the bearing cone into extension case.

10) Measure the depth “S” between transfer case and center differential.

ST 398643600 GAUGE

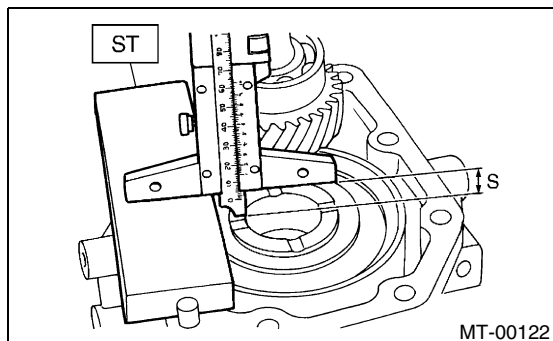

11) Measure the depth “T” between extension case and transfer drive gear.

ST 398643600 GAUGE

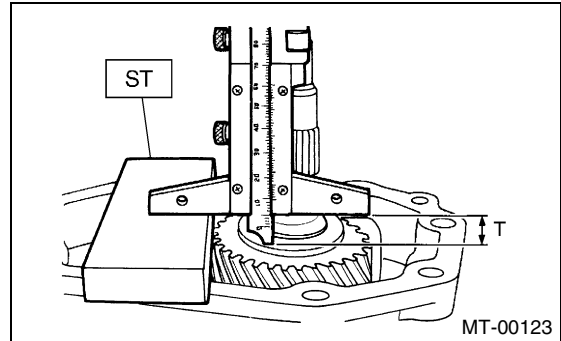

12) Calculate the space “U” using the following equation: $U = S + T - 30 \text{ mm (1.18 in)}$ [Thickness of ST]

13) Select the suitable washer in the following table:

Standard clearance:

0.15 — 0.35 mm (0.0059 — 0.0138 in)

Thrust washer	
Part No.	Thickness mm (in)
803036050	0.9 (0.035)
803036054	1.0 (0.039)
803036051	1.1 (0.043)
803036055	1.2 (0.047)
803036052	1.3 (0.051)
803036056	1.4 (0.055)
803036053	1.5 (0.059)
803036057	1.6 (0.063)
803036058	1.7 (0.067)

14) Fit the thrust washer on center differential.

15) Apply proper amount of liquid gasket to the transfer case mating surface.

Liquid gasket:

THREE BOND 1215 (Parts No. 004403007)

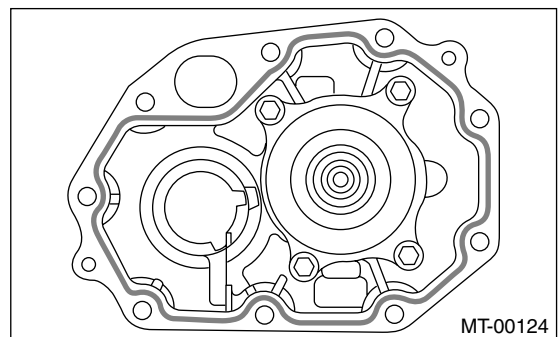

TRANSFER CASE AND EXTENSION CASE ASSEMBLY

MANUAL TRANSMISSION AND DIFFERENTIAL

16) Install the extension assembly into transfer case.

Tightening torque:

40 N·m (4.1 kgf-m, 30 ft-lb)

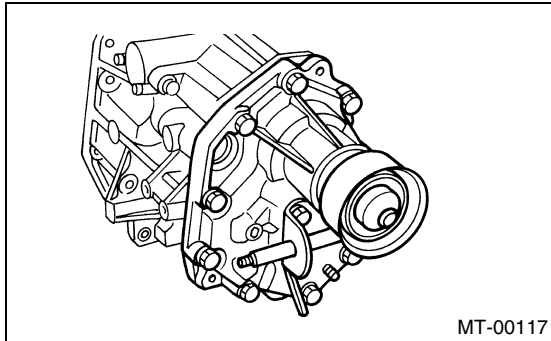

19) Install the transfer case with extension case assembly to transmission case.

Tightening torque:

24.5 N·m (2.5 kgf-m, 18.1 ft-lb)

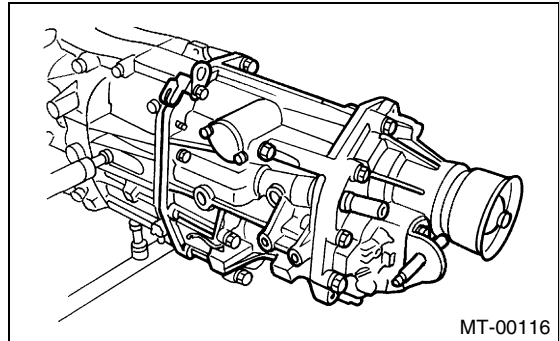

17) Install the shifter arm to transfer case.

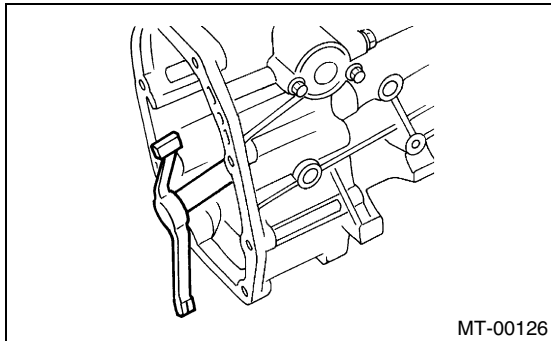

18) Hang the shifter arm on 3rd-4th fork rod.

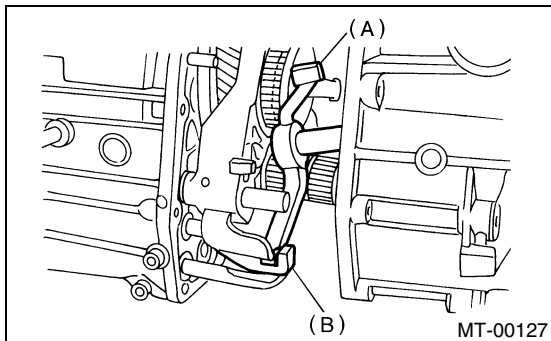

(A) Shifter arm

(B) 3rd-4th fork rod

C: DISASSEMBLY

1. TRANSFER CASE

- 1) Remove the reverse check assembly. <Ref. to MT-59, REMOVAL, Reverse Check Sleeve.>
- 2) Remove the oil guide.

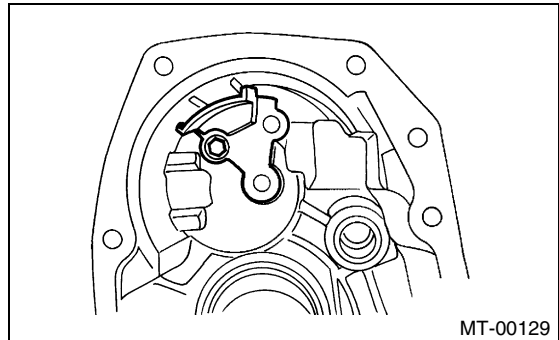

2. EXTENSION CASE

- 1) Remove the transfer drive gear assembly. <Ref. to MT-54, REMOVAL, Transfer Drive Gear.>
- 2) Remove the shift bracket.

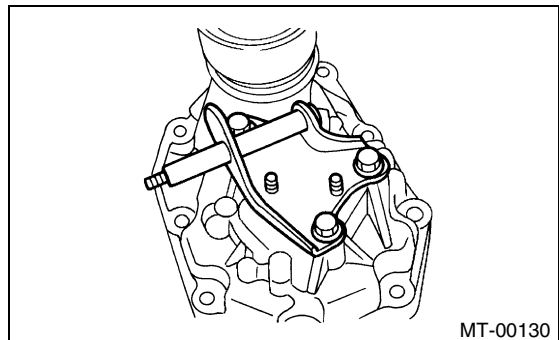

- 3) Remove the oil seal from extension case. <Ref. to MT-41, Oil Seal.>

D: ASSEMBLY

1. EXTENSION CASE

- 1) Using the ST, insert the new oil seal to extension case. <Ref. to MT-41, Oil Seal.>
- 2) Install the shift bracket to extension case.

Tightening torque:

24.5 N·m (2.5 kgf-m, 18.1 ft-lb)

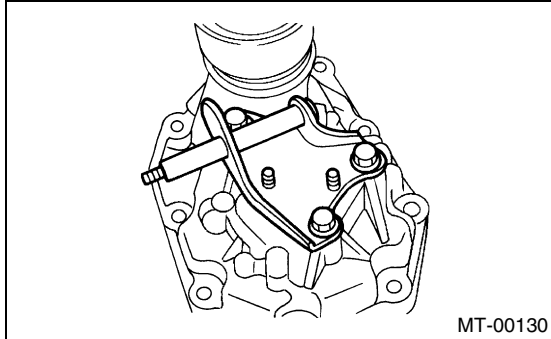

- 3) Install the transfer drive gear to extension case. <Ref. to MT-54, INSTALLATION, Transfer Drive Gear.>

2. TRANSFER CASE

- 1) Install the oil guide to transfer case.

Tightening torque:

6.4 N·m (0.65 kgf-m, 4.7 ft-lb)

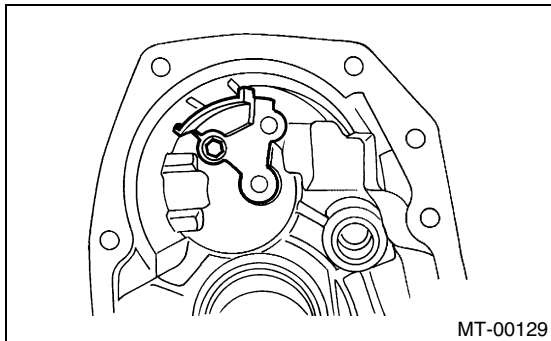

- 2) Install the reverse check sleeve assembly to transfer case. <Ref. to MT-59, INSTALLATION, Reverse Check Sleeve.>

TRANSFER DRIVE GEAR

MANUAL TRANSMISSION AND DIFFERENTIAL

12. Transfer Drive Gear

A: REMOVAL

- 1) Remove the manual transmission assembly from vehicle. <Ref. to MT-32, REMOVAL, Manual Transmission Assembly.>
- 2) Remove the back-up light switch and neutral position switch. <Ref. to MT-43, REMOVAL, Switches and Harness.>
- 3) Remove the transfer case with extension case assembly. <Ref. to MT-50, REMOVAL, Transfer Case and Extension Case Assembly.>
- 4) Remove the extension case assembly.
- 5) Remove the transfer driven gear.
- 6) Remove the transfer drive gear.

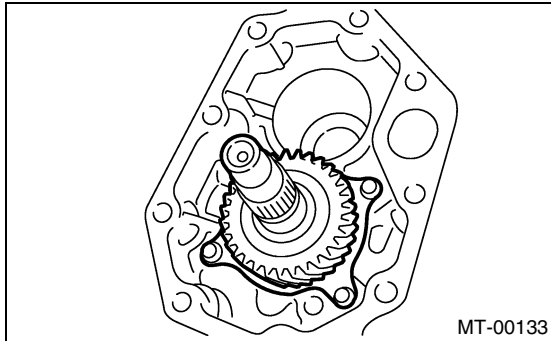

B: INSTALLATION

- 1) Install the transfer drive gear.

Tightening torque:

26 N·m (2.7 kgf·m, 20 ft·lb)

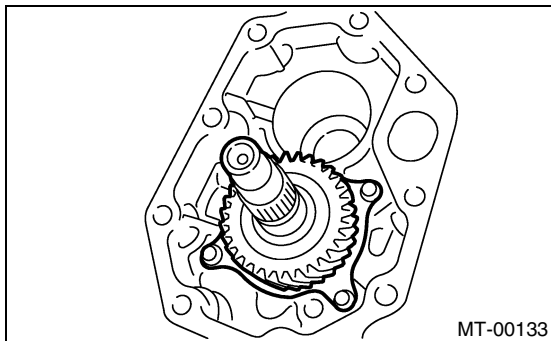

- 2) Install the transfer driven gear.
- 3) Install the extension case assembly.
- 4) Install the transfer case and extension case assembly. <Ref. to MT-50, INSTALLATION, Transfer Case and Extension Case Assembly.>
- 5) Install the back-up light switch and neutral position switch. <Ref. to MT-44, INSTALLATION, Switches and Harness.>
- 6) Install the manual transmission assembly from vehicle. <Ref. to MT-35, INSTALLATION, Manual Transmission Assembly.>

C: DISASSEMBLY

- 1) Remove the snap ring.

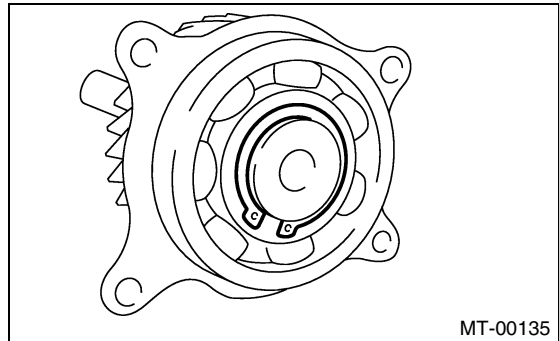

- 2) Remove the ball bearing.

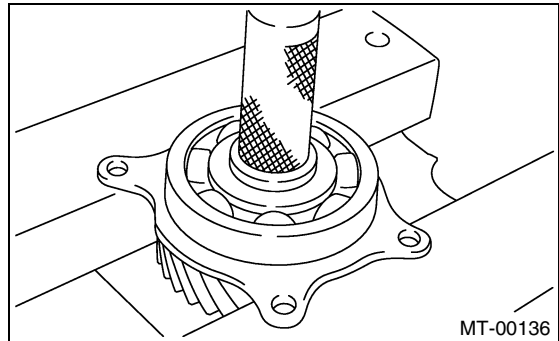

D: ASSEMBLY

- 1) Set the ST applying to inner race of bearing and install to drive shaft.

ST 398177700 INSTALLER

NOTE:

Do not apply pressure in excess of 10 kN (1 ton, 1.1 US ton, 1.0 Imp ton)

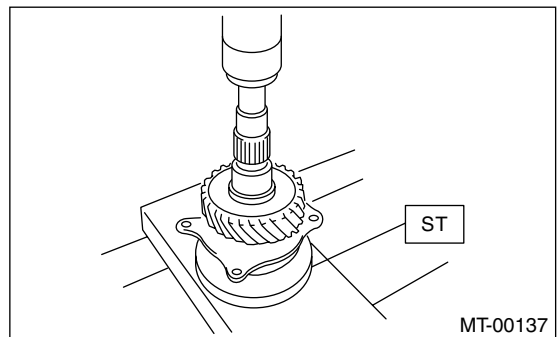

- 2) Install the snap ring on transfer drive shaft.
- 3) Check the clearance between snap ring and ball bearing. <Ref. to MT-55, INSPECTION, Transfer Drive Gear.>

E: INSPECTION

1) Bearings

Replace the bearings in the following cases:

- Broken or rusty bearings
- Worn or damaged
- Bearings that fail to turn smoothly or make abnormal noise when turned after gear oil lubrication.

2) Drive gear

Replace the drive gear in the following cases:

- If their tooth surfaces and shaft are excessively broken or damaged.

3) Measure the clearance between snap ring and inner race of ball bearing with a thickness gauge.

Clearance:

0.01 — 0.15 mm (0.0004 — 0.0059 in)

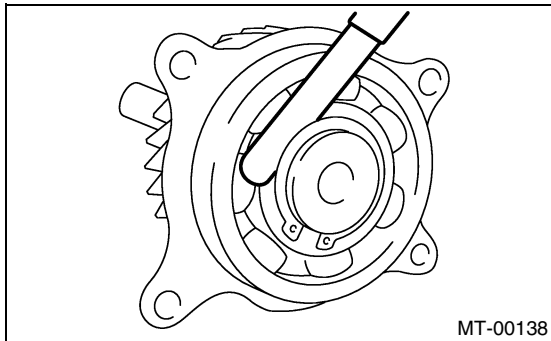

If the measurement is not within specification, select a suitable snap ring.

Snap ring (Outer-30)	
Part No.	Thickness mm (in)
805030041	1.53 (0.0602)
805030042	1.65 (0.0650)
805030043	1.77 (0.0697)

TRANSFER DRIVEN GEAR

MANUAL TRANSMISSION AND DIFFERENTIAL

13. Transfer Driven Gear

A: REMOVAL

- 1) Remove the manual transmission assembly from vehicle. <Ref. to MT-32, REMOVAL, Manual Transmission Assembly.>
- 2) Remove the back-up light switch and neutral position switch. <Ref. to MT-43, REMOVAL, Switches and Harness.>
- 3) Remove the transfer case with extension case assembly. <Ref. to MT-50, REMOVAL, Transfer Case and Extension Case Assembly.>
- 4) Remove the extension case assembly.
- 5) Remove the transfer driven gear.

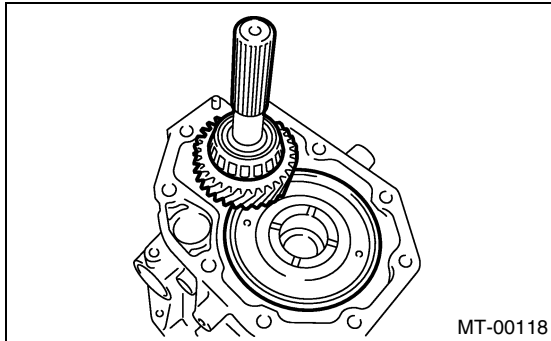

- 6) Remove the bearing outer race from extension case and transfer case.

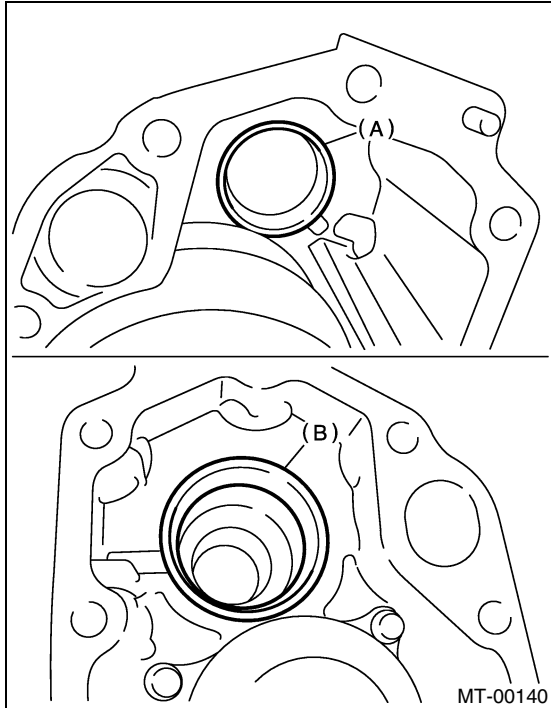

- (A) Bearing outer race (transfer case)
- (B) Bearing outer race (extension case)

B: INSTALLATION

- 1) Install the bearing outer race to extension case and transfer case.

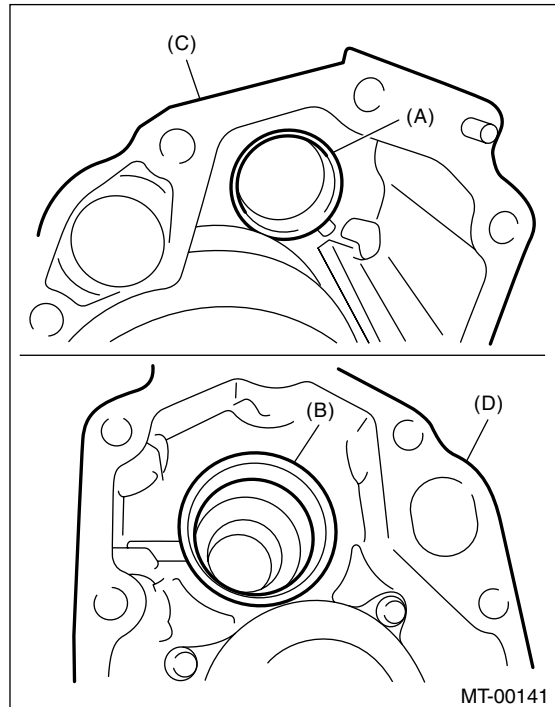

- (A) Bearing outer race
- (B) Bearing outer race
- (C) Transfer case
- (D) Extension case

- 2) Install the transfer driven gear.

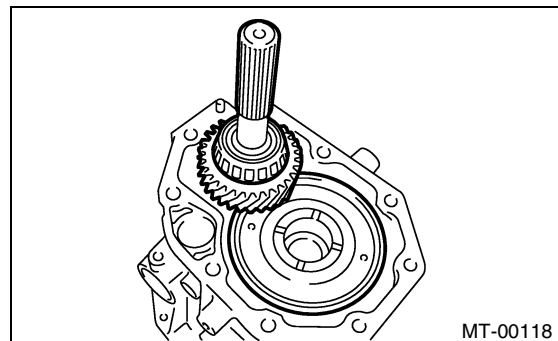

- 3) Install the transfer case and extension case assembly. <Ref. to MT-50, INSTALLATION, Transfer Case and Extension Case Assembly.>
- 4) Install the back-up light switch and neutral position switch. <Ref. to MT-44, INSTALLATION, Switches and Harness.>
- 5) Install the manual transmission assembly to vehicle. <Ref. to MT-35, INSTALLATION, Manual Transmission Assembly.>

TRANSFER DRIVEN GEAR

MANUAL TRANSMISSION AND DIFFERENTIAL

C: DISASSEMBLY

1) Using the ST, remove the roller bearing (extension case side).

ST 498077000 REMOVER

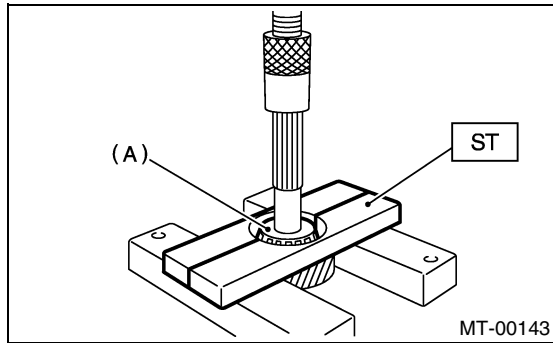

(A) Roller bearing

2) Using the ST1 and ST2, remove the roller bearing (transfer case side).

ST1 498077000 REMOVER

ST2 899864100 REMOVER

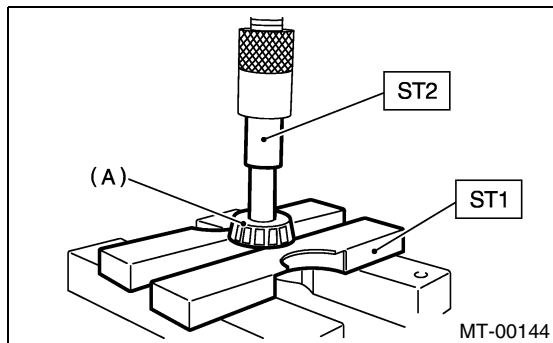

(A) Roller bearing

D: ASSEMBLY

1) Using the ST, install the roller bearing (extension case side).

ST1 398177700 INSTALLER

ST2 899864100 REMOVER

NOTE:

Do not apply pressure in excess of 10 kN (1 ton, 1.1 US ton, 1.0 Imp ton)

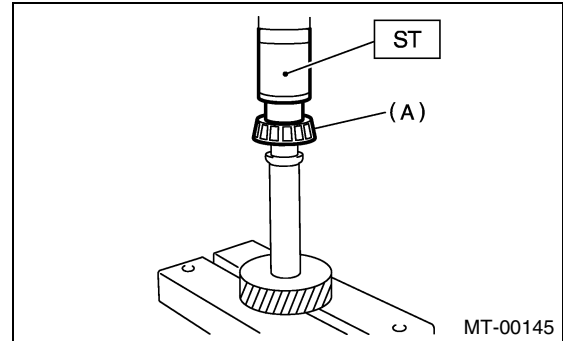

(A) Roller bearing

2) Using the ST, install the roller bearing (transfer case side).

ST 499757002 INSTALLER

NOTE:

Do not apply pressure in excess of 10 kN (1 ton, 1.1 US ton, 1.0 Imp ton)

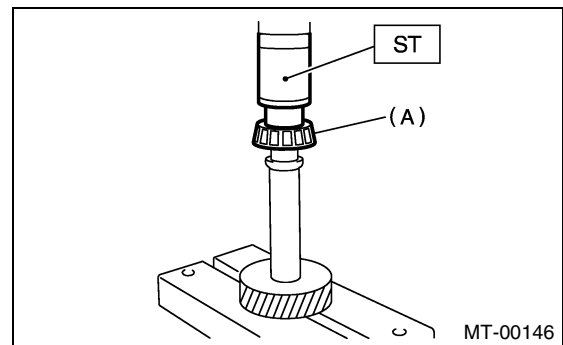

(A) Roller bearing

E: INSPECTION

1) Bearings

Replace the bearings in the following cases:

- Broken or rusty bearings
- Worn or damaged
- Bearings that fail to turn smoothly or make abnormal noise when turned after gear oil lubrication.

2) Driven gear

Replace the drive gear in the following cases:

- If their tooth surfaces and shaft are excessively broken or damaged.

CENTER DIFFERENTIAL

MANUAL TRANSMISSION AND DIFFERENTIAL

14.Center Differential

A: REMOVAL

- 1) Remove the manual transmission assembly from vehicle. <Ref. to MT-32, REMOVAL, Manual Transmission Assembly.>
- 2) Remove the transfer case with extension case assembly.<Ref. to MT-50, REMOVAL, Transfer Case and Extension Case Assembly.>
- 3) Remove the extension case assembly. <Ref. to MT-50, REMOVAL, Transfer Case and Extension Case Assembly.>
- 4) Remove the transfer driven gear. <Ref. to MT-56, REMOVAL, Transfer Driven Gear.>
- 5) Remove the center differential.

B: INSTALLATION

- 1) Install the center differential into transfer case.
- 2) Install the transfer driven gear. <Ref. to MT-56, INSTALLATION, Transfer Driven Gear.>
- 3) Install the extension case assembly. <Ref. to MT-50, INSTALLATION, Transfer Case and Extension Case Assembly.>
- 4) Install the transfer case with extension case assembly. <Ref. to MT-50, REMOVAL, Transfer Case and Extension Case Assembly.>
- 5) Install the back-up light switch and neutral position switch. <Ref. to MT-43, REMOVAL, Switches and Harness.>
- 6) Install the manual transmission assembly to vehicle. <Ref. to MT-35, INSTALLATION, Manual Transmission Assembly.>

C: DISASSEMBLY

- 1) Remove the ball bearing using ST.

NOTE:

Do not reuse the ball bearing.

ST 498077300 CENTER DIFFERENTIAL BEARING REMOVER

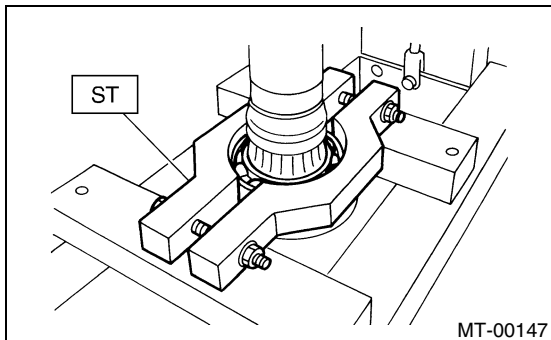

- 2) Do not disassemble the center differential except ball bearing part because it is a non-disassemble part.

D: ASSEMBLY

Install the ball bearing to center differential assembly.

NOTE:

Do not apply pressure in excess of 10 kN (1 ton, 1.1 US ton, 1.0 Imp ton).

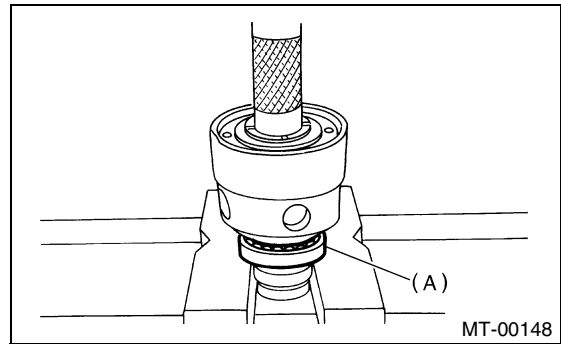

(A) Ball bearing

E: INSPECTION

- 1) Bearings

Replace the bearings in the following cases:

- Broken or rusty bearings
- Worn or damaged
- Bearings that fail to turn smoothly or make abnormal noise when turned after gear oil lubrication.
- Bearings having other defects

- 2) Center differential

Replace the center differential assembly in the following case:

- Worn or damaged

REVERSE CHECK SLEEVE

MANUAL TRANSMISSION AND DIFFERENTIAL

15.Reverse Check Sleeve

A: REMOVAL

- 1) Remove the manual transmission assembly from vehicle. <Ref. to MT-32, REMOVAL, Manual Transmission Assembly.>
- 2) Remove the transfer case with extension case assembly. <Ref. to MT-50, REMOVAL, Transfer Case and Extension Case Assembly.>
- 3) Remove the shifter arm.
- 4) Remove the plug, spring washer and reverse check ball.

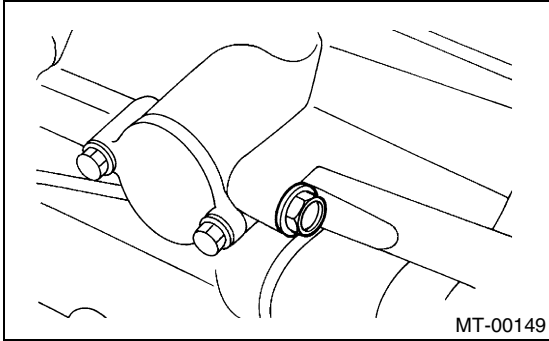

- 5) Remove the reverse check sleeve.

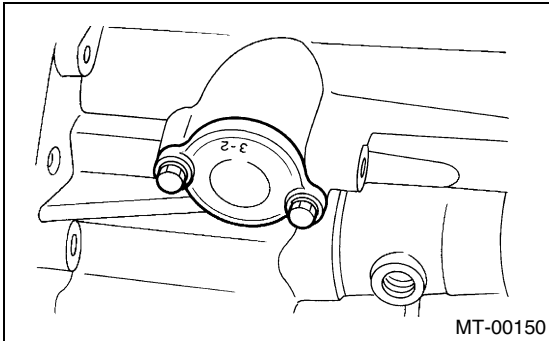

B: INSTALLATION

- 1) Install the reverse check sleeve.

Tightening torque:

6.4 N·m (0.65 kgf-m, 4.7 ft-lb)

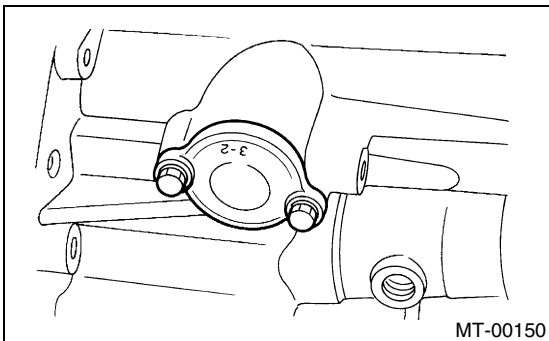

- 2) Install the ball, spring, washer and plug to transfer case.

Tightening torque:

9.75 N·m (1.0 kgf-m, 7.2 ft-lb)

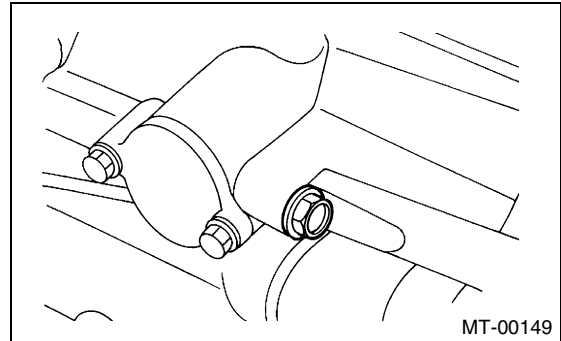

- 3) Install the shifter arm to transfer case assembly.
- 4) Install the transfer case with extension case assembly. <Ref. to MT-50, INSTALLATION, Transfer Case and Extension Case Assembly.>
- 5) Install the manual transmission assembly to vehicle. <Ref. to MT-35, INSTALLATION, Manual Transmission Assembly.>

C: DISASSEMBLY

- 1) Cover the reverse check sleeve with a rag, and remove the snap ring using a flat tip screwdriver.

NOTE:

Replace the snap ring with a new one if deformed or weakened.

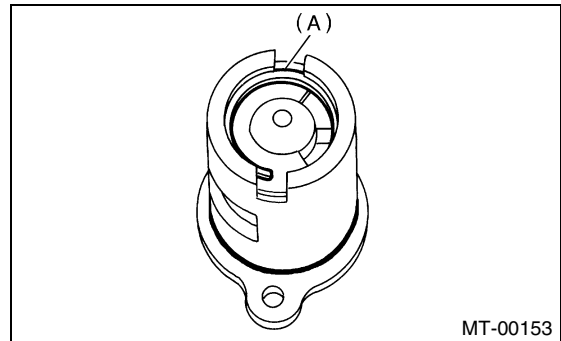

(A) Snap ring

REVERSE CHECK SLEEVE

MANUAL TRANSMISSION AND DIFFERENTIAL

2) Remove the reverse check plate, reverse check spring, reverse check cam, return spring (5th-Rev), reverse accent shaft, return spring cap and return spring (1st-2nd).

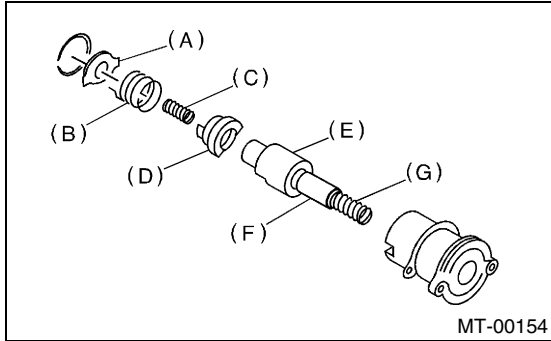

- (A) Reverse check plate
- (B) Reverse check spring
- (C) Return spring (5th-Rev)
- (D) Reverse check cam
- (E) Reverse accent shaft
- (F) Return spring cap
- (G) Return spring (1st-2nd)

3) Remove the O-ring.

NOTE:

- Reverse check sleeve assembly uses an O-ring which should not be scratched.
- Be careful not to break the adjustment shim placed between reverse check sleeve assembly and case.

D: ASSEMBLY

1) Install the return spring (1st-2nd), return spring cap, reverse accent shaft, check cam, return spring and check spring onto reverse check sleeve.

NOTE:

Be sure the bent section of reverse check spring is positioned in the groove in check cam.

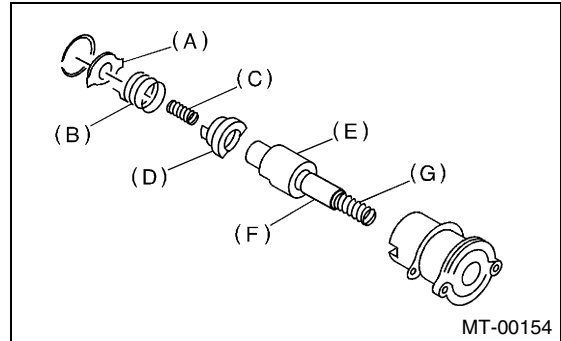

- (A) Reverse check spring
- (B) Reverse check cam
- (C) Return spring (5th-Rev)
- (D) Reverse accent shaft
- (E) Return spring cap
- (F) Return spring (1st-2nd)
- (G) Reverse check sleeve

2) Hook the bent section of reverse check spring over reverse check plate.

3) Rotate the cam so that the protrusion of reverse check cam is at the opening in plate.

4) With the cam held in that position, install the plate onto reverse check sleeve and hold with snap ring.

5) Position a new O-ring in groove in sleeve.

REVERSE CHECK SLEEVE

MANUAL TRANSMISSION AND DIFFERENTIAL

E: INSPECTION

- Make sure the cutout section of reverse accent shaft is aligned with the opening in reverse check sleeve.
- Spin the cam by hand for smooth rotation.
- Move the cam and shaft all the way toward plate and release.

If the cam does not return properly, replace the reverse check spring; if shaft does not, check for scratches on the inner surface of sleeve. If sleeve is in good order, replace the spring.

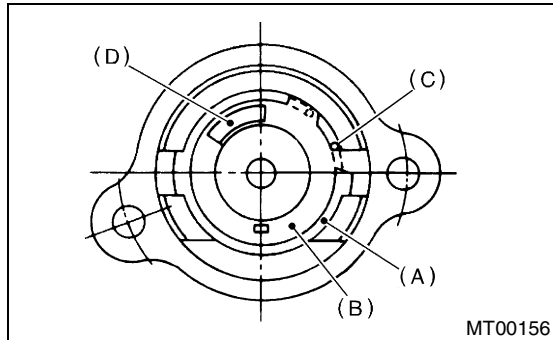

- (A) Snap ring
- (B) Reverse check plate
- (C) Check spring
- (D) Check cam

- Select a suitable reverse accent shaft and reverse check plate. <Ref. to MT-61, ADJUSTMENT, Reverse Check Sleeve.>

F: ADJUSTMENT

1. NEUTRAL POSITION ADJUSTMENT

- 1) Shift the gear into 3rd gear position.
- 2) Shifter arm turns lightly toward the 1st/2nd gear side but heavily toward the reverse gear side because of the function of return spring, until arm contacts the stopper.
- 3) Make adjustment so that the heavy stroke (reverse side) is a little more than the light stroke (1st/2nd side).
- 4) To adjust, remove the bolts holding reverse check sleeve assembly to the case, move the sleeve assembly outward, and place adjustment shim (0 to 1 ea.) between sleeve assembly and case to adjust the clearance.
- 5) Be careful not to break the O-ring when placing shim(s).

NOTE:

- When the shim is removed, the neutral position will move closer to reverse; when shim is added, the neutral position will move closer to 1st gear.
- If the shims alone cannot adjust clearance, replace the reverse accent shaft and re-adjust.

Adjustment shim	
Part No.	Thickness mm (in)
32190AA000	0.15 (0.0059)
32190AA010	0.30 (0.0118)

Reverse accent shaft		
Part No.	Mark	Remarks
32188AA090	3	Neutral position is closer to 1st gear.
32188AA100	0	Standard
32188AA110	1	Neutral position is closer to reverse gear.

REVERSE CHECK SLEEVE

MANUAL TRANSMISSION AND DIFFERENTIAL

2. REVERSE CHECK PLATE ADJUSTMENT

- 1) Shift the shifter arm to "5th" and then to reverse to see if reverse check mechanism operates properly.
- 2) Also check to see if the arm returns to neutral when released from reverse position. If the arm does not return properly, replace the reverse check plate.

Reverse check plate			
Part No.	(A): No.	Angle θ	Remarks
32189AA000	0	28°	Arm stops closer to 5th gear.
32189AA010	1	31°	Arm stops closer to 5th gear.
32189AA020	2	34°	Arm stops in the center.
32189AA030	3	37°	Arm stops closer to reverse gear.
32189AA040	4	40°	Arm stops closer to reverse gear.

