

# Diagnostics for A/C System Malfunction

HVAC SYSTEM (AUTO A/C) (DIAGNOSTICS)

## 6. Diagnostics for A/C System Malfunction

### A: A/C OR SELF-DIAGNOSIS SYSTEMS DO NOT OPERATE

#### TROUBLE SYMPTOM:

- Set temperature is not indicated on the display, switch LEDs are faulty or switches do not operate.
- Self-diagnosis system does not operate.

#### WIRING DIAGRAM:

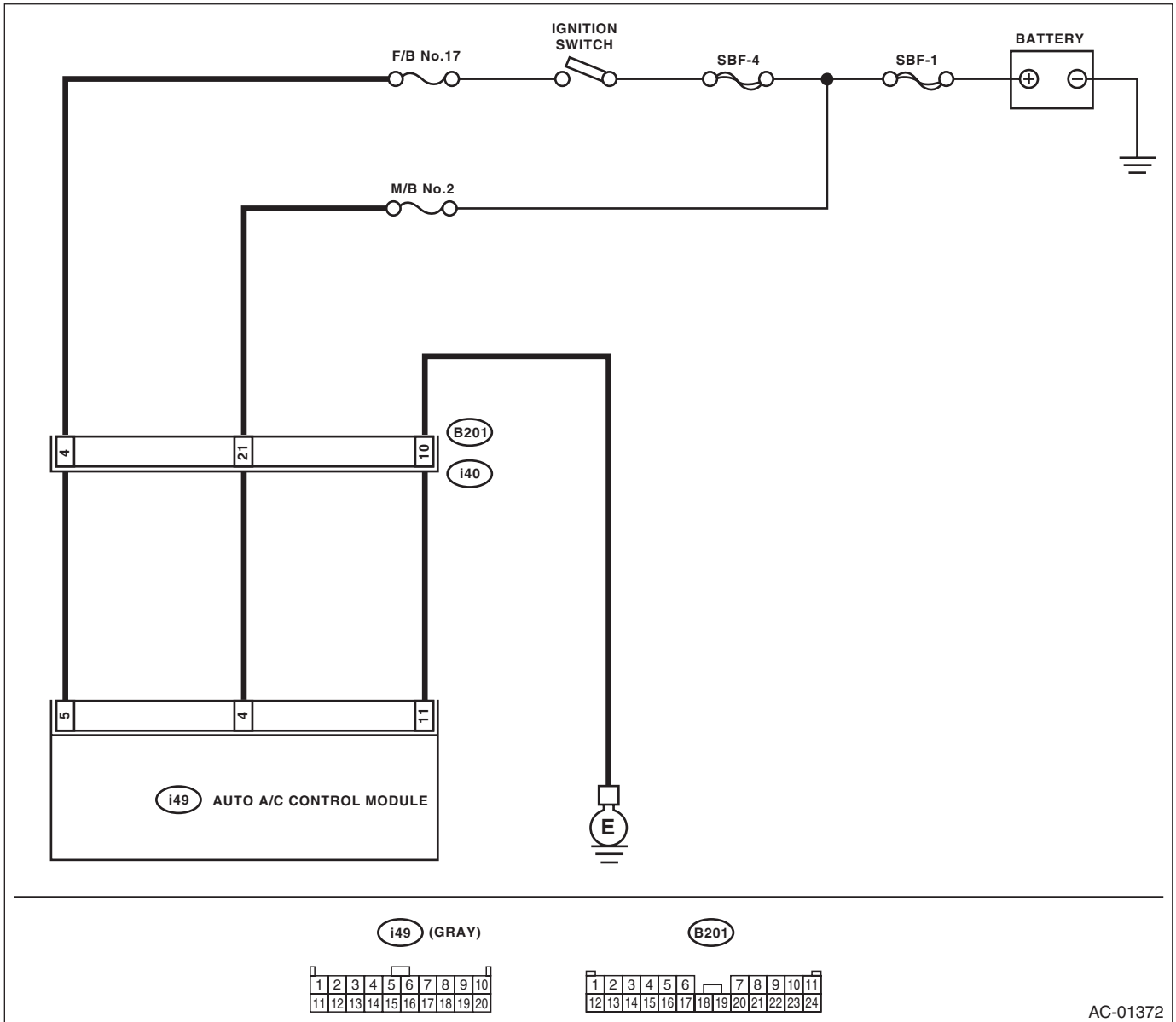

AC-01372

# Diagnostics for A/C System Malfunction

HVAC SYSTEM (AUTO A/C) (DIAGNOSTICS)

Step	Check	Yes	No	
1	<b>CHECK FUSE.</b> 1) Turn the ignition switch to OFF. 2) Remove the fuse No. 2 from main fuse box. 3) Check the condition of fuse.	Is the fuse blown out?	Replace the fuse.	Go to step 2.
2	<b>CHECK FUSE.</b> 1) Turn the ignition switch to OFF. 2) Remove the fuse No. 17 from fuse & relay box. 3) Check the condition of fuse.	Is the fuse blown out?	Replace the fuse.	Go to step 3.
3	<b>CHECK AUTO A/C CONTROL MODULE POWER CIRCUIT.</b> 1) Pull out the auto A/C control module connector. 2) Measure the voltage between auto A/C control module connector terminal and chassis ground after turning the ignition switch OFF. <b>Connector &amp; terminal</b> <b>(i49) No. 4 (+) — Chassis ground (-):</b>	Is the voltage 10 V or more?	Go to step 4.	Repair the short circuit in harness for power supply line.
4	<b>CHECK AUTO A/C CONTROL MODULE POWER CIRCUIT.</b> Measure the voltage between auto A/C control module connector terminal and chassis ground after turning the ignition switch to the ON position. <b>Connector &amp; terminal</b> <b>(i49) No. 5 (+) — Chassis ground (-):</b>	Is the voltage 10 V or more?	Go to step 5.	Repair the short circuit in harness for power supply line.
5	<b>CHECK AUTO A/C CONTROL MODULE GROUND CIRCUIT.</b> Measure the resistance of harness between auto A/C control module and chassis ground after turning the ignition switch to the ON position. <b>Connector &amp; terminal</b> <b>(i49) No. 11 — Chassis ground:</b>	Is the resistance less than 1 $\Omega$ ?	Go to step 6.	Repair the short circuit in harness for ground line.
6	<b>CHECK POOR CONTACT.</b> Check poor contact of auto A/C control module connector.	Is there poor contact in the connector?	Repair the connector.	Replace the auto A/C control module.

# Diagnostics for A/C System Malfunction

HVAC SYSTEM (AUTO A/C) (DIAGNOSTICS)

## B: BLOWER FAN DOES NOT ROTATE

### TROUBLE SYMPTOM:

- Blower motor does not rotate.
- Blower motor does not change speeds.

### WIRING DIAGRAM:

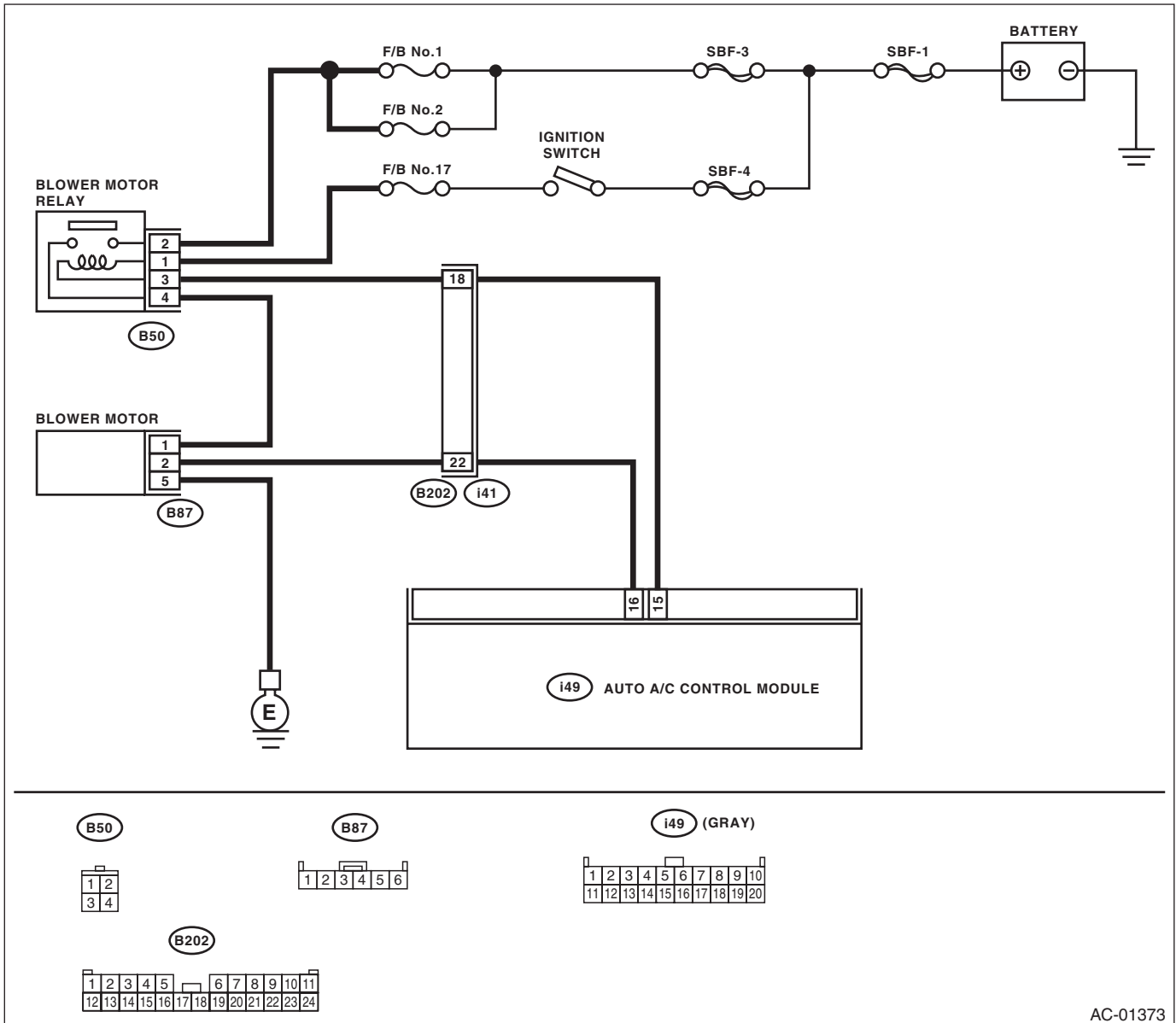

AC-01373

# Diagnostics for A/C System Malfunction

HVAC SYSTEM (AUTO A/C) (DIAGNOSTICS)

Step	Check	Yes	No
<b>1</b> <b>CHECK FUSE.</b> 1) Remove fuse No. 1, 2 and 17 from fuse & relay box. 2) Check the condition of fuse.	Is any of the fuses blown out?	Replace the fuse.	Go to step 2.
<b>2</b> <b>CHECK POWER SUPPLY FOR BLOWER MOTOR.</b> 1) Turn the ignition switch to ON. 2) Turn the fan speed control dial to the right. 3) Measure the voltage between blower motor and chassis ground. <b>Connector &amp; terminal</b> <b>(B87) No. 1 (+) — Chassis ground (-):</b>	Is the voltage 8 V or more (at normal temperature)?	Go to step 3.	Repair the open circuit of blower motor power supply line harness.
<b>3</b> <b>CHECK BLOWER MOTOR RELAY.</b> 1) Turn the ignition switch to OFF. 2) Remove the blower motor relay. 3) Connect the battery positive (+) terminal to terminal No. 1 of blower motor connector, and negative (-) terminal to terminal No. 3. 4) Measure the resistance between terminals No. 2 and 4. <b>Terminals</b> <b>No. 2 — No. 4:</b>	Is the resistance less than 1 $\Omega$ ?	Go to step 4.	Replace the blower motor relay.
<b>4</b> <b>CHECK BLOWER MOTOR.</b> 1) Disconnect the connector from the blower motor. 2) Connect the battery positive (+) terminal to terminal No. 1 of the blower motor connector, and negative (-) terminal to terminals No. 2 and 5. 3) Make sure the blower motor runs.	Does the blower motor run?	Go to step 5.	Replace the blower motor.
<b>5</b> <b>CHECK POOR CONTACT.</b> Check poor contact of auto A/C control module connector.	Is there poor contact in the connector?	Repair the connector.	Replace the auto A/C control module.

# Diagnostics for A/C System Malfunction

HVAC SYSTEM (AUTO A/C) (DIAGNOSTICS)

## C: COMPARTMENT TEMPERATURE DOES NOT CHANGE, OR A/C SYSTEM DOES NOT RESPOND PROMPTLY

### TROUBLE SYMPTOM:

- Compartment temperature does not change.
- A/C system does not respond quickly.

### WIRING DIAGRAM:

- Non-turbo model

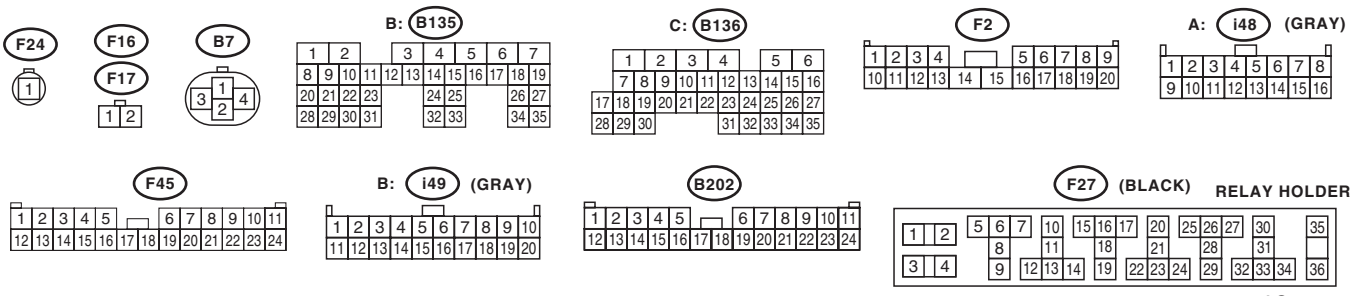
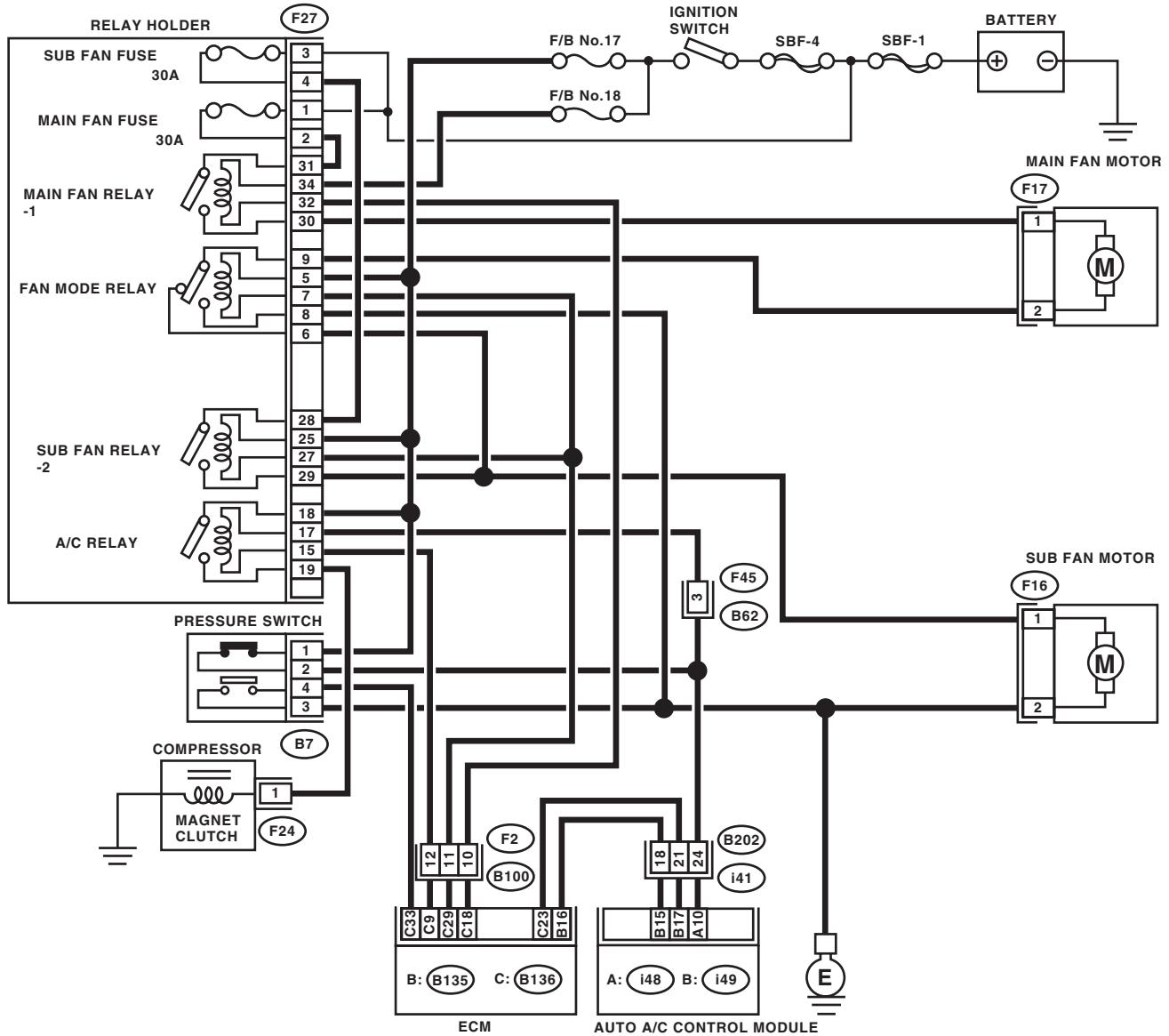

AC-01369

# Diagnostics for A/C System Malfunction

HVAC SYSTEM (AUTO A/C) (DIAGNOSTICS)

- Turbo model

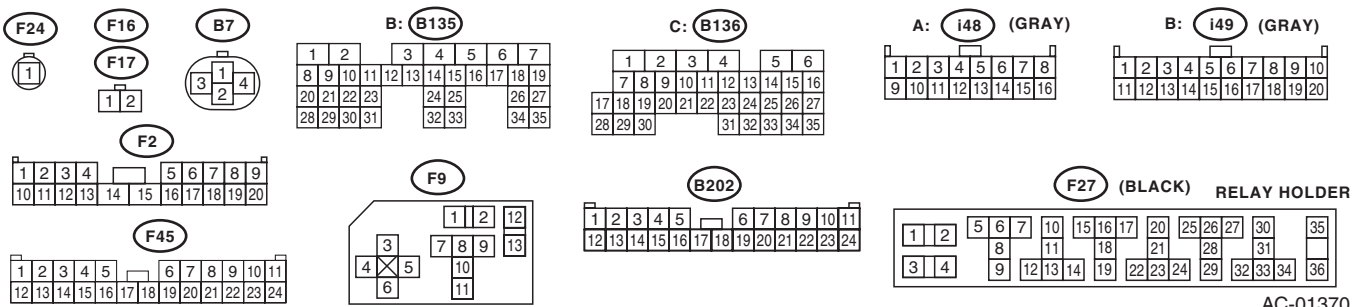
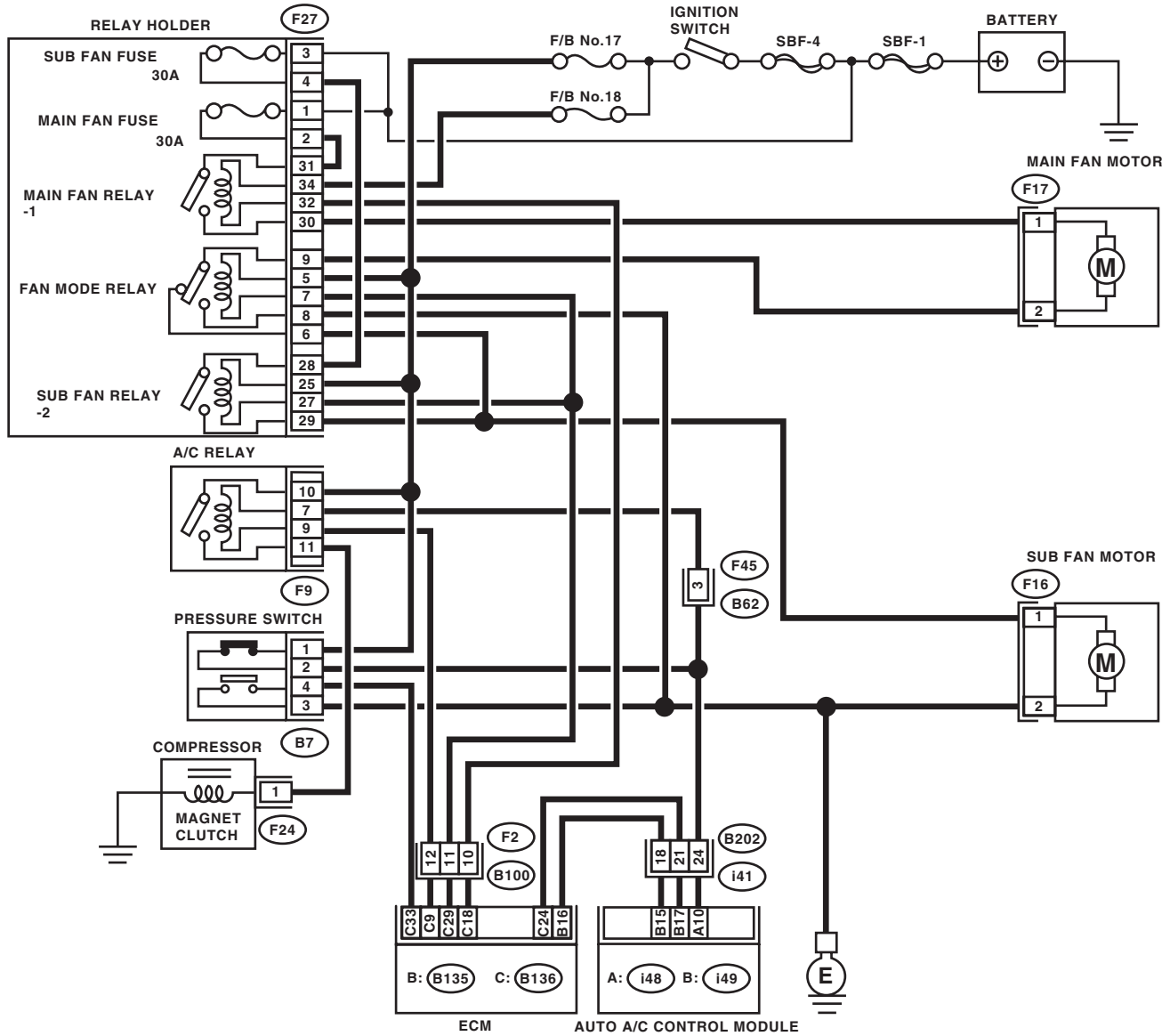

AC-01370

# Diagnostics for A/C System Malfunction

## HVAC SYSTEM (AUTO A/C) (DIAGNOSTICS)

Step	Check	Yes	No
<b>1 CHECK FUSE.</b> 1) Turn the ignition switch to OFF. 2) Remove the main fan fuse and sub fan fuse of the main fuse box. 3) Check the condition of fuse.	Is the fuse blown out?	Replace the fuse.	Go to step 2.
<b>2 CHECK POWER SUPPLY FOR PRESSURE SWITCH.</b> 1) Disconnect the connector from the pressure switch. 2) Turn the ignition switch to ON. 3) Measure the voltage between pressure switch harness connector and chassis ground. <b>Connector &amp; terminal</b> <b>(B7) No. 1 (+) — Chassis ground (-):</b>	Is the voltage 10 V or more?	Go to step 3.	Repair the open circuit in harness of pressure switch power supply circuit.
<b>3 CHECK HARNESS BETWEEN PRESSURE SWITCH AND A/C RELAY.</b> 1) Turn the ignition switch to OFF. 2) Remove the A/C relay of the fuse box. 3) Measure the resistance of the A/C relay and pressure switch connector. <b>Connector &amp; terminal</b> <b>Non-turbo model</b> <b>(F27) No. 17 — (B7) No. 2:</b> <b>Turbo model</b> <b>(F9) No. 7 — (B7) No. 2:</b>	Is the resistance less than 1 $\Omega$ ?	Go to step 4.	Repair the open circuit of the harness between the A/C relay and pressure switch.
<b>4 CHECK PRESSURE SWITCH.</b> Measure the resistance between the pressure switch terminals. <b>Terminals</b> <b>No. 1 — No. 2:</b>	Is the resistance less than 1 $\Omega$ ?	Go to step 5.	Replace the pressure switch.
<b>5 CHECK A/C CUT SIGNAL CIRCUIT.</b> 1) Disconnect the connector from the auto A/C control module. 2) Measure the resistance between the auto A/C control module and the pressure switch connector. <b>Connector &amp; terminal</b> <b>(i48) No. 10 — (B7) No. 2:</b>	Is the resistance less than 1 $\Omega$ ?	Go to step 6.	Repair the open circuit of the harness between auto A/C control module and pressure switch.
<b>6 CHECK A/C ON SIGNAL CIRCUIT.</b> 1) Disconnect the connectors from ECM. 2) Measure the resistance between the ECM and the auto A/C control module connector. <b>Connector &amp; terminal</b> <b>Non-turbo model</b> <b>(B136) No. 23 — (i49) No. 17:</b> <b>Turbo model</b> <b>(B136) No. 24 — (i49) No. 17:</b>	Is the resistance less than 1 $\Omega$ ?	Go to step 7.	Repair the open circuit of the harness between auto A/C control module and ECM.
<b>7 CHECK A/C RELAY.</b> 1) Remove the A/C relay of the fuse box. 2) Check the A/C relay. <Ref. to AC-35, INSPECTION, Relay and Fuse.>	Does the relay operate normally?	Go to step 8.	Replace the A/C relay.

# Diagnostics for A/C System Malfunction

HVAC SYSTEM (AUTO A/C) (DIAGNOSTICS)

Step	Check	Yes	No
<b>8 CHECK POWER SUPPLY TO MAGNET CLUTCH OF A/C COMPRESSOR.</b> 1) Turn the ignition switch to OFF, and connect the A/C relay and all disconnected connectors. 2) Start the engine and turn the A/C switch ON. 3) Turn the temperature control dial at maximum cool position. 4) Measure the voltage between magnet clutch connector and chassis ground. <b>Connector &amp; terminal</b> <b>(F24) No. 1 (+) — Chassis ground (-):</b>	Is the voltage 10.5 V or more (at normal temperature)?	Go to step 9.	Repair the open circuit in harness of the A/C compressor power circuit.
<b>9 CHECK MAIN FAN MOTOR OPERATION.</b> 1) Start the engine. 2) Turn on the A/C switch. 3) Check the operation of the main fan motor.	Does the main fan motor operate normally?	Go to step 14.	Go to step 10.
<b>10 CHECK POWER SUPPLY TO MAIN FAN MOTOR.</b> <b>CAUTION:</b> <b>Be careful not to overheat the engine during repair.</b> 1) Turn the ignition switch to OFF. 2) Disconnect the connector from the main fan motor. 3) Start the engine, and warm it up until engine coolant temperature increases over 100°C (212°F). 4) Stop the engine and turn the ignition switch to ON. 5) Measure the voltage between main fan motor connector and chassis ground. <b>Connector &amp; terminal</b> <b>(F17) No. 1 (+) — Chassis ground (-):</b>	Is the voltage 10 V or more?	Go to step 11.	Repair the open circuit in harness of main fan motor power supply circuit.
<b>11 CHECK MAIN FAN MOTOR GROUND CIRCUIT.</b> 1) Turn the ignition switch to OFF. 2) Measure the resistance between main fan motor connector and chassis ground. <b>Connector &amp; terminal</b> <b>(F17) No. 2 — Chassis ground:</b>	Is the resistance less than 1 Ω?	Go to step 12.	Repair the open circuit in harness of main fan motor ground circuit.
<b>12 CHECK MAIN FAN MOTOR.</b> Connect the positive terminal (+) of the battery to No. 1 terminal of the main fan motor connector, and the negative (-) terminal to No. 2 terminal. Check that the main fan motor is running.	Is the main fan motor rotating?	Go to step 13.	Replace the main fan motor with a new one.
<b>13 CHECK POOR CONTACT OF THE MAIN FAN MOTOR CONNECTOR.</b> Check poor contact of main fan motor connector.	Is there poor contact in the connector?	Go to step 14.	Repair the poor contact of main fan motor connector.
<b>14 CHECK SUB FAN MOTOR OPERATION.</b> 1) Start the engine and turn the A/C switch ON. 2) Check the operation of the sub fan motor.	Does the sub fan motor operate normally?	Go to step 19.	Go to step 15.



## Diagnostics for A/C System Malfunction

### HVAC SYSTEM (AUTO A/C) (DIAGNOSTICS)

Step	Check	Yes	No
<b>15 CHECK POWER SUPPLY TO SUB FAN MOTOR.</b> <b>CAUTION:</b> <b>Be careful not to overheat the engine during repair.</b> 1) Turn the ignition switch to OFF. 2) Disconnect the connector from the sub fan motor. 3) Start the engine, and warm it up until engine coolant temperature increases over 100°C (212°F). 4) Stop the engine and turn the ignition switch to ON. 5) Measure the voltage between sub fan motor connector and chassis ground. <b>Connector &amp; terminal</b> <b>(F16) No. 1 (+) — Chassis ground (-):</b>	Is the voltage 10 V or more?	Go to step 16.	Repair the open circuit in the harness of the sub fan motor power supply circuit.
<b>16 CHECK SUB FAN MOTOR GROUND CIRCUIT.</b> 1) Turn the ignition switch to OFF. 2) Measure the resistance between the sub fan motor connector and chassis ground. <b>Connector &amp; terminal</b> <b>(F16) No. 2 — Chassis ground:</b>	Is the resistance less than 1 Ω?	Go to step 17.	Repair the open circuit in the harness of sub fan motor ground circuit.
<b>17 CHECK SUB FAN MOTOR.</b> Connect the positive terminal (+) of the battery to No. 1 terminal of the sub fan motor connector, and the negative (-) terminal to No. 2 terminal. Check that the sub fan motor is running.	Does the sub fan motor rotate?	Go to step 18.	Replace the sub fan motor with a new one.
<b>18 CHECK POOR CONTACT OF THE SUB FAN MOTOR CONNECTOR.</b> Check for poor contact of sub fan motor connector.	Is there poor contact in the connector?	Repair the poor contact of sub fan motor connector.	Go to step 19.
<b>19 CHECK FOR POOR CONTACT OF THE AUTO A/C CONTROL MODULE CONNECTOR.</b> Check poor contact of auto A/C control module connector.	Is there poor contact in the connector?	Repair the connector.	Replace the auto A/C control module.