

# Diagnostic Procedure for Sensors

HVAC SYSTEM (AUTO A/C) (DIAGNOSTICS)

## 8. Diagnostic Procedure for Sensors

### A: AMBIENT SENSOR

#### TROUBLE SYMPTOM:

- Fan speed is not switched when the fan speed control dial is in AUTO position.
- Failure related to the ambient sensor is indicated in self-diagnosis.

#### WIRING DIAGRAM:

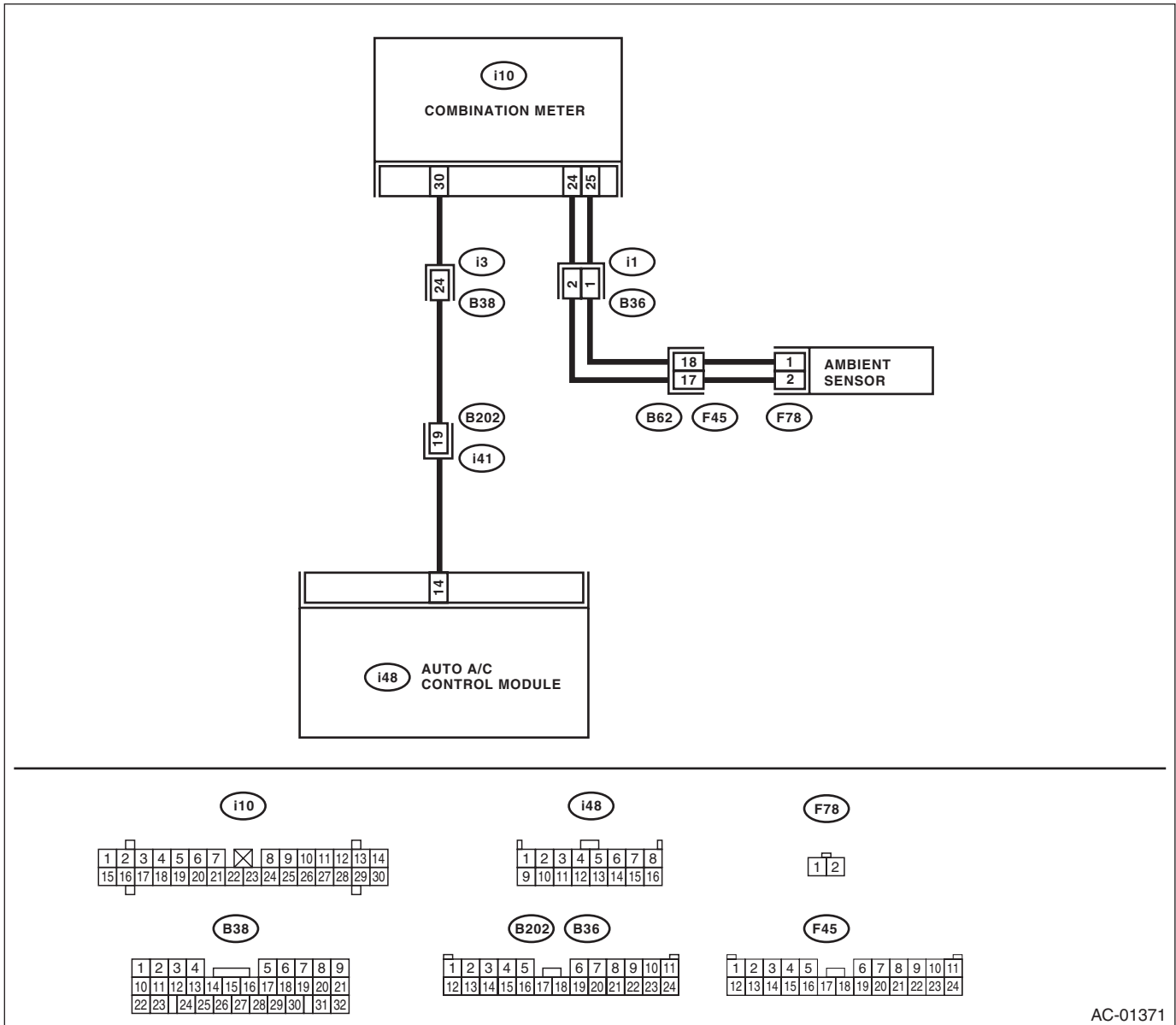

AC-01371

# Diagnostic Procedure for Sensors

HVAC SYSTEM (AUTO A/C) (DIAGNOSTICS)

Step	Check	Yes	No
<b>1 CHECK HARNESS BETWEEN AUTO A/C CONTROL MODULE AND COMBINATION METER.</b> 1) Turn the ignition switch to OFF. 2) Disconnect the connector from auto A/C control module and the combination meter. 3) Measure the resistance of harness between the auto A/C control module and combination meter. <b>Connector &amp; terminal</b> <b>(i10) No. 30 — (i48) No. 14:</b>	Is the resistance less than 1 Ω?	Go to step 2.	Repair the open circuit of the harness between auto A/C control module and combination meter.
<b>2 CHECK AMBIENT SENSOR CIRCUIT.</b> Check the ambient sensor circuit. <Ref. to IDI-9, CHECK OUTSIDE TEMPERATURE INDICATOR, INSPECTION, Combination Meter System.>	Is the ambient sensor circuit normal?	Go to step 3.	Repair the ambient sensor circuit.
<b>3 CHECK POOR CONTACT.</b> Check poor contact of auto A/C control module connector.	Is there poor contact in the connector?	Repair the connector.	Replace the auto A/C control module.

# Diagnostic Procedure for Sensors

HVAC SYSTEM (AUTO A/C) (DIAGNOSTICS)

## B: IN-VEHICLE SENSOR

### TROUBLE SYMPTOM:

- Blower fan speed, outlet port and inlet port do not change after turning the AUTO switch ON
- Failure related to the in-vehicle sensor is indicated in self-diagnosis.

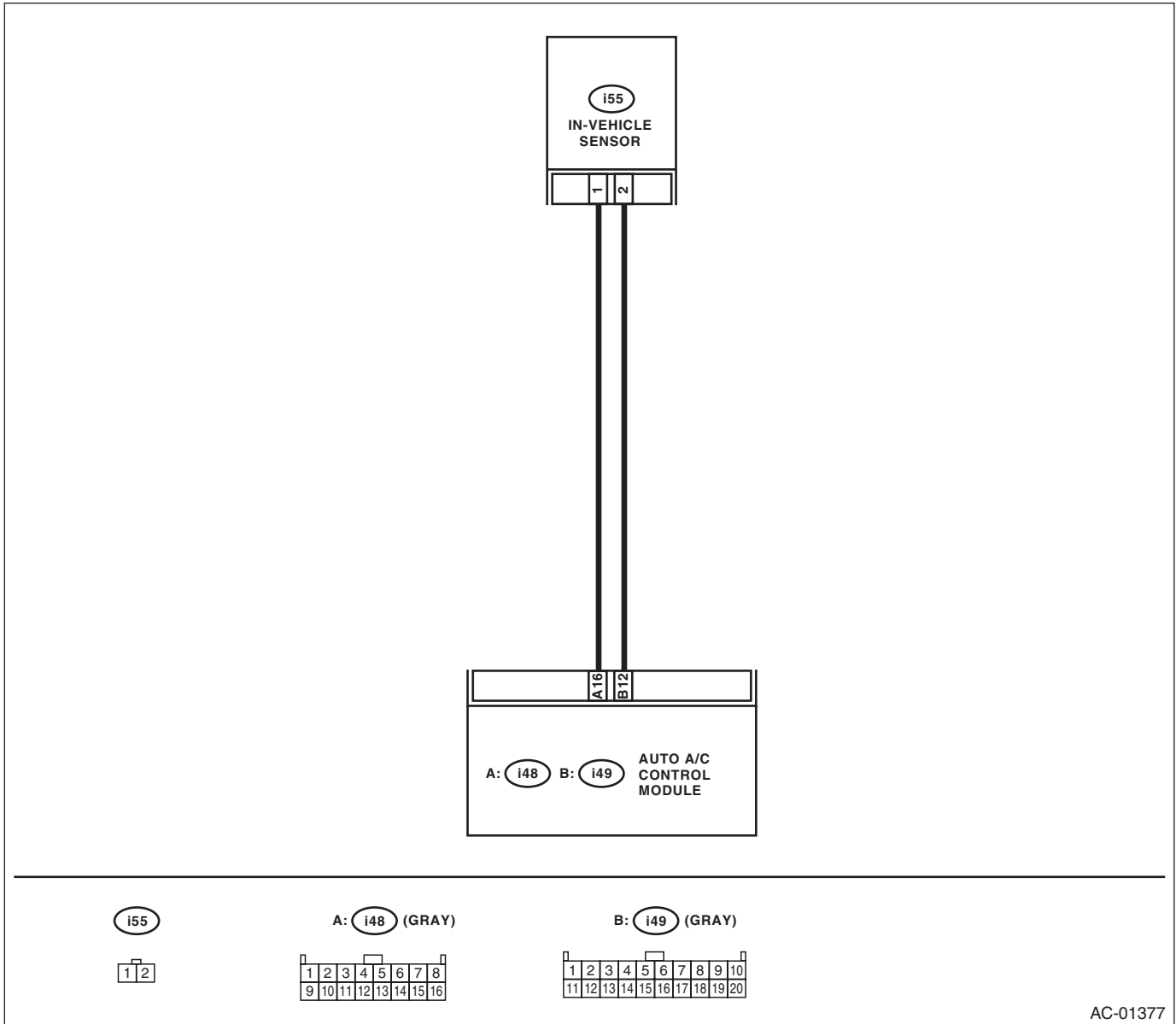

AC-01377

# Diagnostic Procedure for Sensors

HVAC SYSTEM (AUTO A/C) (DIAGNOSTICS)

Step	Check	Yes	No
<b>1 CHECK IN-VEHICLE SENSOR.</b> 1) Turn the ignition switch to OFF. 2) Remove the driver side lower cover. 3) Disconnect the connector from in-vehicle sensor. 4) Measure the resistance between connector terminals of in-vehicle sensor. <b>Terminals</b> <b>No. 1 — No. 2:</b>	Is the resistance approximately 2.7 k $\Omega$ at 20°C (68°F)?	Go to step 2.	Replace the in-vehicle sensor.
<b>2 CHECK INPUT SIGNAL FOR IN-VEHICLE SENSOR.</b> 1) Turn the ignition switch to ON. 2) Measure the voltage between in-vehicle sensor harness connector terminal and chassis ground. <b>Connector &amp; terminal</b> <b>(i55) No. 2 (+) — Chassis ground (-):</b>	Is the voltage approx. 5 V?	Go to step 5.	Go to step 3.
<b>3 CHECK AUTO A/C CONTROL MODULE OUTPUT SIGNAL.</b> 1) Turn the ignition switch to OFF. 2) Pull out the auto A/C control module. 3) Turn the ignition switch to ON. 4) Measure the voltage between connector terminals of auto A/C control module. <b>Connector &amp; terminal</b> <b>(i49) No. 12 (+) — (i48) No. 16 (-):</b>	Is the voltage approx. 5 V?	Go to step 4.	Go to step 6.
<b>4 CHECK HARNESS BETWEEN AUTO A/C CONTROL MODULE AND IN-VEHICLE SENSOR.</b> 1) Turn the ignition switch to OFF. 2) Disconnect the connector from the auto A/C control module. 3) Measure the resistance of harness between auto A/C control module and in-vehicle sensor. <b>Connector &amp; terminal</b> <b>(i55) No. 2 — (i49) No. 12:</b>	Is the resistance less than 1 $\Omega$ ?	Go to step 5.	Repair the open circuit of the harness between auto A/C control module and in-vehicle sensor.
<b>5 CHECK HARNESS BETWEEN AUTO A/C CONTROL MODULE AND IN-VEHICLE SENSOR.</b> Measure the resistance of harness between auto A/C control module and in-vehicle sensor. <b>Connector &amp; terminal</b> <b>(i55) No. 1 — (i48) No. 16:</b>	Is the resistance less than 1 $\Omega$ ?	Go to step 6.	Repair the open circuit of the harness between auto A/C control module and in-vehicle sensor.
<b>6 CHECK POOR CONTACT.</b> Check poor contact of auto A/C control module connector.	Is there poor contact in the connector?	Repair the connector.	Replace the auto A/C control module.

# Diagnostic Procedure for Sensors

HVAC SYSTEM (AUTO A/C) (DIAGNOSTICS)

## C: EVAPORATOR SENSOR

WIRING DIAGRAM:

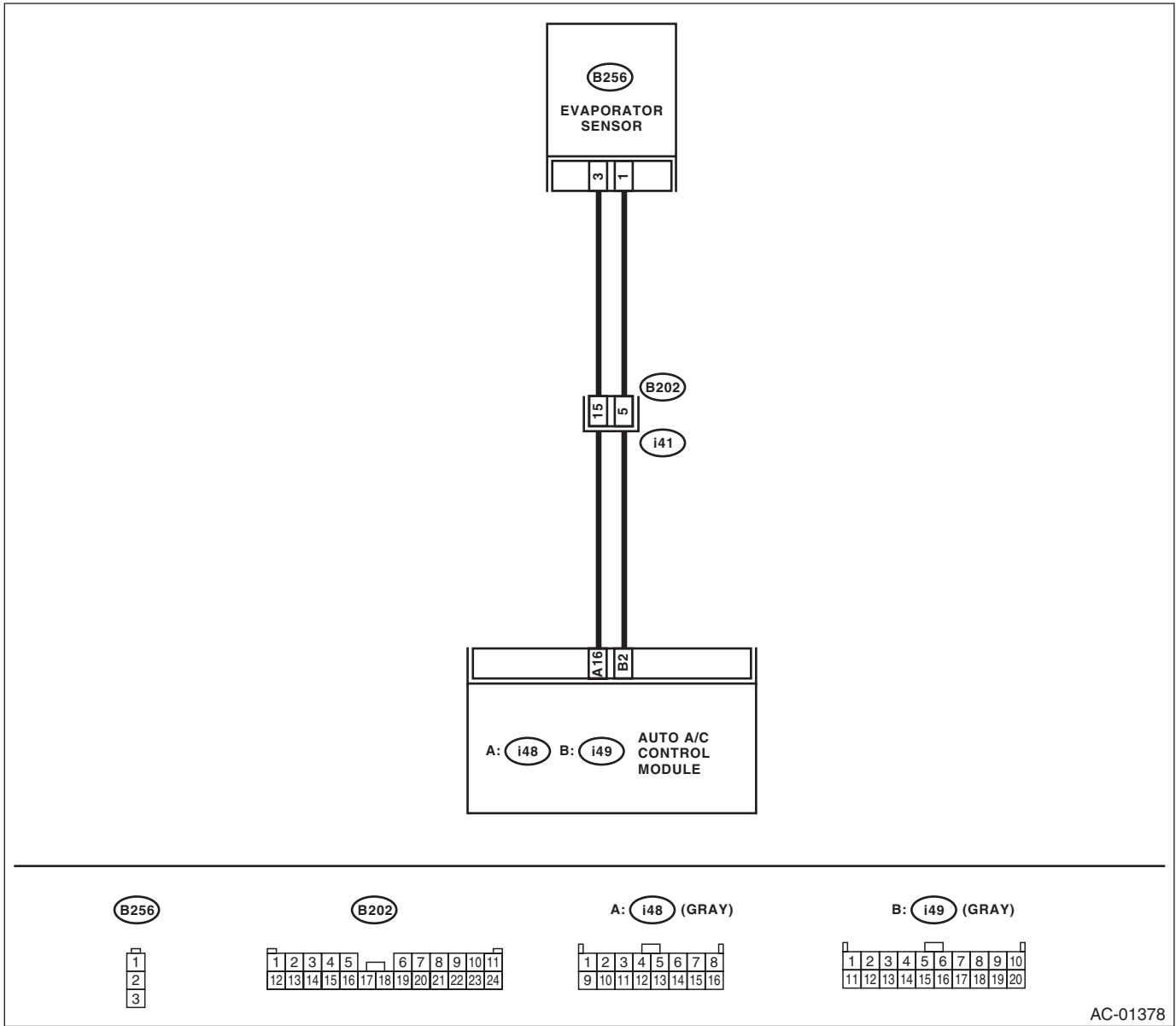

AC-01378

# Diagnostic Procedure for Sensors

HVAC SYSTEM (AUTO A/C) (DIAGNOSTICS)

Step	Check	Yes	No
<b>1 CHECK EVAPORATOR SENSOR.</b> 1) Turn the ignition switch to OFF. 2) Remove the glove box. 3) Disconnect the connector from evaporator sensor. 4) Measure the resistance between connector terminals of the evaporator sensor. <b>Terminals</b> <b>No. 1 — No. 3:</b>	Is the resistance approximately 2.7 k $\Omega$ at 20°C (68°F)?	Go to step 2.	Replace the evaporator sensor.
<b>2 CHECK INPUT SIGNAL FOR EVAPORATOR SENSOR.</b> 1) Turn the ignition switch to ON. 2) Measure the voltage between evaporator sensor harness connector terminal and chassis ground. <b>Connector &amp; terminal</b> <b>(B256) No. 1 (+) — Chassis ground (-):</b>	Is the voltage approx. 5 V?	Go to step 5.	Go to step 3.
<b>3 CHECK AUTO A/C CONTROL MODULE OUTPUT SIGNAL.</b> 1) Turn the ignition switch to OFF. 2) Pull out the auto A/C control module. 3) Turn the ignition switch to ON. 4) Measure the voltage between connector terminals of auto A/C control module. <b>Connector &amp; terminal</b> <b>(i49) No. 2 (+) — (i48) No. 16 (-):</b>	Is the voltage approx. 5 V?	Go to step 4.	Go to step 6.
<b>4 CHECK HARNESS CONNECTOR BETWEEN AUTO A/C CONTROL MODULE AND EVAPORATOR SENSOR.</b> 1) Turn the ignition switch to OFF. 2) Disconnect the connector from the auto A/C control module. 3) Measure the resistance of harness between auto A/C control module and evaporator sensor. <b>Connector &amp; terminal</b> <b>(B256) No. 1 — (i49) No. 2:</b>	Is the resistance less than 1 $\Omega$ ?	Go to step 5.	Repair the open circuit of harness between auto A/C control module and evaporator sensor.
<b>5 CHECK HARNESS CONNECTOR BETWEEN AUTO A/C CONTROL MODULE AND EVAPORATOR SENSOR.</b> Measure the resistance of harness between auto A/C control module and evaporator sensor. <b>Connector &amp; terminal</b> <b>(B256) No. 3 — (i48) No. 16:</b>	Is the resistance less than 1 $\Omega$ ?	Go to step 6.	Repair the open circuit of harness between auto A/C control module and evaporator sensor.
<b>6 CHECK POOR CONTACT.</b> Check poor contact of auto A/C control module connector.	Is there poor contact in the connector?	Repair the connector.	Replace the auto A/C control module.

# Diagnostic Procedure for Sensors

HVAC SYSTEM (AUTO A/C) (DIAGNOSTICS)

## D: SUNLOAD SENSOR

### TROUBLE SYMPTOM:

- Sensor identifies that sunlight is at maximum. Then, A/C system is controlled to COOL side.
- Sensor identifies that sunlight is at minimum. Then, A/C system is controlled to HOT side.

### NOTE:

When the sunload sensor is checked indoors or in the shade, an open circuit might be indicated. Always check the sunload sensor at a location exposed to direct sunlight.

### WIRING DIAGRAM:

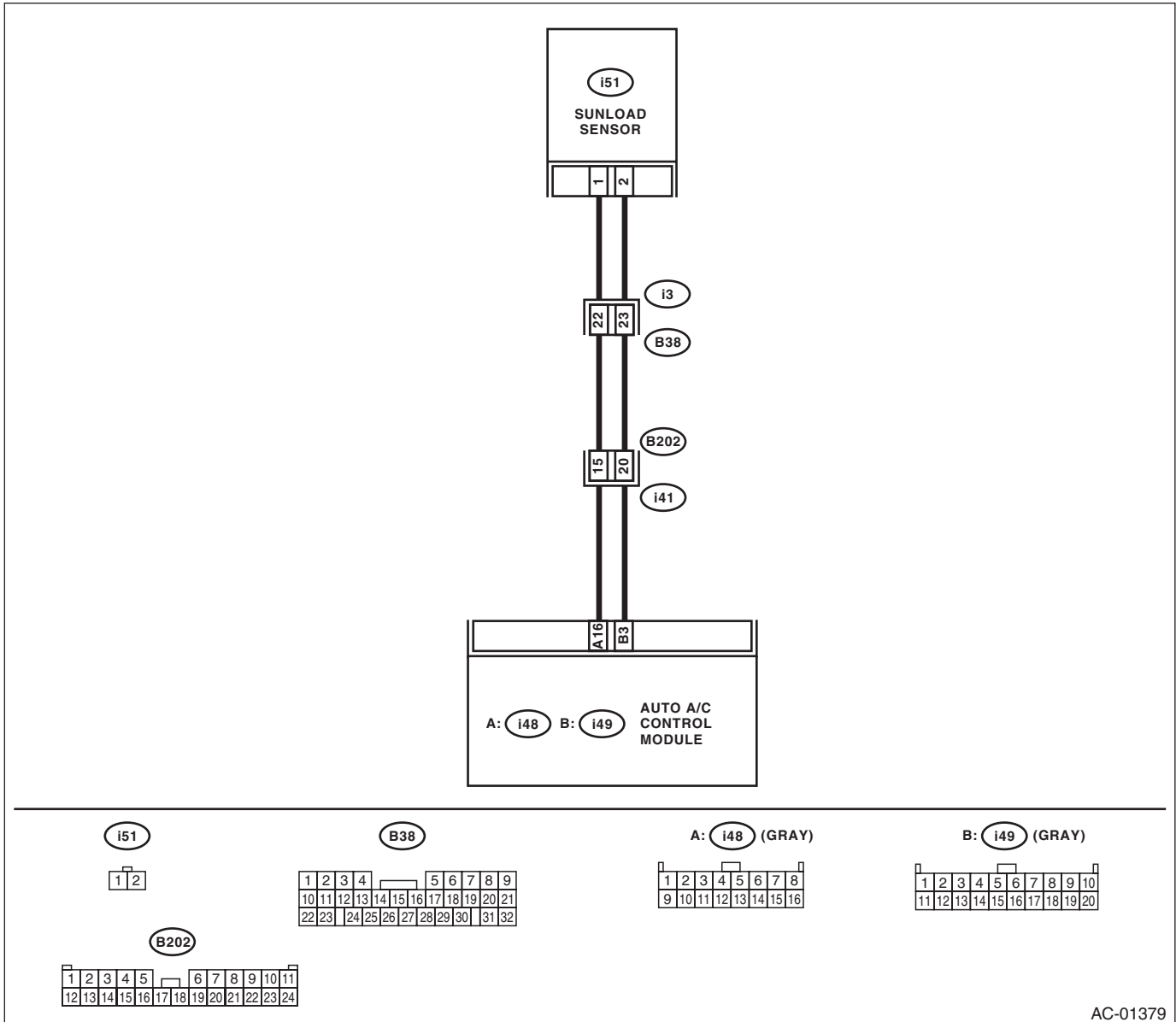

AC-01379

# Diagnostic Procedure for Sensors

HVAC SYSTEM (AUTO A/C) (DIAGNOSTICS)

Step	Check	Yes	No
<b>1 CHECK INPUT VOLTAGE TO SUNLOAD SENSOR.</b> 1) Turn the ignition switch to ON. 2) Measure the input voltage to sunload sensor. <i>Connector &amp; terminal</i> <i>(i51) No. 2 (+) — Chassis ground (-):</i>	Is the voltage approx. 5 V?	Go to step 3.	Go to step 2.
<b>2 CHECK HARNESS CONNECTOR BETWEEN AUTO A/C CONTROL MODULE AND SUNLOAD SENSOR.</b> 1) Turn the ignition switch to OFF. 2) Disconnect the connector from the auto A/C control module. 3) Measure the resistance of the harness between the auto A/C control module and sunload sensor. <i>Connector &amp; terminal</i> <i>(i51) No. 2 — (i49) No. 3:</i>	Is the resistance less than 1 $\Omega$ ?	Go to step 5.	Repair the harness between auto A/C control module and sunload sensor.
<b>3 CHECK HARNESS CONNECTOR BETWEEN AUTO A/C CONTROL MODULE AND SUNLOAD SENSOR.</b> Measure the resistance of the harness between the auto A/C control module and sunload sensor. <i>Connector &amp; terminal</i> <i>(i51) No. 1 — (i48) No. 16:</i>	Is the resistance less than 1 $\Omega$ ?	Go to step 4.	Repair the harness between auto A/C control module and sunload sensor.
<b>4 CHECK INPUT VOLTAGE FOR AUTO A/C CONTROL MODULE.</b> 1) Connect the auto A/C control module connector. 2) Turn the ignition switch to ON. 3) Measure the voltage between connector terminals of auto A/C control module. <i>Connector &amp; terminal</i> <i>(i49) No. 3 (+) — (i48) No. 16 (-):</i>	Is the voltage approx. 2.5 V?	Go to step 5.	Replace the sunload sensor.
<b>5 CHECK POOR CONTACT.</b> Check poor contact of auto A/C control module connector.	Is there poor contact of the connector?	Repair the connector.	Replace the auto A/C control module.