

Condenser

HVAC SYSTEM (HEATER, VENTILATOR AND A/C)

12. Condenser

A: REMOVAL

- 1) Using the refrigerant recovery system, discharge refrigerant. <Ref. to AC-19, PROCEDURE, Refrigerant Recovery Procedure.>
- 2) Disconnect the ground cable from the battery.
- 3) Disconnect the pressure hose and pipe from the condenser.

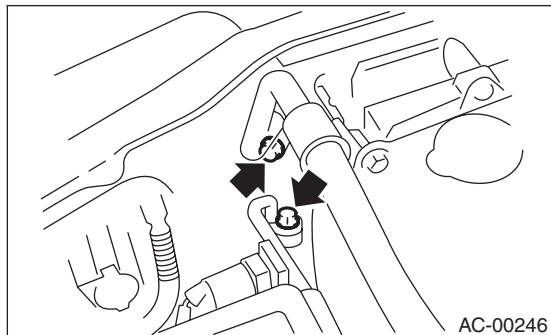

- 4) Remove the radiator bracket (A).

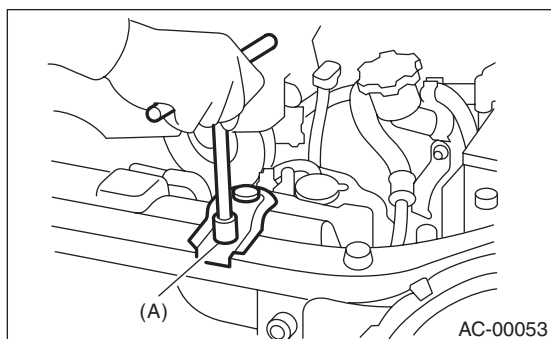

- 5) Remove two bolts. While lifting condenser, pull it out through space between the radiator and the radiator panel.

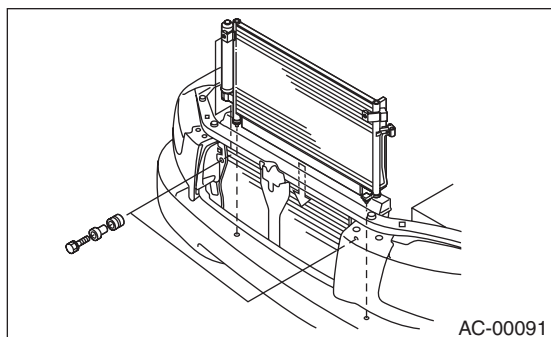

CAUTION:

Be careful not to damage the radiator fins and condenser fins. If a damaged fin is found, repair it using a thin screwdriver.

If the condenser is replaced, add appropriate amount of compressor oil to the compressor. <Ref. to AC-24, REPLACEMENT, Compressor Oil.>

B: INSTALLATION

- 1) Install in the reverse order of removal.

CAUTION:

Replace the O-rings on hoses or pipes with new parts, and then apply compressor oil. Confirm that lower guide of condenser fits into holes on radiator panel.

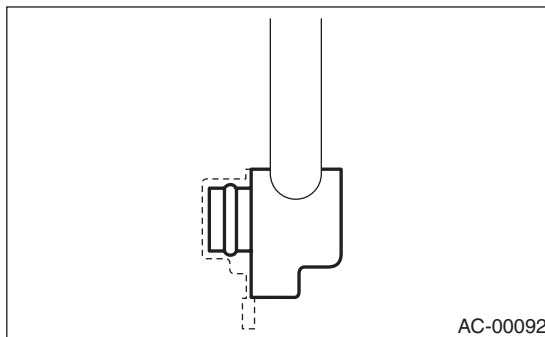

- 2) Charge refrigerant. <Ref. to AC-20, PROCEDURE, Refrigerant Charging Procedure.>

Tightening torque:

Refer to "COMPONENT" of "General Description". <Ref. to AC-11, AIR CONDITIONING UNIT, COMPONENT, General Description.> <Ref. to CO(H4SO)-7, RADIATOR AND ELECTRIC FAN, COMPONENT, General Description.>

C: INSPECTION

- 1) Confirm that no dust or insects are found on the condenser fins. Air-blow or flush fins with water as needed.
- 2) Confirm that no oil leakage from the condenser. If a failure is found, replace the condenser with a new part.