

Airbag Warning Light Failure

A: AIRBAG WARNING LIGHT REMAINS ON

DETECTING CONDITION:

- Airbag warning light failure
- Airbag control module to airbag warning light circuit is shorted or open.
- Grounding circuit is faulty.
- Airbag control module is faulty.
- Improper connection of (AB1) and (B31)
- Improper connection of (AB3) to airbag control module

CAUTION:

- Before diagnosing the airbag system, be sure to turn the ignition switch to OFF, disconnect the ground terminal from battery, and wait more than 20 seconds before starting to work.
- When inspecting the airbag main harness, disconnect the airbag module connectors of the driver's and passenger's seats for safety.

WIRING DIAGRAM:

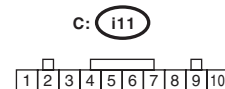
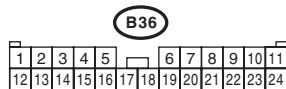
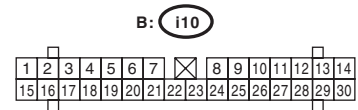
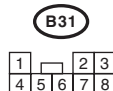
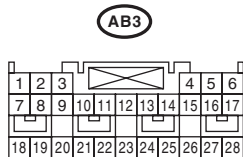
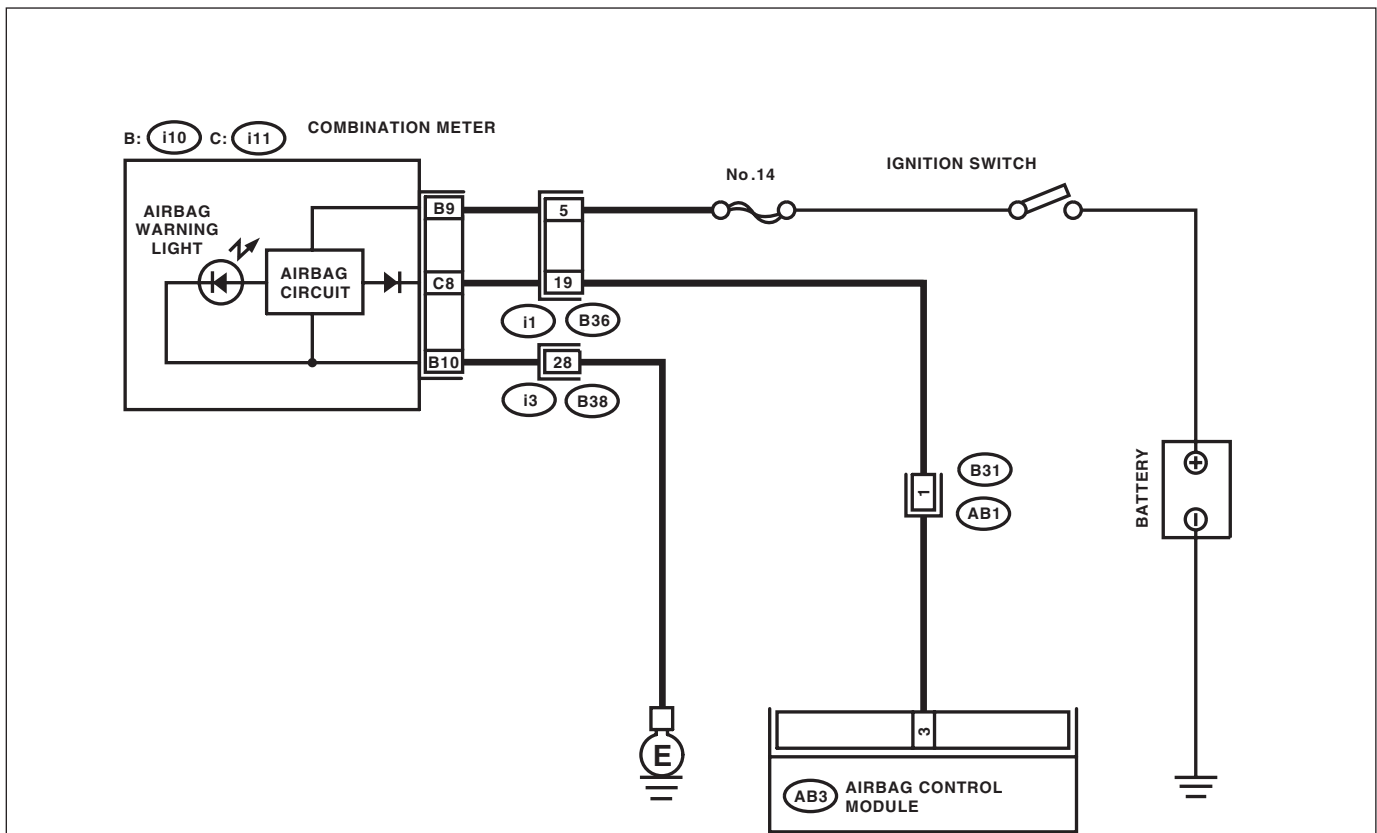

AB-01547

Airbag Warning Light Failure

AIRBAG SYSTEM (DIAGNOSTICS)

	Step	Check	Yes	No
1	READ DTC. Read the DTC. <Ref. to AB(diag)-29, READ DIAGNOSTIC TROUBLE CODE (DTC), OPERATION, Subaru Select Monitor.>	Is DTC displayed?	Perform the diagnosis according to DTC.	Go to step 2.
2	CHECK POOR CONTACT. 1) Turn ignition switch OFF, disconnect the battery ground cable, and wait more than 20 seconds. 2) Check that firm contact is secured between the airbag control module and the connector (AB3).	Is there poor contact in the connector (AB3)?	Replace the body harness along with airbag main harness or airbag control module, if it is not eliminated the poor contact of connectors. <Ref. to AB-18, Airbag Control Module.>	Go to step 3.
3	CHECK AIRBAG MAIN HARNESS. 1) Remove the instrument panel lower cover, disconnect the connector (AB26) and (AB2). 2) Disconnect the connectors (AB27) and (AB4) of the passenger's airbag module. 3) Disconnect the connector (AB3) from airbag control module, and connect the connector (1R) in the test harness R. 4) Connect the battery ground terminal and turn the ignition switch to ON. 5) Connect two connectors, (5R) and (6R) in the test harness R. NOTE: After the problem has been eliminated, disconnect connectors (5R) and (6R).	Does the airbag warning light go off?	Go to step 4.	Go to step 5.
4	CHECK GROUND CIRCUIT. 1) Turn ignition switch OFF, disconnect the battery ground cable, and wait more than 20 seconds. 2) Disconnect connector (AB3) from airbag control module. 3) Connect the connector (1R) in the test harness R to body harness connector (AB3). 4) Measure resistance between connector (2R) in the test harness R and chassis ground. Connector & terminal (2R) No. 10 — Chassis ground: (2R) No. 11 — Chassis ground:	Is the resistance less than 10 Ω ?	Replace the airbag control module. <Ref. to AB-18, Airbag Control Module.>	Repair the chassis ground circuit.
5	CHECK AIRBAG MAIN HARNESS AND BULKHEAD HARNESS. 1) Disconnect the connector (5R) and (6R). 2) Remove the combination meter. 3) Measure resistance between connector (i11) in the test harness R and connector (2R). Connector & terminal (2R) No. 7 — (i11) No. 8:	Is the resistance less than 10 Ω ?	Check the combination meter.	Go to step 6.
6	CHECK POOR CONTACT OF CONNECTORS (AB1) AND (B31). 1) Turn ignition switch OFF, disconnect the battery ground cable, and wait more than 20 seconds. 2) Confirm that firm contact is secured between connectors (AB1) and (B31).	Is there poor contact in connectors (AB1) and (B31)?	Repair the bulkhead harness or replace the airbag main harness along with the body harness.	Go to step 7.

Airbag Warning Light Failure

AIRBAG SYSTEM (DIAGNOSTICS)

	Step	Check	Yes	No
7	CHECK AIRBAG MAIN HARNESS. Check the airbag main harness for abnormalities.	Is anything unusual to airbag main harness?	Replace the airbag main harness along with the bulk-head harness.	Repair the bulk-head harness.

Airbag Warning Light Failure

AIRBAG SYSTEM (DIAGNOSTICS)

B: AIRBAG WARNING LIGHT REMAINS OFF

DETECTING CONDITION:

- Blown fuse No. 14 (in fuse box)
- Body harness is open.
- Airbag warning light failure
- Airbag main harness is faulty.
- Airbag control module is faulty.

CAUTION:

- Before diagnosing the airbag system, be sure to turn the ignition switch to OFF, disconnect the ground terminal from battery, and wait more than 20 seconds before starting to work.
- When inspecting the airbag main harness, disconnect the airbag module connectors of the driver's and passenger's seats for safety.

WIRING DIAGRAM:

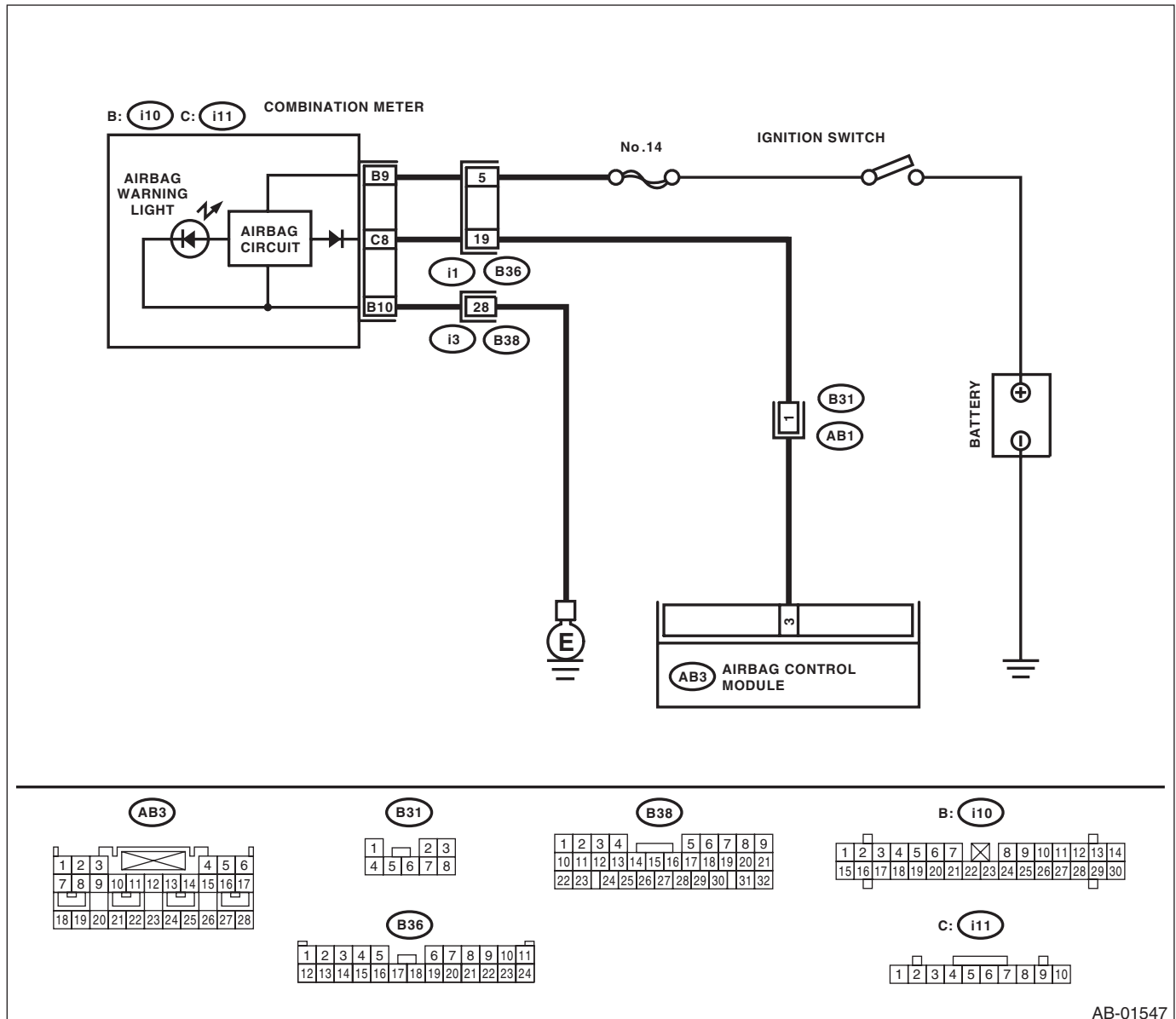

AB-01547

Airbag Warning Light Failure

AIRBAG SYSTEM (DIAGNOSTICS)

	Step	Check	Yes	No
1	CHECK COMBINATION METER. Turn the ignition switch to ON, and confirm that warning light embedded in the combination meter is turned on.	Do the warning lights except for the airbag turn on?	Go to step 2.	Check the combination meter. <Ref. to IDI-3, Combination Meter System.>
2	CHECK DTC. Read the DTC. <Ref. to AB(diag)-29, READ DIAGNOSTIC TROUBLE CODE (DTC), OPERATION, Subaru Select Monitor.>	Is DTC displayed?	Perform the diagnosis according to DTC.	Go to step 3.
3	CHECK FUSE NO. 14 (IN MAIN FUSE BOX). Remove the fuse No. 14 and perform visual inspection.	Is fuse No. 14 (in the main fuse box) blown out?	Replace the fuse No. 14. If fuse No. 14 is blown out again, go to step 4.	Go to step 4.
4	CHECK AIRBAG WARNING LIGHT CIRCUIT (IN COMBINATION METER). 1) Turn ignition switch OFF, disconnect the battery ground cable, and wait more than 20 seconds. 2) Disconnect the connector (AB1) from (B31). 3) Connect the battery ground terminal and turn the ignition switch to ON.	Does airbag warning light turn on?	Go to step 5.	Check the combination meter. <Ref. to IDI-10, Combination Meter.>
5	CHECK AIRBAG MAIN HARNESS. 1) Turn ignition switch OFF, disconnect the battery ground cable, and wait more than 20 seconds. 2) Connect the connector (AB1) to (B31). 3) Disconnect connector (AB3) from airbag control module. 4) Connect the battery ground terminal and turn the ignition switch to ON.	Does airbag warning light turn on?	Replace the airbag control module. <Ref. to AB-18, Airbag Control Module.>	Replace the airbag main harness along with the body harness.