

# Diagnostic Procedure with Diagnostic Trouble Code (DTC)

CRUISE CONTROL SYSTEM (DIAGNOSTICS)

## 8. Diagnostic Procedure with Diagnostic Trouble Code (DTC)

### A: DTC 11

DTC for cruise control command switch.

#### TROUBLE SYMPTOM:

- Cruise control cannot be set. (Cancelled immediately.)
- Cruise control cannot be released.

#### WIRING DIAGRAM:

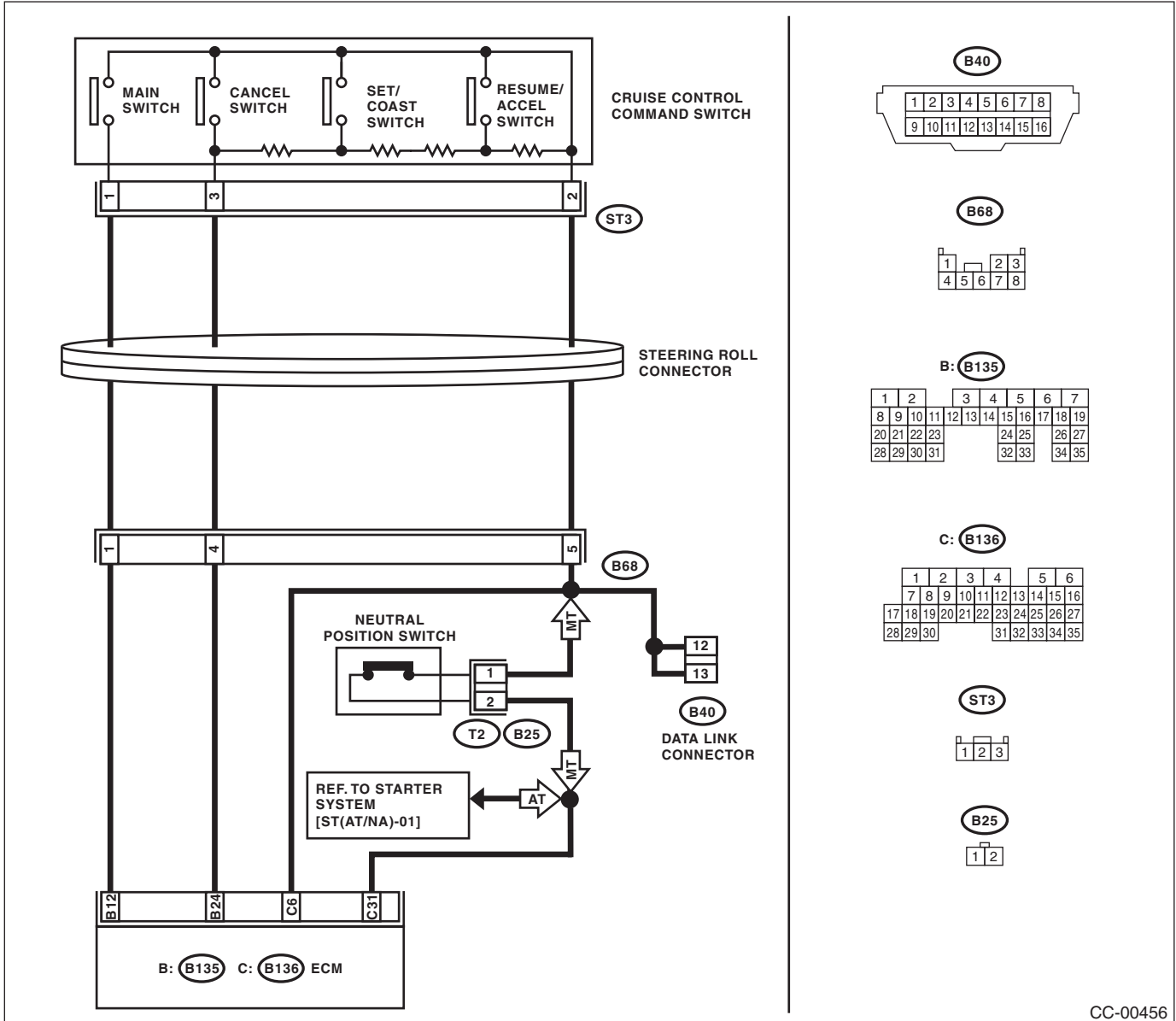

CC-00456

# Diagnostic Procedure with Diagnostic Trouble Code (DTC)

## CRUISE CONTROL SYSTEM (DIAGNOSTICS)

	Step	Check	Yes	No
1	<p><b>CHECK CRUISE CONTROL COMMAND SWITCH CIRCUIT.</b></p> <p>1) Remove the driver's airbag module. &lt;Ref. to AB-14, REMOVAL, Driver's Airbag Module.&gt;</p> <p>2) Disconnect the harness connector of cruise control command switch.</p> <p>3) Turn the ignition switch to ON.</p> <p>4) Measure the voltage between harness connector terminal and chassis ground.</p> <p><b>Connector &amp; terminal</b>  <b>(ST3) No. 1 (+) — Chassis ground (-):</b>  <b>(ST3) No. 3 (+) — Chassis ground (-):</b></p>	Is the voltage 5 V or more?	Go to step 2.	Check the harness between cruise control command switch and ECM for open or shorted circuit.
2	<p><b>CHECK CANCEL SWITCH.</b></p> <p>1) Turn the ignition switch to OFF.</p> <p>2) Remove the cruise control command switch. &lt;Ref. to CC-5, REMOVAL, Cruise Control Command Switch.&gt;</p> <p>3) Measure the resistance between switch terminals when the CANCEL switch is pressed and not pressed.</p> <p><b>Terminals</b>  <b>No. 2 — No. 3:</b></p>	Is the resistance approx. less than 1 $\Omega$ when the CANCEL switch is pressed? Is the resistance approx. 4 k $\Omega$ when the CANCEL switch is not pressed?	Go to step 3.	Replace the cruise control command switch. <Ref. to CC-5, Cruise Control Command Switch.>
3	<p><b>CHECK SET/COAST SWITCH.</b></p> <p>Measure the resistance between switch terminals when SET/COAST switch is pressed and not pressed.</p> <p><b>Terminals</b>  <b>No. 2 — No. 3:</b></p>	Is the resistance approx. 250 $\Omega$ when SET/COAST switch is pressed? Is the resistance approx. 4 k $\Omega$ when SET/COAST switch is not pressed?	Go to step 4.	Replace the cruise control command switch. <Ref. to CC-5, Cruise Control Command Switch.>
4	<p><b>CHECK RESUME/ACCEL SWITCH CIRCUIT.</b></p> <p>Measure the resistance between switch terminals when RESUME/ACCEL switch is pressed and not pressed.</p> <p><b>Terminals</b>  <b>No. 2 — No. 3:</b></p>	Is the resistance approx. 1,500 $\Omega$ when RESUME/ACCEL switch is pressed? Is the resistance approx. 4 k $\Omega$ when RESUME/ACCEL switch is not pressed?	Replace the ECM. <Ref. to FU(H4SO)-40, Engine Control Module (ECM).> <Ref. to FU(H4DOTC)-44, Engine Control Module (ECM).>	Replace the cruise control command switch. <Ref. to CC-5, Cruise Control Command Switch.>

# Diagnostic Procedure with Diagnostic Trouble Code (DTC)

## B: DTC 12

DTC for stop light switch and brake light switch.

### TROUBLE SYMPTOM:

- Cruise control cannot be set.
- Cruise control cannot be released.

### WIRING DIAGRAM:

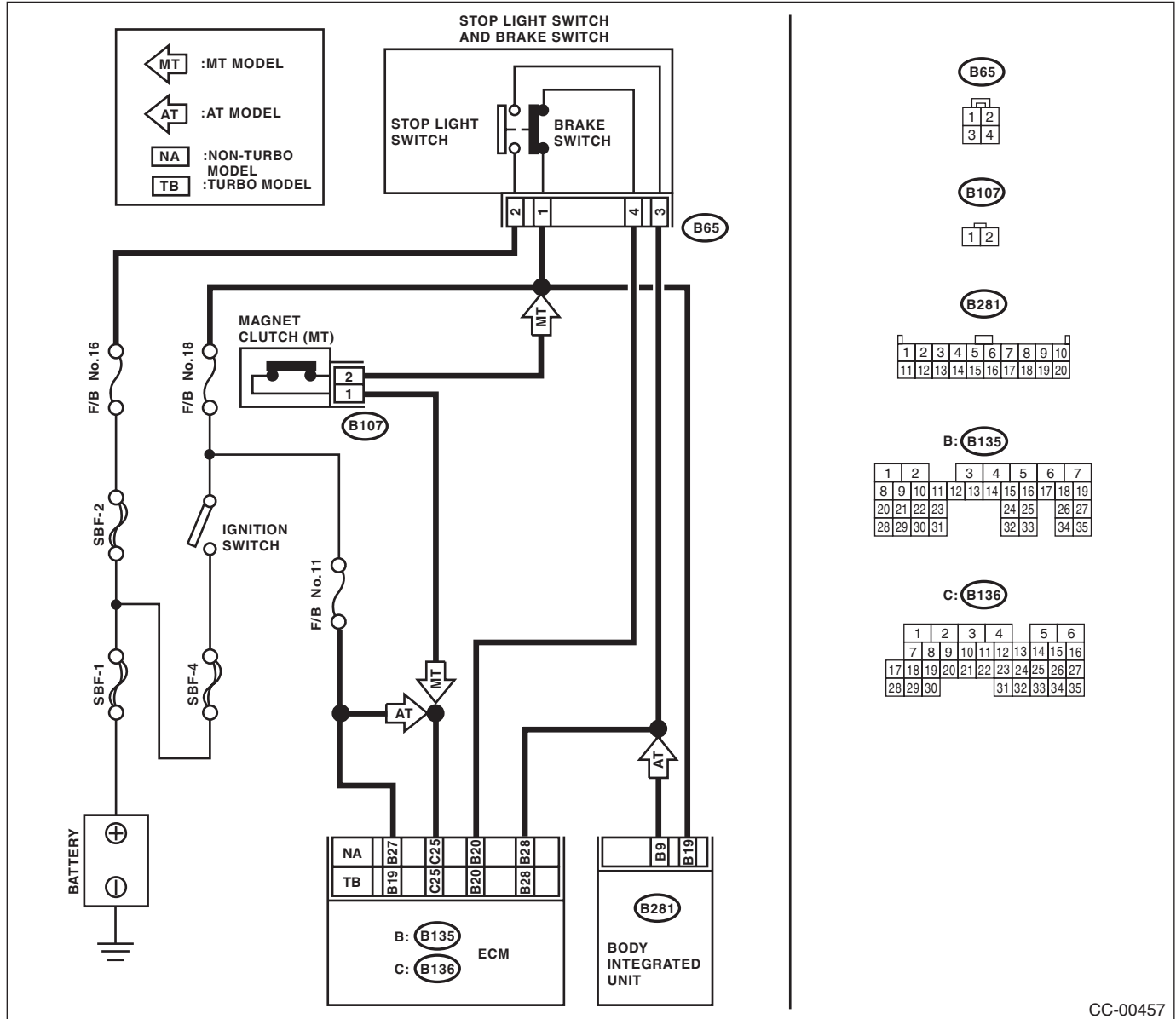

CC-00457

# Diagnostic Procedure with Diagnostic Trouble Code (DTC)

## CRUISE CONTROL SYSTEM (DIAGNOSTICS)

Step	Check	Yes	No
<b>1</b> <b>CHECK STOP LIGHT SWITCH AND BRAKE SWITCH CIRCUIT.</b> 1) Turn the ignition switch to OFF. 2) Disconnect the stop light switch and brake switch harness connector. 3) Turn the ignition switch to ON. 4) Measure the voltage between harness connector terminal and chassis ground. <i><b>Connector &amp; terminal</b></i> <i><b>(B65) No. 2 (+) — Chassis ground (-):</b></i>	Is the voltage 10 V or more?	Go to step 2.	<ul style="list-style-type: none"> <li>• Check fuse No. 16 (in fuse &amp; relay box).</li> <li>• Check for open or short in the harness between stop light/brake switch and fuse &amp; relay box.</li> </ul>
<b>2</b> <b>CHECK STOP LIGHT SWITCH AND BRAKE SWITCH CIRCUIT.</b> Measure the voltage between harness connector terminal and chassis ground. <i><b>Connector &amp; terminal</b></i> <i><b>(B65) No. 1 (+) — Chassis ground (-):</b></i>	Is the voltage 10 V or more?	Go to step 3.	<ul style="list-style-type: none"> <li>• Check fuse No. 18 (in fuse &amp; relay box).</li> <li>• Check for open or short in the harness between stop light/brake switch and fuse &amp; relay box.</li> <li>• Check the clutch switch and circuit.</li> </ul>
<b>3</b> <b>CHECK STOP LIGHT SWITCH AND BRAKE SWITCH CIRCUIT.</b> 1) Turn the ignition switch to OFF. 2) Disconnect the harness connector of ECM. 3) Disconnect the harness connector of body integrated unit. 4) Measure the resistance between harness connector terminals of ECM and of body integrated unit, and between harness connector terminals of stop light switch and of brake switch. <i><b>Connector &amp; terminal</b></i> <i><b>(B281) No. 9 — (B65) No. 3:</b></i> <i><b>(B135) No. 20 — (B65) No. 4:</b></i>	Is the resistance less than 10 $\Omega$ ?	Go to step 4.	Repair the harness.
<b>4</b> <b>CHECK STOP LIGHT SWITCH AND BRAKE SWITCH.</b> Remove and check the stop light switch and brake switch. <Ref. to CC-6, Stop Light & Brake Switch.>	Are the stop light switch and brake switch OK?	Stop light switch and brake switch circuit are OK.	Replace the stop light switch and brake switch.

# Diagnostic Procedure with Diagnostic Trouble Code (DTC)

## C: DTC 13

DTC for clutch switch.

### TROUBLE SYMPTOM:

- Cruise control cannot be set.
- Cruise control cannot be released.

### WIRING DIAGRAM:

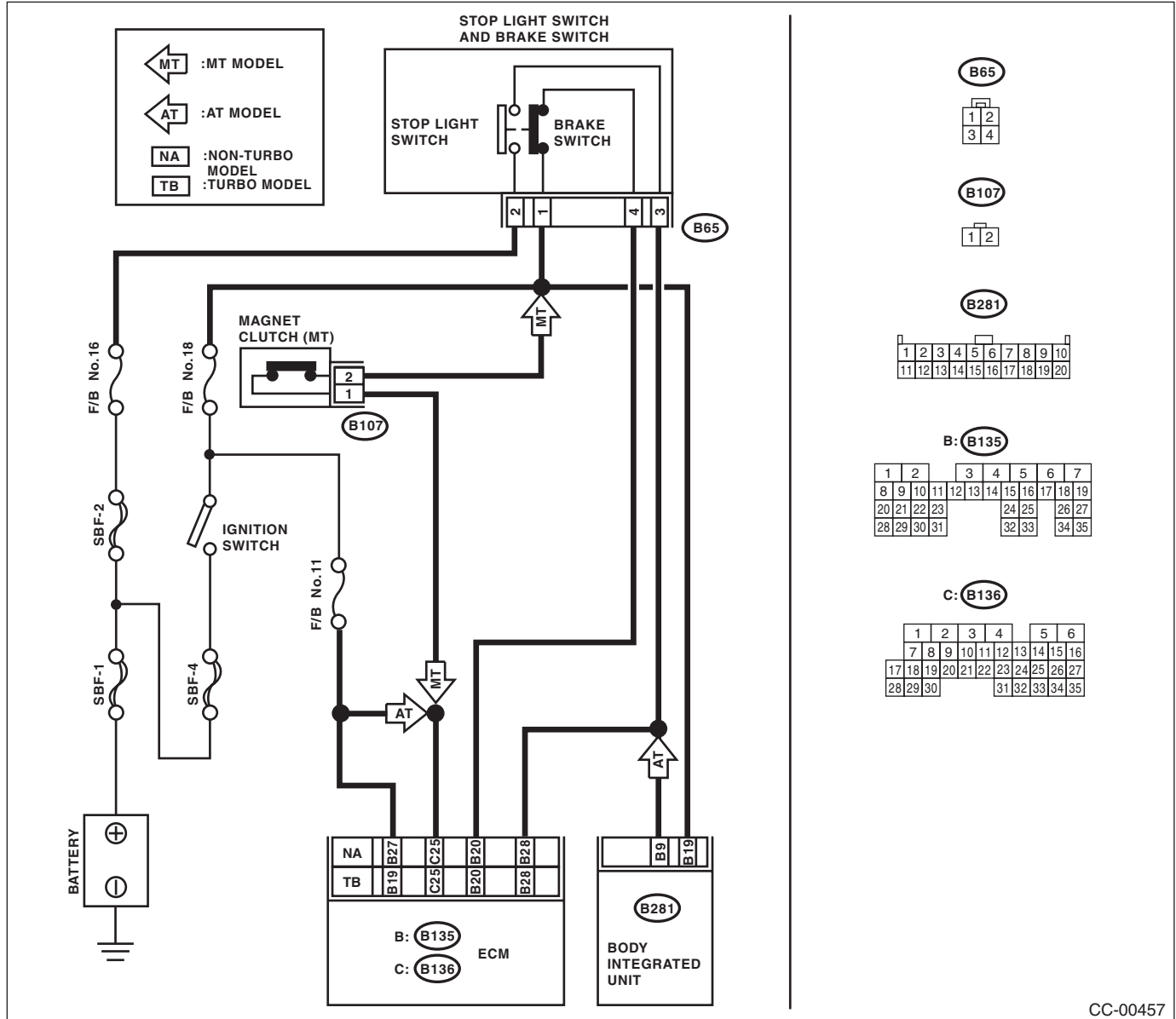

CC-00457

# Diagnostic Procedure with Diagnostic Trouble Code (DTC)

## CRUISE CONTROL SYSTEM (DIAGNOSTICS)

	Step	Check	Yes	No
1	<b>CHECK CLUTCH SWITCH CIRCUIT.</b> 1) Turn the ignition switch to OFF. 2) Disconnect the clutch switch harness connector. 3) Turn the ignition switch to ON. 4) Measure the voltage between harness connector terminal and chassis ground. <b>Connector &amp; terminal</b> <b>(B107) No. 2 (+) — Chassis ground (-):</b>	Is the voltage 10 V or more?	Go to step 2.	<ul style="list-style-type: none"> <li>• Check fuse No. 18 (in fuse &amp; relay box).</li> <li>• Check open or shorted circuit of harness between clutch switch and fuse &amp; relay box.</li> </ul>
2	<b>CHECK CLUTCH SWITCH CIRCUIT.</b> 1) Turn the ignition switch to OFF. 2) Disconnect the harness connector of ECM. 3) Measure the resistance between clutch switch harness connector terminal and ECM harness connector terminal. <b>Connector &amp; terminal</b> <b>(B107) No. 1 — (B136) No. 25:</b>	Is the resistance less than 10 $\Omega$ ?	Go to step 3.	Repair the harness.
3	<b>CHECK CLUTCH SWITCH.</b> Remove and check the clutch switch. <Ref. to CC-7, Clutch Switch.>	Is clutch switch OK?	Clutch switch circuit is OK.	Replace the clutch switch.

# Diagnostic Procedure with Diagnostic Trouble Code (DTC)

CRUISE CONTROL SYSTEM (DIAGNOSTICS)

## D: DTC 14

DTC for neutral position switch.

### TROUBLE SYMPTOM:

Cruise control cannot be set.

### WIRING DIAGRAM:

- Turbo model

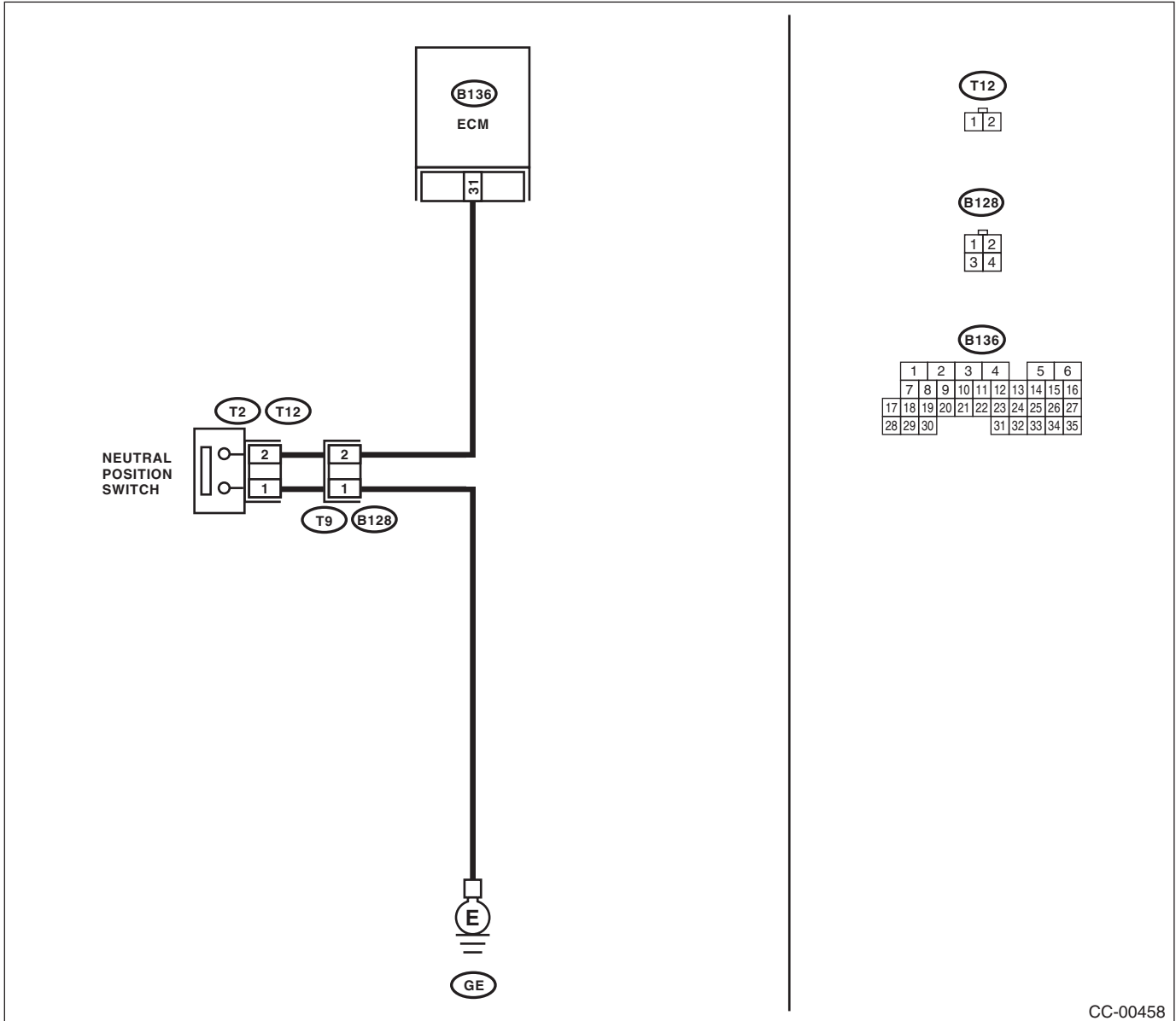

CC-00458

# Diagnostic Procedure with Diagnostic Trouble Code (DTC)

## CRUISE CONTROL SYSTEM (DIAGNOSTICS)

- Non-turbo model

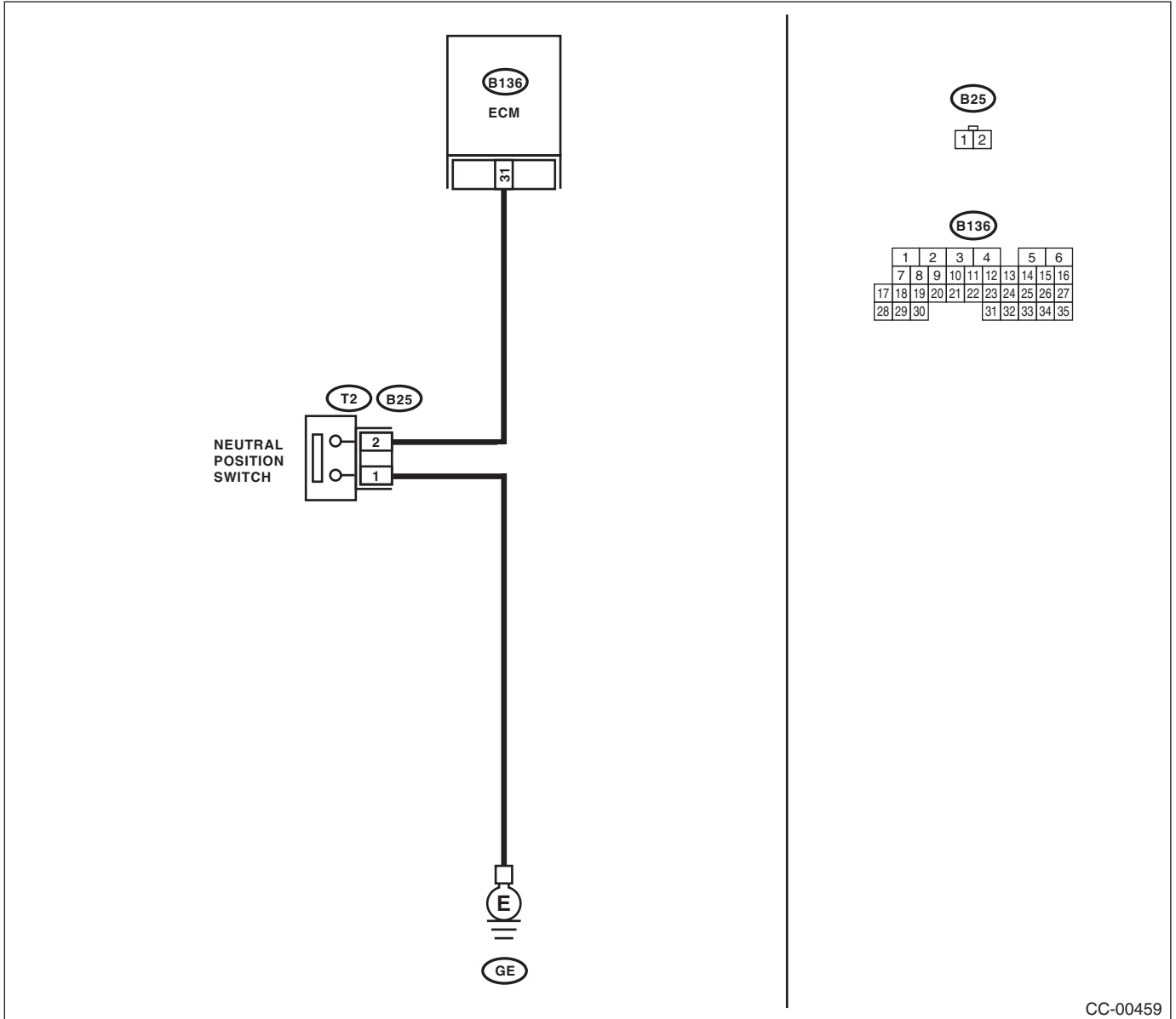

CC-00459



# Diagnostic Procedure with Diagnostic Trouble Code (DTC)

CRUISE CONTROL SYSTEM (DIAGNOSTICS)

Step	Check	Yes	No
<b>1 CHECK NEUTRAL POSITION SWITCH CIRCUIT.</b> 1) Turn the ignition switch to OFF. 2) Disconnect the neutral position switch harness connector. 3) Turn the ignition switch to ON. 4) Measure the voltage between harness connector terminal and chassis ground. <b>Connector &amp; terminal</b> <b>Turbo model</b> <b>(B128) No. 1 (+) — Chassis ground (-):</b> <b>Non-turbo model</b> <b>(B25) No. 2 (+) — Chassis ground (-):</b>	Is the voltage 10 V or more?	Go to step 2.	Check for open or short in the harness between neutral position switch and ECM.
<b>2 CHECK NEUTRAL POSITION SWITCH CIRCUIT.</b> 1) Turn the ignition switch to OFF. 2) Measure resistance between harness connector terminal of neutral position switch and chassis ground. <b>Connector &amp; terminal</b> <b>Turbo model</b> <b>(B128) No. 3 — Chassis ground:</b> <b>Non-turbo model</b> <b>(B25) No. 3 — Chassis ground:</b>	Is the resistance less than 10 $\Omega$ ?	Go to step 3.	Repair the harness.
<b>3 CHECK NEUTRAL POSITION SWITCH.</b> Remove and check the neutral position switch.	Is the neutral position switch OK?	The neutral position switch circuit is working properly.	Replace the neutral position switch.

## E: DTC 15

Malfunction of cancel switch is detected.

Refer to DTC 11 for diagnostic procedure.

<Ref. to CC(ETC)(diag)-15, DTC 11, Diagnostic Procedure with Diagnostic Trouble Code (DTC).>

# Diagnostic Procedure with Diagnostic Trouble Code (DTC)

## CRUISE CONTROL SYSTEM (DIAGNOSTICS)

### F: DTC 16

DTC for ignition switch.

#### TROUBLE SYMPTOM:

Cruise control cannot be set.

#### WIRING DIAGRAM:

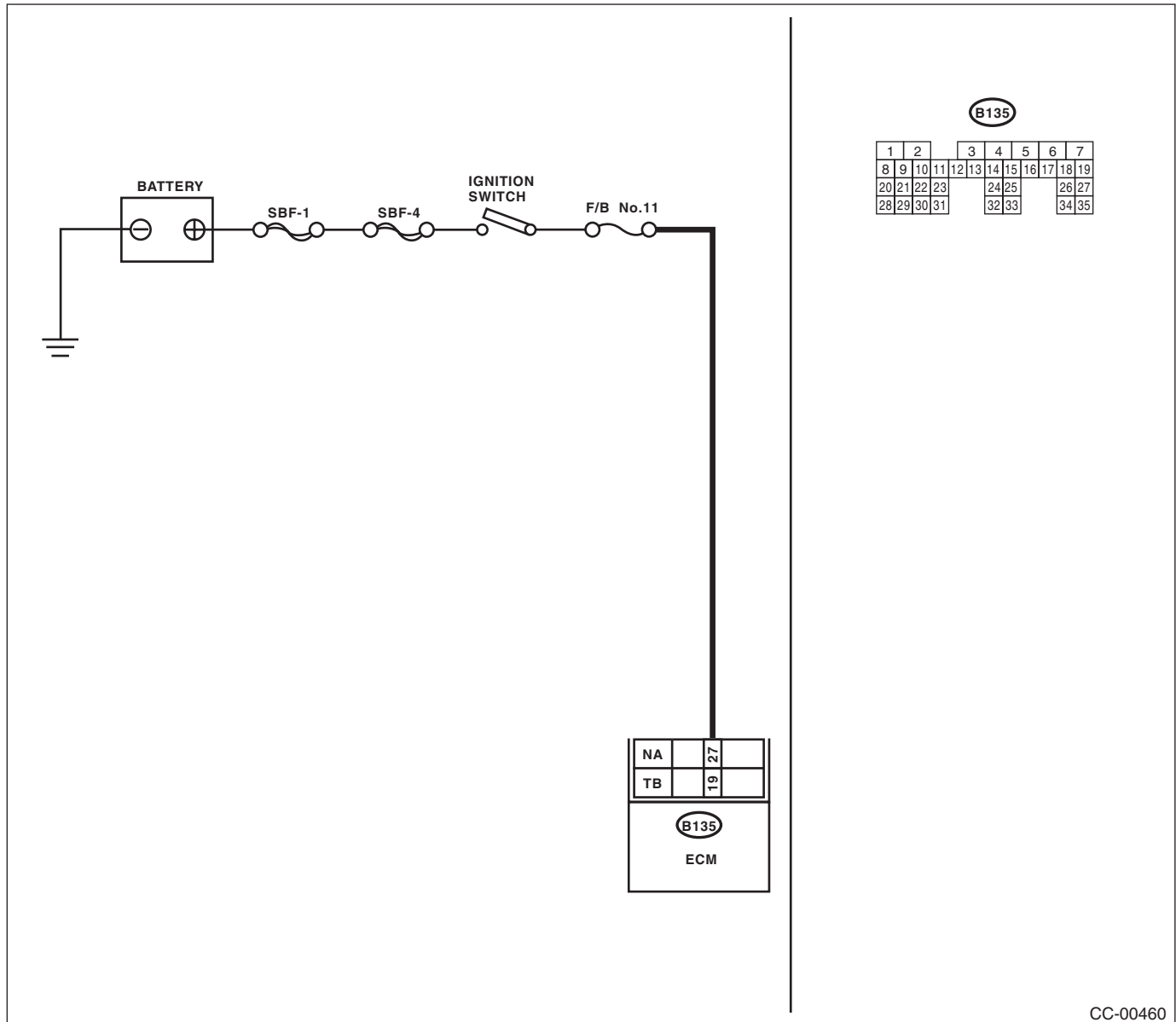

CC-00460

Step	Check	Yes	No
<b>1</b> <b>CHECK IGNITION SWITCH CIRCUIT.</b> 1) Turn the ignition switch to OFF. 2) Disconnect the ECM harness connector. 3) Turn the ignition switch to ON. 4) Measure the voltage between harness connector terminal and chassis ground. <b>Connector &amp; terminal</b> <b>Turbo model</b> (B135) No. 19 (+) — Chassis ground (-): <b>Non-turbo model</b> (B135) No. 27 (+) — Chassis ground (-):	Is the voltage 10 V or more?	Check the poor contact of ECM connector.	<ul style="list-style-type: none"> <li>• Check fuse No. 11 (in fuse &amp; relay box).</li> <li>• Check the harness for open or short circuit between ignition switch and ECM.</li> </ul>

# Diagnostic Procedure with Diagnostic Trouble Code (DTC)

CRUISE CONTROL SYSTEM (DIAGNOSTICS)

## G: DTC 21

Cruise control command switch malfunction is detected.

Refer to DTC 11 for diagnostic procedure.

<Ref. to CC(ETC)(diag)-15, DTC 11, Diagnostic Procedure with Diagnostic Trouble Code (DTC).>

## H: DTC 22

### DTC DETECTING CONDITION:

Open or shorted circuit in vehicle speed sensor system.

### TROUBLE SYMPTOM:

Cruise control cannot be set. (Cancelled immediately.)

### WIRING DIAGRAM:

Step	Check	Yes	No
<b>1</b> <b>CHECK ABS WARNING LIGHT.</b> 1) Turn the ignition switch to ON. 2) After the initial operation of combination meter is completed, check if the ABS warning light continues to illuminate.	Does the ABS warning continues to illuminate?	Check the ABSCM. <Ref. to ABS(diag)-2, PROCEDURE, Basic Diagnostic Procedure.>	Go to step 2.
<b>2</b> <b>CHECK VEHICLE SPEED SENSOR SIGNAL.</b> 1) Connect the Subaru Select Monitor to the data link connector. 2) Turn the ignition switch and Subaru Select Monitor switch to ON. 3) Select {Engine} from the main menu. 4) Then select {Current Data Display & Save}. 5) Drive the vehicle and check the vehicle speed sensor signal.	Is the vehicle speed displayed on the Subaru Select Monitor?	Replace the ECM. <Ref. to FU(H4DOTC)-44, REMOVAL, Engine Control Module (ECM).>	Replace the vehicle speed sensor.

## I: DTC 24

Malfunction of cruise control related switch is detected.

Refer to DTC 11 for diagnostic procedure.

<Ref. to CC(ETC)(diag)-15, DTC 11, Diagnostic Procedure with Diagnostic Trouble Code (DTC).>

## J: DTC 25

Malfunction of brake switch input circuit is detected.

Refer to engine diagnostic procedure for diagnostic procedure.

<Ref. to EN(H4SO)(diag)-2, PROCEDURE, Basic Diagnostic Procedure.>

<Ref. to EN(H4DOTC)(diag)-2, PROCEDURE, Basic Diagnostic Procedure.>

## K: DTC 31

Malfunction of engine speed signal is detected.

Abnormal increase of engine speed is detected.

Gear is placed in 1st or Reverse position.

Set cruise again while driving in 2nd or higher gear. If a DTC is not detected, it is operating normally.

## L: DTC 32

Out of system vehicle speed range detected.

Refer to DTC 22 for diagnostic procedure.

<Ref. to CC(ETC)(diag)-25, DTC 22, Diagnostic Procedure with Diagnostic Trouble Code (DTC).>

## M: DTC 34

Malfunction of acceleration opening duration is detected.

The vehicle has been driven at higher speed than set vehicle speed for a long time (approximately 10 minutes) during cruise driving.

DTC is detected when driving for a long period of time at higher speed than the cruise set vehicle speed by operating the accelerator pedal.

Cancel the cruise setting. If the DTC is not detected again, it is normal.

# Diagnostic Procedure with Diagnostic Trouble Code (DTC)

## CRUISE CONTROL SYSTEM (DIAGNOSTICS)

---

### **N: DTC 35**

Malfunction of acceleration opening duration is detected.

The vehicle has been driven at higher speed than set vehicle speed for a long time (approximately 10 minutes) during cruise driving.

DTC is detected when driving for a long period of time at higher speed than the cruise set vehicle speed by operating the accelerator pedal.

Cancel the cruise setting. If the DTC is not detected again, it is normal.

### **O: DTC 43**

ABS/VDC malfunction is detected.

ABS malfunction is detected during cruise or during cruise setting.

Refer to ABS diagnostic procedure for diagnostic procedure.

<Ref. to ABS(diag)-2, PROCEDURE, Basic Diagnostic Procedure.>

### **P: DTC 61**

Brake light switch malfunction is detected.

Refer to DTC 12 for diagnostic procedure.

<Ref. to CC(ETC)(diag)-17, DTC 12, Diagnostic Procedure with Diagnostic Trouble Code (DTC).>

### **Q: DTC 62**

Neutral position switch malfunction is detected.

Refer to DTC 14 for diagnostic procedure.

<Ref. to CC(ETC)(diag)-21, DTC 14, Diagnostic Procedure with Diagnostic Trouble Code (DTC).>

### **R: DTC 63**

Malfunction of vehicle speed signal variation is detected.

Refer to DTC 22 for diagnostic procedure.

<Ref. to CC(ETC)(diag)-25, DTC 22, Diagnostic Procedure with Diagnostic Trouble Code (DTC).>

### **S: DTC 64**

Malfunction related to the engine is detected.

Refer to engine diagnostic procedure for diagnostic procedure.

<Ref. to EN(H4SO)(diag)-2, PROCEDURE, Basic Diagnostic Procedure.>

<Ref. to EN(H4DOTC)(diag)-2, PROCEDURE, Basic Diagnostic Procedure.>

### **T: DTC 65**

Cruise control command switch malfunction is detected.

While the command switch is pressed ON for a long time (approximately two minutes), an ON stuck open circuit is detected.

Refer to DTC 11 for diagnostic procedure.

<Ref. to CC(ETC)(diag)-15, DTC 11, Diagnostic Procedure with Diagnostic Trouble Code (DTC).>

### **U: DTC 66**

Cruise control computational malfunction is detected.

Refer to engine diagnostic procedure for diagnostic procedure.

<Ref. to EN(H4SO)(diag)-2, PROCEDURE, Basic Diagnostic Procedure.>

<Ref. to EN(H4DOTC)(diag)-2, PROCEDURE, Basic Diagnostic Procedure.>